

z/VM

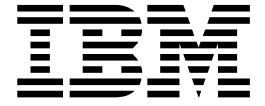

# I/O Configuration

*Version 6 Release 3*

**Note:**

Before you use this information and the product it supports, read the information in "Notices" on page 373.

This edition applies to version 6, release 3, modification 0 of IBM z/VM (product number 5741-A07) and to all subsequent releases and modifications until otherwise indicated in new editions.

This edition replaces SC24-6198-04.

© **Copyright IBM Corporation 1991, 2016.**

US Government Users Restricted Rights – Use, duplication or disclosure restricted by GSA ADP Schedule Contract with IBM Corp.

---

# Contents

<b>Figures</b> . . . . .	<b>xi</b>
<b>Tables</b> . . . . .	<b>xiii</b>
<b>About This Document</b> . . . . .	<b>xv</b>
Intended Audience . . . . .	xv
Where to Find More Information . . . . .	xv
Links to Other Documents and Websites . . . . .	xv
<b>How to Send Your Comments to IBM</b> . . . . .	<b>xvii</b>
<b>Summary of Changes</b> . . . . .	<b>xix</b>
SC24-6198-05, z/VM Version 6 Release 3 (February 2016) . . . . .	xix
IBM z13 (Driver D27) and z13s Compatibility I/O Support . . . . .	xix
SC24-6198-04, z/VM Version 6 Release 3 (May 2015) . . . . .	xx
z13 Compatibility I/O Support . . . . .	xx
SC24-6198-03, z/VM Version 6 Release 3 . . . . .	xx
PCIe Guest Direct Attach Support . . . . .	xx
New HCD Reports . . . . .	xx
Hardware Support . . . . .	xxi
SC24-6198-02, z/VM Version 6 Release 2 . . . . .	xxi
Enhancement of the CSS/OS Device Compare Report . . . . .	xxi
New Classification for Severe Warning Messages . . . . .	xxi
New REXX Utility to Support Configuration Packages . . . . .	xxi
New Profile Options . . . . .	xxi
Changes in HCD Reports . . . . .	xxii
Support of the WWWPN Prediction Tool . . . . .	xxii
Hardware Support . . . . .	xxii
SC24-6198-01, z/VM Version 6 Release 1 (Updated Edition) . . . . .	xxii
Support for OSX and OSM Channel Path Identifiers . . . . .	xxii
SC24-6198-00, z/VM Version 6 Release 1 . . . . .	xxiii
Architecture Level Set to System z10 . . . . .	xxiii

---

## **Part 1. Introduction** . . . . . **1**

### **Chapter 1. Overview** . . . . . **3**

What are HCM and HCD? . . . . .	3
What is Dynamic I/O Configuration? . . . . .	3
Choosing One Way to Work . . . . .	4
One-Time Disablement of HCM and HCD . . . . .	4

---

## **Part 2. Using HCM and HCD** . . . . . **5**

### **Chapter 2. Introduction to HCM and HCD** . . . . . **7**

Components and Terminology . . . . .	8
--------------------------------------	---

### **Chapter 3. Hardware Configuration Definition - What Is It?** . . . . . **9**

What HCD Is and How It Differs from IOCP and VM Configuration Definition . . . . .	9
Definition of Configuration Data . . . . .	9
Validation of Configuration Data . . . . .	11
Reconfiguration of Configuration Data . . . . .	11
What HCD Offers You . . . . .	12
How HCD Works . . . . .	13

Objects Managed in the IODF . . . . .	14
IODF Used at IPL . . . . .	15
Relationship of Files Used by HCD . . . . .	15
The Environment in which z/VM HCD Operates. . . . .	16
z/VM HCD and the Coupling Facility . . . . .	17
<b>Chapter 4. I/O Configuration Definition Process . . . . .</b>	<b>19</b>
Defining an I/O Configuration to the Software . . . . .	19
IODF . . . . .	19
UIMs . . . . .	20
RDEV . . . . .	20
Defining an I/O Configuration to the Hardware . . . . .	20
IOCP . . . . .	21
IOCDS (Input/Output Configuration Data Set) . . . . .	21
HSA . . . . .	21
Ensuring that the Software and Hardware Definitions Match . . . . .	21
<b>Chapter 5. How to Set Up and Customize z/VM HCD . . . . .</b>	<b>25</b>
Setting Up z/VM HCD . . . . .	25
Setting Up the z/VM HCD TCP/IP Dispatcher for HCM . . . . .	25
Defining an HCD Profile . . . . .	26
Keywords . . . . .	26
<b>Chapter 6. How to Work with I/O Definition Files . . . . .</b>	<b>31</b>
IODF and Activity Log Naming Conventions . . . . .	31
Deciding on the Number of IODFs . . . . .	32
The Master IODF Concept . . . . .	33
Maintain IODFs . . . . .	34
Create and Initialize an IODF . . . . .	35
Delete an IODF . . . . .	35
Copy an IODF . . . . .	35
Build Production IODF . . . . .	35
Activate a Configuration . . . . .	36
Build a Work IODF from a Production IODF . . . . .	36
Compare IODFs or CSS/OS Configurations . . . . .	36
View a Configuration . . . . .	36
Export an IODF . . . . .	36
Import an IODF . . . . .	37
Print and Draw Configuration Reports . . . . .	37
Activity Logging . . . . .	37
Rules for Activity Logging . . . . .	37
Actions Performed on IODFs and Related Activity and Change Log Files. . . . .	38
The New IODF Version 5 Format . . . . .	38
Coexistence Overview of Functionality Based on IODF Version . . . . .	39
<b>Chapter 7. How to Work with Switches . . . . .</b>	<b>41</b>
Possibilities of Switch Connections . . . . .	41
Advantages of Switch Definitions with HCD . . . . .	44
<b>Chapter 8. How to Activate or Process Configuration Data . . . . .</b>	<b>45</b>
Build a Production IODF . . . . .	45
Build an IOCDS or IOCP Input File . . . . .	46
Build an IOCP Input File . . . . .	46
Using the IOCP File as Input for the CHPID Mapping Tool . . . . .	48
How to interact with the CHPID Mapping Tool . . . . .	49
Process overview . . . . .	49
How to insert or update PCHIDs . . . . .	49
Specify a Production IODF for IPL . . . . .	50
Activate a Configuration Dynamically . . . . .	52
Actions to Change Your Configuration Dynamically . . . . .	52

Making Both Hardware and Software Dynamic Changes . . . . .	54
Making Software-Only Dynamic Changes . . . . .	54
Dynamically Changing an I/O Configuration . . . . .	55
Dynamically Changing Components in an I/O Configuration . . . . .	55
Testing Dynamic Activation . . . . .	64
Recovery during Dynamic Configuration . . . . .	64
Detection of Illegal Split/Merge of LCU . . . . .	66
<b>Chapter 9. How to Print and Compare Configuration Data. . . . .</b>	<b>69</b>
Print Configuration Reports . . . . .	69
Channel Subsystem Report . . . . .	69
Switch Report . . . . .	70
Operating System Report . . . . .	70
CTC Connection Report . . . . .	70
Supported Hardware Report . . . . .	71
I/O Definition Reference . . . . .	71
Create Graphical Configuration Reports . . . . .	71
Prerequisites . . . . .	71
Printing the Output . . . . .	72
Compare Functions . . . . .	72
Compare IODFs . . . . .	72
Compare CSS / Operating System Views . . . . .	73
View the HCD Activity Log . . . . .	73
<b>Chapter 10. How to Migrate your Environment to z/VM HCD. . . . .</b>	<b>75</b>
Migration from an IOCP . . . . .	75
Migrating the OS Configuration . . . . .	78
<b>Chapter 11. How to Migrate Existing Input Files . . . . .</b>	<b>79</b>
Migration Sequence . . . . .	80
Preparing Your Input Files for Migration . . . . .	80
Data Requiring Attention . . . . .	80
Preparing Additional Input Files for Migration . . . . .	82
Migrating Input Files Using a REXX Utility . . . . .	86
Step 1: Create the Work IODF . . . . .	86
Step 2: Migrate Input File . . . . .	86
Step 3: Analyze Errors and Upgrade the Input File . . . . .	87
Step 4: Build Production IODF . . . . .	87
Changing I/O Configurations by Editing Files . . . . .	87
Build I/O Configuration Statements . . . . .	88
Additional Parameters and Statements . . . . .	88
Device for VM Definitions . . . . .	105
Updating Parts of a Configuration by Migrating Input Files . . . . .	106
Possible Actions on Objects Using the Incremental Update . . . . .	107
How to Invoke the Incremental Update . . . . .	110
Resolving Migration Errors . . . . .	115
Errors Detected During Assembly Process . . . . .	115
Errors Detected During Validation Process . . . . .	116
<b>Chapter 12. How to Invoke the HCD Functions . . . . .</b>	<b>119</b>
Methods to Invoke HCD Functions . . . . .	119
Input Parameter String . . . . .	120
What is Common to all REXX Utilities . . . . .	120
List of Available HCD Functions . . . . .	121
Programming Information for HCD Functions . . . . .	122
Create and Initialize an IODF (CBDSIODF) . . . . .	123
Migrate I/O Configuration Statements (CBDSMIGR) . . . . .	126
Build a Production IODF (CBDSPROD) . . . . .	133
Build a Work IODF from a Production IODF (CBDSWORK) . . . . .	135
Build an IOCDs or an IOCP Input File (CBDSIOCP) . . . . .	137

Build I/O Configuration Data (CBDSCONF) . . . . .	140
Copy IODF (CBDSCOPY) . . . . .	143
Print Configuration Reports (CBDSREP) . . . . .	145
Create a Graphical Configuration Report (CBDSDRAW) . . . . .	148
IODFs or CSS/OS Compare Reports (CBDSCOMP). . . . .	151
Import an IODF (CBDSIMP) . . . . .	158
Export an IODF (CBDSEXP) . . . . .	160
Activate a Configuration (CBDSACT) . . . . .	163
Manage Configuration Packages (CBSDPKG) . . . . .	168
Generate I/O Configuration File from Control Blocks (CBDSRDEV) . . . . .	170
List of Standard DD Names . . . . .	172
List of Alternate DD Names . . . . .	173

## **Chapter 13. Configuration Reports . . . . . 175**

Textual Configuration Reports . . . . .	175
Channel Subsystem Reports . . . . .	175
Switch Reports . . . . .	193
Operating System Reports . . . . .	195
CTC Connection Report . . . . .	197
Supported Hardware Report . . . . .	199
I/O Definition Reference . . . . .	221
Graphical Configuration Reports . . . . .	222
LCU Report . . . . .	222
IODF Compare Reports . . . . .	223
Processor Compare Report . . . . .	223
Channel Subsystem Compare Report . . . . .	224
PCIe Function Compare Report . . . . .	225
Partition Compare Report . . . . .	226
Channel Path Compare Report . . . . .	227
Control Unit Attachment Compare Report. . . . .	228
Device Attachment Compare Report. . . . .	229
Control Unit Compare Report . . . . .	229
Device Compare Report . . . . .	230
Switch Compare Report . . . . .	231
Switch Detail Compare Report . . . . .	232
Switch Configuration Detail Compare Report. . . . .	233
OS Device Compare Report . . . . .	234
OS Console Compare Report . . . . .	234
CSS / Operating System Device Compare . . . . .	235

## **Chapter 14. Problem Determination . . . . . 237**

Identifying Problems . . . . .	237
HCD Abnormal Termination . . . . .	238
Error During IODF Statement Processing . . . . .	240
Problems with Help Information Provided by HCD . . . . .	240
Problems with Output of HCD Textual Reports . . . . .	241
Problems with Output of HCD Graphical Reports . . . . .	241
Problems During Initialization of HCD . . . . .	243
Problems with UIMs . . . . .	244
HCD Internal Problems . . . . .	245
Diagnostic Information and Tools. . . . .	245
HCD Messages . . . . .	245
HCD Trace Facility . . . . .	246
Searching Problem Reporting Data Bases and Reporting Problems. . . . .	253

## **Chapter 15. Migration Scenarios to z/VM HCD for z/VM and z/OS . . . . . 255**

Scenario 1: How to Migrate to HCD in a z/VM Environment Without z/OS . . . . .	255
Step 1. Prepare the IOCP deck for HCD . . . . .	256
Step 2. Create and Initialize an Empty Work IODF . . . . .	258
Step 3. Migrate the z/VM IOCP into the Work IODF . . . . .	259

Step 4. Migrate Your Operating System from an RDEV List . . . . .	261
Step 5. Check Your Configuration Specification . . . . .	261
Step 6. Build the Production IODF . . . . .	262
Step 7. Build the IOCDS. . . . .	263
Step 8. Set Up the SYSTEM CONFIG File . . . . .	263
Step 9. Perform a Power on Reset (POR) . . . . .	264
Step 10. Perform an Initial Program Load (IPL) . . . . .	265
Step 11. Load the Configuration into HCM . . . . .	268
Post-Migration Configuration Management with HCD . . . . .	268
Scenario 2: How to Migrate in a Mixed z/VM and z/OS Environment . . . . .	269
Step 1. Migrate the z/VM IOCP into the Work IODF . . . . .	270
Step 2. Check your Configuration Specification . . . . .	271
Step 3. Integrate your Operating System(s) into the IODF . . . . .	271
Step 4. Build the Production IODF . . . . .	271
Step 5. Build the IOCDS. . . . .	271
Step 6. Set Up the SYSTEM CONFIG File . . . . .	272
Step 7. POR and IPL . . . . .	272
Post-Migration Configuration Management with HCD . . . . .	272
How to Exchange IODF or IOCP Files Between z/VM and z/OS . . . . .	273

---

## **Part 3. Using Dynamic I/O Configuration . . . . . 275**

### **Chapter 16. Introduction to the Dynamic I/O Configuration Facility . . . . . 277**

What is an I/O Configuration? . . . . .	277
What Is Dynamic I/O Configuration? . . . . .	277
Where Is the I/O Configuration Information Stored? . . . . .	278
The Hardware View . . . . .	278
The Software View . . . . .	278
What Can I Do with Dynamic I/O Configuration? . . . . .	278
What to Expect from These Chapters . . . . .	279

### **Chapter 17. Understanding Hardware Configuration. . . . . 281**

Understanding LPAR Mode . . . . .	281
How Does the Hardware Get Its View of the I/O Configuration? . . . . .	282
Defining the Hardware I/O Configuration . . . . .	282
Writing the Hardware I/O Configuration to Disk . . . . .	283
Bringing the Hardware I/O Configuration Online . . . . .	283
Creating the z/VM I/O Configuration . . . . .	283

### **Chapter 18. Understanding Dynamic Configuration in z/VM . . . . . 285**

Hardware Functions . . . . .	285
Channel Path Definitions . . . . .	285
Control Unit Definitions. . . . .	285
I/O Device Definitions . . . . .	286
Logical Partition Definitions . . . . .	286
Switching the Active IOCDS File . . . . .	287
Software Functions . . . . .	287
Channel Path Definitions . . . . .	287
Control Unit Definitions. . . . .	288
I/O Device Definitions . . . . .	289
Logical Partition Definitions . . . . .	290
Switching the Active IOCDS File . . . . .	290

### **Chapter 19. Migrating to Dynamic I/O Configuration. . . . . 291**

Dynamic I/O Terminology . . . . .	291
Preparing to Dynamically Change Your I/O Configuration . . . . .	292
Enabling Dynamic I/O in the Hardware . . . . .	292
Enabling Dynamic I/O in the Software. . . . .	294
How to Run a System: Two Philosophies . . . . .	296

The Plug 'n' Play Philosophy . . . . .	296
The Lock-Step Philosophy . . . . .	296
<b>Chapter 20. Planning an I/O Configuration . . . . .</b>	<b>299</b>
How S/390 Processors Communicate with Their I/O Devices . . . . .	299
Building an I/O Configuration . . . . .	299
Changing and Rebuilding the I/O Configuration . . . . .	300
The Lock-Step Philosophy . . . . .	300
Building an IOCP Source File . . . . .	302
Understanding LPAR Mode . . . . .	303
Building an IOCP Source File . . . . .	303
Adding to IOCP Source Files without Using Dynamic I/O . . . . .	304
<b>Chapter 21. Understanding Dynamic I/O Configuration and LPARs . . . . .</b>	<b>307</b>
Planning for Dynamic I/O Changes . . . . .	307
Choose One Logical Partition for Dynamic I/O . . . . .	307
The Lock-Step Philosophy . . . . .	309
Prevent All Other Logical Partitions from Using Dynamic I/O . . . . .	310
Dynamic I/O Considerations for LPARs . . . . .	310
<b>Chapter 22. Using VM Dynamic I/O Configuration . . . . .</b>	<b>313</b>
The Dynamic I/O Process . . . . .	313
The Lock-Step Philosophy . . . . .	313
Understanding Configuration Mode . . . . .	314
Controlling Configuration Mode . . . . .	315
Checking Configuration Mode Status . . . . .	315
When Configuration Mode Is Interrupted . . . . .	316
Example 1: Adding a String of 3390 DASDs and a 3990 Controller. . . . .	317
Example 2: Adding a String of Shared 3490 Tape Drives to Two Logical Partitions . . . . .	319
Example 3: Replacing a String of 3380 DASDs with RAMAC DASD . . . . .	321
Example 4: An Alternate Way . . . . .	323
<b>Chapter 23. Understanding Potential Problem Areas . . . . .</b>	<b>325</b>
z/VM and z/OS Do Not Mix . . . . .	325
But a Little Mixing Can Help to Manage z/VM and z/OS Guests . . . . .	325
Monopoly Is the Name of the Game. . . . .	326
Play It Safe . . . . .	326
The Lock-Step Philosophy . . . . .	327
Lost In SubSpace . . . . .	328
Keep It All Together . . . . .	329
<b>Chapter 24. Sample I/O Configuration Program File . . . . .</b>	<b>331</b>
<b>Chapter 25. Understanding Dynamic I/O Return Codes . . . . .</b>	<b>335</b>
Adding, Deleting, or Changing a Channel Path . . . . .	336
Adding, Deleting, or Changing a Control Unit . . . . .	342
Adding, Deleting, or Changing an I/O Device . . . . .	350
Adding, Deleting, or Changing a PCI Function . . . . .	356
Adding or Deleting a Logical Partition (LPAR) . . . . .	358
Changing the Active IOCDS File . . . . .	360
Changing the Configuration Mode Setting. . . . .	362
Displaying All Channel Paths and Their Physical Status . . . . .	364
Displaying HSA Starting and Ending Addresses and Available HSA Space . . . . .	365
Vary a Channel Path Offline . . . . .	365
Vary a Channel Path Online . . . . .	367
<hr/>	
<b>Part 4. Appendixes . . . . .</b>	<b>369</b>

<b>Appendix. Using UIMs with z/VM HCD.</b>	<b>371</b>
<b>Notices</b>	<b>373</b>
Programming Interface Information	375
Trademarks	375
Terms and Conditions for Product Documentation	375
IBM Online Privacy Statement	376
<b>Glossary</b>	<b>377</b>
<b>Bibliography</b>	<b>379</b>
Where to Get z/VM Information	379
z/VM Base Library	379
z/VM Facilities and Features	380
Prerequisite Products	381
Additional Publications	381
<b>Index</b>	<b>383</b>



---

## Figures

1. Configuration Definition without HCD/with Multiple Files . . . . .	10
2. Single File Configuration Definition with HCD. . . . .	11
3. Configuration Definition with HCD . . . . .	14
4. Objects Managed by HCD . . . . .	14
5. Building a Production IODF and an IOCDS. . . . .	15
6. Relationship of Files Used by HCD . . . . .	16
7. Processor Configuration with Coupling Facility Implemented. . . . .	18
8. I/O Configuration to the Software . . . . .	19
9. I/O Configuration to Hardware. . . . .	21
10. Example of a z/VM HCD Profile . . . . .	30
11. IODF Distribution/Merge Process . . . . .	34
12. Example of a Configuration with One Switch . . . . .	42
13. Example of a Configuration with Two Switches (1) . . . . .	42
14. Example of a Configuration with Two Switches (2) . . . . .	43
15. Example of a Configuration with Cascading Switching . . . . .	43
16. Example of Input File for Migration Enhancements . . . . .	48
17. IOCP Migration . . . . .	82
18. IOCP Migration . . . . .	83
19. IOCP Migration . . . . .	83
20. IOCP Migration . . . . .	84
21. IOCP Migration . . . . .	84
22. IOCP Migration . . . . .	85
23. OS Migration . . . . .	86
24. OS Migration . . . . .	86
25. Partial Migration of an IOCP Input File . . . . .	110
26. Partial Migration of an IOCP Input File . . . . .	111
27. Partial Migration of an IOCP Input File . . . . .	112
28. Partial Migration of an IOCP Input File . . . . .	113
29. Partial Migration of an IOCP Input File . . . . .	114
30. Partial Migration of an OS Configuration Input File. . . . .	114
31. Example: HCD Migration Log . . . . .	116
32. Example of a Processor Summary Report . . . . .	175
33. Channel Subsystem Summary Report . . . . .	176
34. PCIe Function Summary Report . . . . .	177
35. CHID Summary Report . . . . .	178
36. Example of a Partition Report . . . . .	179
37. Example of an IOCDS Report . . . . .	179
38. Example of a Channel Path Summary Report . . . . .	182
39. Example of a Channel Path Detail Report . . . . .	185
40. Example of a CF Channel Path Connectivity Report. . . . .	186
41. Example of a Control Unit Summary Report . . . . .	187
42. Example of a Control Unit Detail Report . . . . .	188
43. Example of a Device Summary Report . . . . .	189
44. Example of a Device Detail Report (Part 1 of 2) . . . . .	191
45. Example of a Device Detail Report (Part 2 of 2) . . . . .	192
46. Example of a Switch Summary Report . . . . .	193
47. Example of a Switch Detail Report . . . . .	193
48. Example of a Switch Configuration Summary Report . . . . .	194
49. Example of a Switch Configuration Detail Report . . . . .	194
50. Example of an Operating System Summary Report . . . . .	195
51. Example of a VM Device Report . . . . .	195
52. Example of a VM Device Detail Report . . . . .	196
53. Example of a VM Console Report. . . . .	196
54. Example of a CTC Connection Report . . . . .	197
55. Sample of Diagnostic Messages coming with the CTC connection report. . . . .	198

56.	Supported Hardware Report - Processors (Part 1 of 26)	200
57.	Supported Hardware Report - Processors (Part 2 of 26)	201
58.	Supported Hardware Report - Processors (Part 3 of 26)	202
59.	Supported Hardware Report - Processors (Part 4 of 26)	203
60.	Supported Hardware Report - Processors (Part 5 of 26)	204
61.	Supported Hardware Report - Processors (Part 6 of 26)	205
62.	Supported Hardware Report - Processors (Part 7 of 26)	206
63.	Supported Hardware Report - Control Units (Part 8 of 26)	207
64.	Supported Hardware Report - Control Units (Part 9 of 26)	208
65.	Supported Hardware Report - Control Units (Part 10 of 26)	209
66.	Supported Hardware Report - Control Units (Part 11 of 26)	209
67.	Supported Hardware Report - Control Units (Part 12 of 26)	210
68.	Supported Hardware Report - Control Units (Part 13 of 26)	211
69.	Supported Hardware Report - Control Units (Part 14 of 26)	212
70.	Supported Hardware Report - Devices (Part 15 of 26)	213
71.	Supported Hardware Report - Devices (Part 16 of 26)	214
72.	Supported Hardware Report - Devices (Part 17 of 26)	215
73.	Supported Hardware Report - Devices (Part 18 of 26)	216
74.	Supported Hardware Report - Devices (Part 19 of 26)	216
75.	Supported Hardware Report - VM Devices (Part 20 of 24)	217
76.	Supported Hardware Report - VM Devices (Part 21 of 24)	218
77.	Supported Hardware Report - VM Devices (Part 22 of 24)	219
78.	Supported Hardware Report - VM Devices (Part 23 of 24)	220
79.	Supported Hardware Report - VM Devices (Part 24 of 24)	220
80.	Example of a I/O Definition Reference	221
81.	LCU Report	222
82.	Processor Compare Report	223
83.	Example of a Channel Subsystem Compare Report	224
84.	Example of a PCIe Function Compare Report	225
85.	Example of a Partition Compare Report	226
86.	Example of a Channel Path Compare Report	227
87.	Example of a Control Unit Attachment Compare Report	228
88.	Example of a Device Attachment Compare Report	229
89.	Example of a Control Unit Compare Report	229
90.	Example of a Device Compare Report	230
91.	Example of a Switch Compare Report	231
92.	Example of a Switch Detail Compare Report	232
93.	Example of a Switch Configuration Detail Compare Report	233
94.	Example of an OS Device Compare Report	234
95.	Example of an OS Console Compare Report	234
96.	CSS / Operating System Device Compare	235
97.	Example: Trace Output	247
98.	Example: Trace Output in Case of Abend	248
99.	z/VM Environment without z/OS	255
100.	Extracts from an IOCP with extended migration statements	258
101.	CBDSMIGR MESSAGES A1	260
102.	Excerpt from REALVM DECK A	262
103.	Customize Activation Profiles	265
104.	Information display from the support element	266
105.	Disable Wait 9043	267
106.	Mixed z/VM and z/OS Environment	270

---

## Tables

1.	Location of Processor Configuration Token . . . . .	22
2.	IODF Compatibility Overview . . . . .	39
3.	Dynamic I/O Offline Requirements for Device Characteristic Fields. . . . .	57
4.	Dynamic I/O Offline Requirements for Channel Path Fields . . . . .	59
5.	Dynamic I/O Offline Requirements for Control Unit Fields . . . . .	61
6.	Actions on IODF Objects. . . . .	107
7.	List of Available HCD Functions . . . . .	121
8.	Standard DD names Used by HCD . . . . .	172
9.	Symptoms of System Problems. . . . .	237
10.	Search Argument . . . . .	238
11.	Problem Data . . . . .	238
12.	Search Argument . . . . .	239
13.	Problem Data . . . . .	240
14.	Problem Data . . . . .	241
15.	Problem Data . . . . .	243
16.	Search Argument . . . . .	244
17.	Problem Data . . . . .	244
18.	Search Argument . . . . .	245
19.	Problem Data . . . . .	245
20.	Search Argument . . . . .	245
21.	Problem Data . . . . .	245
22.	Where to Find HCD Messages . . . . .	246
23.	Extended migration statements: Processors. . . . .	256
24.	Extended migration statements: Partitions . . . . .	256
25.	Extended migration statements: CHPIDs . . . . .	257
26.	Extended migration statements: Control units. . . . .	257
27.	Extended migration statements: Switches . . . . .	257



---

## About This Document

This document tells you how to plan the I/O configuration on your IBM® z/VM® system, using either HCM and HCD or the original dynamic I/O configuration capabilities of z/VM.

---

## Intended Audience

This document is intended for system administrators who wish to create and manage a z/VM I/O configuration.

---

## Where to Find More Information

See “Bibliography” on page 379 at the back of this document.

## Links to Other Documents and Websites

The PDF version of this document contains links to other documents and websites. A link from this document to another document works only when both documents are in the same directory or database, and a link to a website works only if you have access to the Internet. A document link is to a specific edition. If a new edition of a linked document has been published since the publication of this document, the linked document might not be the latest edition.



---

## How to Send Your Comments to IBM

We appreciate your input on this publication. Feel free to comment on the clarity, accuracy, and completeness of the information or give us any other feedback that you might have.

Use one of the following methods to send us your comments:

1. Send an email to [mhvrcfs@us.ibm.com](mailto:mhvrcfs@us.ibm.com).
2. Go to IBM z/VM Reader's Comments ([www.ibm.com/systems/z/os/zvm/zvmforms/webqs.html](http://www.ibm.com/systems/z/os/zvm/zvmforms/webqs.html)).

Include the following information:

- Your name
- Your email address
- The publication title and order number:  
**z/VM V6.3 I/O Configuration**  
**SC24-6198-05**
- The topic name or page number related to your comment
- The text of your comment

When you send comments to IBM®, you grant IBM a nonexclusive right to use or distribute your comments in any way it believes appropriate without incurring any obligation to you.

IBM or any other organizations will use the personal information that you supply only to contact you about the issues that you submit to IBM.

### If You Have a Technical Problem

Do not use the feedback methods listed above. Instead, do one of the following:

- Contact your IBM service representative.
- Contact IBM technical support.
- See IBM: z/VM Service Resources ([www.ibm.com/vm/service/](http://www.ibm.com/vm/service/)).
- Go to IBM Support Portal ([www.ibm.com/support/entry/portal/Overview/](http://www.ibm.com/support/entry/portal/Overview/)).



---

## Summary of Changes

This document contains terminology, maintenance, and editorial changes. Technical changes or additions to the text and illustrations are indicated by a vertical line to the left of the changes. Some program updates might be provided through z/VM service by program temporary fixes (PTFs) for authorized program analysis reports (APARs), which also might be available for some prior releases.

---

### SC24-6198-05, z/VM Version 6 Release 3 (February 2016)

This edition includes changes to support product changes provided or announced after the general availability of z/VM® V6.3.

#### IBM z13 (Driver D27) and z13s Compatibility I/O Support

z/VM compatibility support for the IBM z13™ (driver D27) and IBM z13s™ includes support for dynamic I/O and guest usage of the new Internal Shared Memory (ISM) PCI function type for Shared Memory Communications - Direct Memory Access (SMC-D) connectivity.

Chapter 25, “Understanding Dynamic I/O Return Codes,” on page 335 has been updated for this support. For more information, see “Adding, Deleting, or Changing a PCI Function” on page 356.

#### Hardware Support

##### Support of new PCIe functions

Two new PCIe function types are supported - ISM and RCE. See “PCIe Function” on page 96.

1. An ISM (Internal Shared Memory) network adapter allows a virtual PCIe function requiring a unique VCHID with up to 255 virtual function Ids. The ISM network adapter allows one PNETID to be specified which has to be identical for all virtual functions of a VCHID.
2. An RCE (Regional Crypto Enablement) function is used for all vendor Open Crypto adapters.

##### Validation enhancement

At Build production time it is checked if for those PCIe functions using PNETIDs a channel path exists which is accessing at least one identical LPAR and has the same PNETID defined. Chpids and PCIe functions requiring a VCHID (currently CHPID of type IQD and function of type ISM) now require a processor unique PNETID.

##### Processor support

HCD supports the IBM® z13 processor family:

- processor types 2964-N30, -N63, -N96, -NC6, -NE1 (new support level H160310)
- processor types 2964-L30, -L63, -L96, -LC6, -LE1 (support level H160310)
- processor types 2965-N10 and N20 (support level H160310).
- processor types 2965-L10 and L20 (support level H160310).

---

## SC24-6198-04, z/VM Version 6 Release 3 (May 2015)

This edition includes changes to support product changes provided or announced after the general availability of z/VM V6.3.

### **z13 Compatibility I/O Support**

The z13 Compatibility I/O Support item supports new I/O related architectures so the new features can be exploited by z/VM guests and users of dynamic I/O.

Chapter 25, "Understanding Dynamic I/O Return Codes," on page 335 has been updated for this support.

#### **New Hardware Support**

##### **Support 6 Channel Subsystems and 4 Subchannel Sets**

For the new processor type the maximum number of channel subsystems is extended to 6 and the number of subchannel sets is increased.

##### **PCIe function enhancements**

With processor z13 the PCIe functions of type ROCE now require a virtual number definition and allow only 2 PNET ID for its external physical network assignments.

##### **VCHID support for internal channels**

For internal channel paths, like IQD and ICP CHPIDs, there does not exist a physical correspondence to hardware, hence there does not exist a PCHID value. Instead a unique virtual channel ID (VCHID) is assigned. The VCHID value is arbitrary out of a range which is beyond the range of valid PCHID values.

##### **New CS5 chpid type**

A new CHPID type CS5 based on PCIe technology is supported.

##### **Processor support**

HCD supports the IBM® z13 processor family (processor types 2964-N30, -N63, -N96, -NC6, -NE1)

---

## SC24-6198-03, z/VM Version 6 Release 3

This edition includes changes to support product changes provided or announced after the general availability of z/VM V6.3.

### **PCIe Guest Direct Attach Support**

The PCIe Guest Direct Attach provides support for PCI adapters for z/VM.

"PCIe Function" on page 96 is added for this support.

Chapter 25, "Understanding Dynamic I/O Return Codes," on page 335 has been updated for this support.

### **New HCD Reports**

The following new HCD reports are provided:

- The "PCIe Function Summary Report" on page 176 displays the partitions in the access and candidate lists which are entitled to access the available PCIe functions.
- The "PCIe Function Compare Report" on page 225 show the changes of PCIe functions between processors of two IODFs.

- The “CHID Summary Report” on page 178 as part of the “Channel Subsystem Summary Report” on page 175 lists all defined channel paths and PCIe functions grouped by their defined PCHID values or, as applicable, by their HCA adapter or port IDs.

## Hardware Support

HCD supports the IBM zEnterprise EC12 and BC12 (zEC12 and zBC12) processor family (processor types 2827-H20, -H43, -H66, -H89, -HA1 and 2828-H06, -H13).

---

## SC24-6198-02, z/VM Version 6 Release 2

This edition includes changes or additions to support the general availability of z/VM V6.2.

## Enhancement of the CSS/OS Device Compare Report

The *CSS/OS Device Compare* report displays the subchannel set ID for devices or device ranges which are located in a subchannel set with a subchannel set ID > 0.

## New Classification for Severe Warning Messages

To distinguish the severity of warning messages when building the production IODF, HCD introduces a new severity classification S in the Message List (when working in the HCD dialog) or in the HCD message log (when working in batch processing). This classification designates severe warning messages that users should carefully consider. Though these messages do not cause a function failure, the reason for these messages may lead to undesirable results.

## New REXX Utility to Support Configuration Packages

HCD provides a new REXX utility which lets you work with configuration packages. The utility lets you specify a source production IODF, a new target production IODF, target user ID, OS and node, and control files for processor, OS and switch configurations that are to be extracted from the source IODF and packaged in the target IODF. The target IODF is then sent to the specified user ID/node. This utility does not require the definition of a configuration package in the source IODF.

## New Profile Options

There are two new keywords that you can specify in the HCD profile for the following purpose:

- ***Delay device regrouping:*** You can specify that HCD should perform any necessary device regrouping after a device group split only when the IODF is closed. This gives a better response time in the HCD dialog for large IODFs, because HCD per default performs a necessary device regrouping each time when exiting the I/O Device List.
- ***Showing partition information in IOCP decks:*** Use profile option SHOW\_IOCP\_DEFAULTS to explicitly show and document the partition defaults of CHPID and IODEVICE statements in generated IOCP decks. The option causes HCD to write this additional information as comments into the IOCP deck.
- ***Extend the change log data set to provide space for updates:*** Use profile option CHLOG\_EXTENSION to specify the percentage of additional space that is to be allocated beyond the default size of the IODF when a change log data set is created.

- *Export/import additional configuration objects:* You can use a new profile option `SHOW_CONFIG_ALL` to let the Build I/O configuration data function write configuration statements for unconnected control units and devices, in addition to those for switches.

## Changes in HCD Reports

The following HCD reports are enhanced:

- The *Control Unit Summary Report* now shows the number of logical paths per control unit.
- The *Control Unit Detail Report* now shows the number of logical paths for a control unit per channel subsystem and the number of logical paths per control unit port.
- For the *Processor Compare Report*, HCD now also compares the processor tokens of work/production or work/work IODFs. In previous releases, HCD compared only the tokens of production IODFs.
- In the *CSS/OS Device Compare Report*, devices with adjacent ranges are joined before printing. Additionally the device range is increased to show a maximum of 4 digits.

## Support of the WWPN Prediction Tool

From the currently accessed IODF, you can export the FCP channel/device specific part of the I/O configuration into a comma-separated value (CSV) output format. The generated file can be used as input to the WWPN Prediction Tool to assign world-wide port names to virtualized FCP ports for configuring SAN devices.

## Hardware Support

- HCD supports the IBM z10™ EC processor family (processor types 2097-E12, -E26, -E40, -E56, -E64).

Selecting a 2097-type processor creates a maximum logical processor configuration. That is, HCD generates a processor configuration with four channel subsystems and 15 reserved partitions in each channel subsystem. Also, HCD generates two subchannel sets in each of the four channel subsystems and provides for the maximum number of devices in each subchannel set.

- HCD supports the IBM z10 BC processor (processor type 2098-E10).
- For the z/TPF operating system, 3215 consoles are supported on channel paths of type OSC. IOCP needs to distinguish between OSC-3270 and OSC-3215 attachments. This is done via the `CHPARM` keyword on the `CHPID` statement.

---

## SC24-6198-01, z/VM Version 6 Release 1 (Updated Edition)

This edition includes changes to support product changes provided or announced after the general availability of V6.1.

## Support for OSX and OSM Channel Path Identifiers

z/VM V6.1 supports two new System z channel path ID (CHPID) types, OSX and OSM, that have been added to support the intraensemble data network (IEDN) and the intranode management network (INMN). These new CHPID types are based on the existing OSA Direct Express (OSD) channel path.

The following dynamic I/O return codes have been modified for this support:

- Return code X'0119' - Adding a Channel Path
- Return code X'0105' - Adding an I/O Device

---

## **SC24-6198-00, z/VM Version 6 Release 1**

This edition includes changes or additions to support the general availability of z/VM V6.1.

### **Architecture Level Set to System z10**

z/VM version 6 requires a new architecture level set (ALS) from z/VM version 5 and supports the IBM System z10<sup>®</sup> Enterprise Class (z10 EC) and System z10 Business Class (z10 BC).

As part of this architecture level set, processors will now run only in logical partitioned (LPAR) mode, and no longer in basic mode.



---

## Part 1. Introduction

You should read Part 2, “Using HCM and HCD,” on page 5 if you choose to use the Hardware Configuration Manager (HCM) and Hardware Configuration Definition (HCD) components of z/VM to create and manage your z/VM I/O configuration. These components provide a comprehensive I/O configuration management environment similar to that available with the z/OS® operating system. This section primarily describes HCD — for information on HCM, see *z/OS and z/VM: Hardware Configuration Manager User’s Guide*.

You should read Chapter 15, “Migration Scenarios to z/VM HCD for z/VM and z/OS,” on page 255 if you are interested in migrating to HCD in a z/VM environment without z/OS, or migrating to HCD in a mixed z/VM and z/OS environment (this includes information on how to exchange IODF or IOCP files between z/VM and z/OS).

You should read Part 3, “Using Dynamic I/O Configuration,” on page 275 if you choose to use z/VM’s dynamic I/O configuration commands to make I/O configuration changes to the server on which your z/VM system is running. These commands are a partial alternative to using the newer HCM and HCD functionality. For the alternatives to HCM and HCD for creating the I/O configuration of your server hardware and for creating and managing the software I/O configuration of your z/VM system, see *z/VM: CP Planning and Administration* and the *IOCP User’s Guide* that is appropriate for your processor.



---

## Chapter 1. Overview

---

### What are HCM and HCD?

HCM and HCD are programs that work together to help you create and manage the hardware and software aspects of your z/VM system.

HCM runs on a Windows-based personal computer connected to the z/VM system via a TCP/IP network connection, and gives you a graphical user interface to help you configure your system. You provide the needed I/O configuration information to HCM, which processes the information and passes it to HCD.

HCD runs in a z/VM server virtual machine and performs the work of actually creating and changing the hardware and software aspects of your I/O configuration. While HCM provides the primary user interface to HCD, HCD also provides a back-up user interface on your z/VM host for certain I/O configuration tasks, in case HCM is not available.

HCM and HCD on z/VM can be used to create and manage both the hardware and software aspects of the I/O configuration for all servers and their logical partitions (LPARs). The resulting configuration repository containing all definitions (the IODF) can then be distributed to all systems or shared on a central disk. At that point, the IOCDs are written locally and the SYSTEM CONFIG files must be updated.

Besides the necessary system-unique differences between HCD on z/VM and HCD on z/OS, HCD on z/VM does not provide the host-dialog user interface of HCD on z/OS. Rather, HCM is provided as the primary user interface to HCD on z/VM.

**Note:** The unit-information modules (UIMs) needed for z/OS software-configuration support are not in the z/VM version of HCD. Therefore, you cannot define a z/OS software configuration using HCD on z/VM. If you have a mixed environment with z/VM and z/OS systems on a single server, use HCD on a z/OS system as the central place for I/O configuration definition both for the hardware and for the z/VM and z/OS software definitions. You must then export the resulting production IODF to any other z/OS systems and to the z/VM systems for activation (or, alternatively, for some or all of the z/OS systems, you can share the IODF via shared disk).

---

### What is Dynamic I/O Configuration?

z/VM's original dynamic I/O configuration capability consists of a set of system operator commands for changing the server's I/O configuration while the system continues to run. As with HCM and HCD, the dynamic I/O configuration commands can be used to manage the hardware I/O configuration of all of the logical partitions in your server.

---

## Choosing One Way to Work

The use of HCM and HCD is incompatible with the older methods of creating and managing your I/O configuration with z/VM. You should choose one method or the other and stay with it for the duration of any given IPL of your z/VM system. You might continue to use the traditional methods as you study and learn about HCM and HCD or, if you are a new user of z/VM, we recommend you begin immediately with the graphical interface and total environment of HCD and HCM. Knowledgeable users of the older methods might find it easier and faster to make informal I/O configuration changes, but typically you will want the more controlled environment of HCM and HCD for such changes.

---

## One-Time Disablement of HCM and HCD

It is not possible to mix the use of HCM and HCD, within a given IPL of z/VM, with the use of the older methods of I/O configuration in z/VM. You can switch from HCM and HCD to the older methods, however, on a one-way, one-time basis. Note that if you do this, it is not possible to switch back to HCM and HCD. You must re-IML your machine (thereby taking down all logical partitions if the machine is logically partitioned) to get back to the use of HCM and HCD.

---

## Part 2. Using HCM and HCD

This part explains the features of z/VM HCD and describes how to use them.

The following topics are handled:

- Chapter 2, "Introduction to HCM and HCD," on page 7
- Chapter 3, "Hardware Configuration Definition - What Is It?," on page 9
- Chapter 4, "I/O Configuration Definition Process," on page 19
- Chapter 5, "How to Set Up and Customize z/VM HCD," on page 25
- Chapter 6, "How to Work with I/O Definition Files," on page 31
- Chapter 7, "How to Work with Switches," on page 41
- Chapter 8, "How to Activate or Process Configuration Data," on page 45
- Chapter 9, "How to Print and Compare Configuration Data," on page 69
- Chapter 10, "How to Migrate your Environment to z/VM HCD," on page 75
- Chapter 11, "How to Migrate Existing Input Files," on page 79
- Chapter 12, "How to Invoke the HCD Functions," on page 119
- Chapter 13, "Configuration Reports," on page 175
- Chapter 14, "Problem Determination," on page 237
- Chapter 15, "Migration Scenarios to z/VM HCD for z/VM and z/OS," on page 255



---

## Chapter 2. Introduction to HCM and HCD

Today, z/VM customers accomplish I/O definition tasks by using IOCP directly, issuing CP line commands, and editing the SYSTEM CONFIG file. Only very basic rule checking is provided. In particular, IOCP does not support specific device and control unit checking. In general, under z/VM, validation does not take place at data-entry time, but during IOCP input deck processing, IPL or dynamic activate.

z/VM supports the System/390 hardware dynamic I/O configuration facility. This facility allows you to dynamically add, delete or modify the I/O configuration of the processor without requiring a power-on reset of the processor or IPL of z/VM.

z/VM's support allows the system administrator or system operator to issue privileged CP commands to dynamically alter the I/O configuration of the processor without the need of an IPL of z/VM or a power-on reset of the processor.

The current method of issuing CP line commands is burdened with the following disadvantages:

- There is no automatic lock-step mechanism for dynamic I/O configuration. With dynamic I/O configuration, the changes must be applied to the current IOCDS as well as to the I/O configuration of the running system using CP line commands. These two processes are separated. That means, for example, that CP line commands must be manually entered in a predefined order. If for example, you run into errors without having recorded all the commands that you have already issued, it may be very cumbersome to return to the previous status to repeat the correct series of commands.
- There is less validation of the consistency of the IOCDS with the current I/O configuration. z/VM allows you to apply dynamic I/O configuration changes to the running system without propagating these changes to the related IOCDS. Therefore, the changes are lost in case of an unplanned POR.
- There are few reporting and comparison facilities about I/O configurations.

These disadvantages are avoided by using the facilities of z/VM HCD, which helps you to specify I/O configuration definitions on z/VM in a comfortable way, automatically ensure consistency of IOCDS and active I/O configuration, including data validation at data-entry time, thus avoiding repeated IPLs.

z/VM HCD is used to define the hardware configuration to the Channel Subsystem and to the operating system. The defined configuration may consist of multiple processors, each containing multiple logical partitions. z/VM HCD stores the entire configuration data in a central repository, the I/O Definition File (IODF). The IODF as single source for all hardware and software definitions for a multi-processor or LPAR system eliminates the need to maintain several independent IOCP files and configuration files containing definitions for the operating system. That means, the configuration is defined only once.

The I/O configuration is validated at the time of entry rather than at the next IML/IPL or activation time. The validation function ensures that each newly entered I/O definition is consistent with the already existing I/O definitions in the IODF. Furthermore, it is checked if the user specifications are consistent with the specifications of the hardware.

z/VM HCD replaces the current process for defining the I/O configuration to the z/VM software (device sensing and/or specification of RDEVICE statements) and hides the IOCP process for the supported processor families. When a z/VM user chooses to use z/VM HCD for configuration definition, this program will build the IOCDs that is used for IML. During IPL, z/VM CP reads the IODF for the VM configuration. Device data are taken from the IODF to complete the RDEV control blocks. Dynamic hardware and software changes are also done via z/VM HCD that interfaces with the CP dynamic activate function. Using z/VM HCD will ensure that the user has a consistent I/O configuration.

Another main goal of z/VM HCD is to support customers who run Linux images as z/VM guests and have limited I/O configuration skills.

---

## Components and Terminology

z/VM HCD consists of the following components:

- HCD ported from z/OS to be running on the z/VM host.
- HCM running on a windows workstation (for more information about workstation prerequisites, refer to the *z/OS and z/VM: Hardware Configuration Manager User's Guide*).
- the z/VM HCD TCP/IP dispatcher for HCM which performs the communication between z/VM HCD and HCM (see also "Setting Up the z/VM HCD TCP/IP Dispatcher for HCM" on page 25).

z/VM HCD exploits the features of z/OS HCD (Hardware Configuration Definition) and HCM (Hardware Configuration Manager).

- z/VM HCD is an I/O configuration definition tool for z/VM customers which validates channel subsystem and operating system definition at data-entry time. z/VM HCD is responsible for creating and maintaining the I/O Definition File (IODF) which is the optional I/O configuration repository of z/VM.

**Note:** In this book, the term HCD is often used as an abbreviation for z/VM HCD and exactly denotes those facilities from z/OS HCD that have been ported to z/VM HCD.

- HCM offers an interactive user interface to HCD, which displays the I/O topology defined in the IODF graphically. HCM runs on a Windows workstation and needs an HCD instance running on the host for manipulating I/O configuration definitions in the IODF.

The features of z/OS HCD that are exploited by z/VM HCD are described in this part. For more information on HCM, refer to *z/OS and z/VM: Hardware Configuration Manager User's Guide*.

---

## Chapter 3. Hardware Configuration Definition - What Is It?

### Overview

To understand z/VM HCD and how it helps you in defining the hardware configuration of a system, this chapter explains the following topics:

- “What HCD Is and How It Differs from IOCP and VM Configuration Definition”
- “What HCD Offers You” on page 12
- “How HCD Works” on page 13
- “The Environment in which z/VM HCD Operates” on page 16

---

### What HCD Is and How It Differs from IOCP and VM Configuration Definition

The channel subsystem (CSS) and the operating system need to know what hardware resources are available in the computer system and how these resources are connected. This information is called *hardware configuration*.

z/VM HCD uses a graphical interactive interface, HCM, which allows you to define the hardware configuration for both a processor's channel subsystems and the operating system.

Before HCD was available, you had to use IOCP to define the hardware to the channel subsystem, and in specific cases, the RDEVICE statements to define the hardware to the operating system. The following sections explain in what way HCD differs from this process when defining, validating and reconfiguring configuration data.

### Definition of Configuration Data

#### Device Sensing

Most IBM devices can be queried (sensed) to determine what type of device they are. This is done at IPL time and when a device is varied on. For example, assume you have an IBM 3380 DASD device at address 300. CP issues a sense ID command to device 300. The device returns information indicating that it is a 3380 type.

CP may need more information than that returned by some devices when they are queried. An example of this type of device is the IBM 4248 printer. When queried, the printer returns only the information that it is a 4248. Necessary information such as the printer class and the forms control buffer to be used is not provided via sensing; if CP is not provided this information on an RDEVICE statement, CP uses default values for that type of printer.

If a device does not respond to the device sense ID command, then the device must be defined in the system configuration file using the RDEVICE statement. An example of such a device is the IBM 3420 tape drive. This tape drive could be defined like this in the system configuration file:

```
RDEVICE xxxx TYPE 3420 MODEL 8 DUAL_DENSITY YES
```

For more information on device sensing refer to *z/VM: CP Planning and Administration*.

## How VM Configuration Worked

With RDEVICE statements and IOCP you were limited to defining one processor or operating system per input file. This meant that you needed more than one file in a multi-CPC environment with multiple partitions when you used IOCP and RDEVICE statements.

Figure 1 illustrates the definition process using several sources for writing and modifying the hardware configuration using IOCP files.

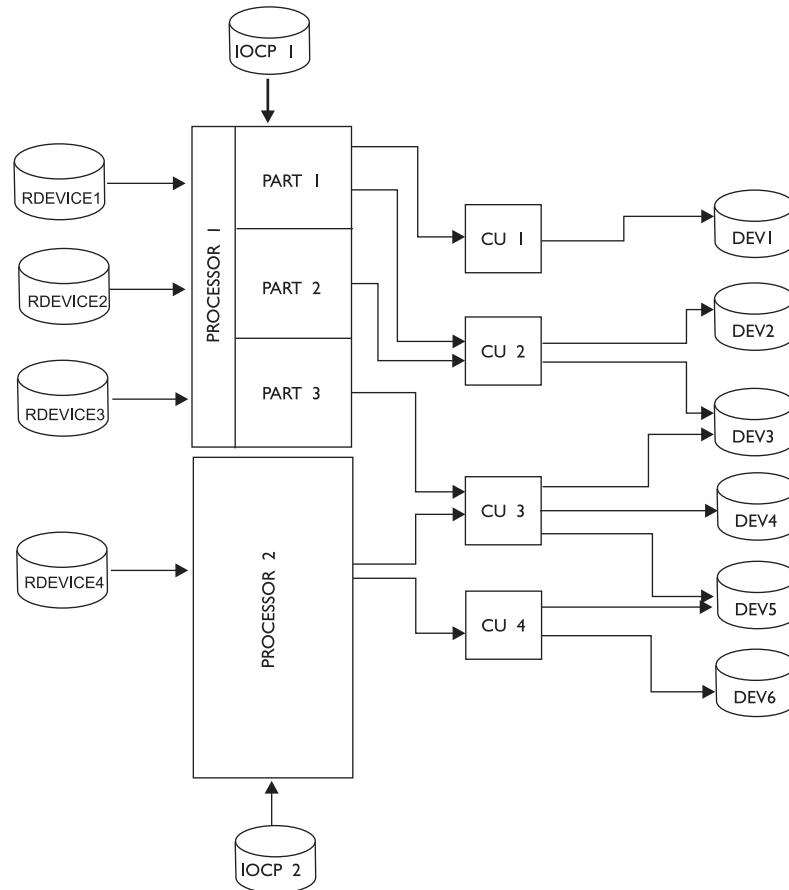

Figure 1. Configuration Definition without HCD/with Multiple Files

## What HCD Does

The configuration you define with HCD may consist of multiple processors with multiple channel subsystems, each containing multiple partitions. HCD stores the entire configuration data in a central repository, the *input/output definition file (IODF)*. The IODF as single source for all hardware and software definitions for a multi-CPC or multi-partition system eliminates the need to maintain several independent IOCP files and collections of RDEVICE statements. That means that you enter the information only once using an interactive graphical interface.

Figure 2 on page 11 illustrates the definition process using one source for writing and modifying configuration data in the IODF:

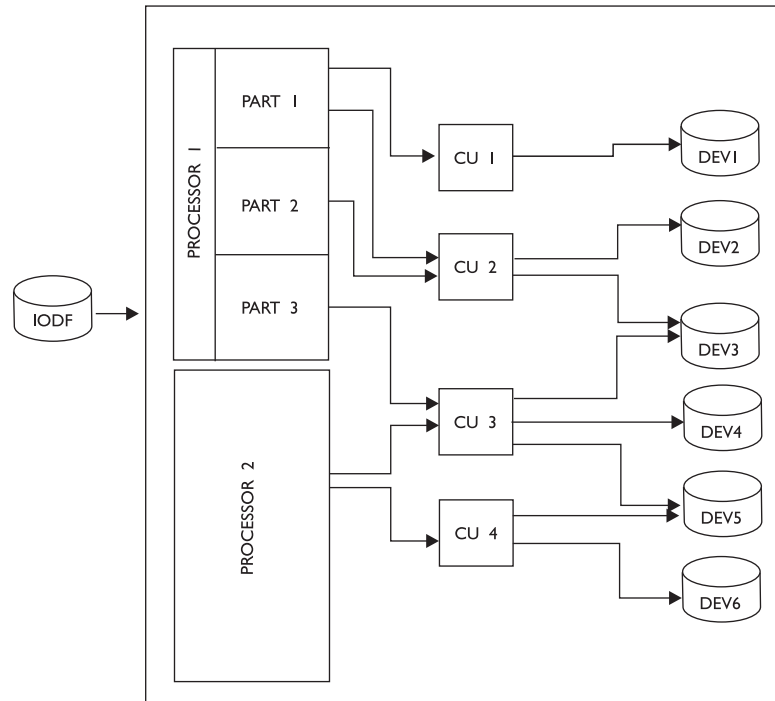

Figure 2. Single File Configuration Definition with HCD

## Validation of Configuration Data

### How IPL and IOCP Worked

IPL and IOCP were separately running independent processes. Prior to IPL it was not checked whether the RDEVICE statements matched the configuration in the I/O configuration data set (IOCDS). Even if the definitions of both processes were not identical, it was possible for an IPL to be successful if the devices needed to start the system were included in both programs. Therefore, discrepancies would be detected only after the system had been running for some time. Such a discovery could have happened at a very inconvenient moment.

### What HCD Does

The data entered with HCD is validated and checked for consistency and completeness. Because the check is performed when the data is defined, rather than when the device is accessed, inconsistencies can be corrected right away, and unplanned system outages resulting from inconsistent definitions can be avoided.

If you include ESCON<sup>®</sup> or FICON<sup>™</sup> Director definitions in the IODF, HCD also validates the switch port usage and connection information for all devices and channels connected to each of the directors in the configuration. In addition, HCD validates the complete path from the processor through the switch to the control unit and device.

## Reconfiguration of Configuration Data

### How VM and IOCP Worked

The IOCP updated the input/output configuration data set (IOCDS) that resided in the hardware support processor. This information was loaded into the hardware

system area during power-on reset (POR). Without dynamic reconfiguration of CP, if the configuration was changed, it was necessary to write a new IOCDS using IOCP and to load it into the hardware system area with a POR.

CP created the control information (such as RDEV control blocks) needed by z/VM to describe the hardware configuration.

Dynamic reconfiguration management is the ability to select a new I/O configuration during normal processing and without the need to perform a power on reset (POR) of the hardware or an initial program load (IPL) of the operating system.

**z/VM Dynamic I/O Configuration:** In z/VM, dynamic I/O configuration is the user's responsibility:

- You have to enter the CP line commands in a correct sequence to accomplish the desired configuration change.
- To handle problems, you need to establish a manual roll-back process. For example, you have to record the series of already entered commands to be able to step back to a defined status before a retry.

### What HCD Does

The ability of HCD to provide equivalent hardware and software I/O definitions and to detect when they are not in sync is essential for dynamic I/O reconfiguration management. HCD compares both the old and the new configuration and informs the hardware and software about the differences. You may add, delete, and modify definitions for channel paths, control units and I/O devices without having to perform a POR or an IPL.

**Advantages of HCD:** For the dynamic I/O reconfiguration, HCD offers you the following advantages:

- **Automatic lock-step approach:** All dynamic changes to the I/O configuration are also applied to the current IOCDS. After actually performing dynamic changes on the running system, the changes are applied to the prospective IOCDS, that is, if the dynamic hardware change is successful, the new IOCDS is written to the support element and is thus available for the next POR.
- **Automatic backout and recovery capabilities:** If in the middle of a sequence of dynamic changes a single change fails, all steps processed before the failure are automatically undone and a consistent configuration state is reached. Also, if CP is unable to complete a dynamic activate request because it is disrupted, the next time the system is up again, stored recovery information allows continuing or backing out the original activation sequence.
- **Check whether hardware and software configuration definitions are consistent:** Consistency between hardware and software configuration is guaranteed via unique tokens. Read more about the advantages that HCD provides in this area in "Ensuring that the Software and Hardware Definitions Match" on page 21.

---

## What HCD Offers You

**Single Point of Control:** With HCD you have a single source, the IODF, for your configuration data. This means that hardware and software definitions can be done from HCD and can be activated with the data stored in the IODF.

**Increased System Availability:** HCD checks the configuration data when it is entered and therefore reduces the chance of unplanned system outages due to inconsistent definitions.

**Consistently changing Hardware Definitions Dynamically:** HCD offers a lock-step approach to dynamic I/O reconfiguration management. This function allows you to change your hardware and software definitions on the fly - you can add devices, or change devices, channel paths, and control units, without performing a POR or an IPL. You may also perform software-only changes, even if the hardware is not installed.

**Migration Support:** HCD offers a migration function that allows you to migrate your current configuration data from IOCP and HCPRIO files and RDEV control blocks into HCD. Migration support also allows you to make bulk changes to the configuration using an editor on such I/O configuration macro statements.

**Accurate Configuration Documentation:** The actual configuration definitions for one or more processors in the IODF are the basis for the reports you can produce with HCD. This means that the reports are accurate and reflect the up-to-date definition of your configuration.

HCD provides a number of textual reports and graphical reports. The printed output can be used for documentation purposes providing the base for further configuration planning tasks. The display function allows you to get a quick overview of your logical hardware configuration.

**Guidance through Interactive Interface:** HCM provides a graphical and interactive user interface, based on Windows, that supports both the hardware and the software configuration definition functions. The primary way of defining the configuration is through HCM. The configuration is done from a diagram or from data entered in the dialogs.

HCM offers extensive online help and prompting facilities. Help includes information about dialogs, commands, data displayed, available actions, and context-sensitive help for input fields. A fast path for experienced users is also supported.

**REXX Utilities:** In addition to the interactive interface, z/VM HCD also offers a number of REXX utilities. You can use these utilities, for instance, to migrate your existing configuration data; to maintain the IODF, to dynamically activate the configuration, or to print configuration reports. For a complete list of available REXX utilities, refer to Chapter 12, "How to Invoke the HCD Functions," on page 119.

---

## How HCD Works

HCD stores the hardware configuration data you defined in the IODF. A single IODF can contain definitions for several processors (or LPARs) and several z/VM operating systems. It contains all information used to create IOCDSs and the information necessary to build the RDEVs. When HCD initiates the function to build the IOCDS, the IODF is used as input. The IOCDS with the channel subsystem definitions of a processor is then used to perform POR. The same IODF is used by z/VM to read the configuration information directly from the IODF during IPL. If your environment includes z/OS and z/VM on different processors or as logical partitions on the same processor, on z/OS the IODF can be used to create an z/OS and z/VM configuration. Therefore, you can use the z/VM configuration created on z/OS and send it to z/VM to be used there.

**Note:** On z/VM you cannot define a z/OS configuration.

Figure 3 shows an example of a configuration using HCD.

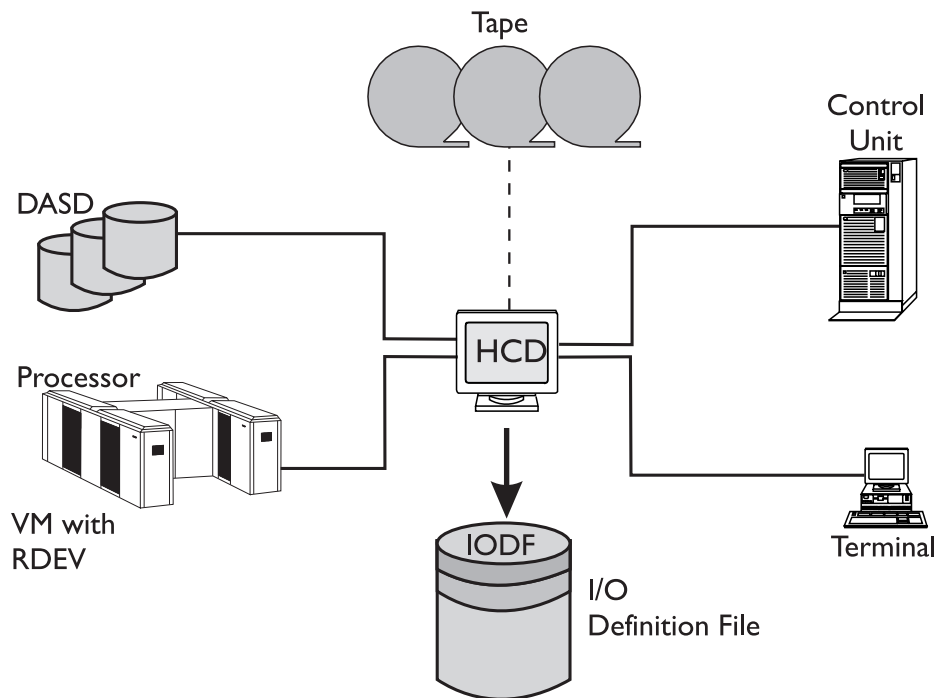

Figure 3. Configuration Definition with HCD

## Objects Managed in the IODF

HCD lets you define the configurations as objects and their connections. The following objects and their connections are managed by HCD:

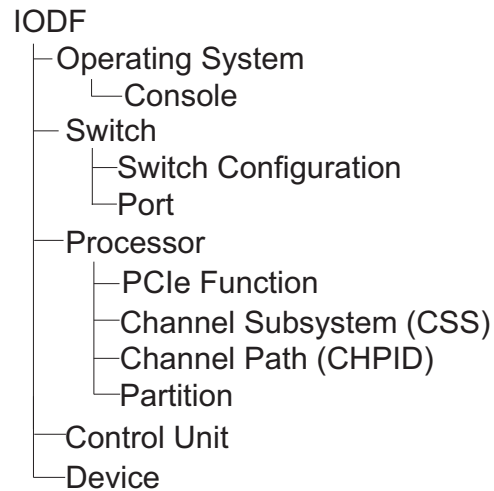

Figure 4. Objects Managed by HCD

HCM provides dialogs for all these objects, where you can define the characteristics and the relation between the objects.

## IODF Used at IPL

After you complete the input of your configuration data, you have to build a production IODF. The production IODF is used by the operating system to build the configuration data at IPL time. This active production IODF is used for building the IOCDs.

Figure 5 illustrates the build phase of a production IODF and of an IOCDs.

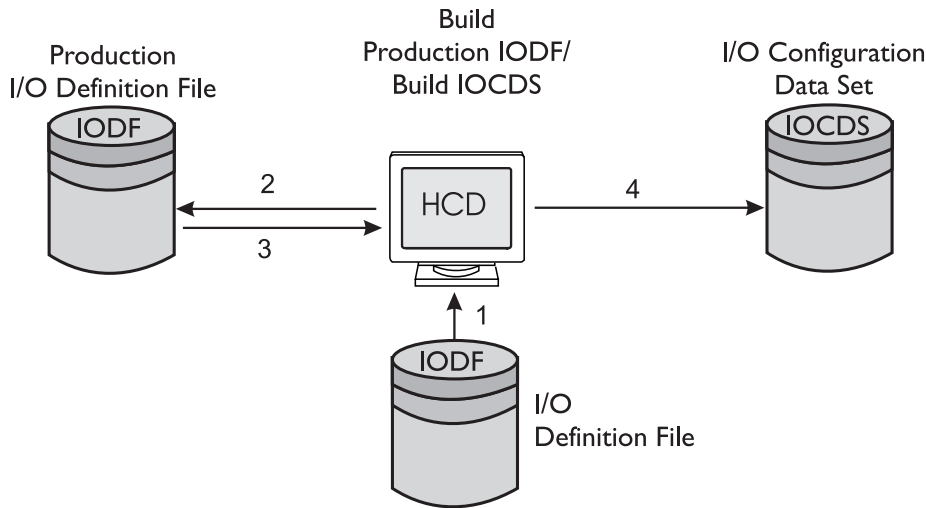

Figure 5. Building a Production IODF and an IOCDs

The production IODF cannot be updated (read-only). This ensures that the data in the production IODF used at IPL remains the same during the run time of that system.

## Relationship of Files Used by HCD

Figure 6 on page 16 shows the relationship between the files used by HCD and how you can work with or change these files.

By using the define and modify tasks or by migrating IOCP, and HCPRIO input files or RDEV control blocks, you create a work IODF. After finishing the definition, you build a production IODF from your work IODF, which you can use to IPL your system or to activate your configuration dynamically. The files shown at the bottom of the figure are created by the appropriate tasks like *Build IOCDs* and *Build IOCP input files*.

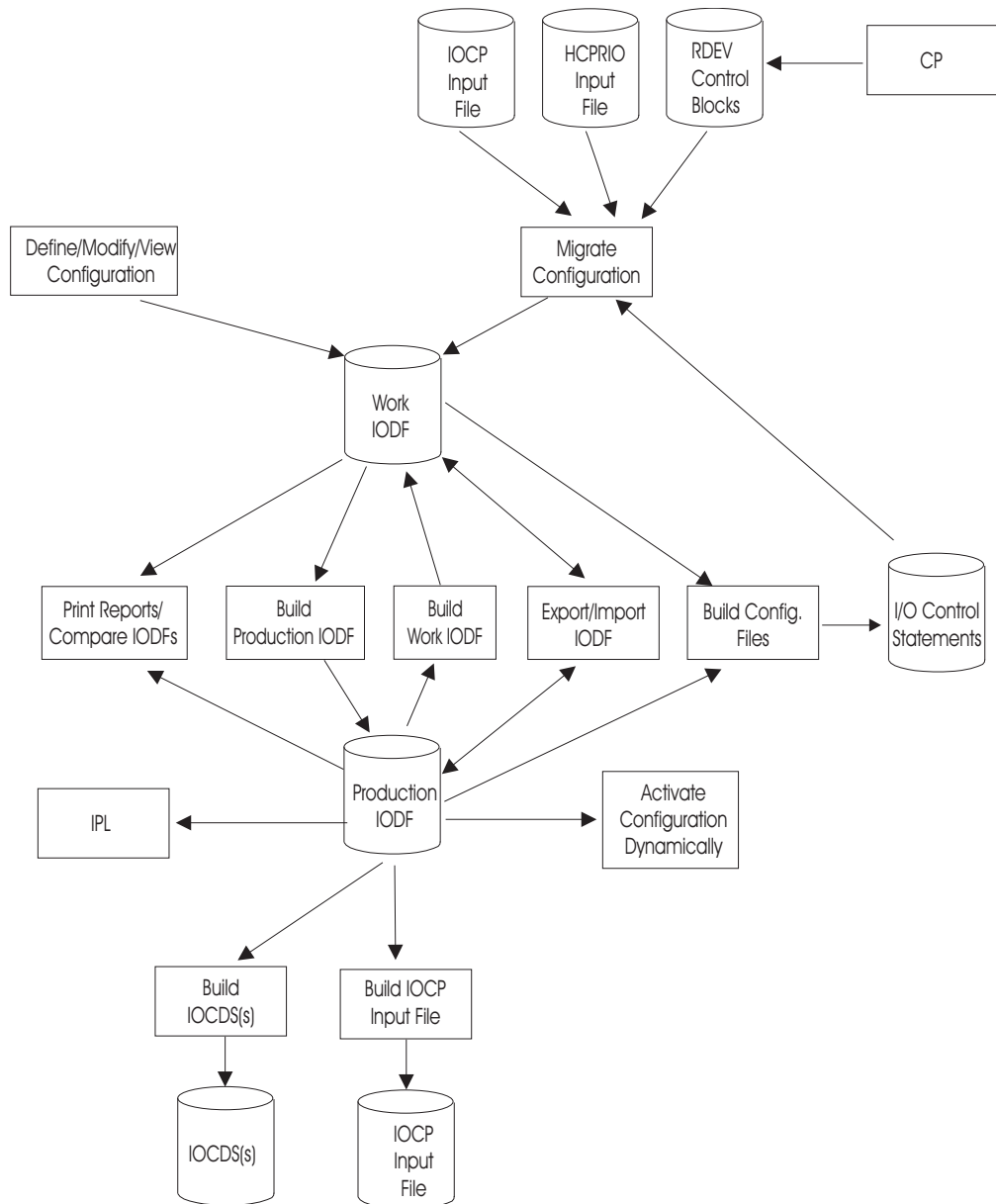

Figure 6. Relationship of Files Used by HCD

## The Environment in which z/VM HCD Operates

z/VM HCD is part of z/VM. It needs a running z/VM system before it can be used to define a hardware configuration.

The intrinsic HCD part of z/VM HCD runs in a CMS XC virtual machine. When using IODFs in data space, the virtual machine must be enabled for multiple address spaces (XCONFIG ADDRSPACE *directory\_entry*). The size of the CMS virtual machine must be at least 16 MB.

To invoke certain HCD functions, you need certain privileges:

Function	Privilege Class
<i>Build an IOCDS or an IOCP input file</i>	C, F, G
<i>Activate an IODF</i>	B, C, F, G
<i>Generate I/O configuration file from control blocks</i>	C or E

z/VM HCD uses unit information modules (UIMs) for the device support. UIMs contain device dependent information, such as parameters and features of devices. The z/VM UIMs are part of z/VM HCD.

UIMs are provided for the IBM devices supported by z/VM. You can write your own UIMs for non-IBM devices. For more information on UIMs, see *z/OS MVS Device Validation Support*. To use with z/VM HCD, see “Using UIMs with z/VM HCD,” on page 371.

## z/VM HCD and the Coupling Facility

z/VM HCD supports processors that have coupling facility capability.

The coupling facility itself is implemented as an extension to PR/SM™ features on selected processors and runs in a PR/SM partition. It enables direct communication between processors through a specific communication partition (coupling facility partition), connected by coupling facility channels. For more information on which processors have coupling facility capability, refer to the appropriate *IOCP User's Guide*.

You use z/VM HCD to specify whether a logical partition is running a coupling facility or an operating system. New channel path definitions in the IODF are used to connect a coupling facility-capable processor to a coupling facility partition:

- The coupling facility receiver channel path that accesses the partition the coupling facility is running on.
- The coupling facility sender channel path that accesses the partition the operating system is running on.
- The coupling facility peer channel path that accesses either partition bidirectionally.

HCD automatically generates the coupling facility (CF) control unit and devices that are necessary for the IOCP. Figure 7 on page 18 shows a processor configuration with coupling facility implemented.

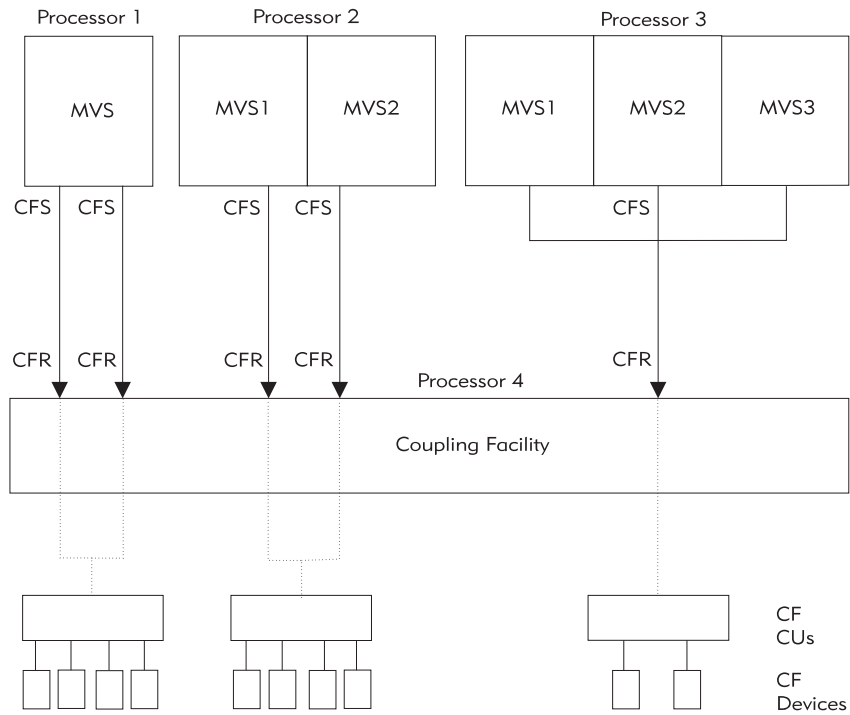

Figure 7. Processor Configuration with Coupling Facility Implemented

HCD enables you to dynamically reconfigure the coupling facility channels that are connected to the operating system partition.

**Note:** With CF duplexing, a CF logical partition can use the coupling facility sender function to communicate with another CF logical partition. That means, you can define sender channel paths (CFS, CBS, ICS) besides the receiver channel paths (CFR, CBR, ICR) in a CF partition or use CF peer channels to communicate between two CF partitions.

---

## Chapter 4. I/O Configuration Definition Process

You specify a configuration to the software at IPL or at dynamic configuration. You specify a configuration to the hardware at POR or at dynamic configuration.

When you dynamically change a configuration, you can change the I/O configuration definitions to both hardware and software or to software only. A software-only change modifies only the software control structures, such as real device blocks (RDEVs). A hardware and software change modifies both the hardware and software control structures. In most cases, you will make simultaneous dynamic configuration changes to both hardware and software configuration definitions.

---

### Defining an I/O Configuration to the Software

Figure 8 shows the process of defining an I/O configuration to the software. At IPL, the system reads an IODF and constructs RDEVs and all device and I/O configuration-related control blocks. When you select and activate a new configuration, the system determines the changes needed to the RDEVs based on comparing the current IODF and the newly selected IODF. More detailed descriptions follow the figure.

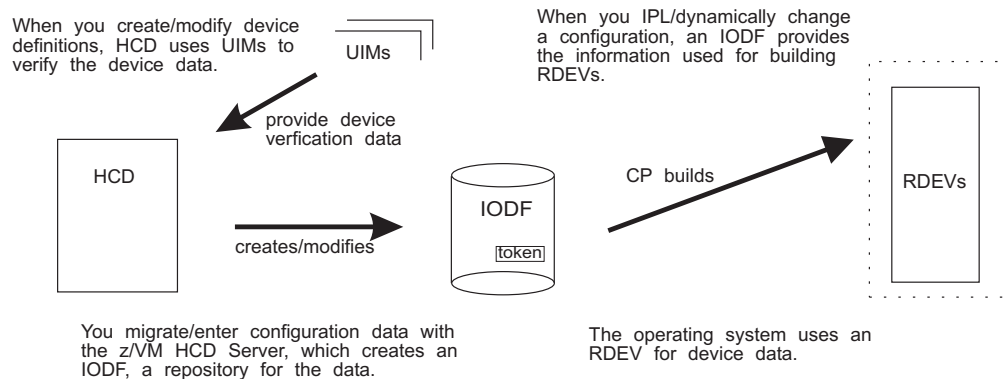

Figure 8. I/O Configuration to the Software

### IODF

You can organize your configuration data in an IODF in multiple ways. For example:

- You can define multiple operating system and processor configurations in one IODF. The configurations can share common device definitions; this reduces the maintenance effort when devices are changed.
- For a processor that supports logical partitions, you can define the configurations for the processor and the operating systems running in the logical partitions of that processor in one IODF.
- From the IODF representing the complete configuration (master IODF), you can create IODFs containing parts of the whole configuration (for example, a processor with all of its relevant operating systems). These IODFs can be distributed to a target system and used for activation.

- You can define several IODFs for the same hardware, with different configurations for use in different circumstances. However, this approach is not recommended, because you might need to update multiple IODFs when you change the configuration. It is recommended to use one IODF for the processors and OS configurations that share devices.

## UIMs

Unit information modules (UIMs) contain the information and rules that HCD uses to process I/O device definitions. When you update an IODF, HCD uses UIMs to validate the device definitions you enter.

UIMs are provided with HCD for devices that z/VM supports. For a non-supported device, you may be able to use a generic UIM or a UIM from a similar IBM device. For information about providing a UIM, see *z/OS MVS Device Validation Support*. To use with z/VM HCD, see “Using UIMs with z/VM HCD,” on page 371.

Through the *Supported Hardware Report*, you can view a list of devices that are supported on your system.

**Note:** The unit-information modules (UIMs) needed for z/OS software-configuration support are not in the z/VM version of HCD. Therefore, you cannot define a z/OS software configuration using HCD on z/VM. If you have a mixed environment with z/VM and z/OS systems on a single server, use HCD on a z/OS system as the central place for I/O configuration definition both for the hardware and for the z/VM and z/OS software definitions. You must then export the resulting production IODF to any other z/OS systems and to the z/VM systems for activation (or, alternatively, for some or all of the z/OS systems, you can share the IODF via shared disk).

## RDEV

A unit control block (RDEV) holds information about an I/O device, such as:

- State information for the device
- Features of the device

---

## Defining an I/O Configuration to the Hardware

Figure 9 on page 21 shows the process of defining an I/O configuration to the hardware. A configuration is defined to hardware when an IOCDS initializes the IOCDS information in the hardware system area (HSA) during a POR. A configuration is also defined to hardware when information in HSA is updated during a dynamic configuration change. More detailed descriptions follow the figure.

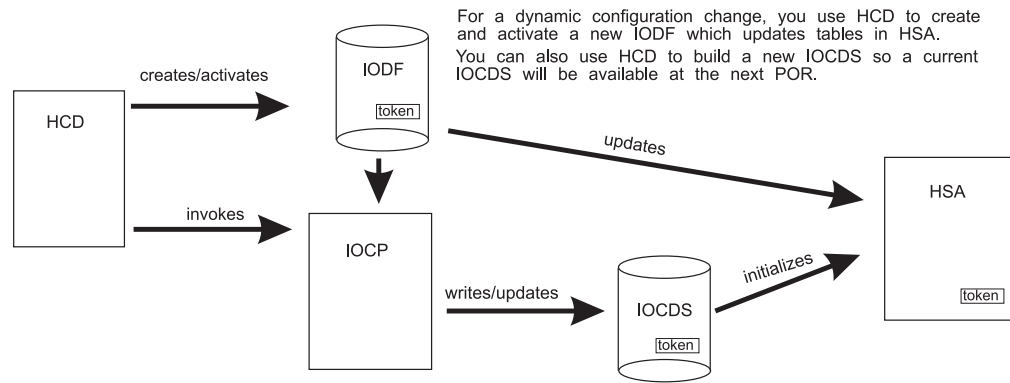

At POR, the system uses information in the IOCDS to create tables in HSA.

Figure 9. I/O Configuration to Hardware

**Note:** HCD uses a worldwide unique token to match the IODF data with the HSA configuration data.

## IOCP

I/O configuration program (IOCP) creates an IOCDS to define a configuration to the channel subsystem at POR. IOCP is shipped on the z/VM tape, and a stand-alone version is available on a processor.

You can specify at any time that you want an IOCDS written for a configuration defined in an IODF. It is a good practice to write an IOCDS when you activate an IODF so a current IOCDS is available for the next POR. HCD invokes IOCP to write an IOCDS. IOCP builds a configuration definition from IODF information and stores the definition in an IOCDS so it is available when a POR is required.

Processors can have multiple I/O configuration data sets. You can specify the one that you want to update.

## IOCDS (Input/Output Configuration Data Set)

An IOCDS contains information to define the I/O configuration to the processor complex's channel subsystem. The IOCDS is built by the IOCP. A POR loads the IOCDS into HSA to initialize the hardware to reflect the IOCDS.

## HSA

The hardware system area (HSA) contains tables that include information about the current configuration.

---

## Ensuring that the Software and Hardware Definitions Match

Before your first dynamic configuration change, you must use HCD to create an IOCDS from the IODF that will be used for a subsequent IPL, then perform a POR using that IOCDS. The POR places information about the hardware configuration in the hardware system area (HSA). The same IODF must be used at IPL to define the software configuration.

To be able to perform a software and hardware dynamic change, your hardware and software definitions must match. When you use the same IODF to define your software and hardware configurations, the software and hardware definitions match.

However, there may be times when you want to change your software definition, for example, to temporarily run a test system. To change your software definition, you might perform a software-only dynamic change using a different IODF. In this case, your software and hardware definitions do not match and you cannot perform a full hardware and software dynamic configuration change.

To be able to make a dynamic hardware and software change, you can perform a software-only change using the IODF that was used to define the current hardware configuration. This IODF is the one used to define the software and hardware configuration at POR or at the last full software and hardware dynamic configuration change.

**Note:** You could also perform a POR and the subsequent IPLs using the IODF with the current software configuration so the software and hardware definitions match.

Of course, the software-only dynamic change does not require an IPL. You just need to remember the IODF that you last used to define the software and hardware configuration so you can use it for the software-only change. This IODF is the one you used for the last POR or the last full software and hardware dynamic change. When you use this IODF for the software-only change, the software and hardware definitions match.

You can also use a token called the processor configuration token to find the IODF. The processor configuration token exists in three places as described in Table 1.

Table 1. Location of Processor Configuration Token

Where the Processor Configuration Token Exists	When the Token Is Placed There	How You Can View the Token There
In a production IODF  There is a processor configuration token for each processor definition.	When you change a processor definition and build a new production IODF, a unique token is placed in the production IODF.	View the token in the Processor Token field on the HCD CSS report.
In an IOCDS	When you build an IOCDS, the unique token is placed in the IOCDS.	View the token from the Hardware Management Console or use HCD.
In HSA	When you POR your processor or activate a dynamic change to the software and hardware, the IOCDS information is used to create tables in HSA. HSA then contains the unique token.	View the token by invoking the HCD function <i>Activate a hardware or software configuration</i> (REXX utility <b>CBDSACT</b> ) with the <b>TEST</b> parameter.

To determine the IODF that you last used for the software and hardware definition, view the token in HSA. Then view the tokens for each processor definition in the production IODFs until you find the IODF with the token that matches the token in HSA.

After you determine the IODF from the last POR or software and hardware dynamic configuration, use that IODF for a software-only change to have the software and hardware configurations match.

**Attention:** If the only IODF matching the hardware configuration in HSA is accidentally deleted, no dynamic changes are possible until after the next POR. For this reason, always keep a backup copy of your current IODF.



---

## Chapter 5. How to Set Up and Customize z/VM HCD

### Overview

This chapter handles the following topics:

- “Setting Up z/VM HCD”
- “Setting Up the z/VM HCD TCP/IP Dispatcher for HCM”
- “Defining an HCD Profile” on page 26

---

### Setting Up z/VM HCD

HCD and HCM for z/VM is pre-installed on the z/VM operating system and therefore installed with the z/VM product. The installation of z/VM is carried out using VMSES/E. For more information, refer to the z/VM installation documentation.

Setting up z/VM HCD requires the following steps:

1. Install z/VM containing the pre-installed z/VM HCD product (see the z/VM installation documentation and the *HCD/HCM for z/VM Program Directory*).
2. Set up the z/VM HCD TCP/IP dispatcher for HCM (see “Setting Up the z/VM HCD TCP/IP Dispatcher for HCM”).
3. Download HCM to the PC and install it (see *z/OS and z/VM: Hardware Configuration Manager User's Guide*).
4. Define your HCD profile (see “Defining an HCD Profile” on page 26).

**Note:** Most of the files needed or generated by z/VM HCD may reside on minidisks as well as in shared file system (SFS). There are only two file types which must be located on a minidisk:

- the IODF file(s) used by z/VM HCD
- the trace file(s) generated by z/VM HCD

---

### Setting Up the z/VM HCD TCP/IP Dispatcher for HCM

With HCD and HCM, z/VM HCD contains two I/O configuration components which work together in a client/server relationship. HCD on z/VM takes over the server role and HCM takes over the client role. Whenever an HCM client program instance needs an HCD instance to perform I/O configuration tasks, a dedicated session between the two instances has to be established. The session lasts for arbitrarily many operations - not only one operation. The communication between HCD and HCM is performed by the z/VM HCD TCP/IP dispatcher for HCM, which serves the following purposes:

1. Wait for incoming connection requests from an HCM client and establish a dedicated session between the HCD client and the HCD server instance. Close the session and clean up if either client or server want to stop the session or an error occurs.
2. Once a session between an HCM client instance and an HCD server instance is established: receive requests from the client instance, forward requests to the server, receive the request results from the server, and send the results back to the client.

You find detailed information on how to set up the z/VM HCD TCP/IP dispatcher for HCM in the *z/OS and z/VM: Hardware Configuration Manager User's Guide*.

---

## Defining an HCD Profile

You can define a profile to tailor the supplied defaults and processing options to your specific installation needs. Using a profile is optional and will remain in effect for the entire session. At initialization time, HCD reads the profile and processes each statement in turn.

The profile statements are contained in a file allocated to the DD name HCDPROF. The following statement, for example, allocates the file to HCDPROF:

```
FILEDEF HCDPROF DISK HCD PROFILE *
```

The file must have the following characteristics:

- Have fixed-length, fixed-blocked record format
- Have 80 character records.

The following rules apply to a profile statement:

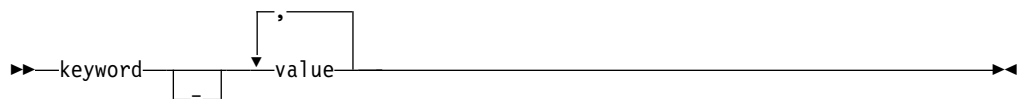

The specifications for a profile statement are as follows:

### **keyword**

Is the name of the keyword. Each keyword starts on a new line.

- = Can be omitted, if the keyword is followed by a blank.

### **value**

Specifies one or more values to be assigned to the keyword.

Use /\* and \*/ as delimiters for comments in a profile statement. An asterisk (\*) in column one can be used for comments as well; a single comment can span several lines. Do not use sequence numbers in your profile.

## Keywords

The following keywords are supported for a profile statement:

### **Extending Allocation Space**

#### *MCF\_EXTENSION*

This HCD profile option lets you extend the allocation data space for MCF data sets to provide space for updates. With this keyword, you specify the percentage of additional space that is to be allocated when defining an MCF data set. Per default, an MCF data set is allocated with 30 percent additional space than actually needed to hold the MCF data. You can use this space for updates that consume data space without the need to allocate a new MCF and delete the old one. For example, `MCF_EXTENSION = 50` allocates 50% additional space.

#### *CHLOG\_EXTENSION*

This HCD profile option lets you define additional space when allocating the change log data set. With this keyword, you specify the percentage of

additional space that is to be allocated when defining a change log data set. By default, a change log data set is allocated with the same size as the associated IODF. For example, a value set to 50 allocates 50% additional space. The default extension is 0.

## Options for Text Reports

### *LINES\_PER\_REPORT\_PAGE*

Specifies the maximum number of lines per page for reports. The default value is 55.

### *UPPERCASE\_ONLY*

YES/NO. Specifies whether all text reports will be written in uppercase or not. This is useful when using printers that do not have the English codepage. The default is NO.

## Layout of HCD Graphical Reports

### *GCR\_SCALE*

Specifies the scaling factor for graphical reports when using BookMaster®. The default is *GCR\_SCALE=.6*.

### *GCR\_COMPACT*

YES/NO. Specifies whether to see more objects in a graphical report. The default is NO. Depending on the report type, a different maximum number of objects is shown on one page:

Report Type	COMPACT=NO	COMPACT=YES
CU	12 channels, 8 control units	16 channels, 10 control units
LCU	8 channels, 8 control units	8 channels, 8 control units
CHPID	8 channels, 64 control units	16 channels, 64 control units
Switch	1 switch	1 switch
CF	1 coupling facility	1 coupling facility

### *GCR\_FORMAT*

Specifies the formatting type:

#### **BOOKIE**

For BookMaster. This is the default.

**DCF** To create a file for DCF containing script commands.

**GML** To create a file for DCF containing GML tags.

### *GCR\_FONT*

Specifies the font to be used for an HCD graphical report; applicable only if *GCR\_FORMAT=DCF* or *GCR\_FORMAT=GML* was specified. Use the appropriate font supported by your installation. For information on how to create a graphical report, see “Create Graphical Configuration Reports” on page 71.

## TRACE Command

### *TRACE*

Activates and deactivates the HCD trace facility. All parameters of the TRACE command are valid except the ID=IODF parameter. You cannot use anything else (for example, no comments and no line numbers) in the same line except the TRACE statement. For information on syntax and description on TRACE command, see “TRACE Command” on page 249.

## Control Unit Type when Migrating IOCP Input Files

### *MAP\_CUTYPE*

Specifies how a control unit type in an IOCP input file is mapped to a control unit type in the IODF. Specify one or more of the following parameters:

`MAP_CUTYPE = xxxxx,yyyy-yy`

`xxxxx`

is the control unit type specified in an IOCP input file

`yyyy-yy`

is the control unit type and model to be used in the IODF.

Example:

`MAP_CUTYPE = 3791,3791L`

`MAP_CUTYPE = 3490,3490-1CA`

## Extended Migration

### *MIGRATE\_EXTENDED*

YES/NO. Specify YES to exploit the extended migration possibilities as described in “Changing I/O Configurations by Editing Files” on page 87.

If you specify NO (which is the default), the additional keywords are not generated during IOCP build and when re-migrating IOCP input files, the migration function ignores the commented \*\$HCDC\$ and \*\$HCD\$ tags.

## Loading an IODF into a Data Space

### *IODF\_DATA\_SPACE*

YES/NO. If you specify YES (which is the default), the IODF is loaded into a data space, thereby removing restrictions on the size of the IODF imposed by address space limitations.

If you specify NO, the IODF is loaded into the user address space.

## Delay Device Regrouping

### *DELAYED\_GROUPING*

YES/NO. If you specify YES, HCD performs any necessary device regrouping after a device group split only when the IODF is closed. This gives a better response time in the HCD dialog for large IODFs.

If you specify NO (which is the default), HCD performs a necessary device regrouping each time when users exit the *I/O Device List*, or, in case the *I/O Device List* was called from either the *Operating System Configuration List* or the *Channel Subsystem List*, when leaving these lists.

## Default Settings for OS Parameters

### *OS\_PARM\_DEFAULT*

This keyword overrides a parameter default value set by the UIM. The value is used as a default on the HCD Define Device Parameters/Features panel. The command structure is:

`OS_PARM_DEFAULT = xxxxxx,yyyyyy`

where:

`xxxxxx` is the parameter keyword

`yyyyyy` is the new parameter default value

The SHARED default value, for example, is NO. It can be changed to YES by specifying the HCD profile option:

```
OS_PARM_DEFAULT = SHARED,YES
```

**Note:** Default values cannot be set differently for different device types. Features, for example EMUL3270, cannot be defaulted using this keyword.

## Extension of the Attachable Device List of a Control Unit

### *CU\_ATTACHABLE\_DEVICE*

This keyword allows the attachable device list of a control unit to be extended to include additional device types. Both the control unit type and the device type must be defined via UIMs. The command structure is:

```
CU_ATTACHABLE_DEVICE = xxxxxx,yyyyyy
```

where:

xxxxxx is the control unit type

yyyyyy is the additional device type

Note that more than one device type can be added to the same control unit type.

Example:

```
CU_ATTACHABLE_DEVICE = RS6K,3174
```

```
CU_ATTACHABLE_DEVICE = RS6K,3274
```

## IODF Checker Automation

### *CHECK\_IODF*

YES/NO. If you specify YES, HCD checks an IODF for consistency and structural correctness whenever the IODF accessed in update mode is being unallocated. This corresponds to the TRACE ID=IODF command and will consume processing time depending on the size of the IODF.

If you specify NO (which is the default), HCD does not check the IODF automatically.

## Automatic Activity Logging

### *CHANGE\_LOG*

YES/NO. Specifies whether you want to activate change logging (YES).

The default is NO. If enabled, and HCD additionally maintains an activity log file for the IODF, then HCD logs all updates applied to the IODF in a change log file, and automatically generates activity log entries for updates on HCD objects, like for example, add, delete, update or connect, disconnect. These entries are proposals and are presented in the HCM **Activity Log** dialog when ending an HCM session or accessing a different IODF. You can modify these entries before leaving the dialog. They are stored in the HCD activity log file.

A change of the value setting for this keyword will not be active until the next start of HCD.

## Show Partition Defaults in IOCP Statements

### *SHOW\_IOCP\_DEFAULTS*

YES/NO. Use this option to write comment lines into the generated IOCP deck which show the partition assignments in effect for those CHPID and IODEVICE statements which make use of the IOCP defaults for the PARTITION and NOTPART values.

Setting this option to YES causes the suppressed PARTITION/NOTPART keywords to be generated as comments prefaced by the tag \*\$DFLT\$\*.

The default is NO.

## Export/import Additional Configuration Objects

### SHOW\_CONFIG\_ALL

YES/NO. Use this option to write additional configuration objects during export of switch configuration statements.

Setting this option to YES causes the **Build I/O configuration data** dialog and batch utility to write configuration statements for unconnected control units and devices in addition to those for switches, if the *Configuration/Switch ID* is specified as \*.

The default is NO.

## Example

The following figure shows a profile with sample data:

```
/* ***START OF SPECIFICATIONS***** */
/*
/*   Module Name -      *-----*
/*                   *   CBDSHPF   *
/*                   *-----*
/*
/*   Descriptive Name - z/VM HCD Sample Profile
/*
/* COPYRIGHT -
/* 5739-A03 (C) COPYRIGHT IBM CORP. - 1991, 2002
/* LICENSED MATERIALS - PROPERTY OF IBM
/* SEE COPYRIGHT INSTRUCTIONS, G120-2083
/*
/* *****
/* add any profile statements below
/*
/* OPTIONS for Default Settings for OS Parameter
/*
OS_PARM_DEFAULT = SHARED,YES /* DEFAULT PARAMETERS
/*
/*
/* OPTIONS for Text Reports
/*
LINES_PER_REPORT_PAGE = 55 /* MAX. NUMBER OF LINES PER PAGE
UPPERCASE_ONLY = NO /* SUPPORT NOT ENGLISH CODE PAGE PRT */
```

Figure 10. Example of a z/VM HCD Profile

---

## Chapter 6. How to Work with I/O Definition Files

When you start an HCD session, you need to specify the IODF that HCD is to use. How to do this, how to change to another IODF, and how to use HCD tasks to maintain your IODFs is described below.

Before you can activate your configuration, you must create a work IODF and from this you must build a production IODF. These tasks are described in “Create and Initialize an IODF” on page 35 and “Build a Production IODF” on page 45.

---

### IODF and Activity Log Naming Conventions

The name of an IODF is given by the file identifier of the CMS file. z/VM HCD requires a certain naming convention in order to identify IODFs and accompanying files.

The CMS *file name* of an IODF must be IODFxx, where xx are two hexadecimal digits.

The CMS *file type* is:

**WORKIODF**

for a work IODF

**PRODIODF**

for a production IODF

**BACKIODF**

for a backup IODF, which can either be a work IODF or a production IODF

Examples:

```
IODF01 WORKIODF A
IODF01 PRODIODF A
```

If the IODF is MCF-enabled, the CMS file name of the corresponding master configuration file (MCF) consists of the CMS file name of the IODF and one of the following file types:

**WORKMCF**

for the master configuration file of a work IODF

**PRODMCF**

for the master configuration file of a production IODF

**BACKMCF**

for the master configuration file of a backup IODF

The file ID of the corresponding activity log consists of the CMS *file name* of the IODF and one of the following *file types*:

**WORKACTL**

for the activity log file of a work IODF

**PRODACTL**

for the activity log file of a production IODF

**BACKACTL**

for the activity log file of a backup IODF

**WORKCLOG**

change log file for automatic activity logging

**Note:** Using the *CBDSIODF* REXX utility, IODFs are always allocated with filemode suffix 6, because HCD needs the 'update\_in\_place' option on these files. Any other suffix is ignored.

Note, also, that IODF files must reside on a minidisk that is formatted with a block size of 4K.

---

## Deciding on the Number of IODFs

The decision whether to create one IODF for each processor, or to combine the I/O definitions for two or more processors in a single IODF, depends on your environment. This section explains when it is advantageous or even necessary to keep the I/O definitions of two or more processors in the same IODF.

**Shared control units and devices**

If control units and devices are shared by different processors, the I/O definitions for these processors should be kept in the same IODF to keep change effort to a minimum and to avoid conflicting definitions.

**Processor and related OS configuration(s)**

For a full dynamic reconfiguration, the IPLed OS configuration must be in the same production IODF as the processor configuration selected for POR.

**Coupling facility support**

For coupling facility support, you have to maintain your coupling facility definitions for the processors to be connected in the same IODF.

**Switch connections**

It is recommended that you maintain your switch configurations in the same IODF as the hardware and software configuration definitions to provide complete validation of the data path.

In order to lookup the port connections of a switch, all connected objects to the ports of a switch have to be defined in the same IODF.

**CTC connection report**

All CTC connections listed in a CTC connection report must be defined in the same IODF. Misconfigurations can be detected only within the scope of one IODF.

See "Restrictions Applying to the CTC Connection List" on page 70.

**Reporting**

The scope of the reports (textual or graphical) is a single IODF. All I/O definitions required for a report must be kept in the same IODF.

**Validation**

The scope of the validation function is a single IODF.

**HCM** The scope of the configuration shown by HCM is a single IODF.

These requirements and recommendations may lead to a large IODF, depending on the size of the installation. The number of elements in the single IODF may be too large for effective management. HCD provides the possibility of creating manageable *subset IODFs* with a scope limited to a part of the I/O configuration

from a *master IODF* describing the entire configuration. For details on this IODF management strategy refer to “The Master IODF Concept.”

---

## The Master IODF Concept

In order to take full advantage of the available HCD functions and to keep a maximum of freedom for reconfigurations it is proposed to keep a master IODF. A master IODF may contain the I/O definitions for an entire enterprise structure. However, a user may decide to divide the I/O configuration definitions of the whole enterprise into several master IODFs, where little or no interference is expected.

Major configuration changes are done in the master IODF. These include:

- processor configurations,
- OS configurations,
- switch configurations, and
- definitions spanning multiple configurations, for example coupling facility connections or CTC connections.

After such changes have been made, a production IODF is built. From this IODF comprehensive reports can be obtained.

HCD provides a set of functions which allows the management of very large IODFs for their activation on individual systems, like POR, IPL or dynamic I/O changes. Using these functions, subset IODFs containing I/O definitions relevant to only one particular system may be built from the master IODF .

There are no strict rules about what a subset IODF must consist of. Typically it contains a processor configuration with its related OS configuration.

The subset IODF is transferred to the corresponding target system where it is imported and used as the IODF for that system. A subset IODF constitutes a fully functional IODF. When it is built from a master IODF, the processor tokens are preserved. If necessary, updates concerning the target system alone may be carried out using the subset IODF. Subsequently, the subset IODF can be sent back to the system administering the master IODF and merged back into the master IODF, thereby updating it with the changes made at the target system.

The following chart illustrates the possible flow of I/O information according to the master IODF concept.

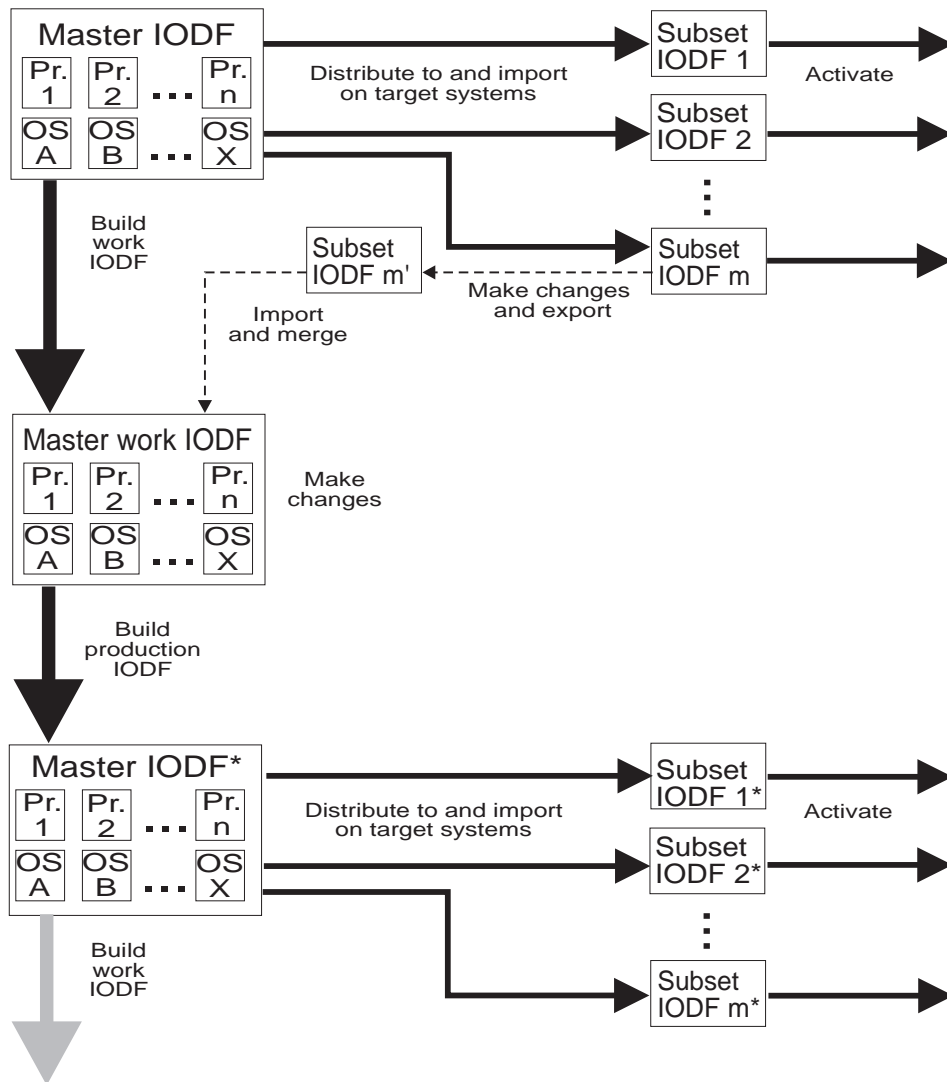

Figure 11. IODF Distribution/Merge Process

## Maintain IODFs

z/VM HCD allows you to perform required tasks on an IODF, which are described in the following subsections. For each of these tasks, either HCM provides analogous functions in its graphical interface or from your z/VM system, you can use a REXX utility. For some tasks, both methods are offered.

You can use the graphical interface of HCM to build your configuration, namely a work configuration as well as a production configuration, according to work and production IODFs. From such a work configuration, with HCM you can automatically generate a work IODF on the z/VM host (see *z/OS and z/VM: Hardware Configuration Manager User's Guide*, section *Relation of Configuration Files and IODFs*).

## Create and Initialize an IODF

HCD stores the I/O configuration data you defined in an IODF. HCD creates an IODF in a certain format and always with filemode suffix 6.

You can use HCM to create a new work IODF. Note that IODF files must reside on a minidisk that is formatted with a block size of 4K.

Also, a REXX utility called *CBDSIODF* is provided for this task which lets you create and initialize a new work IODF (*iodfname* WORKIODF).

For information on how to invoke the REXX utility on the host, refer to “Create and Initialize an IODF (CBDSIODF)” on page 123.

## Delete an IODF

It is recommended to perform this task using HCM (see *z/OS and z/VM: Hardware Configuration Manager User's Guide*). If an activity log is associated with the IODF, it is also deleted. Also, if an HCM master configuration file (MCF) is associated with the IODF, it is deleted along with the IODF.

Since an IODF is a CMS file, you can also delete it via the CMS **ERASE** command. (See *z/VM: CMS Commands and Utilities Reference* for more information.) However, an associated activity log is not automatically deleted in this case.

## Copy an IODF

With this function, you can enlarge the size of an IODF while copying the source IODF to a larger target IODF. This is helpful if your original IODF has reached its limit.

You can use HCM to perform this task. If the IODF has an activity log, that log may also be copied. Also, if an HCM master configuration file (MCF) is associated with the IODF, it is copied along with the IODF.

Also, a REXX utility called *CBDSCOPY* is provided for this task which copies the contents of the IODF. For information on how to invoke the REXX utility on the host, refer to “Copy IODF (CBDSCOPY)” on page 143.

## Build Production IODF

After you complete the input of your configuration data, you have to build a production IODF from the work IODF. The production IODF is used by the operating system to build the configuration data at IPL time. This active production IODF is used for building the IOCDs.

You can use HCM to perform this task.

Also, a REXX utility called *CBDSPROD* is provided for this task which lets you build a production IODF from a work IODF. After the production IODF has been built, the work IODF can be used for further updates, because the processor token is refreshed in the work IODF.

For information on how to invoke the REXX utility on the host, refer to “Build a Production IODF (CBDSPROD)” on page 133.

## Activate a Configuration

You can dynamically make changes to a running configuration. That is, the possibility is offered to change from a currently active configuration to some other configuration that is to be made active without the need to POR or IPL the system again.

A REXX utility called *CBDSACT* is provided for this task.

For information on how to invoke this REXX utility on the host, refer to “Activate a Configuration (CBDSACT)” on page 163.

## Build a Work IODF from a Production IODF

z/VM HCD allows you to perform all tasks on the data stored in a production IODF as long as you do not try to change it.

If for some reason you decide to change a production IODF, you first have to convert the production IODF back into a work IODF.

You can use HCM to perform this task.

Also, a REXX utility *CBDSWORK* is provided which lets you generate a work IODF from a production IODF.

For information on how to invoke this REXX utility on the host, refer to “Build a Work IODF from a Production IODF (CBDSWORK)” on page 135.

When you have completed the changes, you can use HCM or use REXX utility *CBDSPROD* to build a new production IODF from the work IODF.

## Compare IODFs or CSS/OS Configurations

You may want to compare two IODFs and have the differences reported.

A REXX utility called *CBDSCOMP* is provided that allows you to compare configurations in IODFs. With a parameter, you can control whether you want to compare IODFs or CSS/OS configurations.

For information on how to invoke this REXX utility on the host, refer to “IODFs or CSS/OS Compare Reports (CBDSCOMP)” on page 151.

## View a Configuration

You can display a graphical view of a configuration on your workstation. In a proprietary configuration file, HCM maintains the physical configuration data as a diagram in sync with the IODF on the z/VM host. Together, the IODF and the HCM configuration file form a single data repository, from which HCM creates a visual representation of the configuration.

You perform this task using HCM (see *z/OS and z/VM: Hardware Configuration Manager User's Guide*).

## Export an IODF

You can send a (work or production) IODF and, optionally, its activity log to another (local or remote) system. The transport is done over the RSCS network. The function can be started with a REXX utility (*CBDSEXP*, see “Export an IODF

(*CBDSIMP*)” on page 160). You must receive the exported IODF at the target system via another REXX utility (*CBDSIMP*, see “Import an IODF (*CBDSIMP*)” on page 158 or “Import an IODF”).

## Import an IODF

You need to receive (import) an exported IODF at the target system. For this purpose, z/VM HCD provides a REXX utility called *CBDSIMP* which is further described in “Import an IODF (*CBDSIMP*)” on page 158.

## Print and Draw Configuration Reports

With HCD, you can print and draw logical views of a configuration.

The REXX utility *CBDSDRAW* allows you to produce a graphical representation of the I/O configuration based on the logical definitions in the IODF. For information on how to invoke this REXX utility, refer to “Create a Graphical Configuration Report (*CBDSDRAW*)” on page 148.

You can also produce a textual report from an IODF using the REXX utility *CBDSREP*. For information on how to invoke this REXX utility, refer to “Print Configuration Reports (*CBDSREP*)” on page 145.

**Note:** The HCD reports show the logical views of configurations whereas HCM reports show their physical views.

---

## Activity Logging

You can enable an activity log for each IODF when it is first defined. When you are finished with updating an IODF, that means, finished with updating a configuration with the interactive interface of HCM and you use the **Close** or **Exit** command, HCM will open a dialog if activity logging is enabled for the current IODF. You can add a comment describing the activities you just performed on the IODF. This text will be added to the activity log.

You can view the activity log on the z/VM host using a file editor or browser.

When the IODF is deleted within HCM, the activity log file will also be deleted. When the IODF is deleted via the **ERASE** command, the associated activity log file is not automatically erased.

For information on file naming conventions for activity logs see “IODF and Activity Log Naming Conventions” on page 31.

You can enable automatic activity logging by entering the following keyword into the HCD profile:

```
CHANGE_LOG = YES
```

With this setting, HCD generates automatic entries into the HCM Activity Log dialog when ending an HCM session or accessing a different IODF activity log. These entries describe the updates on HCD objects, like for example, add, delete, or connect, disconnect. You can modify these entries before leaving the dialog. They are stored in the HCD activity log file.

## Rules for Activity Logging

HCD applies the following rules during activity logging:

- When creating an object with immediate updates without leaving HCD, HCD only creates an *'add object'* log entry in the activity log.
- When updating the same object multiple times during one HCD session, HCD creates only one *update object* entry.
- Consecutive IDs (for example for channel subsystems, channel paths, control units or devices) are marked with a 'quantity' number in parenthesis behind the starting ID.
- When repeating an object into a new IODF, no entry is created in the target IODF since this IODF is not accessed by the user.

## Actions Performed on IODFs and Related Activity and Change Log Files

- When you delete an IODF, HCD also deletes the related activity and change log files.
- When you copy an IODF, HCD also copies the activity log file with all its contents. However, HCD does not copy the change log file. Instead, a new change log file is created for the new IODF.
- When you build a production IODF, HCD copies the activity log file but *not* the change log file.

---

## The New IODF Version 5 Format

IODF versions up through z/VM V5.1 (the V4 format) contained a separate device definition record for each single device. To reduce the size of IODFs and to improve the processing performance of large configurations, starting with z/VM V5.2, HCD uses the new IODF V5 format, arranging single devices into a device group, if they have the following characteristics in common:

IODF versions up through z/VM V5.1 (the V4 format) contained a separate device definition record for each single device. To reduce the size of IODFs and to improve the processing performance of large configurations, starting with z/VM V5.2, HCD uses the new IODF V5 format, arranging single devices into a device group, if they have the following characteristics in common:

- The device numbers of all devices are in consecutive sequence.
- All devices of the group have the same device type (unit, model) and attribute values (Serial-#, Description, VOLSER).
- All devices of the group are attached to the same control unit(s).
- All devices of the group are connected to the same processors/channel subsystems and have the same corresponding processor-specific attributes.
- All devices of the group are connected to the same operating systems and have the same corresponding OS-specific attributes (device type, parameters, features, console definition, subchannel set number).

Devices that adhere to these rules are aggregated into device groups containing the maximum number of applicable devices. If you apply a change on one or more devices from a group, HCD checks how to rearrange the devices and device groups contained in the IODF in order to achieve the best possible organization of devices into groups again according to the specified rules. Another example may be that you change the attributes of a group in a way that two previously similar groups must now be merged into one group. However, the required rearrangements are not necessarily performed by HCD at once, but may be delayed to an appropriate point in time.

z/VM V5.2 HCD or later releases can access an IODF from pre-V5.2 HCD releases and can perform view/read functions (for example, copy, activate) without permanently upgrading the IODF. However when you try to change the configuration contained in a lower version IODF, upgrading is required before the change. A message will inform you about the necessity of a permanent upgrade. Use HCM to upgrade from previous IODF versions to a V5 IODF.

Earlier HCD releases provide limited read access to V5 IODFs. There is a coexistence support for V5 IODFs on back-level z/VM releases for read-only functions like the ACTIVATE function. You need to install the corresponding PTF, and you must have z/VM 5.1 HCD running on your system.

An IODF upgrade function is available in HCM to migrate your IODF from version 4 to version 5. See *z/OS and z/VM: Hardware Configuration Manager User's Guide*.

Also, note that the Copy IODF (CBDSCOPY) function will always create the target IODF in the newest version. See "Copy IODF (CBDSCOPY)" on page 143.

## Coexistence Overview of Functionality Based on IODF Version

If you plan to share an IODF among multiple z/VM systems that are at different release levels, you have to consider several restrictions concerning IPL, IODF usage, and dynamic reconfiguration.

Table 2 summarizes the available functionality on z/VM releases based on the IODF level.

Table 2. IODF Compatibility Overview

	System running z/VM V5R2 and future releases	System running z/VM V4R4 to V5R1
<b>IODF created with z/VM V5R2 or later (Version 5 IODF)</b>	<ul style="list-style-type: none"> <li>No restriction to HCD use (read/update)</li> <li>IPL</li> <li>Dynamic Activate</li> </ul>	<p><u>Compatibility SPE installed (APAR VM63721, PTF UM90231):</u></p> <ul style="list-style-type: none"> <li>Only read / no update in HCD</li> <li>IPL</li> <li>Dynamic Activate</li> </ul> <p><u>Compatibility SPE not installed:</u></p> <ul style="list-style-type: none"> <li>No access possible in HCD</li> <li>No IPL</li> <li>No Dynamic Activate</li> </ul>
<b>IODF created with z/VM pre-V5R2 (Version 4 IODF)</b>	<ul style="list-style-type: none"> <li>Read access possible w/o upgrade</li> <li>Update access requires IODF upgrade</li> <li>IPL</li> <li>Dynamic Activate</li> </ul>	<ul style="list-style-type: none"> <li>No restriction to HCD use (read/update)</li> <li>IPL</li> <li>Dynamic Activate</li> </ul>

Note that if the IODF contains processor configurations with hardware definitions that are not known to the corresponding z/VM release, you must use a z/VM release that has the corresponding support installed.



---

## Chapter 7. How to Work with Switches

With the introduction of the ESCON architecture and its supporting hardware, ESCON Directors (switches) became an integral part of the configuration. With the FICON architecture, FC switches are supported.

You can define switches, switch connections and how the switches are physically cabled. A switch configuration, also called port matrix, defines how the various ports of the switch connect to each other. For example, the switch configuration defines whether a port is blocked, has a dedicated connection to another port, or whether dynamic connections to other ports are allowed or prohibited. In other words, the switch configuration defines the inside of a switch.

---

### Possibilities of Switch Connections

ESCON Directors enable either dynamic connections or dedicated connections. FC switches allow only the definition of dynamic connections.

HCD supports fabrics containing cascade switching using FICON switches. Such a fabric consists of two or more FICON switches.

**Note:** Other than for chained ESCON switches where the dynamic switch for a channel path specifies the switch containing the port address that is used as link address, in the FICON case the dynamic switch ID is always the channel path entry switch.

The following four figures (Figure 12 on page 42 through Figure 15 on page 43) illustrate the path types of switch connections for ESCON switches or fiber channel (FC) switches. ESCON switches support the configuration shown in figures Figure 12 on page 42 through Figure 14 on page 43. For FC switches, only the first and the fourth configuration type shown in Figure 12 on page 42 and Figure 15 on page 43 is supported.

Figure 12 on page 42 shows a configuration with a single switch; the entry switch is the dynamic switch. (The dynamic switch in HCD corresponds to the SWITCH keyword of the CHPID macroinstruction from the IOCP point of view.)

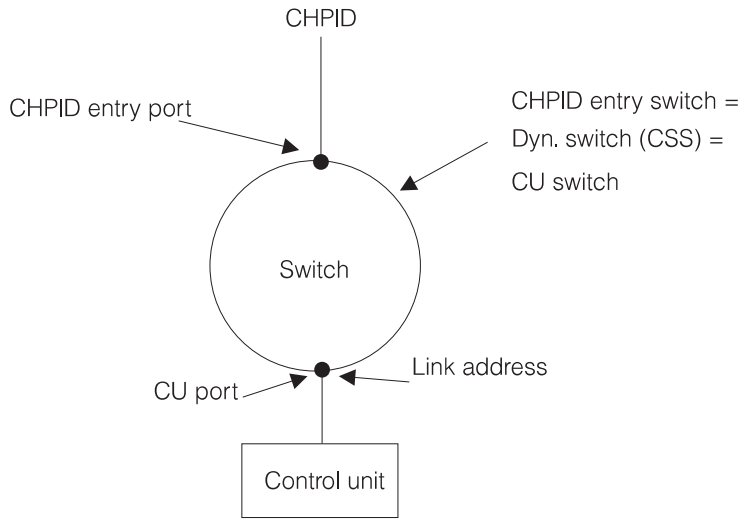

Figure 12. Example of a Configuration with One Switch

Figure 13 shows a configuration with two switches, where the entry switch is different from the dynamic switch. (The two switches are chained and the entry switch for the channel path has a dedicated connection.)

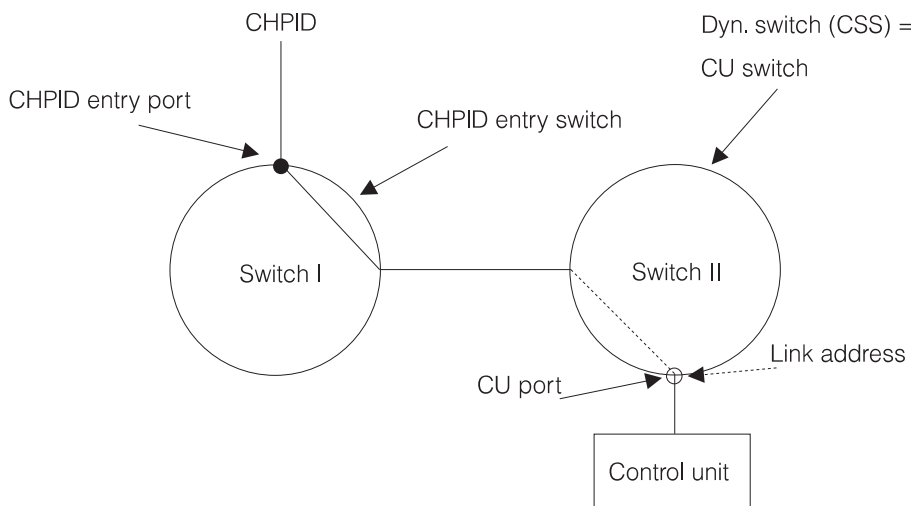

Figure 13. Example of a Configuration with Two Switches (1)

Figure 14 on page 43 shows a configuration with two switches, where the entry switch is the same as the dynamic switch. (The two switches are chained and the CU switch has a dedicated connection.)

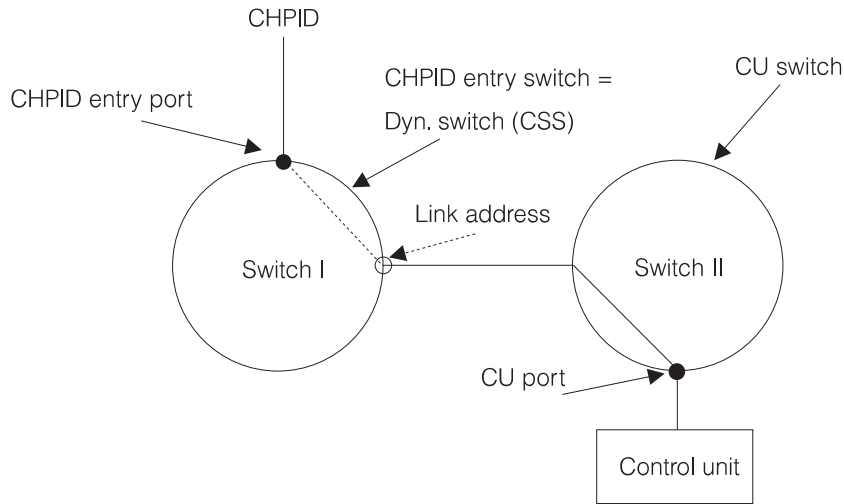

Figure 14. Example of a Configuration with Two Switches (2)

Figure 15 shows a configuration with cascading switches. The fabric in this figure contains two cascading FICON switches. The link address 5904 specifies 59 as switch address and 04 as port address.

**Note:** The switch address is unique within a fabric, but may occur also in other cascaded switch fabrics. However, as HCD has no knowledge of which switches are within the same fabric, it is highly recommended to assign unique switch addresses across fabrics.

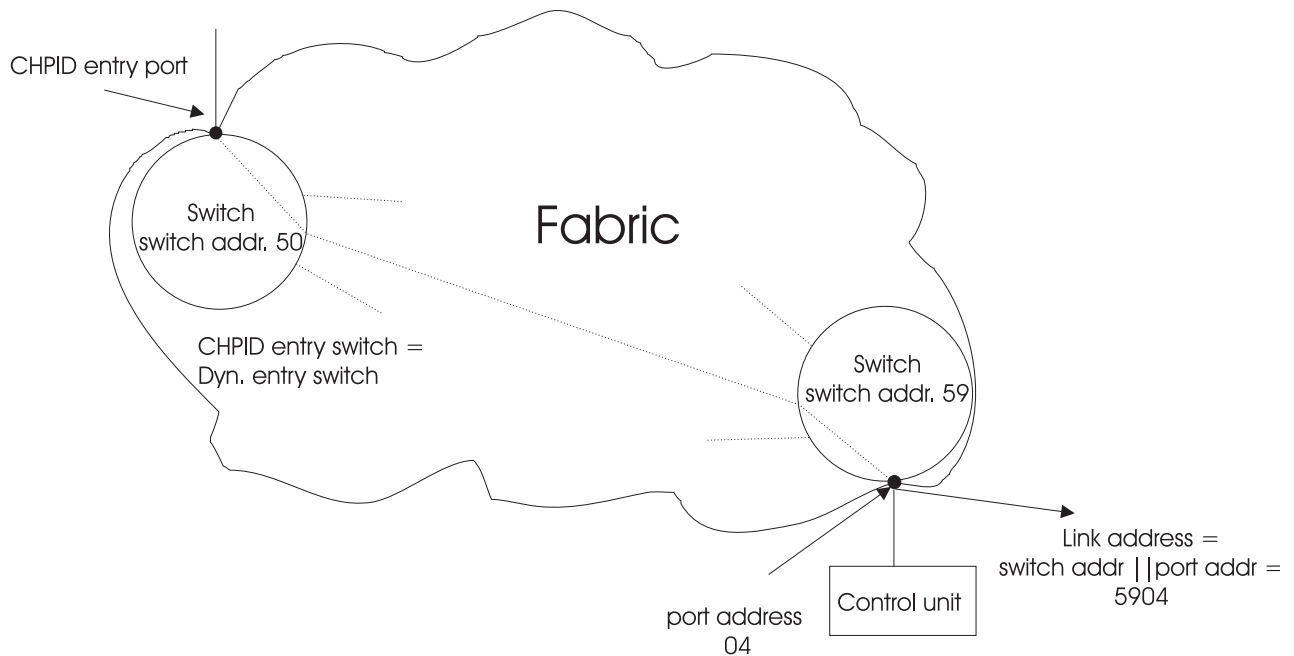

Figure 15. Example of a Configuration with Cascading Switching

---

## Advantages of Switch Definitions with HCD

You have the following advantages when you define switches with HCD:

- More rigorous validation of the configuration definition.

If all switches between the channels and control units are defined, HCD can determine whether a valid path exists between the processor and control unit. For example, HCD can validate that the destination link address specified for a channel path is a valid port on the dynamic switch.

- The possibility to define several switch configurations for each switch.
- Graphical configuration reports include switch connections.

---

## Chapter 8. How to Activate or Process Configuration Data

Before the channel subsystem and the operating system can use the configuration that you have defined with z/VM HCD, you must build a production IODF from the work IODF.

With the production IODF, you can perform the following tasks in preparation for POR/IPL or for performing dynamic activation:

- Build an input/output configuration data set (IOCDS) from the production IODF for a specific processor. The configuration can then be used by the channel subsystem.
- Build an input file for the input/output configuration program (IOCP).
- Activate the configuration dynamically using the activate function.
- Switch the IOCDS for the next POR
- Specify in the SYSTEM CONFIG file of z/VM which IODF and which z/VM configuration is to be used for IPL.

---

### Build a Production IODF

Although z/VM HCD validates configuration data as it is entered, a complete validation may not be performed, because some other required data may not be defined at this time. Therefore, a "post-validation" is performed at "Build Production IODF" time. This validation might issue messages you have to deal with, according to their severity. The production IODF is not created if any errors with a severity higher than 'warning' are produced.

Depending on what is defined in the configuration, the work IODF must contain a definition for at least one operating system *or* one processor *or* one switch.

- For a VM operating system, the IODF must contain at least one device.
- For a processor, the IODF must contain a definition for at least one channel path, one control unit, and one device. If only receiving CF channel paths are defined for a processor, the control unit and device definitions can be omitted.

Prior to building the production or validated work IODF, HCD updates the work IODF. For processors that must be defined for a maximum HSA, it extends the processor configuration to its maximum. This means that HCD ensures that all logical channel subsystems as well as all partitions are defined for the processor, and that each channel subsystem allows for the maximum number of devices per subchannel set.

It's possible that a work IODF will satisfy all validation rules, but that a contained processor configuration supporting multiple logical channel subsystems (in the following called XMP processor processor) will be lacking at least one physical channel identifier (PCHID). In this case, the output from *Build Production IODF* will be a *validated work IODF*, but a message will show all CHPIDs for which the required PCHIDs are missing. Before you can build the final production IODF for the XMP processor, you must insert all PCHIDs into that validated work IODF.

With a validated work IODF, you can use the CHPID Mapping Tool to insert all required PCHIDs. Input to this tool is an IOCP input file. To create this input, use the REXX utility *CBDSIOCP* (*Build an IOCDS or an IOCP Input File*). The IOCP

input file is suitable for use with the CHPID Mapping Tool. This tool eases the task of mapping CHPIDs to PCHIDs in an IODF. See “How to interact with the CHPID Mapping Tool” on page 49 for more detailed information on how to interact with the CHPID Mapping Tool to insert the missing PCHIDs into the validated work IODF. As soon as all PCHIDs are inserted into the validated work IODF, the production IODF can be built.

You can build a production IODF using HCM. Also, the REXX utility *CBDSPROD* allows generation of a production IODF from a work IODF. For more information on invoking this utility, see “Build a Production IODF (CBDSPROD)” on page 133.

---

## Build an IOCDS or IOCP Input File

When a production IODF has been created, you can build an IOCDS (it can be built only from a production IODF). Processors may have varying numbers of IOCDSs. A particular IOCDS is used at POR time to make the configuration data known to the CSS.

The REXX utility *CBDSIOCP* allows to perform an IOCDS download or to build an IOCP input file from a processor configuration defined in a production IODF. How to invoke this utility is described in “Build an IOCDS or an IOCP Input File (CBDSIOCP)” on page 137.

### Note:

1. Unlike writing an IOCDS using the IOCP program, the HCD process generates no IOCP report when using the *Build IOCDS* function. HCD maintains an IOCDS status record in the IODF which keeps track of the last IOCDS update performed on a processor.
2. When a processor has been upgraded in the IODF, the old IOCDS status data in the IODF is deleted.

## Build an IOCP Input File

Sometimes it is necessary to build an IOCP input file (only possible from a production IODF):

- If you have to use the stand-alone IOCP program, which does not support direct access to the production IODF.
- If you want to create a backup on tape in case you need to recover the contents of the IOCDS in the service processor.
- If you need an IOCP file as input to the CHPID Mapping Tool to map PCHIDs for XPM processors.
- If you need an IOCP input file for a processor on which there is no HCD running (e.g. a new processor). Also, if you upgrade a processor to a model that results in a new IOCP SYSTEM value and the processor does not support an IOCDS write in preparation for a processor upgrade, you have to run the stand-alone IOCP program.

### IOCP Input Files Using Extended Migration

As described in “Updating Parts of a Configuration by Migrating Input Files” on page 106, HCD introduces an extended migration to allow you to define your complete logical configuration without using HCM.

The extended migration allows you to, for example, define a switch with its ports or define serial numbers and descriptions for devices and control units by editing your input files and migrating them into HCD.

Analogously, when building an IOCP input file from an IODF, information is generated that describes the additional parameters of the configuration objects (if the prerequisites under “Prerequisites to Exploit the Extended Migration” are met). Within the generated IOCP input file, the additional parameters and control statements are shown as comments with special HCD tags so that they can be processed by the IOCP program. When re-migrating such an IOCP input file to HCD, the tagged comments are identified by HCD and migrated correspondingly.

If you want to use the input file for both, IOCP processing and HCD migration, the new records must apply to the following rules, so that they can be processed by both programs:

- The new parameters start with the string `*$HCDC$` in column 1.
- The new SWITCH statement starts with the string `*$HCD$` in column 1.
- The IOCP control statement does not have any comment.
- The additional HCD tagged records follow immediately the last record of the corresponding IOCP control statement.
- The first keyword starts at column 16.
- The last operand is not followed by a comma.
- There is no comment to the right of the operand.

**Prerequisites to Exploit the Extended Migration:** To generate the additional keywords during IOCP file build, note the following prerequisites:

- Specify the following entry in the HCD profile:  
`MIGRATE_EXTENDED = YES`

When you specify `MIGRATE_EXTENDED = NO` (which is default), the additional keywords are not generated during IOCP build. In addition, when remigrating the IOCP input files, the migration function ignores the commented `'*$HCDC$'` and `'*$HCD$'` tags.

The HCD profile is explained in “Defining an HCD Profile” on page 26.

- When building IOCP input files, you have to set parameter **NOSA** in the input parameter string for the related HCD function.

**Example of an IOCP Input File:** Figure 16 on page 48 shows you an example of a generated IOCP input data set with the new parameters. Note that each new parameter starts with an `*$HCDC$` in column 1. The new switch control statement starts with `*$HCD$` in column 1.

```

ID      MSG1='EXAMPLE',MSG2='BOKA.IODF03 - 95-07-21 16:00',      *
      TOK=('TWO',0000000190009672160057040095202F00000000,0000*
      0000,'95-07-21','16:00:57','BOKA','IODF03')
*$HCDC$      DESC='Cluster(099) test floor'
*$HCDC$      SERIAL='1044009672'
*$HCDC$      SNAADDR=(USIBMSC,TWO)
RESOURCE PARTITION=((CF001,3),(MVSSMAL,2),(PRIME,1))
*$HCDC$      DESCL=('Coupling facility','MVS 5.2.0 System1','Producti*
      on CF image')
CHPID PATH=(10),PARTITION=((CF001),(CF001)),TYPE=CFR
*$HCDC$      DESC='Receiver'
CHPID PATH=(13),PARTITION=((PRIME),(PRIME)),TYPE=CFS
*$HCDC$      TPATH=(TWO,10,FFFE,FFFE)
*$HCDC$      DESC='Sender'
CHPID PATH=(20),PARTITION=((MVSSMAL),(MVSSMAL)),SWITCH=AB,      *
      TYPE=CNC
*$HCDC$      SWPORT=((AA,C0))
*$HCDC$      DESC='Channel for DASD'
CHPID PATH=(21),PARTITION=((MVSSMAL),(MVSSMAL)),TYPE=CNC
*$HCDC$      DESC='Channel for DASD'
CHPID PATH=(25),PARTITION=((PRIME),(PRIME)),TYPE=CNC
*$HCDC$      SWPORT=((AB,80))
*$HCDC$      DESC='Switch connection'
CHPID PATH=(26),PARTITION=((MVSSMAL),(MVSSMAL)),TYPE=CNC
*$HCDC$      SWPORT=((AA,C5))
*$HCDC$      DESC='Switch connection'
CNTLUNIT CUNUMBR=0005,PATH=(25),UNITADD=((00,001)),UNIT=9032-3
*$HCDC$      SWPORT=((AB,FE))
*$HCDC$      SERIAL='1021-CU511'
*$HCDC$      DESC='SWITCH AB'
CNTLUNIT CUNUMBR=0006,PATH=(26),UNITADD=((00,001)),UNIT=9033
*$HCDC$      SWPORT=((AA,FE))
*$HCDC$      SERIAL='1021-CU510'
*$HCDC$      DESC='SWITCH AA'
CNTLUNIT CUNUMBR=000F,PATH=(20,21),UNITADD=((08,008)),      *
      LINK=(A1,A2),CUADD=3,UNIT=3995-151
*$HCDC$      SWPORT=((AA,C3),(AB,82))
*$HCDC$      SERIAL='5512003330'
*$HCDC$      DESC='DASD on Q4-B3'
CNTLUNIT CUNUMBR=FFFE,PATH=(13),UNIT=CFS
      IODEVICE ADDRESS=(080,004),MODEL=151,UNITADD=08,      *
      CUNUMBR=(000F),STADET=Y,UNIT=3995
      IODEVICE ADDRESS=110,MODEL=3,UNITADD=00,CUNUMBR=(0005),      *
      STADET=Y,UNIT=9032
*$HCDC$      SERIAL='1021-CU511'
*$HCDC$      DESC='SWITCH AB'
      IODEVICE ADDRESS=120,UNITADD=00,CUNUMBR=(0006),STADET=Y,      *
      UNIT=9033
*$HCDC$      SERIAL='1021-CU510'
*$HCDC$      DESC='SWITCH AA'
      IODEVICE ADDRESS=(FFFE,002),CUNUMBR=(FFFE),UNIT=CFS
*$HCDC$      SWITCH SWID=AA,SERIAL='1021-CU510',DESC='SWITCH AA',      *
      PORT=((C0,CE),(FE,FE)),SWPORT=((CA,AB,C6)),UNIT=9033
*$HCDC$      SWITCH SWID=AB,SERIAL='1021-CU511',DESC='SWITCH AB',      *
      PORT=((80,F0),(FE,FE)),SWPORT=((C6,AA,CA)),MODEL=3,      *
      UNIT=9032

```

Figure 16. Example of Input File for Migration Enhancements

## Using the IOCP File as Input for the CHPID Mapping Tool

HCD will allow the generation of an IOCP deck that does not contain any or all necessary PCHID values. You can use this IOCP deck as input to the CHPID Mapping Tool in order to have PCHIDs inserted or updated. The CHPID Mapping

Tool then generates a new IOCP input deck containing the assigned PCHID values. You can then migrate the updated PCHIDs into a validated work IODF. (For more information, see “How to interact with the CHPID Mapping Tool”).

---

## How to interact with the CHPID Mapping Tool

Before you can successfully build a production IODF, correct PCHIDs are required in the configuration for XMP processors. The task of adding or updating required PCHID information for a work IODF for XMP processors is eased by an interaction between HCD and the CHPID Mapping Tool (CMT). A prerequisite for this task is a *validated work IODF*. If you try to build a production IODF from a work IODF where XMP processors are defined, this is only successful if all logical channels (CHPIDs) of all XMP processors have PCHID values defined. If at least one PCHID value is missing, HCM and HCD do not build a production IODF, but nevertheless flag the work IODF as validated.

You can download the CHPID Mapping Tool from the IBM Resource Link™:

[www.ibm.com/servers/resourcelink](http://www.ibm.com/servers/resourcelink)

### Process overview

HCM provides a utility to update the PCHID values via invocation of the CHPID Mapping Tool. The following process describes how you can use HCD (without the need to use HCM) to update the PCHID values assigned by the CHPID Mapping Tool.

Input to the CMT is the hardware configuration file (CFReport<sup>1</sup>) of your machine and a valid IOCP input file (with missing or obsolete PCHIDs).

Output from the CMT is again an IOCP input file that now has all missing or updated PCHID values filled in. Upload this IOCP input file and reimport it into the validated work IODF using the the REXX utility **CBDSMIGR**.

Via this migration task, it is possible to update a validated work IODF with the PCHID values that have been written by the CMT into the IOCP input file. Other changes on the validated work IODF are not possible without losing the status of a validated work IODF. A PCHID migration is only possible to a validated work IODF. All functions that allow read-access to a work IODF are also possible for a validated work IODF. Activate functions are not possible, except for building an IOCP deck that can be used as input to the CMT. Only after all PCHIDs have been inserted into the validated work IODF can you then successfully build a production IODF.

### How to insert or update PCHIDs

Here are the detailed steps you need to perform to insert or update PCHIDs in a validated work IODF.

1. Create a validated work IODF. If your original work IODF satisfies all validation rules for correctness and completion, it is flagged as a validated work IODF when building a production IODF. Your validated work IODF may

---

1. When a machine is ordered, the output of the order process is a binary file that represents the physical description of the final machine. One of the components of that file is the type and physical location, including the Physical Channel Identifier (PCHID) value assigned to that location, of all the I/O features in the final machine. This file is called a CFReport.

lack at least one PCHID that you need to insert or may contain obsolete PCHIDs that you want to update. With HCM, you can retrieve the type of an IODF using *File ---> IODF Details*.

2. Use the REXX utility **CBDSIOCP** to export the I/O configuration from the validated work IODF to a valid IOCP (with PCHIDs still missing or obsolete). The I/O configuration token is passed with the IOCP statements (TOK keyword). This token is used to assure that during the process of assigning PCHID values the contents of the IODF is not changed.

Download this IOCP data set to the workstation where the CMT is running.

3. The output of a successful CMT run is again an IOCP data set which contains the original I/O definitions together with inserted and/or updated PCHID values assigned to all CHPIDs. The original I/O configuration token is still contained in the generated statements.
4. Upload the new IOCP data set to the host and use the REXX utility **CBDSMIGR** with option **C** (physical channel ID (PCHID) migration) to import the PCHIDs from the updated IOCP data set into the validated work IODF.

When importing these statements into the validated work IODF via the migration process for PCHID migration, HCD verifies that the token passed with the IOCP statements matches the token stored in the IODF. If this is the case, and the logical I/O definition described by the imported IOCP statements does not differ from the IODF data, HCD writes the PCHID values into the IODF. If the token does not match (for example, because the IODF has been updated in the meantime), a PCHID migration will not be performed. In this case, you must start the process from the beginning.

5. If a PCHID migration has been done successfully, start the task to build a production IODF again using HCM or the REXX utility **CBDSPROD**. HCD now builds a production IODF containing all the data that is required to write the I/O configuration data set (IOCDS) via the IOCP program to the Support Element (SE) of the machine, ready to be used for the next IML.

To support the algorithm of mapping the logical CHPID definitions to physical channels, a CMT user can specify priorities to the control units (CU priorities). It is possible to preserve these values across different invocations of the CMT. For this purpose, the CMT passes the CU priorities as special comments to HCD. HCD takes these comment lines and stores them in the IODF attached to the corresponding processor. When generating an IOCP input file for the CMT, HCD includes these comments into the generated statements. HCD does not make these comments visible in the HCD dialog or in the reports.

---

## Specify a Production IODF for IPL

You need to specify your configuration definition at IPL during initial install, upgrade, and recovery. Any other time that you need to make a configuration change, you can make the change dynamically without an IPL or POR if you are using the dynamic capability of HCD.

VM offers the following options to define I/O to CP:

1. Using **HCPRIO ASSEMBLE** in the CP nucleus
2. For building the software configuration, by sensing most devices and specifying the rest using the **SYSTEM CONFIG** file or **SET RDEVICE** command
3. Using the defined I/O configuration in a production IODF

The first two ways are discussed in *z/VM: CP Planning and Administration*. The third way is handled in the rest of this section.

If you want to use z/VM HCD to define or change the I/O configuration, you must put an IODF statement into the SYSTEM CONFIG file on the PARMDISK used at IPL. This statement is used to identify the production IODF at IPL. The syntax is:

```
IODF IODFnn|* [osconfig [SYSTEM_CONS]]
```

Note that either IODFnn or \* can be specified, as follows:

- IODFnn specifies the filename of the production IODF to be used. The filename must be specified in the form IODFnn, and the filetype used will be PRODIODF. This file must be located on the system parameter disk (SYSPARM) at system IPL time.
- \* specifies that the filename of the production IODF to be used is the one currently stored in the hardware configuration token in the HSA. That filename must be in the form of IODFnn and the filetype used will be PRODIODF. This file must be located on the system parameter disk (SYSPARM) at system IPL time.

See *z/VM: CP Planning and Administration* for more information on the IODF statement.

z/VM HCD looks for operator consoles in the IODF first. If none is found, then, if parameter SYSTEM\_CONS is specified, the system console is taken.

The user has the choice to build the software configuration from this production IODF. In that case, in parameter osconfig, the IODF statement must also contain the VM configuration ID of the software definitions in the IODF. Alternatively, the user can choose to initialize the devices from device sensing and RDEVICE statements without using the IODF. For that case, no VM configuration ID has to be specified with the IODF statement in the SYSTEM CONFIG file. Note that hardware changes would still be possible using HCD provided that the HSA token matches a processor token in the specified IODF.

The following describes the case when a VM configuration ID has been specified in the IODF statement. CP will build RDEV control blocks from the devices defined in the VM configuration. All other device numbers will not be accepted even if they could be sensed or have been included as RDEVICE macro statements in the HCPRIO file.

The IODF statement is optional. Once an IODF statement has been processed in the SYSTEM CONFIG file, z/VM HCD controls the hardware and/or software I/O configuration. Therefore, any SYSTEM CONFIG statements that affect the I/O configuration are ignored.

The following list shows which statements are **always** ignored when an IODF statement is specified in the system configuration file:

- Subsequent IODF statements (i.e. only the first IODF statement remains valid)
- FEATURES DISABLE/ENABLE DYNAMIC\_IO
- FEATURES DISABLE/ENABLE SET\_DYNAMIC\_IO

The following list shows which statements are only ignored when an IODF statement of the form IODF prodiodef osconfig SYSTEM\_CONS is specified:

- RDEVICE
- DEVICES ACCEPTED/NOTACCEPTED
- DEVICES DYNAMIC\_I/O/NOTDYNAMIC\_I/O
- DEVICES OFFLINE\_AT\_IPL/ONLINE\_AT\_IPL

- DEVICES SENSED/NOTSENSED
- DEVICES SHARED/NOTSHARED
- HOT\_IO\_RATE
- OPERATOR\_CONSOLES
- EMERGENCY\_MESSAGE\_CONSOLES
- FEATURES DISABLE/ENABLE SET\_DEVICES

See *z/VM: CP Planning and Administration* for more information on device initialization and the IODF system configuration file statement.

If CP encounters an error with the processing of the IODF statement, IPL enters a disabled wait state.

To modify the I/O configuration after IPL, you have two choices:

- If the I/O configuration has been defined and initialized via HCD, HCD supports a dynamic software and hardware changes using the **CBDSACT** utility. (See “Utility CBDSACT” on page 166.)
- You can disable HCD using the **DISABLE HCD** command to disable the dynamic I/O capabilities of z/VM HCD for the rest of the current IPL and to give CP the ability to dynamically control the I/O configuration using the **SET DYNAMIC\_IO** command. For a description of this command refer to the *z/VM: CP Commands and Utilities Reference*.

Hardware changes using HCD are possible as long as the current IODF stays in sync with the Channel Subsystem configuration in the HSA. If HCD is disabled and CP commands are used directly for hardware changes, the HSA token is invalidated for HCD, and no further hardware changes using HCD are possible. To regain the capability to use HCD for hardware changes, a POR is required with an IOCDs written by HCD.

---

## Activate a Configuration Dynamically

The system programmer can dynamically make changes to a running configuration. That is, the possibility is offered to change from a currently active configuration to some other configuration that is to be made active without the need to POR or IPL the system again.

When activating a software and/or hardware configuration dynamically, HCD compares the currently active IODF with the IODF that is to be activated and then processes the difference.

This section handles the following topics:

- “Actions to Change Your Configuration Dynamically”
- “Dynamically Changing an I/O Configuration” on page 55
- “Dynamically Changing Components in an I/O Configuration” on page 55
- “Testing Dynamic Activation” on page 64
- “Recovery during Dynamic Configuration” on page 64
- “If Dynamic Activation Fails” on page 64

### Actions to Change Your Configuration Dynamically

Changes to an I/O configuration include adding, deleting, and modifying the definitions of I/O components:

- You add an I/O component to the configuration definition by including the component's description in an IODF. You use HCM to add the component to a work IODF and create a production IODF from the work IODF.
- You delete an I/O component from the configuration definition by removing the component's description from an IODF. You use HCM to delete the component from a work IODF and create a production IODF from the work IODF.
- You change an I/O component in the configuration by changing the value of a characteristic in the component description in the IODF. You use HCM to change component characteristics in a work IODF and create a production IODF from the work IODF.

In most cases, you will make simultaneous dynamic configuration changes to both hardware and software configuration definitions. However, in some cases making a change to only the software definition is useful. See “Making Both Hardware and Software Dynamic Changes” on page 54 and “Making Software-Only Dynamic Changes” on page 54.

**Note:** For an LPAR processor, first perform software only changes for the first  $n-1$  partitions and then a hardware and software change to the  $n$ th partition.

The following general actions are performed to define a configuration dynamically:

1. Verify that each I/O device that you plan to delete is not needed by any application or logical partition by varying the I/O device and its associated subchannel offline.
2. Check that the current software I/O configuration definition matches the hardware I/O configuration.

Use the following commands to find out whether HCD is in control of the hardware and/or software I/O configuration and to find out information about the current token.

- QUERY HCD
- QUERY TOKEN [CURRENT]

For a description of these commands refer to the *z/VM: CP Commands and Utilities Reference*.

3. Create a new work IODF from the production IODF.
4. Change the work IODF to define the new I/O configuration.
5. Create a production IODF from the work IODF.
6. If desired, physically remove the devices that you are deleting.
7. Optionally, test the configuration before you actually activate it. See “Testing Dynamic Activation” on page 64 for more information about testing an activation. Testing the configuration before activating it is strongly recommended.
8. Use the **CBDSACT** REXX utility to activate the new IODF and to write and switch to the new IOCDS for the new default IOCDS at the next POR.  
See “Dynamically Changing an I/O Configuration” on page 55 for a description of activating changes in logical partitions. For a software and hardware dynamic activation, the software and hardware configurations must match. When they match, activation occurs. When they do not match, activation does not occur.
9. If desired, install the new I/O components.
10. Optionally, create a backup copy of the new production IODF in case you lose your DASD.

11. Update or create the IODF statement in the SYSTEM CONFIG file so that the new production IODF will be selected at IPL.

See “Dynamically Changing Components in an I/O Configuration” on page 55 for more specific information for the type of I/O component you are defining. See “Recovery during Dynamic Configuration” on page 64 for a description of the steps to take to recover if your system fails while making a dynamic configuration change.

## Making Both Hardware and Software Dynamic Changes

To make hardware and software changes, follow these steps:

1. Plan for changing the device configuration. For deleting devices, verify that the device is not needed by any application running in the processor and that the device and its associated subchannel are offline. See “Making Dynamic Changes to I/O Devices” on page 56 for more information.
2. Describe the new I/O configuration definition in an I/O definition file (IODF) based on the currently active IODF. You can create a new work IODF with the **CBDSWORK** utility from the current production IODF.
3. Activate the new IODF using the **CBDSACT** REXX utility. Before activating the new IODF, use **CBDSACT** with the **TEST** option.

Do **not** specify the **SOFT** keyword for hardware and software changes.

Use the **ACTIOCDS=yy** keyword of this utility to write a new I/O configuration data set (IOCDS), if one does not already exist. Thus you make the new IOCDS the default for the next POR. If necessary update the IODF statement in the SYSTEM CONFIG file to point to the new IODF.

4. Install the new I/O components that you have dynamically added through the new IODF. As required, perform the following tasks:

- Configure the channel paths.
- Initialize devices, for example, format DASD with the volume serial.
- Issue the **VARY ONLINE** command to make the device available to the system, for example:

```
VARY ONLINE SUB dddd  
VARY ONLINE dddd
```

## Making Software-Only Dynamic Changes

Although, you will usually make hardware and software dynamic changes, there are times when a software-only change is useful:

- When the software I/O configuration does not match the hardware I/O configuration. For example, when the IODF that you used for IPL does not contain the hardware I/O configuration used to create the IOCDS.

You can use the software-only change to synchronize the software definition to the hardware definition so that a subsequent hardware and software change can be activated. When a software-only change switches the IODF, the new IODF can contain a processor configuration token that matches the current processor configuration token in HSA.

- When multiple logical partitions are running. You make software-only changes in all partitions except one; in the remaining partition, you make a software and hardware change. (See “Dynamically Changing an I/O Configuration” on page 55).

- When z/VM is running on a processor that does not support dynamic configuration changes to hardware I/O configuration definitions. You can still make a software-only change, for example, to change the definition of a device from not shared to shared.

To make software-only changes, follow these steps:

1. Plan for your changes to the device definitions in the configuration. For deleting devices, verify that the device is not needed by any application running in the processor. See “Making Dynamic Changes to I/O Devices” on page 56 for more information.
2. Describe the new I/O configuration definition in an I/O definition file (IODF) that you create through HCD.
3. Activate the new IODF using the **CBDSACT** REXX utility. Choose either of the following options:
  - Activate software configuration only and validate hardware changes (keyword **SOFTVAL**). This option is only valid if the SW configuration matches the HW I/O configuration.
  - Activate software configuration only (keyword **SOFTNOVAL**).

## Dynamically Changing an I/O Configuration

Any single logical partition can make dynamic configuration changes that affect the hardware configuration for all the other logical partitions. To eliminate unwanted disruption across logical partitions (to not delete hardware I/O components that are in use by another logical partition), you must follow these steps:

1. In all logical partitions *except one*, use HCD to make software-only changes. (See “Making Software-Only Dynamic Changes” on page 54). Think of the software only changes in these partitions as step 1. Use the **CBDSACT** REXX utility with the **SOFTVAL** option. As you make the software-only changes to each logical partition, the system validates that the I/O components being deleted are not in use.
2. In the *remaining* one logical partition, use HCD to make both hardware and software changes. (See “Making Both Hardware and Software Dynamic Changes” on page 54). Think of the hardware and software change in this remaining partition as step 2. Use the **CBDSACT** REXX utility and omit the **SOFTVAL** option.

## Dynamically Changing Components in an I/O Configuration

You can dynamically add, modify, or delete components in the configuration. You can make software and hardware changes or software-only changes. In most cases, you will make simultaneous dynamic configuration changes to both hardware and software configuration definitions. The following sections describe how to dynamically change component definitions. For software-only changes, you do not have to perform all the steps. It is noted when the step is not required for a software-only change.

Any dynamic configuration addition, modification, or deletion requires the following two general steps:

- Describe the new I/O configuration definition in an I/O definition file (IODF).
- Activate the new IODF.

Use the **CBDSACT** REXX utility to dynamically test and activate a new I/O configuration definition.

Additional steps related to specific I/O components are described in

- “Making Dynamic Changes to I/O Devices”
- “Making Dynamic Changes to Channel Paths (CHPIDs)” on page 58
- “Making Dynamic Changes to I/O Control Units” on page 59
- “Making Dynamic Changes to Logical Partitions” on page 61

Coupling facility device and control unit definitions in the IODF are created or deleted automatically when coupling facility channel paths are connected or disconnected. See “Making Changes to Coupling Facility Devices and Control Units” on page 62.

## **Making Dynamic Changes to I/O Devices**

You can dynamically add, modify, or delete device definitions.

**Dynamically Adding I/O Devices:** To dynamically add an I/O device, use the following general steps:

1. Describe the new I/O configuration definition in an I/O definition file (IODF).
2. Activate the new IODF.
3. Install the new I/O devices that you have dynamically added through the new IODF. As required, format the I/O devices.

Besides these general actions to add a device, other actions might be required to make certain devices usable. For example, adding a direct access storage device (DASD) to support a page data set requires the following additional actions:

1. Install the DASD.
2. Run the ICKDSF program to format a volume on the DASD.
3. Vary the DASD online to CP.

This procedure adds the device definition to CP and HSA.

### **Note:**

1. You can add a new bank of DASD using the same procedure, but perform the steps for all the DASDs in the bank.
2. Dynamically deleting parallel access volumes (PAV) devices in z/VM may be a two-step process:
  - a. In a first activation, the PAV-alias devices have to be deleted.
  - b. In a second activation, the PAV-base devices can be deleted.

To determine if two steps are necessary, you can use the QUERY PAV command to find out whether alias devices are allocated to a base device.

**Dynamically Deleting I/O Devices:** To dynamically delete an I/O device, use the following general steps:

1. For each device that you plan to delete, make sure that it is not needed by any application running in the processor. In a Processor Resource / System Management (PR/SM) environment, this includes applications running in any logical partition in your processor. See “Dynamically Changing an I/O Configuration” on page 55.
2. For each device that you plan to delete, make sure that the device and its associated subchannel are offline and not in use. CTC and TP devices must also not be allocated.
3. Describe the new I/O configuration definition in an I/O definition file (IODF).

4. Vary the devices and subchannels offline. If desired, physically remove the I/O devices that you have dynamically deleted through the new IODF.
5. Activate the new IODF.

This procedure deletes the device definition from CP and HSA.

**Dynamically Changing I/O Devices:** To dynamically change a device, use the following general steps:

1. For devices that you plan to modify, if you are changing certain fields in the IODF, you must vary devices offline.

To guard against losing I/O access unexpectedly, you must vary offline I/O devices before you activate an IODF that changes the characteristic fields described in Table 3. You might need to cancel applications that have a device allocated to get the device offline and TP and CTC devices must also be unallocated.

*Table 3. Dynamic I/O Offline Requirements for Device Characteristic Fields*

Vary the affected I/O components offline before activating a new IODF that changes these device characteristics:	Before activating the new IODF, take the following actions:
<ul style="list-style-type: none"> <li>• Unit Address</li> <li>• Device Type</li> </ul>	In each logical partition that can access the I/O device, vary the I/O device offline.
<ul style="list-style-type: none"> <li>• Connected to CUs</li> </ul>	<p>In each logical partition that will lose access to this I/O device, vary the I/O device offline.</p> <p>In each logical partition that will be able to access the I/O device through other control units, vary offline only the logical paths associated with the control unit.</p>
<ul style="list-style-type: none"> <li>• Device Candidate List</li> </ul>	In each logical partition that will lose access to this I/O device, vary the I/O device offline.
<ul style="list-style-type: none"> <li>• OS parameters and features</li> </ul>	Only in the logical partition where the activation is performed.

You do **not**, however, have to vary an I/O device offline before activating an IODF when you change any of the following I/O device characteristics:

- Serial Number
  - Description
  - TIMEOUT
  - STADET (Status Detection)
  - Preferred CHPID
2. Describe the new I/O configuration definition in an I/O definition file (IODF).
  3. Activate the new IODF.

**Limitations On Dynamic Changes To I/O Devices:** Even though a device supports dynamic configuration, the system environment might not allow dynamic changes that would add, modify, or delete the device definition.

- You cannot dynamically add certain devices. These include devices for which device support code was not loaded at IPL.

- You cannot dynamically modify or delete certain devices. These include devices containing files that you must never unallocate, such as the device containing the system residence volume, directory, paging, and spooling.

## **Making Dynamic Changes to Channel Paths (CHPIDs)**

You can add, modify, and delete channel path definitions.

**Dynamically Adding Channel Paths (CHPIDs):** To dynamically add a channel path, use the following general steps:

1. Describe the new I/O configuration definition in an I/O definition file (IODF).
2. Activate the new IODF.
3. Install the new I/O components that you have dynamically added through the new IODF. Vary the channel paths online to CP.

**Dynamically Deleting Channel Paths (CHPIDs):** How you dynamically delete a channel path depends on whether or not that channel path shares any control units and devices with one or more other channel paths.

To delete a channel path that *is* the only channel path attached to *all* its devices and control units, use the following general steps:

1. Describe the new I/O configuration definition in an I/O definition file (IODF). Create an IODF that defines neither the channel path nor its devices and control units.
2. Make sure the channel path and its devices and control units are not in use by any application.
3. Vary all I/O devices on the channel path offline to CP (VARY PATH command).
4. Vary the channel path offline to CP (VARY CHPID command).
5. If desired, physically remove the channel path and all I/O devices and control units on the channel path.
6. Activate the new IODF.

To delete a channel path that is *not* the only channel path attached to its devices and control units, use the following general steps:

1. Describe the new I/O configuration definition in an I/O definition file (IODF) . Create an IODF that meets both of the following requirements:
  - The new IODF does not define the channel path or the devices and control units attached exclusively on the channel path.
  - The new IODF does define those device and control units also attached on other channel paths.
2. Make sure that no devices and control units on this channel path are in use by this channel path.
3. For all devices not exclusively on this channel path, vary offline to CP all device paths through this channel path.
4. Vary offline to CP all devices exclusively on this channel path (VARY PATH command).
5. Vary the channel path offline to CP (VARY CHPID command).
6. If desired, physically remove the channel path and the I/O devices and control units *exclusively* on this channel path.
7. Activate the new IODF.

**Dynamically Changing Channel Paths (CHPIDs):** To dynamically change a channel path, use the following general steps:

1. For channel paths that you plan to change, if you are changing **certain** fields in the IODF, you must vary channel paths offline.

To guard against losing I/O access unexpectedly, you must vary offline I/O devices before you activate an IODF that changes the characteristic fields described in Table 4:

Table 4. Dynamic I/O Offline Requirements for Channel Path Fields

Vary the affected components offline before activating a new IODF that changes these channel path characteristics:	Before activating the new IODF, take the following actions:
<ul style="list-style-type: none"> <li>• Channel Path Type</li> <li>• Dynamic Switch ID</li> <li>• Operation Mode (REC/DED/SHR)</li> </ul>	<p>In all logical partitions in your processor complex, configure the channel path offline. If the channel path is the last path to an I/O device, you must vary the device offline before you can configure the channel path offline.</p>
<ul style="list-style-type: none"> <li>• Channel Path Access List</li> <li>• Channel Path Candidate List</li> </ul>	<p>In each logical partition that will lose access to I/O devices on this channel path, do the following:</p> <ol style="list-style-type: none"> <li>1. For I/O devices that will become inaccessible to the logical partition, vary those I/O devices offline.</li> <li>2. For I/O devices that will remain accessible by the logical partition through other channel paths, vary offline only the logical paths associated with this channel path.</li> <li>3. Configure the channel path offline.</li> </ol> <p><b>Note:</b> For coupling facility sender channel paths, you must first vary the CF sender channel path offline to the coupling facility.</p> <p>In all logical partitions that will gain access or continue accessing this channel path, you need not configure or vary anything offline.</p>

You do **not**, however, have to vary an I/O device offline before activating an IODF when you change any of the following I/O device characteristics:

- Entry Switch Number
  - Entry Port
  - Description
2. Describe the new I/O configuration definition in an I/O definition file (IODF).
  3. Activate the new IODF. With the **CBDSACT** REXX utility, specify the **FORCECAN** option.

**Note:** You usually cannot remove a logical partition from a channel path candidate list unless the channel path is offline. You can, however, remove a logical partition, other than your own, from the channel path candidate list for a reconfigurable or shared ESCON or FICON connection or coupling facility sender channel path while the channel path is online to the other logical partition if you perform one of the following actions:

## Making Dynamic Changes to I/O Control Units

You can add, modify, and delete I/O control unit definitions.

**Dynamically Adding I/O Control Units:** To dynamically add an I/O control unit, use the following general steps:

1. Describe the new I/O configuration definition in an I/O definition file (IODF).
2. Activate the new IODF.

**Dynamically Deleting I/O Control Units:** CP verifies that the I/O control units are not in use (that the set of all device paths are offline) before deleting the control unit.

How you dynamically delete a control unit depends on whether or not that control unit shares any devices with one or more other control units.

To delete a control unit that is the only control unit attached to *all* its devices, use the following general steps:

1. Describe the new I/O configuration definition in an I/O definition file (IODF). Create an IODF that defines neither the control unit nor its attached devices.
2. Make sure that none of the devices on the control unit are in use by any application.
3. Vary all subchannels and devices on the control unit offline to CP.
4. If desired, physically remove the control unit and all its attached devices.
5. Activate the new IODF.

To delete a control unit attached to any devices that are *also* attached to one or more other control units, use the following general steps:

1. Describe the new I/O configuration definition in an I/O definition file (IODF). Create an IODF that meets both of the following requirements:
  - The new IODF does not define the control unit or its exclusively attached devices.
  - The new IODF does define those devices also attached to other control units.
2. Make sure that none of the devices exclusively on this control unit are in use by any application.
3. Vary offline to CP all subchannels and devices exclusively on the control unit. For all devices also attached to other control units, vary offline to CP all device paths through this control unit.
4. If desired, physically remove the control unit and all its exclusively attached devices.
5. Activate the new IODF.

**Dynamically Changing I/O Control Units:** To dynamically change an I/O control unit, use the following general steps:

1. For control units that you plan to change, if you are changing **certain** fields in the IODF, you must vary attached devices offline.

To guard against losing I/O access unexpectedly, you must vary offline I/O devices before you activate an IODF that changes the characteristic fields described in Table 5 on page 61:

Table 5. Dynamic I/O Offline Requirements for Control Unit Fields

<p><b>Vary the affected I/O components offline before activating a new IODF that changes these control unit characteristics:</b></p>	<p><b>Before activating the new IODF, take the following actions:</b></p>
<ul style="list-style-type: none"> <li>• Control Unit Type</li> <li>• Link Address</li> <li>• Logical Address</li> <li>• Protocol</li> <li>• I/O Concurrency Level</li> </ul>	<ul style="list-style-type: none"> <li>• Vary offline all I/O devices and subchannels connected to the control unit.</li> </ul>
<ul style="list-style-type: none"> <li>• Channel Path IDs</li> </ul>	<p>In each logical partition that will lose access to I/O devices on this control unit, do the following:</p> <ol style="list-style-type: none"> <li>1. For I/O devices that will become inaccessible to the logical partition, vary those I/O devices and subchannels offline.</li> <li>2. For I/O devices that will remain accessible by the logical partition through other channel paths, vary offline only the logical paths that you are removing from this control unit.</li> </ol>
<ul style="list-style-type: none"> <li>• Unit Addresses (with Ranges and Numbers of Units)</li> </ul>	<p>Before deleting a unit address, vary its associated I/O device and subchannel offline.</p>

You do **not**, however, have to vary an I/O device offline before activating an IODF when you change any of the following control unit characteristics:

- Serial Number
  - Description
2. Describe the new I/O configuration definition in an I/O definition file (IODF).
  3. Activate the new IODF.

## Making Dynamic Changes to Logical Partitions

You can dynamically add or delete LPAR definitions, as described below.

**Dynamically Adding New Logical Partitions (LPARs):** To dynamically add a logical partition, use the following general steps:

1. Make sure an LPAR is '\*' reserved in the IODF file used in the IML of the processor. This can also be done using the RESOURCE statement in an IOCP during execution of the CBDSMIGR function, by specifying an '\*' for the partition name.
2. Change the '\*' reserved LPAR to an LPAR name in the new IODF file and assign resources to it.
3. Activate the new IODF. The LPAR should now be added. Issue QUERY LPARS. (See *z/VM: CP Commands and Utilities Reference* for more information.)
4. Go to the HMC and define an LP activation profile. (Note that activating the new LP should automatically bring online all of the CHPIDs defined in the initial access list.)
5. IPL your new LPAR.

**Dynamically Deleting Logical Partitions (LPARs):** To dynamically delete a logical partition, use the following general steps:

1. In order to delete a logical partition, you must first disconnect it from the rest of the I/O configuration so that it is no longer an active partition.
2. Change the LPAR name to a reserved '\*' name in the new IODF file.
3. Activate the new IODF. The LPAR should now be a reserved '\*' partition. Issue QUERY LPARS. (See *z/VM: CP Commands and Utilities Reference* for more information.)

**Notes on Dynamically Adding or Deleting Logical Partitions (LPARs):** Keep in mind the following considerations when dynamically adding or deleting logical partitions:

- You cannot dynamically delete an active logical partition from the I/O configuration.
- After you assign a name to a partition, you can assign dedicated CHPIDs for that partition and add the partition to the candidate lists of any reconfigurable, shared, or spanned CHPIDs.
- Before deleting a logical partition from the I/O configuration by unassigning the partition name, you must unassign any dedicated CHPIDs defined for the partition. If there are any reconfigurable, shared, or spanned CHPIDs defined for the partition, you must remove the partition name from the candidate list for those CHPIDs.
- When you delete a logical partition from the I/O configuration dynamically, you do not have to delete the partition from each device's candidate list, unless you used an explicit candidate list when you defined the device.
- When deleting a logical partition, make sure that no CRYPTO card is assigned to this LPAR (not visible for HCD).

## **Making Changes to Coupling Facility Devices and Control Units**

Coupling facility devices and control units are defined to represent the connections in the channel subsystem connection to a coupling facility. The coupling facility control unit and device definitions are created in an IODF when you connect CF sender and CF receiver channel paths or two CF peer channel paths using HCD. One coupling facility control unit and two coupling facility devices are defined when you first connect a CF sender channel path to a CF receiver channel path for a coupling facility. Each subsequent channel connection adds two more coupling facility device definitions. For a CF peer channel connection, one control unit and seven CF device definitions are generated on one or on both sides of the connection depending on whether the sending function is used on only one or on both sides of the connection. You do not explicitly add or delete coupling facility devices and control units in the IODF; they are added and deleted based on the CF sender-to-receiver or peer-to-peer channel connections that you make.

A CF sender-to-CF receiver or peer-to-peer connection can cause changes to a coupling facility control unit definition. The first path you connect adds the coupling facility control unit and the last path you disconnect deletes the coupling facility control unit, but all other connections and disconnections of channel paths change the control unit definition.

The following sections describe how dynamic changes are made to coupling facility devices and control units when you connect and disconnect channel paths for a processor.

**Making the First Channel Path Connection for a Coupling Facility:** When you connect the first CF sender channel path to a CF receiver channel path for a coupling facility, HCD creates a coupling facility control unit and two coupling

facility device definitions in an IODF. When you connect the first two CF peer channel paths for a coupling facility, HCD creates a coupling facility control unit and seven coupling facility device definitions in an IODF.

Perform the following steps when you connect the first CF sender channel path or CF peer channel path:

1. Connect a CF sender channel path to a CF receiver channel path, or connect two CF peer channel paths.
2. Accept or change the control unit and device numbers HCD proposes.
3. Activate the new IODF.
4. Install the channel path.
5. Vary the channel path online.

**Making Subsequent Channel Path Connections for a Coupling Facility:** When you make subsequent CF sender-to-CF receiver channel path connections for a coupling facility, HCD creates two coupling facility device definitions in the IODF. When you make subsequent CF peer-to-peer channel path connections for a coupling facility, HCD creates seven coupling facility device definitions in the IODF. For both the CF sender channel path connection and the CF peer channel path connection, HCD also changes the existing coupling facility control unit definition to reflect the new channel path connection in the IODF.

Perform the following steps when you connect subsequent CF sender or CF peer channel paths:

1. Connect a CF sender channel path to a CF receiver channel path, or connect two CF peer channel paths.
2. Accept or change the device numbers proposed by HCD.
3. Activate the new IODF.
4. Install the channel path.
5. Vary the channel path online.

**Breaking a Channel Path Connection that Is Not the Last Connection to a Coupling Facility:** When you disconnect a CF sender channel path connection that is not the last connection for a coupling facility, HCD deletes two coupling facility device definitions in the IODF. When you disconnect a CF peer channel path connection that is not the last connection for a coupling facility, HCD deletes seven coupling facility device definitions in the IODF. For both the CF sender channel path disconnection and the CF peer channel path disconnection, HCD also changes the existing coupling facility control unit definition to reflect the channel path disconnection in the IODF.

Perform the following steps when you disconnect a CF sender or a CF peer channel path that is not the last channel path connection to the coupling facility:

1. Disconnect a CF channel path from the CF receiver channel path, or disconnect the two CF peer channel paths.
2. Vary the disconnected channel path offline.
3. Activate the new IODF.

**Breaking the Last Channel Path Connection to a Coupling Facility:** When you disconnect the last CF sender channel path connection for a coupling facility, HCD deletes a coupling facility control unit and two coupling facility device definitions

in the IODF. When you disconnect the last CF peer channel path connection for a coupling facility, HCD deletes a coupling facility control unit and seven coupling facility device definitions in the IODF.

Perform the following steps when you disconnect the last CF sender channel path or the last CF peer channel path from a coupling facility:

1. Quiesce activity to the coupling facility.
2. Disconnect the last CF sender or CF peer channel path from a processor to a coupling facility in the IODF definition.
3. Activate the new IODF.

## Testing Dynamic Activation

When you dynamically activate a new I/O configuration, you can choose to first run in test mode, to see if the activation will run. This is strongly recommended. If the test indicates a problem, HCD displays error messages in the message log (CBDSACT MSGLOG). The test function includes the following checks:

- The IODF specified for activation exists and is a production IODF.
- The new configuration information will fit into the current HSA.
- I/O devices that you are deleting are offline.
- Paths that you are deleting are offline.
- The activation specifies an IODF that matches the configuration definition in HSA.
- The specified IOCDS is a valid data set.
- The activation is not changing partition names or the number of partitions.
- Any new processor has at least one CHPID identified for it.
- The activation does not change a processor type or configuration mode.
- The activation does not cause a physical control unit to be added to a logical control unit if the addition causes two logical control units (with devices attached) to merge into one logical control unit.
- The activation does not cause a physical control unit to be removed from a logical control unit if the deletion causes a split of one logical control unit (with devices attached) into two logical control units.

Using the **CBDSACT** REXX utility with the **TEST** option, you can perform the above test functions before you really activate the configuration.

If you activate hardware and software in test mode, HCD provides information about channel paths, control units, and devices that are deleted, modified, or added.

## Recovery during Dynamic Configuration

If your system fails while making dynamic configuration changes to the hardware definition, you can recover the I/O configuration even if the system failure required a re-IPL, because the current status of the activation process is stored in the HSA. You can issue the **QUERY HCD** command (see the *z/VM: CP Commands and Utilities Reference*) to determine if HCD is in a state that requires recovery.

### If Dynamic Activation Fails

If the activation is rejected, HCD provides a message log file (CBDSACT MSGLOG) that lists the messages and reasons for a failure.

In some cases a dynamic activation may fail and HCD recommends recovery.

- If you invoke **CBDSACT** with the RECOVER option, HCD performs *hardware and software changes*.  
You can specify to recover in two ways:
  - To resume activation of the target IODF. That is, HCD tries to continue with the activation. This is the default.
  - To reset the configuration to the source IODF. That is, HCD activates the configuration that existed before the failure occurred.
- If you do not perform recovery, HCD allows you to continue with *software-only changes*. Hardware changes are activated up to the point where the failure occurred.

### Recovering Dynamic Configuration Changes

After a failure during a dynamic configuration change, you can either recover the configuration that was active before the failure or continue making changes from the point of failure and complete the configuration change. In the latter case, HCD must have access to both the source IODF, which defines the original I/O hardware configuration, and the target IODF, which defines the new I/O hardware configuration.

**Recovering Original I/O Configuration without Re-IPL:** If the system failure does not require a re-IPL, and you want to recover the I/O configuration that was active before the failure, do the following:

- Invoke the **CBDSACT** utility with the RECSRCE option. CP backs out all dynamic I/O hardware changes made prior to the failure, returning the system to its original (source) I/O hardware configuration.

**Continuing I/O Configuration Changes without Re-IPL:** If the failure does not require a re-IPL, and you want to continue making dynamic configuration changes from the point of failure, do the following:

- Invoke the **CBDSACT** utility with the RECTARG option. CP continues making the remaining dynamic configuration changes, finishing building the new (target) I/O hardware configuration. If you do not specify TARGET or SOURCE option, CP continues in the same direction as when failure occurred.

**Recovering Original I/O Configuration with Re-IPL:** If the system failure requires a re-IPL, and you want to recover the I/O configuration that was active before the failure, follow these steps:

1. Specify the source IODF in the IODF statement of the SYSTEM CONFIG file.
2. Re-IPL the system.
3. Invoke the **CBDSACT** utility with the RECSRCE option. CP backs out all dynamic hardware changes made prior to the failure, returning the system to its original (source) I/O hardware configuration.

**Continuing I/O Configuration Changes with Re-IPL:** If the failure requires a re-IPL, and you want to continue making dynamic configuration changes from the point of failure, follow these steps:

1. Specify the target IODF in the IODF statement of the SYSTEM CONFIG file.
2. Re-IPL the system.
3. Invoke the **CBDSACT** utility with the RECTARG option. CP continues making the remaining dynamic changes, finishing building the new (target) I/O hardware configuration.

## Recovering Dynamic Configuration Changes

After a failure during a dynamic configuration change, you can recover the system to its original I/O configuration or continue making dynamic configuration changes from either the logical partition that had failed or from any other logical partition.

**Recovering Original I/O Configuration without System Reset:** If the failure does not require a system reset and you want to recover the I/O configuration that was active before the failure occurred, follow these steps:

1. In all logical partitions, to make software-only changes, activate the source IODF.
2. In any logical partition, invoke the **CBDSACT** utility with the RECSRCE option. CP backs out all dynamic configuration changes made prior to the failure, returning the system to its original (source) I/O hardware configuration, which is shared by all logical partitions.

**Continuing I/O Configuration Changes without System Reset:** If the failure does not require a system reset and you want to continue making dynamic configuration changes from the point of failure, do the following:

- In any logical partition, invoke the **CBDSACT** utility with the RECTARG option. CP continues making the remaining dynamic configuration changes, finishing building the new (target) I/O hardware configuration, which is shared by all logical partitions.

**Recovering Original I/O Configuration with System Reset:** If the failure requires a system reset and you want to recover the I/O configuration that was active before the failure occurred, follow these steps:

1. In the logical partition that failed, specify the source IODF in the IODF statement of the SYSTEM CONFIG file.
2. Perform system reset on the logical partition that failed.
3. In all logical partitions, make software-only changes, activating the source IODF.
4. In any logical partition, invoke the **CBDSACT** utility with the RECSRCE option. CP backs out all dynamic configuration changes made prior to the failure, returning the system to its original (source) I/O hardware configuration, which is shared by all logical partitions.

**Continuing I/O Configuration Changes with System Reset:** If the failure requires a system reset and you want to continue making dynamic configuration changes from the point of failure, follow these steps:

1. In the logical partition that failed, specify the target IODF in the IODF statement of the SYSTEM CONFIG file.
2. Perform system reset on the logical partition that failed.
3. In any logical partition, invoke the **CBDSACT** utility with the RECTARG option. This continues making the remaining dynamic configuration changes, finishing building the new (target) I/O hardware configuration, which is shared by all logical partitions.

## Detection of Illegal Split/Merge of LCU

If a request for activating a new configuration causes a logical control unit (LCU) to be split or merged illegally, HCD rejects the request. HCD considers an LCU to be:

- Illegally split if a physical control unit (PCU) is removed from the LCU that has devices remaining connected to it.
- Illegally merged if a physical control unit is added to an LCU that has devices connected to it.

HCD detects every split/merge during activation and informs you by message. The message tells between which PCU and which device the split/merge occurred; it also explains how to correct the condition.



---

## Chapter 9. How to Print and Compare Configuration Data

### Overview

This chapter describes how to:

- Print configuration reports (channel subsystem, switch, OS configuration data, and CTC connections)
- Print a report of the I/O paths of the actual system compared to the defined I/O configuration
- Print a report of the supported hardware or an I/O definition reference
- Create or view a graphical report of the I/O configuration
- Compare functions (IODFs and CSS/operating system views)
- View and print the activity log

---

### Print Configuration Reports

You can use HCD to generate several types of reports about the configuration data in an IODF:

- Channel Subsystem (CSS) Report
- Channel Path Detail Report
- Control Unit Detail Report
- Device Detail Report
- Switch Report
- Operating System (OS) Device Report
- OS Console Report
- CTC Connection Report
- Supported Hardware Report
- I/O Definition Reference

The REXX utility *CBDSREP* generates a report of a work IODF. With a parameter, you specify which type of report you want. How to invoke this utility is described in “Print Configuration Reports (CBDSREP)” on page 145.

In the HCD profile definition, you have the option of printing textual reports in upper case only or defining the number of lines per page (see “Options for Text Reports” on page 27).

Examples of these reports are shown in Chapter 13, “Configuration Reports,” on page 175.

### Channel Subsystem Report

The Channel Subsystem Report contains all configuration data that is used by the channel subsystem. If the IODF contains data for more than one processor or logical partition, you can limit the report to the data for one processor or partition. If you limit the report to one partition, it will generate information only for channel paths, which have the partition in the access list. Channel paths that have that partition in a candidate list will not be taken into consideration.

You can select four types of reports:

- **CSS summary reports** include summary reports about:
  - Processors
  - Channel subsystems
  - Partitions
  - PCIe functions
  - PCHIDs
  - IOCDs
  - Channel paths
  - Control units
  - Devices

The processor and partition reports are not printed if you limit the CSS summary reports to the data for one processor or partition.

- **Channel path detail reports** include reports about:
  - Channel paths
  - CF channel path connectivity
- **Control unit detail report**
- **Device detail report**

## Switch Report

The Switch Report contains details about the switch definition, its configurations and the port definitions.

If the IODF contains data for more than one switch, you can limit the report to the data for one switch and the configurations for this switch. In this case, you do not get a switch summary report.

## Operating System Report

The Operating System Report contains the configuration data that is used by z/VM. If the IODF contains data for more than one operating system, you can limit the report to the data for one operating system. You can select three types of reports:

1. The OS device report includes reports about operating systems and OS devices.  
The operating system summary report is not printed if you limit the OS device report to the data for one operating system.
2. OS console report

## CTC Connection Report

The CTC Connection Report contains CTC connections of your configuration that are defined either through a switch or point-to-point. In case of incorrect definitions, the report also contains a list of messages with diagnostic information.

If the IODF contains more than one processor or logical partition, you can limit the report to the data for one processor or partition.

### Restrictions Applying to the CTC Connection List

- HCD can only show CTC connections if the connected processors are defined in one IODF.

- For a switched SCTC connection, the CNC/FCV and CTC channel paths must be connected to the same ESCON director. CTC connections running via chained ESCON directors cannot be determined.
- CTC connections using a stand-alone CTC adapter cannot be shown.
- Point-to-point CTC connections are only recognized if the control units associated to a specific CTC connection have the same serial number defined.

## Supported Hardware Report

The Supported Hardware Report contains information about the processors, control units, and devices supported in your installation.

This report is generated directly from the UIMs. Therefore, it reflects the latest UIM levels installed.

## I/O Definition Reference

The I/O Definition Reference contains a description of the parameters to define the device to the Channel Subsystem, and a description of the parameters and features to define the device to the operating system.

---

## Create Graphical Configuration Reports

HCD offers you the ability to print a graphical representation of the I/O configuration based on the definitions in the IODF. The reports can be stored in a file for printing on an AFP™ printer (such IBM 3820 or IBM 3800).

The graphical report function lets you print or view five types of reports:

- The **LCU report** shows all logical control units defined for one processor.
- The **CU report** takes a control unit as focal point and shows the connections to the processors and the devices of the IODF. On request, it shows the switches as well.
- The **CHPID report** shows the defined channel paths for a processor and the switches, control units, and devices attached to the CHPID.
- The **Switch report** takes a switch (ESCON or FICON) as focal point and shows the processors, connected switches, and control units with devices attached to the switch.
- The **CF connection report** takes a coupling facility as focal point and shows all connections that exist between the coupling facility and the other processors defined in the IODF.

The REXX utility *CBDSDRAW* generates a graphical configuration report. How to invoke this utility is described in “Create a Graphical Configuration Report (CBDSDRAW)” on page 148.

## Prerequisites

To process the reports for printing you need one of the following:

- BookMaster Release 3.0 or higher
- DCF/GML Release 4.0

To print the reports you need an AFP printer, such as IBM 3820 or IBM 3800.

In the HCD profile, specify whether the output of this function can be processed with BookMaster, DCF, or GML (keyword GCR\_FORMAT). BookMaster is the

default. To use DCF or GML format, specify a mono- space font using the keyword GCR\_FONT. For example, specify GCR\_FONT = X0GT20 (Gothic Text 20-pitch) for a 3820 printer. For more information about the HCD profile, refer to “Defining an HCD Profile” on page 26.

## Printing the Output

1. Process the output file using BookMaster, DCF, or GML. While processing it is recommended that you specify the following parameters:

### Indexing

To print the index you selected on the Define Report Layout panel specify INDEX for BookMaster and GML processing

### Full page

To use the full page for the report SYSVAR S is to be set to 1 for DCF processing. Note that in many installations offset is used as default.

### Rotate printout

Specify a parameter to print the report in landscape format, that means to rotate the printout by 90 degree.

2. Print the report.

HCD tries to display a report on one page. If a report is too large for one page, HCD divides the report into segments and shows each segment on an extra page. If a CU report, for example, shows more than 8 control units, HCD shows the control units of the same type in one segment on an extra page. If a segment is too large for one page, HCD continues the segment on the next page. You can specify the GCR\_COMPACT=YES keyword in the HCD profile to see more objects on one page.

For an example of a report, see “Graphical Configuration Reports” on page 222.

---

## Compare Functions

This section handles the following compare functions:

- “Compare IODFs”
- “Compare CSS / Operating System Views” on page 73

The REXX utility called *CBDSCOMP* (see “IODFs or CSS/OS Compare Reports (CBDSCOMP)” on page 151) lets you specify with the help of parameters, whether you want to have an IODF Compare Report or an CSS/OS Compare Report.

## Compare IODFs

You can use the *CBDSCOMP* utility with the *IODF Compare Report* parameter, see “IODFs or CSS/OS Compare Reports (CBDSCOMP)” on page 151, to compare two IODFs and report the differences between them. For greater clarity, you can limit the compare reports to certain perspectives of the IODF:

- The *Processor Compare Report* shows differences in the properties of channel subsystems, PCIe functions, partitions, CHPIDs, control units, and devices.
- The *Switch Compare Report* shows differences in the properties of switches and switch configurations.
- The *OS Configuration Compare Report* shows differences in device parameters, in features and consoles.

## Compare CSS / Operating System Views

You can use the *CBDSCOMP* utility with the *CSS / OS Compare Report* parameter, see “IODFs or CSS/OS Compare Reports (CBDSCOMP)” on page 151, to compare the device definitions of a selected CSS and OS configuration, showing which devices (their numbers and types) are defined to either the CSS or the OS, or both. By using this parameter, you receive a printed report so that you can find out the differences between a hardware (channel subsystem/CSS) and software (operating system/OS) definition in the currently accessed IODF.

When using the *CSS / OS Compare Report* parameter, you can specify what to print. The Print all data option prints a report of all devices either defined in the CSS or the OS.

If you limit the Compare CSS/OS Views Report for the CSS-side to one partition, it will generate information only for those devices that are attached to the channel paths, that have the limiting partition in the access or candidate list.

Devices that are excluded via an explicit device candidate list are marked with an '\*'.

---

## View the HCD Activity Log

To look at the activity logs for an IODF, use an editor or browser. See “IODF and Activity Log Naming Conventions” on page 31 for more information.

**Note:** HCD maintains an activity log only if this was requested when the IODF file was created.



---

## Chapter 10. How to Migrate your Environment to z/VM HCD

To manage the I/O configuration with HCD under z/VM, you have the following options:

- You can use the provided REXX utilities to perform z/VM HCD tasks.
- You can use HCM as a graphical user interface to z/VM HCD. Therefore, you must load the HCD IODF into an HCM configuration file. For more information, refer to the *z/OS and z/VM Hardware Configuration Manager User's Guide*.
- You can decide to manage your operating system configuration in addition to the hardware, or you can use HCD just to manage your hardware I/O configuration.

If you want to use HCD to also control the operating system I/O configuration under z/VM, you have to define an operating system of type VM in the IODF, assign the appropriate devices to the VM operating system, and define the VM consoles.

As prerequisite for managing your I/O configuration with HCD, you need an IODF belonging to z/VM HCD. This document describes the steps how to produce an IODF from an IOCP deck.

The IODF contains the logical I/O configuration definitions that are required for writing an IOCDS, for building the RDEV control blocks at IPL time, and for dynamic hardware and software changes.

An HCM configuration file is always strongly associated to a specific IODF and contains logical data from this IODF as well as additional data on physical I/O configuration aspects. Thus, it contains all data that is necessary to show an I/O configuration diagram from the physical configuration point of view.

If z/OS is used in your environment, you already have an IODF file. It is then recommended to define the I/O configuration under z/OS HCD, if you decided to manage your z/VM configuration using HCD. Thus, the hardware configuration for both the z/OS and z/VM systems can be managed from a central place.

You should read Chapter 15, "Migration Scenarios to z/VM HCD for z/VM and z/OS," on page 255 if you are interested in migrating to HCD in a z/VM environment without z/OS, or migrating to HCD in a mixed z/VM and z/OS environment (this includes information on how to exchange IODF or IOCP files between z/VM and z/OS).

On z/VM, the user ID that is used for HCD/HCM is CBDI0DSP. This user ID is the *z/VM HCD TCP/IP dispatcher*. The work and production IODF files are stored on the 191 disk. The z/VM HCD/HCM production files are on the 400 disk. These include the **CBDSxxxx** REXX utilities.

---

### Migration from an IOCP

It is recommended to save the original IOCP file before preparing it for the migration task.

Before an existing IOCP file can be migrated into an IODF, in most cases, it has to be updated for the proper control unit and device types. The IOCP program,

generally, does not validate the UNIT and MODEL keywords on the CNTLUNIT and IODEVICE control statements, whereas HCD does. Therefore, these statements must have unit and model values which pass the HCD validation function.

The **Supported Hardware Report** contains details on which control unit types and device types are supported by HCD and which device types can be connected to which control unit types. You can create a **Supported Hardware Report** using the **CBDSREP** REXX utility or you can produce this report using HCM. A sample **Supported Hardware Report** is presented in *z/VM I/O Configuration*.

For generating an HCM configuration file from the IODF, it is also recommended to prepare the IOCP file by adding physical connection data using extended migration statements into the IOCP file to be migrated. Examples on how to do this are provided in “Step 1. Prepare the IOCP deck for HCD” on page 256. The HCD migrate function will put this data into the IODF, and HCM can use that additional information to produce an appropriate physical configuration diagram.

A native z/VM IOCP deck just contains I/O configuration statements according to the IOCP syntax rules. However, besides the information allowed by the IOCP syntax, HCD introduces an extended migration to allow you to define your complete logical and physical configuration in the IOCP deck. For example, the extended migration allows you to define a switch with its ports, or to define serial numbers and descriptions for devices and control units by manually editing your IOCP input file according to the syntax rules of both the IOCP statements and the HCD extended migration statements. They help you to describe your hardware and infrastructure in your IODF and help HCM to provide a more complete configuration diagram with physical aspects.

The extended migration statements are written as comments into the IOCP, prefixed by one of two tags in column 1:

- **\*\$HCD\$** prefixes extended migration statements, for example for switches and ports.
- **\*\$HCDC\$** prefixes extended migration statement keywords, for example for serial numbers and switch port connections.

The extended migration data consists of:

#### **Partition usage types**

HCD validates a logical partition either as usage for an operating system (OS) partition, a coupling facility (CF) partition, or both (CF/OS). For this case, it is recommended to add the partition usage data as comment line following the RESOURCE statement:

#### **Example:**

The following RESOURCE statement has added an \$HCDC\$ tagged comment line that defines logical partitions LP1, LP2 and LP3 with usage type OS and logical partition CF1 with usage type CF.

```
RESOURCE PART=((LP1,1),(LP2,2),(LP3,3),(CF1,4))
*$HCDC$      USAGE=(OS,OS,OS,CF)
```

#### **PCIe function type**

Specify the TYPE (alternatively UNIT for backlevel compatibility) keyword (for zEC12 and zBC12 processor PCIe functions) otherwise a problem may occur when re-migrating the IOCP data set because the PCIe Unit parameter is unknown and defaulted to 'ROCE'.

```

FUNCTION FID=051,PART=((LP01),(LP03,LP05,LP07)),
      PNETID=(PNET01,,PNET03,),PCHID=53A
*$HCDC$      TYPE=ROCE
FUNCTION FID=005,VF=1,PART=((LP14),(LP01)),PCHID=105
*$HCDC$      TYPE=ZEDC-EXPRESS

```

### Coupling facility connection information

HCD keeps connection information for the coupling facility in the IODF. This information cannot be determined from the pure IOCP statements. To put that data into the IODF, add the TPATH keyword as an \$HCDC\$ tagged comment line following a CHPID statement for a coupling facility channel path.

#### Example:

The following CHPID statement defines coupling facility peer channel path 10. It has added as comment the target and source connection information. The target is CF receiver channel 11 of processor configuration PROC1 using control unit FFFD and devices starting with FFF2 up to FFF8. The source is channel path 10 of processor PROC2 using control unit FFFE and devices starting with FFF9 up to FFFF.

```

*$HCDC$      CHPID PATH=(CSS(0,1),10),SHARED,PCHID=100,TYPE=CFP
              TPATH=((CSS(0),PROC1,11,FFFD,FFF2),
                    (CSS(0),PROC2,10,FFFE,FFF9))
              CNTLUNIT CUNUMBR=FFFE,PATH=((CSS(0),10),(CSS(1),10)),
              UNIT=CFP
              IODEVICE ADDRESS=(FFF9,007),CUNUMBR=(FFFE),UNIT=CFP

```

### Switch data

For each ESCON or FICON directors used in your configuration, pass a SWITCH comment statement.

#### Example:

The following \$HCDC\$ tagged comment line defines a FICON director 2032 with ID 10 and installed ports 04 to 43. If you have director-to-director (switch-to-switch) connections, then this information needs to be provided as well via the SWPORT comment statement, as shown in the example, where switch 10 has connections from port 06 to switch 11/port 05, from port 07 to switch 11/port 04 and from port 08 to switch 13/port 0A.

```

*$HCDC$      SWITCH SWID=10,ADDRESS=61,DESC='McData ED-6064 z/OS',
              PORT=((04,43),(FE,FE)),UNIT=2032,
              SWPORT=((06,11,05),(07,11,04),(08,13,0A))

```

### Connection information for ESCON and FICON directors (switch and port data) on CHPID and CNTLUNIT statements

For each channel path connecting to a dynamic switch (CHPID statement with SWITCH keyword) and each control unit that has link addresses defined (CNTLUNIT statement with LINK keyword), add the switch connection data as \$HCDC\$ tagged comment lines after the CHPID and CNTLUNIT statements.

#### Example:

CNC channel path 11 is connected to switch 20 port A1, control unit 0400 is connected to switch 20, ports 8B and B7, and to switch 21, ports 9A and BC.

```

*$HCDC$      CHPID PATH=(11),TYPE=CNC,SHARED,SWITCH=20
              SWPORT=((20,A1))
              CNTLUNIT CUNUMBR=0400,UNIT=3990,PATH=(20,30,40,50),
              LINK=(8B,B7,9A,BC),UNITADD=((00,256))
*$HCDC$      SWPORT=((20,8B),(20,B7),(21,9A),(21,BC))

```

### Control unit serial numbers

Specify the same serial number for all control units that belong to the same physical controller. Thus, HCM will arrange these control units into the same physical controller instance.

#### Example:

The following control units 9000 to 9300 belong to the same physical controller. HCM will put them into the same physical box if they have the same serial number defined.

```
CNTLUNIT CUNUMBR=9000,PATH=(14,16,19,1B),LINK=(E0,E4,E8,EC), *
CUADD=0,UNITADD=((00,64)),UNIT=2107
*$HCDC$ SERIAL='23425'
CNTLUNIT CUNUMBR=9100,PATH=(18,15,1A,17),LINK=(E0,E8,E4,EC), *
CUADD=1,UNITADD=((00,64)),UNIT=2107
*$HCDC$ SERIAL='23425'
CNTLUNIT CUNUMBR=9200,PATH=(14,16,19,1B),LINK=(E0,E4,E8,EC), *
CUADD=2,UNITADD=((00,64)),UNIT=2107
*$HCDC$ SERIAL='23425'
CNTLUNIT CUNUMBR=9300,PATH=(18,15,1A,17),LINK=(E0,E8,E4,EC), *
CUADD=3,UNITADD=((00,64)),UNIT=2107
*$HCDC$ SERIAL='23425'
```

HCD can recognize point-to-point CTC connections if the involved control units of a CTC connection have the same serial numbers. For more information, refer to the *z/OS and z/VM: Hardware Configuration Manager User's Guide* in the topic *Building Your Configuration*.

---

## Migrating the OS Configuration

To define the I/O configuration to the software, you can either postpone that step until you have generated the HCM configuration file from the IODF. Then, use HCM to define the VM operating system and assign the devices to this operating system. Or, you can migrate the actual operating system I/O configuration settings in terms of the RDEV control blocks into the IODF.

Migration of the RDEV control blocks can be done only from a z/VM system. For this purpose, you first must generate a file which contains the binary image of the RDEV control blocks of your z/VM system. In a second step, migrate this file into the IODF. (see "Step 4. Migrate Your Operating System from an RDEV List" on page 261).

You may have to complete the definition afterwards in the IODF for the devices that are offline and cannot be sensed by z/VM.

---

## Chapter 11. How to Migrate Existing Input Files

### Overview

This chapter describes how to:

- Prepare the input files before migrating them
- Migrate the input files using the HCD batch utilities
- Replace existing configuration data through migration
- Change I/O configurations by editing files
- Understand and resolve errors that occurred during migration

HCD allows you to migrate existing configuration data that was defined in IOCP and HCPRIO input files to an IODF.

As input, you can use one of the following:

- An IOCP input file
- A file containing RDEV control blocks
- An HCPRIO input file

You can also use the migration to create I/O definitions by editing control statements. Files containing the statements corresponding to a specific IODF can be generated and migrated using the REXX utilities *CBDSCONF* and *CBDSMIGR*, see “Build I/O Configuration Data (CBDSCONF)” on page 140 and “Migrate I/O Configuration Statements (CBDSMIGR)” on page 126.

When migrating from input files, HCD checks the syntax of the input statements and runs a validation process that checks that the definitions being migrated do not conflict with the I/O configuration rules and with existing definitions in the IODF or with other definitions being migrated.

If HCD detects an error in the input files, it issues messages after the migration process has ended.

### Important Note:

It may not be possible to remigrate an IOCP input data set generated by HCD back into the IODF. The reasons are:

- HCD uses the High Level Assembler program for parsing the IOCP control statements. The High Level Assembler earlier than V1.5 is restricted to 255 characters for any keyword value. IOCP statements, however, may contain keywords with a value greater than 255 characters. High Level Assembler V1.5 removes this restriction.
- HCD keeps additional data for a processor configuration that is not contained in an IOCP input data set. This data may be used for validation and, therefore, missing at the migrate step leading to validation errors. For example, the partition usage is defaulted to CF/OS. For a shared CF peer channel, this may lead to a validation error, because only a CF partition may be specified in the access or candidate list.

- Since the IOCP data are only a subset of the processor configuration data, you may lose this additional configuration data if you update a processor configuration from an IOCP input data set.

For updating the IODF via I/O control statements, it is recommended to use the extended I/O configuration statements of HCD instead of an IOCP input data set (see “Build I/O Configuration Statements” on page 88).

---

## Migration Sequence

If you want to migrate more than one input file into a single IODF, comply to the following migration sequence:

1. Migrate all IOCP input files
2. Migrate all HCPRIO input files or RDEV control blocks

---

## Preparing Your Input Files for Migration

Before you can successfully migrate IOCP or HCPRIO input files, you may need to change the input because HCD does a more rigorous checking of the input statements than IOCP.

To ensure that the migration is successful and that the resulting IODF accurately reflects the physical configuration, ensure that your input data sets apply to the validation rules described below. For assistance when checking the definitions in the input statements, you can use the *Supported Hardware Report* “Supported Hardware Report” on page 199.

### Data Requiring Attention

This section details which data may need to be changed and how to change it to ensure a successful migration.

#### Control Unit Types

HCD checks whether a specified control unit type is valid. Review your input for invalid control unit types. If applicable, correct the UNIT parameter of the CNTLUNIT statement.

If you do not want to change the type in your input file, you can edit the HCD profile and specify how a control unit type in the IOCP input data set is mapped to a control unit type in the IODF. Specify one or more of the following keyword:

MAP\_CUTYPE = xxxxx,yyyy-yy

xxxxx

is the control unit type specified in the IOCP input file

yyyy-yy

is the control unit type and model (optional) to be used in the IODF

For more information about the HCD profile, refer to “Defining an HCD Profile” on page 26.

#### Control Unit Models

HCD requires, for certain control unit types, the specification of a model. For example, the IBM 3880 control unit requires a model specification. If a control unit type requires a model specification, and if you do not specify one in the input file, HCD assigns a model to the control unit definitions based on the attached devices and the used control unit protocol. This control unit model is indicated as default

model in the UIM (information message CBDA534I is issued). As processing goes on, it can be necessary to change the default model to another model to support the specified protocol (warning message CBDA536I is issued). Or, the default model is changed to attach a device type which is not supported by the default control unit model (warning message CBDA265I is issued).

**Note:** The sequence of messages is shown in reverse order in the migration log file since the messages are sorted according to decreasing severities. For an example, please see “Errors Detected During Assembly Process” on page 115.

To assign a model to a control unit, change the UNIT parameter of the CNTLUNIT statement in the input file. Append the model number separated by a dash to the control unit type specification. For example:

```
CNTLUNIT ...,UNIT=3880-23
```

To avoid changing the input files, you can also add a model number by using the MAP\_CUTYPE parameter in the HCD profile as described under “Control Unit Types” on page 80.

## Protocol Support for Control Units

HCD checks the protocols supported by a control unit type. For example, in the source you may have an IBM 3745 with protocol S specified as control unit type 3705. The IOCP program does not check the protocol S specification. To be accepted by HCD as valid input, you have to change the control unit type to 3745.

## Device Types

**For IOCP Input Files:** HCD checks the device types for validity and that they can be attached to the specified control unit. Check your IODEVICE statements in the IOCP input file and make sure that the device types are valid and reflect the true physical device they are defining. A common error, for example, is the IBM 3745 device type defined as 3705.

**For OS Input Files:** HCD supports device types that previously had to be defined as “look-alike” devices for VM. For example, you can define an IBM 6262 printer device (previously defined as an IBM 4248 printer device in the HCPRIO input data set) with a device type of 6262.

The device type support for VM has been brought into line with the MVS™ type support. However, there might be some differences to HCPRIO device type support (for example, concerning the MODEL parameter).

## Assembler Statements

HCD generates own macro instructions into the logical input file before processing. This may cause problems with assembler statements you inserted into your input files. For example, coding the ISEQ, CSECT, or RMODE instructions may cause a warning message issued by the assembler. As a consequence the migration will be terminated. To avoid this, remove your assembler statements. The generated HCD instructions look as follows:

```
        PRINT OFF
        COPY CBDZPARS
        TITLE 'xxx LISTING'
CBDTXT CSECT
CBDTXT RMODE ANY
        PRINT ON NOGEN
        .
        .
input file statements
```



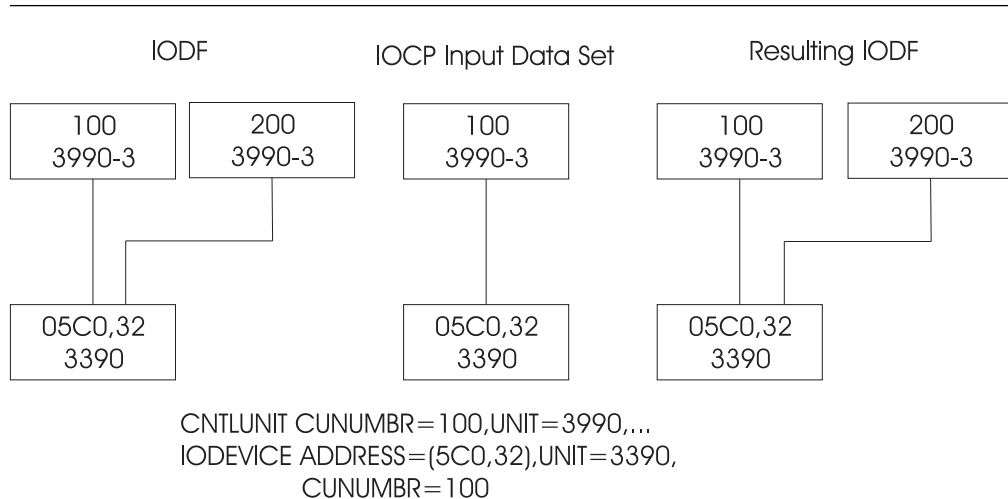

*Figure 18. IOCP Migration.* Control units and devices are mapped, although the devices also attached to another control unit in the IODF.

The following example shows the same control units in the IODF and IOCP input file, but the attached devices are shared in the IOCP input data set. In this case, the devices are merged and will be shared after the migration (only if the control units do not connect to the same processor configuration).

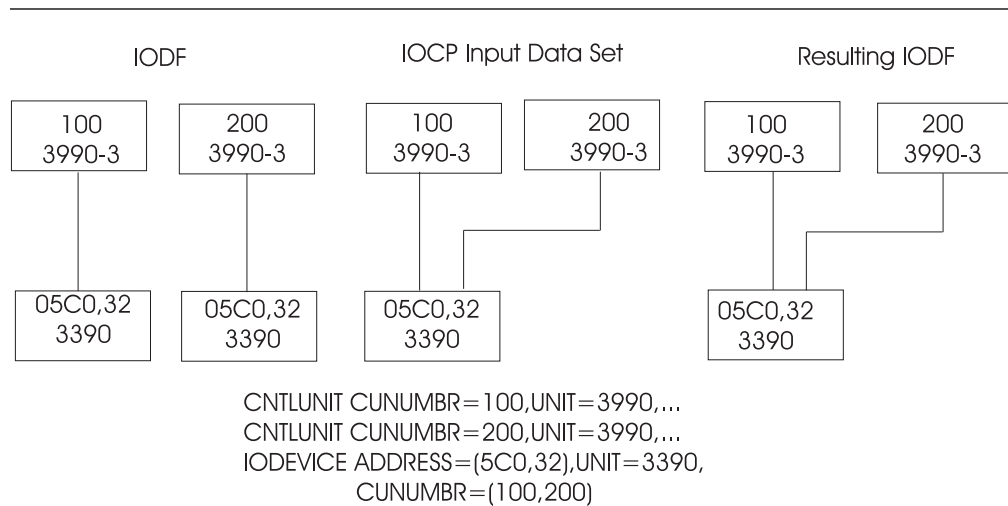

*Figure 19. IOCP Migration.* Control units and devices are mapped (only if the control units do not connect to the same processor configuration).

**The same control unit number is not yet defined in the IODF:** In this case:

- A new control unit is defined.
- A new device is defined, unless one of these conditions is fulfilled:
  - The device in the input file is attached to a control unit, to which it is already attached in the IODF. In this case, the new device is mapped to the existing one and attached to both control units (see Figure 20 on page 84).
  - A device with same device number and type already exists in the IODF and is not attached to any control unit. In this case, the new device is mapped to the existing one and attached to the new control unit (see Figure 21 on page 84).

If none of these conditions is fulfilled, a new device is defined (see Figure 22 on page 85).

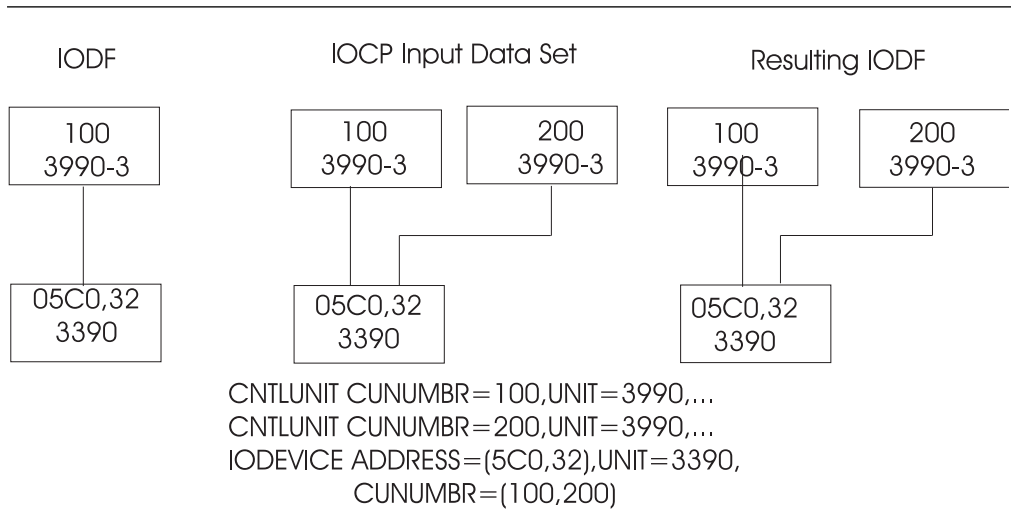

Figure 20. IOCP Migration. Devices are mapped, because one attached control unit is already defined in the IODF.

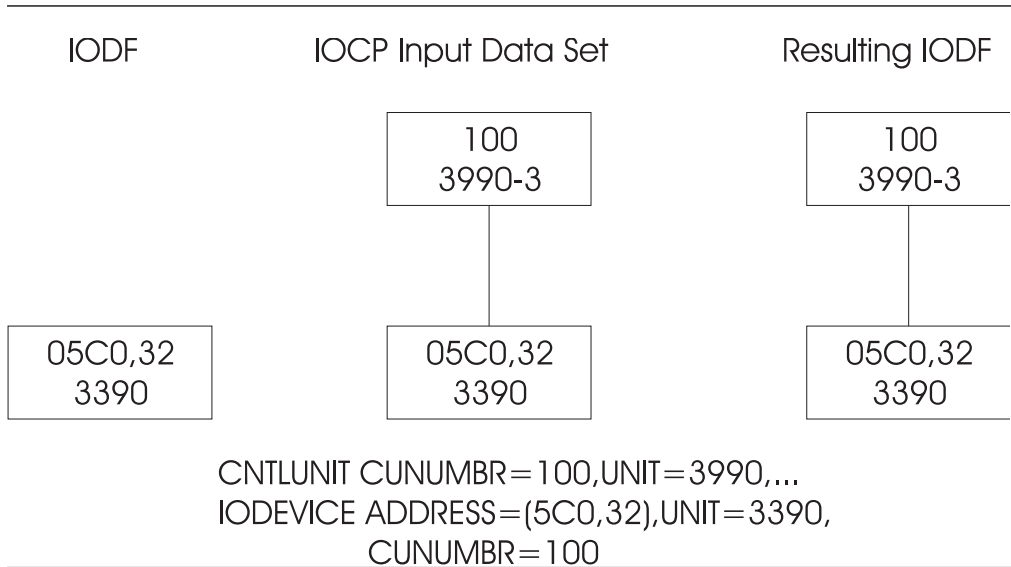

Figure 21. IOCP Migration. Devices are mapped, because the attached control unit is not yet defined in the IODF.

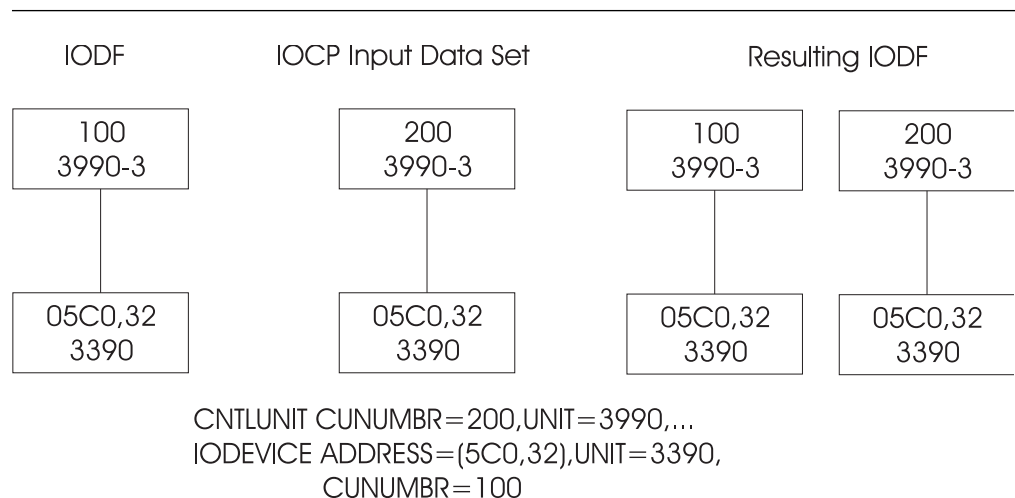

Figure 22. IOCP Migration. Devices are not mapped, because the control unit number does not exist in the IODF.

### Migrating Additional OS Input Files

A device can only be mapped if the device number and device type are the same. If the device number or type is not the same, a new device is defined.

If the device number and type are the same, HCD maps the device according to the following rules:

1. If you specify an associated processor and partition on the *CBDSMIGR* migration utility, HCD maps the new device to a device with the same device number and type connected to this processor and partition (provided that such a device exists).
2. If the new device is not attached to a control unit, the device is mapped to the first device found with the same device number and type.

If the IODF contains several devices with the same device number and type, the device of the OS input file can be erroneously mapped to a wrong device. To avoid this, you can specify the associated processor and partition on the *CBDSMIGR* REXX utility.

**Note:** This is only supported if the migrating OS configuration decks were created with the *CBDSCONF* REXX utility. If they were created using the *CBDSRDEV* REXX utility, then you must manually check and fix (if needed) the OS assignments of the devices with HCM.

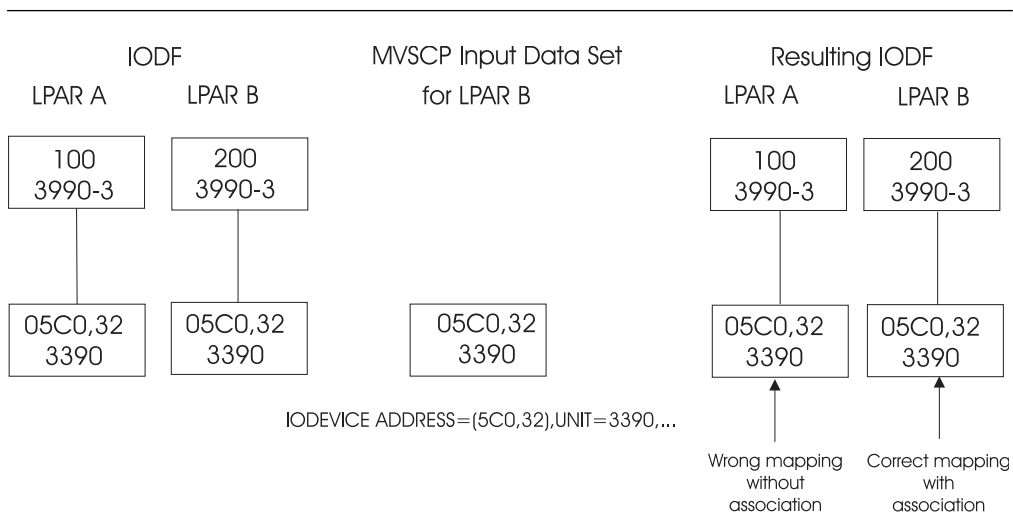

Figure 23. OS Migration. Devices are mapped to the first devices found with the same type and number.

If only a subset of devices in the input file is already defined in the IODF, this subset is mapped to the existing devices and the remaining new definitions are added.

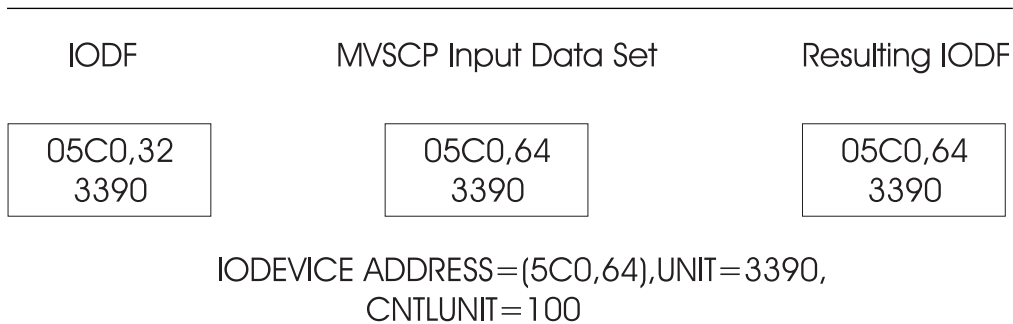

Figure 24. OS Migration. 32 devices are mapped, the other 32 devices are newly defined.

## Migrating Input Files Using a REXX Utility

The following steps explain how to migrate your input files using a REXX utility.

### Step 1: Create the Work IODF

If an IODF does not yet exist, you first have to create a work IODF into which you want to migrate your IOCP or OS files. Refer to “Create and Initialize an IODF (CBDSIODF)” on page 123 on how to create and initialize an IODF.

### Step 2: Migrate Input File

The EXEC **CBDSMIGR** allows to migrate an IOCP file or a VM input file (HCPRIO input file or file containing RDEV control block information) to an existing work IODF.

You find more information about this REXX utility with the complete invocation syntax and some invocation examples in “Migrate I/O Configuration Statements (CBDSMIGR)” on page 126.

### Step 3: Analyze Errors and Upgrade the Input File

During the migration process, HCD first invokes the assembler that parses the input statements. If it detects an error, the migration process is terminated.

- HCD writes a message to the file allocated by HCDMLOG that the migration completed with return code RC=12.
- HCD writes a message to the HCD migration log (HCDPRINT) indicating that the assembler completed with a return code other than zero.
- The assembler writes information to the assembly listing (HCDASMP) that describes the problem in more detail.

If the assembler does not detect any errors, HCD runs a validation check. If it detects an error:

- HCD writes a message to the file allocated by HCDMLOG that the migration completed with return code higher than 4.
- HCD writes error messages to the HCD migration log (HCDPRINT) describing the validation problem.

If the return code is 0 or 4, the IODF is updated. It is, however, recommended that you review the migration log. HCD may have made assumptions that are contrary to your configuration requirements. Your actions:

1. Review the migration log. For explanations and examples refer to “Errors Detected During Validation Process” on page 116.
2. Edit and correct the IOCP and OS input files.
3. Migrate your input files again.

### Step 4: Build Production IODF

Before you can use the IODF to IPL your operating system you have to convert the work IODF into a production IODF. Refer to “Build a Production IODF (CBDSPROD)” on page 133 for an example on how to build a production IODF using the work IODF.

---

## Changing I/O Configurations by Editing Files

With HCD, the extended migration function and the added possibilities for writing and migrating configurations allow defining or changing configuration definitions without using HCM.

It is possible to define all configuration objects with their attributes and their connections in I/O configuration statements with IOCP/HCPRIO like syntax, in a file used as input to the REXX utility *CBDSMIGR*. For example, a switch together with its ports can be defined via this method.

With the REXX utility *CBDSCONF*, it is also possible to recreate files containing I/O configuration statements for the processor, operating system and switch configurations from an IODF.

However, for some tasks, such as deleting certain configuration objects, it is necessary or easier to make the configuration changes directly in HCM. For more details on the capabilities of the migration function refer to the table in Table 6 on page 107.

#### Processor configurations

The migrate IOCP function is extended to allow the specification of parameters, additional to IOCP, in the input file. Analogously, when

building an IOCP input file from the IODF, information is generated which describes the additional parameters of the configuration objects. Processor configuration files can be built using the *CBDSIOCP* REXX utility or the *CBDSCONF* REXX utility.

#### **Operating system configurations**

The migrate HCPRIO function is extended to allow the specification of all configuration data of an OS configuration. Also, it is possible to generate an OS configuration file from the IODF using the *CBDSCONF* REXX utility. For details, refer to “Build I/O Configuration Statements.”

#### **Switch configurations and switch-to-switch connections**

It is possible to migrate switch definitions with all ports, switch-to-switch connections and all switch configurations from a file. Analogously, it is possible to build such a file from the IODF using the *CBDSCONF* REXX utility.

## **Build I/O Configuration Statements**

The REXX utility *CBDSCONF* allows you to generate an output file from a production IODF or a work IODF containing I/O configuration statements. With *CBDSCONF*, you can export the internal IODF format to I/O configuration statements, edit them and later re-import them to the HCD IODF format with the REXX utility *CBDSMIGR*.

How to invoke this utility is described in “Build I/O Configuration Data (CBDSCONF)” on page 140.

## **Additional Parameters and Statements**

In the following, the configuration objects and their attributes you can define via I/O control statements and migrate into HCD are described. For a detailed description of the IOCP keywords and parameters, refer to the *IOCP User's Guide* that is appropriate for your processor.

#### **Operating system**

- ID
- Name
- Type
- Description
- D/R site OS configuration

#### **Switch**

- ID
- Unit
- Model
- Description
- Serial number
- Installed ports
- Chained switch connection

#### **Port**

- Address
- Name
- Occupied indication

#### **Switch configuration**

- ID
- Switch ID
- Description
- Default dynamic connection

<b>Port configuration</b>	<ul style="list-style-type: none"> <li>ID</li> <li>Allowed dynamic connections</li> <li>Prohibited dynamic connections</li> <li>Dedicated connection</li> <li>Blocked indication</li> </ul>
<b>Processor</b>	<ul style="list-style-type: none"> <li>ID</li> <li>Unit</li> <li>Model</li> <li>Support level</li> <li>Configuration mode</li> <li>SNA address</li> <li>Serial number</li> <li>Description</li> </ul>
<b>Channel Subsystem</b>	<ul style="list-style-type: none"> <li>ID</li> <li>Description</li> <li>Maximum number of devices</li> </ul>
<b>Partition</b>	<ul style="list-style-type: none"> <li>Name</li> <li>Number</li> <li>Usage</li> <li>Description</li> </ul>
<b>PCIe function</b>	<ul style="list-style-type: none"> <li>ID</li> <li>Unit</li> <li>Type</li> <li>CHID (PCHID, VCHID)</li> <li>Virtual function number</li> <li>Description</li> <li>PNET IDs</li> <li>Partition access list</li> <li>Partition candidate list</li> </ul>
<b>Channel path</b>	<ul style="list-style-type: none"> <li>ID</li> <li>Type</li> <li>Operation mode</li> <li>Adapter details (PCHID, VCHID, HCA)</li> <li>PNET IDs</li> <li>Partition access list</li> <li>Partition candidate list</li> <li>Channel parameter</li> <li>I/O cluster</li> <li>Dynamic switch</li> <li>Description</li> <li>Coupling facility (CF) connection information</li> <li>Entry switch/port connected to a channel path</li> <li>Physical network ID</li> </ul>

**Control unit**

Number  
 Unit  
 Model  
 Serial number  
 Switch/port connected to a control unit  
 Description  
 Connected channel paths/link addresses  
 Unit address ranges  
 I/O concurrency level  
 Protocol  
 Logical address

**Device**

Number  
 Unit  
 Model  
 Serial number  
 Volume serial number  
 Connected control units  
 Description  
 Unit address  
 Preferred channel path  
 TIMEOUT indication  
 Status detection indication  
 OS parameters/features

**Operating System**

An operating system is specified with the IOCONFIG statement. It contains the following parameters:

- ID** Specifies the numerical identifier of the OS (mandatory).
- TYPE** Specifies the OS configuration type. This is required only, if the migration is performed using the wildcard \* in the parameter string of the batch utility. Otherwise, it is ignored and the OS configuration type is taken from the invocation parameters.
- NAME** Specifies the OS configuration ID. This is required only, if the migration is performed using the wildcard \* in the parameter string of the migrate utility. Otherwise, it is ignored and the OS configuration ID is taken from the invocation parameters.
- DESC** Specifies a description of the operating system (optional). The description of the OS configuration is added or updated.
- DROSID** Specifies the alphanumeric identifier of the D/R site OS configuration (optional). Note that an OS configuration for the D/R site can only be specified for MVS-type OS configurations.

**Syntax:**

ID=id	2 alphanumeric characters
NAME=os_name	up to 8 alphanumeric characters
TYPE=type	MVS or VM
DESC='description'	up to 32 characters
DROSID=os_name	up to 8 alphanumeric characters

**Example:** The following example defines an OS configuration named NEWOS01B of type MVS together with the given description.

```
IOCONFIG ID=01,NAME=NEWOS01B,DESC='LPAR system',TYPE=MVS,DROSID=NEWOSDR1
```

## Switch

A switch is specified with the SWITCH statement. It contains the following parameters:

**SWID** Specifies an identifier for the switch (mandatory).

**UNIT** Specifies the switch unit (mandatory).

### MODEL

Specifies the switch model (optional).

**DESC** Specifies a description of the switch (optional).

### SERIAL

Specifies a serial number (optional).

**PORT** Specifies the installed ports (default from UIM, optional).

Specify only ports that are supported by the switch type. At least the minimum installed port range is set to installed. If the switch already exists with an installed port range that differs from the specified installed port range(s), only the new specified ports are set to installed if possible. That means, any existing installed port that does not hold a connection to a channel path or control unit is set to not installed if not specified with the PORT parameter.

### SWPORT

Specifies the chained switch connections (optional). If operand exceeds 255 characters, repeat the SWITCH statement with the remaining values.

If the switch already exists, all existing connections to other switches are broken. The connections to other switches are established as specified by the SWPORT parameter.

### ADDRESS

Specifies the switch address for a FICON switch (optional).

The corresponding switch control unit and device are specified by corresponding CNTLUNIT and IODEVICE statements.

## Syntax:

SWID=id	2 hexadecimal characters
UNIT=switch_unit	like CU type
MODEL=switch_model	like CU model
DESC='description'	up to 32 characters
SERIAL=serial_no	up to 10 characters
PORT=((low_port_id,high_port_id),...)	up to 8 port ranges
SWPORT=((from_port,to_switch,to_port),...)	up to 8 switch-to-switch connections

**Example:** In the following example, switch 02 with an installed port range 80 to FB is chained to port D1 of switch 01 via port C0.

```

SWITCH SWID=02,UNIT=9032,MODEL=3,          *
      PORT=((80,FB)),                       *
      DESC='Aspen switch, installed 10/09/94', *
      SERIAL=55-8888,                       *
      SWPORT=(C0,01,D1)

```

**Note:** Put the serial numbers in quotes, if you use characters such as blanks or commas as part of your serial numbers.

## Port

A switch port is specified with the PORT statement. It contains the following keywords:

**ID** Port address identifying the port (mandatory).

### NAME

Specifies a port name (optional).

To be accepted within I/O Operations (ESCON Manager) commands the port name must not include commas, asterisks, or blanks. It must not contain X'FF' or any extended binary-coded decimal interchange code (EBCDIC) character less than X'40'. It must also not begin with a left parenthesis and end with a right parenthesis.

**OCC** Indicates that the port has an external connection (optional).

*External* means a connection to a processor, switch, or control unit.

### Syntax:

ID=port_id	2 hexadecimal characters
PORTNM='portname'	up to 24 characters
OCC	no value assigned

**Example:** In the following example port D5 is named 'connected\_to\_CU\_7230' and indicated as occupied.

```

PORT ID=D5,          *
      PORTNM='connected_to_CU_7230', *
      OCC

```

## Switch Configuration

A switch configuration is specified with the SWCONF statement. It contains the following parameters:

**ID** Specifies the switch configuration ID (mandatory).

**SWID** Identifies the switch owning the configuration (mandatory).

**DESC** Specifies a description of the switch configuration (optional).

### DEFCONN

Specifies whether the default port connections are set to allowed or prohibited (mandatory).

### Syntax:

ID=switch_configuration_id	8 characters
SWID=switch_id	2 hexadecimal characters
DESC='description'	up to 32 characters
DEFCONN=dynamic_default_connection	A (allowed) or P (prohibited)

**Example:** In the following example the default connection for switch configuration BASECONF of switch 01 is set to allowed.

```
SWCONF ID=BASECONF,          *
      SWID=01,                *
      DESC='basic configuration', *
      DEFCONN=A
```

## Port Configuration

A port configuration is specified with the POCONF statement.

The POCONF statement is an optional extension to the switch configuration. With POCONF, port connections are defined explicitly and existing defaults are overridden. In all, the statement may be a maximum of 255 characters long. To express longer statements the POCONF may be repeated. POCONF includes the following parameters:

**ID** Port address identifying the port (mandatory).

### PORTCF

Specifies the type of connections to target ports (mandatory).

In the PORTCF operand

**A** sets the dynamic connection to the succeeding list of target port IDs to allowed

**P** sets the dynamic connection to the succeeding list of target port IDs to prohibited

**D** sets a dedicated connection to the succeeding target port ID

### BLOCKED

blocks the port

### Syntax:

ID=port_id	2 hexadecimal characters
PORTCF=(A,(id1,...,idn),	list of ports in installed range (connection allowed)
P,(id1,...,idm),	list of ports in installed range (connection prohibited)
D,(id),	port with dedicated connection
BLOCKED)	BLOCKED attribute

**Example:** In the following example port D2 has allowed dynamic connections to ports B1 and B3, and prohibited dynamic connections to B5 and B7. Port D4 has a dedicated connection to port C0.

```
POCONF ID=D2,          *
      PORTCF=(A,(B1,B3),P,(B5,B7))
POCONF ID=D4,          *
      PORTCF=(D,(C0))
```

## Processor

A processor is specified with the ID statement. If specified, it must precede all other statements in the configuration file. It contains the following keywords:

### NAME

Specifies the processor ID. If the ID does not exist, it is created (1).

**MSG1** Specifies the identification information that is printed on the ID1 line of the heading in IOCP configuration reports (optional). Only supported for compatibility with IOCP.

**MSG2** Specifies the identification information that is printed on the ID2 line of the heading in IOCP configuration reports (optional). Only supported for compatibility with IOCP.

**SYSTEM**

Specifies the machine limits and rules that IOCP will enforce for a deck verification. The system parameter includes a specification of the processor machine type number and, optionally, a machine limits number (optional). Only supported for compatibility with IOCP.

**LSYSTEM**

Specifies the system name (CPC designator) of the local system (the system which uses this IOCDs).

**UNIT** Specifies the processor unit (1).

**MODEL**

Specifies the processor model (1).

**LEVEL**

Specifies the processor support level (1). For further information on support levels refer to 'support\_level\_ID'.

**MODE**

Specifies the processor configuration mode – which must be LPAR (1).

**SNAADDR**

Specifies the SNA address (network name, system name) for a processor in an S/390 microprocessor cluster (optional).

**SERIAL**

Specifies the processor serial number (optional).

**DESC** Specifies a description for the processor (optional).

**Note (1):** Processed only if the migration is performed using the wildcard \* in the parameter string of the batch utility.

**Syntax:**

NAME=processor_id	8 characters
MSG1='message'	up to 64 characters; first 8 characters are taken as IOCDs name
MSG2='message'	up to 64 characters
SYSTEM=(processor_unit[,limits_number])	4 characters followed by a decimal number
UNIT=processor_unit	8 characters
MODEL=processor_model	4 characters
LEVEL=support_level	8 characters
LSYSTEM=local_cpc_designator	8 characters
SNAADDR=(network_name,system_name)	list of 2 entries, each up to 8 characters
MODE=processor_mode	LPAR
SERIAL=serial_number	up to 10 characters
DESC='description'	up to 32 characters

**Example:** In the following example processor PROC01 of type 2094, model S28 is defined with the serial number 0518712094, in LPAR mode (a required choice), at support level H050331.

```
ID NAME=PROC01,UNIT=2094,MODEL=S28,          *
DESC='XMP, Basic 2094 support',SERIAL=0518712094, *
MODE=LPAR,LEVEL=H050331
```

## Channel Subsystem and Partition

Depending on whether you use the RESOURCE statement for XMP processors or SMP processors, it specifies the channel subsystems, the logical partitions (names and numbers) and groups the logical partitions to the channel subsystems. It contains the following keywords:

### PART or PARTITION

Specifies a list of partition names with an optional addition of the corresponding partition numbers (mandatory).

### DESCL

Specifies a list containing descriptions for the defined partitions (optional).

### USAGE

Specifies a list describing the partition usage type for each partition.

### MAXDEV

Specifies the maximum number of devices in each subchannel set.

### CSSDESCL

Specifies a list of channel subsystem descriptions, one list entry for each channel subsystem listed in the MAXDEV keyword.

**Note:** If the partition type is missing, it is set automatically depending on which types of channel paths are assigned to the partition and the capability of the processor.

### Syntax:

#### For XMP processors:

```
PART[ITION]=
((CSS(0),(lpname[,lnumber])[,(lpname[,lnumber])...])
...
[, (CSS(n),(lpname[,lnumber])[,(lpname[,lnumber])...])])
)
```

lpname: up to 8 alphanumeric characters for the LPAR name; for XMP processors, an \* is accepted as lpname to indicate a reserved partition;

#### For SMP processors:

```
PART[ITION]=
((lpname[,lnumber])[,(lpname[,lnumber])...])
```

lnumber: 1 hexadecimal character for the LPAR number.  
The CSS(n) parameter(s) must be used for XMP processors and must not be used for SMP processors.

```
DESCL=('descp1_css0','descp2_css0',...,
      'descp1_css1','descp2_css1',...,
      ...
      'descp1_cssn','descp2_cssn',...)
```

description for all partitions in the processor complex, up to 32 characters per description

```
CSSDESCL=('desc_css0','desc_css1',...)
```

description syntax of channel subsystems for XMP processors

```
USAGE=(usage1_css0,usage2_css0,...,
      usage1_css1,usage2_css1,...,
      ...
      usage1_cssn,usage2_cssn,...)
```

usage of each partition in the processor complex (CF, OS, or CF/OS)

```
MAXDEV=((CSS(0),maxnum1[,maxnum2, maxnum3]),...,
      (CSS(n),maxnum1[,maxnum2, maxnum3]))
```

maximum number of devices for each channel subsystem and each subchannel set

**Example for an SMP processor:** In the following example, partitions LP1, LP2, and CF1 are defined and described.

```
RESOURCE PART=((LP1,1),(LP2,2),(CF1,3)), *
            DESCL=('Logical Partition 1', *
                  'System 3', *
                  'Coupling Facility'), *
            USAGE=(CF/OS,OS,CF)
```

**Example for an XMP processor:** In the following example, the XMP processor contains three channel subsystems with three partitions in each.

```
RESOURCE PART=((CSS(0),(LP01,1),(LP02,2),(LP03,3)), *
              (CSS(1),(LP11,1),(LP12,2),(LP13,3)), *
              (CSS(2),(LP21,1),(LP22,2),(LP23,3))), *
            DESCL=('LPAR1_of_CSS0','LPAR2_of_CSS0','LPAR3_of_CSS0', *
                  'LPAR1_of_CSS1','LPAR2_of_CSS1','LPAR3_of_CSS1', *
                  'LPAR1_of_CSS2','LPAR2_of_CSS2','LPAR3_of_CSS2'), *
            USAGE=(CF/OS,OS,CF,CF/OS,OS,CF,CF/OS,OS,CF), *
            MAXDEV=((CSS(0),63),(CSS(1),50),(CSS(2),35)), *
            CSSDESCL=('first CSS(0)','second CSS(1)','third CSS(2)')
```

For HCD, it is also possible to specify a separate RESOURCE statement for each channel subsystem. This may be required if you do not use a High Level Assembler V1.5 or later. You can split the previous RESOURCE example for an XMP processor into the following parts:

```
RESOURCE PART=((CSS(0),(LP01,1),(LP02,2),(LP03,3))), *
            DESCL=('LPAR1_of_CSS0','LPAR2_of_CSS0','LPAR3_of_CSS0'), *
            USAGE=(CF/OS,OS,CF), *
            MAXDEV=(CSS(0),63), *
            CSSDESCL=('first CSS(0)')
RESOURCE PART=((CSS(1),(LP11,1),(LP12,2),(LP13,3))), *
            DESCL=('LPAR1_of_CSS1','LPAR2_of_CSS1','LPAR3_of_CSS1'), *
            USAGE=(CF/OS,OS,CF), *
            MAXDEV=(CSS(1),50), *
            CSSDESCL=('second CSS(1)')
RESOURCE PART=((CSS(2),(LP21,1),(LP22,2),(LP23,3))), *
            DESCL=('LPAR1_of_CSS2','LPAR2_of_CSS2','LPAR3_of_CSS2'), *
            USAGE=(CF/OS,OS,CF), *
            MAXDEV=(CSS(2),35,20), *
            CSSDESCL=('third CSS(2)')
```

## PCIe Function

A PCIe function is specified with the FUNCTION statement. It contains the following keywords:

**FID** specifies the PCIe function number (mandatory).

### PCHID

| identifies the PCIe adapter card which provides the specified function by  
| specifying the slot of the card in the I/O drawer - exclusive to the VCHID  
| keyword (one of PCHID or VCHID must be specified).

### VCHID

| specifies a virtual channel identifier (optional). Used for internal PCIe  
| function - exclusive to the PCHID keyword (one of PCHID or VCHID  
| must be specified).

**VF** specifies the PCIe virtual function number (optional).

**PART** specifies one partition for the access list followed by partitions for the candidate list (mandatory).

**PNETID**

specifies the physical-network-IDs (up to 4). These are valid only for ROCE (optional).

**UNIT** specifies the PCIe function type (optional – support for backward compatibility).

**TYPE** specifies the PCIe function type (optional – if it is not specified, it will default to ROCE).

**DESC** specifies a description of the PCIe function (optional).

**Syntax:**

FID=xxxx	Four hexadecimal characters.
TYPE=type	Valid PCIe function type - ZEDC, ROCE, ISM, or RCE. (Note: ZEDC-EXPRESS is also accepted as an alias.)
UNIT=type	PCIe function type (used to be backward compatible).
PCHID=xxx	Three hexadecimal characters.
VF=nnn	Up to three decimal digits.
VCHID=xxx	Three hexadecimal characters for the virtual channel ID.
PNETID=(pnetid1,...,pnetid4)	Up to four 16-character alphanumeric physical network IDs.
PART=(acc_lp1 [(,cand_lp1[,...,cand_lpn]]])	Access list (limited to one partition) and optional candidate list of partitions connected to the PCIe function.
DESC='PCIe function description'	Up to 32 characters.

**Examples:**

In the following example, PCIe Function is defined for type ROCE:

```
FUNCTION FID=020, VF=31, PART=((LP01), (LP11, LP14, LP41, LP46)), *
        TYPE=ROCE, DESC='max VF and 2 pnetids', *
        PNETID=(PNETID1, PNETID2, ,), PCHID=4FE
```

In the following example, PCIe Function 51 is defined for a ZEDC-EXPRESS card associated with a physical channel ID 4FF, with partition LP02 initially accessing the function.

```
FUNCTION FID=051, VF=4, PART=((LP02), (LP01, LP41, LP46, OS51)), *
        TYPE=ZEDC-EXPRESS, DESC='second zdec', PCHID=4FF
```

**Channel Path**

A channel path is specified with the CHPID statement. For an XMP processor, a spanned CHPID is defined for one or more channel subsystems. Therefore, the CHPID statement must contain channel subsystem data. If only one CSS is defined, it is not required to specify it on the PATH keyword.

The CHPID statement contains the following keywords:

**PATH** Specifies the CHPID number and, if required, the CSS IDs of the channel path (mandatory).

**TYPE** Specifies the channel path type of I/O operation for the channel path (mandatory).

**SHARED**

Specifies that the channel path on the CHPID statement is shared (optional).

**REC** Specifies that the channel path on the CHPID statement is reconfigurable (optional).

**PART, PARTITION, or NOTPART**

**PART** and **PARTITION** specify the access list of logical partitions that will have the channel path configured online after POR, and the candidate list identifying the logical partitions which can access the device.

**NOTPART** specifies the access list of logical partitions that will not have the channel path configured online after POR, and the list of logical partitions which cannot access the device.

**REC** **REC** in the **PART** or **PARTITION** keyword allows the channel path to be dynamically moved between partitions after POR.

**CHPARM,OS**

Specifies channel path data that is used by the operating system.

Examples:

1. **CHPARM=00** is the default.
2. **CHPARM=01** indicates that the channel path is managed by DCM.
3. **CHPARM=02** indicates the following:
  - For IQD channels: the channel can access the IEDN (IQDX function)
  - For OSD, OSM, and OSX channels: priority queuing is disabled.
4. **CHPARM=40** indicates that the maximum frame size for an IQD channel is 24K.

Note that for OSM channel paths, device priority queuing needs to be disabled. Therefore, for these CHPIDs, HCD converts a **CHPARM=00** (default with priority queuing enabled) to **CHPARM=02**.

For more information on the **CHPARM** parameter, refer to the *IOCP User's Guide* for your processor.

**I/O CLUSTER**

Specifies an I/O cluster name. An I/O cluster is a sysplex that owns a managed channel path for an LPAR processor configuration.

**SWITCH**

Specifies a number for a switch (ESCON Director) which is used as a dynamic switch for all paths from the channel path (CHPID) to the connected control units (required for dynamic connections through a switch).

**DESC** Specifies a description of the channel path (optional).

**TPATH**

Specifies a connected CF channel path (optional).

The **TPATH** parameter can be specified for a CF channel path, either CF receiver, CF sender, or CF peer channel path.

For a CF sender or CF receiver channel path, the **TPATH** parameter must contain:

- the target processor
- the target CSS ID for XMP processors

- the target channel path ID

When specified with a CF sender channel path id, the TPATH parameter must also contain:

- the CF sender control unit and device numbers used for the CF connection. This information is optional for a CF receiver channel path.

For a CF peer channel path, the TPATH parameter contains the following items for the target and source channel paths of the CF connection:

- target processor name
- the target CSS ID for XMP processors
- target channel path ID
- control unit number (only if this is a sending CF channel, i.e., the channel path connects to a target CF logical partition)
- starting device number (only if this is a sending CF channel)

A CF connection uses two (CF sender channel) or seven (sending CF peer channel) devices. Only the starting one can be specified (with four digits). The remaining devices are automatically assigned to the next consecutive device numbers.

Any CF control units and CF devices specified via CNTLUNIT and IODEVICE statements are ignored.

The connection can only be established if the target channel path exists. If the target channel path is already connected, the existing connection is broken and a new connection is established.

#### **SWPORT**

Specifies an entry switch port (optional).

#### **PCHID**

Specifies a physical channel identifier (optional).

#### **VCHID**

Specifies a virtual channel identifier (optional). Used for internal channel path - exclusive to the PCHID keyword.

**AID** Specifies the ID of the host communication adapter (HCA) on which the channel is defined.

**PORT** Specifies the port on the HCA on which the channel is defined.

#### **PNETID**

Specifies the physical-network-IDs (up to 4). It can only be specified with OSD and IQD CHPIDs (optional).

#### **Syntax:**

PATH=[(CSS(n,...),]chpid_number[]]	2 hexadecimal characters
TYPE=type	valid channel path type
SHARED	no value assigned
REC	no value assigned

**For XMP processors:**

```
PART[ITION]=((CSS(0),(acc_1p1,...,acc_1pn)
              [, (cand_1p1,...,cand_1p2)] [,REC])
            ...
            [(CSS(n),(acc_1p1,...,acc_1pn)
              [, (cand_1p1,...,cand_1p2)] [,REC])])
            )
```

access list and optional candidate list of partitions; optional addition of REC; for XMP processors: CSS ID is required

**For SMP processors:**

```
PART[ITION]=((acc_1p1,...,acc_1pn)
              [, (cand_1p1,...,cand_1p2)] [,REC]
            )
```

**For XMP processors:**

```
NOTPART=((CSS(0),(acc_1p1,...,acc_1pn)
          [, (cand_1p1,...,cand_1p2)])
        ...
        [(CSS(n),(acc_1p1,...,acc_1pn)
          [, (cand_1p1,...,cand_1p2)])])
        )
```

up to 2 lists of partitions

**For SMP processors:**

```
NOTPART=((acc_1p1,...,acc_1pn)
          [, (cand_1p1,...,cand_1p2)]
        )
```

OS=xx, CHPARAM=xx

2 hex character OS parameter

IOCLUSTER=sysplex

8 character sysplex name for managed CHPID

SWITCH=xx

2 hexadecimal characters

DESC='description'

up to 32 characters

TPATH=(proc,chpid[,CFS CU,CFS device])  
(for legacy CF channel path only)

target CHPID for connected CHPID pairs (CF connection):  
8 character processor name  
2 hex character CHPID  
4 hex character CU number  
4 hex character device number

TPATH=((proc,chpid[,CFP CU,CFP device]),  
(proc,chpid[,CFP CU,CFP device]))  
(for CF peer channel path only)

pair of target and source CHPIDs (CF peer connection):  
8 character processor name  
2 hex character CHPID  
4 hex character CU number  
4 hex character device number

TPATH=((CSS(n),proc,chpid[,cu,device]),...)

for XMP processors

SWPORT=(swid,port)

switch and port to which the CHPID connects

PCHID=xxx

three hexadecimal characters for the physical channel ID

VCHID=xxx

three hexadecimal characters for the virtual channel ID

AID=xx

two hexadecimal characters

PORT=n

one numeric character

PNETID=(physical-network-ID-1[,physical-network-ID-2])

up to four 16-character alphanumeric physical network ID names

**Example:** In the following example channel path 35 of type CNC is connected to port FB of switch 03, which is used as a dynamic switch. Channel path 35 is defined as shared with all partitions of the processor in its access list.

Channel path 10 of type CFS, defined to partition LP4, is connected to CFR channel 11 of processor PROC1 using control unit FFFE and devices FFF0,2 for the coupling facility connection.

Channel path 12 of type CFR, defined as dedicated to partition C1, is connected to CF sender channel 70 of processor PROC2. (The used coupling facility devices and control units are defined with CHPID 70 of processor PROC2.)

```
CHPID PATH=(35),SWITCH=03,TYPE=CNC,          *
      SWPORT=(03,FB),SHARED,                 *
      DESC='Chpid connected to switch'
CHPID PATH=(10),TYPE=CFS,PART=((LP4),(LP4)),   *
      TPATH=(PROC1,11,FFFE,FFF0)
CHPID PATH=(12),TYPE=CFR,PART=((C1),(C1)),    *
      TPATH=(PROC2,70)
```

**Example for an XMP processor:** In the following example, the spanned channel path 33 of type IQD is shared by partitions between channel subsystems 0 and 1.

```
CHPID PATH=(CSS(0,1),33),                    *
      TYPE=IQD,                               *
      PART=((CSS(0),(LP01,LP02)),            *
            (CSS(1),(LP11,LP12)))
```

## Control Unit

A control unit is specified with the CNTLUNIT statement. It contains the following keywords:

### CUNUMBR

Specifies a number assigned to the control unit (mandatory). The number assigned to each control unit must be unique within an IODF.

**UNIT** Specifies the type of control unit (mandatory).

### SERIAL

Specifies a serial number (optional).

### SWPORT

Specifies switch ports to which the control unit is connected (optional). If operand exceeds 255 characters, repeat the CNTLUNIT statement with the remaining values.

**DESC** Specifies a description of the control unit (optional).

**PATH** For each channel subsystem, this keyword specifies the channel paths attached to the control unit (mandatory). For control units that are not connected to a processor, specify PATH=\*\* or PATH=(\*\*).

**LINK** For each channel subsystem, this keyword specifies the link address to which the control unit is attached (optional).

The order in which the link addresses are specified corresponds to the order in which the channel paths are specified in the PATH keyword.

### UNITADD

Specifies the unit address ranges that are recognized by the control unit (mandatory).

### CUADD

Specifies the logical address for the control unit (optional).

### SHARED

Specifies the level of concurrency of I/O requests that the parallel channel path allows for the control unit (optional).

## PROTOCOL

Specifies the interface protocol that the parallel control unit uses when operating with the channel paths specified in the PATH keyword (optional).

### Syntax:

#### Syntax:

CUNUMBR=number	4 hexadecimal characters
UNIT=type	valid control unit type
SERIAL=serial_number	up to 10 characters
SWPORT=((swid1,port1),(swid2,port2),...)	list of up to 32 sublists (switch ID, port ID) 2 hex character switch ID 2 hex character port ID
DESC='description'	up to 32 characters max.
<b>For XMP processors:</b> PATH=((CSS(0),chpid[,chpid,...]) [, (CSS(1),chpid[,chpid,...])] ... [, (CSS(n),chpid[,chpid,...])] )	0,1,... for the CSS ID; 2 hexadecimal characters for each static CHPID '*' for each managed CHPID or for control units not connected to a processor
<b>For SMP processors:</b> PATH=(chpid[,chpid]...)	
<b>For XMP processors:</b> LINK=((CSS(0),link_addr[,link_addr,...]) [, (CSS(1),link_addr[,link_addr,...])] ... [, (CSS(n),link_addr[,link_addr,...])] )	0,1,... for the CSS ID; two or four hexadecimal characters for the link address of each CHPID '*' if not specified
<b>For SMP processors:</b> LINK=(link_addr[,link_addr]...)	
UNITADD=((address[,number]),...)	2 hexadecimal characters for each unit address followed by a decimal number
CUADD=address	1 or 2 hexadecimal characters
SHARED=value	Y or N
PROTOCOL=value	D, S, or S4

**Example:** In the following example control unit OCC0 of type 3995-151 is connected to channel path 20 using link address E4. The control unit is connected to port E4 of switch AA.

```
CNTLUNIT CUNUMBR=OCC0,PATH=(20),UNITADD=((00,256)),LINK=(E4), *  
UNIT=3995-151,SWPORT=((AA,E4)), *  
SERIAL=0123456789,DESC='Building 12'
```

**Note:** Put the serial numbers in quotes, if you use characters such as blanks or commas as part of your serial numbers.

### Device for CSS Definition

A device is specified with the IODEVICE statement. It contains the following keywords:

**ADDRESS**

Specifies the device number and how many devices are to be defined (mandatory).

**UNIT** Specifies the device type (mandatory).

**MODEL**

Specifies the model number of the device, if available (optional).

**PART, PARTITION or NOTPART**

PART and PARTITION specify the candidate list identifying the logical partitions which can access the device (optional).

NOTPART specifies the logical partitions which cannot access the device (optional).

If for an XMP processor the device has access to more than one CSS, the CSS subkeyword is required to indicate to which channel subsystem the partition belongs.

**SERIAL**

Specifies the serial number of the device (optional).

**VOLSER**

Specifies the volume serial number (optional).

**CUNUMBR**

Specifies the number(s) of the control unit(s) the device is attached to (mandatory).

**DESC** Specifies a description of the device (optional).

**UNITADD**

Specifies the unit address that is transmitted on the channel path to select the I/O device (optional). If not specified, the last two digits of the device number are used.

**PATH** Specifies the preferred channel path (optional).

**TIMEOUT**

Specifies whether the I/O interface timeout function is to be active (optional).

**STADET**

Specifies whether the Status Verification Facility is to be enabled or disabled (optional).

**SCHSET**

Specifies the subchannel set ID where the device is located.

**PPRCUSE**

Specifies the PPRC usage for DASD devices (optional).

**Syntax:****Syntax:**

---

ADDRESS=(device\_number,number\_of\_units)

4 hexadecimal characters  
followed by a decimal number  
in the range 1 to 4095

---

UNIT=device\_type

---

up to 8 alphanumeric characters

---

MODEL=model\_number

up to 8 alphanumeric characters



LOCANY=value	Y or N
NUMSECT=number	decimal number
OFFLINE=value	Y or N
OWNER=value	VTAM or OTHER
PCU=number	decimal value in the range 1 to 4095
SETADDR=value	0, 1, 2, or 3
TCU=value	2701, 2702, or 2703

**Example for an SMP processor:** In the following example device numbers 0A90 to 0A9F of type 3490 are defined with unit addresses 00 to 0F. Each device is attached to control unit 0A00.

```
IODEVICE ADDRESS=(0A90,16),UNIT=3490,UNITADD=00,          *
          CUNUMBR=0A00,DESC='VIRTUAL TAPE',SERIAL=033401
```

**Note:** Put the serial numbers in quotes if you use characters such as blanks or commas as a part of your serial numbers.

**Example for an XMP processor:** In the following example, the devices numbers 7400 to 741F of type 3390A are defined together with an explicit candidate list: they can be accessed by partition TRX1 from channel subsystem 0 and from partition TRX2 from channel subsystem 1. The Status Verification Facility is enabled. The devices are placed in subchannel set 0 for channel subsystem 0 (this is the default and needs not be specified) and in subchannel set 1 for channel subsystem 1.

```
IODEVICE ADDRESS=(7400,032),UNITADD=50,CUNUMBR=(7300),    *
          STADET=Y,PARTITION=((CSS(0),TRX1),(CSS(1),TRX2)), *
          SCHSET=((CSS(1),1)),UNIT=3390A
```

## Device for VM Definitions

To define a device to a VM operating system, use the RDEVICE statement. It contains the following keywords:

### DEVNO

Specifies the device number and how many devices are to be defined (mandatory).

### DEVTYPE

Specifies the VM device type (mandatory).

### MODEL

Specifies the VM device model (optional).

## VM Parameters and Features

Additional parameters are device type specific. To find out which parameters and features are available to you for a particular device type, refer to your *Supported Hardware Report* and *I/O Definition Reference*. See “Print Configuration Reports (CBDSREP)” on page 145 for details on how to run the report function. Examples of a *Supported Hardware Report* and of an *I/O Definition Reference* are shown in “Supported Hardware Report” on page 199 and in “I/O Definition Reference” on page 221, respectively.

The syntax of the parameters follow the conventions for the HCPRIO RDEVICE statement as documented in *z/VM: CP Planning and Administration*.

**Syntax:**

DEVNO=(device_number,number_of_units)	4 hexadecimal characters followed by a decimal number in the range 1 to 4095
DEVTYPE=device_type	up to 8 alphanumeric characters
MODEL=device_model	up to 8 alphanumeric characters
parm=value	see the <i>Supported Hardware Report</i> and <i>I/O Definition Reference</i>
FEATURE=(feature1[,feature2]...)	list of device specific features

**Example:**

In the following example, device number 0505 of type 3800-1 is defined. It has the following characteristics:

- Is to be used to print spool files
- Prints any class spool files
- Has the 4-writable-character generation module (WCGM) feature
- Has a delayed purge queue length of 5

```
RDEVICE DEVNO=0505,DEVTYPE=3800,MODEL=1,CLASS=*,
        FEATURE=4WCGMS,DMPSIZE=5
```

**VM Consoles**

A VM console is specified with the RIOGEN statement. It contains the following parameters:

**CONS** Specifies the real device number of the CP primary system console (mandatory).

**ALTCONS** Specifies the device number or a list of device numbers of alternate consoles (optional).

**Syntax:**

CONS=device_number	up to 4 hexadecimal device number
ALTCONS=(device_number[,device_number]...)	list of up to 31 device numbers

**Example:**

The following example defines a primary system console (001F) with alternate console (0050).

```
RIOGEN CONS=001F,ALTCONS=0050
```

A SYSTEM\_CONS can be specified on the IODF statement in the SYSTEM CONFIG file. See “Specify a Production IODF for IPL” on page 50 for more information.

---

## Updating Parts of a Configuration by Migrating Input Files

The HCD incremental update function allows you to modify objects in your IODF by specifying the objects with I/O control statements in files, for example, IOCP or HCPRIO input files, and migrating these input files into your existing IODF.

## Possible Actions on Objects Using the Incremental Update

Table 6 shows what actions you can perform on objects by using the HCD incremental update function. The meaning of the markup is as follows:

- x Action possible, you can make the change.
- Action not possible, you cannot make the change with the batch migration utility but must use the HCD dialog.
- (x) Action possible. These attributes are deleted when the object itself is deleted.
- (—) Action not possible. These attributes cannot be deleted because the object itself cannot be deleted.

See the notes below the table for further instructions on how to add, delete, or change certain objects, their attributes and connections.

Table 6. Actions on IODF Objects

Object/Attributes	Add	Delete	Change
<b>Processor</b>			
ID	x	—	—
Type/model	x	(—)	—
Support level	x	(—)	—
Configuration mode	x	(—)	—
Serial number	x	—	x
Description	x	—	x
SNA address	x	—	x
<b>Channel Subsystem</b>			
ID	x	—	—
Maximum number devices	x	—	x
Description	x	x	x
<b>Partition</b>			
Name	x	x 1)	x 11)
Image number	x	(x)	x11)
Usage type	x 10)	(x)	x
Description	x	x	x
<b>PCIe function</b>			
FID	x	—	—
VF	x	—	—
UNIT/TYPE	x	(x)	x
PCHID/VCHID	x	x	x
PNETID	x	x	x
Partition	x	x	x
Description	x	x	x
<b>Channel path</b>			
CHPID	x	—	—
PCHID/VCHID/AID & PORT	x	x	x 5)
Type	x	(—)	x 5)
Operation mode	x	(—)	x 5)
Access list	x	x	x 5)
Candidate list	x	x	x 5)
Dynamic switch	x	x	x 5)
Switch connection	x	x	x 5; 15)
CF connection	x	x	x 5)
Description	x	x	x 5)
OS parameter	x	x	x 5)
I/O cluster	x	x	x 5)

Table 6. Actions on IODF Objects (continued)

Object/Attributes	Add	Delete	Change
PNETID	x	x	x 5)
<b>Control unit</b>			
Number	x	x 2)	x 4)
Unit/model	x	(x)	x
Description	x	x	x
Serial number	x	x	x
Switch connection	x	x	x 15)
Channel paths	x	(x)	x
DLA	x	x	x
Logical address (CUADD)	x	x	x
Unit addresses	x	(x)	x
Protocol	x	x	x
IOCL	x	x	x
<b>Device</b>			
Number	x	x 3)	x 4)
Unit/model	x	(x)	x
Description	x	x	x
Serial number	x	x	x
Volume serial number	x	x	x
Control units	x	(x)	x
Processor connect	x	(x)	x
Unit address	x	(x)	x
Preferred CHPID	x	x	x
TIMEOUT	x	x	x
STADET	x	x	x
Candidate list	x	x	x
OS connect	x	—	x
Subchannel set	x	(x)	x
Parameters	x	x	x
Features	x	x	x
User parameters	x	x	x
PPRC usage	x	(x)	x
<b>Operating system</b>			
ID	x	—	—
Type	x	(—)	—
Description	x	—	x
D/R site OS	x	—	x
<b>Console</b>			
Device list	x	x 9)	x 13)
Order	(x)	(x)	x
<b>Switch</b>			
ID	x	—	—
Unit/model	x	(—)	x
Ports (installed range)	x	(—)	x 8)
Serial number	x	—	x
Description	x	—	x
Switch connection	x	x 14)	x 15)
Address	x	—	x
<b>Ports</b>			
ID	x	—	—
Name	x	(—)	x
Occupied indicator	x 15)	x 15)	n.a.
<b>Switch configuration</b>			
ID	x	—	—

Table 6. Actions on IODF Objects (continued)

Object/Attributes	Add	Delete	Change
Description	x	—	x
Default connection	x	—	x
<b>Port configuration</b>			
Allowed connection	x	—	x
Prohibited connection	x	—	x
Dedicated connection	x	—	x
Blocked indicator	x	x	n.a.

References to IOCP in the following notes refer to files with extended syntax as described in “Changing I/O Configurations by Editing Files” on page 87.

**Note:**

1. To delete a partition, specify all connected channel paths (defined via access or candidate lists) together with their attached I/O units without referring to the partition and without repeating the partition in the RESOURCE statement.

**Note:** Because of a preprocessing step, which removes all CHPIDs to be modified in the IODF and cleaning up LPARs not referenced anymore, the use of the NOTPART keyword can lead to unwanted changes. It is recommended to use NOTPART only together with an explicit RESOURCE statement specifying the logical partitions.

2. A control unit is implicitly deleted, if its channel paths are re-specified in the IOCP input file together with their attached I/O units (except the control unit) and it no longer has any connection to a processor.
3. A device is implicitly deleted, if its attaching control units are implicitly deleted using the incremental update specification, and there is no additional connection left to any control unit or operating system.
4. To change control unit and device attributes, specify the entire logical control unit(s) (LCU) the control unit or device is part of.
5. To change channel path attributes, specify all logical control units the channel path is connected to in the IOCP input file. Otherwise, the channel path is disconnected from the corresponding control units.
6. An installed port can be set to 'uninstalled' only if it does not belong to the minimum installed port range and does not hold a connection to a channel path or control unit.
7. To delete a console list, specify all contained devices using the RDEVICE statement but do not include the devices in a RIOGEN statement.
8. If the usage type is not specified and you add a partition, the usage type is automatically defined: if the IOCP input file contains a CF receiver channel path with the partition in its access or candidate list, the usage type is set to CF/OS, if not, the usage type is set to OS.
9. To change the partition name or partition number specify the whole partition configuration including all channel paths with attached I/O units which have the partition in their access and candidate lists.
10. (No longer used.)
11. To change a complete console device list, use the RIOGEN statement.  
To remove a single device from the console list, specify the corresponding RDEVICE statement and omit the RIOGEN statement.

12. To delete a switch-to-switch connection, specify a switch via a SWITCH statement and omit the switch-to-switch connection in the SWPORT parameter.
13. When updating switch ports new connections always overwrite a previous connection or status. To be updated with an occupied status the port must currently not be connected.

## How to Invoke the Incremental Update

1. Specify your objects with IOCP or OS control statements. Note that you can add additional parameters and SWITCH statements to exploit the extended migration as describes under “Changing I/O Configurations by Editing Files” on page 87).
2. Invoke the *CBDSMIGR* utility with the incremental parameter OP or IP (see “Migrate I/O Configuration Statements (CBDSMIGR)” on page 126).

### Example 1: Adding a Partition

In this example, you specify a partition in your input file that does not yet exist in the IODF. The attached control units and devices are already defined in the IODF for another processor.

The following figure illustrates the result after the incremental update:

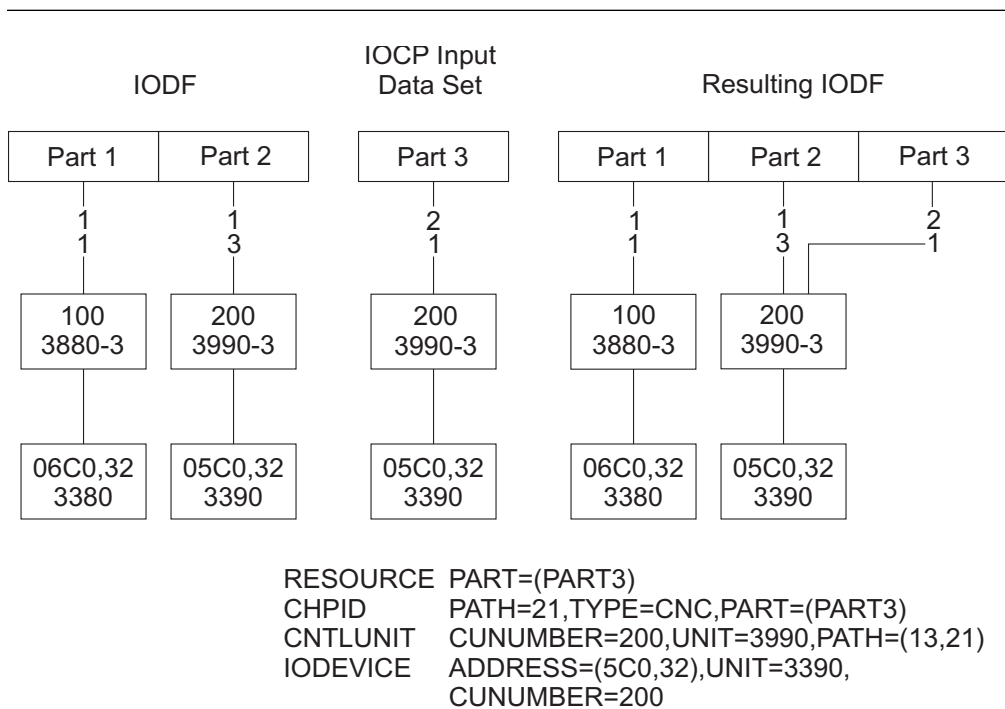

Figure 25. Partial Migration of an IOCP Input File. A new partition is added. Control units and devices are mapped.

The partition is added and the control unit and devices are mapped. For a detailed description when control units and devices are mapped, refer to “Migrating Additional IOCP Input Files” on page 82.

### Example 2: Replacing a Channel Path and Attached Control Unit

In this example, you specify a channel path with attached control unit and devices in an IOCP input file. The channel path, the control unit, and one device already exist in the IODF.



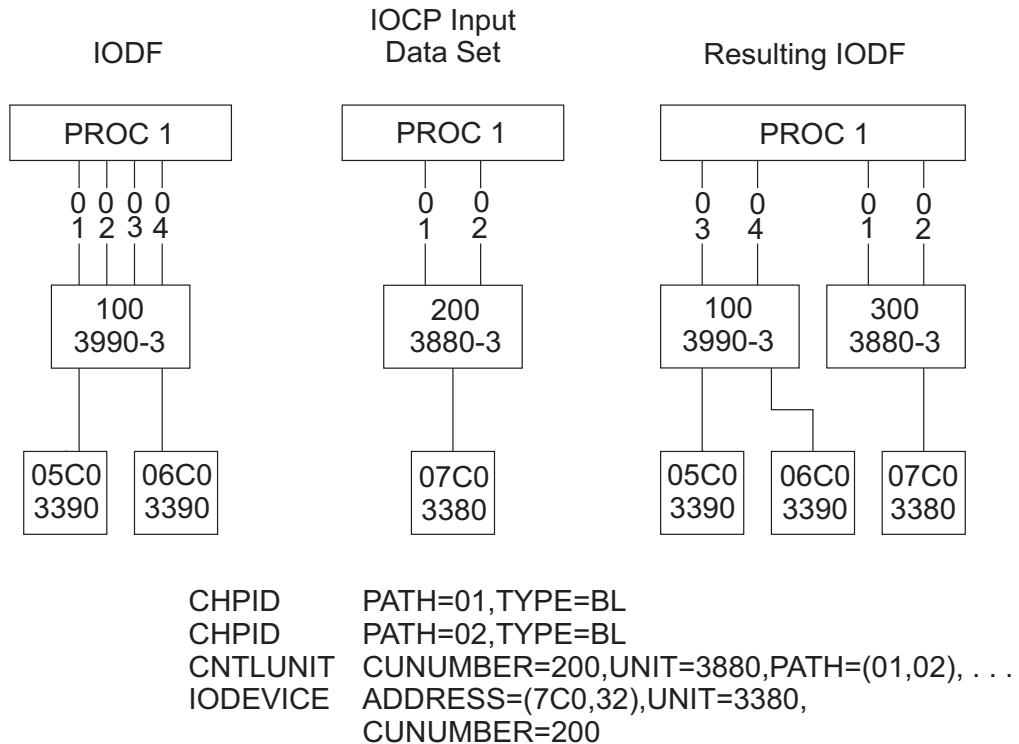

Figure 27. Partial Migration of an IOCP Input File. CHPIDs are defined as in the IOCP input file

The channel paths in the IODF are deleted and newly defined as they are defined in the IOCP input file.

#### Example 4: Replacing a Control Unit that Attaches to Two Processors

In this example, you want to replace existing control units and devices by another type. The control units and devices are attached to two processors.

The incremental update must be done in several steps:

1. Specify another control unit number in your IOCP input file than the one in the existing IODF. Specify the CHPID, CNTLUNIT, and IODEVICE control statements.
2. Migrate your input file for the first processor.



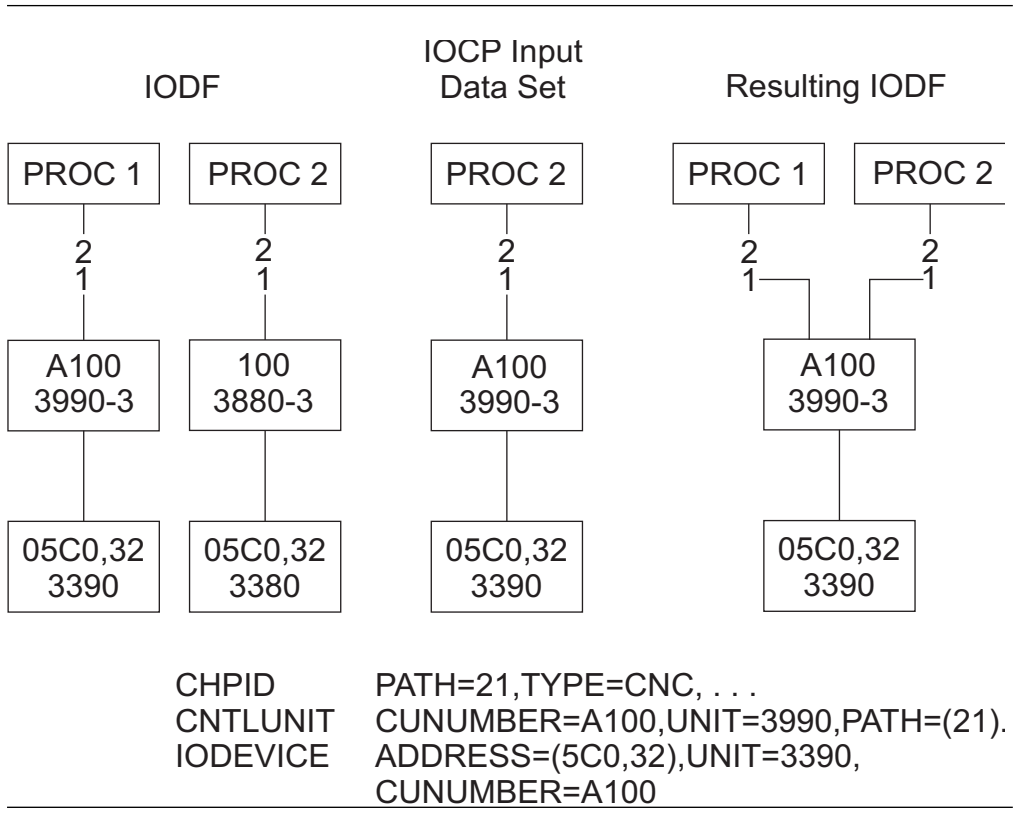

Figure 29. Partial Migration of an IOCP Input File. Control unit defined for two processors is migrated to the second processor.

### Example 5: Updating an Operating System

In this example, you update an operating system by adding and changing devices.

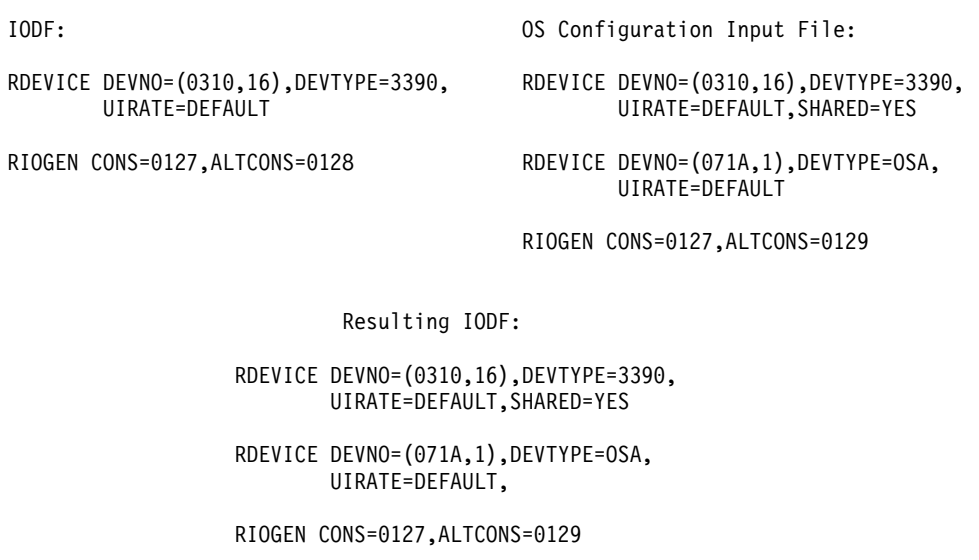

Figure 30. Partial Migration of an OS Configuration Input File

If you migrate an OS configuration input file, specify a processor and partition, with which device definitions in the input files will be associated in the IODF, with the *associations* input string parameter of the *CBDSMIGR* utility (see “Migrate I/O Configuration Statements (CBDSMIGR)” on page 126). HCD uses this information to map devices correctly if the IODF contains duplicate device numbers. For more information about this mapping, refer to “Migrating Additional OS Input Files” on page 85.

---

## Resolving Migration Errors

If HCD detects an error when migrating, it writes a message into the HCD migration log.

You can display the HCD migration log through a browser or editor. The name of the HCD migration log file is as follows:

```
CBDSMIGR MESSAGES filemode
```

## Errors Detected During Assembly Process

During migration, HCD invokes the assembler to parse the input statements. If it encounters an error, it writes a message to the message list. This message points to an assembler listing for more details.

The name of the assembly listing file is `CBDSMIGR LISTING filemode`.

At the bottom of the assembly listing, you find the statement numbers where errors were detected. If you locate the statement numbers in the listing, you see the IOCP statement in error followed by the error message. The following examples show IOCP statements and the assembly messages issued.

### Example 1

In this example an entry in the IOCP input file is commented out, but the continuation character \$ is left in column 72.

```
7493 *          CNTLUNIT CUNUMBR=02E,PATH=(02,06),SHARED=N,UNIT=3990,      91A$
7494 *          UNITADD=((E),32)),PROTOCL=S4
```

The assembler listing shows the following message:

```
IEV144  *** ERROR ***  BEGIN-TO-CONTINUE COLUMNS NOT BLANK
```

### Example 2

This example shows a line with only 87A being included in the IOCP input file.

```
7493 *          CNTLUNIT CUNUMBR=234,PATH=24,SHARED=N,UNIT=3880,          87A
7494 *          UNITADD=(30,16),PROTOCL=S4                                87A
7495                                                                 87A
7496 *IOCP                                                                87A
```

The assembler listing shows the following message:

```
IEV144  *** ERROR ***  OPERATION CODE NOT COMPLETE ON FIRST CARD
```

### Example 3

This example shows a wrong channel path type in the CHPID statement.

```
CHPID PATH=((00)),TYPE=CMC
```

The assembler listing shows the following message:

```
IEV144  *** MNOTE ***  8,003 TYPE=CMC IS INVALID
```

## Errors Detected During Validation Process

During the validation process, HCD checks that the definitions being migrated do not cause any conflicts with existing definitions in the IODF and with other definitions being migrated. HCD also checks that the contents of the input files is valid. The errors are shown in the message list and migration log.

Figure 31 shows error messages in the migration log.

```
HCD                                     Time: 15:28 Date: 01-11-21 Page: 1
z/VM 4.4.0 HCD
(1) FILE=REGTEST FR07DECK G 1

Statement  Orig  Sev  Msgid  Message Text
          9  (1)  E  CBDA230I Duplicate unit address F0 on channel path 01 of processor BOEHCD.
          5  (2)  W  CBDA265I Type of control unit 0131 assumed as 3880-13 to attach device 01F0.
          I  CBDA516I No output written to IODF. VALIDATE processing forced due to errors.

Total Messages  Terminating  Error  Warning  Informational
                3              0       1        1           1

Return Code was 8
```

Figure 31. Example: HCD Migration Log

The messages are sorted according to their severity, and within a certain severity level according to their occurrence.

The value in the **Orig** column points to the input data set that caused this error. At the top of the migration log you find a reference list that shows the values with the names of the input files (see the line marked **1**).

In Figure 31 the first message line means, that the statement number 9 in the input file 1 (file IOCP01 DECK A) is the cause of the error message.

The following examples show common validation errors and explain their causes.

### Example 1

```
Statement Orig Sev  Msgid  Message Text
          7  (1)  E  CBDA154I Channel path type CNC is not supported by channel
          path ID 3A.
```

This message is issued, because an ESCON channel is defined although the support level was defined in the IODF as having only parallel channels installed for the specified CHPID. To resolve this, either change the channel type in the IOCP input file, or change the processor type or support level in the IODF.

### Example 2

```
Statement Orig Sev  Msgid  Message Text
          4  (1)  E  CBDA234I Unknown type 38823 of control unit 0000
          specified.
```

This message is issued, because HCD does not know the control unit type 38823. Check *the Supported Hardware Report* for information on valid control unit and device types.

### Example 3

Statement	Orig	Sev	Msgid	Message Text
228	(1)	W	CBDA265I	Type 3800-3 assumed for control unit DD32 to attach the device 0828.
227	(1)	I	CBDA534I	Control unit DD32 is assumed as 3800-1.

These messages are issued, because HCD has to choose the control unit type among several models.

The control unit model 3800-1 is indicated as default model in the UIM (information message CBDA534I is issued). As processing goes on, it is necessary to change the default model (3800-1) to another model (3800-3) to attach a device type which is not supported by the default control unit model (warning message CBDA265I is issued).

**Note:** The sequence of messages is shown in reverse order in the migration log file since the messages are sorted according to decreasing severities. To resolve this, either include the model in the IOCP input file, map the control unit types via HCD profile entries, or update the IODF using HCM, if HCD has made an incorrect assumption.



---

## Chapter 12. How to Invoke the HCD Functions

### PI

This chapter handles the following topics:

- It describes how to invoke the available HCD functions in “Methods to Invoke HCD Functions.”
- For your quick reference, it provides a “List of Available HCD Functions” on page 121.
- In section “Programming Information for HCD Functions” on page 122 all required information is provided about the function's APIs and how they are invoked using the shipped REXX utilities.

---

### Methods to Invoke HCD Functions

You can select from the following alternatives to invoke the HCD functions:

1. You can use the *CBDMGHCP* command together with an input parameter string that specifies the desired function and other required parameters. The format of this command is as follows:

HCD Function Invocation
<pre>▶—OSRUN—CBDMGHCP—PARM—=—'    Input Parameter String  '—▶</pre>

However, before you can launch this command, you have to specify the required FILEDEF statements. For formats of the input parameter strings and the used FILEDEF DD names see the sections where each HCD function is described in more detail.

**Note:** For the HCD function *Generate CP I/O configuration file from active system configuration* (see “Generate I/O Configuration File from Control Blocks (CBDSRDEV)” on page 170), *CBDMGHCP* is not invoked.

2. Another possibility for invoking the HCD functions is to use an ATTACH or LINK module programming statement to invoke the module *CBDMGHCP*.

When you invoke the module, register 1 must contain the address of a two-word parameter list.

#### Word 1

Address of input parameter (see “Input Parameter String” on page 120), preceded by a two byte length field.

#### Word 2

Address of a list of alternate DD names. If not used, the address must be binary zero. For the list format of alternate DD names see “List of Alternate DD Names” on page 173.

You may overwrite standard DD names listed in Table 8 on page 172 as desired before invoking HCD.

**Note:** Trailing commas in the parameter string can be omitted.

- For the available HCD functions, a REXX utility is shipped with z/VM HCD which you can use on your z/VM system to invoke the desired HCD functions (see “List of Available HCD Functions” on page 121). The provided REXX utilities can be customized to fit your needs, but this is not recommended. The invocation interface for these utilities is included in the sections where the single HCD functions are described.

The advantage of the utilities is that they compose the *OSRUN* statement with the appropriate input parameter string for the desired function. Also, the utilities establish the appropriate FILEDEF statements and clear them after completion.

## Input Parameter String

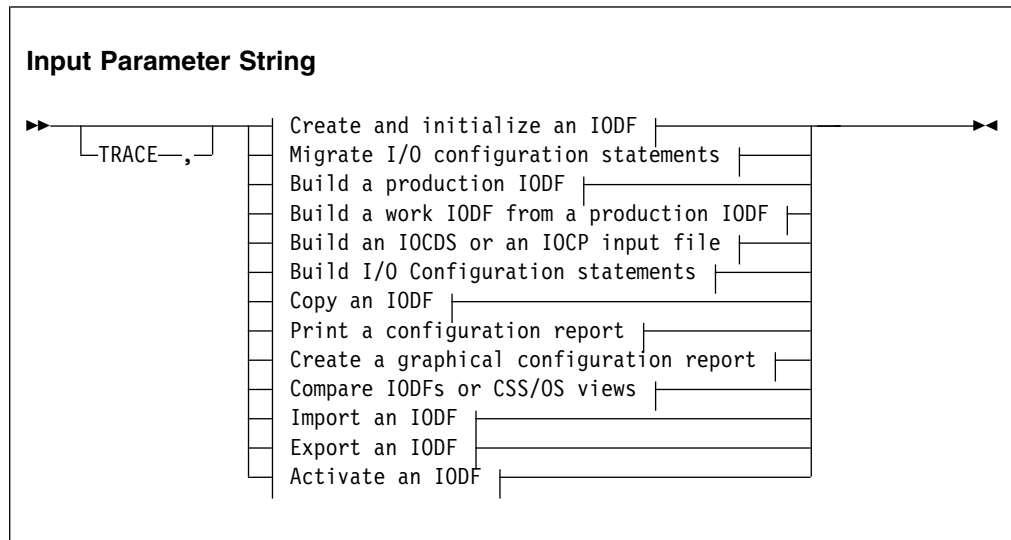

### TRACE

When specified, the HCD trace will be activated.

### Input Parameter String

You will find a detailed description of the input parameter strings for each HCD function in the following sections.

You can also activate tracing by adding the TRACE command in the HCD profile. This allows you to specify the trace parameters in more detail. In this case, you must allocate DD name HCDPROF to the HCD profile. For more information, see “Defining an HCD Profile” on page 26, and “TRACE Command” on page 249.

## What is Common to all REXX Utilities

All REXX utilities are named *CBDSxxxx*. The following general description applies to all REXX utilities, except *CBDSRDEV*.

- You can invoke a REXX utility just by its name (and optionally, a '?'). Then you get help information on the required and optional input parameters and on default values if available. With this information, you can re-invoke the utility.
- You can invoke a REXX utility completely by its name and input parameters. All parameters are positional, so for parameters which are optional, you must either specify an asterisk (\*) at the corresponding position to accept the default or specify a value to overwrite the default. You can also omit optional parameters if no further required parameter follows and you want to accept the defaults for

all other following optional parameters. This mechanism is explained in more detail in the invocation examples provided with REXX utility **CBDSIODF** in “Utility CBDSIODF” on page 123.

- When starting, all REXX utilities read a user configuration file called **CBDCONF NAMES**. In this file, for all REXX utilities, you can set individual options or parameters. You cannot overwrite these options or parameters with the invocation, but you can edit the **CBDCONF NAMES** file before invocation. Also for each such option or parameter, a description of its meaning is provided. Furthermore, in **CBDCONF NAMES**, you can find and edit the defaults for the optional input parameters.

For example, you can specify the default name of the message log file for each utility. Or for utilities that have a **REPLACE** option, like for example **CBDESCOPY**, you can specify whether you want to have a confirmation message issued before actually replacing the target file.

- Each utility launches the appropriate **FILEDEF** statements required for the invoked HCD function. Especially the following **FILEDEF** statements for **HCDPROF**, **HCDMLOG**, **HCDTRACE** and **HCDLOAD** are contained in each utility and the following file IDs are used:
  - **HCD PROFILE \*** for the HCD profile (**HCDPROF**)
  - **CBDSxxxx MSGLOG A** for the HCD message log (**HCDMLOG**)
  - **CBDSxxxx TRACE A** for the HCD trace file (**HCDTRACE**).
  - **CBDMOD LOADLIB \*** for the HCD load module (**HCDLOAD**).
- After successful invocation, each utility constructs the **OSRUN** command (introduced in Chapter 12, “How to Invoke the HCD Functions,” on page 119) which invokes the desired HCD function. The input parameter string required for this command is composed by the utility from the information you passed with the parameters or from the accepted defaults.
- For file naming during the invocation of the REXX utilities, you must observe the rules described in “IODF and Activity Log Naming Conventions” on page 31.

---

## List of Available HCD Functions

Table 7 shows a list of available HCD functions. Each list item points to the page where you find the section that describes the function with all required API information and the REXX utilities with which you can invoke these functions.

*Table 7. List of Available HCD Functions*

HCD Function	Reference	REXX Utility
Create and initialize a work IODF	“Create and Initialize an IODF (CBDSIODF)” on page 123	CBDSIODF
Migrate an I/O configuration file to a work IODF	“Migrate I/O Configuration Statements (CBDSMIGR)” on page 126	CBDSMIGR
Build a production IODF from a work IODF	“Build a Production IODF (CBDSPROD)” on page 133	CBDSPROD
Build a work IODF from a production IODF	“Build a Work IODF from a Production IODF (CBDSWORK)” on page 135	CBDSWORK

Table 7. List of Available HCD Functions (continued)

HCD Function	Reference	REXX Utility
Build an IOCP file from a production IODF or validated work IODF, or perform an IOCDS download	“Build an IOCDS or an IOCP Input File (CBDSIOCP)” on page 137	CBDSIOCP
Build I/O configuration statements from a production or work IODF	“Build I/O Configuration Data (CBDSCONF)” on page 140	CBDSCONF
Copy an IODF	“Copy IODF (CBDSCOPY)” on page 143	CBDSCOPY
Print a report from an IODF	“Print Configuration Reports (CBDSREP)” on page 145	CBDSREP
Produce a graphical representation of the I/O configuration defined in a specified IODF	“Create a Graphical Configuration Report (CBDSDRAW)” on page 148	CBDSDRAW
Compare IODFs	“IODFs or CSS/OS Compare Reports (CBDSCOMP)” on page 151	CBDSCOMP
Import an IODF at another user ID	“Import an IODF (CBDSIMP)” on page 158	CBDSIMP
Export an IODF to another node ID/user ID	“Export an IODF (CBDSEXP)” on page 160	CBDSEXP
Activate a hardware and/or software configuration	“Activate a Configuration (CBDSACT)” on page 163	CBDSACT
Manage configuration packages	“Manage Configuration Packages (CBSDPKG)” on page 168	CBSDPKG
Generate CP I/O configuration file from control blocks	“Generate I/O Configuration File from Control Blocks (CBDSRDEV)” on page 170	CBDSRDEV

---

## Programming Information for HCD Functions

This section contains a subsection for each available HCD function with all information required for invoking it from within your own program or for invoking the REXX utility that in turn invokes the desired HCD function.



### CBDSIODF Invocation Format:



where

#### **iodfid**

is the file ID of the new work IODF. This parameter actually consists of three positional parts: filename filetype filemode. The file name is required, the default file type is WORKIODF, the default file mode is A. For file naming, you must observe the rules described in "IODF and Activity Log Naming Conventions" on page 31.

**Note:** IODFs are always allocated with filemode suffix 6, for example A6. Any other suffix is ignored.

#### **size**

is the number of 4 K blocks of the new work IODF (default is 1024 blocks, the minimum value is 16, the maximum value is 524287).

#### **REPlace**

replaces an existing file with the same file ID as the new IODF

Specify an \* for, or omit optional parameters. Then they are defaulted.

A description of up to 128 characters for the IODF can be passed in a file (fixed block, logical record length 80) with default file ID IODFnn CNTL \*. This description becomes part of the generated IODF and appears in any textual configuration report or compare report for this IODF. Or you can find this description in the graphical interface of HCM (**IODFs** dialog ---> **Details**).

As a default, the utility requests an activity log file for the new IODF.

#### **Example 1:**

Invoking the REXX utility as:

```
cbdsiodf iodf11 * * 256  
or:  
cbdsiodf iodf11 workiodf a 256
```

creates the new IODF: IODF11 WORKIODF A with a size of 256 4K blocks

#### **Example 2:**

Assuming file IODF12 CNTL A contains the text: *IODF is used for future updates.*, then the invocation of:

```
cbdsiodf iodf12  
or:  
cbdsiodf iodf12 * * *  
or:  
cbdsiodf iodf12 workiodf a 1024
```

creates new IODF IODF12 WORKIODF A with the default size of 1024 4K blocks and the description 'IODF is used for future updates.'

**Note:** In **Example 1**, the two asterisks are required for the optional, but positional parameters `filetype` and `filemode`, because the default value for the optional parameter `size` is overwritten. In **Example 2** you can omit all optional parameters, because you accept all default values

## Migrate I/O Configuration Statements (CBDSMIGR)

This HCD function migrates a file containing I/O configuration statements into an existing work IODF. Input files for this function can be:

- An existing IOCP file or an existing HCPRIO input file
- A file containing I/O configurations for:
  - Operating systems
  - Processors
  - Switches

that you have built using REXX utility **CBDSCONF**, see “Build I/O Configuration Data (CBDSCONF)” on page 140.

- A file containing RDEV control block information that you have build using REXX utility **CBDSRDEV**, see “Generate I/O Configuration File from Control Blocks (CBDSRDEV)” on page 170.

This function is invoked by passing the following input parameter string to HCD:

## Migrate I/O configuration statements

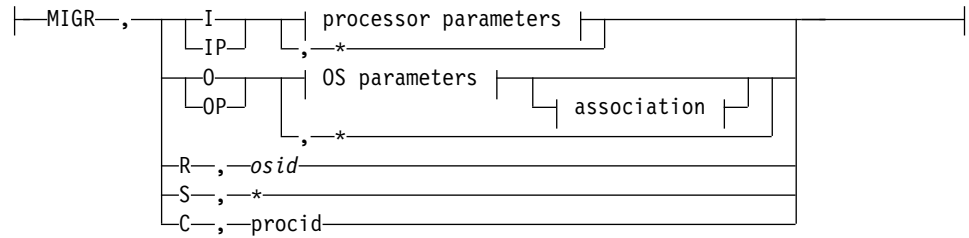

### processor parameters:

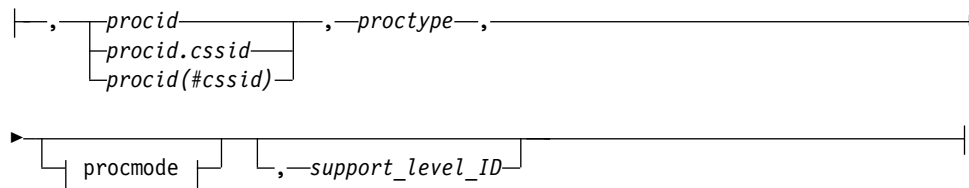

### OS parameters:

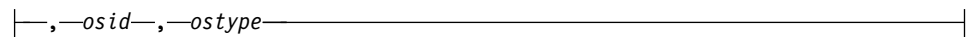

### association:

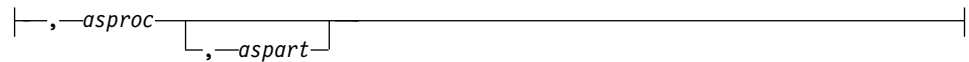

### procmode:

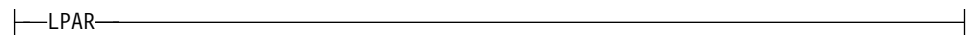

## I | IP | O | OP | R | S | C

Function indicator:

- I** Migration of processor configuration statements (for example, IOCP data sets)
- IP** Partial migration of processor configuration statements
- O** Migration of OS configuration statements (for example, HCPRIO data sets)
- OP** Partial migration of OS configuration statements
- R** RDEV migration, where *osid* specifies the operating system ID (up to eight characters)
- S** Switch migration
- C** Physical channel ID (PCHID) migration

### Processor Parameters:

**procid** Processor ID (up to 8 characters)

**procid.cssid, procid(#cssid)**

When migrating an SMP processor to an XMP processor, the channel subsystem ID of the target processor may be appended to the processor ID as one character either by a # and in parenthesis or by a dot (.). The default is 0.

**proctype**

Processor type and model separated by a hyphen, for example 9672-E08

**procmode**

Processor mode

**LPAR** If the processor operates in LPAR mode (default, and a required choice).

**support\_level\_ID**

Support level ID associated with the processor. This parameter is required if the processor does not already exist and several support level IDs are installed for a supported processor type. The support level ID can be obtained by the *Supported Hardware Report* described in "Print Configuration Reports (CBDSREP)" on page 145. For an example of such a report refer to "Supported Hardware Report" on page 199.

If you do not specify a support level, the highest support level will be used for the processor.

**Note:** The support level ID is unique to HCD and does not correspond to the EC level of the processor.

- \* Migrates one or more processor configurations, retrieving the processor name, model, and support level from the ID statement in the input deck. The ID statement must therefore explicitly include the NAME, UNIT, and MODEL keywords, as described in "Processor" on page 93. (Note that the LEVEL and MODE keywords are not explicitly required, and will be defaulted by HCD to the highest level and mode if not specified on the ID statement.)

On the other hand, if the processor ID, model, and support level *are* provided on this invocation of CBDSMIGR, then the NAME, UNIT, and MODEL keywords on the input deck are ignored. (See "Note (1)" in "Processor" on page 93.)

### OS Parameters:

**osid** Operating system ID (up to 8 characters)

**ostype** OS type (MVS or VM)

**asproc** Associated processor. For more information, see "Migrating Additional OS Input Files" on page 85

**aspart** Associated partition. For more information, see "Migrating Additional OS Input Files" on page 85

- \* Migrates multiple OS configurations. Scans the input data set to determine which OS configurations are to be processed. For successful migration the configurations must include the IOCONFIG statement described in "Operating System" on page 90.

Switch related wildcard:

- \* Migrates switch configurations of multiple switches. Scans the input data set to determine which switch configurations are to be processed. For successful migration the configurations must include the SWCONF statement described in "Switch Configuration" on page 92.

FILEDEF statements are required for the following files when invoking HCD:

DD name	Description	req/opt
HCDLOAD	HCD load module	required
HCDIODFT	IODF into which I/O definitions are to be migrated	required
HCDIN	I/O configuration input file	required
HCDLIB	MACLIB containing the parsing macros (CBDZPARS)	required
HCDMLOG	HCD Message Log file	required
HCDPRINT	File for migration log	optional
HCDASMP	File for assembly listing	optional
HCDPROF	HCD profile (when using extended migrate function)	optional
HCDTRACE	Trace file	optional

For defaults of HCDPRINT and HCDASMP, for pre-allocating additional migration files, and for viewing the migration log see "Resolving Migration Errors" on page 115.

## Utility CBDSMIGR

The REXX utility **CBDSMIGR** migrates input files of various types (listed earlier in this section) into an existing work IODF.

### CBDSMIGR Invocation Format:

```

▶▶—CBDSMIGR—workid—confid—ind—id—  

                                     |type| |mode| |slevel|
▶▶

```

where

#### workid

is the file ID of an existing work IODF. This parameter actually consists of three positional parts: filename filetype filemode. The file name is required, the default file type is WORKIODF, the default file mode is A.

#### confid

is the file ID of the input configuration file (consisting of filename filetype filemode)

#### ind

characterizes the I/O configuration file to be migrated. It may take the following values:

**I, IP** I = IOCP file migration and IP = Partial IOCP file migration.

**O, OP** O = OS configuration file migration and OP = Partial OS configuration file migration.

- S Switch file migration.
- R RDEV migration.
- C PCHID migration.

**id**

**for ind=I,IP**

name of processor (up to eight characters or wildcard \*)

For XMP processors, you can also specify a channel subsystem like *procid.cssid* (whereas *procid#cssid* is not allowed).

**for ind=O,OP**

name of OS configuration (up to eight characters or wildcard \*)

**for ind=S**

switch ID (two hexadecimal characters or wildcard \*)

**for ind=R**

name of OS configuration

**for ind=C**

name of processor

**type**

**for ind=I,IP**

type(-model) of processor

**for ind=O,OP**

type of OS configuration (default: VM)

**for other ind**

omit

**mode**

This parameter is valid for ind=I,IP only – in which case it must be specified as LPAR.

**slevel**

This parameter is valid for ind=I,IP only and specifies the processor support level. For valid support levels refer to column **SUPLEVID** in the *Supported Hardware Report*. If you omit this parameter, the most current support level is assumed.

Specify an \* for, or omit optional parameters. Then they are defaulted.

**Note:** If you specify a wildcard (\*) for parameter **id**, you must not specify any values for parameters **type**, **mode** and **slevel**. Furthermore, an ID statement is required in the input deck, and on that ID statement you must specify the NAME, UNIT, and MODEL keywords. (The LEVEL and MODE keywords are not explicitly required, and will be defaulted by HCD to the highest level and mode if not specified on the ID statement.)

**Example 1:**

To migrate the IOCP file called IOCP DECK A to a work IODF called IODF99 WORKIODF A, invoke the REXX utility as:

```
cbdsmigr iodf99 * a iocp deck a i boevm3 2097-E12
```

or:

```
cbdsmigr iodf99 workiodf a iocp deck a i boevm3 2097-E12 lpar h080130
```

The `i` in this invocation designates that the input file is an IOCP file. The name of the processor is `BOEVM3` and it is a processor of type-model `2097-E12`. The `lpar` value for the `mode` parameter indicates that the processor is running in LPAR mode (a required choice). Its support level is `h080130`.

#### Example 2:

To migrate the OS configuration file called `CONFIG DECK01 A` to a work IODF called `IODF88 WORKIODF A`, invoke the REXX utility as:

```
cbdsmigr iodf88 * a config deck01 a o zvm01
or:
cbdsmigr iodf88 workiodf a config deck01 a o zvm01 vm
```

The OS configuration is identified with its name `zvm01` and it is of type `VM`.

#### Example 3:

To migrate the input file called `CBDMCONF RDEVLIST A` which previously has been generated from `RDEV` control blocks of the VM system (using `CBDSRDEV`) to a work IODF called `IODF77 WORKIODF A`, invoke the REXX utility as:

```
cbdsmigr iodf77 * a cbdmconf rdevlist a r realvm
or:
cbdsmigr iodf77 workiodf a cbdmconf rdevlist a r realvm
```

The OS configuration is identified with its name `REALVM`.

#### Example 4:

You have two 2064 processors and you wish to migrate them both to a 2084 processor that will eventually have two logical channel subsystems (LCSSs) defined. The first processor and its LPARs will be migrated to `CSS0`. The second processor and its LPARs will be migrated to `CSS1`. The two 2064 processors are both defined in `IODF41` as `TRX1` and `TRX2`.

1. Create two decks:

```
CBDSCONF IODF41 WORKIODF A TRX1 DECK A I TRX1
CBDSCONF IODF41 WORKIODF A TRX2 DECK A I TRX2
```

2. Create a new work IODF:

```
CBDSIODF IODF50 WORKIODF A (2000)
```

3. Migrate the two decks to one processor 2084 TRX in `IODF50 WORKIODF A`:

```
CBDSMIGR IODF50 WORKIODF A TRX1 DECK A I TRX.0 2084-A08
CBDSMIGR IODF50 WORKIODF A TRX2 DECK A IP TRX.1 2084-A08
```

Depending on migration errors, it may be necessary to change the input files `TRX1 DECK A` and `TRX2 DECK A` and iterate step 3. For example, the 2064 processors may have channel paths of type `OSA` or `BL` defined which are not supported by the 2084 processor. In such a case, the migrate step would only be successfully performed if you had removed or changed the corresponding `CHPID` statements.

The result is one 2084 processor `TRX` with `CSS0` (containing `TRX1`) and `CSS1` (containing `TRX2`). At this point, you continue with `HCM` to update the configuration according to your needs.

#### Example 5:

To add a SCSI device to your IODF file, first create a partial OS configuration file called SCSI ASM A. Define the FCP devices and the FBASCSI devices with their associated WWPNs and LUNs. (In this example, it is assumed that you have defined FCP devices 8100 and 8101 to your processor configuration.) Invoke the REXX Utility CBDSMIGR on the IODF file IODF07 WORKIODF A with a partial update to the existing OS configuration CT1:

```
CBDSMIGR IODF07 WORKIODF A SCSI ASM A OP CT1
```

where SCSI ASM A might contain:

```
IOCONFIG ID=00,NAME=CT1,TYPE=VM
RDEVICE DEVNO=(8100,2),DEVTYPE=FCP
RDEVICE DEVNO=(0000,2),DEVTYPE=FBASCSI
USERPRM=((ATTR,2105),(FCPDEV,(8100,8101)),(WWPN,(5005076*
300C204DA,5005076300CE04DA)),(LUN,(515D000000000000,515E*
000000000000)))
```

For more information on SCSI devices and operands, see the SET EDEVICE and QUERY EDEVICE commands in the *z/VM: CP Commands and Utilities Reference*, as well as the EDEVICE configuration statement and the Defining and Managing SCSI FCP Disks chapter in *z/VM: CP Planning and Administration*.

## Build a Production IODF (CBDSPROD)

This HCD function creates a production IODF from a work IODF.

After the production IODF has been built, it is copied back to the work IODF. Thus, the work IODF can be used for further updates. Since the production IODF may be larger than the original work IODF, the work IODF may be automatically enlarged to accommodate the contents of the production IODF.

If the work IODF has an associated MCF, the MCF data set is copied and associated to the production IODF.

This function is invoked by passing the following input parameter string to HCD:

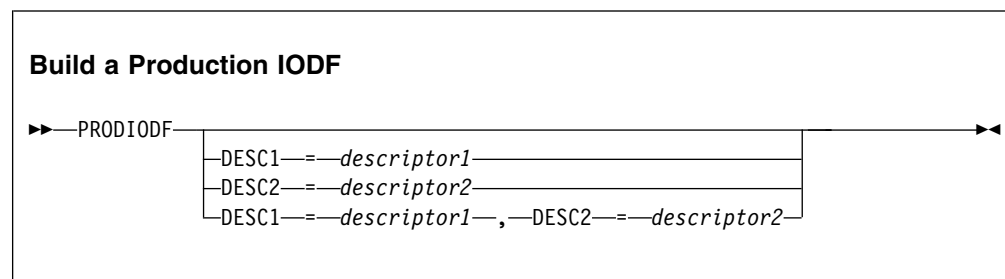

**DESC1**=*descriptor 1*

May have maximum eight characters. The default is the minidisk label of the production IODF minidisk.

**DESC2**=*descriptor 2*

May have maximum eight characters. The default is the file name of the production IODF.

The descriptor fields describe the IODF and will be part of the HSA token.

**Attention:** If you specify asterisks (\*\*), equals (==), pluses (++), or minuses (--) for the IODF suffix in LOADxx, you should never change the default descriptor field values, because these values are used to find the current IODF during IPL. Take this relationship into consideration, as well, if you copy the IODF to a different data set name.

FILEDEF statements are required for the following files when invoking HCD:

DD name	Description	req/opt
HCDLOAD	HCD load module	required
HCDIODFS	Work IODF	required
HCDIODFT	Production IODF	required
HCDMLOG	HCD Message Log file	required
HCDTRACE	Trace file	optional
HCDPROF	HCD profile	optional

### Utility CBDSPROD

The REXX utility **CBDSPROD** generates a production IODF from a work IODF.

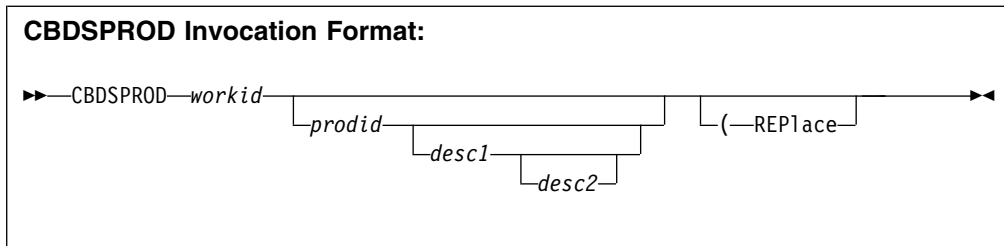

where

**workid**

is the file ID of the source work IODF. This parameter actually consists of three positional parts: filename filetype filemode. The file name is required, the default file type is WORKIODF, the default file mode is A.

**prodid**

is the file ID of the target production IODF. This parameter actually consists of three positional parts: filename filetype filemode. The file name is required. the default file name is the file name of the work IODF. The default file type is PRODIODF, the default file mode is A.

**desc1**

descriptor 1: May have maximum eight characters. The default is the minidisk label of the production IODF minidisk.

**desc2**

descriptor 2: May have maximum eight characters. The default is the file name of the production IODF.

**REPlace**

replaces an existing production IODF with the same file ID as the specified production IODF

Specify an \* for, or omit optional parameters. Then they are defaulted.

**Example 1:**

Invoking the REXX utility as:

```
cbdsprod iodf12 workiodf b iodf11 prodiodf a
```

creates the new production IODF: IODF11 PRODIODF A from the specified work IODF IODF12 WORKIODF B. The *desc1* parameter defaults to the minidisk label of the production IODF minidisk, for example KAT191. The *desc2* parameter defaults to IODF11 in our example.

**Example 2:**

Invoking the REXX utility as:

```
cbdsprod iodf12 workiodf b iodf11 prodiodf a sysres myiodf
```

creates the same production IODF as in **Example 1**, however the *desc1* parameter results in SYSRES and the *desc2* parameter results in MYIODF.



consists of three positional parts: filename filetype filemode. The default for the file name is the file name of the production IODF, the default file type is WORKIODF, the default file mode is A.

**REPlace**

replaces an existing file with the same ID as the work IODF.

Specify an \* for, or omit optional parameters. Then they are defaulted.

**Example:**

The following invocation creates work IODF IODF12 WORKIODF A from the production IODF IODF11 PRODIODF. If you want to enlarge the work IODF by creating it before, specify the REPLACE option.

```
cbdswork iodf11 * a iodf12 * * (rep
```

or:

```
cbdswork iodf11 prodiodf a iodf12 workiodf a (rep
```

## Build an IOCDs or an IOCP Input File (CBDSIOCP)

This HCD function builds the IOCDs or the IOCP input file using the definitions of a production IODF. In order to use this HCD function, you must have privilege class C,F and G.

This function is invoked by passing the following input parameter string to HCD:

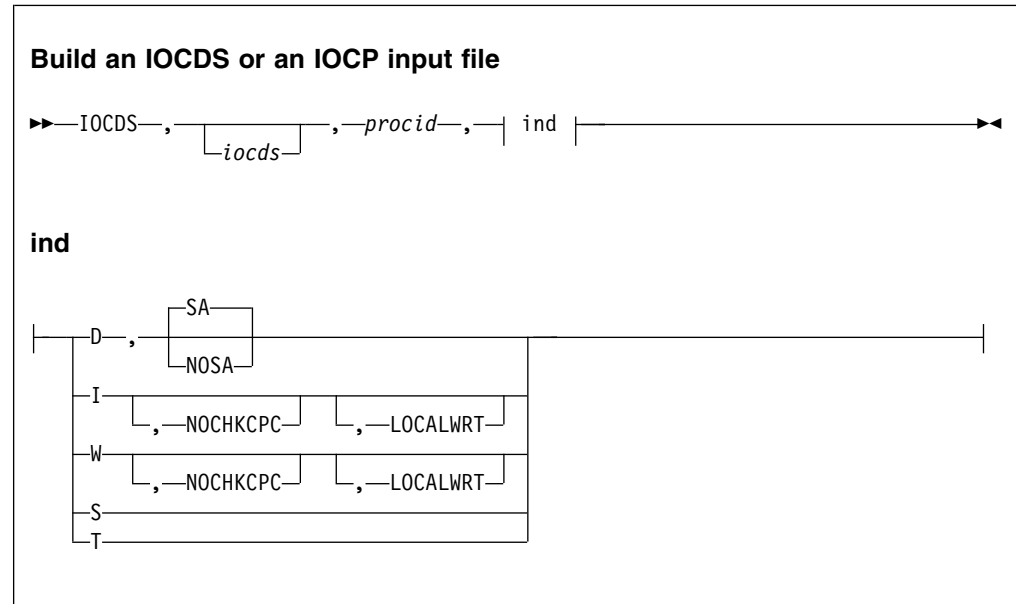

### **iocds**

is a two-character IOCDs identifier, if building an IOCDs

### **procid**

Processor ID

### **D | I | W | S | T**

One-character request code:

**D** Build an IOCP input file

**SA** The generated IOCP statements can be used for the stand-alone IOCP program (default).

#### **NOSA**

Depending on the HCD profile option MIGRATE\_EXTENDED=YES, the generated IOCP statements have additional information that can be used for the extended migration. This information is shown as comments to IOCP.

**Note:** An IOCP input file generated with operand NOSA may not be accepted by the stand-alone IOCP program, because of differences between the IOCP program running in z/VM and the stand-alone IOCP program.

**I** Build an IOCDs

**W** Build an IOCDs with dual-write option

#### **NOCHKCPC**

Write an IOCDs regardless of the type of the receiving processor. Refer to "Supported Hardware Report" on page 199 for a list of processor

types that can receive an IOCDS in preparation for a processor upgrade and for processor types for which such an IOCDS can be written.

#### LOCALWRT

This parameter enforces a local IOCDS write. A defined SNA address which is normally used by HCD to initiate a remote IOCDS build to the support element with the designed SNA address, is ignored in this case.

- S Build an IOCDS and set the IOCDS active for next POR
- T Build an IOCDS with dual-write option and set the IOCDS active for next POR

FILEDEF statements are required for the following files when invoking HCD:

DD name	Description	req/opt
HCDLOAD	HCD load module	required
HCDIODFS	IODF from which the processor configuration is read.	required
HCDDECK	CMS file, if the function <i>Build IOCP Input File</i> is requested. Then IOCP statements are stored into this CMS file.	required
HCDMLOG	HCD Message Log file	required
HCDCNTL	CMS file used when invoking the IOCDS download. This file contains one record, namely the MSG1 text. The file must be fixed block, logical record length 80.	required
SYSPRINT	SYSPRINT file for IOCP output listing (requested for build IOCDS)	optional
HCDPROF	HCD profile	optional
HCDTRACE	Trace file	optional

#### Utility CBDSIOCP

The REXX utility **CBDSIOCP** performs an IOCDS download or builds an IOCP input file from a processor configuration defined in a production IODF.

##### CBDSIOCP Invocation Format:

```

▶▶—CBDSIOCP—prodid—procid—ind—outfile—(—options)—▶▶

```

where

##### **prodid**

is the file ID of the production IODF which is the source for building the IOCDS or IOCP input file. This parameter actually consists of three positional parts: filename filetype filemode. The file name is required, the default file type is PRODIODF, the default file mode is \*.

##### **procid**

is the name of processor configuration

**ind**

is the function indicator:

**I** for invoking IOCP to download an IOCDS to the support element

**W** same as with **I** but with dual write on the support element

**D** for building an IOCP input file, without invocation of IOCP. This is the default.

**outfile**

is for:

**I | W** two-character identifier of the IOCDS to be written; this identifier must be specified for **I** or **W**.

**D** file ID if the IOCP input file. The default is procid IOCP A.

**options****REPLACE**

replaces an existing IOCP input file (for ind: D)

**NOCHKPC**

writes an IOCDS regardless of the type of the receiving processor (for ind: I or W)

Specify an \* for, or omit optional parameters. Then they are defaulted.

**Example 1:**

Assume, you have a production IODF called IODF11 PRODIODF A from which you want to create an IOCDS and download it on processor CT1 into IOCDS slot A3. You achieve this with the following invocation:

```
cbdsiopc iodf11 * * ct1 i a3
```

or:

```
cbdsiopc iodf11 prodiodf a ct1 i a3
```

**Note:** File CT1 CNTL passes the MSG1 operand of the IOCP ID statement with up to eight characters text without any keyword and quotation-marks.

**Example 2:**

Assume, you have a production IODF called IODF22 PRODIODF A from which you want to create an IOCP input file for processor CT1. You achieve this with the following invocation:

```
cbdsiopc iodf22 * * ct1
```

or:

```
cbdsiopc iodf22 prodiodf a ct1 d ct1 iopc a
```

Both invocations generate the desired IOCP input file as: CT1 IOCP A.

## Build I/O Configuration Data (CBDSCONF)

This HCD function builds I/O configuration data from an IODF that describe

- Operating system configurations
- Processor configurations
- Switch configurations
- FCP device data

and to store them in a file. The file created can be edited and re-migrated into the IODF.

You invoke this function by passing the following parameter string:

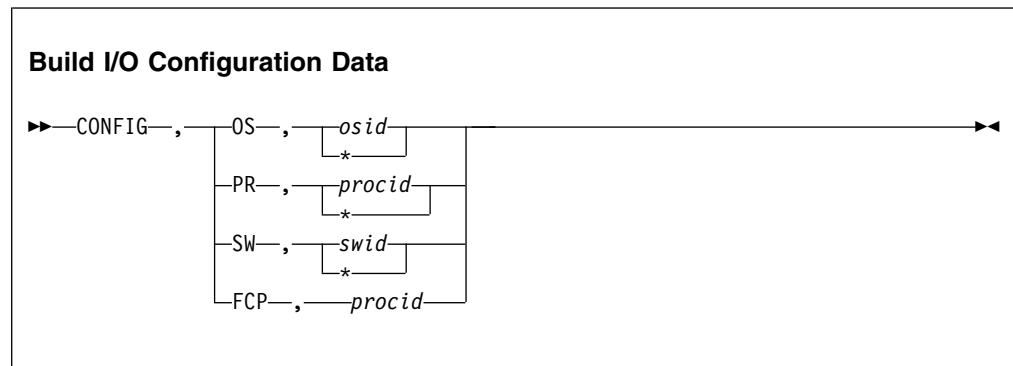

### OS | PR | SW | FCP

Function indicator:

**OS** Build OS configuration statements

**osid** OS configuration ID (up to 8 characters)

- \* If you specify \* in place of an OS configuration ID, HCD searches for a list of OS configuration IDs in a file allocated to HCDCNTL. If no file has been allocated to DD name HCDCNTL, statements are built for all operating systems in the IODF.

**PR** Build processor configuration statement

**procid** processor ID (up to 8 characters)

- \* If you specify \* in place of a processor ID, HCD searches for a list of processor IDs in a file allocated to HCDCNTL. If no data set has been allocated to DD name HCDCNTL, statements are built for all processors in the IODF.

**SW** Build switch configuration statements

**swid** Switch ID (2 hexadecimal characters)

- \* If you specify \* in place of a switch ID, HCD searches for a list of switch IDs in a file allocated to HCDCNTL. If no file has been allocated to DD name HCDCNTL, statements are built for all switches in the IODF.

Furthermore, specifying \* as switch ID, and setting the profile keyword SHOW\_CONFIG\_ALL to YES, additionally generates configuration statements for control units and devices without a processor and OS connection.

**FCP** Export FCP device data into CSV output format

**procid** Processor ID (up to 8 characters) for which to export the FCP device data.

HCD exports the FCP device configurations for a specific processor from the currently accessed IODF as comma-separated values into a CSV output format, which you can use as input to the WWPNN Prediction Tool to assign world-wide port names to virtualized FCP ports. This HCD output file is also referred to as an *FCP SAN configuration template file*.

Specify the desired processor ID in the **confid** field (as shown in "Utility CBDSCONF"). The data set will be automatically allocated (record length 132, record format fixed block).

If the data set already exists, you will be asked to confirm replacing it with the new one.

FILEDEF statements are required for the following files when invoking HCD:

DD name	Description	req/opt
HCDLOAD	HCD load module	required
HCDIODFS	Source IODF from which I/O definitions are extracted.	required
HCDDECK	Generated output file containing the I/O configuration statements.	required
HCDMLOG	HCD Message Log file	required
HDCNTL	Optional for specifying a list of operating systems, processors, or switches.	optional
HCDPROF	HCD profile	optional
HCDTRACE	Trace file	optional

### Utility CBDSCONF

The REXX utility **CBDSCONF** generates an output file from a production or work IODF containing I/O configuration data.

#### **CBDSCONF Invocation Format:**

```

▶▶—CBDSCONF—iodf—outfile—conftype—confid—(—REPLACE—)▶▶

```

where

#### **iodf**

is the file ID of a work or production IODF which contains the configuration data to be extracted into an output file. This parameter actually consists of three positional parts: filename filetype filemode.

#### **outfile**

is the file ID of the configuration file to be built. This parameter actually consists of three positional parts: filename filetype filemode.

For **conftype** = **I**, **O**, or **S**:

- filename = \* will default to CONFIG
- filetype = \* will default to DECK
- filemode = \* will default to A

For **conftype** = **F**:

- filename = \* will default to FCPCONF
- filetype = \* will default to CSV
- filemode = \* will default to A

### **conftype**

specifies the type of configuration to be generated:

- I** processor configuration
- O** operating system configuration
- S** switch configuration
- F** FCP device configuration

### **confid**

ID of configuration for which I/O definition statements are built:

- For **conftype** = **I**, it is the processor ID
- For **conftype** = **O**, it is the OS configuration ID
- For **conftype** = **S**, it is the switch ID
- For **conftype** = **F**, it is the processor ID

For **conftype** = **I**, **O**, or **S**, specifying an '\*' generates the I/O definition statements for all configurations of the given type. This is the default.

For **conftype** = **F**, an '\*' is not valid.

### **REPlace**

replaces an existing output file with the same file ID as the one specified with *outfile*.

### **Example 1:**

The following example shows how to invoke **CBDSCONF** to build a configuration file CONFIG DECK A containing processor configuration PROC1 from IODF IODF33 WORKIODF A.

```
cbdsconf iodf33 workiodf a * * * i proc1  
or:  
cbdsconf iodf33 workiodf a config deck a i proc1
```

### **Example 2:**

The following example shows how to invoke **CBDSCONF** to build a configuration file CONFIG DECK A containing all OS configurations from IODF IODF44 WORKIODF A.

```
cbdsconf iodf44 workiodf a * * * o  
or:  
cbdsconf iodf44 workiodf a config deck a o
```

## Copy IODF (CBDSCOPY)

This HCD function copies the content of the IODF addressed by DD name HCDIODFS into another IODF addressed by DD name HCDIODFT. If the IODF has an associated activity log, that log is also copied. Likewise, if an HCM master configuration file (MCF) is associated to the IODF, it is also copied along with the IODF. However, a change log file (CHLOG), if available, is not copied.

Note that this function will always creates the target IODF in the newest version.

This function is invoked by passing the following parameter string.

```
▶▶—COPYIODF—————▶▶
```

You can use this utility to copy a work IODF which has reached its limits into a previously initialized larger target IODF. In this case, you must create this larger work IODF before, using the HCD function *Create and Initialize an IODF* (see “Create and Initialize an IODF (CBDSIODF)” on page 123).

If you did not create the target IODF before copying, the utility creates it with the same size as the source IODF.

Note that copying a V4 IODF upgrades the copied IODF to the V5 format. Since the V5 IODF requires less space than a V4 IODF, you should perform the copy to a target IODF allocated with the number of used blocks of the source IODF.

FILEDEF statements are required for the following files when invoking HCD:

DD name	Description	req/opt
HCDLOAD	HCD load module	required
HCDIODFS	Source IODF	required
HCDIODFT	Target IODF	required
HCDMLOG	HCD Message Log file	required
HCDPROF	HCD profile	optional
HCDTRACE	Trace file	optional

### Utility CBDSCOPY

The REXX utility **CBDSCOPY** copies an IODF. The activity log, if it exists, is also copied.

```
CBDSCOPY Invocation Format:  
▶▶—CBDSCOPY—fromiodf—toiodf———▶▶  
└──(—REPlace—)──┘
```

where

**fromiodf**

is the file ID of the source IODF to be copied. This parameter actually consists of three positional parts: filename filetype filemode.

**toiodf**

is the file ID of the target IODF (filename filetype filemode). If the specified file does not yet exist, it is created. If it exists, and you did not specify the REPlace option, the copy request is rejected.

**REPlace**

replaces an existing target IODF.

**Example:**

The following example shows how to copy a work IODF into another work IODF with the same file name on a different disk.

```
cbds copy iodf44 workiodf a iodf44 workiodf c (replace
```

## Print Configuration Reports (CBDSREP)

This HCD function prints reports about:

- The hardware definitions stored in the specified IODF.
- The processors, control units, and devices supported in your installation.

This function is invoked by passing the following parameter string.

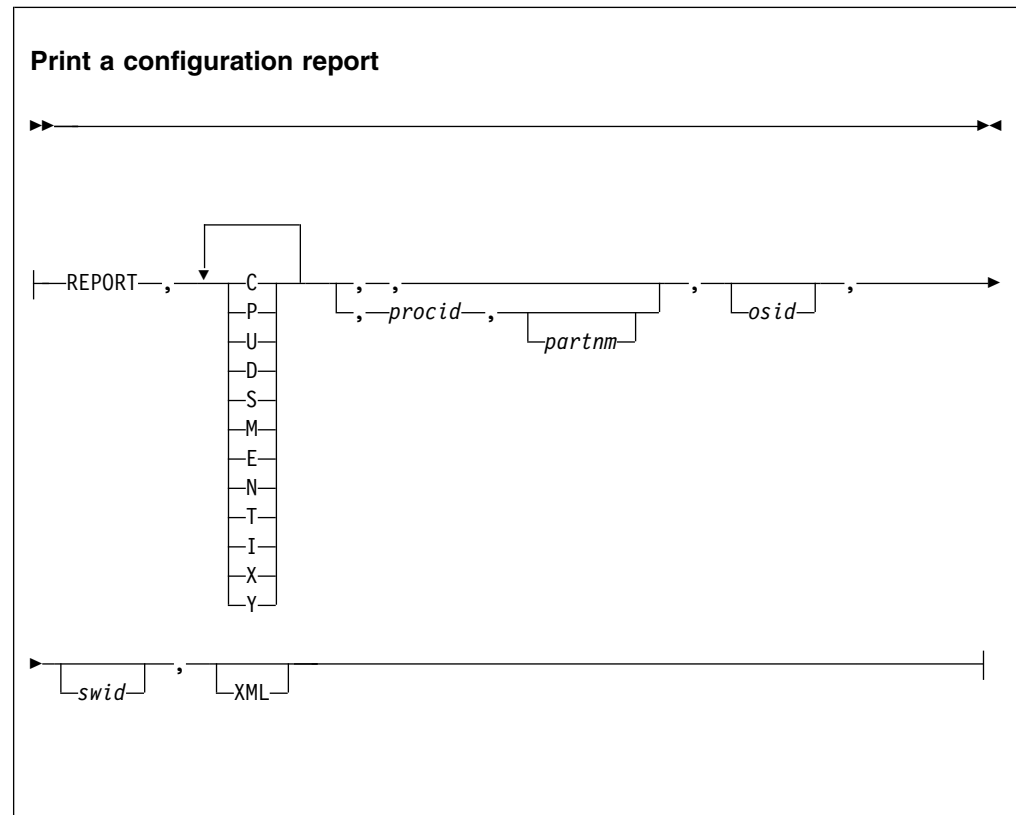

**C | P | U | D | S | M | N | T | X | Y**

Type of the report. Specify one or more of the following codes in any order, with no separating characters:

- C** CSS report - CSS Summary Report only
- P** CSS report - Channel Path Detail Report
- U** CSS report - Control Unit Detail Report
- D** CSS report - Device Detail Report
- S** Switch report
- M** OS report - OS devices
- N** OS report - VM consoles
- T** CTC Report
- X** Supported Hardware Report
- Y** I/O Definition Reference

### **procid**

Processor ID to limit a CSS report or a CTC connection report to a specific processor.

**partnm**

Partition name to limit a CSS report or a CTC connection report to a specific logical partition. The processor ID must also be specified; otherwise, the partition name is ignored for the CSS and CTC connection report.

**osid**

Operating system configuration ID to limit an OS report to a specific operating system configuration.

**swid**

Switch identifier to limit a Switch report to a specific switch

**XML**

Specifies that you wish to print your report in XML output format.

**Note:** It is recommended to print the I/O path report separately from the other reports. If you do wish to print an I/O path report together with any other reports, however, then your limitations for the I/O path report are propagated to all other specified reports. These limitations to a certain processor, partition or operating system can be either user-specified or else HCD will take the active processor, partition or operating system as the default.

FILEDEF statements are required for the following files when invoking HCD:

DD name	Description	req/opt
HCDLOAD	HCD load module	required
HCDIODEFS	Source IODF from which the report is desired	required
HCDRPT	Output file: record size 133, record format fixed block	required
HCDMLOG	HCD Message Log file	required
HCDPROF	HCD profile	optional
HCDTRACE	Trace file	optional

**Utility CBDSREP**

The REXX utility **CBDSREP** generates a textual report of a work IODF.

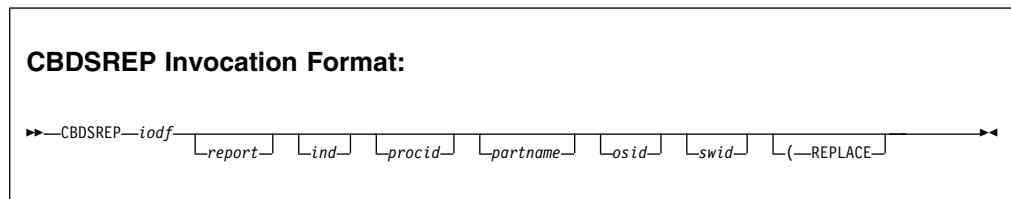

where

**iodf**

file ID (filename filetype filemode) of the IODF from which the report is desired (default file type: WORKIODF)

**report**

file ID (filename filetype filemode) of output file for the report (default: iodf REPORT A)

**ind**

report type that you want to generate. Specify one or more of the following codes in any order in one string (like: CPUD, which is the default):

- C** CSS report - CSS Summary Report only
- P** CSS report - Channel Path Detail Report
- U** CSS report - Control Unit Detail Report
- D** CSS report - Device Detail Report
- S** Switch report
- M** OS report - OS devices
- N** OS report - VM consoles
- T** CTC report
- X** Supported Hardware Report
- Y** I/O Definition Reference

**procid**

in case of a CSS report, this parameter specifies the processor configuration ID to which the CSS report will be restricted; otherwise this parameter is ignored.

**partname**

in case of a CSS report, this parameter specifies a certain logical partition to which the CSS report is to be restricted; otherwise this parameter is ignored.

**osid**

specifies the OS configuration ID, to which the OS Report (**M**) will be restricted. If this parameter is not specified, the OS Report is given for all defined OS configurations.

**swid**

in case of a Switch Report (**S**), this parameter specifies the switch ID to which the report is to be restricted; otherwise this parameter is ignored.

**REPLACE**

option to replace a file with the same ID as the report output file)

Specify an \* for, or omit optional parameters. Then they are defaulted.

**Example 1:**

The following example shows how to generate the four types of CSS reports from the work IODF IODF11 WORKIODF A.

```
cbdsrep iodf11 workiodf a iodf11 report a cpud
or:
cbdsrep iodf11
```

**Example 2:**

The following example generates the same report as **Example 1**, however limited to processor PROC1.

```
cbdsrep iodf11 * * * * * proc1
```

**Example 3:**

The following example shows how to generate a Supported Hardware Report from IODF11.

```
cbdsrep iodf11 * * * * * x
or:
cbdsrep iodf11 workiodf a iodf11 report a x
```

## Create a Graphical Configuration Report (CBDSDRAW)

This HCD function produces a graphical representation of the I/O configuration based on the definitions in the IODF.

This function is invoked by passing the following parameter string.

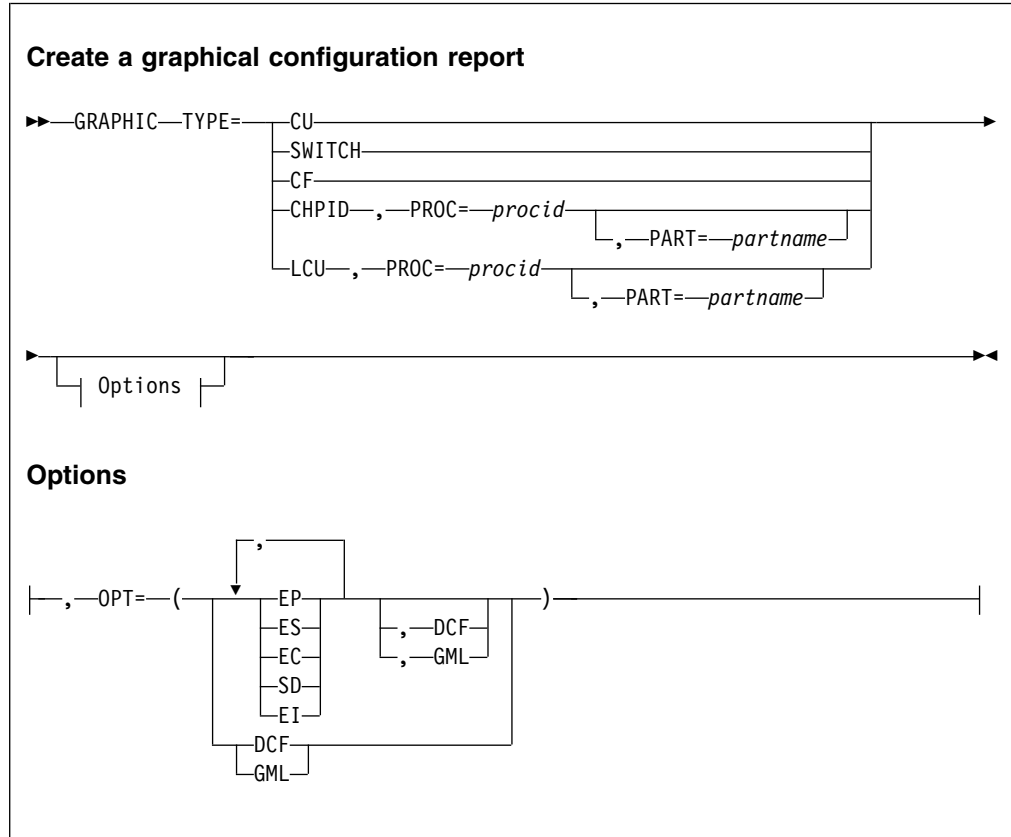

**TYPE** Type of the report. Specify one of the following codes:

**CU** CU report

**SWITCH**  
Switch report

**CF** CF connection report

**CHPID**  
CHPID report

**LCU** LCU report

**PROC** Processor ID for which the LCU or CHPID report is produced.

**PART** Partition name to limit an LCU or CHPID report to one partition.

**OPT** Options of the report. Specify one or more of the following codes in any order, separated by a comma:

**EP** Exclude partition

**ES** Exclude switch

**EC** Exclude CTC control units

**SD** Show control unit description (instead of serial number)

- EI** Exclude index
- DCF** DCF output format
- GML** GML output format

**Note:** If no output format is specified, the specification in the HCD profile is used. If the HCD profile does not specify a formatting type either, the default BookMaster format is used.

FILEDEF statements are required for the following files when invoking HCD:

DD name	Description	req/opt
HCDLOAD	HCD load module	required
HCDIODFS	Source IODF	required
HCDRPT	Output file: record size 200, record format FB.	required
HCDMLOG	HCD Message log file	required
HCDPROF	HCD profile file	optional
HCDTRACE	Trace file	optional

## Utility CBDSDRAW

The REXX utility **CBDSDRAW** extracts a graphical report from an IODF.

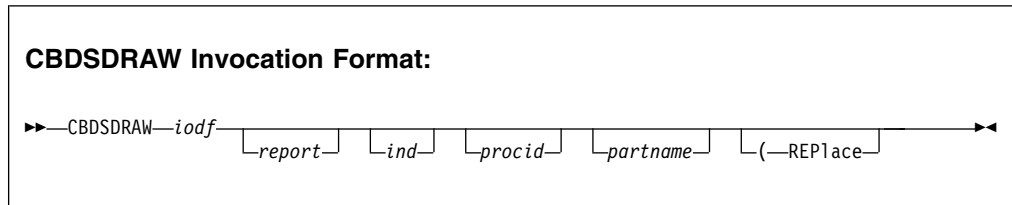

where

### **iodf**

is the file ID of the IODF to be reported (filename filetype filemode). The filename is required, the default file type is WORKIODF. File type and file mode can be specified with \*.

### **report**

file ID of output file for the report (default: iodfname SCRIPT A)

### **ind**

indicates the report type:

**CU** Control Unit Report; this is the default

### **SWITCH**

Switch Report

**CF** Coupling Facility Report

### **CHPID**

Channel Path Report

**LCU** Logical Control Unit Report

### **procid**

specifies the name of the processor configuration. This parameter is required for **CHPID** and **LCU** type reports; otherwise it is ignored.

**partname**

specifies the name of the partition. This parameter is optional and only required if you want to restrict **CHPID** and **LCU** type reports to a specific logical partition; otherwise it is ignored.

**REPlace**

replaces an existing file with the same file ID as the report output file.

Specify an \* for, or omit optional parameters. Then they are defaulted.

**Example 1:**

The following example generates a graphical Logical Control Unit Report from IODF IODF11 WORKIODF A, limited to the processor configuration PROC1.

```
cbdsdraw iodf11 * * * * * lcu proc1
```

or:

```
cbdsdraw iodf11 workiodf a iodf11 script a lcu proc1
```

**Example 2:**

The shortest invocation possible:

```
cbdsdraw iodf11
```

generates as the default a *Control Unit Report* from the specified work IODF IODF11 WORKIODF A into IODF11 SCRIPT A.

## **IODFs or CSS/OS Compare Reports (CBDSCOMP)**

This HCD function compares two IODFs and reports the differences. You can compare the IODFs from the CSS, OS, and switch perspective.

In addition, you can limit the CSS, OS, and switch perspective by single compare reports, and the CSS perspective by LPARs.

You have to allocate the new IODF with DD name HCДИODFS, and the old IODF with DD name HCДИODFT for comparing IODFs. If you compare the CSS to the OS definition, you always compare within one IODF that must be allocated to HCДИODFS.

You invoke this function by passing the following parameter string.

**Note:** The parameter string must not exceed 100 characters.

## Compare IODFS or CSS/OS Reports

COMPARE, Print Options for IODF Compare Report  
 Print Options for CSS/OS Compare Report

### Print Options for IODF Compare Report:

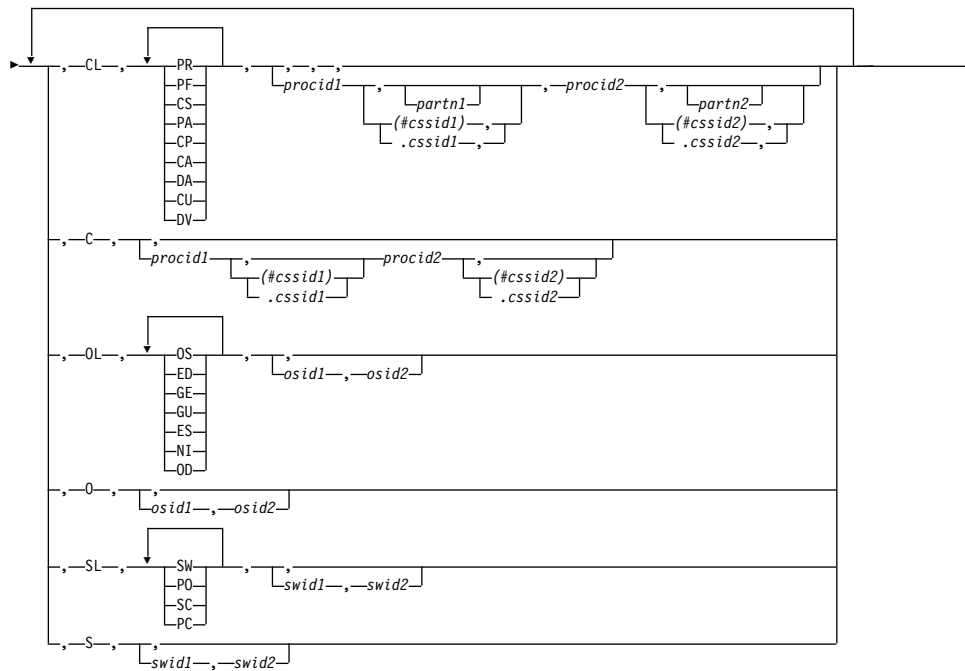
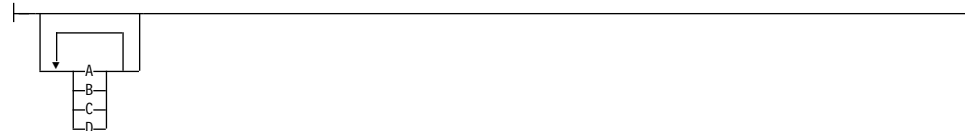

### Print Options for CSS/OS Compare Report:

C, D, procid, partn, osid

### Print Options for IODF Compare Report:

Specify one or more of the following print options, without separating characters, in exactly this order. If you do not select an option, the default print options are used (**A**: Print inserted data, and **B**: Print deleted data). That means, HCD prints a report of

- IDs of added or deleted objects, and those objects, that have added or deleted relations
- IDs of added relations

- Attributes of objects that are different in both IODFs

**A** Print inserted data:

When you select this option, HCD prints a report of all attributes, and relations of added objects.

**B** Print deleted data:

When you select this option, HCD prints a report of all attributes, and relations of deleted objects.

**C** Print unchanged data:

When you select this option, HCD prints a report of all attributes, and relations of unchanged objects.

**D** Print unchanged item IDs

When you select this option, HCD prints a report of the IDs of unchanged objects. But this applies only, if the Print unchanged data option is not selected.

**CL | C | OL | O | SL | S**

Type of the report. Specify one or more of the following codes in any order, with no separating characters:

**CL** Limit the CSS compare report by single compare reports and LPARs

**PR** Processor compare

**PF** PCIe Function compare

**CS** Channel subsystem compare

**PA** Partition compare

**CP** Channel path compare

**CA** Control unit attachment compare

**DA** Device attachment compare

**CU** Control unit compare

**DV** Device compare

**procid1**

New processor ID

**partn1** Partition name of the new processor ID

**cssid1** selected CSS ID of the new XMP processor, either appended by a # and in parenthesis or appended by a dot (.). If the CSS ID is specified for one processor only (old or new), the CSS ID for the other processor is defaulted to CSS ID 0.

**procid2**

Old processor ID

**partn2** Partition name of the old processor

**cssid2** selected CSS ID of the old XMP processor, either appended by a # and in parenthesis or appended by a dot (.)

- C** Indicates CSS compare report
- procid1**  
New processor ID
- cssid1** selected CSS ID of the new XMP processor, either appended by a # and in parenthesis or appended by a dot (.). If the CSS ID is specified for one processor only (old or new), the CSS ID for the other processor is defaulted to CSS ID 0.
- procid2**  
Old processor ID
- cssid2** selected CSS ID of the old XMP processor, either appended by a # and in parenthesis or appended by a dot (.)
- OL** Limit OS compare report by single compare reports
- OS** Operating system compare
- NI** OS console compare
- OD** OS device compare
- osid1** New operating system ID
- osid2** Old operating system ID
- O** Indicates OS compare report
- osid1** New operating system ID
- osid2** Old operating system ID
- SL** Limit switch compare report by single compare reports
- SW** Switch compare
- PO** Switch port compare
- SC** Switch configuration compare
- PC** Port configuration compare
- swid1** New switch ID
- swid2** Old switch ID
- S** Indicates SWITCH compare report
- swid1** New switch ID
- swid2** Old switch ID

**Print Options for CSS/OS Compare Report:**

- C** Print all devices

**No Selection**

If no selection is made, only devices are printed that are

- Defined for the CSS, but not for the OS
- Defined for the OS, but not for the CSS
- Defined for both, but of different device type

- D** Indicates CSS/OS compare

**procid** Processor ID

**partn** Partition name. For more information, see “Compare CSS / Operating System Views” on page 73.

**osid** Operating system ID

FILEDEF statements are required for the following files when invoking HCD:

DD name	Description	req/opt
HCDLOAD	HCD load module	required
HCDIODEFS	New IODF	required
HCDIODFT	Old IODF	required
HCDMLOG	HCD Message Log file	required
HCDRPT	Report file; record size 133, record format fixed block	required
HCDPROF	HCD profile file	optional
HCDTRACE	Trace file	optional

### Utility CBDSCOMP

The REXX utility **CBDSCOMP** compares configurations in IODFs.

#### CBDSCOMP Invocation Format:

►►—CBDSCOMP—*iodf1*—*iodf2*—┌*reprt*┐┌*view*┐┌*id1*┐┌*id2*┐┌*id3*┐┌(—REPlace—┐►

where

**iodf1**

is the file ID of the new IODF (for view = C, S, or OL) or the file ID of the IODF (for view = D). This parameter actually consists of three positional parameters (filename filetype filemode). All parts are required.

**iodf2**

is the file ID of the old IODF (for view = C, S, or OL). The default is the file ID of the new IODF, see parameter *iodf1*.

**reprt**

file ID of the report output (consisting of filename filetype filemode). The default, if specified with '\* \* \*' is: *iodf1*\_filename COMPARE A.

**view**

is the compare view; if specified, you can select only one from the following:

- C Channel Subsystem View
- S Switch View
- OL OS View limited
- D CSS/OS View

If you specify this parameter with '\*', you get the default which is a combination of C/S/OL views with OL = OS view limited to OD).

**id1**

Here you may specify some ID, which is interpreted according to the value specified with parameter **view**:

- if **C** is specified, **id1** is interpreted as a processor ID, optionally qualified by a CSS ID (*procid.cssid*), and the report is limited to this processor.
- if **S** is specified, **id1** is interpreted as a switch ID and the report is limited to this switch.
- if **OL** is specified, **id1** is interpreted as an OS ID and the report is limited to this operating system.
- if **D** is specified, **id1** is interpreted as a processor ID and the report is limited to this processor.

This parameter can be defaulted with '\*' for C, S, or OL, but is required for **view = D**.

**id2**

Here you may specify some ID, which is interpreted according to the value specified with parameter **view**:

- if **C** is specified, **id2** is interpreted as a processor ID, optionally qualified by a CSS ID (*procid.cssid*), and the report is limited to this processor.
- if **S** is specified, **id2** is interpreted as a switch ID and the report is limited to this switch.
- if **OL** is specified, **id2** is interpreted as an OS ID and the report is limited to this operating system.
- if **D** is specified, **id2** is interpreted as a partition ID and the report is limited to this partition.

This parameter can be defaulted with '\*' for C, S, or OL, but is required for **view = D**.

**id3**

Here you may specify some ID, which is interpreted according to the value specified with parameter **view**:

- if **D** is specified, **id3** is interpreted as an OS ID and the report is limited to this operating system.

This parameter can be defaulted with '\*' for C, S, or OL, but is required for **view = D**.

**REPlace**

replaces an existing report output file.

Specify an \* for, or omit optional parameters. Then they are defaulted.

**Example 1:**

The following example compares the operating system named SCOTT from work IODF IODF33 with the operating system with the same name SCOTT from work IODF IODF44.

```
cbdscomp iodf33 workiodf a iodf44 workiodf a * * * ol scott
or:
cbdscomp iodf33 workiodf a iodf44 workiodf a iodf33 compare a ol scott scott
```

**Example 2:**

The following example creates a CSS/OS compare report and compares the CSS with the OS called SCOTT for processor P301, partition A1, defined in IODF IODF55 PRODIODF A.

```
cbdscomp iodf55 prodiodf a * * * * * d p301 a1 scott
```

or:

```
cbdscomp iodf55 prodiodf a * * * iodf55 compare a d p301 a1 scott
```

## Import an IODF (CBDSIMP)

This HCD function imports configuration data (previously exported from another system) into an IODF. To import an IODF on z/VM, use the REXX utility **CBDSIMP**, as shown in Example 1 on page 159.

This function is invoked by passing the following parameter string.

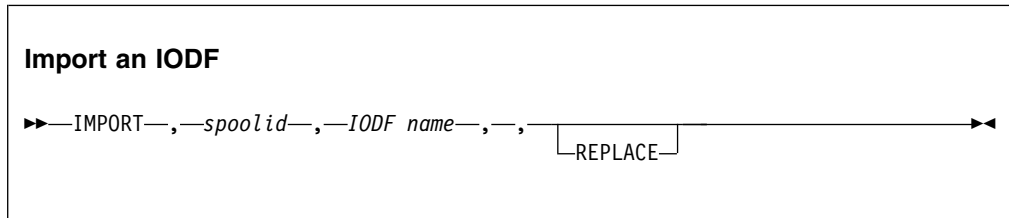

### **spoolid**

is the reader spool ID of the IODF to be imported. You can retrieve the IODF's spool ID with the CMS command Q RDR ALL (for an example output of this command, see "Utility CBDSIMP").

### **IODF name**

Specifies the file ID of the target IODF.

### **REPLACE**

Specifies that an IODF with the same name will be replaced by the received IODF.

FILEDEF statements are required for the following files when invoking HCD:

DD name	Description	req/opt
HCDLOAD	HCD load module	required
HCDMLOG	HCD Message Log file	required
HCDPROF	HCD profile	optional
HCDTRACE	Trace file	optional

## Utility CBDSIMP

The REXX utility **CBDSIMP** imports an IODF by receiving it from the reader spool file.

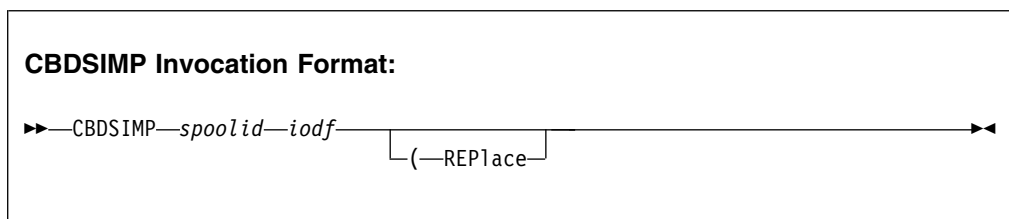

where

### **spoolid**

is the reader spool ID of the IODF to be imported. You can retrieve the IODF's spool ID with the CMS command Q RDR ALL. The output of this command is structured like shown here:

ORIGINID	FILE	CLASS	RECORDS	CPY	HOLD	DATE	TIME	NAME	TYPE	DIST	
DOCU	0018	A	PUN	00001553	001	NONE	10/30	16:05:00	IODF88	WORKIODF	DOCU

You can see that the spool ID of the IODF called IODF88 WORKIODF is 0018.

**iodf**

is the file ID of the receiving IODF (filename filetype filemode).

**REPlace**

replaces an existing IODF.

**Example 1:**

```
cbdsimp 0018 iodf88 workiodf a
```

would import the reader file with the spool ID 0018 as work IODF IODF88 WORKIODF A.

## Export an IODF (CBDSEXP)

This HCD function sends an IODF to another system, either z/VM or z/OS. To export an IODF on z/VM, use the REXX utility **CBDSEXP**, as shown in Example 1 on page 161.

If you want to send an IODF to an unattended z/OS system, you have to allocate a file with DD name HCD\_CNTL. From this file, HCD extracts information to set up the JCL to run on the unattended target system. You have to modify or adapt the JOB statement, JES routing statement(s), and JOBLIB information in this file before you call the export utility.

This function is invoked by passing the following parameter string.

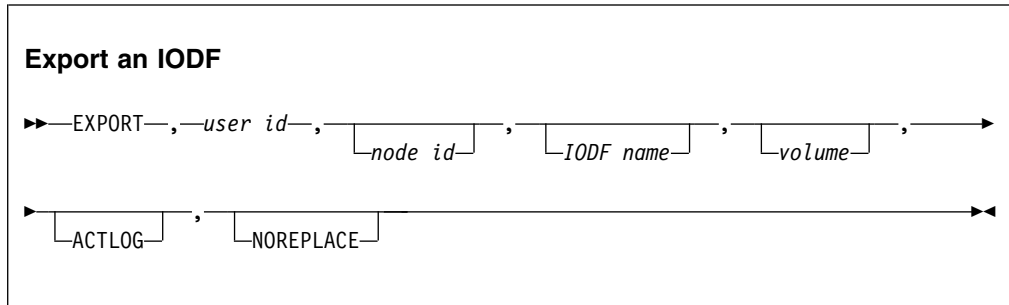

### user id

Specifies the user ID of the target, or a nickname (nickname only if the IODF is not sent to an unattended z/OS system).

### node id

Specifies the node ID of the target system, but only if the IODF is not sent to an unattended target system (otherwise it is ignored in favor of information provided by the JCL).

### IODF name

Specifies the name of the target IODF. Default is the name of the source IODF prefixed with the specified target user ID. This parameter is only applicable if the IODF is sent to an unattended z/OS system, otherwise it is ignored.

### volume

Specifies the volume serial number of the DASD on which the target IODF is created if it does not exist. This parameter is only applicable if the IODF is sent to an unattended z/OS system, and the IODF file is not managed by SMS, otherwise it is ignored.

### ACTLOG

Specifies that the appropriate activity log file should also be sent. If this parameter is missing, or the target is an unattended MVS system, it is not sent.

### NOREPLACE

For unattended exports, this keyword provides overwrite protection for an IODF at the target system with the same name as the IODF to be exported.

FILEDEF statements are required for the following files when invoking HCD:

DD name	Description	req/opt
HCDLOAD	HCD load module	required

DD name	Description	req/opt
HCDIODFS	IODF to be exported	required
HCDCNTL	CMS file containing the JOB statement, the JES routing statement(s) and the JOBLIB information for sending the IODF to an unattended z/OS system.	required
HCDMLOG	HCD Message Log file	required
HCDPROF	HCD profile	optional
HCDTRACE	Trace file	optional

## Utility CBDSEXP

The REXX utility **CBDSEXP** exports an IODF by sending it to another node/user ID. The receiving node sends an acknowledgement to the sender.

### CBDSEXP Invocation Format:

```

▶▶—CBDSEXP—iodf—userid—┬─nodeid─┬─unatt─┬─target_name─┬─target_volume─▶▶

```

where

#### **iodf**

is the file ID of the IODF to be exported (filename filetype filemode).

#### **userid**

is the user ID (or nickname) to which the IODF is sent

#### **nodeid**

is the node ID for which the specified user ID is defined. It must be '\*' if a nickname is specified with parameter **userid** and you want to export to an unattended z/VM or z/OS system.

#### **unatt**

specify **U** to send the IODF to an unattended z/OS system. (In this case, file MVSJCL CNTL on the target system must hold the import JCL).

#### **target\_name**

specifies the IODF name if it is sent to an unattended z/OS system (if it is a production IODF with file type PRODIODF, then the default is: `userid.iodffilename`, otherwise the default is: `userid.iodffilename.iodffiletype` ).

#### **target\_volume**

is the volume ID on an unattended z/OS system, where the IODF is being created if it does not yet exist, and the volume is not SMS managed.

Specify an \* for, or omit optional parameters. Then they are defaulted.

### Example 1:

The following example sends IODF99 WORKIODF A to user ID JACK on another z/VM system BOEVM3.

```
cbdsexp iodf99 workiodf a jack boevm3
```

### Example 2:

The following example exports IODF IODF99 WORKIODF A to the user ID JACK on an unattended MVS system BOETST1 to be stored on volume HCDUSR.

```
cbdsexp iodf99 workiodf a jack boetst1 u jack.iodf99 hcdusr
```

On the sender system, a file called MVSJCL CNTL must exist containing the following import JCL:

```
//VMXMIT JOB (3141), 'JACK', CLASS=A, MSGCLASS=H, MSGLEVEL=(1,1),  
// USER=JACK, PASSWORD=JACKS7PW  
/*ROUTE XEQ BOETST1
```

**Note:** You can replace the /\*ROUTE statement by the /\*XMIT statement.

```
/*XMIT XEQ BOETST1 DLM=xx
```

When you use the DLM parameter with the /\*XMIT statement, you specify a two-character delimiter to terminate the data being transmitted. (For the end of the records to be transmitted, the default is /\* in the input stream.)

## Activate a Configuration (CBDSACT)

This HCD function allows you to dynamically make changes to a running configuration, that is, to change from a currently active configuration to some other configuration that is to be made active without the need to POR or IPL the system.

In order to perform that function you must be enabled for class B commands.

This function is invoked by passing the following parameter string:

### Activate a Configuration

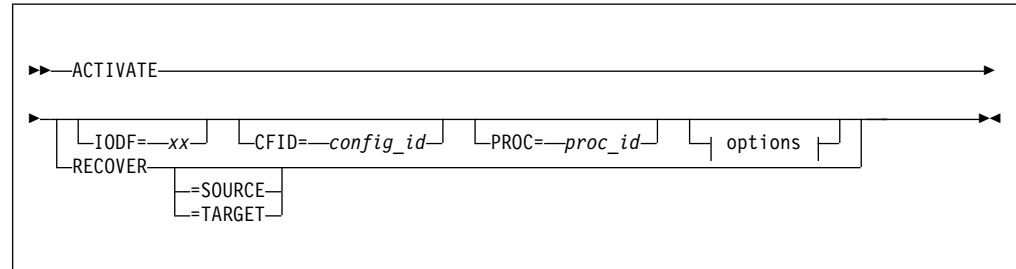

*options:*

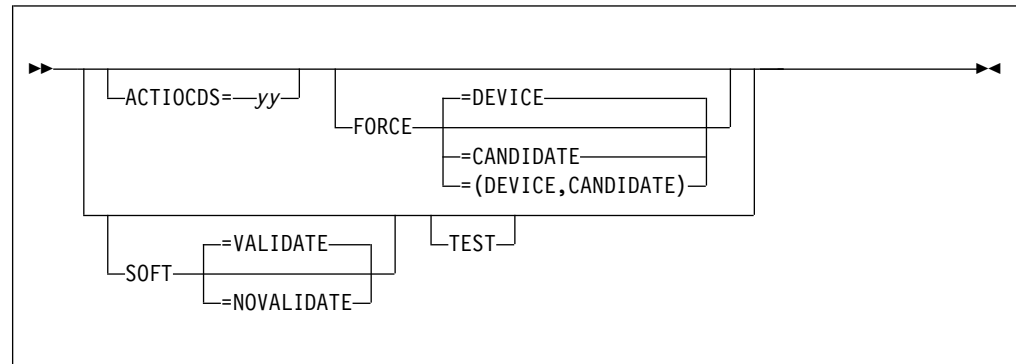

#### ACTIVATE

Indicates that the activate function (configuration change) is to be performed by HCD

#### IODF=

Key word that specifies the two-character suffix of the file name (IODFxx) of the IODF that is to be activated (target IODF). If omitted, the IODF name will be defaulted to the file name of the currently active IODF.

#### CFID=

Key word that specifies the up to 8 byte configuration ID which indicates the operating system name in the target IODF to be activated. If omitted the default is determined as follows:

- the configuration ID of the target IODF if there is only one, else
- the currently active configuration ID if it is available in the target IODF, else
- blank, if the currently active configuration ID is not available in the target IODF.

**PROC=**

Optional keyword that contains the 8 byte processor ID which indicates the processor definition in the target IODF to be activated. If omitted, the current processor ID is used as the default.

**ACTIOCDs**

Specifies the two-character IOCDs name that is to be written for the activated processor configuration. Upon successful completion of the **ACTIVATE** command, the default IOCDs for the next power-on-reset will be yy.

When you specify **ACTIOCDs**, you cannot specify **TEST**.

**FORCE**

Optional keyword that indicates that the system is allowed to delete hardware resources that might offset other partitions. If **FORCE** is not specified, then only adds and modify adds will be allowed. You must specify **FORCE** if you wish to activate a target IODF to delete one or more I/O components. You can also specify **FORCE** to activate a target IODF to delete a logical partition from a device candidate list. These deletions may be explicit or implicit due to changes in the definitions for some I/O components. When you specify **FORCE**, you cannot specify **SOFT** or **TEST**.

You can specify the following suboptions:

**DEVICE**

Delete one or more I/O components, and do either of the following:

- Delete no logical partitions from the access or candidate list of a channel path.
- Delete one or more logical partitions from the access or candidate list of a channel path offline to all of those logical partitions. IBM recommends that you take the channel path offline before issuing the command.

**CANDIDATE**

Delete no I/O components, and delete one or more logical partitions from the access or candidate list of a channel path online to any of those logical partitions. IBM does not recommend this action.

**DEVICE,CANDIDATE**

Delete one or more I/O components, and delete one or more logical partitions from the access or candidate list of a channel path online to any of those logical partitions. IBM does not recommend this action.

**SOFT** Specifies a dynamic change to the software I/O configuration, which updates the I/O configuration only to the operating system. No hardware changes are attempted. However, you may specify whether hardware validation is requested (**VALIDATE**, **NOVALIDATE**). To change a software and hardware I/O configuration dynamically, omit the **SOFT** keyword. When you specify **SOFT**, you cannot specify **FORCE**.

You can specify the following suboptions:

**VALIDATE**

When you specify **SOFT** without any parameters, it is the same as specifying **SOFT=VALIDATE**. This allows you to specify that the

system is to validate that any specified hardware elements to be deleted are offline and available, and that there is sufficient HSA space available to accommodate the hardware changes. When a dynamic change is made to the I/O configuration for a processor complex, a change to the software I/O configuration is performed for the first N-1 logical partitions, followed by a hardware and software change for the Nth logical partition. By specifying the **SOFT** keyword (or **SOFT=VALIDATE**) when changing the I/O configuration on the N-1 logical partitions, you can determine early on whether there will be sufficient HSA space available for the subsequent software and hardware I/O configuration changes on the Nth logical partition.

**NOVALIDATE**

indicates that no validation of hardware changes is to be done.

**TEST** Optional keyword that specifies test mode. It is mutually exclusive to the **FORCE** keyword. The configuration is not actually changed. Only checks will be done whether a dynamic change will probably be successful. *Warning:* If the **ACTIVATE** command is executed with the **TEST** option and no errors are detected, there is still no guarantee that configuration will be activated when the **ACTIVATE** command is actually invoked.

The system checks include whether:

- the dynamic change will fit into the current HSA
- the target IODF exists
- the target IOCDS is a valid data set
- the device support code supports devices being dynamically added or deleted
- the devices to be deleted are offline
- the subchannels of the devices to be deleted are offline

If you are performing a full dynamic activate, the system provides a list showing which channels and devices will be added, deleted, or changed during activation.

**RECOVER**

Specifies that recovery from an activation failure is to be done. This parameter allows you to continue a dynamic change that did not complete due to a hardware or software failure. You can specify:

**SOURCE**

to retry the original I/O configuration (source or current IODF).

**TARGET**

to retry the new I/O configuration (target IODF).

The following FILEDEF statements are required:

DD name	Description	req/opt
HCDLOAD	HCD load module	required
HCDMLOG	HCD Message Log file	required
HCDPROF	HCD profile	optional
HCDTRACE	Trace file	optional

## Utility CBDSACT

The REXX utility *CBDSACT* performs a dynamic software reconfiguration by activating the specified production IODF.

### CBDSACT Invocation Format:

```
▶▶—CBDSACT—prodfn—┌id1┐┌id2┐┌id3┐┌(options)┐▶▶
```

where

#### **prodfn**

is the file ID of the production IODF (filename). The file type must be PRODIODF, the file mode defaults to \*.

#### **id1**

is the ID of the processor configuration to be activated. The default is the ID of the currently active processor configuration.

#### **id2**

is the z/VM I/O configuration ID to be activated. The default is the ID of the currently active configuration.

#### **id3**

is the IOCDS to be written and switched to. The default is that no IOCDS is written and switched to.

#### **options**

##### **SOFTval**

Only software changes are to be activated. Hardware changes are validated.

##### **SOFTNOval**

Only software changes are to be activated. Hardware changes are not validated.

**TEST** Specifies that no real activation is to be done, changes are only tested.

##### **FORCEdev**

FORCE DEVICE: Hardware deletes are possible in different logical partition and deletes of logical partition (LPAR) access of a channel path OFFLINE to these LPARs.

##### **FORCECAN**

FORCE CANDIDATE: Delete logical partition (LPAR) access of a channel path ONLINE to these LPARs.

##### **RECover**

Specifies that recovery from an activation failure is to be done. This parameter lets you continue a dynamic change that did not complete due to a hardware or software failure.

##### **RECSrce**

Specifies to retry the activation from the original I/O configuration (source IODF).

**RECTarg**

Specifies to retry the activation from the new I/O configuration (target IODF).

Specify an \* for, or omit optional parameters. Then they are defaulted.

**Example:**

```
cbdsact iodfc1 ct1vm vmos a1
```

activates the processor configuration CT1VM and operating system configuration VMOS from the production IODF called IODFC1 PRODIODF . In addition it writes IOCDS A1 and switches to it for the next POR.

## Manage Configuration Packages (CBDSDPKG)

The REXX utility *CBDSDPKG* allows the HCD user to specify:

- A source production IODF
- A new target production IODF
- A target user ID and node ID
- Control files for processor, OS and switch configurations.

This processor, OS, and switch configuration information will be extracted from the source IODF and packaged in the target IODF. The target IODF is then sent to the specified node/user ID. Note that this function does not require the definition of a configuration package in the IODF.

In order to use *CBDSDPKG*, the user must be enabled for class G commands.

No FILEDEF statements are required to use this REXX utility. <<Also like CBDSRDEV? True here?>>

### Utility CBDSDPKG

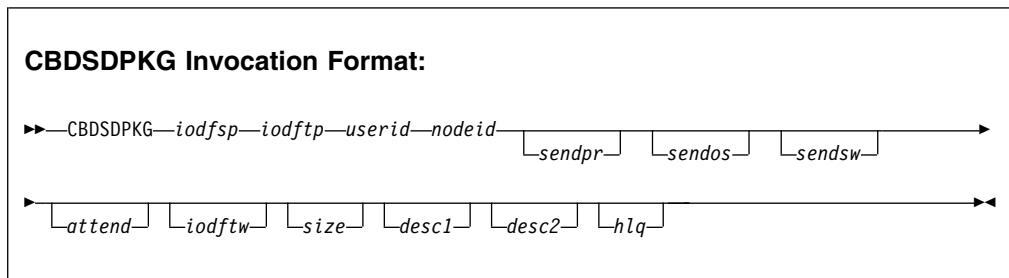

where

#### **iodfsp**

is the file name of source production IODF.

#### **iodftp**

is the file name of target production IODF.

#### **userid**

is the target user ID.

#### **nodeid**

is the target node ID.

#### **sendpr**

is the list of processor configurations to be passed via the file DPKGPR CNTL, as follows:

- 1** Processor configurations included.
- 0** No processors included.

If unspecified, the default is 0.

If 1 is specified but no DPKGPR CNTL file is passed, the default is all processors.

#### **sendos**

is the list of OS configurations to be passed via the file DPKGOS CNTL, as follows:

- 1** OS configurations included.
- 0** No OS configurations included.

If unspecified, the default is 0.

If 1 is specified but no DPKGOS CNTL file is passed, the default is all OS configurations.

**sendsw**

is the list of switch configurations to be passed via the file DPKGSW CNTL, as follows:

**1** Switch configurations included.

**0** No switch configurations included.

If unspecified, the default is 0.

If 1 is specified but no DPKGSW CNTL file is passed, the default is all switch configurations.

**attend**

is one of the following:

**UNATT**

The target system runs unattended.

**ATT** The target system runs attended.

If unspecified, the default is ATT.

**iodftw**

is the file name of the temporary work IODF. If unspecified, the default is the *iodftp* value specified above.

**size**

is the number of records for the target IODF. If unspecified, the default is 1024.

**desc1**

is the build production IODF descriptor 1. If unspecified, the default is the *userid* value specified above.

**desc2**

is the build production IODF descriptor 2. If unspecified, the default is the *iodftp* value specified above.

**hlq**

is the HLQ of the IODF when sending to an MVS system. If unspecified, the default is *userid*.

**Example:**

```
cbdsdpkg iodf02 iodf04 jack boevm3 1 0 0
```

using control file DSPKPR CNTL containing the two lines:

```
PROC01  
PROC04
```

creates IODF04 PRODIODF from IODF02 PRODIODF, which contains only processor configurations PROC01 and PROC04 with unchanged processor tokens. This production IODF is sent to user jack at system boevm3.

Specify an \* for, or omit optional parameters. Then they are defaulted.

This utility will provide command help if invoked as CBSDPKG ? or as CBSDPKG without parameters.

## Generate I/O Configuration File from Control Blocks (CBDSRDEV)

The REXX utility *CBDSRDEV* creates a file containing the current CP I/O configuration extracted from the active VM system (or more exactly, from the RDEV control blocks). *CBDSRDEV* invokes the CMS module *CBDMCONF*.

*CBDMCONF* creates the CP I/O configuration file which you can use as input to *CBDSMIGR* in order to migrate it into an IODF. *CBDMCONF* uses the following return codes:

- 00      successful completion
- 08      error during FILE WRITE function
- 12      user not authorized to issue LOCATE command
- 16      OPCTB module not found or other locate error

In order to use *CBDSRDEV*, the user must be enabled for class C or E commands.

No FILEDEF statements are required to use this REXX utility.

### Utility CBDSRDEV

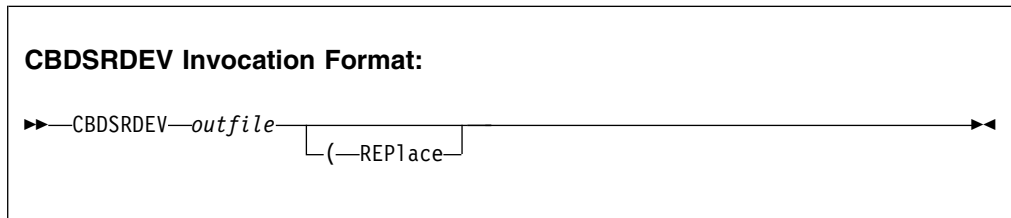

where

#### **outfile**

is the file ID of the output I/O configuration file. This parameter actually consists of three positional parts: filename filetype filemode. This parameter is optional. If omitted, the following defaults apply:

- filename = CBDMCONF
- filetype = RDEVLIST
- filemode = A

#### **REPlace**

replaces an existing file with the same file ID as *outfile*.

Specify an \* for, or omit optional parameters. Then they are defaulted.

#### **Example:**

Invoking the utility as:

```
cbdsrdev  
or:  
cbdsrdev CBDMONF RDEVLIST A
```

creates file CBDMONF RDEVLIST A containing the currently active CP I/O configuration.

This utility will render HELP if invoked like CBDSRDEV ?.

## List of Standard DD Names

Standard DD names, that define the files used by z/VM HCD, are used on the FILEDEF commands in the REXX utilities. These names are shown in Table 8. If you want to change these names, you must create a list of alternate DD names, using the standard format for such a list.

Table 8. Standard DD names Used by HCD

	DD name	HCD Task	File Contents
1	not used		
2	not used		
3	not used		
4	HCDLIB	Migration	Assembler macro library
5	HCDIN	Migration	Migration input
6	HCDPRINT	Migration	Migration log (messages)
7	not used		
8	HCDUT1	Migration	Assembler work file
9	HCDUT2	Migration  Activity Log	Modified IOCP, and HCPRIO input to assembler  Target activity log during copy
10	HCDUT3	Migration	Assembler output (object) data
11	not used		
12	HCDTERM	Migration	Assembler and loader messages
13	not used		
14	not used		
15	not used		
16	not used		
17	HCDRPT	Query/print	HCD reports
18	HCDALOG	All	Activity log
19	not applicable		
20	HCDASMP	Migration	Assembler output listing
21	HCDDECK	Activation	IOCP and HCPRIO input file (output)
22	HCDIODFP	All	First IODF
23	HCDIODFS	Maintain IODF	Source IODF (for COPY, for example)
24	HCDIODFT	Maintain IODF	Target IODF
25	HCDPROF	Tailor HCD defaults	HCD profile definitions
26	HCDMLOG	All	Message log
27	HCDTRACE	All	Trace file (if trace is activated)
28	HCDCNTL	Activation  Maintain IODF	Control file for Build IOCDs  Control file for Build IOCP input file JCL file for Import/Export IODF IODF description List of configurations for Build I/O Configuration Statements

---

## List of Alternate DD Names

If used, this optional list, must start on a halfword boundary that is not also a fullword boundary.

- The first two bytes must contain a binary count of the number of bytes in the rest of the list.
- The rest of the list specifies alternate DD names that you wish to use in place of the standard DD names.
  - DD names in the alternate list must appear in the same sequence as they appear in the standard list.
  - Each name must be eight characters long. If a name contains fewer than eight characters, pad it with blanks. If you omit an alternate DD name, set that entry in the alternate DD names list to binary 0.
  - Entries in the alternate DD names list that correspond to empty entries in the standard DD names list must be set to binary 0.

**PI end**



## Chapter 13. Configuration Reports

This chapter shows examples of the configuration reports that can be produced by HCD.

- Textual configuration reports
- Graphical configuration reports
- IODF compare reports

### Textual Configuration Reports

This section shows examples for textual configuration reports. “Print Configuration Reports” on page 69 lists the different report types available and describes how to produce them.

### Channel Subsystem Reports

#### Processor Summary Report

PROCESSOR SUMMARY REPORT						TIME: 15:29	DATE: 2007-03-15	PAGE A-	1
PROCESSOR ID	TYPE	MODEL	CONFIG. MODE	SERIAL NUMBER	DESCRIPTION	----- SNA ADDRESS -----		LSYSTEM	
						NETWORK NAME	CPC NAME		
ERV01WWW	2094	S38	LPAR	1212122094	mix system	ZZZZZZZZ	ERV01	ERV01	
ERV0201	9672	ZX7	LPAR	4434349672	old system 1	IBM390PS	ERV0201		
ERV0202	9672	ZX7	LPAR	1111119672	old system 2	IBM390PS	ERV0202		
ERV05A1	2094	S28	LPAR	9912992094	Standalone FCTC CTC/CNC	IBM390PS	ERV05A1		
ERV05A2	2094	S54	LPAR	9929912094	standalone FCTC CTC/CNCproc	IBM390PS	ERV05A2		
NET01	2096	R07	LPAR	3322332096	Network System	ZZZZZZZZ	NET01		

PROCESSOR ID	----SUPPORT LEVEL----	DESCRIPTION
ERV01WWW	H050331	XMP, Basic 2094 support
ERV0201	H990531	FCV, OSD, OSE, IC, ICB, CF, OSA, ESCON, Parallel
ERV0202	H990531	FCV, OSD, OSE, IC, ICB, CF, OSA, ESCON, Parallel
ERV05A1	H050331	XMP, Basic 2094 support
ERV05A2	H050331	XMP, Basic 2094 support
NET01	H060930	XMP, 2096-R07 support

Figure 32. Example of a Processor Summary Report

- CONFIG. MODE      Indicates the operation mode in which a processor may operate. This mode must be:
- LPAR**      The processor is logically partitioned. Several operating systems may run concurrently in different partitions of the processor.
- SNA ADDRESS      The SNA Address consists of Network name and CPC name and associates the CPC and the processor definition in the IODF.
- SUPPORT LEVEL    Shows the ID of the processor support level and an enumeration of the provided functionality.

#### Channel Subsystem Summary Report

Only XMP processors will have a channel subsystem report which shows the defined channel subsystems.

PROCESSOR ID P2964		TYPE 2964		MODEL N96					
CSS ID	DEVICES IN SS0		DEVICES IN SS1		DEVICES IN SS2		DEVICES IN SS3		DESCRIPTION
	MAXIMUM	ACTUAL	MAXIMUM	ACTUAL	MAXIMUM	ACTUAL	MAXIMUM	ACTUAL	
0	65280	16825	65535	0	65535	0	65535	0	
1	65280	16709	65535	0	65535	0	65535	0	
2	65280	14587	65535	0	65535	0	65535	0	
3	65280	15239	65535	0	65535	0	65535	0	
4	65280	14	65535	0	65535	0	65535	0	CSS 4 of P2964
5	65280	0	65535	0	65535	0	65535	0	

Figure 33. Channel Subsystem Summary Report

**Note:** This report and the following channel subsystem reports show the processor token only if the IODF is a production IODF.

### PCIe Function Summary Report

The PCIe Function Summary Report provides an overview of the defined PCIe functions for the specified processor.



## CHID Summary Report

The CHID summary report provides an overview of all CHIDs defined for channel paths and PCIe functions of a processor and also gives an overview of the defined PNET IDs for the CHIDs.

CHID SUMMARY REPORT										TIME: 09:23 DATE: 2015-11-26 PAGE A- 3				
PROCESSOR ID		P2964V2		TYPE 2964		MODEL N30		CONFIGURATION MODE: LPAR						
CHID	VF	CHPID	FID	TYPE	SWITCH	CSS Numbers					PNET-1	PNET-2	PNET-3	PNET-4
030		30		FC	17	0	1	2	3	4				
031		31		FC	17	0	1	2	3					
110	1	0010		ROCE		0		2			PNETID1	PNETID2		
1C4		A0		OSD					3					
320		A0		OSD		0								
391		50		FCP		0	1	2	3					
393		51		FCP		0	1	2	3					
3A1		A0		OSD				2						
3B0		86		OSD		0	1	2	3					
3C0		94		OSE		0								
400		2010		RCE		0		2						
401		2110		RCE		0		2						
4C2		C2		OSD		0	1	2		4	5			
4C3		C3		OSD		0	1	2		4	5			
4FE	30	0021		ROCE		0		2			PNETID1	ID2		
4FE	31	0020		ROCE		0		2			PNETID1	ID2		
4FF	5	0FF0		ZEDC-EXPRESS		0			3					
4FF	15	0FFF		ZEDC-EXPRESS		0			3	4	5			
7C0	10	1110		ISM		0					NET1			
7C0	11	1111		ISM		0					NET1			
7C0	12	1112		ISM		0					NET1			
7E0		F5		IQD		0	1	2	3	4	5			
7E5		FE		IQD		0	1	2	3					
*		76		OSD				2	3					
*		94		OSE				2						
*		94		OSE					3					
*		FA		IQD		0	1	2	3	4	5			
0F/2		10		CIB		0								
0F/2		11		CIB		0								
11/1		C5		CS5						4				
36/1		C4		CS5						4				

TOTALS FOR CHANNEL CARDS															
HCA		FICON		OSA					INTERNAL		PCIE				
CIB	CS5	FC	FCP	OSC	OSD	OSE	OSM	OSN	OSX	ICP	IQD	ISM	RCE	ROCE	ZEDC
1	2	2	2	0	7	3	0	0	0	0	3	1	2	2	1

CALCULATIONS OF TOTAL CHANNEL CARD VALUES:  
HCA - A PHYSICAL ADAPTER (AID) WITH MULTIPLE PORTS IS COUNTED AS ONE ADAPTER  
PCIE - A CHANNEL (CHID) WITH SEVERAL VIRTUAL FUNCTIONS (VF) IS COUNTED AS ONE ADAPTER

Figure 35. CHID Summary Report

## Partition Report

PROCESSOR ID	PROC1	TYPE	9021	PARTITION MODEL 900	REPORT	TOKEN: PROC1	92-07-03 15:36:27 HCD	TIME: 11:52 DATE: 1997-03-02	PAGE B- 1
PARTITION NAME	NUMBER	USAGE	DESCRIPTION						
PROD1	1	OS	First production partition						
PROD2	2	OS	Second production partition						
TEST1	3	OS	First test system						
TEST2	4	OS	Second test system						
TEST3	5	CF	CF partition						
TEST4	6	CF/OS	CF/OS partition						

PROCESSOR ID	G33XMP	TYPE	2084	PARTITION MODEL B16	REPORT	TIME: 12:57 DATE: 2003-01-15	PAGE B- 3
PARTITION NAME	NUMBER	USAGE	DESCRIPTION				
TCSS0LP2	2	CF/OS	OS/CF Partition number 2 CSS0				
TCSS0LP3	3	OS	OS Partition number 3 CSS0				
*	4	CF/OS	reserved Partition number 4 CSS0				

PROCESSOR ID	G33XMP	TYPE	2084	PARTITION MODEL B16	REPORT	TIME: 12:57 DATE: 2003-01-15	PAGE B- 4
PARTITION NAME	NUMBER	USAGE	DESCRIPTION				
LIN1	7	OS	Linux				
LNXXM10	A	OS	Linux				
LNXXM3	6	OS	Linux				
LNXXM4	8	OS	Linux				
LNXXM9	9	OS	Linux				

PROCESSOR ID	G33XMP	TYPE	2084	PARTITION MODEL B16	REPORT	TIME: 12:57 DATE: 2003-01-15	PAGE B- 5
PARTITION NAME	NUMBER	USAGE	DESCRIPTION				
TCSS2LP2	2	OS	OS Partition number 2 CSS2				
TCSS2LP5	5	OS	OS Partition number 5 CSS2				

...

Figure 36. Example of a Partition Report

**NUMBER** Is the partition number (MIF ID). This information is printed only for EMIF capable processors.

**USAGE** Specifies the usage type of a partition: CF indicates a partition supporting coupling facility. OS indicates a partition running an operating system. CF/OS indicates a partition supporting coupling facility or running an operating system.

**Note:** This report and the following channel subsystem reports show the processor token only if the IODF is a production IODF.

## IOCDS Report

The IOCDS data are retrieved from the IODF. This is indicated by an IOCDS status line at the end of the report.

PROCESSOR ID	CFS	TYPE	9672	IOCDS MODEL RX6	REPORT	TIME: 00:06 DATE: 2005-10-18	PAGE C- 1
IOCDS NAME	FORMAT	STATUS	IOCDS/HSA	IOCDS/Proc	Protect	DATE	TIME
A0	LPAR					2004-11-12	06:14
A1	LPAR					2004-03-03	16:49
A2	LPAR					2004-04-01	00:01
A3	LPAR					2004-10-22	11:45

Figure 37. Example of an IOCDS Report

NAME	Represents the user-defined name of the IOCDS (derived from the MSG1 parameter)
FORMAT	IOCDS format (LPAR only)
STATUS	Indicates the status of the IOCDS: <i>Alternate, POR, Invalid</i>
Token Match - IOCDS/HSA	Indicates whether the IOCDS token matches the current HSA token
Token Match - IOCDS/Proc	Indicates whether the IOCDS token matches the current processor token in the IODF
Write Protect	Indicates whether the IOCDS is write-protected ( <i>Yes</i> ) or not ( <i>No</i> ), or currently write-protected because it is the POR IOCDS ( <i>Yes-POR</i> ).
Last Update DATE/TIME	Time stamp of IOCDS creation time
IOCDS Configuration Token Information	is the configuration token information stored in the support element and shows the relationship between the IOCDS and the production IODF from which it was created.

## **Channel Path Summary Report**

If applicable, for spanned channels, there is a separate sub-report after the partition table of a processor which shows the connection of spanned channel paths to channel subsystems.



CHID AID/P	For external channels: designates the physical channel identifier (PCHID) or, if applicable, designates the HCA adapter ID (AID) and the HCA port (P). For internal channels: designates the virtual channel identifier (VCHID).
DIS QP	Indicates whether queue prioritization is disabled.
MFS KB	Designates the maximum frame size in KB.
	For channels of type IQD, this field also indicates whether or how this channel exploits the extended IQD function, as follows: <b>blank</b> indicates the HiperSockets function <b>X</b> indicates IEDN support (IQDX) <b>B</b> indicates bridge support
MNGD	Indicates whether the channel path is managed.
I/O CLUSTER	The I/O cluster name for managed channel paths.
DYN. SWITCH	Designates the switch holding the dynamic connection.
SWITCH ID	Designates the switch the channel is physically plugged in (entry switch).
PORT	Designates the entry port on the entry switch.
MODE	Operation mode of the channel path.

## Channel Path Detail Report

The Channel Path Detail Report lists the channel paths defined per processor with their attributes and attachment information.

In addition, the switch connections on the path between the CHPID and the control unit are shown if they can be determined by HCD. The entry switch and port of the CHPID are always shown.

For an entry switch of a CHPID which is defined as a dynamic switch, the control unit port is shown if it is compatible with the link address defined for the CHPID. For an entry switch of the CHPID which is defined as a dedicated switch, the control unit port or the ports connecting the switches are only shown if switch configurations are defined which allow HCD determining a valid path between CHPID and control unit.

In case of chained switches, the first print line for a channel path shows the switch the channel path is physically plugged in. The second print line shows the switch the control unit is connected to. In addition, the first print line shows the ID of the switch with the dynamic connection.

Each attached control unit of a specific channel path is separated by a line.

The first print line for an attached control unit shows the first unit address range defined for the control unit. If there are more unit address ranges defined for a control unit, these are shown in the following print lines. Together with the unit address range(s) of the control unit the attached devices of the control unit are shown grouped according to device types and consecutive numbers and unit addresses. The report shows the starting device number and range of the device group. The unit address describes the address of the first device in the range.

For FICON switches, the dynamic switch ID is empty. The control unit port ID is shown as a two-byte port address (the port ID prefixed by the switch address) when used in a cascaded switch environment, or as a one-byte port address otherwise. For cascaded FICON switches, only the channel path port ID and the control unit port ID are shown, but no connection between the switches.

**Note:** For a Coupling Facility control unit, all CF devices attached to this control unit are listed, not only those devices that are defined for the connected coupling facility channel path described in the row. To view exactly those devices that are defined for the coupling facility channel path, print the CF Channel Path Connectivity Report.

CHANNEL PATH DETAIL REPORT											TIME: 12:57 DATE: 2010-10-21 PAGE E- 1					
PROCESSOR ID R35		TYPE 2817			MODEL M49		CONFIGURATION MODE: LPAR									
CSS ID 0					---- SWITCH ----						UNIT ADDR		UNIT			
CHPID	PCHID AID/P	TYPE	MNGD	MODE	ID	PR PN	CU PN	DYN ID	--- CONTROL UNIT ---	CU-ADD	PROTOCOL	RANGE FROM	TO	-- DEVICE --	ADDR START	DEVICE TYPE-MODEL
									NUMBER	TYPE-MODEL				NUMBER, RANGE		
00	5B0	OSD	NO	SPAN					B302	OSA		00	FE	B300,6 B306,42 B330,16 B340,6 B346,42 B370,16	00 06 30 40 46 70	OSA OSA OSA OSA OSA OSA
0C	130	OSC	NO	SPAN					0003	OSC		00	FD	0090,16 1090,4	00 10	3270-X 3270-X
0D	131	OSM	NO	SPAN												
0E	1E1	CFP	NO	SPAN					FFDF	CFP				F0D4,7 F0DB,7		CFP CFP
0F	1E9	CFP	NO	SPAN					FFDF	CFP				F0D4,7 F0DB,7		CFP CFP
12	1F2	CNC	NO	SHR				1A	0690	3590		00	03	0690,4	00	3590
								1A	1A39	3590		00	0F	0A38,2	00	3590
								1A	1A55	3590		00	03	0A54,4	00	3590
30	220	FC	NO	SPAN	10	2A	6140		2000	2107	2	00	9F	2000,160	00	
					10	2A	611A		2800	2107	1	00	FF	2800,40 2828 2829,39 2850,2 2852,6 2858,88 28B0,5 28B5,11 28C0 28C1,8 28C9,7 28D0,48	00 28 29 50 52 58 B0 B5 C0 C1 C9 D0	3390B 3390B 3390B 3390B 3390B 3390B 3390B 3390B 3390B 3390B 3390B 3390A
					10	2A	612F		4001	2107	0	00	FF	4000,96 40A0,16	00 A0	3390B 3390B

Figure 39. Example of a Channel Path Detail Report

- SWITCH ID Designates the entry switch the channel path is physically plugged in. For chained ESCON switches or cascaded FICON switches, a second line is shown with the ID of the switch to which the control unit is connected.
- SWITCH PR PN Designates the entry port of the entry switch. In case of an ESCON chained switch, it designates the entry port of the chained switch.
- SWITCH CU PN Designates the port the control unit is connected to. In case of an ESCON chained switch, it designates the port of the entry switch to which the chained switch is connected. For a cascaded FICON switch, the port ID is prefixed by the switch address.
- SWITCH DYN ID For an ESCON environment, it designates the switch holding the dynamic connection.

## CF Channel Path Connectivity Report

For XMP processors, there will be a single CF Channel Path Connectivity Report. The CHPID numbers are prefixed by the channel subsystem ID. For example 1.0C denotes CHPID 0C from CSS 1. If a spanned channel path is used, the CHPIDs are reported from all channel subsystems together with the accessed partitions in the channel subsystems.

CF CHANNEL PATH CONNECTIVITY REPORT										TIME: 13:06 DATE: 2010-10-21 PAGE F- 1				
PROCESSOR ID R35		TYPE 2817		MODEL M49		CONFIGURATION MODE: LPAR								
SOURCE				DESTINATION				SOURCE		DESTINATION		CNTL TYPE		
CHPID	TYPE	MODE	ACCESS/CAND LIST	PROCESSOR ID	TYPE-MODEL	CHPID	TYPE	MODE	ACCESS/CAND LIST	CNTRL UNIT	DEVICE NUM,RANGE		CNTRL UNIT	DEVICE NUM,RANGE
0.0E	CFP	SPAN	IRD7	H05	2097-E26	3.0E	CFP	SHR	*IRD7CF3	FFDF	F0D4,14			CFP
1.0E		N	IRD8											
0.0F	CFP	SPAN	IRD7	H05	2097-E26	3.0F	CFP	SHR	*IRD7CF3	FFDF	F0D4,14			CFP
1.0F		N	IRD8											
0.F7	CFP	SPAN	IRD7	ECL2	2097-E40	0.81	CFP	SPAN	*IRD4CFF	FFD8	DFBA,7	FFD4	DFB3,7	CFP
1.F7			*IRD6	(C)		3.81			D0E (C)		DFE4,7		DFDD,7	
0.F8	CFP	SPAN	IRD7	H05	2097-E26	3.06	CFP	SHR	*D3F (C)	FFD6	DF9E,7	FFD0	DF97,7	CFP
1.F8			*IRD6	(C)							DFAC,7		DFA5,7	
2.F8			DWB1											
3.F8			DWB2											

LEGEND FOR ACCESS/CAND LIST:  
 \* - PARTITION IS OF TYPE CF OR CF/OS  
 (C) - PARTITION IS IN CHPID'S CANDIDATE LIST ONLY

Figure 40. Example of a CF Channel Path Connectivity Report

SOURCE/DESTINATION CHPID	The identifier of the source/destination channel path.
SOURCE/DESTINATION TYPE	Is the type of the source/destination channel path.
SOURCE/DESTINATION MODE	Is the operation mode of the source/destination channel path.
SOURCE 0	CHPID is identified as occupied
SOURCE/DESTINATION ACCESS/CAND LIST	Shows those partitions which the source/destination channel path has in its access or candidate list. Partitions in the candidate list are flagged with (C) behind the partition name. Partitions of type CF or CF/OS are prefixed with an *. For example, *D3F (C) and *IRD6 (C) denote coupling facility partitions in the candidate list.
DESTINATION PROCESSOR ID	Is the name of the processor the destination channel path is defined for.
DESTINATION TYPE-MODEL	Is the type-model of the destination processor.
SOURCE CNTRL UNIT	Is the number of the CF control unit used for the source CF channel path connection.
SOURCE DEVICE NUM,RANGE	Are the numbers of the CF devices and ranges of a device group used for the source CF channel path connection.
DESTINATION CNTRL UNIT	Is the number of the CF control unit used for the destination CF channel path connection.
DESTINATION DEVICE NUM,RANGE	Is the number of the starting CF device and range of a device group used for the destination CF channel path connection.
CNTL TYPE	indicates the type of the connecting control unit(s).

**Note:** This report lists exactly the devices that are defined for the CF channel path connection described in the row.

# Control Unit Summary Report

CONTROL UNIT		SERIAL		CONTROL UNIT SUMMARY REPORT		TIME: 16:12 DATE: 2009-02-10 PAGE G- 1		LOGICAL	
NUMBER	TYPE-MODEL	NUMBER	NUMBER	DESCRIPTION	CONNECTED SWITCH	ID.PORT	NUMBER	PATHS	
0003	OSC			CU for OSC Channels					
0070	OSN								
0120	OSA			for all native MVS (also NETMVS)					
0480	3480	11333		TAPES 0480 CT1 BL6	1A.CB				
04B0	FCP			Open FCP 16					
0900	1750			DS6K1 (0900-094F)	80	17.54	17.58	17.5C	17.60
0950	1750			DS6K1 (0950-098F)	80	17.54	17.58	17.5C	17.60
0B20	2105	11111		ESS22 B20 CU2 (3390-3/27)VSE	152	17.45	17.49		
0BC0	2105	11111		ESS22 BC0 CU4 (3390-mix) VSE	144	17.45	17.49		
0C50	2105	11111		ESS22 C50 CU5 (3390-mix) VSE	176	17.45	17.49		
0D80	2107	11222		DS8K0 CU0(D80-DCF) 3390-MIX	80	17.44	17.48	17.4C	17.50
0DD0	2107	11222		DS8K0 CU1(DD0-E1F) 3390-MIX	80	17.44	17.48	17.4C	17.50
0E20	2107	11222		DS8K0 CU2(E20-E3F) 3390-54	32	17.44	17.48	17.4C	17.50
0E40	2107	11222		DS8K0 CU3(E40-E5F) 3390-54	32	17.44	17.48	17.4C	17.50
0E60	2105	11111		ESS22 E60 CU0 (3390-9) VSE	96	17.45	17.49		
0EC0	2105	11111		ESS22 EC0 CU1 (3390-3/27)VSE	152	17.45	17.49		
0F60	2105	11111		ESS22 F60 CU3 (3390-65) VSE	64	17.45	17.49		
1010	2032			McData ED-6064 z/OS					10.FE
1011	2032			McData ED-6140 z/OS					11.FE
1028	FCTC	H053E3F		FCTC H05LP04 to H05LP11 + TRX1					
102A	FCTC	H053E3F2		FCTC H05LP30 to H05LP31					
1128	FCTC	H053E3F		FCTC H05LP04 to H05LP11					
112A	FCTC	H053E3F2		FCTC H05LP30 to H05LP31					
112B	FCTC	H053E3F		FCTC H05LP04 to TRX1					
1240	OSA			OSA (1240-125E,5F)					

Figure 41. Example of a Control Unit Summary Report

CONNECTED SWITCH ID PORT Describes where the CU is physically connected to (switch and port)  
 LOGICAL PATHS Displays the number of defined logical paths per control unit.

## Control Unit Detail Report

The Control Unit Detail Report lists all control units defined in the currently accessed IODF, with their attributes and attachment information.

For each control unit all processors are shown, where the control unit is attached to. For each of those processors, all control units, that are part of the "logical control unit" the currently printed control unit belongs to, are printed. Also, the currently shown control unit is listed again to show information about switch connection, channel path attachment, and attached devices. The information about each logical control unit the currently printed control unit belongs to, is separated by a dotted line.

The switch connection information is shown in the Control Unit Detail Report even if no switch configuration is defined. For example:

If a control unit is connected to a switch, but no complete path is defined through the switch (that means, no valid path is defined through the switch, which allows a dynamic connection) the complete switch connection information with SWITCH ID, CU PN, and PR PN can be determined.

In case of chained switches, the first information in a print line is shown for the switch the control unit is connected to. The second set of switch information is for the switch that the channel path is connected to. Note that this is different from the Channel Path Detail report.

To get information about the switch with the dynamic connection (in case of chained ESCON switches), the Channel Path Detail Report has to be produced.

For each control unit belonging to a logical control unit, the channel path it is attached to, is printed together with the link address (if applicable).

For FICON cascade switching, the link address will be shown as a two-byte display. If a path from the control unit is via cascaded FICON switches, the link between the FICON switches is not shown. Instead, the control unit port of the switch connected to the control unit and the CHPID port of the switch connected to the channel path are shown. If no port connections are defined, switch data is extracted from the dynamic switch and the link address. Port IDs are shown as one-byte port addresses.

The 'DEVICE' column shows the devices which are attached to the control unit printed under column 'CU IN LCU'. If the control unit is attached to more than one channel path, the information about the attached devices is printed together with the last printed channel path. The devices attached to a control unit are grouped according to consecutive number. The report shows the starting device number and range of the device group.

Columns 'LOG. PATHS PER CU' and 'LOGICAL PATHS PER CU PORT' display the number of defined logical paths.

**Note:** For a Coupling Facility control unit, all CF devices attached to this control unit are listed, not only those devices that are defined for the connected coupling facility channel path described in the row. To view exactly those devices that are defined for the coupling facility channel path, print the CF Channel Path Connectivity Report.

CONTROL UNIT DETAIL REPORT														TIME: 16:12	DATE: 2009-02-10	PAGE H-	2
CONTROL UNIT NUMBER	TYPE-MODEL	PROCESSOR. CSS ID	LOG. PATHS		CU IN LCU	IOCL	CU- ADD	SWITCH ID	CU PN	PR PN	-CHAINED/CASC-		CHPID . LINK ADDR	-- DEVICE -- NUMBER,RANGE	LOGICAL PATHS PER CU PORT		
			PER CU	PER CU							SWITCH ID	CU PN				PR PN	
0950	1750	PROC03.1	4	0950		3	17 17	5C 60			14 14	52 4E	35 . 685C 41 . 6860	0950,80	20 20		
		PROC03.2	4	0950		3	17 17	5C 60			14 14	52 4E	35 . 685C 41 . 6860	0950,80	20 20		
0B20	2105	PROC03.0	2	0B20		2	17 17	45 49			14 14	52 4E	35 . 6845 41 . 6849	0B20,152	27 27		
		PROC03.1	2	0B20		2	17 17	45 49			14 14	52 4E	35 . 6845 41 . 6849	0B20,152	27 27		
		PROC03.2	4	0B20		2	17 17	45 49			14 14	52 4E	35 . 6845 41 . 6849	0B20,152	27 27		
		PROC03.3	2	0B20		2	17 17	45 49			14 14	52 4E	35 . 6845 41 . 6849	0B20,152	27 27		
0BC0	2105	PROC03.0	2	0BC0		4	17 17	45 49			14 14	52 4E	35 . 6845 41 . 6849	0BC0,144	18 18		
		PROC03.1	2	0BC0		4	17 17	45 49			14 14	52 4E	35 . 6845 41 . 6849	0BC0,144	18 18		
		PROC03.2	4	0BC0		4	17 17	45 49			14 14	52 4E	35 . 6845 41 . 6849	0BC0,144	18 18		
		PROC03.3	2	0BC0		4	17 17	45 49			14 14	52 4E	35 . 6845 41 . 6849	0BC0,144	18 18		
0C50	2105	PROC03.0	2	0C50		5	17 17	45 49			14 14	52 4E	35 . 6845 41 . 6849	0C50,170	9 9		
		PROC03.1	2	0C50		5	17 17	45 49			14 14	52 4E	35 . 6845 41 . 6849	0C50,170	9 9		
		PROC03.2	4	0C50		5	17 17	45 49			14 14	52 4E	35 . 6845 41 . 6849	0C50,170	9 9		
		PROC03.3	2	0C50		5	17 17	45 49			14 14	52 4E	35 . 6845 41 . 6849	0C50,170	9 9		

Figure 42. Example of a Control Unit Detail Report

PROCESSOR.CSS ID	Designates the processors, and in case of an XMP processor, the channel subsystem to which the CU is attached.
CU IN LCU	Designates which CUs belong to the logical CU.
CU-ADD	Designates the CU address.
SWITCH ID	Designates the switch the CU is connected to.
CU PN	Designates the port the CU is physically connected to.
PR PN	Designates the entry port of the channel (except in the case of chained switches)
CHAINED/CASC (SWITCH ID, CU PN, PR PN)	Designates a possible second switch the CHPID is connected to.
IOCL	Designates I/O concurrency level (same as SHARED in IOCP). Specifies the level of concurrency of I/O requests that the parallel channel path allows for the control unit (CU). 1 One I/O request at a time. (SHARED=Y) 2 Multiple I/O requests at a time. (SHARED=N) 3 IOCL 1 until dedicated allegiance. (SHARED=Y)
CHPID . LINK ADDR	Designates the channel path and the one- or two-byte link address to which the control unit is connected. <i>n</i> (*) in this column indicates that the control unit is connected to <i>n</i> managed channel paths.
DEVICE NUMBER,RANGE	Specifies information about the devices that are attached to the processors by the control unit.
LOGICAL PATHS PER CU PORT	Specifies the number of defined logical paths for all control units connected to a specific port.

## Device Summary Report

The Device Summary Report gives you an overview of the devices defined in the currently accessed IODF and their attaching control units. The devices are grouped according to the same characteristics. The report shows the starting device number and the range of the group.

For multi-exposure devices, the base devices are grouped separately from the non-base exposure devices.

---

DEVICE SUMMARY REPORT			TIME: 16:59	DATE: 1997-10-28	PAGE I-	1
--- DEVICE --- NUMBER,RANGE	DEVICE TYPE-MODEL	ATTACHING CONTROL UNITS	SERIAL NUMBER	DESCRIPTION	VOLSER	
0080,16	3174	0080		Merian SNA Connection		
0090,2	RS6K	0110				
0092,2	RS6K	0112				
0094,2	RS6K	0114				
0096,2	RS6K	0116				
0110,2	RS6K	0110				
0112,2	RS6K	0112				
0114,2	RS6K	0114				
0116,2	RS6K	0116				
01C0	3270-X	01C0		Console Real and Virt.		
01C1,31	3270-X	01C0		Terminal		
0200,64	3390	200A 200B				
0300,32	9345	300A 300B				
0320,32	9345	320A 320B				
0340,32	9345	340A 340B		Real Dasd (9345 340-35f)	MVSLIB	
0360,32	9345	360A 360B		Real Dasd (9345 360-37f)	TS0001	

---

Figure 43. Example of a Device Summary Report

## Device Detail Report

The Device Detail Report lists all devices defined in the currently accessed IODF, with their attributes and attachment information. Each device is shown with the processors to which it is attached. The device - processor attachment attributes are also listed.

For each processor the device is attached to, the CUs for the attachment to the processor, as well as the channel path(s) the CU is attached to, are also listed.

The starting device number and the range of subsequent device numbers are shown in one row. A range value of 1 is omitted.

The Device Detail Report shows a partition matrix which indicates whether a logical partition of a corresponding processor has access to the device either via the channel path access list or the channel path candidate list, and whether a partition is excluded or included via the device candidate list. Devices with a null-device candidate list are excluded from the report.

At the end of the report the totals for the following items are listed for each processor:

- CHPIDS
- SUBCHANNELS
- PHYSICAL CONTROL UNITS
- LOGICAL CONTROL UNITS

For the CHPID total, the report lists separate values for the total shared and the total unshared. For the physical CU total, HCD reports the total shared (those attaching to shared channel paths) and the total unshared.

For the subchannel and logical CU totals, the report lists separate values for the shared, unshared, and additional unshared counts that are, respectively, assigned and unassigned to a logical partition. The shared count is the total number assigned to shared channel paths. The generated for LPAR unshared count is the total that would have been generated for a basic IOCDS. The additional unshared count contains the unshared values that were generated for the LPAR IOCDS.

The TOTAL value is the total that would have been contained in the generated IOCDS. The HSA TOTAL is the total that will exist in the HSA after POR. At the completion of POR, the HSA may contain more subchannels and logical CUs than does the IOCDS.

For XMP processors, the following totals are reported:

- CHPIDS
- PHYSICAL CONTROL UNITS
- DEVICES
- LOGICAL CONTROL UNITS

The column CSS TOTAL lists the number of CHPIDs, physical and logical control units and the maximum number of devices that are currently defined for that channel subsystem.

The column IOCDS TOTAL lists the number of CHPIDs, physical and logical control units and the maximum number of devices without definitions caused by over-defined CHPIDs.

Columns HSA TOTAL and HSA LIMIT are not applicable for XMP processors.

The column USER LIMIT lists the maximum number of devices defined by the user for that channel subsystem.

The column SUPPORTED LIMIT lists the maximum number of CHPIDs, physical and logical control units and the maximum number of devices that are supported for the processor for that channel subsystem.



PROCESSOR: EVA  
 CSS ID: 0

PARTITION NUMBER	NAME
1	CF01
2	TRX1
7	G2903
8	TRX08
9	TRX09
D	VSE01
E	G29014
F	G29015

TOTALS FOR CHPIDS, DEVICES AND CONTROL UNITS

	CSS TOTAL	IOCDS TOTAL	USER LIMIT	SUPPORTED LIMIT
CHPIDS	21	21	N/A	256
PHYSICAL CONTROL UNITS	22	22	N/A	8192
DEVICES	3348	3348	8000	64512
LOGICAL CONTROL UNITS	22	22	N/A	4096

...

PROCESSOR: R31SMP

PARTITION NUMBER	NAME
4	RAPOS4
9	RAPMIX9

DEVICE DETAIL REPORT

TIME: 12:57 DATE: 2003-01-15 PAGE J- 10

TOTALS FOR CHPIDS, SUBCHANNELS AND CONTROL UNITS

	SHARED	UNSHARED	ADDITIONAL UNSHARED GENERATED	IOCDS TOTAL	HSA TOTAL	HSA LIMIT
CHPIDS	4	0	N/A	4	N/A	N/A
PHYSICAL CONTROL UNITS	5	0	N/A	5	N/A	N/A
SUBCHANNELS	14	0	0	14	28	524288
LOGICAL CONTROL UNITS	5	0	0	5	10	10240

Figure 45. Example of a Device Detail Report (Part 2 of 2)

# Switch Reports

## Switch Summary Report

---

SWITCH SUMMARY REPORT					TIME: 14:54	DATE: 2001-09-11	PAGE K- 1
SWITCH ID	TYPE	ADDR	SERIAL NUMBER	DESCRIPTION	CU NUMBER	DEVICE NUMBER	INSTALLED PORTS
21	2032	41		switch address 41 fabric a			33
98	9033		55-9999	First switch	0098	0098	9
					0198	0198	
					0298	0298	
99	9032		55-8888	Second switch	0099	0099	29

---

Figure 46. Example of a Switch Summary Report

- CU NUMBER Shows all switch control units attached to the switch CU port of the switch.
- DEVICE NUMBER Shows all switch devices defined for a switch.
- ADDR Shows the switch address, if available.

## Switch Detail Report

If the switch is connected to an XMP processor, the processor ID is qualified with the channel subsystem ID. A spanned channel path is suffixed with an asterisk (\*).

---

SWITCH DETAIL REPORT							TIME: 10:53	DATE: 2001-09-11	PAGE L- 3
SWITCH ID	01	TYPE	9032-3						
PORT	PORT NAME	UNIT	UNIT ID	CONNECTION		UNIT TYPE	OCCUPIED		
AE		CU	053E			3490	NO		
AF	CHAIN_FROM_99	SW	99	PORT	F0	9033	NO		
B0		PR	X9672	CHPID	31	9021-9X2	NO		
		CU	0800			SCTC			
B1	CU_400	CU	0400			3190	NO		
B2	PROCA_CP18						YES		
B3	PROCA_CP19						YES		
B4		CU	0900			3990	NO		
B5		PR	G29.1	CHPID	32	2084-C24	NO		
		CU	1060			SCTC			

---

Figure 47. Example of a Switch Detail Report

- CONNECTION UNIT Specifies the type of the unit the port is connected to. PR = Processor CU = Control Unit SW = Switch
- OCCUPIED Indicates a port connection external to the IODF.

## Switch Configuration Summary Report

---

SWITCH CONFIGURATION SUMMARY REPORT					TIME: 17:24	DATE: 1997-03-02	PAGE M-	1
SWITCH ID	SWITCH TYPE	CONFIG ID	DEFAULT CONNECTION	CONFIGURATION DESCRIPTION				
98	9033	BASIC	ALLOW	night-shift configuration				
99	9032	BASIC2	ALLOW					

---

Figure 48. Example of a Switch Configuration Summary Report

DEFAULT CONNECTION Indicates what state a potential dynamic connection may have (allow or prohibit).

## Switch Configuration Detail Report

The Switch Configuration Detail Report lists all supported ports of a switch with their dynamic connection attributes.

---

SWITCH CONFIGURATION DETAIL REPORT							TIME: 14:59	DATE: 2003-01-17	PAGE N-	1
SWITCH ID	SWITCH TYPE	CONFIGURATION ID	DEFAULT CONNECTION	INSTALLED PORTS						
00	9032-5	SW00ID00	ALLOW	29						
PORT	PORT NAME	BLOCKED	DEDICATED	ALLOWED CONNECTIONS	PROHIBITED CONNECTIONS					
04	PR EVA.0	CHP 00 2084	NO	05-0A,0C-1F	0B					
05	PR EVA.0	CHP 01 2084	NO	04,06-1F						
06	CU 0000	2105	NO	04-05,07-1F						
07	PR EVA.0	CHP 08	NO	10	04-06,08-1F					
08	PR R3ISMP	CHP 00 2066	NO	04-07,09-1F						
09	PR EVA.0	CHP 09	NO	0F	04-08,0A-1F					
0A	PR EVA.0	CHP 10 2084	NO	04-09,0B-1F						
0B	SW 01	PO 04 9032	NO	05-0A,0C-1F	04					
0C	PR EVA.0	CHP 02 2084	NO	04-0B,0D-1F						
0D	CU 0003	3490	NO	04-0C,0E-1F						
0E	CU 0005	2105	NO	04-0D,0F-1F						
0F	SW 01	PO 05	NO	09	04-0E,10-1F					
10	SW 01	PO 06	NO	07	04-0F,11-1F					
11			NO		04-10,12-1F					
12			NO		04-11,13-1F					

---

Figure 49. Example of a Switch Configuration Detail Report

# Operating System Reports

## Operating System Summary Report

---

OPERATING SYSTEM SUMMARY REPORT				TIME: 13:37	DATE: 2010-10-21	PAGE 0-	1
OPERATING SYSTEM ID	TYPE	GEN	DESCRIPTION	D/R SITE OS ID			
-----	-----	---	-----	-----			
OPSYS01	MVS		MVS operating system	OPSYS01D			
OPSYS02	VM		VM operating system				
OPSYS01D	MVS	YES	generated for OPSYS01				

---

Figure 50. Example of an Operating System Summary Report

## VM Device Report

The VM Device Report gives an overview of the devices defined to a VM operating system in the currently accessed IODF.

The devices are grouped according to same characteristics. The report shows the starting device number and the range of a group.

---

OPERATING SYSTEM CONFIGURATION ID:				VM DEVICE REPORT				TIME: 15:19	DATE: 2001-11-05	PAGE P-	1
DEV#,RANGE	TYPE-MODEL	BASE	CT1VM CLASS	VIRT	UIM-NAME	MX	DO	US			
0080	3270		GRAPHIC	Y	CBDUS260						
0081,13	3270		GRAPHIC	Y	CBDUS260						

VM DEVICE REPORT		TIME: 15:19	DATE: 2001-11-05	PAGE P-	2
KEY	KEY DESCRIPTION				
---	-----				
DEV#,RANGE	- DEVICE NUMBER, COUNT OF DEVICES (DECIMAL)				
TYPE-MODEL	- DEVICE TYPE AND MODEL				
BASE	- BASE DEVICE NUMBER FOR MULTIPLE EXPOSURE DEVICES				
CLASS	- VM DEVICE CLASS				
VIRT	- DEVICE IS NOT DEFINED TO CHANNEL SUBSYSTEM				
UIM-NAME	- UNIT INFORMATION MODULE SUPPORTING THE DEVICE				
MX	- DEVICE HAS MULTIPLE EXPOSURES				
DO	- DEVICE IS SUPPORTED DEDICATED-ONLY				
US	- DEVICE IS UNSUPPORTED				
Y	- DEVICE SUPPORTS THIS FEATURE				
BLANK	- DEVICE DOES NOT SUPPORT THIS FEATURE				

TOTAL NUMBER OF DEVICES BY CLASS	
CLASS NAME	DEVICE COUNT
-----	-----
TERMINAL	0
GRAPHIC	14
REMOTE GRAPHIC	0
SPOOL	0
TAPE	0
DASD	0
SPECIAL	0
TOTAL NUMBER OF I/O DEVICES DEFINED BY THIS I/O CONFIGURATION	14

---

Figure 51. Example of a VM Device Report

## VM Device Detail Report

---

OPERATING SYSTEM CONFIGURATION ID: OPSYS02		VM DEVICE DETAIL REPORT		TIME: 15:06	DATE: 2004-10-21	PAGE Q-	1
--- DEVICE ---		DEVICE					
NUMBER,RANGE	TYPE - MODEL	SS	PARAMETER	FEATURE			
0000,16	3390A	0	WLMPAV=YES				
-----							
0100	3278-3		OFFLINE=NO,OFFLINE=NO				
-----							
0200	3279-2		OFFLINE=NO,OFFLINE=NO				
-----							
02D1,4	3390		OFFLINE=NO,OFFLINE=NO,OFFLINE=NO				
-----							

---

Figure 52. Example of a VM Device Detail Report

PARAMETER        Shows the parameter values specified for the devices.  
 FEATURE         Shows the features given to these devices.

## VM Console Report

---

OPERATING SYSTEM CONFIGURATION ID: CT1VM		VM CONSOLE REPORT		TIME: 15:19	DATE: 2001-11-05	PAGE S-	1
		VM CONSOLE DEVICES					
DEVICE #	TYPE-MODEL						
0080	3270	PRIMARY SYSTEM CONSOLE					

---

Figure 53. Example of a VM Console Report

# CTC Connection Report

CTC CONNECTION REPORT															TIME: 14:28 DATE: 2003-01-14 PAGE T- 1													
LINE	SIDE 1										COMMON		SIDE 2															
	PROC.CSSID	PART. NAME	DEVICE	NUM	OS	ID	MOD	TYP	SW	PO	ID	LA	#	RNG	TYPE	UA	PROC.CSSID	PART. NAME	DEVICE	NUM	OS	ID	MOD	TYP	SW	PO	ID	LA
1	G33XMP.0	TCSS0LP2	8004	Y	20	SHR	FC	FF	06	8004	0007	22	2	FCTC	20	G33XMP.2	TCSS2LP2	8000	Y	21	SHR	FC	FF	07	8000	0006	2	
2	G33XMP.0	TCSS0LP2	8006	Y	20	SHR	FC	FF	06	8006	0007	25	2	FCTC	20	G33XMP.2	TCSS2LP5	8000	Y	21	SHR	FC	FF	07	8000	0006	2	
3	G33XMP.0	TCSS0LP2	9000	Y	20	SHR	FC	FF	06	9000	0005	4	2	FCTC	00	R31SMP	RAPOS4	9004	Y	10	SHR	FC	FF	05	9004	0006	2	
4	G33XMP.0	TCSS0LP2	9002	Y	20	SHR	FC	FF	06	9002	0005	9	2	FCTC	00	R31SMP	RAPMIX9	9004	Y	10	SHR	FC	FF	05	9004	0006	2	
5	G33XMP.0	TCSS0LP3	8004	Y	20	SHR	FC	FF	06	8004	0007	22	2	FCTC	20	G33XMP.2	TCSS2LP2	8002	Y	21	SHR	FC	FF	07	8002	0006	3	
6	G33XMP.0	TCSS0LP3	8006	Y	20	SHR	FC	FF	06	8006	0007	25	2	FCTC	20	G33XMP.2	TCSS2LP5	8002	Y	21	SHR	FC	FF	07	8002	0006	3	
7	G33XMP.0	TCSS0LP3	9000	Y	20	SHR	FC	FF	06	9000	0005	4	2	FCTC	00	R31SMP	RAPOS4	9006	Y	10	SHR	FC	FF	05	9006	0006	3	
8	G33XMP.0	TCSS0LP3	9002	Y	20	SHR	FC	FF	06	9002	0005	9	2	FCTC	00	R31SMP	RAPMIX9	9006	Y	10	SHR	FC	FF	05	9006	0006	3	
9	G33XMP.2	TCSS2LP2	8000	Y	21	SHR	FC	FF	07	8000	0006	2	2	FCTC	20	G33XMP.0	TCSS0LP2	8004	Y	20	SHR	FC	FF	06	8004	0007	22	
10	G33XMP.2	TCSS2LP2	8002	Y	21	SHR	FC	FF	07	8002	0006	3	2	FCTC	20	G33XMP.0	TCSS0LP3	8004	Y	20	SHR	FC	FF	06	8004	0007	22	
11	G33XMP.2	TCSS2LP5	8000	Y	21	SHR	FC	FF	07	8000	0006	2	2	FCTC	20	G33XMP.0	TCSS0LP2	8006	Y	20	SHR	FC	FF	06	8006	0007	25	
12	G33XMP.2	TCSS2LP5	8002	Y	21	SHR	FC	FF	07	8002	0006	3	2	FCTC	20	G33XMP.0	TCSS0LP3	8006	Y	20	SHR	FC	FF	06	8006	0007	25	
13	R31SMP	RAPMIX9	9004	Y	10	SHR	FC	FF	05	9004	0006	2	2	FCTC	00	G33XMP.0	TCSS0LP2	9002	Y	20	SHR	FC	FF	06	9002	0005	9	
14	R31SMP	RAPMIX9	9006	Y	10	SHR	FC	FF	05	9006	0006	3	2	FCTC	00	G33XMP.0	TCSS0LP3	9002	Y	20	SHR	FC	FF	06	9002	0005	9	
15	R31SMP	RAPOS4	9004	Y	10	SHR	FC	FF	05	9004	0006	2	2	FCTC	00	G33XMP.0	TCSS0LP2	9000	Y	20	SHR	FC	FF	06	9000	0005	4	
16	R31SMP	RAPOS4	9006	Y	10	SHR	FC	FF	05	9006	0006	3	2	FCTC	00	G33XMP.0	TCSS0LP3	9000	Y	20	SHR	FC	FF	06	9000	0005	4	

CTC CONNECTION REPORT															TIME: 14:28 DATE: 2003-01-14 PAGE T- 2		
KEY	KEY DESCRIPTION																
---	-----																
LINE NR	- LINE NUMBER USED TO REFER TO CTC MESSAGES - A MESSAGE IS INDICATED BY AN ASTERIX (*)																
SIDE 1 / SIDE 2																	
PROC.CSSID	- PROCESSOR ID RESPECTIVELY CHANNEL SUBSYSTEM ID																
PARTITION NAME	- PARTITION NAME																
DEVICE NUM	- DEVICE NUMBER																
DEVICE OS	- INDICATION, IF FIRST DEVICE OF RANGE IS DEFINED TO AN OPERATING SYSTEM																
CHPID ID	- CHANNEL PATH ID IN CHANNEL SUBSYSTEM																
CHPID MOD	- CHANNEL PATH MODE																
CHPID TYPE	- CHANNEL PATH TYPE																
ENTRY SW	- ENTRY SWITCH OF THE CHANNEL PATH																
ENTRY PO	- ENTRY PORT OF THE CHANNEL PATH																
CU ID	- CONTROL UNIT NUMBER																
CU LA	- LINK ADDRESS OF CONTROL UNIT RELATED TO THE CHANNEL PATH																
CU #	- LOGICAL ADDRESS (CUADD) RELATED TO THE PROCESSOR																
COMMON																	
DEVICE RNG	- DEVICE RANGE FOR DEVICES ON SIDE 1 AND SIDE 2																
DEVICE TYPE	- DEVICE TYPE COMMON TO DEVICES ON SIDE 1 AND SIDE 2 (IF MESSAGE G751 THEN DEVICE TYPE OF SIDE 1)																
DEVICE UA	- UNIT ADDRESS OF DEVICES RELATED TO THE PROCESSOR (COMMON TO SIDE 1 AND SIDE 2)																

Figure 54. Example of a CTC Connection Report

## Diagnostic Messages

The following example shows you messages that might be returned with the report. The diagnostic messages are sorted by severity. For each connection, HCD displays only one message, even if the connection includes several errors. You first have to correct the first error before the next message is displayed. HCD displays the messages according to a certain priority.

---

		CTC CONNECTION REPORT	TIME: 17:42 DATE: 1997-08-03 PAGE U- 3	
LINE	SEV	MSGID	MESSAGE TEXT	
1	E	CBDG750I	Logical address (CUADD) is specified for CU 1010, but CHPID 20 of processor PROC001A is not defined as shared.	
3	E	CBDG750I	Logical address (CUADD) is specified for CU 1010, but CHPID 20 of processor PROC001A is not defined as shared.	
4	E	CBDG752I	Channel path type error. CHPID 20 of processor PROC001A is connected to a CHPID 11 of processor PROC002 with the same type.	
8	E	CBDG752I	Channel path type error. CHPID 11 of processor PROC002 is connected to a CHPID 20 of processor PROC001A with the same type.	
11	E	CBDG751I	Device type of device 0805 connected to processor PROC002, CHPID 22 does not match with device type of device 0405 on the other side.	
13	E	CBDG750I	Logical address (CUADD) is specified for CU 0108, but CHPID 21 of processor PROC003 is not defined as shared.	
18	E	CBDG750I	Logical address (CUADD) is specified for CU 0108, but CHPID 21 of processor PROC003 is not defined as shared.	
21	E	CBDG751I	Device type of device 0405 connected to processor PROC003, CHPID 11 does not match with device type of device 0805 on the other side.	
6	W	CBDG753I	Wrap around connection detected for processor PROC002 (partition - none -) via CHPID 11 and CHPID 13.	
7	W	CBDG753I	Wrap around connection detected for processor PROC002 (partition - none -) via CHPID 13 and CHPID 11.	
15	W	CBDG754I	HCD cannot determine connection. No control units and devices match to processor PROC003, partition PART1, CU 1012 and device 1012.	
19	W	CBDG754I	HCD cannot determine connection. No control units and devices match to processor PROC003, partition PART2, CU 1012 and device 1012.	
5	I	CBDG757I	HCD cannot determine connection. CHPID 10 of processor PROC002 has no dynamic switch defined.	
14	I	CBDG756I	HCD cannot determine connection. CHPID 24 of processor PROC002 is connected via chained switches.	
Total Messages	Terminating	Error	Warning	Informational
14		8	4	2

---

Figure 55. Sample of Diagnostic Messages coming with the CTC connection report

## Supported Hardware Report

The Supported Hardware Report shows the actual status of the hardware supported in your installation. It shows the following supported hardware:

- Processors
- Control units
- Devices including:
  - Device characteristics
  - Control unit attachments
- MVS devices including:
  - Device capabilities
  - Parameters (with selection values) / features
- VM devices including
  - device capabilities
  - parameters/features

The following figure shows you an example of a supported hardware report. The example may differ from the report you get on your system, because the data depend on the installed processor support modules and UIMs.

SUPPORTED HARDWARE - PROCESSORS										TIME: 11:16 DATE: 2015-11-24 PAGE X- 1						
TYPE-MODEL	MOD	SUPLEVID	IOCP	SYSTEM	SUPPORTED CHPID TYPES	WI	RI	DP	FCT	CHPID	CU	LCU	SUBCH	LPAR	CSS	SCHS
2064-1C1	200	H000931	IYP	2064,1	BL,BY,CNC,CTC,CVC,CFR,CFS,CBY,OSA,FC,FCV,CBR,CBS,OSD,OSE,CFP,CBP,ICP,IQD,FCP	Y	Y	N	NN	256	8192	4096	64512	15		
2064-1C1	202	H010931	IYP	2064,1	BL,BY,CNC,CTC,CVC,CFR,CFS,CBY,OSA,FC,FCV,CBR,CBS,OSD,OSE,CFP,CBP,ICP,IQD,FCP	Y	Y	N	NN	256	8192	4096	64512	15		
2064-1C2	200	H000931	IYP	2064,1	BL,BY,CNC,CTC,CVC,CFR,CFS,CBY,OSA,FC,FCV,CBR,CBS,OSD,OSE,CFP,CBP,ICP,IQD,FCP	Y	Y	N	NN	256	8192	4096	64512	15		
2064-1C2	202	H010931	IYP	2064,1	BL,BY,CNC,CTC,CVC,CFR,CFS,CBY,OSA,FC,FCV,CBR,CBS,OSD,OSE,CFP,CBP,ICP,IQD,FCP	Y	Y	N	NN	256	8192	4096	64512	15		
2064-1C3	200	H000931	IYP	2064,1	BL,BY,CNC,CTC,CVC,CFR,CFS,CBY,OSA,FC,FCV,CBR,CBS,OSD,OSE,CFP,CBP,ICP,IQD,FCP	Y	Y	N	NN	256	8192	4096	64512	15		
2064-1C3	202	H010931	IYP	2064,1	BL,BY,CNC,CTC,CVC,CFR,CFS,CBY,OSA,FC,FCV,CBR,CBS,OSD,OSE,CFP,CBP,ICP,IQD,FCP	Y	Y	N	NN	256	8192	4096	64512	15		
2064-1C4	200	H000931	IYP	2064,1	BL,BY,CNC,CTC,CVC,CFR,CFS,CBY,OSA,FC,FCV,CBR,CBS,OSD,OSE,CFP,CBP,ICP,IQD,FCP	Y	Y	N	NN	256	8192	4096	64512	15		
2064-1C4	202	H010931	IYP	2064,1	BL,BY,CNC,CTC,CVC,CFR,CFS,CBY,OSA,FC,FCV,CBR,CBS,OSD,OSE,CFP,CBP,ICP,IQD,FCP	Y	Y	N	NN	256	8192	4096	64512	15		
2064-1C5	200	H000931	IYP	2064,1	BL,BY,CNC,CTC,CVC,CFR,CFS,CBY,OSA,FC,FCV,CBR,CBS,OSD,OSE,CFP,CBP,ICP,IQD,FCP	Y	Y	N	NN	256	8192	4096	64512	15		
2064-1C5	202	H010931	IYP	2064,1	BL,BY,CNC,CTC,CVC,CFR,CFS,CBY,OSA,FC,FCV,CBR,CBS,OSD,OSE,CFP,CBP,ICP,IQD,FCP	Y	Y	N	NN	256	8192	4096	64512	15		
2064-1C6	200	H000931	IYP	2064,1	BL,BY,CNC,CTC,CVC,CFR,CFS,CBY,OSA,FC,FCV,CBR,CBS,OSD,OSE,CFP,CBP,ICP,IQD,FCP	Y	Y	N	NN	256	8192	4096	64512	15		
2064-1C6	202	H010931	IYP	2064,1	BL,BY,CNC,CTC,CVC,CFR,CFS,CBY,OSA,FC,FCV,CBR,CBS,OSD,OSE,CFP,CBP,ICP,IQD,FCP	Y	Y	N	NN	256	8192	4096	64512	15		
2064-1C7	200	H000931	IYP	2064,1	BL,BY,CNC,CTC,CVC,CFR,CFS,CBY,OSA,FC,FCV,CBR,CBS,OSD,OSE,CFP,CBP,ICP,IQD,FCP	Y	Y	N	NN	256	8192	4096	64512	15		
2064-1C7	202	H010931	IYP	2064,1	BL,BY,CNC,CTC,CVC,CFR,CFS,CBY,OSA,FC,FCV,CBR,CBS,OSD,OSE,CFP,CBP,ICP,IQD,FCP	Y	Y	N	NN	256	8192	4096	64512	15		
2064-1C8	200	H000931	IYP	2064,1	BL,BY,CNC,CTC,CVC,CFR,CFS,CBY,OSA,FC,FCV,CBR,CBS,OSD,OSE,CFP,CBP,ICP,IQD,FCP	Y	Y	N	NN	256	8192	4096	64512	15		
2064-1C8	202	H010931	IYP	2064,1	BL,BY,CNC,CTC,CVC,CFR,CFS,CBY,OSA,FC,FCV,CBR,CBS,OSD,OSE,CFP,CBP,ICP,IQD,FCP	Y	Y	N	NN	256	8192	4096	64512	15		
2064-1C9	200	H000931	IYP	2064,1	BL,BY,CNC,CTC,CVC,CFR,CFS,CBY,OSA,FC,FCV,CBR,CBS,OSD,OSE,CFP,CBP,ICP,IQD,FCP	Y	Y	N	NN	256	8192	4096	64512	15		
2064-1C9	202	H010931	IYP	2064,1	BL,BY,CNC,CTC,CVC,CFR,CFS,CBY,OSA,FC,FCV,CBR,CBS,OSD,OSE,CFP,CBP,ICP,IQD,FCP	Y	Y	N	NN	256	8192	4096	64512	15		
2064-100	201	H000931	IYP	2064,2	CFR,CFS,CBR,CBS,CFP,CBP,ICP	Y	Y	N	NN	64	8192	4096	64512	15		
2064-101	200	H000931	IYP	2064,1	BL,BY,CNC,CTC,CVC,CFR,CFS,CBY,OSA,FC,FCV,CBR,CBS,OSD,OSE,CFP,CBP,ICP,IQD,FCP	Y	Y	N	NN	256	8192	4096	64512	15		
2064-101	202	H010931	IYP	2064,1	BL,BY,CNC,CTC,CVC,CFR,CFS,CBY,OSA,FC,FCV,CBR,CBS,OSD,OSE,CFP,CBP,ICP,IQD,FCP	Y	Y	N	NN	256	8192	4096	64512	15		
2064-102	200	H000931	IYP	2064,1	BL,BY,CNC,CTC,CVC,CFR,CFS,CBY,OSA,FC,FCV,CBR,CBS,OSD,OSE,CFP,CBP,ICP,IQD,FCP	Y	Y	N	NN	256	8192	4096	64512	15		
2064-102	202	H010931	IYP	2064,1	BL,BY,CNC,CTC,CVC,CFR,CFS,CBY,OSA,FC,FCV,CBR,CBS,OSD,OSE,CFP,CBP,ICP,IQD,FCP	Y	Y	N	NN	256	8192	4096	64512	15		
2064-103	200	H000931	IYP	2064,1	BL,BY,CNC,CTC,CVC,CFR,CFS,CBY,OSA,FC,FCV,CBR,CBS,OSD,OSE,CFP,CBP,ICP,IQD,FCP	Y	Y	N	NN	256	8192	4096	64512	15		
2064-103	202	H010931	IYP	2064,1	BL,BY,CNC,CTC,CVC,CFR,CFS,CBY,OSA,FC,FCV,CBR,CBS,OSD,OSE,CFP,CBP,ICP,IQD,FCP	Y	Y	N	NN	256	8192	4096	64512	15		

Figure 56. Supported Hardware Report - Processors (Part 1 of 26)

					SUPPORTED HARDWARE - PROCESSORS				TIME: 11:16 DATE: 2015-11-24 PAGE X- 2									
TYPE-MODEL	MOD	SUPLEVID	IOCP	SYSTEM	SUPPORTED	CHPID	TYPES	WI	RI	DP	FCT	CHPID	CU	LCU	SUBCH	LPAR	CSS	SCHS
2064-104	200	H000931	IYP	2064,1	ICP, IQD, FCP			Y	Y	N	NN	256	8192	4096	64512	15		
					BL, BY, CNC, CTC, CVC, CFR, CFS, CBY, OSA, FC, FCV, CBR, CBS, OSD, OSE, CFP, CBP, ICP, IQD, FCP													
2064-104	202	H010931	IYP	2064,1	BL, BY, CNC, CTC, CVC, CFR, CFS, CBY, OSA, FC, FCV, CBR, CBS, OSD, OSE, CFP, CBP, ICP, IQD, FCP			Y	Y	N	NN	256	8192	4096	64512	15		
2064-105	200	H000931	IYP	2064,1	BL, BY, CNC, CTC, CVC, CFR, CFS, CBY, OSA, FC, FCV, CBR, CBS, OSD, OSE, CFP, CBP, ICP, IQD, FCP			Y	Y	N	NN	256	8192	4096	64512	15		
2064-105	202	H010931	IYP	2064,1	BL, BY, CNC, CTC, CVC, CFR, CFS, CBY, OSA, FC, FCV, CBR, CBS, OSD, OSE, CFP, CBP, ICP, IQD, FCP			Y	Y	N	NN	256	8192	4096	64512	15		
2064-106	200	H000931	IYP	2064,1	BL, BY, CNC, CTC, CVC, CFR, CFS, CBY, OSA, FC, FCV, CBR, CBS, OSD, OSE, CFP, CBP, ICP, IQD, FCP			Y	Y	N	NN	256	8192	4096	64512	15		
2064-106	202	H010931	IYP	2064,1	BL, BY, CNC, CTC, CVC, CFR, CFS, CBY, OSA, FC, FCV, CBR, CBS, OSD, OSE, CFP, CBP, ICP, IQD, FCP			Y	Y	N	NN	256	8192	4096	64512	15		
2064-107	200	H000931	IYP	2064,1	BL, BY, CNC, CTC, CVC, CFR, CFS, CBY, OSA, FC, FCV, CBR, CBS, OSD, OSE, CFP, CBP, ICP, IQD, FCP			Y	Y	N	NN	256	8192	4096	64512	15		
2064-107	202	H010931	IYP	2064,1	BL, BY, CNC, CTC, CVC, CFR, CFS, CBY, OSA, FC, FCV, CBR, CBS, OSD, OSE, CFP, CBP, ICP, IQD, FCP			Y	Y	N	NN	256	8192	4096	64512	15		
2064-108	200	H000931	IYP	2064,1	BL, BY, CNC, CTC, CVC, CFR, CFS, CBY, OSA, FC, FCV, CBR, CBS, OSD, OSE, CFP, CBP, ICP, IQD, FCP			Y	Y	N	NN	256	8192	4096	64512	15		
2064-108	202	H010931	IYP	2064,1	BL, BY, CNC, CTC, CVC, CFR, CFS, CBY, OSA, FC, FCV, CBR, CBS, OSD, OSE, CFP, CBP, ICP, IQD, FCP			Y	Y	N	NN	256	8192	4096	64512	15		
2064-109	200	H000931	IYP	2064,1	BL, BY, CNC, CTC, CVC, CFR, CFS, CBY, OSA, FC, FCV, CBR, CBS, OSD, OSE, CFP, CBP, ICP, IQD, FCP			Y	Y	N	NN	256	8192	4096	64512	15		
2064-109	202	H010931	IYP	2064,1	BL, BY, CNC, CTC, CVC, CFR, CFS, CBY, OSA, FC, FCV, CBR, CBS, OSD, OSE, CFP, CBP, ICP, IQD, FCP			Y	Y	N	NN	256	8192	4096	64512	15		
2064-110	200	H000931	IYP	2064,1	BL, BY, CNC, CTC, CVC, CFR, CFS, CBY, OSA, FC, FCV, CBR, CBS, OSD, OSE, CFP, CBP, ICP, IQD, FCP			Y	Y	N	NN	256	8192	4096	64512	15		
2064-110	202	H010931	IYP	2064,1	BL, BY, CNC, CTC, CVC, CFR, CFS, CBY, OSA, FC, FCV, CBR, CBS, OSD, OSE, CFP, CBP, ICP, IQD, FCP			Y	Y	N	NN	256	8192	4096	64512	15		
2064-111	200	H000931	IYP	2064,1	BL, BY, CNC, CTC, CVC, CFR, CFS, CBY, OSA, FC, FCV, CBR, CBS, OSD, OSE, CFP, CBP, ICP, IQD, FCP			Y	Y	N	NN	256	8192	4096	64512	15		
2064-111	202	H010931	IYP	2064,1	BL, BY, CNC, CTC, CVC, CFR, CFS, CBY, OSA, FC, FCV, CBR, CBS, OSD, OSE, CFP, CBP, ICP, IQD, FCP			Y	Y	N	NN	256	8192	4096	64512	15		
2064-112	200	H000931	IYP	2064,1	BL, BY, CNC, CTC, CVC, CFR, CFS, CBY, OSA, FC, FCV, CBR, CBS, OSD, OSE, CFP, CBP, ICP, IQD, FCP			Y	Y	N	NN	256	8192	4096	64512	15		
2064-112	202	H010931	IYP	2064,1	BL, BY, CNC, CTC, CVC, CFR, CFS, CBY, OSA, FC, FCV, CBR, CBS, OSD, OSE, CFP, CBP, ICP, IQD, FCP			Y	Y	N	NN	256	8192	4096	64512	15		
2064-113	200	H000931	IYP	2064,1	BL, BY, CNC, CTC, CVC, CFR, CFS, CBY, OSA, FC, FCV, CBR, CBS, OSD, OSE, CFP, CBP, ICP, IQD, FCP			Y	Y	N	NN	256	8192	4096	64512	15		
2064-113	202	H010931	IYP	2064,1	BL, BY, CNC, CTC, CVC, CFR, CFS, CBY, OSA, FC, FCV, CBR, CBS, OSD, OSE, CFP, CBP, ICP, IQD, FCP			Y	Y	N	NN	256	8192	4096	64512	15		
2064-114	200	H000931	IYP	2064,1	BL, BY, CNC, CTC, CVC, CFR, CFS, CBY, OSA, FC, FCV, CBR, CBS, OSD, OSE, CFP, CBP, ICP, IQD, FCP			Y	Y	N	NN	256	8192	4096	64512	15		
2064-114	202	H010931	IYP	2064,1	BL, BY, CNC, CTC, CVC, CFR, CFS, CBY, OSA, FC, FCV, CBR, CBS, OSD, OSE, CFP, CBP, ICP, IQD, FCP			Y	Y	N	NN	256	8192	4096	64512	15		
2064-115	200	H000931	IYP	2064,1	BL, BY, CNC, CTC, CVC, CFR, CFS, CBY, OSA, FC, FCV, CBR, CBS, OSD, OSE, CFP, CBP, ICP, IQD, FCP			Y	Y	N	NN	256	8192	4096	64512	15		
2064-115	202	H010931	IYP	2064,1	BL, BY, CNC, CTC, CVC, CFR, CFS, CBY, OSA, FC, FCV, CBR, CBS, OSD, OSE, CFP, CBP, ICP, IQD, FCP			Y	Y	N	NN	256	8192	4096	64512	15		

Figure 57. Supported Hardware Report - Processors (Part 2 of 26)

					SUPPORTED HARDWARE - PROCESSORS		TIME: 11:16 DATE: 2015-11-24 PAGE X- 3											
TYPE-MODEL	MOD	SUPLEVID	IOCP	SYSTEM	SUPPORTED	CHPID	TYPES	WI	RI	DP	FCT	CHPID	CU	LCU	SUBCH	LPAR	CSS	SCHS
2064-116	200	H000931	IYP	2064,1	ICP, IQD, FCP			Y	Y	N	NN	256	8192	4096	64512	15		
2064-116	202	H010931	IYP	2064,1	BL, BY, CNC, CTC, CVC, CFR, CFS, CBY, OSA, FC, FCV, CBR, CBS, OSD, OSE, CFP, CBP, ICP, IQD, FCP			Y	Y	N	NN	256	8192	4096	64512	15		
2064-2C1	200	H000931	IYP	2064,1	BL, BY, CNC, CTC, CVC, CFR, CFS, CBY, OSA, FC, FCV, CBR, CBS, OSD, OSE, CFP, CBP, ICP, IQD, FCP			Y	Y	N	NN	256	8192	4096	64512	15		
2064-2C1	202	H020415	IYP	2064,1	BL, BY, CNC, CTC, CVC, CFR, CFS, CBY, OSA, FC, FCV, CBR, CBS, OSD, OSE, CFP, CBP, ICP, IQD, FCP			Y	Y	N	NN	256	8192	4096	64512	15		
2064-2C2	200	H000931	IYP	2064,1	BL, BY, CNC, CTC, CVC, CFR, CFS, CBY, OSA, FC, FCV, CBR, CBS, OSD, OSE, CFP, CBP, ICP, IQD, FCP			Y	Y	N	NN	256	8192	4096	64512	15		
2064-2C2	202	H020415	IYP	2064,1	BL, BY, CNC, CTC, CVC, CFR, CFS, CBY, OSA, FC, FCV, CBR, CBS, OSD, OSE, CFP, CBP, ICP, IQD, FCP			Y	Y	N	NN	256	8192	4096	64512	15		
2064-2C3	200	H000931	IYP	2064,1	BL, BY, CNC, CTC, CVC, CFR, CFS, CBY, OSA, FC, FCV, CBR, CBS, OSD, OSE, CFP, CBP, ICP, IQD, FCP			Y	Y	N	NN	256	8192	4096	64512	15		
2064-2C3	202	H020415	IYP	2064,1	BL, BY, CNC, CTC, CVC, CFR, CFS, CBY, OSA, FC, FCV, CBR, CBS, OSD, OSE, CFP, CBP, ICP, IQD, FCP			Y	Y	N	NN	256	8192	4096	64512	15		
2064-2C4	200	H000931	IYP	2064,1	BL, BY, CNC, CTC, CVC, CFR, CFS, CBY, OSA, FC, FCV, CBR, CBS, OSD, OSE, CFP, CBP, ICP, IQD, FCP			Y	Y	N	NN	256	8192	4096	64512	15		
2064-2C4	202	H020415	IYP	2064,1	BL, BY, CNC, CTC, CVC, CFR, CFS, CBY, OSA, FC, FCV, CBR, CBS, OSD, OSE, CFP, CBP, ICP, IQD, FCP			Y	Y	N	NN	256	8192	4096	64512	15		
2064-2C5	200	H000931	IYP	2064,1	BL, BY, CNC, CTC, CVC, CFR, CFS, CBY, OSA, FC, FCV, CBR, CBS, OSD, OSE, CFP, CBP, ICP, IQD, FCP			Y	Y	N	NN	256	8192	4096	64512	15		
2064-2C5	202	H020415	IYP	2064,1	BL, BY, CNC, CTC, CVC, CFR, CFS, CBY, OSA, FC, FCV, CBR, CBS, OSD, OSE, CFP, CBP, ICP, IQD, FCP			Y	Y	N	NN	256	8192	4096	64512	15		
2064-2C6	200	H000931	IYP	2064,1	BL, BY, CNC, CTC, CVC, CFR, CFS, CBY, OSA, FC, FCV, CBR, CBS, OSD, OSE, CFP, CBP, ICP, IQD, FCP			Y	Y	N	NN	256	8192	4096	64512	15		
2064-2C6	202	H020415	IYP	2064,1	BL, BY, CNC, CTC, CVC, CFR, CFS, CBY, OSA, FC, FCV, CBR, CBS, OSD, OSE, CFP, CBP, ICP, IQD, FCP			Y	Y	N	NN	256	8192	4096	64512	15		
2064-2C7	200	H000931	IYP	2064,1	BL, BY, CNC, CTC, CVC, CFR, CFS, CBY, OSA, FC, FCV, CBR, CBS, OSD, OSE, CFP, CBP, ICP, IQD, FCP			Y	Y	N	NN	256	8192	4096	64512	15		
2064-2C7	202	H020415	IYP	2064,1	BL, BY, CNC, CTC, CVC, CFR, CFS, CBY, OSA, FC, FCV, CBR, CBS, OSD, OSE, CFP, CBP, ICP, IQD, FCP			Y	Y	N	NN	256	8192	4096	64512	15		
2064-2C8	200	H000931	IYP	2064,1	BL, BY, CNC, CTC, CVC, CFR, CFS, CBY, OSA, FC, FCV, CBR, CBS, OSD, OSE, CFP, CBP, ICP, IQD, FCP			Y	Y	N	NN	256	8192	4096	64512	15		
2064-2C8	202	H020415	IYP	2064,1	BL, BY, CNC, CTC, CVC, CFR, CFS, CBY, OSA, FC, FCV, CBR, CBS, OSD, OSE, CFP, CBP, ICP, IQD, FCP			Y	Y	N	NN	256	8192	4096	64512	15		
2064-2C9	200	H000931	IYP	2064,1	BL, BY, CNC, CTC, CVC, CFR, CFS, CBY, OSA, FC, FCV, CBR, CBS, OSD, OSE, CFP, CBP, ICP, IQD, FCP			Y	Y	N	NN	256	8192	4096	64512	15		
2064-2C9	202	H020415	IYP	2064,1	BL, BY, CNC, CTC, CVC, CFR, CFS, CBY, OSA, FC, FCV, CBR, CBS, OSD, OSE, CFP, CBP, ICP, IQD, FCP			Y	Y	N	NN	256	8192	4096	64512	15		
2064-210	200	H000931	IYP	2064,1	BL, BY, CNC, CTC, CVC, CFR, CFS, CBY, OSA, FC, FCV, CBR, CBS, OSD, OSE, CFP, CBP, ICP, IQD, FCP			Y	Y	N	NN	256	8192	4096	64512	15		
2064-210	202	H020415	IYP	2064,1	BL, BY, CNC, CTC, CVC, CFR, CFS, CBY, OSA, FC, FCV, CBR, CBS, OSD, OSE, CFP, CBP, ICP, IQD, FCP			Y	Y	N	NN	256	8192	4096	64512	15		
2064-211	200	H000931	IYP	2064,1	BL, BY, CNC, CTC, CVC, CFR, CFS, CBY, OSA, FC, FCV, CBR, CBS, OSD, OSE, CFP, CBP, ICP, IQD, FCP			Y	Y	N	NN	256	8192	4096	64512	15		
2064-211	202	H020415	IYP	2064,1	BL, BY, CNC, CTC, CVC, CFR, CFS, CBY, OSA, FC, FCV, CBR, CBS, OSD, OSE, CFP, CBP, ICP, IQD, FCP			Y	Y	N	NN	256	8192	4096	64512	15		

Figure 58. Supported Hardware Report - Processors (Part 3 of 26)

					SUPPORTED HARDWARE - PROCESSORS				TIME: 11:16 DATE: 2015-11-24 PAGE X- 4							
TYPE-MODEL	MOD	SUPLEVID	IOCP	SYSTEM	SUPPORTED CHPID TYPES	WI	RI	DP	FCT	CHPID	CU	LCU	SUBCH	LPAR	CSS	SCHS
2064-212	200	H000931	IYP	2064,1	ICP, IQD, FCP BL, BY, CNC, CTC, CVC, CFR, CFS, CBY, OSA, FC, FCV, CBR, CBS, OSD, OSE, CFP, CBP, ICP, IQD, FCP	Y	Y	N	NN	256	8192	4096	64512	15		
2064-212	202	H020415	IYP	2064,1	BL, BY, CNC, CTC, CVC, CFR, CFS, CBY, OSA, FC, FCV, CBR, CBS, OSD, OSE, CFP, CBP, ICP, IQD, FCP	Y	Y	N	NN	256	8192	4096	64512	15		
2064-213	200	H000931	IYP	2064,1	BL, BY, CNC, CTC, CVC, CFR, CFS, CBY, OSA, FC, FCV, CBR, CBS, OSD, OSE, CFP, CBP, ICP, IQD, FCP	Y	Y	N	NN	256	8192	4096	64512	15		
2064-213	202	H020415	IYP	2064,1	BL, BY, CNC, CTC, CVC, CFR, CFS, CBY, OSA, FC, FCV, CBR, CBS, OSD, OSE, CFP, CBP, ICP, IQD, FCP	Y	Y	N	NN	256	8192	4096	64512	15		
2064-214	200	H000931	IYP	2064,1	BL, BY, CNC, CTC, CVC, CFR, CFS, CBY, OSA, FC, FCV, CBR, CBS, OSD, OSE, CFP, CBP, ICP, IQD, FCP	Y	Y	N	NN	256	8192	4096	64512	15		
2064-214	202	H020415	IYP	2064,1	BL, BY, CNC, CTC, CVC, CFR, CFS, CBY, OSA, FC, FCV, CBR, CBS, OSD, OSE, CFP, CBP, ICP, IQD, FCP	Y	Y	N	NN	256	8192	4096	64512	15		
2064-215	200	H000931	IYP	2064,1	BL, BY, CNC, CTC, CVC, CFR, CFS, CBY, OSA, FC, FCV, CBR, CBS, OSD, OSE, CFP, CBP, ICP, IQD, FCP	Y	Y	N	NN	256	8192	4096	64512	15		
2064-215	202	H020415	IYP	2064,1	BL, BY, CNC, CTC, CVC, CFR, CFS, CBY, OSA, FC, FCV, CBR, CBS, OSD, OSE, CFP, CBP, ICP, IQD, FCP	Y	Y	N	NN	256	8192	4096	64512	15		
2064-216	200	H000931	IYP	2064,1	BL, BY, CNC, CTC, CVC, CFR, CFS, CBY, OSA, FC, FCV, CBR, CBS, OSD, OSE, CFP, CBP, ICP, IQD, FCP	Y	Y	N	NN	256	8192	4096	64512	15		
2064-216	202	H020415	IYP	2064,1	BL, BY, CNC, CTC, CVC, CFR, CFS, CBY, OSA, FC, FCV, CBR, CBS, OSD, OSE, CFP, CBP, ICP, IQD, FCP	Y	Y	N	NN	256	8192	4096	64512	15		
2066-0A1	206	H020331	IYP	2066,1	CNC, CTC, CVC, CFR, CFS, CBY, FC, FCV, OSD, OSE, CFP, CBP, ICP, IQD, FCP	Y	Y	N	NN	256	8192	4096	64512	15		
2066-0A1	208	H020731	IYP	2066,1	CNC, CTC, CVC, CFR, CFS, CBY, FC, FCV, OSD, OSE, CFP, CBP, ICP, IQD, FCP	Y	Y	N	NN	256	8192	4096	64512	15		
2066-0A2	206	H020331	IYP	2066,1	CNC, CTC, CVC, CFR, CFS, CBY, FC, FCV, OSD, OSE, CFP, CBP, ICP, IQD, FCP	Y	Y	N	NN	256	8192	4096	64512	15		
2066-0A2	208	H020731	IYP	2066,1	CNC, CTC, CVC, CFR, CFS, CBY, FC, FCV, OSD, OSE, CFP, CBP, ICP, IQD, FCP	Y	Y	N	NN	256	8192	4096	64512	15		
2066-0B1	206	H020331	IYP	2066,1	CNC, CTC, CVC, CFR, CFS, CBY, FC, FCV, OSD, OSE, CFP, CBP, ICP, IQD, FCP	Y	Y	N	NN	256	8192	4096	64512	15		
2066-0B1	208	H020731	IYP	2066,1	CNC, CTC, CVC, CFR, CFS, CBY, FC, FCV, OSD, OSE, CFP, CBP, ICP, IQD, FCP	Y	Y	N	NN	256	8192	4096	64512	15		
2066-0CF	207	H020331	IYP	2066,2	CFR, CFS, CFP, CBP, ICP	Y	Y	N	NN	64	8192	4096	64512	15		
2066-0C1	206	H020331	IYP	2066,1	CNC, CTC, CVC, CFR, CFS, CBY, FC, FCV, OSD, OSE, CFP, CBP, ICP, IQD, FCP	Y	Y	N	NN	256	8192	4096	64512	15		
2066-0C1	208	H020731	IYP	2066,1	CNC, CTC, CVC, CFR, CFS, CBY, FC, FCV, OSD, OSE, CFP, CBP, ICP, IQD, FCP	Y	Y	N	NN	256	8192	4096	64512	15		
2066-0E1	206	H020331	IYP	2066,1	CNC, CTC, CVC, CFR, CFS, CBY, FC, FCV, OSD, OSE, CFP, CBP, ICP, IQD, FCP	Y	Y	N	NN	256	8192	4096	64512	15		
2066-0E1	208	H020731	IYP	2066,1	CNC, CTC, CVC, CFR, CFS, CBY, FC, FCV, OSD, OSE, CFP, CBP, ICP, IQD, FCP	Y	Y	N	NN	256	8192	4096	64512	15		
2066-0LF	206	H020331	IYP	2066,1	CNC, CTC, CVC, CFR, CFS, CBY, FC, FCV, OSD, OSE, CFP, CBP, ICP, IQD, FCP	Y	Y	N	NN	256	8192	4096	64512	15		
2066-0LF	208	H020731	IYP	2066,1	CNC, CTC, CVC, CFR, CFS, CBY, FC, FCV, OSD, OSE, CFP, CBP, ICP, IQD, FCP	Y	Y	N	NN	256	8192	4096	64512	15		
2066-0X2	206	H020331	IYP	2066,1	CNC, CTC, CVC, CFR, CFS, CBY, FC, FCV, OSD, OSE, CFP, CBP, ICP, IQD, FCP	Y	Y	N	NN	256	8192	4096	64512	15		
2066-0X2	208	H020731	IYP	2066,1	CNC, CTC, CVC, CFR, CFS, CBY, FC, FCV, OSD, OSE, CFP, CBP, ICP, IQD, FCP	Y	Y	N	NN	256	8192	4096	64512	15		
2066-001	206	H020331	IYP	2066,1	CNC, CTC, CVC, CFR, CFS, CBY, FC, FCV, OSD, OSE, CFP, CBP, ICP, IQD, FCP	Y	Y	N	NN	256	8192	4096	64512	15		
2066-001	208	H020731	IYP	2066,1	CNC, CTC, CVC, CFR, CFS, CBY, FC, FCV, OSD, OSE, CFP, CBP, ICP, IQD, FCP	Y	Y	N	NN	256	8192	4096	64512	15		
2066-002	206	H020331	IYP	2066,1	CNC, CTC, CVC, CFR, CFS, CBY, FC, FCV, OSD, OSE, CFP, CBP, ICP, IQD, FCP	Y	Y	N	NN	256	8192	4096	64512	15		
2066-002	208	H020731	IYP	2066,1	CNC, CTC, CVC, CFR, CFS, CBY, FC, FCV, OSD, OSE, CFP, CBP, ICP, IQD, FCP	Y	Y	N	NN	256	8192	4096	64512	15		
2066-003	206	H020331	IYP	2066,1	CNC, CTC, CVC, CFR, CFS, CBY, FC, FCV, OSD, OSE, CFP, CBP, ICP, IQD, FCP	Y	Y	N	NN	256	8192	4096	64512	15		
2066-003	208	H020731	IYP	2066,1	CNC, CTC, CVC, CFR, CFS, CBY, FC, FCV, OSD, OSE, CFP, CBP, ICP, IQD, FCP	Y	Y	N	NN	256	8192	4096	64512	15		

Figure 59. Supported Hardware Report - Processors (Part 4 of 26)

				SUPPORTED HARDWARE - PROCESSORS		TIME: 11:16 DATE: 2015-11-24 PAGE X- 5										
TYPE-MODEL	MOD	SUPLEVID	IOCP	SYSTEM	SUPPORTED CHPID TYPES	WI	RI	DP	FCT	CHPID	CU	LCU	SUBCH	LPAR	CSS	SCHS
2066-004	206	H020331	IYP	2066,1	CNC,CTC,CVC,CFR,CFS,CBY,FC,FCV,OSD,OSE,CFP,CBP,ICP,IQD,FCP	Y	Y	N	NN	256	8192	4096	64512	15		
2066-004	208	H020731	IYP	2066,1	CNC,CTC,CVC,CFR,CFS,CBY,FC,FCV,OSD,OSE,CFP,CBP,ICP,IQD,FCP	Y	Y	N	NN	256	8192	4096	64512	15		
2084-A08	210	H030530	ICP	2084,1	CNC,CTC,CVC,CFR,CFS,CBY,FC,FCV,CBR,CBS,OSD,OSE,CFP,CBP,ICP,IQD,FCP	Y	Y	N	NN	512	8192	4096	64512	30	2	
2084-A08	211	H040331	ICP	2084,1	CNC,CTC,CVC,CFR,CFS,CBY,FC,FCV,CBR,CBS,OSD,OSE,CFP,CBP,ICP,IQD,FCP,OSC	Y	Y	Y	NN	1024	8192	4096	64512	30	4	
2084-B16	210	H030530	ICP	2084,1	CNC,CTC,CVC,CFR,CFS,CBY,FC,FCV,CBR,CBS,OSD,OSE,CFP,CBP,ICP,IQD,FCP	Y	Y	N	NN	512	8192	4096	64512	30	2	
2084-B16	211	H040331	ICP	2084,1	CNC,CTC,CVC,CFR,CFS,CBY,FC,FCV,CBR,CBS,OSD,OSE,CFP,CBP,ICP,IQD,FCP,OSC	Y	Y	Y	NN	1024	8192	4096	64512	30	4	
2084-C24	210	H030530	ICP	2084,1	CNC,CTC,CVC,CFR,CFS,CBY,FC,FCV,CBR,CBS,OSD,OSE,CFP,CBP,ICP,IQD,FCP	Y	Y	N	NN	512	8192	4096	64512	30	2	
2084-C24	211	H040331	ICP	2084,1	CNC,CTC,CVC,CFR,CFS,CBY,FC,FCV,CBR,CBS,OSD,OSE,CFP,CBP,ICP,IQD,FCP,OSC	Y	Y	Y	NN	1024	8192	4096	64512	30	4	
2084-D32	210	H030530	ICP	2084,1	CNC,CTC,CVC,CFR,CFS,CBY,FC,FCV,CBR,CBS,OSD,OSE,CFP,CBP,ICP,IQD,FCP	Y	Y	N	NN	512	8192	4096	64512	30	2	
2084-D32	211	H040331	ICP	2084,1	CNC,CTC,CVC,CFR,CFS,CBY,FC,FCV,CBR,CBS,OSD,OSE,CFP,CBP,ICP,IQD,FCP,OSC	Y	Y	Y	NN	1024	8192	4096	64512	30	4	
2086-A04	212	H040331	ICP	2086,1	CNC,CTC,CVC,CFR,CFS,CBY,FC,FCV,OSD,OSE,CFP,CBP,ICP,IQD,FCP,OSC	Y	Y	Y	NN	512	8192	4096	64512	30	2	
2094-S08	213	H050331	ICP	2094,1	CNC,CTC,CVC,CBY,FC,FCV,OSD,OSE,CFP,CBP,ICP,IQD,FCP,OSC,OSN	Y	Y	Y	NN	1024	8192	4096	65280	60	4	2
2094-S08	216	H070331	ICP	2094,1	CNC,CTC,CVC,CBY,FC,FCV,OSD,OSE,CFP,CBP,ICP,IQD,FCP,OSC,OSN,CIB	Y	Y	Y	NN	1024	8192	4096	65280	60	4	2
2094-S18	213	H050331	ICP	2094,1	CNC,CTC,CVC,CBY,FC,FCV,OSD,OSE,CFP,CBP,ICP,IQD,FCP,OSC,OSN	Y	Y	Y	NN	1024	8192	4096	65280	60	4	2
2094-S18	216	H070331	ICP	2094,1	CNC,CTC,CVC,CBY,FC,FCV,OSD,OSE,CFP,CBP,ICP,IQD,FCP,OSC,OSN,CIB	Y	Y	Y	NN	1024	8192	4096	65280	60	4	2
2094-S28	213	H050331	ICP	2094,1	CNC,CTC,CVC,CBY,FC,FCV,OSD,OSE,CFP,CBP,ICP,IQD,FCP,OSC,OSN	Y	Y	Y	NN	1024	8192	4096	65280	60	4	2
2094-S28	216	H070331	ICP	2094,1	CNC,CTC,CVC,CBY,FC,FCV,OSD,OSE,CFP,CBP,ICP,IQD,FCP,OSC,OSN,CIB	Y	Y	Y	NN	1024	8192	4096	65280	60	4	2
2094-S38	213	H050331	ICP	2094,1	CNC,CTC,CVC,CBY,FC,FCV,OSD,OSE,CFP,CBP,ICP,IQD,FCP,OSC,OSN	Y	Y	Y	NN	1024	8192	4096	65280	60	4	2
2094-S38	216	H070331	ICP	2094,1	CNC,CTC,CVC,CBY,FC,FCV,OSD,OSE,CFP,CBP,ICP,IQD,FCP,OSC,OSN,CIB	Y	Y	Y	NN	1024	8192	4096	65280	60	4	2
2094-S54	213	H050331	ICP	2094,1	CNC,CTC,CVC,CBY,FC,FCV,OSD,OSE,CFP,CBP,ICP,IQD,FCP,OSC,OSN	Y	Y	Y	NN	1024	8192	4096	65280	60	4	2
2094-S54	216	H070331	ICP	2094,1	CNC,CTC,CVC,CBY,FC,FCV,OSD,OSE,CFP,CBP,ICP,IQD,FCP,OSC,OSN,CIB	Y	Y	Y	NN	1024	8192	4096	65280	60	4	2
2096-R07	214	H060930	ICP	2096,1	CNC,CTC,CVC,CBY,FC,FCV,OSD,OSE,CFP,CBP,ICP,IQD,FCP,OSC,OSN	Y	Y	Y	NN	512	8192	4096	65280	15	2	2
2096-R07	218	H070331	ICP	2096,1	CNC,CTC,CVC,CBY,FC,FCV,OSD,OSE,CFP,CBP,ICP,IQD,FCP,OSC,OSN,CIB	Y	Y	Y	NN	512	8192	4096	65280	15	2	2
2096-S07	215	H060930	ICP	2096,1	CNC,CTC,CVC,CBY,FC,FCV,OSD,OSE,CFP,CBP,ICP,IQD,FCP,OSC,OSN	Y	Y	Y	NN	512	8192	4096	65280	30	2	2
2096-S07	219	H070331	ICP	2096,1	CNC,CTC,CVC,CBY,FC,FCV,OSD,OSE,CFP,CBP,ICP,IQD,FCP,OSC,OSN,CIB	Y	Y	Y	NN	512	8192	4096	65280	30	2	2
2097-E12	217	H080130	ICP	2097,1	CNC,CTC,CVC,CBY,FC,FCV,OSD,OSE,CFP,CBP,ICP,IQD,FCP,OSC,OSN,CIB	Y	Y	Y	NN	1024	8192	4096	65280	60	4	2
2097-E12	241	H080131	ICP	2097,1	CNC,CTC,CVC,CBY,FC,FCV,OSD,OSE,CFP,CBP,ICP,IQD,FCP,OSC,OSN,CIB	Y	Y	Y	NN	1024	8192	4096	65280	60	4	2
2097-E26	217	H080130	ICP	2097,1	CNC,CTC,CVC,CBY,FC,FCV,OSD,OSE,CFP,CBP,ICP,IQD,FCP,OSC,OSN,CIB	Y	Y	Y	NN	1024	8192	4096	65280	60	4	2
2097-E26	241	H080131	ICP	2097,1	CNC,CTC,CVC,CBY,FC,FCV,OSD,OSE,CFP,CBP,ICP,IQD,FCP,OSC,OSN,CIB	Y	Y	Y	NN	1024	8192	4096	65280	60	4	2
2097-E40	217	H080130	ICP	2097,1	CNC,CTC,CVC,CBY,FC,FCV,OSD,OSE,CFP,CBP,ICP,IQD,FCP,OSC,OSN,CIB	Y	Y	Y	NN	1024	8192	4096	65280	60	4	2
2097-E40	241	H080131	ICP	2097,1	CNC,CTC,CVC,CBY,FC,FCV,OSD,OSE,CFP,CBP,ICP,IQD,FCP,OSC,OSN,CIB	Y	Y	Y	NN	1024	8192	4096	65280	60	4	2
2097-E56	217	H080130	ICP	2097,1	CNC,CTC,CVC,CBY,FC,FCV,OSD,OSE,CFP,CBP,ICP,IQD,FCP,OSC,OSN,CIB	Y	Y	Y	NN	1024	8192	4096	65280	60	4	2

Figure 60. Supported Hardware Report - Processors (Part 5 of 26)

				SUPPORTED HARDWARE - PROCESSORS		TIME: 11:16 DATE: 2015-11-24 PAGE X- 6											
TYPE-MODEL	MOD	SUPLEVID	IOCP	SYSTEM	SUPPORTED	CHPID	WI	RI	DP	FCT	CHPID	CU	LCU	SUBCH	LPAR	CSS	SCHS
2097-E56	241	H080131	ICP	2097,1	CNC,CTC,CVC,CBY,FC,FCV,OSD,OSE,CFP,CBP,ICP,IQD,FCP,OSC,OSN,CIB	1024	Y	Y	Y	NN	1024	8192	4096	65280	60	4	2
2097-E64	217	H080130	ICP	2097,1	CNC,CTC,CVC,CBY,FC,FCV,OSD,OSE,CFP,CBP,ICP,IQD,FCP,OSC,OSN,CIB	1024	Y	Y	Y	NN	1024	8192	4096	65280	60	4	2
2098-E10	240	H081130	ICP	2098,1	CNC,CTC,CVC,CBY,FC,FCV,OSD,OSE,CFP,CBP,ICP,IQD,FCP,OSC,OSN,CIB	512	Y	Y	Y	NN	512	8192	4096	65280	30	2	2
2817-M15	242	H100331	ICP	2817,1	CNC,CTC,CVC,CBY,FC,OSD,OSE,CFP,ICP,IQD,FCP,OSC,OSN,CIB,OSX,OSM	1024	Y	Y	Y	NN	1024	8192	4096	65280	60	4	3
2817-M32	242	H100331	ICP	2817,1	CNC,CTC,CVC,CBY,FC,OSD,OSE,CFP,ICP,IQD,FCP,OSC,OSN,CIB,OSX,OSM	1024	Y	Y	Y	NN	1024	8192	4096	65280	60	4	3
2817-M49	242	H100331	ICP	2817,1	CNC,CTC,CVC,CBY,FC,OSD,OSE,CFP,ICP,IQD,FCP,OSC,OSN,CIB,OSX,OSM	1024	Y	Y	Y	NN	1024	8192	4096	65280	60	4	3
2817-M66	242	H100331	ICP	2817,1	CNC,CTC,CVC,CBY,FC,OSD,OSE,CFP,ICP,IQD,FCP,OSC,OSN,CIB,OSX,OSM	1024	Y	Y	Y	NN	1024	8192	4096	65280	60	4	3
2817-M80	242	H100331	ICP	2817,1	CNC,CTC,CVC,CBY,FC,OSD,OSE,CFP,ICP,IQD,FCP,OSC,OSN,CIB,OSX,OSM	1024	Y	Y	Y	NN	1024	8192	4096	65280	60	4	3
2818-M05	245	H110331	ICP	2818,1	CNC,CTC,CVC,CBY,FC,OSD,OSE,CFP,ICP,IQD,FCP,OSC,OSN,CIB,OSX,OSM	512	Y	Y	Y	NN	512	8192	4096	65280	30	2	2
2818-M10	245	H110331	ICP	2818,1	CNC,CTC,CVC,CBY,FC,OSD,OSE,CFP,ICP,IQD,FCP,OSC,OSN,CIB,OSX,OSM	512	Y	Y	Y	NN	512	8192	4096	65280	30	2	2
2827-HA1	244	H120331	ICP	2827,1	FC,OSD,OSE,CFP,ICP,IQD,FCP,OSC,OSN,CIB,OSX,OSM	1024	Y	Y	Y	NN	1024	8192	4096	65280	60	4	3
2827-HA1	247	H130331	ICP	2827,1	FC,OSD,OSE,CFP,ICP,IQD,FCP,OSC,OSN,CIB,OSX,OSM	1024	Y	Y	Y	YN	1024	8192	4096	65280	60	4	3
2827-H20	244	H120331	ICP	2827,1	FC,OSD,OSE,CFP,ICP,IQD,FCP,OSC,OSN,CIB,OSX,OSM	1024	Y	Y	Y	NN	1024	8192	4096	65280	60	4	3
2827-H20	247	H130331	ICP	2827,1	FC,OSD,OSE,CFP,ICP,IQD,FCP,OSC,OSN,CIB,OSX,OSM	1024	Y	Y	Y	YN	1024	8192	4096	65280	60	4	3
2827-H43	244	H120331	ICP	2827,1	FC,OSD,OSE,CFP,ICP,IQD,FCP,OSC,OSN,CIB,OSX,OSM	1024	Y	Y	Y	NN	1024	8192	4096	65280	60	4	3
2827-H43	247	H130331	ICP	2827,1	FC,OSD,OSE,CFP,ICP,IQD,FCP,OSC,OSN,CIB,OSX,OSM	1024	Y	Y	Y	YN	1024	8192	4096	65280	60	4	3
2827-H66	244	H120331	ICP	2827,1	FC,OSD,OSE,CFP,ICP,IQD,FCP,OSC,OSN,CIB,OSX,OSM	1024	Y	Y	Y	NN	1024	8192	4096	65280	60	4	3
2827-H66	247	H130331	ICP	2827,1	FC,OSD,OSE,CFP,ICP,IQD,FCP,OSC,OSN,CIB,OSX,OSM	1024	Y	Y	Y	YN	1024	8192	4096	65280	60	4	3
2827-H89	244	H120331	ICP	2827,1	FC,OSD,OSE,CFP,ICP,IQD,FCP,OSC,OSN,CIB,OSX,OSM	1024	Y	Y	Y	NN	1024	8192	4096	65280	60	4	3
2827-H89	247	H130331	ICP	2827,1	FC,OSD,OSE,CFP,ICP,IQD,FCP,OSC,OSN,CIB,OSX,OSM	1024	Y	Y	Y	YN	1024	8192	4096	65280	60	4	3
2828-H06	248	H130331	ICP	2828,1	FC,OSD,OSE,CFP,ICP,IQD,FCP,OSC,OSN,CIB,OSX,OSM,CS5	512	Y	Y	Y	YN	512	8192	4096	65280	30	2	2
2828-H13	248	H130331	ICP	2828,1	FC,OSD,OSE,CFP,ICP,IQD,FCP,OSC,OSN,CIB,OSX,OSM,CS5	512	Y	Y	Y	YN	512	8192	4096	65280	30	2	2
2964-NC9	250	H150111	ICP	2964,1	FC,OSD,OSE,ICP,IQD,FCP,OSC,OSN,CIB,OSX,OSM,CS5	1024	Y	Y	Y	YY	1024	8192	4096	65280	90	6	4
2964-NC9	252	H160310	ICP	2964,1	FC,OSD,OSE,ICP,IQD,FCP,OSC,OSN,CIB,OSX,OSM,CS5	1536	Y	Y	Y	YY	1536	8192	4096	65280	90	6	4
2964-NE1	250	H150111	ICP	2964,1	FC,OSD,OSE,ICP,IQD,FCP,OSC,OSN,CIB,OSX,OSM,CS5	1024	Y	Y	Y	YY	1024	8192	4096	65280	90	6	4
2964-NE1	252	H160310	ICP	2964,1	FC,OSD,OSE,ICP,IQD,FCP,OSC,OSN,CIB,OSX,OSM,CS5	1536	Y	Y	Y	YY	1536	8192	4096	65280	90	6	4
2964-N30	250	H150111	ICP	2964,1	FC,OSD,OSE,ICP,IQD,FCP,OSC,OSN,CIB,OSX,OSM,CS5	1024	Y	Y	Y	YY	1024	8192	4096	65280	90	6	4
2964-N30	252	H160310	ICP	2964,1	FC,OSD,OSE,ICP,IQD,FCP,OSC,OSN,CIB,OSX,OSM,CS5	1536	Y	Y	Y	YY	1536	8192	4096	65280	90	6	4
2964-N63	250	H150111	ICP	2964,1	FC,OSD,OSE,ICP,IQD,FCP,OSC,OSN,CIB,OSX,OSM,CS5	1024	Y	Y	Y	YY	1024	8192	4096	65280	90	6	4
2964-N63	252	H160310	ICP	2964,1	FC,OSD,OSE,ICP,IQD,FCP,OSC,OSN,CIB,OSX,OSM,CS5	1536	Y	Y	Y	YY	1536	8192	4096	65280	90	6	4
2964-N96	250	H150111	ICP	2964,1	FC,OSD,OSE,ICP,IQD,FCP,OSC,OSN,CIB,OSX,OSM,CS5	1024	Y	Y	Y	YY	1024	8192	4096	65280	90	6	4
2964-N96	252	H160310	ICP	2964,1	FC,OSD,OSE,ICP,IQD,FCP,OSC,OSN,CIB,OSX,OSM,CS5	1536	Y	Y	Y	YY	1536	8192	4096	65280	90	6	4
2965-N10	253	H160310	ICP	2965,1	FC,OSD,OSE,ICP,IQD,FCP,OSC,OSN,CIB,OSX,OSM,CS5	768	Y	Y	Y	YN	768	8192	4096	65280	45	3	3
2965-N20	253	H160310	ICP	2965,1	FC,OSD,OSE,ICP,IQD,FCP,OSC,OSN,CIB,OSX,OSM,CS5	768	Y	Y	Y	YN	768	8192	4096	65280	45	3	3

Figure 61. Supported Hardware Report - Processors (Part 6 of 26)

KEY	KEY DESCRIPTION
---	-----
TYPE-MODEL	- SUPPORTED PROCESSOR TYPE
MOD	- INDEX OF PROCESSOR SUPPORT MODULE
SUPLEVID	- SUPPORT LEVEL ID
IOCP	- PREFIX OF IOCP PROGRAM FOR THIS SUPPORT LEVEL
SYSTEM	- IOCP SYSTEM VALUE
SUPPORTED CHPID TYPES	- LIST OF CHANNEL PATH TYPES WHICH ARE SUPPORTED BY THIS CONTROL UNIT
WI	- WRITE IOCDS REGARDLESS OF CPC TYPE
RI	- RECEIVE IOCDS WRITTEN REGARDLESS OF CPC TYPE
DP	- SUPPORT OF DYNAMIC PARTITIONS
FCT	- SUPPORT OF PCIE FUNCTIONS
CHPID	- MAXIMUM NUMBER OF SUPPORTED CHPIDS
CU	- MAXIMUM NUMBER OF ATTACHABLE CONTROL UNITS
LCU	- MAXIMUM NUMBER OF LOGICAL CONTROL UNITS (PER CHANNEL SUBSYSTEM)
SUBCH	- MAXIMUM NUMBER OF SUBCHANNELS (PER CHANNEL SUBSYSTEM)
LPAR	- MAXIMUM NUMBER OF LOGICAL PARTITIONS
CSS	- MAXIMUM NUMBER OF CHANNEL SUBSYSTEMS (XMP PROCESSOR ONLY)
SCHS	- MAXIMUM NUMBER OF SUBCHANNEL SETS
Y	- PROCESSOR HAS THE CAPABILITY
N	- CAPABILITY IS NOT AVAILABLE

Figure 62. Supported Hardware Report - Processors (Part 7 of 26)

		SUPPORTED HARDWARE - CONTROL UNITS (1)				TIME: 11:16 DATE: 2015-11-24 PAGE X- 8
TYPE-MODEL	UIM U PROTCL DP IO	SUPPORTED	CHPID	TYPES	ATTACHABLE DEVICES	
AFP1	278 N D,S,S4 S 2	BL, BY, CNC, CVC, CBY, FCV, EIO			AFP1, AFP1-0, 2710, 3160, 3170, 3300, 3825, 3827, 3828, 3829, 3831, 3835, 3900, 3935, 4000, 4370	
CTC	270 N D D 2	BL, CVC, EIO			CTC, CTCA	
DUMMY	050 N D,S,S4 D 2	BL, BY, CNC, CTC, CVC, CBY, FCV, EIO			DUMMY	
FCP	254 N	FCP			FCP	
FCTC	270 N	FC			FCTC	
IQD	314 N	IQD			IQD	
NOCHECK	256 N D,S,S4 S 2	BL, BY, CNC, CTC, CVC, IOC, CBY, FC, FCV, EIO			AFP1-0, BCTC, BSC1, BSC2, BSC3, CTC, CTCA, DUMMY, FB512, FCTC, HFGD, ICABSCA, ICAELAN, ICAHDL, ICAILAN, ICASDL, ICATELE2, RS6K, SCTC, SWCH, TWX, WTTA, 1030, 1050, 1050X, 115A, 1287, 1288, 1403-N1, 1403-2, 1403-3, 1403-5, 1403-7, 2032, 2250-3, 2305-2, 2501-B1, 2501-B2, 2540P-1, 2540R-1, 2701, 2710, 2740, 2740C, 2741C, 2741P, 3088, 3151, 3160, 3161, 3162, 3163, 3167, 3170, 3172, 3174, 3178, 3179, 3180, 3180-1, 3190, 3191, 3192, 3192-F, 3193, 3194, 3203-4, 3203-5, 3211, 3215, 3250, 3251, 3262-13, 3262-3, 3262-5, 3268-2, 3270, 3270-X, 3272, 3274, 3277-1, 3277-2, 3278-1, 3278-2, 3278-2A, 3278-3, 3278-4, 3278-5, 3279-S2B, 3279-S3G, 3279-2, 3279-2A, 3279-2B, 3279-2C, 3279-2X, 3279-3, 3279-3A, 3279-3B, 3279-3X, 3284-1, 3284-2, 3286-1, 3286-2, 3287-1, 3287-1C, 3287-2, 3287-2C, 3288, 3289-1, 3289-2, 3290, 3300, 3330-1, 3330-11, 3330-2, 3330V, 3333-1, 3333-11, 3340, 3344, 3350, 3370, 3375, 3380, 3380-CJ2, 3380A, 3380B, 3390, 3390A, 3390B, 3420-3, 3420-4, 3420-5, 3420-6, 3420-7, 3420-8, 3422, 3423, 3424, 3430, 3471, 3472, 3480, 3481, 3483, 3490, 3505, 3525, 3540, 3590, 3704, 3705, 3720, 3725, 3737, 3745, 3746, 3767-1, 3767-2, 3791L, 3800-1, 3800-3, 3800-6, 3800-8, 3812, 3816, 3820, 3825, 3827, 3828, 3829, 3831, 3835, 3851, 3886, 3890, 3895, 3900, 3935, 3995, 3995-SDA, 3995-151, 3995-153, 4000, 4224, 4245, 4248, 4250, 4370, 5080, 5081, 5210, 6090, 6091, 6262, 7171, 7770-3, 8232, 83B3, 9032, 9032-3, 9032-5, 9033, 9332-40, 9332-42, 9332-60, 9332-62, 9335-B1, 9336-10, 9336-20, 9345, 9348-1	
OSA	314 N	OSA, OSD, OSE			CONTROL, OSA, OSAD	
OSC	314 N	OSC			3215, 3270-X, 3287-1, 3287-1C, 3287-2, 3287-2C	
OSM	314 N	OSM			OSA-M, OSAD	
OSN	314 N	OSN			OSAD, OSN, 3745	
OSX	314 N	OSX			OSA-X, OSAD	
RS6K	312 N D,S,S4 S4 2	BL, CNC, CVC, FCV, EIO			RS6K	
RS6K-2	312 N	CNC, FCV			RS6K	
SCTC	270 N	CNC, CTC, FCV			BCTC, CTCA, SCTC	
SWCH	307 Y	CNC, FCV			SWCH	
1287	288 N D D 2	BL, BY, CVC, CBY, EIO			1287	
1288	288 N D D 2	BL, BY, CVC, CBY, EIO			1288	
1750	258 Y S,S4 S 2	FC			3380, 3380A, 3380B, 3390, 3390A, 3390B	
2032	307 Y	FC			SWCH, 2032	
2105	258 Y S,S4 S 2	CNC, FC, FCV			3380, 3380A, 3380B, 3390, 3390A, 3390B	
2107	258 Y S,S4 S 2	CNC, FC, FCV			3380, 3380A, 3380B, 3390, 3390A, 3390B	
2501	268 N D D 2	BL, BY, CBY, EIO			2501	
2701	280 N D D 2	BL, BY, CVC, CBY, EIO			BSC1, BSC2, BSC3, TWX, WTTA, 1030, 1050, 1050X, 115A, 2701, 2740, 2740C, 2740X, 2741, 2741C, 2741P, 3151, 3161, 3162, 3163, 3167, 3767-1, 3767-2, 83B3	
2710	278 N D,S,S4 S 2	BL, CNC, CVC, FCV, EIO			AFP1-0, 2710	
2821	268 N D D 2	BL, BY, CVC, CBY, EIO			1403, 2540, 2540P-1, 2540R-1	
2835-2	269 N D D 2	BL, CVC, EIO			2305-2	
2840-2	277 N D D 2	BL, BY, CBY, EIO			2250-3	
3088	270 N D,S,S4 S 2	BL, CVC, EIO			CTC, CTCA, 3088	
3160	278 N D,S,S4 S 2	BL, BY, CNC, CVC, CBY, FCV, EIO			AFP1-0, 3160	
3170	278 N D,S,S4 S 2	BL, BY, CNC, CVC, CBY, FCV, EIO			AFP1-0, 3170	
3172	313 N D,S,S4 S4 2	BL, CNC, CVC, FCV, EIO			3172	
3174	283 N D,S D 2	BL, BY, CNC, CVC, CBY, FCV, EIO			3151, 3174, 3178, 3179, 3180, 3190, 3191, 3192, 3193, 3194, 3262, 3262-13, 3262-3, 3268, 3270, 3270-X, 3278, 3279, 3286, 3287, 3289, 3290, 3471, 3472, 3481, 3482, 3483, 3791L, 3812, 3816, 4201, 4202, 4207, 4208, 4224, 4234, 4245-D12, 4245-D20, 4250, 5210	
3203	268 N D D 2	BL, BY, CVC, CBY, EIO			3203	
3258	277 N D D 1	BL, CVC, EIO			2250-3, 3250, 3251	
3262	268 N D D 2	BL, BY, CVC, CBY, EIO			3262-5	
3272	283 N D D 2	BL, BY, CBY, EIO			3151, 3178, 3179, 3180, 3190, 3191, 3192, 3193, 3194, 3262, 3262-13, 3262-3, 3268, 3270, 3270-X, 3272, 3274, 3277, 3278, 3279, 3284, 3284-1, 3284-2, 3286, 3287, 3288, 3289, 3290, 3791L, 3812, 3816, 4224, 4234, 4245-D12, 4245-D20, 4250, 5210	
3274	283 N D D 2	BL, BY, CVC, CBY, EIO			3151, 3178, 3179, 3180, 3190, 3191, 3192, 3193, 3194, 3262, 3262-13, 3262-3, 3268, 3270, 3270-X, 3274, 3277, 3278, 3279, 3284, 3284-1, 3284-2, 3286, 3287, 3288, 3289, 3290, 3471, 3472, 3481, 3482, 3483, 3791L, 3812, 3816, 4224, 4234, 4245-D12, 4245-D20, 4250, 5210	
3300	278 N D,S,S4 S 2	BL, BY, CNC, CVC, CBY, FCV, EIO			AFP1-0, 3300	
3380-CJ2	258 N S S 2	BL, CVC, EIO			3380, 3380-CJ2	
3422	261 N D,S D 1	BL, CVC, EIO			3422	
3423	261 N D,S,S4 D 1	BL, CVC, EIO			3423	

Figure 63. Supported Hardware Report - Control Units (Part 8 of 26)

		SUPPORTED HARDWARE - CONTROL UNITS (1)				TIME: 11:16 DATE: 2015-11-24 PAGE X- 9	
TYPE-MODEL	UIM U	PROTCL	DP	IO	SUPPORTED CHPID TYPES	ATTACHABLE DEVICES	
3424	261	N	S	S	2	BL,CVC,EIO	3424
3430	261	N	D	D	1	BL,CVC,EIO	3430
3480	261	Y	D,S,S4	S	2	BL,CNC,CVC,FCV,EIO	3480
3490	261	Y	D,S,S4	S	2	BL,CNC,CVC,ISD,FC,FCV,EIO	3490
3490-C1A	261	Y	D,S,S4	S	2	BL,CNC,CVC,FC,FCV,EIO	3490
3490-C10	261	Y	D,S,S4	S	2	BL,CNC,CVC,ISD,FC,FCV,EIO	3490
3490-C11	261	Y	D,S,S4	S	2	BL,CNC,CVC,ISD,FC,FCV,EIO	3490
3490-C2A	261	Y	D,S,S4	S	2	BL,CNC,CVC,FC,FCV,EIO	3490
3490-C22	261	Y	D,S,S4	S	2	BL,CNC,CVC,FC,FCV,EIO	3490
3505	268	N	D	D	2	BL,BY,CVC,CBY,EIO	3505,3525
3540	288	N	D	D	2	BL,BY,CVC,CBY,EIO	3540
3590	261	Y	D,S,S4	S	2	BL,CNC,CVC,FC,FCV,EIO	3590
3704	279	N	D	D	2	BY,CBY	BSC1,BSC2,BSC3,TWX,WTTA,1030,1050,1050X,115A,2740,2740C,2740X,2741C,2741P,3151,3161,3162,3163,3167,3174,3232,3271,3274,3276,3704,3767-1,3767-2,3791L,83B3
3705	279	N	D	D	2	BL,BY,CNC,CVC,CBY,FCV,EIO	BSC1,BSC2,BSC3,NCP,TWX,WTTA,1030,1050,1050X,115A,2740,2740C,2740X,2741C,2741P,3151,3161,3162,3163,3167,3174,3232,3271,3274,3276,3705,3767-1,3767-2,3791L,83B3
3720	279	N	D	D	2	BL,BY,CVC,CBY,EIO	BSC1,BSC2,BSC3,NCP,TWX,WTTA,1030,1050,1050X,115A,2740,2740C,2740X,2741C,2741P,3151,3161,3162,3163,3167,3174,3232,3271,3274,3276,3720,3767-1,3767-2,3791L,83B3
3725	279	N	D	D	2	BL,BY,CVC,CBY,EIO	BSC1,BSC2,BSC3,NCP,TWX,WTTA,1030,1050,1050X,115A,2740,2740C,2740X,2741C,2741P,3161,3162,3163,3167,3174,3232,3271,3274,3276,3725,3767-1,3767-2,3791L,83B3
3737	270	N	D,S	S	2	BL,CVC,EIO	CTC,CTCA,3737,4753
3745	279	N	D,S	D	2	BL,BY,CNC,CVC,CBY,FCV,EIO	BSC1,BSC2,BSC3,NCP,TWX,WTTA,1030,1050,1050X,115A,2740,2740C,2740X,2741C,2741P,3161,3162,3163,3167,3174,3232,3271,3274,3276,3745,3767-1,3767-2,3791L,83B3
3746	279	N	D,S	D	2	BL,BY,CNC,CVC,CBY,FCV,EIO	BSC1,BSC2,BSC3,NCP,TWX,WTTA,1030,1050,1050X,115A,2740,2740C,2740X,2741C,2741P,3174,3232,3271,3274,3276,3745,3767-1,3767-2,3791L,83B3
3791L	283	N	D,S	D	2	BL,BY,CNC,CVC,CBY,FCV,EIO	3151,3178,3179,3180,3190,3191,3192,3193,3194,3262,3262-13,3262-3,3268,3270,3270-X,3272,3277,3278,3279,3284-1,3284-2,3286,3287,3288,3289,3290,3791L,3812,3816,4224,4234,4245-D12,4245-D20,4250,5210
3800-1	267	N	D,S	D	2	BL,BY,CVC,CBY,EIO	3800-1
3800-3	267	N	D,S	D	2	BL,BY,CVC,CBY,EIO	AFP1,3800-3
3800-6	267	N	D,S	D	2	BL,BY,CVC,CBY,EIO	AFP1,3800-6
3800-8	267	N	D,S	D	2	BL,BY,CVC,CBY,EIO	AFP1,3800-8
3803	261	N	D	D	1	BL,CVC,EIO	3420
3811	268	N	D	D	2	BL,BY,CVC,CBY,EIO	3211,3216
3820	278	N	D,S4	D	2	BL,BY,CNC,CVC,CBY,FCV,EIO	AFP1,3820
3825	278	N	D,S,S4	S	2	BL,BY,CNC,CVC,CBY,FCV,EIO	AFP1,AFP1-0,3825
3827	278	N	D,S	S	2	BL,BY,CVC,CBY,EIO	AFP1,AFP1-0,3827
3828	278	N	D,S	S	2	BL,BY,CVC,CBY,EIO	AFP1,AFP1-0,3828
3829	278	N	D,S,S4	S	2	BL,BY,CNC,CVC,CBY,FCV,EIO	AFP1-0,3829
3830-2	257	N	D	D	2	BL,CVC,EIO	3330-1,3330-11,3330-2,3333-1,3333-11,3340,3344,3350
3830-3	271	N	D	D	2	BL,CVC,EIO	3330-11,3330V,3350
3831	278	N	D,S	S	2	BL,BY,CVC,CBY,EIO	AFP1-0,3831
3835	278	N	D,S	S	2	BL,BY,CVC,CBY,EIO	AFP1,AFP1-0,3835
3851	271	N	D	D	2	BL,BY,CVC,CBY,EIO	3851
3880-1	258	N	D,S	S	2	BL,CVC,EIO	3330-1,3330-11,3330-2,3333-1,3333-11,3340,3344,3350,3370,3375
3880-11	259	N	D,S	S	2	BL,CVC,EIO	3370,3375
3880-13	258	N	D	D	2	BL,CVC,EIO	3380
3880-2	258	N	D,S	S	2	BL,CVC,FC,FCV,EIO	3330-1,3330-11,3330-2,3333-1,3333-11,3340,3350,3370,3375,3380
3880-23	258	N	D	D	2	BL,CVC,EIO	3380
3880-3	258	N	D,S	S	2	BL,CVC,FC,FCV,EIO	3380
3880-4	258	N	D,S	S	2	BL,CVC,EIO	3375
3886	288	N	D	D	2	BL,BY,CVC,CBY,EIO	3886
3890	288	N	D	D	2	BL,BY,CVC,CBY,EIO	3890
3895	288	N	D	D	2	BL,BY,CVC,CBY,EIO	3895
3900	278	N	D,S,S4	S	2	BL,BY,CNC,CVC,CBY,FCV,EIO	AFP1,AFP1-0,3900
3935	278	N	D,S,S4	S	2	BL,BY,CNC,CVC,CBY,FCV,EIO	AFP1-0,3935
3990	258	Y	S,S4	S	2	BL,CNC,CVC,ISD,DSD,FC,FCV,EIO	3380,3390
3990-1	258	N	S	S	2	BL,CVC,EIO	3380
3990-2	258	Y			2	BL,CNC,CVC,ISD,DSD,FCV,EIO	3380,3390
3990-3	258	Y			2	BL,CNC,CVC,FCV,EIO	3380,3390
3990-6	258	Y	S,S4	S	2	BL,CNC,CVC,FC,FCV,EIO	3380,3390
3995	309	Y	D,S,S4	S4	2	BL,CNC,CVC,FCV,EIO	3995
3995-SDA	309	Y	D,S,S4	S4	2	BL,CNC,CVC,FCV,EIO	3995,3995-SDA
3995-151	258	Y	S,S4	S	2	BL,CNC,CVC,FC,FCV,EIO	3995-151
3995-153	258	Y	S,S4	S	2	BL,CNC,CVC,FC,FCV,EIO	3995-153
4000	278	N	D,S,S4	S	2	BL,BY,CNC,CVC,CBY,FCV,EIO	AFP1-0,4000

Figure 64. Supported Hardware Report - Control Units (Part 9 of 26)

SUPPORTED HARDWARE - CONTROL UNITS (1)										TIME: 11:16	DATE: 2015-11-24	PAGE X- 10
TYPE-MODEL	UIM	U	PROTCL	DP	IO	SUPPORTED CHPID TYPES	ATTACHABLE DEVICES					
4245	268	N	D	D	2	BL,BY,CVC,CBY,EIO	4245					
4248	268	N	D	D	2	BL,BY,CVC,CBY,EIO	3262,4248,6262					
4370	278	N	D,S,S4	S	2	BL,BY,CNC,CVC,CBY,FCV,EIO	AFP1-0,4370					
5088-1	291	N	D,S	D	2	BL,CVC,EIO	HFGD,3251,3279-2B,3279-3B,5080,5081,6090,6091					
5088-2	291	N	D,S	D	2	BL,CVC,EIO	HFGD,3251,3279-2B,3279-3B,5080,5081,6090,6091					
6098	291	N	S,S4	S	2	BL,CVC,EIO	HFGD,3251,3279-2B,3279-3B,5080,5081,6090,6091					
6120	308	N			2	IOC,EIO	3101,3151,3174,3178,3179,3180,3190,3191,3192,3193,3194,3262,3268,3270,3277,3278,3279,3286,3287,3289,3290,3812,3816,4224,4245,4250,5210					
6135	308	N			1	IOC,EIO	ICAE LAN					
6139	308	N			1	IOC,EIO	ICAILAN					
6140	308	N			1	IOC,EIO	ICAILAN					
6241	308	N			1	IOC,EIO	ICATELE2					
6242	308	N			1	IOC,EIO	ICATELE2					
6243	308	N			1	IOC,EIO	ICATELE2					
6244	308	N			1	IOC,EIO	ICATELE2					
6251	308	N			1	IOC,EIO	ICABSCA,ICAHDL,ICASDLC,ICATELE2					
6252	308	N			1	IOC,EIO	ICABSCA,ICAHDL,ICASDLC,ICATELE2					
6253	308	N			1	IOC,EIO	ICABSCA,ICAHDL,ICASDLC,ICATELE2					
6254	308	N			1	IOC,EIO	ICABSCA,ICAHDL,ICASDLC,ICATELE2					
6255	308	N			1	IOC,EIO	ICABSCA,ICAHDL,ICASDLC,ICATELE2					
6256	308	N			1	IOC,EIO	ICABSCA,ICAHDL,ICASDLC,ICATELE2					
6257	308	N			1	IOC,EIO	ICABSCA,ICAHDL,ICASDLC,ICATELE2					
6258	308	N			1	IOC,EIO	ICABSCA,ICAHDL,ICASDLC,ICATELE2					
6262	268	N	D	D	2	BL,BY,CVC,CBY,EIO	6262					
6310	308	N			2	IOC,EIO	FB512,9332,9335,9336					
6311	308	N			2	IOC,EIO	9348					
7171	283	N	D	D	2	BL,CVC,EIO	3161,3162,3163,3277,3278,3279,3286,3791L,7171					
7770-3	279	N	D	D	2	BY,CBY	7770-3					
8232	270	N	D,S,S4	S	2	BL,CVC,EIO	8232					
9032	307	Y			2	CNC	SWCH,9032					
9032-3	307	Y			2	CNC	SWCH,9032-3					
9032-5	307	Y			2	CNC,FCV	SWCH,9032-5					
9033	307	Y			2	CNC	SWCH,9033					
9340	258	Y	S,S4	S	2	BL,CNC,CVC,FC,FCV,EIO	9345					
9341	258	Y	S,S4	S	2	BL,CNC,CVC,FC,FCV,EIO	9345					
9343	258	Y	S,S4	S	2	BL,CNC,CVC,FC,FCV,EIO	9345					
9343-1	258	Y	S,S4	S	2	BL,CNC,CVC,FC,FCV,EIO	9345					

Figure 65. Supported Hardware Report - Control Units (Part 10 of 26)

SUPPORTED HARDWARE - CONTROL UNITS (1)		TIME: 11:16	DATE: 2015-11-24	PAGE X- 11
KEY	KEY DESCRIPTION			
---	-----			
TYPE-MODEL	- SUPPORTED CONTROL UNIT TYPE			
UIM	- INDEX OF UNIT INFORMATION MODULE SUPPORTING THIS CONTROL UNIT TYPE			
U	- If Y, INDICATES THAT THE UNIT ADDRESS RANGE MUST START WITH 00			
	- WHEN THE CONTROL UNIT IS CONNECTED TO AN ESCON CHANNEL PATH			
DP	- DEFAULT PROTOCOL FOR PARALLEL CONTROL UNIT			
IO	- DEFAULT I/O CONCURRENCY LEVEL FOR PARALLEL CONTROL UNIT			
PROTCL	- PROTOCOL SUPPORTED BY THE CONTROL UNIT TYPE			
SUPPORTED CHPID TYPES	- LIST OF CHANNEL PATH TYPES WHICH ARE SUPPORTED BY THIS CONTROL UNIT TYPE			
ATTACHABLE DEVICES	- LIST OF ATTACHABLE DEVICE TYPES			

Figure 66. Supported Hardware Report - Control Units (Part 11 of 26)

--CONTROL UNIT-- TYPE-MODEL	MD	-ATTACHMENT COUNTS--			SUPPORTED HARDWARE -UNIT ADDRESSES--			- CONTROL UNITS (2) ----LOGICAL ADDRESSING---				-----LOGICAL PATH -----				DCM		
		CHPMAX	DEVMIN	DEVMAX	MIN	MAX	REC RANGE	LA	MIN	MAX	MULTHOST	MAXCU	MAXPATH	MINGRP	SH		MXESC	MXFIC
AFP1	-	-	-	-	-	-	-	N	-	-	-	-	-	-	-	-	-	NN
CTC	-	-	-	-	-	-	-	N	-	-	-	-	-	-	-	-	-	NN
DUMMY	-	-	-	-	-	-	-	Y	0	F	N	-	-	-	-	-	-	NY
FCP	-	1	-	-	-	-	-	N	-	-	-	-	-	-	-	-	-	NN
FCTC	-	1	-	-	-	-	-	Y	-	-	Y	-	-	-	-	-	-	NN
IQD	-	1	3	256	-	-	1	Y	-	-	Y	-	-	-	-	-	-	NN
NOCHECK	-	8	-	-	-	-	-	Y	00	FF	Y	-	-	-	-	-	-	YY
OSA	-	1	1	255	-	-	-	Y	-	-	Y	-	-	-	-	-	-	NN
OSC	-	1	1	254	-	-	1	Y	-	-	Y	-	-	-	-	-	-	NN
OSM	-	1	1	255	-	-	-	Y	-	-	Y	-	-	-	-	-	-	NN
OSN	-	1	-	255	-	-	1	N	-	-	-	-	-	-	-	-	-	NN
OSX	-	1	1	255	-	-	-	Y	-	-	Y	-	-	-	-	-	-	NN
RS6K	-	1	-	-	-	-	-	Y	-	-	Y	-	-	-	-	-	-	NN
RS6K-2	N	1	-	-	-	-	-	Y	-	-	Y	-	-	-	-	-	-	NN
SCTC	-	1	-	-	-	-	-	Y	-	-	Y	-	-	-	-	-	-	NN
SWCH	-	-	-	1	-	-	-	N	-	-	-	-	-	-	-	-	-	NN
1287	-	-	-	1	-	-	-	N	-	-	-	-	-	-	-	-	-	NN
1288	-	-	-	1	-	-	-	N	-	-	-	-	-	-	-	-	-	NN
1750	-	-	-	256	-	-	-	Y	00	3F	Y	-	128	2	-	1024	-	YN
2032	-	-	-	1	-	-	-	N	-	-	-	-	-	-	-	-	-	NN
2105	-	-	-	256	-	-	-	Y	00	FE	Y	-	2048	2	-	64	-	YN
2107	-	-	-	256	-	-	-	Y	00	FE	Y	-	512	2	-	64	2048	YN
2501	-	-	-	-	-	-	-	N	-	-	-	-	-	-	-	-	-	NN
2701	-	-	-	-	-	-	-	N	-	-	-	-	-	-	-	-	-	NN
2710	-	-	-	-	-	-	-	N	-	-	-	-	-	-	-	-	-	NN
2821	-	-	-	-	-	-	-	N	-	-	-	-	-	-	-	-	-	NN
2835-2	N	-	-	2	-	-	16	N	-	-	-	-	-	-	-	-	-	NN
2840-2	N	-	-	4	-	-	-	N	-	-	-	-	-	-	-	-	-	NN
3088	-	-	-	-	-	-	-	N	-	-	-	-	-	-	-	-	-	NN
3160	-	-	-	-	-	-	-	N	-	-	-	-	-	-	-	-	-	NN
3170	-	-	-	-	-	-	-	N	-	-	-	-	-	-	-	-	-	NN
3172	-	2	-	-	-	-	-	Y	-	-	Y	-	-	-	-	-	-	NN
3174	-	-	-	256	-	-	32	Y	0	F	Y	-	8	-	-	-	-	NN
3203	-	-	-	-	-	-	-	N	-	-	-	-	-	-	-	-	-	NN
3258	-	-	-	16	-	-	-	N	-	-	-	-	-	-	-	-	-	NN
3262	-	-	-	1	-	-	-	N	-	-	-	-	-	-	-	-	-	NN
3272	-	-	-	32	-	-	32	N	-	-	-	-	-	-	-	-	-	NN
3274	-	-	-	32	-	-	-	N	-	-	-	-	-	-	-	-	-	NN
3300	-	-	-	-	-	-	-	N	-	-	-	-	-	-	-	-	-	NN
3380-CJ2	N	-	-	64	-	-	-	Y	0	F	N	-	-	-	-	-	-	NN
3422	-	-	-	16	-	-	-	N	-	-	-	-	-	-	-	-	-	NN
3423	-	-	-	16	-	-	-	N	-	-	-	-	-	-	-	-	-	NN
3424	-	-	-	8	-	-	8	N	-	-	-	-	-	-	-	-	-	NN
3430	-	-	-	16	-	-	-	N	-	-	-	-	-	-	-	-	-	NN
3480	-	-	-	16	16	16	-	N	-	-	-	-	-	-	-	-	-	NN
3490	-	-	-	16	16	16	-	Y	00	FE	Y	-	-	-	-	-	-	NN
3490-C1A	N	-	-	16	2	16	-	Y	00	FE	Y	-	-	-	-	-	-	NN
3490-C10	N	-	-	16	2	16	-	Y	00	FE	Y	-	-	-	-	-	-	NN
3490-C11	N	-	-	16	2	16	-	Y	00	FE	Y	-	-	-	-	-	-	NN
3490-C2A	N	-	-	16	2	16	-	Y	00	FE	Y	-	-	-	-	-	-	NN
3490-C22	N	-	-	16	2	16	-	Y	00	FE	Y	-	-	-	-	-	-	NN
3505	-	-	-	-	-	-	-	N	-	-	-	-	-	-	-	-	-	NN
3540	-	-	-	1	-	-	-	N	-	-	-	-	-	-	-	-	-	NN
3590	-	-	-	16	1	16	-	Y	00	FE	Y	-	-	-	-	-	-	NN
3704	-	-	-	-	-	-	-	N	-	-	-	-	-	-	-	-	-	NN
3705	-	-	-	-	-	-	-	N	-	-	-	-	-	-	-	-	-	NN
3720	-	-	-	-	-	-	-	N	-	-	-	-	-	-	-	-	-	NN
3725	-	-	-	-	-	-	-	N	-	-	-	-	-	-	-	-	-	NN
3737	-	-	-	-	-	-	-	N	-	-	-	-	-	-	-	-	-	NN
3745	-	-	-	-	-	-	-	N	-	-	-	-	-	-	-	-	-	NN
3746	-	-	-	-	-	-	-	N	-	-	-	-	-	-	-	-	-	NN
3791L	-	-	-	256	-	-	32	Y	0	F	Y	-	8	-	-	-	-	NN
3800-1	Y	-	-	-	-	-	-	N	-	-	-	-	-	-	-	-	-	NN
3800-3	N	-	-	-	-	-	-	N	-	-	-	-	-	-	-	-	-	NN
3800-6	N	-	-	-	-	-	-	N	-	-	-	-	-	-	-	-	-	NN
3800-8	N	-	-	-	-	-	-	N	-	-	-	-	-	-	-	-	-	NN
3803	-	-	-	16	-	-	-	N	-	-	-	-	-	-	-	-	-	NN
3811	-	-	-	1	-	-	-	N	-	-	-	-	-	-	-	-	-	NN
3820	-	-	-	1	-	-	-	N	-	-	-	-	-	-	-	-	-	NN
3825	-	-	-	-	-	-	-	N	-	-	-	-	-	-	-	-	-	NN
3827	-	-	-	-	-	-	-	N	-	-	-	-	-	-	-	-	-	NN

Figure 67. Supported Hardware Report - Control Units (Part 12 of 26)

--CONTROL UNIT--		-ATTACHMENT COUNTS--			SUPPORTED HARDWARE -UNIT ADDRESSES--				- CONTROL UNITS (2) -----LOGICAL ADDRESSING---				TIME: 11:16 DATE: 2015-11-24 PAGE X- 13				DCM			
TYPE-MODEL	MD	CHP	DEV	DEVM	MIN	MAX	REC	RANGE	LA	MIN	MAX	MULT	HOST	MAXCU	MAXPATH	MINGRP	SH	MXESC	MXFIC	DCM
3828	-	-	-	-	-	-	-	-	N	-	-	-	-	-	-	-	-	-	-	NN
3829	-	-	-	-	-	-	-	-	N	-	-	-	-	-	-	-	-	-	-	NN
3830-2	N	-	-	64	-	-	-	-	N	-	-	-	-	-	-	-	-	-	-	NN
3830-3	N	-	-	64	-	-	-	-	N	-	-	-	-	-	-	-	-	-	-	NN
3831	-	-	-	-	-	-	-	-	N	-	-	-	-	-	-	-	-	-	-	NN
3835	-	-	-	-	-	-	-	-	N	-	-	-	-	-	-	-	-	-	-	NN
3851	-	-	-	64	-	-	-	-	N	-	-	-	-	-	-	-	-	-	-	NN
3880-1	N	-	-	64	-	-	-	-	N	-	-	-	-	-	-	-	-	-	-	NN
3880-11	N	-	-	64	-	-	32	-	N	-	-	-	-	-	-	-	-	-	-	NN
3880-13	N	-	-	64	-	-	-	-	N	-	-	-	-	-	-	-	-	-	-	NN
3880-2	N	-	-	64	-	-	-	-	N	-	-	-	-	-	-	-	-	-	-	YN
3880-23	Y	-	-	64	-	-	-	-	N	-	-	-	-	-	-	-	-	-	-	NN
3880-3	N	-	-	256	-	-	-	-	N	-	-	-	-	-	-	-	-	-	-	YN
3880-4	N	-	-	64	-	-	-	-	N	-	-	-	-	-	-	-	-	-	-	NN
3886	-	-	-	2	-	-	-	-	N	-	-	-	-	-	-	-	-	-	-	NN
3890	-	-	-	2	-	-	-	-	N	-	-	-	-	-	-	-	-	-	-	NN
3895	-	-	-	2	-	-	-	-	N	-	-	-	-	-	-	-	-	-	-	NN
3900	-	-	-	-	-	-	-	-	N	-	-	-	-	-	-	-	-	-	-	NN
3935	-	-	-	-	-	-	-	-	N	-	-	-	-	-	-	-	-	-	-	NN
3990	-	-	-	256	-	-	-	-	Y	00	10	Y	-	-	-	-	-	-	-	YN
3990-1	N	-	-	64	-	-	-	-	N	-	-	-	-	-	8	8	-	-	-	NN
3990-2	N	-	-	256	-	-	-	-	Y	0	F	Y	-	-	16	8	-	-	-	YN
3990-3	N	-	-	64	-	-	-	-	Y	0	F	Y	-	-	16	8	-	-	-	YN
3990-6	N	-	-	256	-	-	-	-	Y	00	10	Y	-	-	128	8	-	-	-	YN
3995	-	2	-	-	-	-	-	-	N	-	-	-	-	-	-	-	Y	-	-	NN
3995-SDA	N	2	-	256	2	256	16	1	N	-	-	-	-	-	-	-	Y	-	-	NN
3995-151	N	-	-	96	-	-	-	-	Y	00	10	Y	-	-	-	-	-	-	-	YN
3995-153	N	-	-	96	-	-	-	-	Y	00	10	Y	-	-	-	-	-	-	-	YN
4000	-	-	-	-	-	-	-	-	N	-	-	-	-	-	-	-	-	-	-	NN
4245	-	-	-	1	-	-	-	-	N	-	-	-	-	-	-	-	-	-	-	NN
4248	-	-	-	1	-	-	-	-	N	-	-	-	-	-	-	-	-	-	-	NN
4370	-	-	-	-	-	-	-	-	N	-	-	-	-	-	-	-	-	-	-	NN
5088-1	N	-	-	16	-	-	-	-	N	-	-	-	-	-	-	-	-	-	-	NN
5088-2	Y	-	-	32	-	-	-	-	N	-	-	-	-	-	-	-	-	-	-	NN
6098	-	-	-	192	-	-	-	-	N	-	-	-	-	-	-	-	-	-	-	NN
6120	-	-	-	-	-	-	-	-	N	-	-	-	-	-	-	-	-	-	-	NN
6135	-	-	-	-	-	-	-	-	N	-	-	-	-	-	-	-	-	-	-	NN
6139	-	-	-	-	-	-	-	-	N	-	-	-	-	-	-	-	-	-	-	NN
6140	-	-	-	-	-	-	-	-	N	-	-	-	-	-	-	-	-	-	-	NN
6241	-	-	-	-	-	-	-	-	N	-	-	-	-	-	-	-	-	-	-	NN
6242	-	-	-	-	-	-	-	-	N	-	-	-	-	-	-	-	-	-	-	NN
6243	-	-	-	-	-	-	-	-	N	-	-	-	-	-	-	-	-	-	-	NN
6244	-	-	-	-	-	-	-	-	N	-	-	-	-	-	-	-	-	-	-	NN
6251	-	-	-	-	-	-	-	-	N	-	-	-	-	-	-	-	-	-	-	NN
6252	-	-	-	-	-	-	-	-	N	-	-	-	-	-	-	-	-	-	-	NN
6253	-	-	-	-	-	-	-	-	N	-	-	-	-	-	-	-	-	-	-	NN
6254	-	-	-	-	-	-	-	-	N	-	-	-	-	-	-	-	-	-	-	NN
6255	-	-	-	-	-	-	-	-	N	-	-	-	-	-	-	-	-	-	-	NN
6256	-	-	-	-	-	-	-	-	N	-	-	-	-	-	-	-	-	-	-	NN
6257	-	-	-	-	-	-	-	-	N	-	-	-	-	-	-	-	-	-	-	NN
6258	-	-	-	-	-	-	-	-	N	-	-	-	-	-	-	-	-	-	-	NN
6262	-	-	-	1	-	-	-	-	N	-	-	-	-	-	-	-	-	-	-	NN
6310	-	-	-	64	-	-	-	-	N	-	-	-	-	-	-	-	-	-	-	NN
6311	-	-	-	64	-	-	-	-	N	-	-	-	-	-	-	-	-	-	-	NN
7171	-	-	-	64	-	-	32	-	N	-	-	-	-	-	-	-	-	-	-	NN
7770-3	N	-	-	-	-	-	-	-	N	-	-	-	-	-	-	-	-	-	-	NN
8232	-	-	-	-	-	-	-	-	N	-	-	-	-	-	-	-	-	-	-	NN
9032	-	-	-	1	-	-	-	-	N	-	-	-	-	-	-	-	-	-	-	NN
9032-3	N	-	-	1	-	-	-	-	N	-	-	-	-	-	-	-	-	-	-	NN
9032-5	N	-	-	1	-	-	-	-	N	-	-	-	-	-	-	-	-	-	-	NN
9033	-	-	-	1	-	-	-	-	N	-	-	-	-	-	-	-	-	-	-	NN
9340	-	-	-	256	-	-	-	-	N	-	-	-	-	-	64	64	-	-	-	YN
9341	-	-	-	16	-	-	-	-	N	-	-	-	-	-	2	2	-	-	-	YN
9343	-	-	-	64	-	-	-	-	N	-	-	-	-	-	64	64	-	-	-	YN
9343-1	N	-	-	64	-	-	-	-	N	-	-	-	-	-	64	64	-	-	-	YN

Figure 68. Supported Hardware Report - Control Units (Part 13 of 26)

KEY	KEY DESCRIPTION
-----	
TYPE-MODEL	- SUPPORTED CONTROL UNIT TYPE
MD	- IF Y, MODEL IS DEFAULT
ATTACHMENT CNT	CHPMAX - MAXIMUM NUMBER OF CHANNEL PATHS THAT CAN BE CONNECTED TO C/U
	DEVMIN - MINIMUM NUMBER OF DEVICES THAT MUST BE CONNECTED TO C/U
	DEVMAX - MAXIMUM NUMBER OF DEVICES THAT CAN BE CONNECTED TO C/U
UNIT ADDRESSES	MIN - MINIMUM NUMBER OF UNIT ADDRESSES THAT MUST BE DEFINED TO C/U
	MAX - MAXIMUM NUMBER OF UNIT ADDRESSES THAT CAN BE DEFINED TO C/U
	REC - RECOMMENDED NUMBER OF UNIT ADDRESSES
	RANGE - MAXIMUM NUMBER OF UNIT ADDRESS RANGES THAT CAN BE DEFINED TO C/U
LOGICAL ADDRESSING	LA - IF Y, C/U SUPPORTS LOGICAL ADDRESSING (CUADD)
	MIN - MINIMUM VALUE OF ALLOWED LOGICAL ADDRESS (CUADD)
	MAX - MAXIMUM VALUE OF ALLOWED LOGICAL ADDRESS (CUADD)
	MULTHOST - IF Y, MULTIPLE HOSTS CAN CONNECT TO THE SAME LOGICAL ADDRESS (CUADD)
	MAXCU - MAXIMUM NUMBER OF LOGICAL CONTROL UNITS SUPPORTED (CUADD)
LOGICAL PATHS	MAXPATH - MAXIMUM NUMBER OF LOGICAL PATHS SUPPORTED BY C/U
	MINGRP - MINIMUM GROUP ATTACHMENT VALUE FOR LOGICAL PATHS
	SH - IF Y, ONLY SINGLE HOST CAN ATTACH TO CONTROL UNIT AT A TIME
	MXESC - MAXIMUM NUMBER OF LOGICAL PATHS PER ESCON PORT
	MXFIC - MAXIMUM NUMBER OF LOGICAL PATHS PER FICON PORT
DCM	- DYNAMIC CHPID MANAGEMENT SUPPORT
Y	- CONTROL UNIT HAS THE CAPABILITY
N	- CONTROL UNIT DOES NOT HAVE THE CAPABILITY
-	- UIM DOES NOT DEFINE A VALUE OR VALUE IS NOT APPLICABLE

Figure 69. Supported Hardware Report - Control Units (Part 14 of 26)

TYPE-MODEL	UIM	MVS	VM	MX	GR	RL	RH	RD	TM	ST	ATTACHABLE	TO	CU
AFP1-0	278	N	Y	N	N	1	4095	1	Y	Y	AFP1, NOCHECK, 2710, 3160, 3170, 3300, 3800-3, 3800-6, 3800-8, 3820, 3825, 3827, 3828, 3829, 3831, 3835, 3900, 3935, 4000, 4370		
BCTC	270	N	Y	N	N	1	4095	1	N	Y	NOCHECK, SCTC		
BSC1	282	N	Y	N	N	1	4095	1	Y	Y	NOCHECK, 2701, 3704, 3705, 3720, 3725, 3745, 3746		
BSC2	282	N	Y	N	N	1	4095	1	Y	Y	NOCHECK, 2701, 3704, 3705, 3720, 3725, 3745, 3746		
BSC3	282	N	Y	N	N	1	4095	1	Y	Y	NOCHECK, 2701, 3704, 3705, 3720, 3725, 3745, 3746		
CTC	270	N	Y	N	N	1	4095	1	N	Y	CTC, NOCHECK, 3088, 3737		
CTCA	270	N	Y	N	N	1	4095	1	N	Y	CTC, NOCHECK, SCTC, 3088, 3737		
DUMMY	050	Y	Y	N	N	1	4095	1	Y	Y	DUMMY, NOCHECK		
FBASCSI	254	N	Y	N	N	1	4095	1	Y	Y			
FB512	258	N	Y	N	N	1	4095	1	Y	Y	NOCHECK, 6310		
FCP	254	N	Y	N	N	1	4095	1	N	N	FCP		
FCTC	270	N	Y	N	N	1	4095	1	N	Y	FCTC, NOCHECK		
HFGD	291	N	Y	N	N	1	4095	1	Y	Y	NOCHECK, 5088-1, 5088-2, 6098		
ICABSCA	308	N	Y	N	N	1	4095	1	Y	Y	NOCHECK, 6251, 6252, 6253, 6254, 6255, 6256, 6257, 6258		
ICAE LAN	308	N	Y	N	N	1	4095	1	Y	Y	NOCHECK, 6135		
ICAHDL C	308	N	Y	N	N	1	4095	1	Y	Y	NOCHECK, 6251, 6252, 6253, 6254, 6255, 6256, 6257, 6258		
ICAILAN	308	N	Y	N	N	1	4095	1	Y	Y	NOCHECK, 6139, 6140		
ICASDL C	308	N	Y	N	N	1	4095	1	Y	Y	NOCHECK, 6251, 6252, 6253, 6254, 6255, 6256, 6257, 6258		
ICATELE2	308	N	Y	N	N	1	4095	1	Y	Y	NOCHECK, 6241, 6242, 6243, 6244, 6251, 6252, 6253, 6254, 6255, 6256, 6257, 6258		
IQD	314	N	Y	N	N	3	4095	10	N	N	IQD		
OSA	314	N	Y	N	N	1	4095	2	N	Y	OSA		
OSA-M	314	N	Y	N	N	1	4095	2	N	Y	OSA, OSM		
OSA-X	314	N	Y	N	N	1	4095	2	N	Y	OSA, OSX		
OSAD	314	N	Y	N	N	1	4095	1	N	Y	OSA, OSM, OSN, OSX		
OSN	314	N	Y	N	N	1	4095	1	N	N	OSN		
RS6K	312	N	Y	N	N	1	4095	1	N	Y	NOCHECK, RS6K, RS6K-2		
SCTC	270	N	Y	N	N	1	4095	1	N	Y	NOCHECK, SCTC		
SWCH	307	N	Y	N	N	1	4095	1	Y	Y	NOCHECK, SWCH, 2032, 9032, 9032-3, 9032-5, 9033		
TWX	281	N	Y	N	N	1	4095	1	Y	Y	NOCHECK, 2701, 3704, 3705, 3720, 3725, 3745, 3746		
WTTA	281	N	N	N	N	1	4095	1	Y	Y	NOCHECK, 2701, 3704, 3705, 3720, 3725, 3745, 3746		
1030	280	N	N	N	N	1	4095	1	Y	Y	NOCHECK, 2701, 3704, 3705, 3720, 3725, 3745, 3746		
1050	280	N	Y	N	N	1	4095	1	Y	Y	NOCHECK, 2701, 3704, 3705, 3720, 3725, 3745, 3746		
1050X	280	N	Y	N	N	1	4095	1	Y	Y	NOCHECK, 2701, 3704, 3705, 3720, 3725, 3745, 3746		
115A	280	N	N	N	N	1	4095	1	Y	Y	NOCHECK, 2701, 3704, 3705, 3720, 3725, 3745, 3746		
1287	288	N	Y	N	N	1	4095	1	Y	Y	NOCHECK, 1287		
1288	288	N	Y	N	N	1	4095	1	Y	Y	NOCHECK, 1288		
1403-N1	268	N	Y	N	N	1	4095	1	Y	Y	NOCHECK, 2821		
1403-2	268	N	Y	N	N	1	4095	1	Y	Y	NOCHECK, 2821		
1403-3	268	N	Y	N	N	1	4095	1	Y	Y	NOCHECK, 2821		
1403-5	268	N	Y	N	N	1	4095	1	Y	Y	NOCHECK, 2821		
1403-7	268	N	Y	N	N	1	4095	1	Y	Y	NOCHECK, 2821		
2032	307	N	Y	N	N	1	4095	1	Y	Y	NOCHECK, 2032		
2250-3	277	N	Y	N	N	1	4095	1	Y	Y	NOCHECK, 2840-2, 3258		
2305-2	269	N	Y	N	1	1	1	1	Y	Y	NOCHECK, 2835-2		
2501-B1	266	N	Y	N	N	1	4095	1	Y	Y	NOCHECK, 2501		
2501-B2	266	N	Y	N	N	1	4095	1	Y	Y	NOCHECK, 2501		
2540P-1	268	N	Y	N	N	1	4095	1	Y	Y	NOCHECK, 2821		
2540R-1	266	N	Y	N	N	1	4095	1	Y	Y	NOCHECK, 2821		
2701	279	N	Y	N	N	1	4095	1	Y	N	NOCHECK, 2701		
2710	278	N	Y	N	N	1	4095	1	Y	Y	AFP1, NOCHECK, 2710		
2740	280	N	Y	N	N	1	4095	1	Y	Y	NOCHECK, 2701, 3704, 3705, 3720, 3725, 3745, 3746		
2740C	280	N	Y	N	N	1	4095	1	Y	Y	NOCHECK, 2701, 3704, 3705, 3720, 3725, 3745, 3746		
2740X	280	N	Y	N	N	1	4095	1	Y	Y	NOCHECK, 2701, 3704, 3705, 3720, 3725, 3745, 3746		
2741C	281	N	Y	N	N	1	4095	1	Y	Y	NOCHECK, 2701, 3704, 3705, 3720, 3725, 3745, 3746		
2741P	281	N	Y	N	N	1	4095	1	Y	Y	NOCHECK, 2701, 3704, 3705, 3720, 3725, 3745, 3746		
3088	270	N	Y	N	N	1	4095	32	N	Y	NOCHECK, 3088		
3151	281	N	Y	N	N	1	4095	1	Y	Y	NOCHECK, 2701, 3174, 3272, 3274, 3704, 3705, 3720, 3791L, 6120		
3160	278	N	Y	N	N	1	4095	1	Y	Y	AFP1, NOCHECK, 3160		
3161	281	N	Y	N	N	1	4095	1	Y	Y	NOCHECK, 2701, 3704, 3705, 3720, 3725, 3745, 7171		
3162	281	N	Y	N	N	1	4095	1	Y	Y	NOCHECK, 2701, 3704, 3705, 3720, 3725, 3745, 7171		
3163	281	N	Y	N	N	1	4095	1	Y	Y	NOCHECK, 2701, 3704, 3705, 3720, 3725, 3745, 7171		
3167	281	N	Y	N	N	1	4095	1	Y	Y	NOCHECK, 2701, 3704, 3705, 3720, 3725, 3745		
3170	278	N	Y	N	N	1	4095	1	Y	Y	AFP1, NOCHECK, 3170		
3172	313	N	Y	N	N	1	4095	1	N	Y	NOCHECK, 3172		
3174	283	N	Y	N	N	1	4095	1	Y	N	NOCHECK, 3174, 3704, 3705, 3720, 3725, 3745, 3746, 6120		
3178	260	N	Y	N	N	1	4095	1	Y	Y	NOCHECK, 3174, 3272, 3274, 3791L, 6120		
3179	260	N	Y	N	N	1	4095	1	Y	Y	NOCHECK, 3174, 3272, 3274, 3791L, 6120		
3180	260	N	Y	N	N	1	4095	1	Y	Y	NOCHECK, 3174, 3272, 3274, 3791L, 6120		
3180-1	260	N	Y	N	N	1	4095	1	Y	Y	NOCHECK, 3174, 3272, 3274, 3791L, 6120		
3190	260	N	Y	N	N	1	4095	1	Y	Y	NOCHECK, 3174, 3272, 3274, 3791L, 6120		
3191	260	N	Y	N	N	1	4095	1	Y	Y	NOCHECK, 3174, 3272, 3274, 3791L, 6120		

Figure 70. Supported Hardware Report - Devices (Part 15 of 26)

TYPE-MODEL	UIM	MVS	VM	MX	GR	RL	RH	SUPPORTED HARDWARE - DEVICES			ATTACHABLE TO CU
								RD	TM	ST	
3192	260	N	Y	N	N	1	4095	1	Y	Y	NOCHECK,3174,3272,3274,3791L,6120
3192-F	260	N	Y	N	N	1	4095	1	Y	Y	NOCHECK,3174,3272,3274,3791L,6120
3193	260	N	Y	N	N	1	4095	1	Y	Y	NOCHECK,3174,3272,3274,3791L,6120
3194	260	N	Y	N	N	1	4095	1	Y	Y	NOCHECK,3174,3272,3274,3791L,6120
3203-4	268	N	N	N	N	1	4095	1	Y	Y	NOCHECK,3203
3203-5	268	N	Y	N	N	1	4095	1	Y	Y	NOCHECK,3203
3211	268	N	Y	N	N	1	4095	1	Y	Y	NOCHECK,3811
3215	260	N	Y	N	N	1	4095	1	Y	Y	NOCHECK,OSC
3216	278	N	Y	N	N	1	4095	1	Y	Y	NOCHECK,3811
3250	277	N	Y	N	N	1	4095	1	Y	Y	NOCHECK,3258
3251	277	N	Y	N	N	1	4095	1	Y	Y	NOCHECK,3258,5088-1,5088-2,6098
3262-13	287	N	Y	N	N	1	4095	1	Y	Y	NOCHECK,3174,3272,3274,3791L,4248,6120
3262-3	287	N	Y	N	N	1	4095	1	Y	Y	NOCHECK,3174,3272,3274,3791L,4248,6120
3262-5	268	N	Y	N	N	1	4095	1	Y	Y	NOCHECK,3174,3262,3272,3274,3791L,4248,6120
3268-2	287	N	Y	N	N	1	4095	1	Y	Y	NOCHECK,3174,3272,3274,3791L,6120
3270	260	N	Y	N	N	1	4095	1	Y	Y	NOCHECK,3174,3272,3274,3791L,6120
3270-X	260	N	Y	N	N	1	4095	1	Y	Y	NOCHECK,OSC,3174,3272,3274,3791L,6120
3272	283	N	N	N	N	1	4095	1	Y	N	NOCHECK,3272,3791L
3274	283	N	Y	N	N	1	4095	1	Y	N	NOCHECK,3272,3274,3704,3705,3720,3725,3745,3746
3277-1	260	N	Y	N	N	1	4095	1	Y	Y	NOCHECK,3272,3274,3791L,6120,7171
3277-2	260	N	Y	N	N	1	4095	1	Y	Y	NOCHECK,3272,3274,3791L,6120,7171
3278-1	260	N	Y	N	N	1	4095	1	Y	Y	NOCHECK,3174,3272,3274,3791L,6120,7171
3278-2	260	N	Y	N	N	1	4095	1	Y	Y	NOCHECK,3174,3272,3274,3791L,6120,7171
3278-2A	260	N	Y	N	N	1	4095	1	Y	Y	NOCHECK,3174,3272,3274,3791L,6120,7171
3278-3	260	N	Y	N	N	1	4095	1	Y	Y	NOCHECK,3174,3272,3274,3791L,6120,7171
3278-4	260	N	Y	N	N	1	4095	1	Y	Y	NOCHECK,3174,3272,3274,3791L,6120,7171
3278-5	260	N	Y	N	N	1	4095	1	Y	Y	NOCHECK,3174,3272,3274,3791L,6120,7171
3279-S2B	260	N	Y	N	N	1	4095	1	Y	Y	NOCHECK,3174,3272,3274,3791L,6120,7171
3279-S3G	260	N	Y	N	N	1	4095	1	Y	Y	NOCHECK,3174,3272,3274,3791L,6120,7171
3279-2	260	N	Y	N	N	1	4095	1	Y	Y	NOCHECK,3174,3272,3274,3791L,6120,7171
3279-2A	260	N	Y	N	N	1	4095	1	Y	Y	NOCHECK,3174,3272,3274,3791L,6120,7171
3279-2B	260	N	Y	N	N	1	4095	1	Y	Y	NOCHECK,3174,3272,3274,3791L,5088-1,5088-2,6098,6120,7171
3279-2C	260	N	Y	N	N	1	4095	1	Y	Y	NOCHECK,3174,3272,3274,3791L,6120,7171
3279-2X	260	N	Y	N	N	1	4095	1	Y	Y	NOCHECK,3174,3272,3274,3791L,6120,7171
3279-3	260	N	Y	N	N	1	4095	1	Y	Y	NOCHECK,3174,3272,3274,3791L,6120,7171
3279-3A	260	N	Y	N	N	1	4095	1	Y	Y	NOCHECK,3174,3272,3274,3791L,6120,7171
3279-3B	260	N	Y	N	N	1	4095	1	Y	Y	NOCHECK,3174,3272,3274,3791L,5088-1,5088-2,6098,6120,7171
3279-3X	260	N	Y	N	N	1	4095	1	Y	Y	NOCHECK,3174,3272,3274,3791L,6120,7171
3284-1	287	N	Y	N	N	1	4095	1	Y	Y	NOCHECK,3272,3274,3791L
3284-2	287	N	Y	N	N	1	4095	1	Y	Y	NOCHECK,3272,3274,3791L
3286-1	287	N	Y	N	N	1	4095	1	Y	Y	NOCHECK,3174,3272,3274,3791L,6120,7171
3286-2	287	N	Y	N	N	1	4095	1	Y	Y	NOCHECK,3174,3272,3274,3791L,6120,7171
3287-1	287	N	Y	N	N	1	4095	1	Y	Y	NOCHECK,OSC,3174,3272,3274,3791L,6120
3287-1C	287	N	Y	N	N	1	4095	1	Y	Y	NOCHECK,OSC,3174,3272,3274,3791L,6120
3287-2	287	N	Y	N	N	1	4095	1	Y	Y	NOCHECK,OSC,3174,3272,3274,3791L,6120
3287-2C	287	N	Y	N	N	1	4095	1	Y	Y	NOCHECK,OSC,3174,3272,3274,3791L,6120
3288	287	N	Y	N	N	1	4095	1	Y	Y	NOCHECK,3272,3274,3791L
3289-1	287	N	Y	N	N	1	4095	1	Y	Y	NOCHECK,3174,3272,3274,3791L,6120
3289-2	287	N	Y	N	N	1	4095	1	Y	Y	NOCHECK,3174,3272,3274,3791L,6120
3290	260	N	Y	N	N	1	4095	1	Y	Y	NOCHECK,3174,3272,3274,3791L,6120
3300	278	N	Y	N	N	1	4095	1	Y	Y	AFP1,NOCHECK,3300
3330-1	257	N	Y	N	N	1	4095	2	Y	Y	NOCHECK,3830-2,3880-1,3880-2
3330-11	257	N	Y	N	N	1	4095	2	Y	Y	NOCHECK,3830-2,3830-3,3880-1,3880-2
3330-2	257	N	Y	N	N	1	4095	2	Y	Y	NOCHECK,3830-2,3880-1,3880-2
3330V	271	N	Y	N	N	1	4095	1	Y	Y	NOCHECK,3830-3
3333-1	257	N	Y	N	N	1	4095	2	Y	Y	NOCHECK,3830-2,3880-1,3880-2
3333-11	257	N	Y	N	N	1	4095	2	Y	Y	NOCHECK,3830-2,3880-1,3880-2
3340	257	N	Y	N	N	1	4095	2	Y	Y	NOCHECK,3830-2,3880-1,3880-2
3344	257	N	Y	N	N	1	4095	2	Y	Y	NOCHECK,3830-2,3880-1
3350	257	N	Y	N	N	1	4095	2	Y	Y	NOCHECK,3830-2,3830-3,3880-1,3880-2
3370	258	N	Y	N	N	1	4095	1	Y	Y	NOCHECK,3880-1,3880-11,3880-2
3375	258	N	Y	N	N	1	4095	1	Y	Y	NOCHECK,3880-1,3880-11,3880-2,3880-4
3380	258	N	Y	N	N	1	4095	1	Y	Y	NOCHECK,1750,2105,2107,3380-CJ2,3880-13,3880-2,3880-23,3880-3,3990,3990-1,3990-2,3990-3,3990-6
3380-CJ2	258	N	Y	N	N	1	4095	1	Y	Y	NOCHECK,3380-CJ2,3880-13,3880-2,3880-23,3880-3,3990,3990-1,3990-2,3990-3,3990-6
3380A	258	N	Y	N	N	1	4095	1	Y	Y	NOCHECK,1750,2105,2107
3380B	258	N	Y	N	N	1	4095	1	Y	Y	NOCHECK,1750,2105,2107
3390	258	N	Y	N	N	1	4095	1	Y	Y	NOCHECK,1750,2105,2107,3990,3990-2,3990-3,3990-6
3390A	258	N	Y	N	N	1	4095	1	Y	Y	NOCHECK,1750,2105,2107
3390B	258	N	Y	N	N	1	4095	1	Y	Y	NOCHECK,1750,2105,2107
3420-3	261	N	Y	N	N	1	4095	1	Y	Y	NOCHECK,3803
3420-4	261	N	Y	N	N	1	4095	1	Y	Y	NOCHECK,3803

Figure 71. Supported Hardware Report - Devices (Part 16 of 26)

TYPE-MODEL	UIM	MVS	VM	MX	GR	RL	RH	SUPPORTED HARDWARE - DEVICES			ATTACHABLE TO CU
								RD	TM	ST	
3420-5	261	N	Y	N	N	1	4095	1	Y	Y	NOCHECK, 3803
3420-6	261	N	Y	N	N	1	4095	1	Y	Y	NOCHECK, 3803
3420-7	261	N	Y	N	N	1	4095	1	Y	Y	NOCHECK, 3803
3420-8	261	N	Y	N	N	1	4095	1	Y	Y	NOCHECK, 3803
3422	261	N	Y	N	N	1	4095	1	Y	Y	NOCHECK, 3422
3423	261	N	N	N	N	1	4095	1	Y	Y	NOCHECK, 3423
3424	261	N	Y	N	N	1	4095	1	Y	Y	NOCHECK, 3424
3430	261	N	Y	N	N	1	4095	1	Y	Y	NOCHECK, 3430
3471	260	N	N	N	N	1	4095	1	Y	Y	NOCHECK, 3174, 3274
3472	260	N	N	N	N	1	4095	1	Y	Y	NOCHECK, 3174, 3274
3480	261	N	Y	N	N	1	4095	1	Y	Y	NOCHECK, 3480
3481	260	N	N	N	N	1	4095	1	Y	Y	NOCHECK, 3174, 3274
3482	260	N	N	N	N	1	4095	1	Y	Y	NOCHECK, 3174, 3274
3483	260	N	N	N	N	1	4095	1	Y	Y	NOCHECK, 3174, 3274
3490	261	N	Y	N	N	1	4095	1	Y	Y	NOCHECK, 3490, 3490-C1A, 3490-C10, 3490-C11, 3490-C2A, 3490-C22
3505	266	N	Y	N	N	1	4095	1	Y	Y	NOCHECK, 3505
3525	268	N	Y	N	N	1	4095	1	Y	Y	NOCHECK, 3505
3540	288	N	Y	N	N	1	4095	1	Y	Y	NOCHECK, 3540
3590	261	N	Y	N	N	1	4095	1	Y	Y	NOCHECK, 3590
3704	279	N	Y	N	N	1	4095	1	Y	N	NOCHECK, 3704
3705	279	N	Y	N	N	1	4095	1	Y	N	NOCHECK, 3705
3720	279	N	Y	N	N	1	4095	1	Y	N	NOCHECK, 3720
3725	279	N	Y	N	N	1	4095	1	Y	N	NOCHECK, 3725
3737	270	N	Y	N	N	1	4095	1	N	Y	NOCHECK, 3737
3745	279	N	Y	N	N	1	4095	1	Y	N	NOCHECK, OSN, 3745, 3746
3746	279	N	Y	N	N	1	4095	1	Y	N	NOCHECK
3767-1	280	N	N	N	N	1	4095	1	Y	Y	NOCHECK, 2701, 3704, 3705, 3720, 3725, 3745, 3746
3767-2	280	N	N	N	N	1	4095	1	Y	Y	NOCHECK, 2701, 3704, 3705, 3720, 3725, 3745, 3746
3791L	283	N	N	N	N	1	4095	1	Y	N	NOCHECK, 3174, 3272, 3274, 3704, 3705, 3720, 3725, 3745, 3746, 3791L, 7171
3800-1	267	N	Y	N	N	1	4095	1	Y	Y	NOCHECK, 3800-1
3800-3	267	N	Y	N	N	1	4095	1	Y	Y	NOCHECK, 3800-3
3800-6	267	N	Y	N	N	1	4095	1	Y	Y	NOCHECK, 3800-6
3800-8	267	N	Y	N	N	1	4095	1	Y	Y	NOCHECK, 3800-8
3812	287	N	Y	N	N	1	4095	1	Y	Y	NOCHECK, 3174, 3272, 3274, 3791L, 6120
3816	287	N	Y	N	N	1	4095	1	Y	Y	NOCHECK, 3174, 3272, 3274, 3791L, 6120
3820	278	N	Y	N	N	1	4095	1	Y	N	NOCHECK, 3820
3825	278	N	Y	N	N	1	4095	1	Y	Y	AFP1, NOCHECK, 3825
3827	278	N	Y	N	N	1	4095	1	Y	Y	AFP1, NOCHECK, 3827
3828	278	N	Y	N	N	1	4095	1	Y	Y	AFP1, NOCHECK, 3828
3829	278	N	Y	N	N	1	4095	1	Y	Y	AFP1, NOCHECK, 3829
3831	278	N	Y	N	N	1	4095	1	Y	Y	AFP1, NOCHECK, 3831
3835	278	N	Y	N	N	1	4095	1	Y	Y	AFP1, NOCHECK, 3835
3851	271	N	Y	N	N	1	4095	1	Y	Y	NOCHECK, 3851
3886	288	N	Y	N	N	1	4095	1	Y	Y	NOCHECK, 3886
3890	288	N	Y	N	N	1	4095	1	Y	Y	NOCHECK, 3890
3895	288	N	Y	N	N	1	4095	1	Y	Y	NOCHECK, 3895
3900	278	N	Y	N	N	1	4095	1	Y	Y	AFP1, NOCHECK, 3900
3935	278	N	Y	N	N	1	4095	1	Y	Y	AFP1, NOCHECK, 3935
3995	309	N	Y	N	Y	1	1	1	N	Y	NOCHECK, 3995, 3995-SDA
3995-SDA	309	N	Y	N	N	1	256	16	N	Y	NOCHECK, 3995-SDA
3995-151	258	N	Y	N	N	1	4095	1	Y	Y	NOCHECK, 3995-151
3995-153	258	N	Y	N	N	1	4095	1	Y	Y	NOCHECK, 3995-153
4000	278	N	Y	N	N	1	4095	1	Y	Y	AFP1, NOCHECK, 4000
4224	287	N	Y	N	N	1	4095	1	Y	Y	NOCHECK, 3174, 3272, 3274, 3791L, 6120
4245	268	N	Y	N	N	1	4095	1	Y	Y	NOCHECK, 4245, 6120
4248	268	N	Y	N	N	1	4095	1	Y	Y	NOCHECK, 4248
4250	287	N	N	N	N	1	4095	1	Y	Y	NOCHECK, 3174, 3272, 3274, 3791L, 6120
4370	278	N	Y	N	N	1	4095	1	Y	Y	AFP1, NOCHECK, 4370
5080	291	N	Y	N	N	1	4095	1	Y	Y	NOCHECK, 5088-1, 5088-2, 6098
5081	291	N	Y	N	N	1	4095	1	Y	Y	NOCHECK, 5088-1, 5088-2, 6098
5210	287	N	Y	N	N	1	4095	1	Y	Y	NOCHECK, 3174, 3272, 3274, 3791L, 6120
6090	291	N	Y	N	N	1	4095	1	Y	Y	NOCHECK, 5088-1, 5088-2, 6098
6091	291	N	Y	N	N	1	4095	1	Y	Y	NOCHECK, 5088-1, 5088-2, 6098
6262	268	N	Y	N	N	1	4095	1	Y	Y	NOCHECK, 4248, 6262
7171	283	N	Y	N	N	1	4095	1	Y	N	NOCHECK, 7171
7770-3	279	N	N	N	N	1	4095	1	Y	N	NOCHECK, 7770-3
8232	270	N	Y	N	N	1	4095	32	N	Y	NOCHECK, 8232
8383	281	N	N	N	N	1	4095	1	Y	Y	NOCHECK, 2701, 3704, 3705, 3720, 3725, 3745, 3746
9032	307	N	Y	N	N	1	4095	1	Y	Y	NOCHECK, 9032
9032-3	307	N	Y	N	N	1	4095	1	Y	Y	NOCHECK, 9032, 9032-3
9032-5	307	N	Y	N	N	1	4095	1	Y	Y	NOCHECK, 9032, 9032-5
9033	307	N	Y	N	N	1	4095	1	Y	Y	NOCHECK, 9033

Figure 72. Supported Hardware Report - Devices (Part 17 of 26)

---

SUPPORTED HARDWARE - DEVICES											TIME: 11:16	DATE: 2015-11-24	PAGE X- 18	
TYPE-MODEL	UIM	MVS	VM	MX	GR	RL	RH	RD	TM	ST	ATTACHABLE TO CU			
9332-40	258	N	Y	N	N	1	4095	1	Y	Y	NOCHECK,6310			
9332-42	258	N	Y	N	N	1	4095	1	Y	Y	NOCHECK,6310			
9332-60	258	N	Y	N	N	1	4095	1	Y	Y	NOCHECK,6310			
9332-62	258	N	Y	N	N	1	4095	1	Y	Y	NOCHECK,6310			
9335-B1	258	N	Y	N	N	1	4095	1	Y	Y	NOCHECK,6310			
9336-10	258	N	Y	N	N	1	4095	1	Y	Y	NOCHECK,6310			
9336-20	258	N	Y	N	N	1	4095	1	Y	Y	NOCHECK,6310			
9345	258	N	Y	N	N	1	4095	1	Y	Y	NOCHECK,9340,9341,9343,9343-1			
9348-1	261	N	Y	N	N	1	4095	1	Y	Y	NOCHECK,6311			

---

Figure 73. Supported Hardware Report - Devices (Part 18 of 26)

---

SUPPORTED HARDWARE - DEVICES		TIME: 11:16	DATE: 2015-11-24	PAGE X- 19
KEY	KEY DESCRIPTION			
---	-----			
TYPE-MODEL	- SUPPORTED DEVICE TYPE			
UIM	- INDEX OF UNIT INFORMATION MODULE SUPPORTING THIS DEVICE TYPE			
MVS	- DEVICE IS SUPPORTED FOR MVS DEFINITION			
VM	- DEVICE TYPE IS SUPPORTED FOR VM DEFINITION			
MX	- DEVICE IS A MULTI-EXPOSURE DEVICE OR A PARALLEL ACCESS VOLUME DEVICE			
GR	- DEVICE IS A GROUP DEVICE			
RL	- MINIMUM NUMBER OF DEVICES TO BE DEFINED			
RH	- MAXIMUM NUMBER OF DEVICES TO BE DEFINED			
RD	- DEFAULT NUMBER OF DEVICES TO BE DEFINED			
TM	- DEFAULT TIMEOUT VALUE			
ST	- DEFAULT STADET VALUE			
ATTACHABLE TO CU	- LIST OF CONTROL UNIT TYPES TO WHICH DEVICE TYPE IS ATTACHABLE			
Y	- DEVICE TYPE HAS THE CAPABILITY			
N	- CAPABILITY IS NOT AVAILABLE			

---

Figure 74. Supported Hardware Report - Devices (Part 19 of 26)

			SUPPORTED HARDWARE - VM DEVICES	TIME: 11:16 DATE: 2015-11-24 PAGE X- 22
TYPE-MODEL	UIM VM D/T	CONS	SUPPORTED PARAMETERS (VALUES) / FEATURES	
AFP1-0	278 AFP1	N	OFFLINE,UIRATE,EQID	
BCTC	270 CTCA	N	OFFLINE,UIRATE,EQID	
BSC1	282 3705	N	(R)ADAPTER(BSCA),BASEADD,OFFLINE,SETADDR(0,1,2,3,4),UIRATE,EQID	
BSC2	282 3705	N	(R)ADAPTER(BSCA),BASEADD,OFFLINE,SETADDR(0,1,2,3,4),UIRATE,EQID	
BSC3	282 3705	N	(R)ADAPTER(BSCA),BASEADD,OFFLINE,SETADDR(0,1,2,3,4),UIRATE,EQID	
CTC	270 CTCA	N	OFFLINE,UIRATE,EQID	
CTCA	270 CTCA	N	OFFLINE,UIRATE,EQID	
DUMMY	306 DUMMY	N	(R)CLASS(DASD,TAPE,TERM,DISPLAY,RDR,PRT,PUN,SWITCH),OFFLINE,UIRATE,EQID / DPS,RESERVE	
FBASCSI	254 FBASCSI	N	OFFLINE,UIRATE,EQID,(R)ATTR(1750,2105,2107,2145,XIV,SCSI),(R)FCPDEV,(R)WWPN,(R)LUN,PREFPATH	
FB512	258 FB-512	N	OFFLINE,SHARED,UIRATE,MDC(OFF,DFLTOFF,DFLTON),EQID	
FCP	254 FCP	N	OFFLINE,UIRATE,EQID	
FCTC	270 CTCA	N	OFFLINE,UIRATE,EQID	
HFGD	291 HFGD	N	OFFLINE,UIRATE,EQID	
ICABSCA	308 ICA	N	(R)ADAPTER(BSCA),OFFLINE,UIRATE,EQID	
ICAEAN	308 ICA	N	(R)ADAPTER(ELAN),OFFLINE,UIRATE,EQID	
ICAHDL	308 ICA	N	(R)ADAPTER(HDLC),OFFLINE,UIRATE,EQID	
ICAILAN	308 ICA	N	(R)ADAPTER(ILAN),OFFLINE,UIRATE,EQID	
ICASDL	308 ICA	N	(R)ADAPTER(SDLC),OFFLINE,UIRATE,EQID	
ICATELE2	308 ICA	N	(R)ADAPTER(TELE2),OFFLINE,UIRATE,EQID	
IQD	314 OSA	N	OFFLINE,UIRATE,EQID	
OSA	314 OSA	N	OFFLINE,UIRATE,EQID	
OSA-M	314 OSA	N	OFFLINE,UIRATE,EQID	
OSA-X	314 OSA	N	OFFLINE,UIRATE,EQID	
OSAD	314 OSAD	N	OFFLINE,UIRATE,EQID	
OSN	314 OSN	N	OFFLINE,UIRATE,EQID	
RS6K	312 3088	N	OFFLINE,UIRATE,EQID	
SCTC	270 CTCA	N	OFFLINE,UIRATE,EQID	
SWCH	307 9032	N	OFFLINE,UIRATE,EQID	
TWX	281 3705	N	(R)ADAPTER(TELE2),BASEADD,OFFLINE,SETADDR(0,1,2,3,4),UIRATE,EQID	
1050	280 3705	N	(R)ADAPTER(IBM1),BASEADD,OFFLINE,SETADDR(0,1,2,3,4),UIRATE,EQID	
1050X	280 3705	N	(R)ADAPTER(IBM1),BASEADD,OFFLINE,SETADDR(0,1,2,3,4),UIRATE,EQID	
1287	288 1287	N	OFFLINE,UIRATE,EQID	
1288	288 1288	N	OFFLINE,UIRATE,EQID	
1403-N1	268 1403	N	AFP,CHARS,CLASS,DEST,FOLD,FORM,IMAGE,OFFLINE,SEP,UIRATE,EQID / UNVCHSET	
1403-2	268 1403	N	AFP,CHARS,CLASS,DEST,FOLD,FORM,IMAGE,OFFLINE,SEP,UIRATE,EQID / UNVCHSET	
1403-3	268 1403	N	AFP,CHARS,CLASS,DEST,FOLD,FORM,IMAGE,OFFLINE,SEP,UIRATE,EQID / UNVCHSET	
1403-5	268 1403	N	AFP,CHARS,CLASS,DEST,FOLD,FORM,IMAGE,OFFLINE,SEP,UIRATE,EQID / UNVCHSET	
1403-7	268 1403	N	AFP,CHARS,CLASS,DEST,FOLD,FORM,IMAGE,OFFLINE,SEP,UIRATE,EQID / UNVCHSET	
2032	307 2032	N	OFFLINE,UIRATE,EQID	
2250-3	277 2250	N	OFFLINE,UIRATE,EQID	
2305-2	269 2305-2	N	OFFLINE,SHARED,UIRATE,EQID	
2501-B1	266 2501	N	CLASS,OFFLINE,UIRATE,EQID	
2501-B2	266 2501	N	CLASS,OFFLINE,UIRATE,EQID	
2540P-1	268 2540P	N	CLASS,FORM,OFFLINE,SEP,UIRATE,EQID	
2540R-1	266 2540R	N	CLASS,OFFLINE,UIRATE,EQID	
2701	279 2701	N	(R)ADAPTER(BSCA,IBM1,TELE2),OFFLINE,UIRATE,EQID	
2710	278 AFP1	N	OFFLINE,UIRATE,EQID	
2740	280 3705	N	(R)ADAPTER(IBM1),BASEADD,OFFLINE,SETADDR(0,1,2,3,4),UIRATE,EQID	
2740C	280 3705	N	(R)ADAPTER(IBM1),BASEADD,OFFLINE,SETADDR(0,1,2,3,4),UIRATE,EQID	
2740X	280 3705	N	(R)ADAPTER(IBM1),BASEADD,OFFLINE,SETADDR(0,1,2,3,4),UIRATE,EQID	
2741C	281 3705	N	(R)ADAPTER(IBM1),BASEADD,OFFLINE,SETADDR(0,1,2,3,4),UIRATE,EQID	
2741P	281 3705	N	(R)ADAPTER(IBM1),BASEADD,OFFLINE,SETADDR(0,1,2,3,4),UIRATE,EQID	
3088	270 3088	N	OFFLINE,UIRATE,EQID	
3151	281 3705	N	(R)ADAPTER(TELE2),BASEADD,OFFLINE,SETADDR(0,1,2,3,4),UIRATE,EQID	
3160	278 AFP1	N	OFFLINE,UIRATE,EQID	
3161	281 3705	N	(R)ADAPTER(TELE2),BASEADD,OFFLINE,SETADDR(0,1,2,3,4),UIRATE,EQID	
3162	281 3705	N	(R)ADAPTER(TELE2),BASEADD,OFFLINE,SETADDR(0,1,2,3,4),UIRATE,EQID	
3163	281 3705	N	(R)ADAPTER(TELE2),BASEADD,OFFLINE,SETADDR(0,1,2,3,4),UIRATE,EQID	
3167	281 3705	N	(R)ADAPTER(TELE2),BASEADD,OFFLINE,SETADDR(0,1,2,3,4),UIRATE,EQID	
3170	278 AFP1	N	OFFLINE,UIRATE,EQID	
3172	313 3172	N	OFFLINE,UIRATE,EQID	
3174	283 3705	N	(R)ADAPTER(TYPE4),CPNAME,(R)MODEL(A1,A2,B1,B2,B3,B4,C1,C2,C3,C4,C5,C6,D1,D2,D3,D4,D5,D6,D7,D8,E1,E2,E3,E4,E5,E6,E7,E8,F1,F2,F3,F4,F5,F6,F7,F8,G1,G2,G3,G4,G5,G6,G7,G8,H1,H2,H3,H4,H5,H6,H7,H8,J1,J2,J3,J4,K1,K2,K3,K4,L1,L2,L3,L4,1,2,3,4,5,6,7,8),OFFLINE,UIRATE,EQID	
3178	260 3178	Y	MODEL(2,3,4,5),OFFLINE,UIRATE,EQID / EMUL3270,E3270HLD,OPRDR	
3179	260 3179	Y	MODEL(2,3),OFFLINE,UIRATE,EQID / EMUL3270,E3270HLD,OPRDR	
3180	260 3180	Y	MODEL(2,3,4,5),OFFLINE,UIRATE,EQID / EMUL3270,E3270HLD,OPRDR	
3180-1	260 3180	Y	OFFLINE,UIRATE,EQID / EMUL3270,E3270HLD,OPRDR	
3190	260 3190	Y	OFFLINE,UIRATE,EQID / EMUL3270,E3270HLD,OPRDR	
3191	260 3190	Y	OFFLINE,UIRATE,EQID / EMUL3270,E3270HLD,OPRDR	
3192	260 3190	Y	OFFLINE,UIRATE,EQID / EMUL3270,E3270HLD,OPRDR	

Figure 75. Supported Hardware Report - VM Devices (Part 20 of 24)

TYPE-MODEL	UIM VM D/T	CONS	SUPPORTED PARAMETERS (VALUES) / FEATURES
3192-F	260 3190	Y	OFFLINE,UIRATE,EQID / EMUL3270,E3270HLD,OPRDR
3193	260 3190	Y	OFFLINE,UIRATE,EQID / EMUL3270,E3270HLD,OPRDR
3194	260 3190	Y	OFFLINE,UIRATE,EQID / EMUL3270,E3270HLD,OPRDR
3203-5	268 3203-5	N	APP,CHARS,CLASS,DEST,FCB,FOLD,FORM,IMAGE,OFFLINE,SEP,UIRATE,LIMIT,EQID / UNVCHSET
3211	268 3211	N	APP,CHARS,CLASS,DEST,FCB,FOLD,FORM,IMAGE,INDEX,OFFLINE,SEP,UIRATE,LIMIT,EQID / UNVCHSET
3215	260 3215	Y	OFFLINE,UIRATE,EQID
3216	278 AFP1	N	OFFLINE,UIRATE,EQID
3250	277 3250	N	OFFLINE,UIRATE,EQID
3251	277 3250	N	OFFLINE,UIRATE,EQID
3262-13	287 3287	N	OFFLINE,UIRATE,EQID
3262-3	287 3287	N	OFFLINE,UIRATE,EQID
3262-5	268 3262	N	APP,CHARS,CLASS,DEST,FCB,FOLD,FORM,IMAGE,OFFLINE,SEP,UIRATE,LIMIT,EQID
3268-2	287 3287	N	OFFLINE,UIRATE,EQID
3270	260 3270	Y	MODEL(2A,2C,2,3,4,5),OFFLINE,UIRATE,EQID / EMUL3270,E3270HLD,OPRDR
3270-X	260 3270	Y	OFFLINE,UIRATE,EQID / EMUL3270,E3270HLD,OPRDR
3274	283 3705	N	(R)ADAPTER(TYPE4),CPNAME,(R)MODEL(A1,A2,B1,B2,B3,B4,C1,C2,C3,C4,C5,C6,D1,D2,D3,D4,D5,D6,D7,D8,E1,E2,E3,E4,E5,E6,E7,E8,F1,F2,F3,F4,F5,F6,F7,F8,G1,G2,G3,G4,G5,G6,G7,G8,H1,H2,H3,H4,H5,H6,H7,H8,J1,J2,J3,J4,K1,K2,K3,K4,L1,L2,L3,L4,1,2,3,4,5,6,7,8),OFFLINE,UIRATE,EQID
3277-1	260 3277	Y	OFFLINE,UIRATE,EQID / EMUL3270,E3270HLD,OPRDR
3277-2	260 3277	Y	OFFLINE,UIRATE,EQID / EMUL3270,E3270HLD,OPRDR
3278-1	260 3278	Y	OFFLINE,UIRATE,EQID / EMUL3270,E3270HLD,OPRDR
3278-2	260 3278	Y	OFFLINE,UIRATE,EQID / EMUL3270,E3270HLD,OPRDR
3278-2A	260 3278-2A	Y	OFFLINE,UIRATE,EQID / EMUL3270,E3270HLD,OPRDR
3278-3	260 3278-3	Y	OFFLINE,UIRATE,EQID / EMUL3270,E3270HLD,OPRDR
3278-4	260 3278-4	Y	OFFLINE,UIRATE,EQID / EMUL3270,E3270HLD,OPRDR
3278-5	260 3278-5	Y	OFFLINE,UIRATE,EQID / EMUL3270,E3270HLD,OPRDR
3279-S2B	260 3279	Y	OFFLINE,UIRATE,EQID / EMUL3270,E3270HLD,OPRDR
3279-S3G	260 3279	Y	OFFLINE,UIRATE,EQID / EMUL3270,E3270HLD,OPRDR
3279-2	260 3279	Y	OFFLINE,UIRATE,EQID / EMUL3270,E3270HLD,OPRDR
3279-2A	260 3279	Y	OFFLINE,UIRATE,EQID / EMUL3270,E3270HLD,OPRDR
3279-2B	260 3279	Y	OFFLINE,UIRATE,EQID / EMUL3270,E3270HLD,OPRDR
3279-2C	260 3279-2C	Y	OFFLINE,UIRATE,EQID / EMUL3270,E3270HLD,OPRDR
3279-2X	260 3279	Y	OFFLINE,UIRATE,EQID / EMUL3270,E3270HLD,OPRDR
3279-3	260 3279-3	Y	OFFLINE,UIRATE,EQID / EMUL3270,E3270HLD,OPRDR
3279-3A	260 3279	Y	OFFLINE,UIRATE,EQID / EMUL3270,E3270HLD,OPRDR
3279-3B	260 3279	Y	OFFLINE,UIRATE,EQID / EMUL3270,E3270HLD,OPRDR
3279-3X	260 3279	Y	OFFLINE,UIRATE,EQID / EMUL3270,E3270HLD,OPRDR
3284-1	287 3284	N	OFFLINE,UIRATE,EQID
3284-2	287 3284	N	OFFLINE,UIRATE,EQID
3286-1	287 3286	N	OFFLINE,UIRATE,EQID
3286-2	287 3286	N	OFFLINE,UIRATE,EQID
3287-1	287 3287	N	OFFLINE,UIRATE,EQID
3287-1C	287 3287	N	OFFLINE,UIRATE,EQID
3287-2	287 3287	N	OFFLINE,UIRATE,EQID
3287-2C	287 3287	N	OFFLINE,UIRATE,EQID
3288	287 3288	N	OFFLINE,UIRATE,EQID
3289-1	287 3289	N	OFFLINE,UIRATE,EQID
3289-2	287 3289	N	OFFLINE,UIRATE,EQID
3290	260 3290	Y	OFFLINE,UIRATE,EQID / EMUL3270,E3270HLD,OPRDR
3300	278 AFP1	N	OFFLINE,UIRATE,EQID
3330-1	257 3330-1	N	OFFLINE,SHARED,UIRATE,EQID
3330-11	257 3330-11	N	OFFLINE,SHARED,UIRATE,EQID
3330-2	257 3330-2	N	OFFLINE,SHARED,UIRATE,EQID
3330V	271 3330	N	OFFLINE,SHARED,UIRATE,EQID
3333-1	257 3330-1	N	OFFLINE,SHARED,UIRATE,EQID
3333-11	257 3330-11	N	OFFLINE,SHARED,UIRATE,EQID
3340	257 3340	N	OFFLINE,SHARED,UIRATE,EQID
3344	257 3340	N	OFFLINE,SHARED,UIRATE,EQID
3350	257 3350	N	OFFLINE,SHARED,UIRATE,EQID
3370	258 3370	N	OFFLINE,SHARED,UIRATE,MDC(OFF,DFLTOFF,DFLTON),EQID
3375	258 3375	N	OFFLINE,SHARED,UIRATE,MDC(OFF,DFLTOFF,DFLTON),EQID
3380	258 3380	N	OFFLINE,SHARED,UIRATE,MDC(OFF,DFLTOFF,DFLTON),EQID
3380-CJ2	258 3380	N	OFFLINE,SHARED,UIRATE,MDC(OFF,DFLTOFF,DFLTON),EQID
3380A	258 3380A	N	
3380B	258 3380B	N	OFFLINE,SHARED,UIRATE,MDC(OFF,DFLTOFF,DFLTON),EQID
3390	258 3390	N	OFFLINE,SHARED,UIRATE,MDC(OFF,DFLTOFF,DFLTON),EQID
3390A	258 3390A	N	
3390B	258 3390B	N	OFFLINE,SHARED,UIRATE,MDC(OFF,DFLTOFF,DFLTON),EQID
3420-3	261 3420-3	N	OFFLINE,UIRATE,EQID / CONV,DUALDENS,TRANS,7-TRACK
3420-4	261 3420-4	N	OFFLINE,UIRATE,EQID / CONV,DUALDENS,TRANS,7-TRACK
3420-5	261 3420-5	N	OFFLINE,UIRATE,EQID / CONV,DUALDENS,TRANS,7-TRACK
3420-6	261 3420-6	N	OFFLINE,UIRATE,EQID / CONV,DUALDENS,TRANS,7-TRACK

Figure 76. Supported Hardware Report - VM Devices (Part 21 of 24)

			SUPPORTED HARDWARE - VM DEVICES	TIME: 11:16 DATE: 2015-11-24 PAGE X- 24
TYPE-MODEL	UIM VM D/T	CONS	SUPPORTED PARAMETERS (VALUES) / FEATURES	
3420-7	261 3420-7	N	OFFLINE,UIRATE,EQID / CONV,DUALDENS,TRANS,7-TRACK	
3420-8	261 3420-8	N	OFFLINE,UIRATE,EQID / CONV,DUALDENS,TRANS,7-TRACK	
3422	261 3422	N	OFFLINE,UIRATE,EQID	
3424	261 3424	N	OFFLINE,UIRATE,EQID	
3430	261 3430	N	OFFLINE,UIRATE,EQID	
3480	261 3480	N	OFFLINE,UIRATE,EQID	
3490	261 3490	N	OFFLINE,UIRATE,EQID	
3505	266 3505	N	CLASS,OFFLINE,UIRATE,EQID	
3525	268 3525	N	CLASS,FORM,OFFLINE,UIRATE,EQID	
3540	288 3540	N	OFFLINE,UIRATE,EQID	
3590	261 3590	N	OFFLINE,UIRATE,EQID	
3704	279 3704	N	(R)ADAPTER(BSCA,IBM1,TELE2,TYPE1),BASEADD,CPNAME,MODEL(A1,A2,A3,A4,1,2,3,4),OFFLINE,SETADDR(0,1,2,3,4),UIRATE,EQID	
3705	279 3705	N	(R)ADAPTER(BSCA,IBM1,TELE2,TYPE4),BASEADD,CPNAME,MODEL(A1,A2,B1,B2,B3,B4,C1,C2,C3,C4,C5,C6,D1,D2,D3,D4,D5,D6,D7,D8,E1,E2,E3,E4,E5,E6,E7,E8,F1,F2,F3,F4,F5,F6,F7,F8,G1,G2,G3,G4,G5,G6,G7,G8,H1,H2,H3,H4,H5,H6,H7,H8,J1,J2,J3,J4,K1,K2,K3,K4,L1,L2,L3,L4,1,2,3,4,5,6,7,8),OFFLINE,SETADDR(0,1,2,3,4),UIRATE,EQID	
3720	279 3705	N	(R)ADAPTER(TYPE4),CPNAME,(R)MODEL(A1,A2,B1,B2,B3,B4,C1,C2,C3,C4,C5,C6,D1,D2,D3,D4,D5,D6,D7,D8,E1,E2,E3,E4,E5,E6,E7,E8,F1,F2,F3,F4,F5,F6,F7,F8,G1,G2,G3,G4,G5,G6,G7,G8,H1,H2,H3,H4,H5,H6,H7,H8,J1,J2,J3,J4,K1,K2,K3,K4,L1,L2,L3,L4,1,2,3,4,5,6,7,8),OFFLINE,UIRATE,EQID	
3725	279 3705	N	(R)ADAPTER(BSCA,IBM1,TELE2,TYPE4),BASEADD,CPNAME,MODEL(A1,A2,B1,B2,B3,B4,C1,C2,C3,C4,C5,C6,D1,D2,D3,D4,D5,D6,D7,D8,E1,E2,E3,E4,E5,E6,E7,E8,F1,F2,F3,F4,F5,F6,F7,F8,G1,G2,G3,G4,G5,G6,G7,G8,H1,H2,H3,H4,H5,H6,H7,H8,J1,J2,J3,J4,K1,K2,K3,K4,L1,L2,L3,L4,1,2,3,4,5,6,7,8),OFFLINE,SETADDR(0,1,2,3,4),UIRATE,EQID	
3737	270 CTCA	N	OFFLINE,UIRATE,EQID	
3745	279 3705	N	(R)ADAPTER(BSCA,IBM1,TELE2,TYPE4),BASEADD,CPNAME,MODEL(A1,A2,B1,B2,B3,B4,C1,C2,C3,C4,C5,C6,D1,D2,D3,D4,D5,D6,D7,D8,E1,E2,E3,E4,E5,E6,E7,E8,F1,F2,F3,F4,F5,F6,F7,F8,G1,G2,G3,G4,G5,G6,G7,G8,H1,H2,H3,H4,H5,H6,H7,H8,J1,J2,J3,J4,K1,K2,K3,K4,L1,L2,L3,L4,1,2,3,4,5,6,7,8),OFFLINE,SETADDR(0,1,2,3,4),UIRATE,EQID	
3746	279 3705	N	(R)ADAPTER(BSCA,IBM1,TELE2,TYPE4),BASEADD,CPNAME,MODEL(A1,A2,B1,B2,B3,B4,C1,C2,C3,C4,C5,C6,D1,D2,D3,D4,D5,D6,D7,D8,E1,E2,E3,E4,E5,E6,E7,E8,F1,F2,F3,F4,F5,F6,F7,F8,G1,G2,G3,G4,G5,G6,G7,G8,H1,H2,H3,H4,H5,H6,H7,H8,J1,J2,J3,J4,K1,K2,K3,K4,L1,L2,L3,L4,1,2,3,4,5,6,7,8),OFFLINE,SETADDR(0,1,2,3,4),UIRATE,EQID	
3800-1	267 3800	N	APP,CHARS,CLASS,DEST,DPMSIZE(1,2,3,4,5,6,7,8,9),FCB,FLASH,FORM,IMAGE,OFFLINE,SEP,UIRATE,MARK,LIMIT,EQID / 4WCGMS	
3800-3	267 3800-3	N	APP,CHARS,CLASS,DEST,DPMSIZE(1,2,3,4,5,6,7,8,9),FCB,FLASH,FORM,IMAGE,OFFLINE,SEP,UIRATE,MARK,LIMIT,EQID / 4WCGMS	
3800-6	267 3800-6	N	APP,CHARS,CLASS,DEST,DPMSIZE(1,2,3,4,5,6,7,8,9),FCB,FLASH,FORM,IMAGE,OFFLINE,SEP,UIRATE,MARK,LIMIT,EQID / 4WCGMS	
3800-8	267 3800-8	N	APP,OFFLINE,UIRATE,EQID / 4WCGMS	
3812	287 3287	N	OFFLINE,UIRATE,EQID	
3816	287 3287	N	OFFLINE,UIRATE,EQID	
3820	278 3820	N	OFFLINE,UIRATE,EQID	
3825	278 AFP1	N	OFFLINE,UIRATE,EQID	
3827	278 AFP1	N	OFFLINE,UIRATE,EQID	
3828	278 AFP1	N	OFFLINE,UIRATE,EQID	
3829	278 AFP1	N	OFFLINE,UIRATE,EQID	
3831	278 AFP1	N	OFFLINE,UIRATE,EQID	
3835	278 AFP1	N	OFFLINE,UIRATE,EQID	
3851	271 3851	N	OFFLINE,SHARED,UIRATE,EQID	
3886	288 3886	N	OFFLINE,UIRATE,EQID	
3890	288 3890	N	OFFLINE,UIRATE,EQID	
3895	288 3895	N	OFFLINE,UIRATE,EQID	
3900	278 AFP1	N	OFFLINE,UIRATE,EQID	
3935	278 AFP1	N	OFFLINE,UIRATE,EQID	
3995	309 3088	N	OFFLINE,UIRATE,EQID	
3995-SDA	309 3088	N	OFFLINE,UIRATE,EQID	
3995-151	258 3390	N	OFFLINE,SHARED,UIRATE,MDC(OFF,DFLTOFF,DFLTON),EQID	
3995-153	258 3390	N	OFFLINE,SHARED,UIRATE,MDC(OFF,DFLTOFF,DFLTON),EQID	
4000	278 AFP1	N	OFFLINE,UIRATE,EQID	
4224	287 3287	N	OFFLINE,UIRATE,EQID	
4245	268 4245	N	APP,CHARS,CLASS,DEST,FCB,FOLD,FORM,IMAGE,OFFLINE,SEP,UIRATE,LIMIT,EQID	
4248	268 4248	N	APP,CHARS,CLASS,DEST,FCB,FOLD,FORM,IMAGE,OFFLINE,SEP,UIRATE,LIMIT,EQID	
4370	278 AFP1	N	OFFLINE,UIRATE,EQID	
5080	291 5080	N	OFFLINE,UIRATE,EQID	
5081	291 5080	N	OFFLINE,UIRATE,EQID	
5210	287 3287	N	OFFLINE,UIRATE,EQID	
6090	291 5080	N	OFFLINE,UIRATE,EQID	
6091	291 5080	N	OFFLINE,UIRATE,EQID	
6262	268 4248	N	APP,CHARS,CLASS,DEST,FCB,FOLD,FORM,IMAGE,OFFLINE,SEP,UIRATE,LIMIT,EQID	
7171	283 3278	N	OFFLINE,UIRATE,EQID / EMUL3270,E3270HLD,OPDR	
8232	270 3088	N	OFFLINE,UIRATE,EQID	

Figure 77. Supported Hardware Report - VM Devices (Part 22 of 24)

---

TYPE-MODEL	UIM	VM D/T	CONS	SUPPORTED HARDWARE - VM DEVICES SUPPORTED PARAMETERS (VALUES) / FEATURES
9032	307	9032	N	OFFLINE,UIRATE,EQID
9032-3	307	9032	N	OFFLINE,UIRATE,EQID
9032-5	307	9032	N	OFFLINE,UIRATE,EQID
9033	307	9033	N	OFFLINE,UIRATE,EQID
9332-40	258	9332	N	OFFLINE,SHARED,UIRATE,MDC(OFF,DFLTOFF,DFLTON),EQID
9332-42	258	9332	N	OFFLINE,SHARED,UIRATE,MDC(OFF,DFLTOFF,DFLTON),EQID
9332-60	258	9332	N	OFFLINE,SHARED,UIRATE,MDC(OFF,DFLTOFF,DFLTON),EQID
9332-62	258	9332	N	OFFLINE,SHARED,UIRATE,MDC(OFF,DFLTOFF,DFLTON),EQID
9335-81	258	9335	N	OFFLINE,SHARED,UIRATE,MDC(OFF,DFLTOFF,DFLTON),EQID
9336-10	258	9336	N	OFFLINE,SHARED,UIRATE,MDC(OFF,DFLTOFF,DFLTON),EQID
9336-20	258	9336	N	OFFLINE,SHARED,UIRATE,MDC(OFF,DFLTOFF,DFLTON),EQID
9345	258	9345	N	OFFLINE,SHARED,UIRATE,MDC(OFF,DFLTOFF,DFLTON),EQID
9348-1	261	9348	N	OFFLINE,UIRATE,EQID / DUALDENS

---

Figure 78. Supported Hardware Report - VM Devices (Part 23 of 24)

---

KEY	SUPPORTED HARDWARE - VM DEVICES KEY DESCRIPTION
---	-----
TYPE-MODEL	- SUPPORTED DEVICE TYPE
UIM	- INDEX OF UNIT INFORMATION MODULE SUPPORTING THIS DEVICE TYPE
VM D/T	- VM DEVICE TYPE
CONS	- DEVICE TYPE IS SUPPORTED AS VM CONSOLE
SUPPORTED PARAMETERS (VALUES) / FEATURES	- LIST OF SUPPORTED PARAMETERS (WITH SELECTION VALUES) AND FEATURES
Y	- DEVICE TYPE HAS THE CAPABILITY
N	- CAPABILITY IS NOT AVAILABLE
(R)	- PARAMETER IS REQUIRED

---

Figure 79. Supported Hardware Report - VM Devices (Part 24 of 24)



## Graphical Configuration Reports

This section contains one example for an LCU report. "Create Graphical Configuration Reports" on page 71 describes how to produce this report.

### LCU Report

The LCU report shows all logical control units for the designated processor. Each diagram shows one or more logical control units.

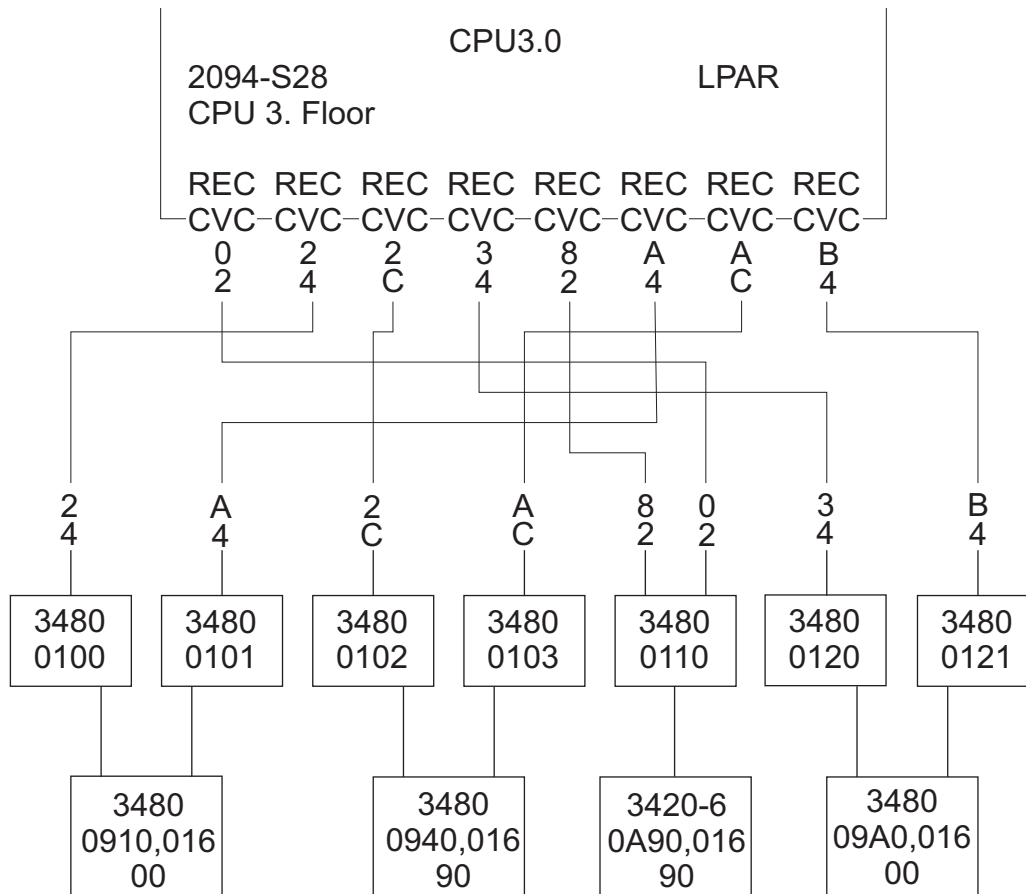

Figure 81. LCU Report

## IODF Compare Reports

The following figures show examples of IODF compare reports that can be produced by the IODF compare function of HCD. Not all possible reports are shown, and not all examples are shown completely. "Compare Functions" on page 72 describes how to produce these reports.

For XMP processors, the processorID for the comparison is shown together with the channel subsystem in question, for example, XMP01.1

With all IODF reports where channel subsystems of XMP processors are involved, you can compare two channel subsystems.

You can also compare an SMP processor to a channel subsystem of an XMP processor. If this kind of comparison is limited by processor only, the SMP processor is compared to channel subsystem 0 of the XMP processor.

## Processor Compare Report

Processor Compare Report		TIME: 10:40 DATE: 2004-12-22 PAGE A - 1	
New IODF name: BOKA.IODF75.WORK.R17		Old IODF name: BOKA.IODF76.WORK.R17	
PROC	New IODF	Old IODF	Description
GOLDENE1	Actual Data with 4 CSSes primary 2094-S38	Old Data with 4 CSSes	Processor Description continued
GOLDENE2	Added LPAR 2094-S28  with 4 CSSes secondary 2094-S28 80800002795A209409 + -01-1314:37:54 ERV01	80800002795A209409 + -01-2316:53:04	Processor Configuration Mode Processor Type Processor Serial Number Processor Network Name of SNA Address Processor CPC Name of SNA Address Processor Description continued Processor Token continued Processor Local System Name

Figure 82. Processor Compare Report

# Channel Subsystem Compare Report

With this report, you can compare two channel subsystems of the same XMP processor or a XMP processor's channel subsystem with an SMP processor.

Channel Subsystem Compare Report

TIME: 13:03 DATE: 2014-06-23 PAGE A - 2

New IODF name: BVTH.IODFA1.DOCU.Z22.WORK

Old IODF name: BVTH.IODFA0.DOCU.Z22.WORK

Limited to New Processor Id: P2964

Old Processor Id: P2964

P2964	4	Actual Data	Old Data	
		CSS 4 of P2964	same	Channel Subsystem Description
		65280	same	Maximum Numbers of Devices in Subchannel Set 0
		65535	same	Maximum Numbers of Devices in Subchannel Set 1
		65535	same	Maximum Numbers of Devices in Subchannel Set 2
		65535	same	Maximum Numbers of Devices in Subchannel Set 3
P2964	5	Actual Data	Old Data	
		modify CSS 5 SS1		Channel Subsystem Description
		65280	same	Maximum Numbers of Devices in Subchannel Set 0
		65000	65535	Maximum Numbers of Devices in Subchannel Set 1
		65535	same	Maximum Numbers of Devices in Subchannel Set 2
		65535	same	Maximum Numbers of Devices in Subchannel Set 3

Figure 83. Example of a Channel Subsystem Compare Report

# PCIe Function Compare Report

The PCIe function compare report shows the changes in the IDs and attributes of PCIe functions between processors of two IODFs.

PROC		FID	New IODF	Old IODF	Description
P2964	012			Deleted	
				111 ROCE 2 VF and 2 pnetids, + a=lp01 PNETID1 ID1302	Channel ID (CHID) Function Type Virtual Function ID (VF) Function Description continued Physical Network ID 1 Physical Network ID 2 Physical Network ID 3 Physical Network ID 4
				>> LP01	Partition in Access List
				>> LP21 >> LP24	Partition in Candidate List Partition in Candidate List
P2964	021		Added		
			4FE ROCE 30 max VF and 2 pneti + d,a=lp01 PNETID1 ID2		Channel ID (CHID) Function Type Virtual Function ID (VF) Function Description continued Physical Network ID 1 Physical Network ID 2 Physical Network ID 3 Physical Network ID 4
			>> LP01		Partition in Access List
			>> LP21 >> LP22		Partition in Candidate List Partition in Candidate List
P2964	FF0		Actual Data	Old Data	
			5	1	Virtual Function ID (VF)
			>> LP0A >> old deleted	>> new added >> LP01	Partition in Access List Partition in Access List
			>> LP0B >> old deleted >> old deleted	>> new added >> LP02 >> LP03	Partition in Candidate List Partition in Candidate List Partition in Candidate List

Figure 84. Example of a PCIe Function Compare Report

# Partition Compare Report

Partition Compare Report

TIME: 16:14 DATE: 2003-01-17 PAGE B - 4

New IODF name: SEL.IODF00.COMP200.NEW

Old IODF name: SEL.IODF00.COMP200.OLD

Limited to New Processor Id: PROCCCHK Old Processor Id: PROCCCHK

PROC	PART	New IODF	Old IODF	Description
PROCCCHK.0	PART1	Actual Data	Old Data	
		1 OS test_system_1	same same same	Partition Number Partition Usage Partition Description
PROCCCHK.0	PART2	Added		
		2 OS test_system_2		Partition Number Partition Usage Partition Description

...

Figure 85. Example of a Partition Compare Report

# Channel Path Compare Report

Channel Path Compare Report

TIME: 10:55 DATE: 2010-10-21 PAGE C - 1

New IODF name: BOKA.IODF00.GR.WORK

Old IODF name: BOKA.IODF01.GR.WORK

PROC	CHPID	New IODF	Old IODF	Description
MR33333Y.0	17	Added		
		n/a		Channel ID (CHID)
		IQD		Channel Path Type
		SHR		Channel Path Operation Mode
		undefined		Channel Path Description
		not managed		Connects to Dynamic Switch
none		Channel Path Managed Indicator		
n/a		Channel Path I/O Cluster Name		
n/a		HCA Adapter ID		
n/a		HCA Port		
40		MTU size (in KB)		
B		IQD Function		
n/a		Queue Prioritization		
		>> MR000001		Partition in Access List
		>> MR00000F		Partition in Candidate List
MR33333Y.0	18	Added		
		n/a		Channel ID (CHID)
		IQD		Channel Path Type
		SHR		Channel Path Operation Mode
		undefined		Channel Path Description
		not managed		Connects to Dynamic Switch
none		Channel Path Managed Indicator		
n/a		Channel Path I/O Cluster Name		
n/a		HCA Adapter ID		
n/a		HCA Port		
64		MTU size (in KB)		
X		IQD Function		
n/a		Queue Prioritization		
		>> MR000001		Partition in Access List
		>> MR00000F		Partition in Candidate List

Figure 86. Example of a Channel Path Compare Report

# Control Unit Attachment Compare Report

Control Unit Attachment Compare Report

TIME: 14:21 DATE: 2000-12-08 PAGE D - 4

New IODF name: BOKA.IODF38

Old IODF name: BOKA.IODF38.TEMP

Limited to New Processor Id: FR38LPAR Old Processor Id: FR38LPAR

PROC	CU	New IODF	Old IODF	Description
FR38LPAR	2000	Actual Data	Old Data	
		S *	same	Protocol
		2 *	same	I/O Concurrency Level
		1	same	Control Unit Address
		00,256	same	Unit Address, Number of addresses
>> 07.9B	>> same	Connected Channel Path, Destination Link Address		
>> 0C.70	>> same	Connected Channel Path, Destination Link Address		
>> 6B.9E	>> same	Connected Channel Path, Destination Link Address		
5	same	Number of Connected Managed Channel Paths		
FR38LPAR	2200	Actual Data	Old Data	
		S *	same	Protocol
		2 *	same	I/O Concurrency Level
		3	same	Control Unit Address
		00,256	same	Unit Address, Number of addresses
>> 0B.B9	>> same	Connected Channel Path, Destination Link Address		
>> 17.9B	>> same	Connected Channel Path, Destination Link Address		
>> 6B.9A	>> same	Connected Channel Path, Destination Link Address		
5	same	Number of Connected Managed Channel Paths		

Figure 87. Example of a Control Unit Attachment Compare Report

## Device Attachment Compare Report

Device Attachment Compare Report		TIME: 08:41 DATE: 1997-11-06 PAGE E - 1		
New IODF name: REDDE.IODF00.COMP1		Old IODF name: REDDE.IODF00.COMP2		
Limited to New Processor Id: LPARPROC		Old Processor Id: LPARPROC		
Limited to New Partition Id: PART1		Old Partition Id: PART3		
PROC	Device, Range	New IODF	Description	
LPARPROC	0100,16	Actual Data	Old Data	
		00	same	Unit Address
		Yes	same	Illegal Status Detection Facility
		No	same	Timeout Facility
undefined	same	Preferred Channel Path		
>> PART1	>> new added	Partition in Explicit Device Candidate list		
>> PART3	>> same	Partition in Explicit Device Candidate list		
>> access list	>> candidate list	Relation to Limiting LPAR		
LPARPROC	0200,15	Actual Data	Old Data	
		00	same	Unit Address
		Yes	same	Illegal Status Detection Facility
		No	same	Timeout Facility
undefined	same	Preferred Channel Path		
>> access list	>> candidate list	Relation to Limiting LPAR		

Figure 88. Example of a Device Attachment Compare Report

## Control Unit Compare Report

Control Unit Compare Report		TIME: 08:41 DATE: 1997-11-06 PAGE F - 1		
New IODF name: REDDE.IODF00.COMP1		Old IODF name: REDDE.IODF00.COMP2		
Limited to New Processor Id: LPARPROC		Old Processor Id: LPARPROC		
Limited to New Partition Id: PART1		Old Partition Id: PART3		
CU		New IODF	Description	
0200		Actual Data	Old Data	
		3990	same	Control Unit Type
			same	Control Unit Serial Number
			same	Control Unit Description
	>> BASPROC	>> new added	Attached to Processor	
	>> LPARPROC	>> same	Attached to Processor	
	>> P2084.1	>> same	Attached to Processor	
>> 0200,15	>> same	Attached Device, Range		
>> 020F	>> same	Attached Device, Range		
>> 0210,11	>> same	Attached Device, Range		
>> 01 E4	>> same	Connected to Switch, Port		
>> 01 E5	>> same	Connected to Switch, Port		
>> access list	>> candidate list	Relation to Limiting LPAR		

Figure 89. Example of a Control Unit Compare Report

# Device Compare Report

Device Compare Report

TIME: 08:41 DATE: 1997-11-06 PAGE G - 1

New IODF name: REDDE.IODF00.COMP1

Old IODF name: REDDE.IODF00.COMP2

Limited to New Processor Id: LPARPROC Old Processor Id: LPARPROC

Limited to New Partition Id: PART1 Old Partition Id: PART3

Device, Range	New IODF	Old IODF	Description
0100	Actual Data	Old Data	
	9032	same same same same	Device Type Serial Number Device Description VOLSER
	>> BASPROC >> old deleted >> LPARPROC >> P2084.1	>> new added >> BASPROC1 >> same >> same	Attached to Processor Attached to Processor Attached to Processor Attached to Processor
	>> 0100	>> same	Connected to Control Unit
	>> access list	>> candidate list	Relation to Limiting LPAR
	0200,15	Actual Data	Old Data
3390		same same same	Device Type Serial Number Device Description
>> BASPROC >> LPARPROC		>> new added >> same	Attached to Processor Attached to Processor
>> 0200 >> 0210		>> same >> same	Connected to Control Unit Connected to Control Unit
>> OSOSOSOS		>> same	Attached to Operating System Configuration
>> access list		>> candidate list	Relation to Limiting LPAR

Figure 90. Example of a Device Compare Report

# Switch Compare Report

Switch Compare Report

TIME: 13:40 DATE: 1997-03-27 PAGE H - 1

New IODF name: BERT.IODF99.TESTMSG1

Old IODF name: BERT.IODF99.TESTMSG

SWITCH	New IODF	Old IODF	Description
01	Actual Data	Old Data	
	9032	same same same	Switch Type Switch Serial Number Description
	>> 1000 1000 >> 1010 1010 >> 1020 1020	>> same >> same >> same	Switch Control unit, switch device Switch Control unit, switch device Switch Control unit, switch device
02	Actual Data	Old Data	
	9032	same same same	Switch Type Switch Serial Number Description
	>> 2222 2222 >> 3333 3333 >> 4444 4444	>> same >> 4444 4444 >> new added	Switch Control unit, switch device Switch Control unit, switch device Switch Control unit, switch device

Figure 91. Example of a Switch Compare Report

## Switch Detail Compare Report

For switches connected to a XMP processors channel path, the channel subsystem in question is shown. The identifier used for an attached channel path will be of the form ProcID.CssID CHPID

---

Switch Detail Compare Report TIME: 10:38 DATE: 1997-10-09 PAGE I - 9

New IODF name: BERT.IODFAA.XMIT.PROD.WORK Old IODF name: BERT.IODFAA.XMIT.PROD

Limited to New Switch Id: 01 Old Switch Id: 01

SWITCH	PORT	New IODF	Old IODF	Description
01	B0	Actual Data	Old Data	
		installed	same	Port Installed Flag Port Name
		>> 0800 >> P2084.1 31	>> same >> same	Attached to Control Unit Attached to Processor, Channel Path
01	B1	Actual Data	Old Data	
		installed CU_400	same CU_500	Port Installed Flag Port Name
		>> 0800	>> 0500	Attached to Control Unit
01	B2	Actual Data	Old Data	
		installed PROCA_CP18 occupied	same not occupied	Port Installed Flag Port Name Port Occupied Flag

Figure 92. Example of a Switch Detail Compare Report

# Switch Configuration Detail Compare Report

Switch Configuration Detail Compare Report      TIME: 13:40    DATE: 1997-03-27    PAGE K -    1

New IODF name: BERT.IODF99.TESTMSG1

Old IODF name: BERT.IODF99.TESTMSG

SWITCH	SWCONFIG	PORT	New IODF	Old IODF	Description
01	BASIC	E1	Actual Data	Old Data	
			Unblocked	same	Blocked / Unblocked Connection
			>> F1	>> same	Port of Dedicated Connection
01	BASIC	E2	Actual Data	Old Data	
			Unblocked	same	Blocked / Unblocked Connection
			>> E7	>> same	Port of Allowed Connection
			>> F3	>> same	Port of Allowed Connection
			>> F5	>> same	Port of Allowed Connection
>> E8	>> same	Port of Prohibited Connection			
01	BASIC	E3	Actual Data	Old Data	
			Unblocked	same	Blocked / Unblocked Connection
			>> E8	>> same	Port of Prohibited Connection
			>> E9	>> same	Port of Prohibited Connection
>> EA	>> same	Port of Prohibited Connection			

Figure 93. Example of a Switch Configuration Detail Compare Report

# OS Device Compare Report

OS Device Compare Report TIME: 08:32 DATE: 1997-11-06 PAGE R - 1

New IODF name: REDDE.IODF00.COMP1 Old IODF name: REDDE.IODF00.COMP2

Limited to New Operating System Id: OS1 Old Operating System Id: OS1

OS	Device, Range	New IODF	Old IODF	Description
OS1	0100	Actual Data	Old Data	
		9033 SWCH Yes Yes	same same same same	Device Type Name of Generic Value(s) of Parameter OFFLINE Value(s) of Parameter DYNAMIC
OS1	0200,32	Actual Data	Old Data	
		3390 3390 No * Yes	same same same same	Device Type Name of Generic Value(s) of Parameter OFFLINE Value(s) of Parameter DYNAMIC
OSOSOSOS	01D1,4	Actual Data	Old Data	
		3390 3390 No Yes	same same same same	Device Type Name of Generic Value(s) of Parameter OFFLINE Value(s) of Parameter DYNAMIC

\* indicates this value as default value (only shown when both sides exist)

Figure 94. Example of an OS Device Compare Report

# OS Console Compare Report

OS Console Compare Report TIME: 12:41 DATE: 1997-08-26 PAGE Q - 1

New IODF name: USER.IODF03.WORK Old IODF name: HCD.IODF01.WORK

Limited to New Operating System Id: OPSYS01 Old Operating System Id: OPSYS01

OSCONFIG DEVICE	New IODF	Old IODF	Description
OPSYS01 0001	Actual Data	Old Data	
	2	1	Order Number
OPSYS01 0002	Added		
	1		Order Number

Figure 95. Example of an OS Console Compare Report

---

## CSS / Operating System Device Compare

---

CSS / OS Device Compare

TIME: 17:00 DATE: 2009-11-17 PAGE S - 1

IODF Name : SEL.IODF00.WORK1  
Processor Id: PROC01 Cms Id: 0 Partition Name: PART00 ./ Operating System Configuration Id: MVS1

Device, Range		CSS Device Type	OS Device Type
A000,80	*	3390B	same
A050,176	-	3390A	same
A200,80	-	3390B	same
E210,16	-	3390	3800-1
E220,1000		3390	same

\* Devices relate to the limiting LPAR via CHPIDs which have the limiting LPAR in the candidate list only.

- Devices relate to the limiting LPAR via CHPIDs but the device is excluded from the CSS with an explicit device candidate list.

---

Figure 96. CSS / Operating System Device Compare



---

## Chapter 14. Problem Determination

### Overview

The information in this appendix is intended to help you diagnose problems that may arise with definitions that were created by the use of HCD. It explains:

- How to identify problems
- What diagnostic information and tools you can use
- How to search problem reporting data bases

### Product Identifiers

- Module Prefix: CBD
- Component ID: 568411219

For more information on identifiers, refer to the *HCD/HCM for z/VM Program Directory*.

---

## Identifying Problems

Before you can begin to diagnose a system problem, you have to know what kind of problem you have.

The following table contains examples of symptoms you can use to determine a problem. Each symptom refers to a corresponding section for further problem diagnostic.

*Table 9. Symptoms of System Problems*

Symptom	Corresponding Section
HCD terminates abnormally	"HCD Abnormal Termination" on page 238.
Wait State during IPL	"Error During IODF Statement Processing" on page 240.
Messages CBDA400I to CBDA420I are displayed	"Problems with Help Information Provided by HCD" on page 240
Output of textual report is incorrect or incomplete	"Problems with Output of HCD Textual Reports" on page 241
Output of graphical report is incorrect or incomplete	"Problems with Output of HCD Graphical Reports" on page 241
Messages during initialization of HCD	"Problems During Initialization of HCD" on page 243
A string like ?PARMnn? appears on the Define Device Parameters / Features panel	"Problems with UIMs" on page 244
A UIM is flagged in error on the Installed UIMs panel	"Problems with UIMs" on page 244
Messages during migration	"Resolving Migration Errors" on page 115
HCD does not display an error message when you make a mistake	"HCD Internal Problems" on page 245
An HCD generated IOCP input file fails when using the IOCP program	"HCD Internal Problems" on page 245

## HCD Abnormal Termination

If HCD terminates abnormally, view the HCD message log that contains the termination message CBDA000I specifying the system abend code (also called abend code) and the reason code in the HCD message log.

Refer to the message descriptions shown in *z/OS and z/VM: Hardware Configuration Definition Messages*. Take the action as described under “Programmer Response”. If the message points to a probable logic error in one of the modules of HCD, develop a search argument for the problem-reporting data bases. If the search finds that the problem has been reported before, request the problem fix; if not, report the problem to IBM. For a list of additional information that should be provided, see the appropriate message explanation.

### Diagnosing System Abend Code '00F'

If HCD terminates with system abend code '00F', this abend code is accompanied by a reason code, which refers to one of the HCD messages describing the reason of the failure. Note that you have to view the HCD message log for the system abend code and reason code. The reason code consists of eight digits and has the format 'mnnnllll' where:

- m** Is the prefix indicating the HCD message range:
- 0** CBDAxxxx messages
  - 1** CBDBxxxx messages
  - 2** CBDCxxxx messages
  - 3** CBDDxxxx messages
  - 6** CBDGxxxx messages
- nnn** Is the message number within the HCD message range.
- llll** Is the message reason code describing in more detail the reason of the message.

The information provided by the abend code can be used as a quick reference into the message. For example, the reason code 00990106 means that:

- The message CBDA099I was issued.
- The message reason code is 0106.

The reason code 00150095 means that:

- The message CBDA015 was issued.
- The message reason code is 95.

Table 10 and Table 11 show what the search argument and the problem data could look like.

Table 10. Search Argument

Search Argument	Description	Example
AB/S0hhh	System abend code	AB/S000F
PRCS/mnnnllll	Reason code	PRCS/00990106
MS/ccccnnns	Message identifier	MS/CBDA099I

Table 11. Problem Data

Problem Data	Example
CBDA000 abend code and reason code	00F and 00990406

Table 11. Problem Data (continued)

Problem Data	Example
CBDA099 reason code	406
CBDA099 additional error information (content of HCDMLOG).  It is important that <i>all</i> information shown in HCDMLOG is recorded.	
Description of what type of action the user wanted to perform when the problem occurred	Add a Processor
The TRACE output file. (See "TRACE Command" on page 249 for instructions how to produce an HCD trace output.)	

### Diagnosing System Abend Other than '00F'

If HCD terminates with an abend code other than '00F' (indicated in the terminating message), proceed as follows:

1. Look at the explanation of the abend code and any reason code that accompanies the abend code. Take the recommended actions.
2. Look for any messages that accompany the abend. Take the recommended actions.

Problems occurring in the system may result in abend (abnormal end) processing. When an abend occurs, an abend completion code is given, an abend work area is filled in, and a dump is taken if DUMP is specified in the ABEND macro. Internal abends always specify DUMP.

Abend completion codes give the user some idea of why the error occurred and what part of the system may be responsible for the problem. So this may be a hint on where to start your diagnosis. These codes are explained in *z/VM: CP Messages and Codes*.

The abend dump contains information that enables the problem to be tracked further. Using the Dump Viewing Facility REGS command, the contents of the registers at the time the abend occurred can be displayed. The internal trace table and system control blocks can also be displayed. They aid in problem determination and debugging.

For more information on all types of abends and how to process abends, refer to the *z/VM: Diagnosis Guide*.

Table 12 and Table 13 on page 240 show what the search argument and the problem data associated with our example could look like.

Table 12. Search Argument

Search Argument	Description	Example
RIDS/CBDcccc	CSECT name	RIDS/CBDMGHCP
AB/S0hhh	System abend code	AB/S0106
PRCS/mnnnlll	Reason code	PRCS/000000B
MS/cccnns	Message identifier	MS/CSV011I

Table 12. Search Argument (continued)

Search Argument	Description	Example
FLDS/SDWAVRA VALU/cccc	SDWAVRA contents	

Table 13. Problem Data

<b>Problem Data</b>
SDWAVRA information
Accompanying messages
Component ID and FMID
Linkage editor output
Description of what type of action the user wanted to perform when the problem occurred
The TRACE output file.  (See "TRACE Command" on page 249 for instructions how to produce an HCD trace output.)

## Error During IODF Statement Processing

If an error occurs during the processing of an IODF statement which would result in the system coming up without the I/O configuration being defined as expected, then CP will enter a disabled wait state. This wait state could occur for any of the following reasons:

- The specified IODF file name is not valid.
- The IODF file could not be opened.
- The IODF file could not be read.
- The data in the IODF file was not valid.
- The specified OS configuration ID was not found in the IODF.

For more information on debugging CP, refer to the *z/VM: Diagnosis Guide*.

## Problems with Help Information Provided by HCD

In addition to CMS reference manuals, there is an online z/VM HELP Facility that you can refer to while you are logged onto the system.

You can receive online information about the messages described in this book using the z/VM HELP Facility. You can display information about a message by entering one of the following commands:

```
help msgid or help msg msgid
```

For example, to display information about message CBDD009I, you can enter one of the following commands:

```
help cbdd009i
```

or

```
help msg cbdd009i
```

For more information about using the HELP Facility, see the *z/VM CMS User's Guide*. To display the main HELP Task Menu, enter:

```
help
```

For more information about the HELP command, see the *z/VM CMS Command and Utility Reference* or enter:

```
help cms help
```

## Problems with Output of HCD Textual Reports

Use this procedure if you find problems that relate to the HCD report facility.

1. Check the output of the report job for messages that provide additional information.
2. For incorrect or incomplete output:
  - a. Compare the contents of the IODF with the output. For example, if the device features are not shown correctly in the OS device detail report, view the definitions of the device for which the report seems to be incorrect.
  - b. If you find out that the definitions in the IODF are correct, but the report output is incorrect, report this problem to IBM.

Table 14 shows what the problem data could look like.

Table 14. Problem Data

Problem Data	Example
Type of report that was to be created.	Control unit detail report
REXX that was used to create the report.	CBDSREP IODF00 WORKIODF A IODF00 REPORT A U
The content of the IODF for which the report was requested.  Refer to "TRACE Command" on page 249 to create an IODF dump.	

## Problems with Output of HCD Graphical Reports

When you have any problems printing or viewing a graphical configuration report, read the following problem descriptions. If you have any other problem, report the problem to IBM.

### Incorrect DCF, GDF, or GML Format in Output File

You can simply check, whether you have created the output format you have specified in the profile using the keyword GCR\_FORMAT. Browse or edit the created file.

**BookMaster** format will look like this:

```
:userdoc
.layout 1
.dr thick weight .4mm
.rh on
.sp 2
```

**DCF** format will look like this:

```
.df graph font X0GT20
.tr 31 AC BE BC 76 AB 30 BB 15 8F 77 CB 78 CC 80 EB 64 EC 6A FA 24 BF
.ll 240mm
.dr thick weight .4mm
.rh on
.sp 2
```

**GML** format will look like this:

```

:gdoc
.df graph font X0GT20
.tr 31 AC BE BC 76 AB 30 BB 15 8F 77 CB 78 CC 80 EB 64 EC 6A FA 24 BF
.ll 240mm
.dr thick weight .4mm
.rh on
.sp 2

```

If the output is not correct, make sure that:

- The HCD profile is allocated with ddname HCDPROF before invoking HCD.
- The profile contains the keywords GCR\_FORMAT=DCF or GML and GCR\_FONT with an appropriate font (for example, X0GT20 for 3820 printers).

For information on how to specify keywords in the HCD profile, refer to “Defining an HCD Profile” on page 26.

### **Illegible Printout when Using DCF or GML**

The output of a report file contains correct DCF and GML format, but the printout is illegible.

Make sure that:

- A monospace font (for example, X0GT20 for 3820 printers) is specified in the HCD profile using the keyword GCR\_FONT.
- The specified font is installed on your printer.

### **Output Exceeds Page Boundary**

The printed output exceeds page boundary.

Make sure that:

- During printing you specified a parameter to print the report in landscape format, that is to rotate the printout by 90 degree.
- The parameter LAYOUT 1 was specified to use the full page for the report.

### **Box Characters Are Not Correct**

When using DCF formatting, the box characters are not correct.

The graphical print facility uses special hex characters for the various box characters. These special characters are then translated to real box characters by means of the .tr command. If the selected font does not contain the box characters, you must either choose another font or modify the .tr command in the file generated by the graphical print facility. See the following table for information on which hex combinations HCD uses for the various box characters.

```
.tr 31 AC BE BC 76 AB 30 BB 15 8F 77 CB 78 CC 80 EB 64 EC 6A FA 24 BF
```

where:

<b>31</b>	Upper left corner
<b>BE</b>	Upper right corner
<b>76</b>	Lower left corner
<b>30</b>	Upper right corner
<b>15</b>	Junction (+)
<b>77</b>	Upward T
<b>78</b>	Downward T

- 80 Leftward T
- 64 Rightward T
- 6A Bar
- 24 Hyphen (dash)

Table 15 shows what the problem data could look like.

Table 15. Problem Data

Problem Data	Example
Type of report that was to be created.	LCU report
REXX that was used to create the report.	CBDSDRAW IODF00 WORKIODF A IODF00 SCRIPT A LCU PROC1
The content of the IODF for which the report was requested.  Refer to "TRACE Command" on page 249 to create an IODF dump.	

## Problems During Initialization of HCD

If a problem occurs during initialization, HCD does one of the following:

- Issues a message and continues the initialization
- Terminates the initialization

Whether the initialization of HCD *continues* or *terminates* depends on the error that is encountered as explained in the following.

### Initialization Continues

If a UIM service routine encounters an error during initialization, HCD works without this UIM. HCD pops up messages on the user's terminal to inform the user that messages were written to the message log.

**Note:** If an error is encountered in a UIM, HCD does not continue. An HCD abend '00F' is forced to provide a dump at the point where the error was detected.

### Initialization Is Terminated

The initialization is terminated either with an abend or with a message.

In case of an abend, the dialog:

- Puts message CBDA050I with abend code '00F' in the message log.
- Puts the message that is issued by a UIM service routine in the message log.

If an error is encountered in a UIM and dump processing is enabled, an HCD abend '00F' is forced to provide a dump at the point where the error was detected.

**Message CBDA041I:** Means that HCD is not able to find the UIMs. If this message is issued during initialization using the "CIT" variable, make sure that the UIMs are installed.

Table 16 on page 244 and Table 17 on page 244 show what the search argument and the problem data could look like.

Table 16. Search Argument

Search Argument	Description	Example
MS/cccnns	Message identifier	MS/CBDA041I
PIDS/UIM name	UIM name	PIDS/CBDUS258

Table 17. Problem Data

Problem Data	Example
UIM name	CBDUS258
Message ID(s) and full message text	CBDA041I
TRACE output file. Refer to "TRACE Command" on page 249.	

## Problems with UIMs

For information on converting and testing UIMs, refer to *z/OS MVS Device Validation Support*. To use with z/VM HCD, see "Using UIMs with z/VM HCD," on page 371.

The following explanations apply to UIMs provided by the installation and to UIMs provided by IBM.

### Messages During Initialization of HCD

Internal logic errors in UIMs are primarily found during the initialization of HCD. Refer to "Problems During Initialization of HCD" on page 243 for information on how to proceed in case of initialization problems.

### UIM Problems After Initialization of HCD

Internal logic errors in UIMs may also be discovered:

- During the definition of a device (as a string like ?PARMnn? on the *Define Device <=> OS Configuration Parameters* window in HCM. Message CBDA381I indicates that you may have installed a back-level UIM.
- In the *Supported Hardware Report* ("Supported Hardware Report" on page 199). If during initialization of HCD a UIM is flagged in error, messages CBDA070I or CBDA096I may be issued. Message CBDA070I means that the UIM does not match the corresponding UDT. Message CBDA096I means an unresolvable conflict between a VM and MVS UIM.

You can use the message log, together with a dump of the CMS virtual machine running HCD, and HCDTRACE to find the error in the UIM that failed. For more information on how to create a dump, refer to the *z/VM: Diagnosis Guide*.

If the error relates to an installation-provided UIM, make appropriate corrections. For information on converting UIMs, refer to *z/OS MVS Device Validation Support*. To use with z/VM HCD, see "Using UIMs with z/VM HCD," on page 371.

If the error relates to a UIM provided by IBM, report the problem.

Table 18 on page 245 and Table 19 on page 245 show what the search argument and the problem data could look like.

Table 18. Search Argument

Search Argument	Description	Example
MS/cccnns	Message identifier	MS/CBDA070I
PIDS/UIM name	UIM name	PIDS/CBDUS281

Table 19. Problem Data

Problem Data	Example
UIM name	CBDUS281
Message ID(s) and full message text	CBDA070I
Type of action the user wanted to perform	List installed UIMs
TRACE output file. Refer to "TRACE Command" on page 249.	

## HCD Internal Problems

When you have one of the following error situations, you probably have detected an internal HCD error:

- HCD displays wrong messages or does not display a message at all when you made a mistake.
- An HCD generated IOCP input file causes error messages when using the IOCP program.

Report problems like this to IBM.

Table 20 and Table 21 show what the search argument and the problem data could look like.

Table 20. Search Argument

Search Argument	Description	Example
MS/cccnns	Message identifier	
RIDS/CBDcccc	REXX utility	RIDS/CBDSPROD

Table 21. Problem Data

Problem Data	Example
Message ID(s)	
REXX utility	CBDSPROD
Type of action the user wanted to perform	Build production IODF
Description of configuration	

---

## Diagnostic Information and Tools

The information and tools described in this section help you to diagnose system problems.

### HCD Messages

In case of an error, HCD issues messages. Depending on what you are currently doing, the messages are written:

- In a message log
- In a migration log

### Message Log

Errors, warnings and informational messages are written to the message log. The user will be informed about this when leaving the dialog or switching to another IODF.

### Migration Log

HCD maintains a migration log that contains messages issued by the migration process.

Table 22 shows where you can find messages while working with HCD.

*Table 22. Where to Find HCD Messages*

Mode of Operation	You Find the Message
Utility mode	In the message log, that is the file allocated with ddname HCDMLOG. <sup>1</sup>
Migration of input files	In the migration log, that is the file allocated with ddname HCDPRINT
IPL	Trapped by IPL. A wait state code is issued.
<b>Note:</b> <sup>1</sup> The output shows the message number and text; for explanations refer to <i>z/OS and z/VM: Hardware Configuration Definition Messages</i> .	

## HCD Trace Facility

The output of the HCD trace facility provides information to locate internal HCD problems. It helps the IBM program system representative to identify the cause of a failure.

### File

The trace records generated by HCD are recorded in the trace file.

The trace file must be pre-allocated with a ddname of HCDTRACE. If the trace file is not allocated when HCD is invoked, no tracing takes place.

### Trace Records

The trace records show the control flow within the various HCD modules. Trace information is written into the trace file:

- Whenever a module (CSECT) gets control.
  - In this case, the passed parameter list is recorded together with the name and description of the invoked module.
- Whenever a module (CSECT) returns to its calling routine.
  - The passed parameter list containing the return and reason codes is recorded.

The trace uses a trace file which is predefined in size. If the trace file is filled up, the trace uses a wrap-around mechanism, that is, it is reused again.

When HCD is invoked, HCD overwrites the existing trace file with the new trace file. If you want to retain the existing file, you have to make sure that the file is saved.

Figure 97 on page 247 is an example of a trace output. The following explains the records you see:

17:00:13 96-08-01 Trace started

The time stamp shows when the trace facility was started. This record is useful to identify the trace files when multiple traces are produced on the same day.

PUSH CBDMSMSG - Message Routine 96214 HCS6031 17001352 08472028

This line indicates that control has been passed to another module at a certain time. In this example, the module named CBDMSMSG with service level '96214 HCS6031' received control at 17:00:13.52 at storage address X'08472028'. The records also give a short description of what the module does, and the parameter list that is passed to the called module.

CBDMSMSG Message destination: Screen

This trace entry is written by the called module.

POP CBDMSMSG - Message Routine 17001353

Indicates that control from the module named CBDMSMSG is returned to the calling routine at 17:00:13.53. Also, the passed parameter list is shown again, but now the parameter list contains the return/reason code indicating how successful the requested function was.

17:01:24 96-08-01 Trace stopped

The last entry in the trace output is a time stamp that indicates end of tracing.

```

17:00:13 96-08-01 Trace started.
.
.
PUSH CBDMSMSG - Message Routine 96214 HCS6031 17001352 08472028
00000000 D4E2C740 C3C2C4C1 F1F2F6C9 C9000100 *MSG CBDA126II****
00000010 00000000 00000000 00000000 00000000 ******
00000020 00000000 00000000 00000000 00000000 ******
00000030 00000000 00000000 00000000 00000000 ******
00000040 00000000 00000000 00000000 00000000 ******
00000050 00000000 00000000 00000000 00000000 ******
00000060 00000000 00000000 00000000 00000000 ******
00000070 00000000 00000000 00000000 00000000 ******
CBDMSMSG Message destination: Screen
00000000 E3D9C1C3 C5408396 94948195 8440A681 *TRACE command wa*
00000010 A2408183 838597A3 85844B *s accepted. *
POP CBDMSMSG - Message Routine 17001353
00000000 D4E2C740 C3C2C4C1 F1F2F6C9 C9000100 *MSG CBDA126II****
00000010 00000000 00000000 00000000 00000000 ******
00000020 00000000 00000000 00000000 00000000 ******
00000030 00000000 00000000 00000000 00000000 ******
00000040 00000000 00000000 00000000 00000000 ******
00000050 00000000 00000000 00000000 00000000 ******
00000060 00000000 00000000 00000000 00000000 ******
00000070 00000000 00000000 00000000 00000000 ******
.
.
.
17:01:24 96-08-01 Trace stopped.

```

Figure 97. Example: Trace Output

Figure 98 on page 248 is an extract of a trace output when an abend occurred. The following explains the record in the example.

**E S T A E:** The entries show information that was recorded by the HCD ESTAE routine. Entries under *Diagnostic stack* list the modules that were executing when the abnormal termination occurred, together with the service levels. The first entry

names the module that ended abnormally; in this example, the module is CBDMYCCB. The entries also show the control flow between the various HCD modules and the load address of the module. In this example:

- Module CBDMYDCC called module CBDMYCCB loaded at 212E0EF8.
- Module CBDMGDIA called module CBDMYDCC loaded at A12D4000.
- Module CBDMGHCP called module CBDMGDIA loaded at A1846B50.
- and so on.

```
*****
*           E S T A E                               *
*           System abend code   : 0C4                *
*           Reason code        : 00000011           *
*           HCD version        : z/OS 2.3 HCD       *
*           Diagnostic stack    : CBDMYCCB 15238    HCS77B0 212E0EF8 *
*                               CBDMYDCC 15237    HCS77B0 A12D4000 *
*                               CBDMGDIA 15194    HCS77B0 A1846B50 *
*                               CBDMGHCP 15197    HCS77B0 800695E0 *
*                               *                   *
*           Module name       : CBDMGHCP            *
*           Entry point address: 000695E0          *
*           PSW                : 078D1000 A12FB2AE *
*                               *                   *
*           R0 00000030 R1 21AD3000 R2 21AD3194 R3 00002F10 *
*           R4 21305608 R5 21305608 R6 21306607 R7 212FB1CF *
*           R8 21307606 R9 21308605 R10 00000450 R11 21AD35E4 *
*           R12 A12FA1D0 R13 21305AD4 R14 21ADF060 R15 21B5BF10 *
*****
```

Figure 98. Example: Trace Output in Case of Abend

## Activating the Trace

The trace can be activated either:

- in HCM: menu bar choice *Options*, pull down choice *Activate HCD Trace*.
- By invoking HCD (for details see Chapter 12, “How to Invoke the HCD Functions,” on page 119)
  - with the TRACE option specified in the passed parameter string as shown in the following example:

```
FILEDEF HCDTRACE DISK HCD TRACE A
OSRUN PARM='TRACE,REPORT,CSMEN,PROC1,PART1,MVS1,00'
```

- with the TRACE option specified in the CBDCONF NAMES file for each REXX utility:

```
trace = 'TRACE,' /* No trace active. To activate */
/* tracing, specify 'TRACE,' */
```

To limit the trace, specify the TRACE command in the in HCD profile followed by RESET followed by the trace-categories as shown below:

```
/* ***START OF SPECIFICATIONS***** */
/*
/* Module Name - *-----*
/*                * CBDSDFPF *
/*                *-----*
/*
/* Descriptive Name - z/VM HCD Sample Profile
/*
/* COPYRIGHT -
/* 5739-A03 (C) COPYRIGHT IBM CORP. - 1991, 2002
/* LICENSED MATERIALS - PROPERTY OF IBM
/* SEE COPYRIGHT INSTRUCTIONS, G120-2083
/*
/*
```

```

/* ***** */
/* add any profile statements below */
/* */
/* OPTIONS FOR DEBUGGING */
/* */
TRACE RESET UTILITY HOM LEVEL=255

```

This example will trace all (Level=255) utilities and HOM routines.

- By specifying the TRACE command in the HCD profile, see “Defining an HCD Profile” on page 26 for the TRACE profile statement.
- in the Login dialog of HCM you can select the *HCD Trace* checkbox.

The tracing stays active until either HCD terminates or in HCM you deselect the HCD trace.

### **TRACE Command**

The TRACE command activates and deactivates the HCD trace facility. The command allows you also to limit the detail of data written into the trace file by requesting that only certain functions and details should be traced.

The TRACE command can be specified in the HCD profile (see “TRACE Command” on page 27).

For HCD to write the output to the trace file, the TRACE command must be specified with at least one trace category (or you must have invoked HCD with the TRACE parameter, see “Activating the Trace” on page 248). To view the trace output, you have to close the trace file first. You can do this by leaving HCD.

The format of the command is as follows:

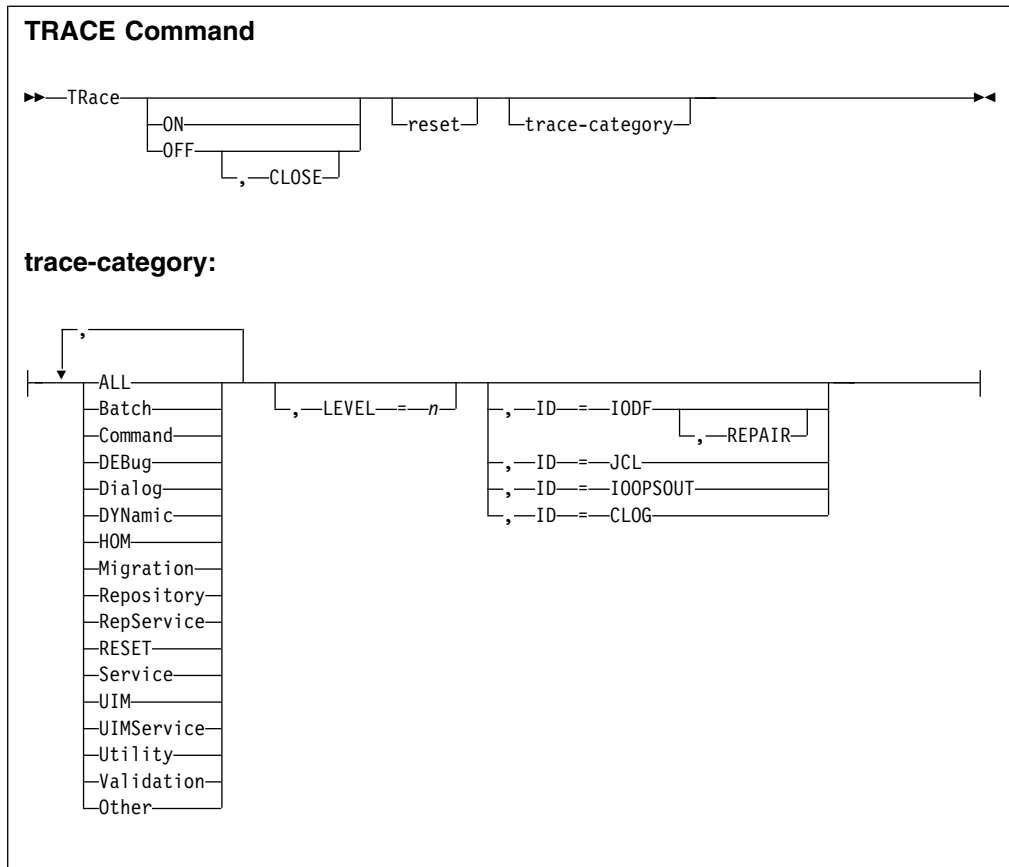

**Note:**

1. You may abbreviate some of the keywords. The characters you have to use are indicated by uppercase (you must then omit lowercase). For example RepService may be abbreviated as RS.
2. At least one parameter must be specified with TRace.

**ON** Starts the trace facility.

**OFF** Stops the trace facility.

**CLOSE**  
Closes the trace data set.

**Note:** ON, OFF and CLOSE can not be used if the profile is allocated by the HCD dispatcher and used by HCM.

**reset** Reset all currently active categories, LEVEL and ID. If not using RESET, HCD will remember the trace categories specified with previous trace commands and adds them up. If combined with trace categories, it should be specified before the categories, because the keywords and categories are evaluated in sequence. RESET at the end would clear the specified trace category.

**trace category**  
Specifies the functional scope to be traced:

**ALL** Traces for all categories except DEBug and RepService. To have a complete trace, use categories ALL, DEBug, RepService.

**Batch** Trace all batch routine.

**Command**

Trace all command routines.

**DEBug**

Traces internal services (not included, when ALL is specified).

**Dialog**

Trace all dialog routines.

**DYNamic**

Trace all dynamic routines.

**HOM** Trace all object management routines.

**Migration**

Trace all migration routines.

**Repository**

Trace all repository main routines.

**RepService**

Trace all repository service routines. (Not included, when ALL is specified).

**RESET**

Reset all currently active categories, LEVEL and ID.

**Service**

Trace all service routines.

**UIM** Trace all UIM routines.

**UIMService**

Trace all UIM service routines.

**Utility** Trace all utility routines.

**Validation**

Trace all validation routines.

**Other** Trace all other not yet mentioned routines.

**LEVEL=*n***

Assigns a level of detail to the functions to be traced, where *n* is a decimal number ranging from 0 to 255. If the option is omitted a level of 0 is assumed. The TRACE option described in "Input Parameter String" on page 120 is equivalent to the command TRACE ON,ALL,LEVEL=255.

**ID=*nnnnnnnn***

Writes into the trace file all HCD trace statements that are labelled with this eight-character ID.

**ID=IODF**

Writes an IODF dump into the trace data set. This parameter cannot be specified in the HCD profile.

**REPAIR**

Removes detected errors in the work IODF and reports corrections in the trace data set.

**Trace Command via HCD Profile**

- If HCD is started with the TRACE keyword, (for example, HCM is started with the HCDTrace box in the HCM login panel checked), initially *all* the trace categories will be traced. After the HCD profile has been read, however, the TRACE parameters there may modify the TRACE behavior.

- The TRACE parameters set in the HCD profile will also influence the TRACE behavior if you activate the tracing in HCM at a later time.
- The TRACE parameters set in the HCD profile will determine the contents of the trace as long as HCD runs.
  - If you use the RESET option followed by trace categories *cat1,cat2,...,catn*, then only the categories *cat1,cat2,...,catn* will be considered. The RESET option must be the first option because the trace categories are additive (LEVEL is set to 0).
  - Specifying the keyword off will terminate the startup trace.
  - Specifying the keyword on will start the HCD trace (if not already started) and will invoke the trace parameters of the TRACE statement.
  - Specifying LEVEL=*n* will set the level of trace detail. If the LEVEL parameter is not set, then the trace will use the default level of 5. For an example of a TRACE command in the HCD profile, see “Activating the Trace” on page 248.
- If no categories are set explicitly, then all trace categories will be active.

### Repair an IODF

If your IODF contains defects, some of them can be repaired using the HCM function **Check Configuration File** (in **Utilities**). From the upcoming dialog then select radio button **IODF** and check the option **Repair**.

First, your IODF must be set in update mode to correct defects. You can do this, for example, by changing any description field in your work IODF. A production IODF cannot be repaired.

Each corrected defect is recorded in the trace data set with the string:  
Defect has been corrected.

If a defect has been repaired, the following message is issued:  
CBDA998I, Defect(s) detected in IODF xxx. Repair action performed is issued.

If defects in the IODF cannot be repaired via the REPAIR option, you may have to rebuild the IODF. You can accomplish this task by exporting the configuration data from the IODF using the REXX utility CBDSCONF. (See “Build I/O Configuration Data (CBDSCONF)” on page 140.) You can then migrate this data to a new IODF:

1. Using HCM, export configuration types Processor, Operating System and Switch with configuration ID “All switches” from the HCM drop down box in the **Export IOCP or I/O Configuration Statements** dialog into three different output data sets. This will generate I/O configuration statements for all processor, operating system and switch configurations. You can set the profile option SHOW\_CONFIG\_ALL to YES to also generate configuration statements for unconnected control units and devices, in addition to those for switches. (See “Export/import Additional Configuration Objects” on page 30.)
2. Migrate the processor, OS configuration and switch data into a new IODF. Either use HCM for this task, or use the REXX utility CBDSMIGR. (See “Migrate I/O Configuration Statements (CBDSMIGR)” on page 126.)
3. Verify that the new IODF includes all data (for example, using compare reports). If necessary, add any missing items manually.
4. Check that the IODF is free from defects.

---

## Searching Problem Reporting Data Bases and Reporting Problems

Search arguments are used to search problem reporting data bases. If the problem being diagnosed was already reported and the symptoms entered into the data base, the search will produce a match.

To perform a search, do the following:

1. Analyze the problem reporting data base and develop a search argument using the information provided in the boxes labeled Search Argument.
2. Complete the digits (such as ccc, nnn, hhh) according to the applicable conditions. For example, if the message CBDA099I was received, the developed search argument for message identifier would be: MS/CBDA099I. An example is shown in Table 10 on page 238.
3. Use the search arguments to search problem reporting data bases. If the search finds that the problem has been reported before, request a fix from IBM.  
If the search is unsuccessful, report the problem to the IBM Support Center. Submit the information that is listed in the Problem Data tables. An example is shown in Table 11 on page 238.

For more detailed information on these steps, refer to the *z/VM: Diagnosis Guide*.



---

## Chapter 15. Migration Scenarios to z/VM HCD for z/VM and z/OS

---

### Scenario 1: How to Migrate to HCD in a z/VM Environment Without z/OS

In this scenario, we assume that no IODF is existing, so that an IODF must be created on one of the z/VM systems.

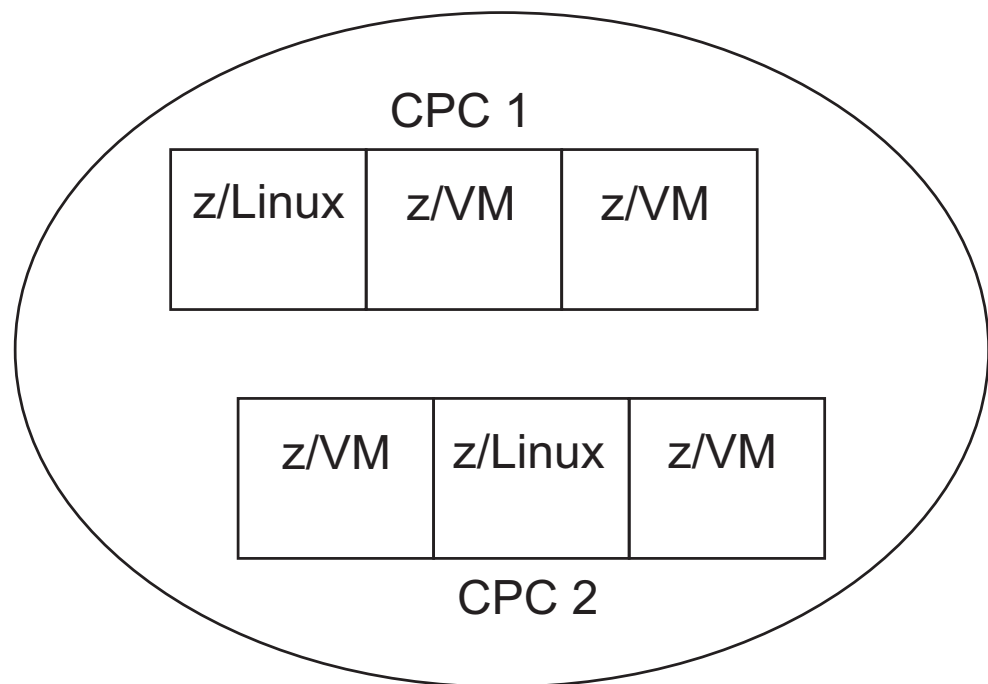

Figure 99. z/VM Environment without z/OS

Here is the list of steps to be performed:

- “Step 1. Prepare the IOCP deck for HCD” on page 256
- “Step 2. Create and Initialize an Empty Work IODF” on page 258
- “Step 3. Migrate the z/VM IOCP into the Work IODF” on page 259
- “Step 4. Migrate Your Operating System from an RDEV List” on page 261
- “Step 5. Check Your Configuration Specification” on page 261
- “Step 6. Build the Production IODF” on page 262
- “Step 7. Build the IOCDS” on page 263
- “Step 8. Set Up the SYSTEM CONFIG File” on page 263
- “Step 9. Perform a Power on Reset (POR)” on page 264
- “Step 10. Perform an Initial Program Load (IPL)” on page 265
- “Post-Migration Configuration Management with HCD” on page 268

After having successfully completed the migration to z/VM HCD, you can apply further updates to the IODF using z/VM HCM or z/VM HCD. To enable HCM to

draw a usable configuration diagram, observe the recommendations on how to prepare the IOCP input data set (see “Migration from an IOCP” on page 75) before migrating this data set to the IODF.

## Step 1. Prepare the IOCP deck for HCD

For this scenario, we assume as prerequisite that an IOCP deck exists on your z/VM system with the following file name and format:



In the following, a couple of examples are provided of how to apply extended migration statements into the IOCP. Extracts of a sample extended IOCP syntax are shown in Figure 100 on page 258.

The following sections introduce the extended migration statements available for the different configuration objects. In the given examples, the extended migration statements are printed in *bold/italic* font. Each example also mentions where HCM lets you benefit from the extended migration statements.

### Migration Statements for Processors

Extended migration statements for processors may contain a description of the processor and its network name and CPC name.

Table 23. Extended migration statements: Processors

Statement(s)	Sample
SNAADDR	<pre>ID      MSG2='IODF17 PRODIODF A - 2009-05-19 20:05', SYSTEM=(2094,1) *<i>\$HCDC\$</i>  <i>SNAADDR=(IBM390PS,POL1)</i></pre>

Where visible in HCM:

- Processor dialog

### Migration Statements for Partitions

Extended migration statements for partitions may describe the usage (OS, CF, or CF/OS) of the partitions of a processor or a channel subsystem.

Table 24. Extended migration statements: Partitions

Statement(s)	Sample
USAGE	<pre>RESOURCE PARTITION=((CSS(0),(HCDVM1,1),(HCDVM2,2),(HCDVM3,3),(* HCDVM4,4),(HCDVM5,5),(HCDVM6,6),(HCDVM7,7),(HCDVM8,8),(H* CDVM9,9),(HCDVM10,A),(*,B),(*,C),(*,D),(*,E),(*,F)),(CSS* (1),(ZLINUX1,1),(ZLINUX2,2),(ZLINUX3,3),(ZLINUX4,4),(ZLI* INUX5,5),(ZLINUX6,6),(ZLINUX7,7),(ZLINUX8,8),(ZLINUX9,9),* (ZLINUX10,A),(*,B),(*,C),(*,D),(*,E),(*,F))), MAXDEV=((CSS(0),20000,1000),(CSS(1),20000,1000)) *<i>\$HCDC\$</i>  <i>USAGE=(CF/OS,OS,OS,OS,OS,OS,OS,OS,OS,OS,CF/OS,OS,OS,OS,C* F/OS,CF/OS,OS,OS,OS,OS,OS,OS,OS,OS,OS,OS,OS,OS,OS,OS)</i></pre>

Where visible in HCM:

- Partitions dialog

### Migration Statements for CHPIDs

Extended migration statements for CHPIDs may specify the switchport to which the CHPID connects, and a description of the CHPID.

Table 25. Extended migration statements: CHPIDs

Statement(s)	Sample
SWPORT	<pre> CHPID PATH=(CSS(0),10),SHARED, PARTITION=((P8),(POLLP01,POLLP02,POLLP03,POLLP04,POLLP05* ,POLLP06,POLLP07,POLLP10)),SWITCH=02,PCHID=160,TYPE=CNC *\$HCDC\$ SWPORT=((02,27)) </pre>

#### Where visible in HCM:

- In the **CHPID** dialog
- In the **Edit CHPID** dialog
- In the HCM configuration diagram: visible as connection between CHPID 10 and switch port 27 of switch 02

### Migration Statements for Control Units

Extended migration statements for control units may contain a description, a serial number and the switches and ports, where they are connected

Table 26. Extended migration statements: Control units

Statement(s)	Sample
SERIAL SWPORT	<pre> CNTLUNIT CUNUMBR=0200,PATH=((CSS(0),36,38),(CSS(1),36,38)), UNITADD=((00,080)),LINK=((CSS(0),1F,9F),(CSS(1),1F,9F)), CUADD=3,UNIT=1750 *\$HCDC\$ SERIAL='3233' *\$HCDC\$ SWPORT=((17,1F),(17,9F)) </pre>

#### Where visible in HCM:

- in the **Locate One or More Control Units** list
- in the **Control Unit List** dialog
- in the HCM configuration diagram

### Migration Statements for Switches

Extended migration statements for switches may contain the switch ID, a description, information about the type and model and the installed ports.

Table 27. Extended migration statements: Switches

Statement(s)	Sample
SWITCH	<pre> *\$HCD\$ SWITCH SWID=02,PORT=((0C,FB),(FE,FE)),MODEL=5,UNIT=9032 *\$HCD\$ SWITCH SWID=17,ADDRESS=68,PORT=((00,1F),(80,9F)),UNIT=FCS *\$HCD\$ SWITCH SWID=10,ADDRESS=61,PORT=((04,43),(FE,FE)),UNIT=2032, SWPORT=((06,17,05),(07,17,04)) </pre>

#### Where visible in HCM:

- In the **Locate One or More Switches** list
- In the **Edit Switch** dialog

## Example of an IOCP Deck Using Extended Migration Statements

```

ID      MSG2='IODF17 PRODIODF A - 2009-05-19 20:05',          *
        SYSTEM=(2094,1)
*$HCDC$  SNAADDR=(IBM390PS, POL1)
RESOURCE PARTITION=((CSS(0),(HCDVM1,1),(HCDVM2,2),(HCDVM3,3),(
HCDVM4,4),(HCDVM5,5),(HCDVM6,6),(HCDVM7,7),(HCDVM8,8),(H*
CDVM9,9),(HCDVM10,A),(*,B),(*,C),(*,D),(*,E),(*,F)),(CSS*
(1),(ZLINUX1,1),(ZLINUX2,2),(ZLINUX3,3),(ZLINUX4,4),(ZLI*
NUNIX5,5),(ZLINUX6,6),(ZLINUX7,7),(ZLINUX8,8),(ZLINUX9,9),*
(ZLINUX10,A),(*,B),(*,C),(*,D),(*,E),(*,F))),
MAXDEV=((CSS(0),20000,1000),(CSS(1),20000,1000))
*$HCDC$  USAGE=(CF/OS,OS,OS,OS,OS,OS,OS,OS,OS,OS,CF/OS,OS,OS,OS,OS,C*
F/OS,CF/OS,OS,OS,OS,OS,OS,OS,OS,OS,OS,OS,OS,OS,OS)
CHPID   PATH=(CSS(0,1),0C),SHARED,                            *
        NOTPART=((CSS(0),(HCDVM1),(HCDVM2)),(CSS(1),
(ZLINUX1),(=))),                                             *
        PCHID=110,TYPE=OSC
CHPID   PATH=(CSS(0),10),SHARED,                               *
        PARTITION=((HCDVM2,HCDVM3),(HCDVM9,HCDVM10)),
SWITCH=02,PCHID=160,TYPE=CNC
*$HCDC$  SWPORT=(02,27)
...
CNTLUNIT CUNUMBR=0003,PATH=((CSS(0),0C),(CSS(1),0C)),UNIT=OSC
IODEVICE ADDRESS=(090,016),MODEL=X,UNITADD=00,CUNUMBR=(0003), *
        UNIT=3270
IODEVICE ADDRESS=(1090,004),MODEL=X,UNITADD=10,CUNUMBR=(0003),*
        UNIT=3270
CNTLUNIT CUNUMBR=0010,PATH=((CSS(0),32)),UNITADD=((00,008)), *
        CUADD=3,UNIT=FCTC
IODEVICE ADDRESS=(010,008),UNITADD=00,CUNUMBR=(0010),STADET=Y,*
        UNIT=FCTC
CNTLUNIT CUNUMBR=0200,PATH=((CSS(0),36,38),(CSS(1),36,38)), *
        UNITADD=((00,080)),LINK=((CSS(0),1F,9F),(CSS(1),1F,9F)),*
        CUADD=3,UNIT=1750
*$HCDC$  SERIAL='3233'
*$HCDC$  SWPORT=((17,1F),(17,9F))
IODEVICE ADDRESS=(200,020),CUNUMBR=(0200),STADET=Y,          *
        NOTPART=((CSS(0),P8,HCDVM),(CSS(1),D2)),UNIT=3390B
IODEVICE ADDRESS=(214,060),CUNUMBR=(0200),STADET=Y,          *
        NOTPART=((CSS(0),P8,HCDVM),(CSS(1),D2)),UNIT=3390A
...
*$HCDC$  SWITCH  SWID=10,ADDRESS=61,                          *
        PORT=((04,43),(FE,FE)),UNIT=2032,                    *
        SWPORT=((06,11,05),(07,11,04),(08,13,0A))
*$HCDC$  SWITCH  SWID=11,ADDRESS=62,                          *
        PORT=((04,83),(FE,FE)),UNIT=2032,                    *
        SWPORT=((04,10,07),(05,10,06))

```

Figure 100. Extracts from an IOCP with extended migration statements

## Step 2. Create and Initialize an Empty Work IODF

Create an empty work IODF into which the IOCP deck prepared in “Step 1. Prepare the IOCP deck for HCD” on page 256 will be migrated. For this purpose, use the **CBDSIODF** REXX utility (see “Create and Initialize an IODF (CBDSIODF)” in *z/VM I/O Configuration*).

### Example:

```
cbdsiodf iodf71 workiodf a 1024
```

This command creates an IODF file with the following properties:

filename:	filetype:	filemode:	format:	LRECL:	records:	blocks:
IODF71	WORKIODF	A6	F	4096	1024	1024

### Step 3. Migrate the z/VM IOCP into the Work IODF

In this step, we migrate the IOCP input file prepared in Step 1 into the work IODF created in Step 2. We do this by invoking the REXX utility **CBDSMIGR** to migrate the IOCP file called IOCPVM1 IOCP A into the IODF71 WORKIODF A under the new processor configuration POL1 of type 2094-S07 in LPAR mode, using support level H070331.

If different support levels are available for a processor type, you can specify the appropriate one. Otherwise, the highest support level is taken as a default. You can retrieve available support levels from the **Supported Hardware Report**.

#### Example:

```
cbdsmigr iodf71 workiodf a iocpvm1 iocp a i pol1 2094-S07 lpar h070331
```

For more information about the migration function, see topic *How to Migrate Existing Input Files* in *z/VM I/O Configuration*.

**Prerequisite:** To generate the additional keywords \$HCD\$ and \$HCDC\$ during IOCP file build, specify the following entry in the HCD PROFILE (which resides on the CBDIODSP user ID's A-disk):

```
MIGRATE_EXTENDED = YES
```

After the migration, file CBDSMIGR MESSAGES A informs you about a successful completion: Return Code was 0

#### How to Debug a Migration Problem

Depending on errors in the IOCP input file, HCD may create the following files:

```
CBDSMIGR MESSAGES A
CBDSMIGR MSGLOG A
CBDSMIGR LISTING A
```

If HCD creates an assembler listing, it may show more error details. Correct the error and run CBDSMIGR again. Now HCD just creates the MESSAGES and MSGLOG files.

Let us assume, you coded an IODEVICE statement for a 3270 device without a required MODEL=X specification:

#### **incorrect IODEVICE statement:**

```
CNTLUNIT CUNUMBR=0003,PATH=((CSS(0),0C),(CSS(1),0C)),UNIT=OSC
IODEVICE ADDRESS=(090,016),UNITADD=00,CUNUMBR=(0003), *
UNIT=3270
```

#### **same IODEVICE statement corrected:**

```
CNTLUNIT CUNUMBR=0003,PATH=((CSS(0),0C),(CSS(1),0C)),UNIT=OSC
IODEVICE ADDRESS=(090,016),MODEL=X,UNITADD=00,CUNUMBR=(0003), *
UNIT=3270
```

In such a case, HCD writes the following message into the related MESSAGES file:

```

HCD                                     Time: 14:06 Date: 09-07-09 Page: 1
z/VM 5.4.0 HCD

(1) FILE=IOCPVM1 IOCP A 1

Statement Orig Sev  Msgid    Message Text
      54  (1)  E  CBDA297I Control unit 0003 of type OSC cannot attach device 0090 of type 3270.
          I  CBDA516I No output written to IODF. VALIDATE processing forced due to errors.

Total Messages  Terminating  Error  Warning  Informational
              2                1        1          1

Return Code was 8 2

```

Figure 101. CBDSMIGR MESSAGES A1

The message points to an error in file IOCPVM1 IOCP A 1 and shows the assembler processing return code 2.

### How to Handle Migration Errors Due to HCD Validation Checks

As HCD performs strict validation checks, you may receive error messages when migrating your IOCP deck, that had been tolerated by z/VM.

With message *CBDA155I* as an example, this section shows you how to find the erroneous statement and how to correct the error.

Suppose, in the CBDSMIGR MESSAGES file, z/VM HCD reports error *CBDA155I* 3 in statement 179 2 of IOCP deck IOCPVM1 IOCP A 1:

```

HCD                                     Time: 11:10 Date: 09-07-28 Page: 1
z/VM 5.4.0 HCD

(1) FILE=IOCPVM1 IOCP A 1

Statement Orig Sev  Msgid    Message Text
      179 2 (1)  E  CBDA155I 3 Too many channel paths of type OSD, ... defined.
          Maximum is 48 for processor POL1.

```

In file CBDSMIGR LISTING, you can retrieve the IOCP statement 179 by searching for the string: *179 IS THE PREVIOUS IOCP/MVSCP STATEMENT NUMBER*.

The statement preceding this text line is the IOCP statement in error:

```

CHPID PCHID=611,PATH=(CSS(0,1,2,3),93),TYPE=OSD,SHARED
*, 179 IS THE PREVIOUS IOCP/MVSCP STATEMENT NUMBER

```

Now look for a user response to this message in *z/OS and z/VM Hardware Configuration Definition Messages*. In our case you find the following recommendations:

**User response:** You may do one of the following:

- Reduce the number of channel paths of the given type(s).
- Choose a different processor type-model or support level if available.

## Step 4. Migrate Your Operating System from an RDEV List

**Note:** If you do not want to use HCD to control the software (OS) configuration, skip this step. Otherwise, you can use two z/VM HCD REXX utilities **CBDSRDEV** and **CBDSMIGR** to perform this task.

### Step 4a: Create a RDEVLIST from Your Active VM System

First, by using utility **CBDSRDEV**, you generate an image of the RDEV control blocks from the running system. In other words, you create a file containing the current CP I/O configuration extracted from the active VM system (or more exactly, from the RDEV control blocks).

#### CBDSRDEV invocation syntax:

```
CBDSRDEV [outfile] [(REPlace)]
```

#### outfile

With this optional parameter, you can specify an output file for the I/O configuration. The default is CBDMCONF RDEVLIST A.

#### Example:

```
cbdsrdev vmconf rdevlist a
```

You will see the following console message:

```
*****  
Successful completion. File  VMCONF RDEVLIST          A  
created.  
*****
```

### Step 4b: Migrate the RDEVLIST into Your Work IODF

To migrate the I/O configuration retrieved in step 4a into your IODF (file IODF71 WORKIODF A) under the OS configuration name REALVM, you again use the **CBDSMIGR** utility:

#### CBDSMIGR utility:

```
▶▶cbdsmigr—iodf71—workiodf—a—vmconf—rdevlist—a—r—realvm————▶▶
```

At this point it is important to check the created files **CBDSMIGR MESSAGES** and **CBDSMIGR MSGLOG**. **CBDSRDEV** gets the device information from an RDEV control block. HCD matches the devices defined in the work IODF against the ones found in the **CBDSRDEV** output. If a device defined in the IODF is not online/available, then no control block entry has been found, and **CBDSMIGR MESSAGES** shows a corresponding warning message.

## Step 5. Check Your Configuration Specification

Now you have prepared a valid work IODF. At this point, it is recommended to verify the configuration and check, whether all is defined as you intended. For this purpose, you can use REXX utility **CBDSREP** to generate a variety of reports of your work IODF, for example, a *Channel Subsystem (CSS) Report* or a *VM Device Report*. With a parameter, you specify which type of report you want. How to

invoke this utility is described in topic *Print Configuration Reports (CBDSREP) of z/VM I/O Configuration*. Check the reports. If you discover discrepancies, you can manually update your original IOCP deck with your corrections. Remigrate the changed IOCP into your work IODF (**CBDSMIGR**). Now use parameter *IP* for partial migration instead of *I* in “Step 3. Migrate the z/VM IOCP into the Work IODF” on page 259.

If you performed the optional “Step 4. Migrate Your Operating System from an RDEV List” on page 261, it is recommended to compare the devices defined for the processor and the operating system. Run the REXX utility **CBDSCONF** to produce an output file from your work IODF containing I/O configuration statements for your operating system configuration.

The following REXX utility invocation produces the operating configuration statements for the operating system called REALVM:

```
cbdsconf iodf71 workiodf a realvm deck a o realvm
```

In the excerpt from output file REALVM DECK A shown in Figure 102, you see that, for example, device 1100 is defined for the operating system:

```
...  
IOCONFIG ID=00,NAME=REALVM,TYPE=VM  
RDEVICE DEVNO=(1100,1),DEVTYPE=3215,OFFLINE=NO,UIRATE=DEFAULT  
...
```

*Figure 102. Excerpt from REALVM DECK A*

Let us assume, there is no RDEVICE statement for device 1000 contained in file REALVM DECK A, but this device is defined for your processor POL1 configuration. If you also want to define this device for your operating system, you must define the missing device manually into your deck REALVM DECK A by adding the appropriate RDEVICE statement for device 1000.

Also, there may have been devices that had not been online at the time you ran the **CBDSRDEV** utility. Such devices are not defined in the current work IODF, because offline devices cannot be sensed by z/VM. You can now add these definitions to the OS configuration (REALVM). Therefore, you again add an appropriate RDEVICE statement for the missing device into your REALVM DECK A output file.

Now remigrate your completed REALVM DECK into your work IODF IODF71 WORKIODF A using partial migration (“Step 3. Migrate the z/VM IOCP into the Work IODF” on page 259):

```
cbdsmigr iodf71 workiodf a realvm deck a op realvm
```

## Step 6. Build the Production IODF

Now that you have created a correct and complete work IODF, it is recommended to save a backup of this file. Then use the REXX utility **CBDSPROD** to build the production IODF.

### Example:

```
cbdsprod iodf71
```

This is the shortest possible invocation of the **CBDSPROD** utility. It creates a production IODF called IODF71 PRODIODF A. If errors occur, these are written into the message log CBDSPROD MSGLOG A.

Check the severity of the error messages in the message log in column *Sev*:

- Informational messages are denoted by a letter **I**.
- Warnings are denoted by a letter **W**.
- Error messages are denoted by a letter **E**.

Check the messages and the user responses in *z/OS and z/VM Hardware Configuration Definition Messages*. You must correct the error messages, because otherwise, HCD cannot build a production IODF. For the information messages and the warnings, you can decide whether you want to change the IODF definitions. HCD builds a production IODF despite these messages, however, using the resulting configuration later may lead to undesired or unexpected results.

## Step 7. Build the IOCDS

With a correct production IODF, use the REXX utility **CBDSIOCP** to perform an IOCDS download to a specified IOCDS slot of a processor specified in the production IODF. Assume, we have one processor POL1 defined in the IODF, and we want to download the IOCDS to the support element into slot A0. The related command would be like follows:

```
cbdsiopc iodf71 prodiodf a poll i a0
```

## Step 8. Set Up the SYSTEM CONFIG File

The IODF statement in the SYSTEM CONFIG file indicates that HCD will be used to control the I/O hardware and/or software configuration.

### Syntax of the IODF statement

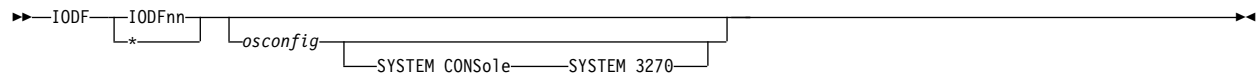

In the SYSTEM CONFIG file of z/VM, you specify which IODF and which z/VM configuration is to be used for IPL. The IODFnn PRODIODF file *must* be located on the same system parameter disk as the SYSTEM CONFIG file (default is the PMAINT CF0 disk).

The parameters in the IODF statement have the following meanings:

#### IODFnn

The file name of the production IODF. You must specify the name of a file of file type PRODIODF, and the file must be located on the system parameter disk (SYSPARM). If the correct IODF is not located on the system parameter disk, you may run into a 'disable wait problem' (see "Disable Wait Problem During IPL" on page 266).

- \* An \* specifies that the filename of the production IODF to be used is the one currently stored in the hardware configuration token in the HSA. The matching IODF must be located on the system parameter disk (SYSPARM) at the system IPL time. In our example filelist shown hereafter, the IODF name is **IODF71**.

Filename	Filetype	Fm	Format	Lrecl	Records
SYSTEM	CONFIG	B1	F	80	272
IODF19	PRODIODF	B6	F	4096	184
SNAZ	LOGO	B1	F	78	16
PRINTZ	LOGO	B1	F	78	16

LOCALZ	LOGO	B1 F	78	16
LDEVZ	LOGO	B1 F	78	16
<b>IODF71</b>	<b>PRODIODF B6 F</b>		<b>4096</b>	<b>7000</b>
CPLoad	MODULE	B1 V	65535	149
CPLold	MODULE	B1 V	65535	149

The following specifications are only applicable if HCD also controls the software I/O configuration.

**osconfig**

specifies the OS configuration ID of the VM I/O configuration that is defined in the IODF. This OS configuration should be controlled with HCD. If specified, this configuration is used to build the software view of the I/O configuration, and the statements that are normally used in the system configuration file to build this view are ignored.

**SYSTEM\_CONSOLE**

specifies that the Operating System Messages panel on the IBM Hardware Management Console (HMC) can serve as a system operator console.

**SYSTEM\_3270**

specifies that the integrated 3270 console on the HMC can serve as a system operator console.

*Example of an IODF statement:*

```
IODF IODF71 REALVM
```

## Step 9. Perform a Power on Reset (POR)

On the HMC (Hardware Management Console), go to *Customize Activation Profiles*. Then, if you want to provide for dynamic configuration changes, be sure to adapt the *Reset Profile*. You enable dynamic changes by clicking on *Allow dynamic changes ...* (see Figure 103 on page 265).

Now you can perform a POR with slot A0.

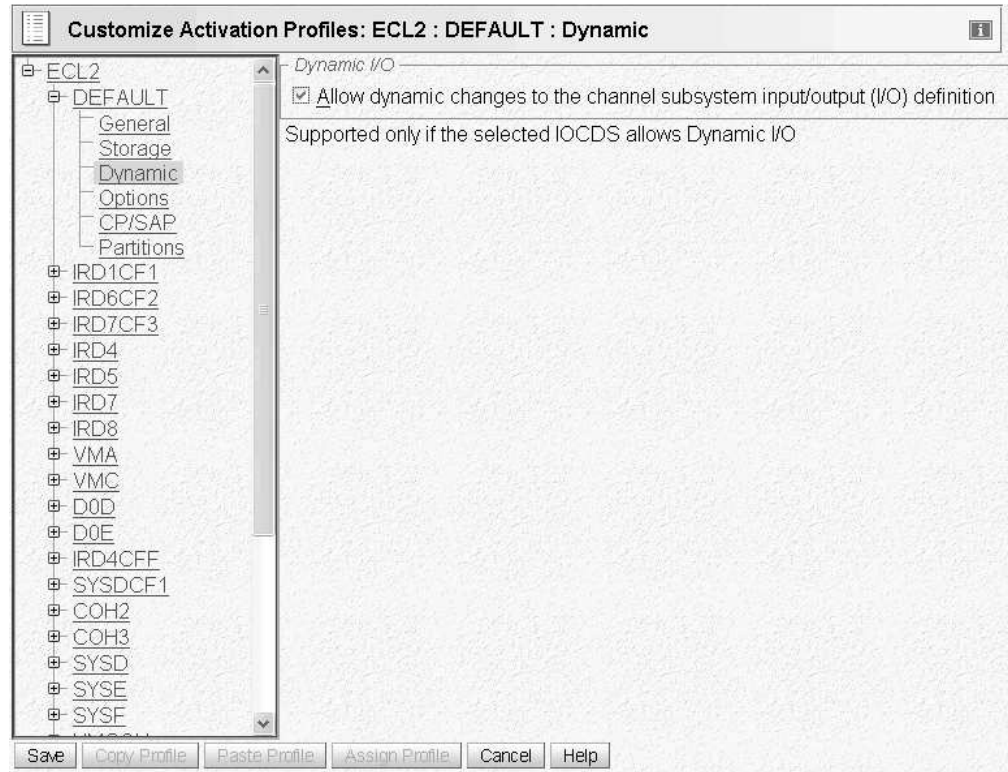

Figure 103. Customize Activation Profiles

## Step 10. Perform an Initial Program Load (IPL)

IPL your system. After IPL, type the `q hcd` command on your z/VM console to see the active IODF. In the example response, you can see that only dynamic HW changes are enabled and that HCD is not controlling the software configuration, because no `osconfig` parameter had been specified in the SYSTEM CONFIG file.

```
HCD is currently active: IODF = IODF71 PRODIODF
HCD is enabled for dynamic hardware changes
HCD is not controlling the software configuration
HCD recovery is not currently required
Ready; T=0.01/0.01 09:53:09
```

You can enter the `CP QUERY TOKEN` command to see the current or target configuration tokens:

```
q token current
```

```
The current HCD configuration token is:
POL1....m.o.....10-03-1007:50:15SYS4 IODF71
Ready;
```

```
q token target
```

```
The target HCD configuration token is:
POL1....m.o.....10-03-1007:50:15SYS4 IODF71
Ready;
```

**Note:** The HCD token does not contain VM-TOKEN. It contains the name of the processor (POL1) and of the production IODF (IODF71).

Go to the SE (Support Element), then go to *Input/Output (I/O Configuration)*. This screen shows the active IOCDs. Go to the tab, view *Dynamic*. On the *Dynamic Information* screen on the HMC console (Figure 104) you can check the configuration *Data set token* and the *Hardware system area token*. If HCD should be enabled for dynamic activation changes, both must be identical.

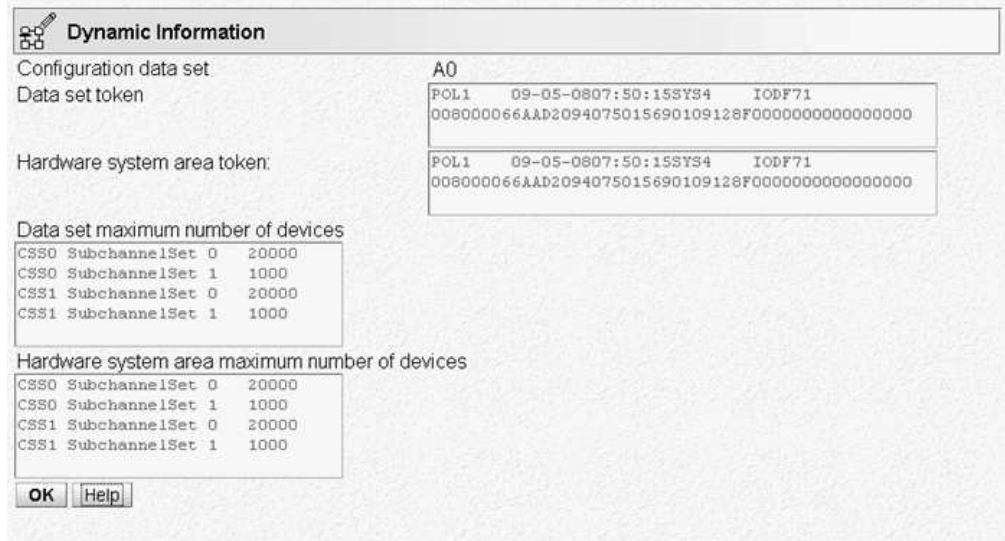

Figure 104. Information display from the support element

**Note:** Now your system is up and running according to your applied setup. As you provided for software and hardware changes, your system is also prepared for dynamic configuration changes. For more information, refer to topic *Activate a Configuration Dynamically* in *z/VM I/O Configuration*.

### Disable Wait Problem During IPL

A Disable Wait problem can occur if the IODF to be loaded is not on the system parameter disk.

### Disable Wait 9043

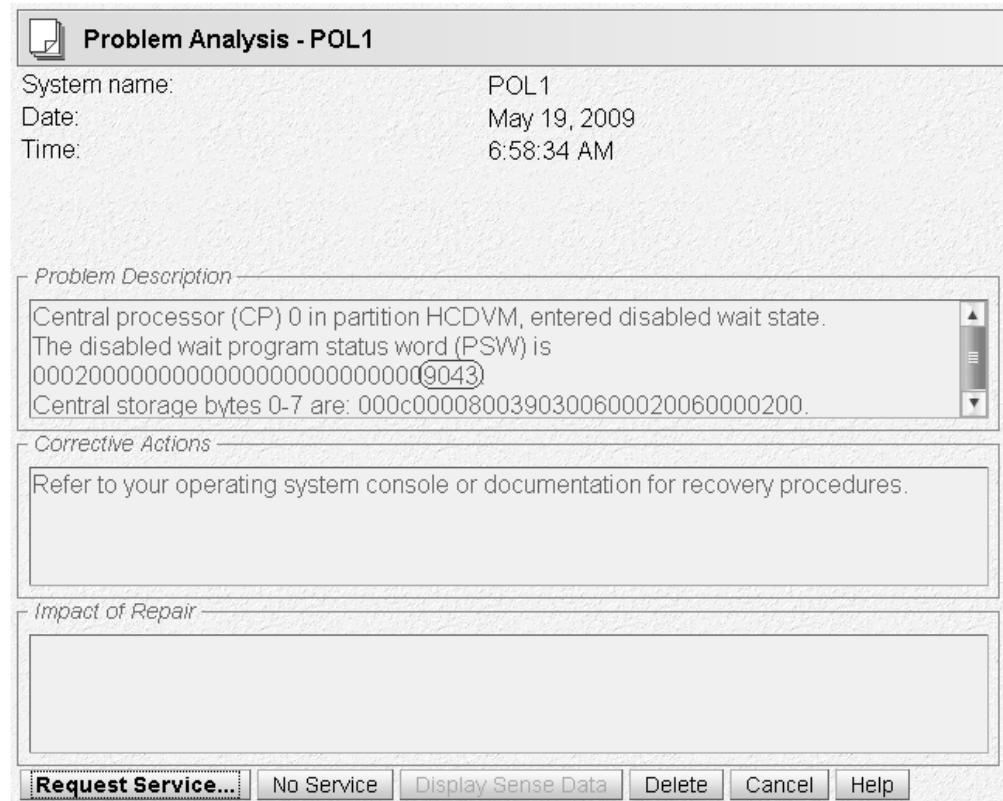

Figure 105. Disable Wait 9043

In this case, message HCP9043W provides the appropriate user response (see also in z/VM CP Messages and Codes):

#### HCP9043W Unable to process IODF file

**Explanation:** An IODF statement in the system configuration file was being processed during system initialization and one of the following errors was encountered:

- The specified IODF name is not valid.
- The IODF could not be opened.
- The IODF could not be read.
- The data in the IODF was not valid.
- An osconfig name was specified, but no matching OSR record was found in the IODF.

**System Action:** The system enters a disabled wait state (wait-state code = 9043).

**User Response:** Verify the validity of the IODF specified on the IODF system configuration file statement and re-IPL, or re-IPL using the NOHCD parameter on the SAPL screen to bypass the IODF system configuration file statement.

Verify that the IODFnn PRODIODF file is on the same system parameter disk as the SYSTEM CONFIG file (default is the PMAINT CF0 disk).

## Step 11. Load the Configuration into HCM

Now you are ready to run your normal configuration business. To manage your configuration with HCM, at this point in time, you can load your I/O configuration into HCM. Then you can explore your configuration by viewing the HCM configuration diagram and you can use the graphical HCM dialogs to apply logical and physical changes to your configuration. The logical changes are automatically propagated to the associated IODF on the host, for example, when adding new processors or devices. For detailed information refer to the *z/OS and z/VM Hardware Configuration Manager User's Guide*.

The normal workflow for applying configuration changes with HCM is like follows:

1. Create a new work IODF from your production IODF.
2. Apply your updates.
3. Check the results in the diagram or using the HCM functions to produce HCD textual reports.
4. Build the new production IODF.
5. With the production IODF, use the REXX utility **CBDSIOCP** to perform an IOCDS download to the processor.
6. Dynamically activate your changes as described in "Post-Migration Configuration Management with HCD."

## Post-Migration Configuration Management with HCD

Using HCD, you can now activate dynamic hardware and software changes in a running system configuration without the need to POR or IPL the system.

Perform the following steps:

1. Check, whether your system setup meets the prerequisites for performing dynamic hardware activation changes:  
Have a look at the tokens displayed in the screen shown in Figure 104 on page 266: the *Data set token* and the *Hardware system area token* must be identical.
2. Create a new work IODF based on your current production IODF:  
*If you are using HCM:*  
Select action *File ---> Make Work*  
*If you are not using HCM:*
  - a. Use the REXX utility **CBDSCONF** to produce a current IOCP deck from your production IODF. Specify the parameters for this utility depending on whether you want to make changes to the processor configuration or to the operating system.
  - b. Apply your changes to the generated IOCP deck. Then use REXX utility **CBDSMIGR** with parameter *IP* for partial migration to migrate the IOCP changes into your work IODF.
3. If you work with HCM you can now check the results in the configuration diagram or you can use the HCM functions to produce HCD textual reports.
4. Build the production IODF as described in "Step 6. Build the Production IODF" on page 262.
5. Use the **CBDSACT** REXX utility to test your specified changes without a real activation:  

```
CBDSACT IODF71 * * * (TEST
```

  
Then look for the result in file **CBDSACT MSGLOG**:

```

IODF71 PRODIODF A
Sev  Msgid  Message Text
I  CBDA126I  ACTIVATE IODF=71,CFID=ECL2,TEST command was accepted.
I  CBDD798I  The currently active IODF is IODF71 PRODIODF, the active
                configuration is ECL2.
                The HSA token is POL1 10-03-10 07:50:15 SYS4 IODF71.
I  CBDA781I  Your system configuration provides full dynamic
                reconfiguration capability.
I  CBDA887I  Following devices are to be added to processor POL1:
                2.2440-2.245F,2.0050-2.006F
I  CBDA884I  Following control units are to be added to processor POL1:
                2.2440,2.0050
I  CBDA881I  Following channel paths are to be added to processor POL1:
                2.16,2.D7
I  CBDD800I  All change requests were successfully executed.
Total Messages  Terminating  Error  Warning  Informational
                7                7
Return Code was  0

```

6. If everything is OK as desired, you need to issue the command again without the TEST option to really activate your changes.

If you control your z/VM software I/O configuration via HCD and you run multiple z/VM systems on *CPC2*, then your dynamic activation task consists of the following steps:

- Perform a software only change in all z/VM CPs except one.
- On the remaining z/VM system, perform a software and hardware change.

7. Copy the PRODIODF file to the system parameter disk (PARM disk). If needed, update the IODF statement in the SYSTEM CONFIG file. Keep a copy of the PRODIODF file that was written out to the IOCDS previously.

**Note:** The PRODIODF file should reside on the same PARM disk as the SYSTEM CONFIG file.

8. Use the REXX utility **CBDSIOCP** to perform an IOCDS download. This step is equivalent to “Step 7. Build the IOCDS” on page 263. There is no need for another POR or an IPL of the system.

**Note:** Now your system is again up and running with your applied changes and continues to be prepared for further dynamic configuration changes.

---

## Scenario 2: How to Migrate in a Mixed z/VM and z/OS Environment

A mixed z/VM and z/OS environment designates a customer installation where z/OS is running, but at least one CPC is running completely without z/OS, but with at least one z/VM system (*CPC2* in our example from Figure 106 on page 270). In such an environment, it is recommended to manage the z/VM system(s) running on this z/OS-free CPC also with z/OS HCD.

In this scenario, we start with an existing work IODF on one of the z/OS systems, containing just the *CPC1* configuration which we want to expand and use as the IODF for the complete environment. Therefore, we want to integrate the z/VM configurations from *CPC2* that does not run a z/OS system, into this IODF.

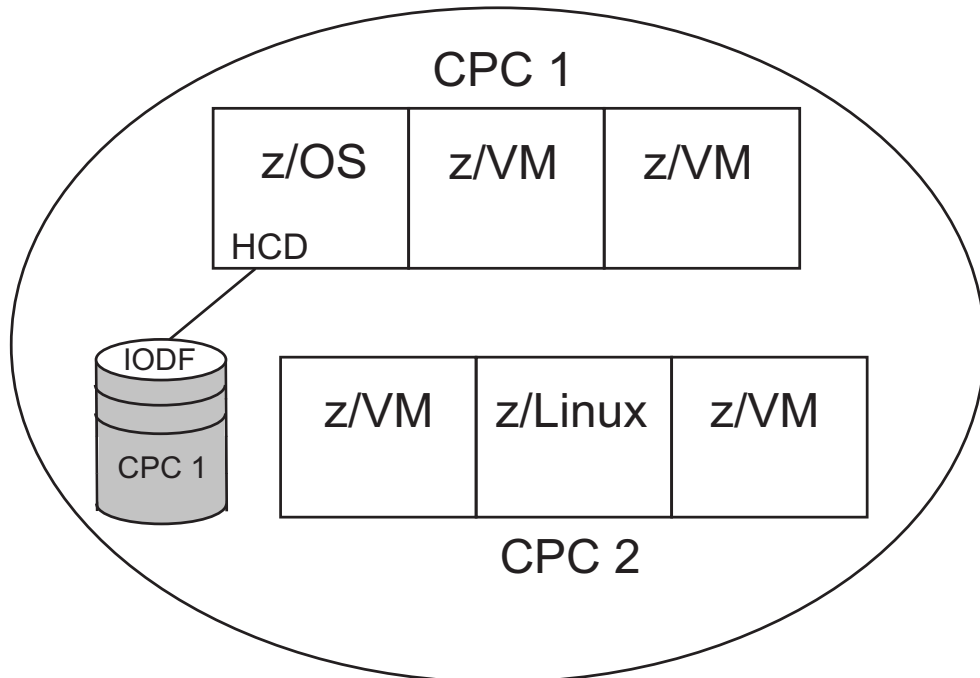

Figure 106. Mixed z/VM and z/OS Environment

In our scenario, we want to migrate the configuration of *CPC2* which is available as IOCP deck into the IODF located on *CPC1*.

Here is the list of steps to be performed:

- “Step 1. Migrate the z/VM IOCP into the Work IODF”
- “Step 2. Check your Configuration Specification” on page 271
- “Step 3. Integrate your Operating System(s) into the IODF” on page 271
- “Step 4. Build the Production IODF” on page 271
- “Step 5. Build the IOCDS” on page 271
- “Step 6. Set Up the SYSTEM CONFIG File” on page 272
- “Step 7. POR and IPL” on page 272
- “Post-Migration Configuration Management with HCD” on page 272

## Step 1. Migrate the z/VM IOCP into the Work IODF

We assume, that “Step 1. Prepare the IOCP deck for HCD” on page 256 has already been performed on the z/VM system. Therefore, you can now send the IOCP deck from *CPC2* to the z/OS system where the work IODF is located.

The current step 1 in our scenario is functionally equivalent to step 3 in scenario 1. However, in contrast to scenario 1, you can now use z/OS HCD to migrate this IOCP input file into the work IODF:

1. From the Primary Task Selection panel, select **5. Migrate configuration data**.
2. Then select **1. Migrate IOCP/OS data** from the **Migrate Configuration Data** task menu. This invokes the *Migrate IOCP / MVSCP / HCPRIO Data* dialog. See the *z/OS HCD User's Guide* or the online help for detailed information on how to use this dialog.

The IODF accessed by the HCD dialog on the *CPC1* z/OS system must be the work IODF currently containing the *CPC1* configuration. This is the target IODF for the migration of the *CPC2* configuration.

For information on how to transfer files between z/VM and z/OS, see “How to Exchange IODF or IOCP Files Between z/VM and z/OS” on page 273.

## Step 2. Check your Configuration Specification

At this point, you may again verify your changes with the help of the various HCD reports as described in “Step 5. Check Your Configuration Specification” on page 261. However, in the current scenario, you can use the HCD dialog to produce the reports. From the Primary Task Selection, select path 3.1:

1. *3. Print or compare configuration data*
2. *1. Print configuration reports*

## Step 3. Integrate your Operating System(s) into the IODF

This is an optional step and is only required if you want to use HCD to control the software (OS) configuration. In this case, perform the following steps:

1. From the Primary Task Selection Panel, select *1. Define, modify, or view configuration data*.
2. Then select *1. Operating system configurations*.
3. In the *Operating System Configuration List* define a new OS configuration of type *VM*. For more information, refer to the HCM User's Guide.
4. Now you can manually assign the required defined devices to the new operating system, starting from the *I/O Device List* as described in the HCD User's Guide.

Another possibility is to send the IODF to z/VM, then run the **CBDSRDEV** and **CBDSMIGR** utilities as described in “Step 4. Migrate Your Operating System from an RDEV List” on page 261. Then send the updated IODF back to the z/OS system.

## Step 4. Build the Production IODF

To generate a production IODF, select path 2.1 from the Primary Task Selection:

1. *2. Activate or process configuration data*
2. *1. Build production I/O definition file*

As the production IODF needs to be present on the system you want to manage, now transfer the production IODF to your z/VM system.

## Step 5. Build the IOCDs

For this step, you have two alternatives:

### *Alternative 1:*

If *CPC2* is managed via the Hardware Management Console, you can use path 2.11 of the z/OS HCD dialog to download the IOCP deck:

1. *2. Activate or process configuration data*
2. *11. Build and manage S/390 microprocessor IOCDs and IPL attributes*
3. From the *S/390 Microprocessor Cluster List*, select *CPC2*.
4. Select *1. Work with IOCDs*.

5. From the *IOCDS List*, use the '/' marker to select an unused IOCDS slot.
6. This brings up a selection of *Actions on selected IOCDSs*. Select **1. Update IOCDS**. In the upcoming *Build IOCDS* dialog, you do not need to perform any updates, but pressing PF3 just writes your IOCDS into the selected IOCDS slot. If you now select **2. Switch IOCDS**, this will update the IOCDS with all changes done to the IODF and will cause the system to automatically use this IOCDS for the next performed POR.

*Alternative 2:*

You perform the IOCDS download on the z/VM system on *CPC2*. This step is equivalent to “Step 7. Build the IOCDS” on page 263.

After this step, you can manage your complete environment (*CPC1* and *CPC2*) using the z/OS HCD dialog or using the HCM connected to *CPC1*.

## Step 6. Set Up the SYSTEM CONFIG File

This step is equivalent to “Step 8. Set Up the SYSTEM CONFIG File” on page 263 in Scenario 1.

## Step 7. POR and IPL

The remaining actions are equivalent to the steps in “Scenario 1: How to Migrate to HCD in a z/VM Environment Without z/OS” on page 255:

- “Step 9. Perform a Power on Reset (POR)” on page 264
- “Step 10. Perform an Initial Program Load (IPL)” on page 265

## Post-Migration Configuration Management with HCD

We assume, you now want to continue to manage your complete environment from a central point of control, using HCD on the z/OS system. This topic describes how to apply configuration changes, also dynamic ones, after you have completed the migration of the z/VM IOCP(s) into the central z/OS IODF of your environment. Basically, you apply your changes on z/OS and send the updated production IODF to z/VM.

1. Use the HCD ISPF dialog to create a new work IODF based on your current production IODF as described in the *z/OS HCD User's Guide*. Continue to use the HCD dialog to apply your configuration changes to the work IODF.
2. Build the production IODF under z/OS HCD: From the Primary Task Selection Panel, select **2. Activate or process configuration data**, then select **1. Build production I/O definition file**.
3. Transfer the production IODF to z/VM. To receive it on z/VM, use the CMS RECEIVE command or the **CBDSIMP** REXX utility.
4. Activate the new configuration using the **CBDSACT** REXX utility with the TEST option first and verify these are the changes you want. Then issue the **CBDSACT** REXX utility without the TEST option to perform the dynamic I/O changes.
5. COPY the PRODIODF file to the system parameter disk (PARM disk). If needed, update the IODF statement in the SYSTEM CONFIG file. Keep the old PRODIODF file on the disk as well. Thus, if the system is IPLed, it will pick up the latest production IODF.

**Note:** The PRODIODF file should reside on the same PARM disk as the SYSTEM CONFIG file.

6. Generate an IOCDs from the production IODF using the REXX utility **CBDSIOCP**. This will write out the IOCDs for next IML.

---

## How to Exchange IODF or IOCP Files Between z/VM and z/OS

In the scenarios previously described, you need to transfer files (data sets) between z/OS and z/VM. To achieve this task, you can select from the following alternatives:

- To transfer an IODF from z/OS to z/VM, you can use the z/OS HCD function **Export IODF**:
  1. From the Primary Task Selection Panel, select **6. Maintain I/O definition files**.
  2. Then select **5. Export I/O definition file** from the **Maintain I/O Definition Files** task menu. This invokes the **Export IODF** dialog where you specify the target z/VM node and user ID. HCD sends the IODF directly to z/VM where you receive the file on a CMS minidisk in a format known to z/VM and observing the IODF file naming conventions:

Filename: IODFxx  
Filetype: xxxxIODF

- You can transfer the IODF from z/OS to z/VM via FTP. First use the **Export IODF** dialog as described above and specify an asterisk (\*) for both the target user ID and node. This creates a sequential file on z/OS from the z/OS VSAM IODF data set using the following naming conventions:

`tsoid.EXPORTED.iodefname`

where:

**tsoid**

is the sending TSO user ID or the TSO prefix, (or is determined by the profile option `EXPORTED_HLQ`)

**iodefname**

is the part of the IODF data set name after the high-level qualifier.

**Example:**

`DOCU.EXPORTED.IODFCC.WORK`

Now you can send this file to z/VM using FTP. (Use type **i** for binary.)

- To transfer an IODF from z/VM to z/OS, use the CMS `SENDFILE` command or the **CBDSEXP** REXX utility.

If you want to view your z/OS IODF data set from a zVM system, you can share a volume between z/OS and z/VM. Export the z/OS IODF data set into a sequential file and place it on this shared disk. Then you can look at it from z/VM.

Here are the steps for exporting the IODF and installing the shared DASD:

1. Bring up the z/OS guest on z/VM.
2. Invoke HCD and use option **6.5 Export I/O definition file**.
3. Vary the device offline: `v xxxx,OFFLINE` (`xxxx` denotes the device number of the shared DASD).
4. Detach `xxxx` from z/OS
5. Then on z/VM:  
`ATTACH xxxx * R/O`  
or link to the appropriate full-pack minidisk to get access to the shared volume that contains the z/OS sequential dataset.

6. ACCESS xxxx T
7. LISTDS T shows the files
8. FILEDEF IODFIN T DSN userid.exported.iodf01 (DSORG PS
9. FILEDEF IODFOUT DISK IODF01 IODF A
10. MOVEFILE IODFIN IODFOUT

**Note:** The CMS FILE IODF01 IODF A should be re-named to IODF01 WORKIODF A or IODF01 PRODIODF A for use by z/VM HCD.

---

## Part 3. Using Dynamic I/O Configuration

This part describes dynamic I/O configuration planning.

Before installation of z/VM, you need to plan:

- What the processor and device configuration will be
- What z/VM functions the system will use
- Which guest operating systems will be used
- How much storage will be required
- What sort of user environments will be available.

During system generation, you will set the proper parameters in the system to implement your plan for the system. Later, after the system is running, you will want to change some of these parameters as conditions change; for example, when new users are allowed access to the system and new devices are brought online. You will also want to monitor the performance of the system and perhaps change tuning parameters to make it run more efficiently.

A good example of the overlap between planning and administration is the user directory. The user directory is a file that identifies each user on the system and contains control statements that define the environment each user works under. Initially, you will set up this directory for the known users of the system. Later, as new users are given access to the system and others are removed, you will have to update the directory.

The following list describes I/O configuration tasks you may need to perform and where you can find information to help you complete each task:

- Define the IOCDS, which is the data set that defines the I/O configuration for the hardware, and write it to the hardware processor controller. See the *3090 Input/Output Configuration Program User's Guide and Reference* book.
- **Define all real I/O devices** using one of the following:
  1. Dynamic device sensing and the system configuration file.
  2. Real I/O configuration file, HCPRIO ASSEMBLE.  
For information on devices supported, see *z/VM: CP Planning and Administration*.
- **Define virtual machine I/O devices in the user directory.** As part of each user's virtual machine directory entry, you can code that virtual machine's I/O configuration. Use the following directory control statements to define a virtual machine I/O configuration:
  - DEDICATE—specifies that a virtual machine has exclusive use of a real I/O device. For example, if you dedicate a printer to a virtual machine, the virtual machine has exclusive use of a real printer.
  - SPOOL—defines a spooled unit record device for a virtual machine. In contrast with the DEDICATE statement, if you use the SPOOL statement to define a unit record device for a virtual machine, the virtual machine does *not* have exclusive use of a real unit record device. Rather, CP shares real unit record devices among virtual machines that have spooled unit record devices.
  - CONSOLE—defines a virtual machine operator's console.

- SPECIAL—defines a virtual display, communication line, or channel-to-channel adapter for a virtual machine.
- MDISK—defines a minidisk for a virtual machine.
- LINK—defines a connection or link to another user's minidisk.

For more information on these and other directory control statements, see *z/VM: CP Planning and Administration*.

---

## Chapter 16. Introduction to the Dynamic I/O Configuration Facility

This chapter describes the various parts of your I/O configuration, how they interact, and how you can use dynamic I/O configuration to change them.

---

### What is an I/O Configuration?

Your processor's I/O configuration is comprised of the:

- Channel paths on your processor complex
- Control units attached to the channel paths
- I/O devices assigned to the control units.
- Logical partitions

In the processor, the channel subsystem (CSS) uses information about your I/O configuration to direct the flow of information between I/O devices and main storage, relieves the processor of communication tasks, and performs path management functions.

Once your z/VM system is up and running, there will be occasions where you want to change your I/O configuration. On a z/VM system that does not support dynamically changing the I/O configuration (that is, before VM/ESA® Version 2 Release 1.0), you would have to perform the following steps for your I/O configuration changes to take effect:

1. Update the I/O configuration program (IOCP) source file,
2. Download the I/O configuration to the support element (SE) using the IOCP utility,
3. Shutdown z/VM (the operating system),
4. Perform a power-on reset (POR) of the hardware, and
5. Perform an initial program load (IPL) of the software

**Note:** If your processor is in logically partitioned (LPAR) mode and one of the logical partitions is running z/OS, you can dynamically change the I/O configuration using the Hardware Configuration Definition\* (HCD\*) component. However, you cannot use the z/VM and z/OS dynamic I/O configuration facilities simultaneously. You must decide whether z/VM or z/OS will be dynamically changing the I/O configuration.

---

### What Is Dynamic I/O Configuration?

Dynamic I/O configuration is a facility in the processor's licensed internal code (LIC) that allows you to change your I/O configuration without requiring a system outage (POR and IPL). Using the z/VM dynamic I/O configuration facility, you can add, delete, or modify the definitions of channel paths, control units, and I/O devices to both the hardware and software.

### Where Is the I/O Configuration Information Stored?

Before you begin changing your I/O configuration dynamically, you should understand how and where your I/O configuration is defined. Your system's hardware and software each have their own "view" of what the I/O configuration looks like.

#### The Hardware View

The hardware gets its initial view of the I/O configuration from the active I/O configuration data set (IOCDS) file stored in the support element (SE). The active IOCDS file is created by:

1. Defining your I/O configuration to IOCP using IOCP macroinstructions. (For more information about the IOCP macroinstructions, see the IOCP manual of your specific processor.
2. Issuing the IOCP utility to build an IOCDS file from your IOCP macroinstructions and to write the IOCDS file onto the support element (SE) hard disk. (You can have 4 to 12 different IOCDS files stored on the support element hard disk, depending on the type of processor complex you have, but only one can be the active IOCDS file.)
3. Performing a power-on reset (POR) to make the new IOCDS file active.

The channel subsystem (CSS) takes a snapshot of the IOCDS file at power-on reset time and stores it in the hardware system area (HSA). The information stored in the HSA directs the flow of information between the I/O devices and main storage.

#### The Software View

The software gets its view of the I/O configuration at system initialization (IPL). There are several ways for z/VM to build its view of the I/O configuration:

1. **Dynamically** — using information from any combination of device sensing, device initialization, and RDEVICE statements specified in the system configuration file (SYSTEM CONFIG) on the parm disk.
2. **Statically** — by specifying RDEVICE macroinstructions for each I/O device in the real I/O configuration file (HCPRIO ASSEMBLE) in the CP nucleus.
3. Some combination of the first two.

#### Important Note for HCPRIO and HCPSYS Users

All future device and system definition additions, changes, and enhancements will only be made to the system configuration file. This means that you will still be able to use HCPSYS and HCPRIO, but only as you used them in earlier releases. Any new function added to the device and system definition arena will only be available to you through the system configuration file.

---

### What Can I Do with Dynamic I/O Configuration?

Using dynamic I/O commands, you can:

- Add:
  - Channel paths to your processor complex
  - Control units attached to channel paths
  - I/O devices assigned to control units
  - Logical partitions

- Delete:
  - Channel paths from your processor complex
  - Control units from their assigned channel paths
  - I/O devices from their assigned control units
  - Logical partitions
- Modify existing:
  - Channel paths in your processor complex
  - Control units attached to channel paths
  - I/O devices assigned to control units
- Switch the active IOCDs file so that it will be used during the next POR
- Implement CPC-wide (Central Processing Complex) changes in an LPAR environment.

---

## What to Expect from These Chapters

The chapters that follow will describe how you can plan for, install, create, and modify an I/O configuration. These chapters also take into account the steps involved in planning and installing an I/O configuration for a new z/VM system or an existing z/VM system.

### A Note About the Examples

In Chapter 20, “Planning an I/O Configuration,” on page 299, Chapter 22, “Using VM Dynamic I/O Configuration,” on page 313, and Chapter 24, “Sample I/O Configuration Program File,” on page 331, there are examples of 3990 storage controllers. In all these examples, the 3990 storage controllers are running in device level selection enhanced (DLSE) mode and show the 3990 subsystems defined using a single CNTLUNIT macroinstruction. When using a single CNTLUNIT macroinstruction for DLSE-mode 3990s, the order of the channel paths in the PATH parameter is important. For proper rotation of channel path selection, you should connect adjacent channel path identifiers (CHPIDs) in the PATH parameter to different storage directors within the 3990 storage controllers. That is, the first CHPID should be a path to storage-director 1 (SD-1), the second CHPID should be to SD-2, the third to SD-1, and the fourth to SD-2. This ordering of CHPIDs on the PATH parameter of a single CNTLUNIT macroinstruction is functionally equivalent to the definition using two CNTLUNIT macroinstructions (one for each SD) that is described as being required in the *3990 Storage Control Planning, Installation, and Storage Administration Guide*, GA32-0100.



---

## Chapter 17. Understanding Hardware Configuration

This chapter shows how dynamic I/O configuration takes place on a z/VM system with processors running in logically partitioned (LPAR) mode, with both the hardware and software (operating system) supporting dynamic I/O configuration changes.

---

### Understanding LPAR Mode

Your z/VM system runs on hardware that can be configured only in logically partitioned (LPAR) mode, in which the hardware is configured (or “divided”) into logical partitions (LPs). Each logical partition (LP) is configured to run one operating system. Thus, the hardware can run more than one operating system by having more than one LP.

Enterprise Systems Connection (ESCON<sup>®</sup>) Multiple Image Facility (EMIF), available on all currently supported processors, further allows multiple logical partitions to share channel paths.

**Note:** You can share only the following types of channel paths:

- CBP
- CBS
- CFP
- CFS
- CNC
- CTC
- DSD
- EIO
- FC
- FCP
- FCV
- ICP
- IQD
- ISD
- OSA
- OSC
- OSD
- OSE
- OSM
- OSN
- OSX

The logical channel subsystem (LCSS) facility introduced a channel subsystem structure in which the definition of multiple logical channel subsystems is allowed, providing channel path and subchannel controls for configuring from one to four channel subsystem images on a processor. Each channel subsystem image can be configured with up to 256 channel paths and each logical partition has access to one channel subsystem image. z/VM's dynamic I/O commands allow the capability for channel paths, control units, devices, and logical partitions to be dynamically added, modified, and deleted in an LCSS environment.

Real I/O hardware is attached to a processor via physical channels. Physical channels have a physical channel identifier (PCHID) which determines the physical

## Before Dynamic I/O

location of a channel path in the processor. When dynamically defining a logical channel path (CHPID) with the DEFINE CHPID command, you must specify the PCHID associated with the CHPID being defined (unless the CHPID is an internal CHPID type).

**Note:** Some types of channel paths can be shared across partitions belonging to different channel subsystems. Such a channel is called a spanned channel path.

For more information refer to the *z/OS and z/VM: Hardware Configuration Manager User's Guide* and to the *IOCP User's Guide* that is appropriate for your processor.

---

## How Does the Hardware Get Its View of the I/O Configuration?

Now that you know something about the operational modes of the hardware, you need to understand how the hardware gets its information about the I/O configuration. The hardware gets its view of the I/O configuration when you:

- Define the I/O configuration in the IOCP source file,
- Write the new I/O configuration to disk using the IOCP utility,
- Select the new I/O configuration as the active configuration, and
- Bring the new I/O configuration online by performing a power-on reset (POR).

## Defining the Hardware I/O Configuration

To create the hardware's view of the I/O configuration, you must define all of the channel paths, control units, I/O devices, and logical partitions in the IOCP source file using the following IOCP macroinstructions:

### CHPID

A required macroinstruction that defines the channel paths installed on the central processor complex (CPC).

### CNTLUNIT

A required macroinstruction that defines the control units attached to the channel paths installed on the CPC.

### IODEVICE

A required macroinstruction that defines the I/O devices assigned to the control units attached to the channel paths installed on the CPC.

Also, there are a few other optional macroinstructions that you should include:

**ID** An optional macroinstruction that specifies the identification information to be printed in the heading of IOCP configuration reports.

### RESOURCE

An optional macroinstruction that defines:

- Logical partition names
- MIF image ID numbers assigned to the logical partitions
- Logical channel subsystems (CSSs)
- The maximum number of devices that can be dynamically defined for a dynamic-capable IOCDs
- Reserved logical partitions for a dynamic-capable IOCDs.

Chapter 24, "Sample I/O Configuration Program File," on page 331 contains a sample IOCP source file. For more information about using the IOCP macroinstructions, see the IOCP manual of your specific processor.

## Writing the Hardware I/O Configuration to Disk

After the IOCP source file is created, the IOCP utility must write the IOCDS file to the hardware (the hard disk of the support element). For more information, consult the IOCP manual of your specific processor.

## Bringing the Hardware I/O Configuration Online

After writing the IOCDS file to the hardware, you need to select the IOCDS file and perform a power-on reset (POR) to bring the I/O configuration online. The method used to perform the POR is processor dependent.

For more information on performing a POR, consult the operator's guide that documents your processor.

After you perform a power-on reset (POR) of the processor, you must perform an initial program load (IPL) of the operating system to create the software's view of the I/O configuration.

---

## Creating the z/VM I/O Configuration

When you perform an initial program load (IPL) of z/VM, z/VM creates its view of the software I/O configuration. If the I/O devices support the E4 sense ID channel command word (CCW) and the sense ID request returns all the information z/VM needs about those I/O devices, z/VM can get all the information it needs to build the software's view of the I/O configuration during system initialization and when an I/O device is varied online or initialized. z/VM stores this information in various control blocks, such as the real device control block (RDEV). In most cases, z/VM will IPL without requiring any more information about the I/O devices.

On older releases of z/VM, the hardware I/O configuration would be static at this point, with no ability to add, delete, or modify any channel paths, control units, or I/O devices without causing a system outage. Current releases of z/VM are designed to minimize these outages by taking advantage of a hardware facility called Dynamic I/O Configuration.



---

## Chapter 18. Understanding Dynamic Configuration in z/VM

This chapter gives you an overview of the dynamic I/O configuration functions available in z/VM. There are dynamic I/O configuration functions available to you in both the hardware and the software (z/VM).

Using the dynamic I/O configuration functions, you can add, delete, and modify channel path, control unit, I/O device, and logical partition definitions dynamically.

---

### Hardware Functions

First, suppose we take a look at the dynamic I/O configuration functions that are available to you in the hardware.

#### Channel Path Definitions

The hardware provides the following dynamic I/O configuration functions for channel paths:

- Defining new channel paths installed on the processor
- Deleting existing channel paths installed on the processor (as long as **all** control units attached to the channel paths were previously deleted)
- Making changes to the existing channel paths installed on the processor:
  - Adding access to a channel path from one or more logical partitions
  - Deleting access to a channel path from one or more logical partitions:
    - Unconditionally
    - Only if the channel path is not presently in use and configured to one of the logical partitions
  - Adding access to a channel path from a channel-subsystem image
  - Deleting access to a channel path from a channel-subsystem image
- Redefining (dynamically) channel paths by deleting them and then defining them again.

**Important Note:** Before deleting an existing channel path, you must delete or disassociate the control units assigned to that channel path.

#### Control Unit Definitions

The hardware provides the following dynamic I/O configuration functions for control units:

- Adding new control units (CUs) attached to the channel paths installed on the processor
- Deleting existing control units attached to the channel paths installed on the processor (as long as **all** I/O devices assigned to the control units were previously deleted)
- Making changes to the existing control units attached to the channel paths installed on the processor by:
  - Adding additional channel paths
  - Adding additional unit addresses
  - Deleting existing channel paths

## z/VM Functions

- Deleting existing unit addresses
- Changing the control unit interface to ESCON
- Changing the link addresses
- Changing the control unit logical address
- Changing the maximum number of managed paths that can be attached to the control unit
- Adding channel-subsystem image access
- Deleting channel-subsystem image access.

**Important Note:** Before deleting an existing control unit, you must delete or disassociate all the I/O devices assigned to that control unit.

## I/O Device Definitions

The hardware provides the following dynamic I/O configuration functions for I/O devices:

- Adding new I/O devices assigned to the control units attached to the channel paths installed on the processor
- Deleting existing I/O devices assigned to the control units attached to the channel paths installed on the processor
- Making changes to the existing I/O devices assigned to the control units attached to the channel paths installed on the processor by:
  - Adding access to control units
  - Adding access to one or more logical partitions
  - Deleting access to control units
  - Deleting access to one or more logical partitions
  - Declaring a preferred channel path
  - Declaring whether this I/O device is a DASD
  - Disabling the I/O interface time out function
  - Disabling the status verification facility
  - Enabling the I/O interface time out function
  - Enabling the status verification facility

**Important Note:** Before deleting an existing I/O device, that I/O device must be offline to z/VM and subchannel disabled (subchannel offline) to the processor.

## Logical Partition Definitions

The hardware provides the following dynamic I/O configuration functions for logical partitions:

- Adding new logical partitions.

**Important Note:** In order to add logical partitions, you must first predefine one or more reserved logical partitions by using the RESOURCE statement in your IOCP, specifying an '\*' for the partition name.

After defining the LPAR, go to the HMC and define an LP activation profile. Note that activating the new LP should automatically bring online all of the CHPIDs defined in the initial access list for the new LP. Then IPL your new LPAR.

- Deleting logical partitions.

**Important Note:** In order to delete a logical partition, you must first disconnect it from the rest of the I/O configuration so that it is no longer an active partition. After successfully deleting a logical partition, it becomes a reserved partition.

**Keep in mind the following considerations when dynamically adding or deleting logical partitions:**

- You cannot dynamically delete an active logical partition from the I/O configuration.
- After you assign a name to a partition, you can assign dedicated CHPIDs for that partition and add the partition to the candidate lists of any reconfigurable, shared, or spanned CHPIDs.
- Before deleting a logical partition from the I/O configuration by unassigning the partition name, you must unassign any dedicated CHPIDs defined for the partition. If there are any reconfigurable, shared, or spanned CHPIDs defined for the partition, you must remove the partition name from the candidate list for those CHPIDs.
- When you delete a logical partition from the I/O configuration dynamically, you do not have to delete the partition from each device's candidate list, unless you used an explicit candidate list when you defined the device.

## Switching the Active IOCDS File

With dynamic I/O configuration the hardware provides the capability of selecting the I/O configuration data set (IOCDS) file the support element (SE) should use as the active one. The SE uses the active IOCDS file during the next initial machine load (IML) or power-on reset (POR) to build the hardware's view of the I/O configuration.

---

## Software Functions

Several specific CP commands allow authorized users to dynamically change z/VM's view and the channel subsystem's view of the I/O configuration of the processor. Using the dynamic I/O configuration functions in z/VM, you can use these CP commands to add, delete, and modify the definitions of channel paths, control units, and I/O devices. For complete descriptions of these CP commands, see the *z/VM: CP Commands and Utilities Reference*.

## Channel Path Definitions

Using the following dynamic I/O commands, you can change the hardware's and the software's view (z/VM's view) of the channel paths in the I/O configuration.

When You Are ...	Use These Dynamic I/O Commands
Defining new channel paths installed on the processor	DEFINE CHPID DEFINE PATH
Deleting existing channel paths installed on the processor (as long as <b>all</b> control units attached to the channel paths were previously deleted)	DELETE CHPID DELETE PATH

When You Are ...	Use These Dynamic I/O Commands
Making changes to the existing channel paths installed on the processor: <ul style="list-style-type: none"> <li>• Adding access to a channel path from one or more logical partitions</li> <li>• Deleting access to a channel path from one or more logical partitions:               <ul style="list-style-type: none"> <li>– Unconditionally</li> <li>– Only if the channel path is not presently in use and configured to one of the logical partitions</li> </ul> </li> <li>• Adding access to a channel path from a channel-subsystem image</li> <li>• Deleting access to a channel path from a channel-subsystem image</li> </ul>	MODIFY CHPID MODIFY PATH
Redefining (dynamically) channel paths by deleting them and then defining them again.	DELETE CHPID DELETE PATH
Making changes to the existing control units attached to the channel paths installed on the processor by: <ul style="list-style-type: none"> <li>• Adding additional channel paths</li> <li>• Deleting existing channel paths.</li> </ul>	MODIFY CU MODIFY CNTLUNIT
Making changes to the existing I/O devices assigned to the control units attached to the channel paths installed on the processor by: <ul style="list-style-type: none"> <li>• Declaring a preferred channel path</li> </ul>	MODIFY DEVICE MODIFY IODEVICE

**Important Note:** Before deleting an existing channel path, you must delete or disassociate the control units assigned to that channel path.

## Control Unit Definitions

Using the following dynamic I/O commands, you can change the hardware's and software's view (z/VM's view) of the control units in the I/O configuration.

When You Are ...	Use These Dynamic I/O Commands
Adding new control units (CUs) attached to the channel paths installed on the processor	DEFINE CU DEFINE CNTLUNIT
Deleting existing control units attached to the channel paths installed on the processor (as long as <b>all</b> I/O devices assigned to the control units were previously deleted)	DELETE CU DELETE CNTLUNIT

When You Are ...	Use These Dynamic I/O Commands
Making changes to the existing control units attached to the channel paths installed on the processor by: <ul style="list-style-type: none"> <li>• Adding additional channel paths</li> <li>• Adding additional unit addresses</li> <li>• Deleting existing channel paths</li> <li>• Deleting existing unit addresses</li> <li>• Changing the control unit interface to ESCON</li> <li>• Changing the link addresses</li> <li>• Changing the control unit logical address</li> <li>• Changing the maximum number of managed paths that can be attached to the control unit</li> <li>• Adding channel-subsystem image access</li> <li>• Deleting channel-subsystem image access.</li> </ul>	MODIFY CU MODIFY CNTLUNIT
Making changes to the existing I/O devices assigned to the control units attached to the channel paths installed on the processor by: <ul style="list-style-type: none"> <li>• Adding access to control units</li> <li>• Deleting access to control units.</li> </ul>	MODIFY DEVICE MODIFY IODEVICE

**Important Note:** Before deleting an existing control unit, you must delete or disassociate all the I/O devices assigned to that control unit.

## I/O Device Definitions

Using the following dynamic I/O commands, you can change the hardware's and software's view (z/VM's view) of the I/O devices in the I/O configuration.

When You Are ...	Use These Dynamic I/O Commands
Adding new I/O devices assigned to the control units attached to the channel paths installed on the processor	DEFINE DEVICE DEFINE IODEVICE
Deleting existing I/O devices assigned to the control units attached to the channel paths installed on the processor	DELETE DEVICE DELETE IODEVICE
Making changes to the existing I/O devices assigned to the control units attached to the channel paths installed on the processor by: <ul style="list-style-type: none"> <li>• Adding access to control units</li> <li>• Adding access to one or more logical partitions</li> <li>• Deleting access to control units</li> <li>• Deleting access to one or more logical partitions</li> <li>• Declaring a preferred channel path</li> <li>• Declaring whether this I/O device is a DASD</li> <li>• Disabling the I/O interface time out function</li> <li>• Disabling the status verification facility</li> <li>• Enabling the I/O interface time out function</li> <li>• Enabling the status verification facility</li> </ul>	MODIFY DEVICE MODIFY IODEVICE

**Important Note:** Before deleting an existing I/O device, that I/O device must be offline to z/VM and subchannel disabled (subchannel offline) to the processor.

### Logical Partition Definitions

Using the following dynamic I/O commands, you can change the hardware's and software's view (z/VM's view) of the logical partitions in the I/O configuration.

When You Are ...	Use These Dynamic I/O Commands
Adding new logical partitions. <b>Note:</b> In order to add logical partitions, you must first predefine one or more reserved logical partitions by using the RESOURCE statement in your IOCP, specifying an '*' for the partition name.	DEFINE LPAR
Deleting existing logical partitions. <b>Note:</b> In order to delete a logical partition, you must first disconnect it from the rest of the I/O configuration so that it is no longer an active partition. After successfully deleting a logical partition, it becomes a reserved partition.	DELETE LPAR

### Switching the Active IOCDS File

Using the dynamic I/O command SET IOCDS\_ACTIVE, you can define which IOCDS file the processor will use as the active one. The processor uses the active IOCDS file during the next initial machine load (IML) or power-on reset (POR) to build the hardware's view of the I/O configuration.

For a complete description of the SET IOCDS\_ACTIVE command, see the *z/VM: CP Commands and Utilities Reference*.

---

## Chapter 19. Migrating to Dynamic I/O Configuration

This chapter describes how to get your z/VM system ready to dynamically change your I/O configuration. When you change your I/O configuration, you must change both the hardware's view and the software's view of the I/O configuration. This will involve making changes to your IOCP source file and, possibly, your system configuration file.

Also, this chapter introduces you to the two philosophies of making dynamic I/O configuration changes: “plug 'n' play” and “lock-step”.

---

### Dynamic I/O Terminology

Before we talk about migration, it might be a good idea to review some of the terms you will be seeing throughout this chapter:

#### **dynamic I/O configuration**

A facility in the processor's licensed internal code (LIC) that lets you change your I/O configuration without requiring a system outage. In other words, you can create a new I/O configuration without performing a power-on reset (POR) of the hardware and an initial program load (IPL) of the software. Dynamic I/O configuration enables you to add, delete, or modify the definitions of channel paths, control units, and I/O devices to both the hardware and software. When dynamic I/O configuration is used with software that supports it, that software can adapt to I/O changes initiated elsewhere.

**Note:** You may hear or see the dynamic I/O configuration function referred to as:

- Dynamic I/O reconfiguration
- Dynamic I/O
- Dyn I/O.

#### **configuration mode**

A hardware state that allows you to dynamically change your I/O configuration without requiring a system outage (POR and IPL).

#### **configuration token**

The hardware and software I/O configurations stay synchronized using configuration tokens when making dynamic I/O changes. We refer to these tokens as the “hardware configuration token” and the “VM configuration token”.

The hardware configuration token is created when you use the IOCP utility with the DYN option to generate a new I/O configuration data set (IOCDS) file. This token is static. That is, once created, the token in the IOCDS can only be changed by generating a new IOCDS file.

The VM configuration token is not static. The string value of a VM configuration token starts out identical to the hardware configuration token. The VM configuration token changes when:

- A dynamic I/O configuration change has completed,
- You initial machine load (IML) the processor, or
- You power-on reset (POR) the processor.

## Migrate to Dynamic I/O

The configuration tokens have two forms:

- The “current token” is a string value associated with the present I/O configuration
- The “target token” is a string value associated with the I/O configuration after a dynamic I/O configuration change has completed.

The VM configuration token is stored in the z/VM system common area. (Users never see or create the configuration tokens in this area.) Hardware configuration tokens are stored in two places: the IOCDS file and the hardware system area (HSA).

The hardware and VM configuration tokens become mismatched (out of sync) when:

- CP is processing a dynamic I/O command, and a hardware or software failure occurs
- Another logical partition changes the hardware configuration token.

---

## Preparing to Dynamically Change Your I/O Configuration

Because the dynamic I/O configuration function is a fairly recent enhancement (both to the hardware and the software), it is not the default method of changing your I/O configuration. That is, there are a few changes you must make to the hardware and software before you can make changes to your I/O configuration dynamically.

### Recommendation

Although you can make the changes to the hardware and software in tandem, we **strongly** recommend that you make the changes to the hardware, before making the changes to the software.

## Enabling Dynamic I/O in the Hardware

This section describes all of the changes you need to make on the hardware side before you can dynamically change your I/O configuration. Where possible, we have given detailed instructions. However, please note that each processor model has its own method of accomplishing certain tasks (for example, power-on reset). You may find it necessary to consult the operator's guide that documents your processor for detailed instructions on how to accomplish certain tasks.

### Important

If you are running with more than one operating system capable of making dynamic I/O changes (z/VM and z/OS), be aware that both operating systems can change their view of the I/O configuration *as well as* the hardware's view of the I/O configuration, but not simultaneously.

Allowing multiple operating systems in multiple logical partitions to dynamically change their view (the software's view) of the I/O configuration is not a problem. However, if you allow operating systems in more than one logical partition to dynamically change the hardware's view of the I/O configuration, you will have no central point of control and may begin to experience multiple operational problems. These operational problems may include lost or incomplete I/O transactions.

Therefore, we **strongly** recommend that you have the z/VM and z/OS personnel meet to decide which group will control the changes to the hardware I/O configuration. The other operating system will only make changes to the software's I/O configuration.

If you have z/OS controlling the hardware's I/O configuration, z/VM will only control its view of the software I/O configuration. This means you cannot use any of the dynamic I/O commands in the *z/VM: CP Commands and Utilities Reference* (except for the SET DEVICES command) to change your software I/O configuration. Instead, you will have to:

- Create or change real device control blocks (RDEVs) using CP SET RDEVICE commands or RDEVICE statements in your system configuration file.
- Bring the devices online or offline using the CP VARY command.

If you have z/VM controlling the hardware's I/O configuration, z/OS or the other z/VM system will only control its view of the software I/O configuration. For z/OS, this will probably involve using the Hardware Configuration Definition (HCD) component to control its view of the software I/O configuration.

In the following hardware steps, we are using an IBM 2097 processor as an example. For other processor types, you may need to consult the operator's guide that documents your processor.

### **Hardware Step 1: Add a Configuration Token to the IOCDs File**

If z/VM will be controlling the I/O configuration of the processor, you need to create a new I/O configuration data set (IOCDs) file that includes a hardware configuration token.

To create this file, take the I/O configuration program (IOCP) source file that defines your current hardware I/O configuration and run it through the IOCP utility on the CMS system disk. The IOCP utility:

- Adds a configuration token (if you specify the DYN option) to the IOCP source file
- Calls the IOCP command, which:
  - Reads, validates, and checks the syntax of the macroinstructions in the IOCP source file,
  - Generates an IOCDs file based on the input macroinstructions, and
  - Writes the newly-generated IOCDs file to the support element (SE) hard disk.

For example, if you enter:

```
iocp ZVMLPAR ( dyn
wrtal
```

you are calling the IOCP utility, which looks for the DYN or NODYN options. Because you specified DYN, the IOCP utility adds a configuration token to the file named "ZVMLPAR IOCP", calls the IOCP command, and passes the rest of the options to that command.

The IOCP command generates the IOCDs file and writes it to the SE hard disk in position A1, because you specified the WRTA1 option.

For more information on the IOCP utility and the DYN and NODYN options, see the *z/VM: CP Commands and Utilities Reference*. For more information on the IOCP command and its options, see the IOCP manual of your specific processor.

### Hardware Step 2: Shut Down the Operating Systems

After writing your hardware I/O configuration to the SE hard disk, you need to shut down all the operating systems in all the logical partitions.

### Hardware Step 3: Perform a Power-On Reset of the Processor and Enable Dynamic I/O

The last step is to place all the changes online by performing a power-on reset (POR) of the processor. At this point, select the IOCDS file you downloaded to the SE hard disk and also check the “Allow Dynamic Changes” box.

#### Note:

If you wish to prevent other logical partitions from changing the hardware I/O configuration, you can update that logical partition's security definition using the “Change LPAR Security” icon on your SE or HMC. (You can find the “Change LPAR Security” icon under the “CPC Operation Customization” task.)

After making these changes, if another logical partition tries to dynamically change the I/O configuration and that logical partition is running z/VM, CP issues error message HCP6806E with return code 0105.

## Enabling Dynamic I/O in the Software

After making the changes to the hardware to enable dynamic I/O, you need to make changes to the software (z/VM). This section describes all the changes you need to make on the software side before you can dynamically change your I/O configuration.

### Software Step 1: IPL z/VM

After performing the POR of the processor, you need to initial program load (IPL) z/VM.

### Software Step 2: Back Up Your Current System Configuration File

When z/VM is up and running, you will need to change your system configuration file. We recommend that you create a backup copy of your current system configuration file. That way, if anything goes wrong, you can easily back the changes off by using the old system configuration file.

To back up your system configuration file:

- Access the parm disk in read/write mode using the CPACCESS command
- Create the backup file by copying the current system configuration file to another file with a different file name, a different file type, or both.

**Note:** If you create the backup file on the same disk (the parm disk) as the current system configuration file, it will be much easier for you to back off any changes if a problem arises.

### Software Step 3: Update the System Configuration File

After creating the backup file, you can safely change the system configuration file. The following is a list of changes (required and optional) that you should consider making to your system configuration file:

1. Update your FEATURES statement to:
  - (Required) Turn on the dynamic I/O configuration feature:

```
Features,
:
: Enable Dynamic_I/O,
:
```

- (Optional) Allow users to execute the CP SET DEVICES command, which defines or changes the way CP handles specific real I/O devices after initialization:

```
Features,
:
: Enable Set_Devices,
:
```

- (Optional) Allow users to execute the CP SET DYNAMIC\_I/O command, which enables or disables the dynamic I/O configuration facility:

```
Features,
:
: Enable Set_Dynamic_I/O,
:
```

- (Optional) Allow CP to automatically create a real device control block (RDEV) and initialize (bring online) the associated I/O device when you add a new device:

```
Features,
:
: Enable New_Devices_Initialized_When_Added,
:
```

**Note:** The default is to initialize new devices when they are added to the I/O configuration.

**Important Note:**

Enabling the dynamic I/O configuration support is optional, so enabling these 4 operands on the FEATURES statement is optional. However, if you want to use the dynamic I/O support, you should (at a minimum) enable at least one of the following operands: DYNAMIC\_I/O or SET\_DYNAMIC\_I/O. If you decide not to enable these 2 operands, you will not be able to use the dynamic I/O support without changing your system configuration file and re-IPLing.

2. (Optional) Update your STORAGE statement to add additional storage space for subchannel measurement blocks (SCMBKs). You can allocate space for up to 65,535 more devices:

```
Storage,
:
: Scmbk nnnnn Devices_Extra,
:
```

Or, you can allocate up to 511 more pages of storage:

```
Storage,
:
: Scmbk nnn Pages_Extra,
:
```

**Note:** The SCMBK operand on the STORAGE statement will be ignored when format-1 measurement blocks are being used.

3. (Optional) Update your DEVICES statement to prevent dynamic I/O changes on specific real I/O devices:

## Migrate to Dynamic I/O

```
Devices,  
:  
NotDynamic_I/O rdev,  
NotDynamic_I/O rdev1-rdev2,  
:  
:
```

4. File the updated system configuration file on the parm disk.

### Software Step 4: Shut Down and Re-IPL z/VM

After you have made the appropriate changes to the system configuration file, you need to shut the system down so that you can bring it back up with the new system configuration file.

To shut z/VM down and bring it back up using one command, enter:

```
shutdown reipl
```

Or, you can perform a hardware IPL.

If you have successfully made the appropriate hardware and software changes for dynamic I/O, you will see the following message during the IPL:

```
HCPZPQ6857I System is enabled for dynamic I/O changes
```

---

## How to Run a System: Two Philosophies

After you have made all the appropriate hardware and software changes to enable you to dynamically change your I/O configuration and before you actually begin making dynamic I/O changes, you should understand that there is more than one method you can use to run your system using dynamic I/O. These methods (or “philosophies”) are:

- Plug 'n' Play
- Lock-Step

### The Plug 'n' Play Philosophy

The Plug 'n' Play philosophy is:

- Roll a piece of I/O equipment into the data center,
- Plug it in, and
- Use it without making any permanent changes to the processor's I/O configuration. (In other words, you issue the appropriate dynamic I/O commands to change the software I/O configuration and the hardware's (HSA) view of the I/O configuration, but you do not update the IOCP source file or generate a new IOCDs file.)

We do not recommend the Plug 'n' Play philosophy, because the changes are not permanent. If an unscheduled power-on reset occurs, you will lose all your updates.

### The Lock-Step Philosophy Recommendation

We strongly recommend that you use the Lock-Step method while making dynamic I/O changes. This method enables you to ensure that:

- All dynamic I/O changes conform to the hardware I/O configuration rules
- The I/O configuration you create is saved and automatically available for use during the next power-on reset of the processor (scheduled or unscheduled).

The Lock-Step philosophy requires you to make permanent changes to the processor's I/O configuration as you dynamically change the I/O configuration on a running system.

The Lock-Step philosophy is:

1. Plan the changes to your I/O configuration.
2. Update your IOCP source file with the planned changes.
3. Validate the IOCP source file for incompatibilities and other errors by running the updated IOCP source file through the IOCP utility on the CMS system disk.

**Note:** Specify all the options you normally specify, except the “WRTxx” option, which writes the generated IOCDS file to the support element (SE) hard disk. Instead, use the NOWRT option.

- If there are no errors, continue to the next step
  - If there are errors, update the IOCP source file and validate it again.
4. Update your software I/O configuration and the hardware's (HSA) view of the I/O configuration by issuing the appropriate CP dynamic I/O commands that correspond to the changes you made in Step 2. (For descriptions of the dynamic I/O commands, see the *z/VM: CP Commands and Utilities Reference*.)

**Note:** Using the dynamic I/O commands that are equivalent to the IOCP changes is **vital** to ensure that the new IOCDS file matches the dynamic I/O changes.

5. Write your updated I/O configuration to the support element (SE) hard disk by running the updated IOCP source file through the IOCP utility on the CMS system disk.

**Note:** Specify all the options you normally specify, including the “WRTxx” option (which writes the newly-generated IOCDS file to the SE hard disk), and also specify the DYN option (to define the hardware configuration token).

6. Make the newly-generated IOCDS file the active IOCDS file using the CP SET IOCDS\_ACTIVE command:

```
set iocds_active xx
```

where *xx* is the 2-digit string (in the range A0 through A3) you specified on the “WRTxx” option of the IOCP utility. The processor will use this active IOCDS file during the next power-on reset (POR).

See *Support Elements Operations Guide*, SC28-6802 for hardware configuration information.

Following the Lock-Step process prevents the hardware and software I/O configurations from becoming mismatched. If a mismatch were to occur and you needed to perform a power-on reset of the processor, neither the IOCP source file nor z/VM would have the changes you made using the z/VM dynamic I/O commands.



---

## Chapter 20. Planning an I/O Configuration

This chapter briefly reviews how System/390<sup>®</sup> processors (processors that support dynamic I/O configuration) communicate with their I/O devices and then goes on to show you how to build an I/O configuration. This chapter is not intended as a replacement for the IOCP manual of your specific processor.

---

### How S/390 Processors Communicate with Their I/O Devices

Before the processor can communicate with its I/O devices, it must know specific information about the hardware I/O configuration. This information is defined in a file called the I/O configuration program (IOCP) source file.

#### Building an I/O Configuration

The IOCP source file is a list of IOCP macroinstructions that define information about the:

- Channel paths on the processor
- Control units attached to the channel paths
- I/O devices assigned to the control units
- Logical partitions.

After defining the I/O configuration, you must issue the I/O configuration program (IOCP) command against your IOCP source file. The IOCP command validates and checks the syntax of the IOCP macroinstructions in the IOCP source file.

After validating and checking the syntax, the IOCP command generates an I/O configuration data set (IOCDS) file in virtual machine storage (when issued in a virtual machine) and creates a report containing information about the number and characteristics of the channel paths, control units, and subchannels (I/O devices) in the defined I/O configuration. If there were any errors in the IOCP source file, this report also contains diagnostic information about incorrectly defined IOCP macroinstructions and any processor I/O configuration rules that may have been violated.

After correcting any errors, you can use the IOCP command to write the newly-generated IOCDS file to the support element (SE) hard disk where it is stored in a "slot." Processors have 4 slots, labeled A0 through A3.

After writing the IOCDS file to the SE hard disk, you need to make that IOCDS file the active IOCDS file and perform a power-on reset (POR) of the processor. The POR tells the hardware to read the active IOCDS file (stored in one of the slots) and to bring the new I/O configuration (defined in that IOCDS file) online. Once the new I/O configuration is brought online, the processor can communicate with its I/O devices.

**Note:** You should quiesce all machine operations before performing a power-on reset, because the power-on reset operation is extremely disruptive. If you do not quiesce all machine operations before the POR, the operating system (or systems) will be abruptly terminated, resulting in a possible loss of data.

For more information about the z/VM version of IOCP or about IOCP configuration reports, see the IOCP manual of your specific processor. For more information about processor slots or performing a power-on reset, consult the operator's guide that documents your processor.

### Changing and Rebuilding the I/O Configuration

Once the I/O configuration is defined, there will come a time when you need to add a new I/O device, delete an old I/O device, or change the characteristics of an existing I/O device. Every time you physically change an I/O device, you must change the hardware and software view of the I/O configuration so the processor can communicate with that I/O device.

If you do not redefine the I/O configuration, your processor will:

- Not be able to communicate with any new I/O devices that you have physically added
- Try to communicate with any changed I/O devices as if they were the old device, which will cause errors and prevent the new devices from coming online
- Try to communicate with I/O devices that no longer physically exist in your I/O configuration.

#### Without Dynamic I/O:

If you do not have dynamic I/O enabled, every time you change the physical I/O configuration of your processor, you must:

1. Plan your changes to the I/O configuration
2. Update the IOCP source file
3. Validate the IOCP source file using the IOCP command with the NOWRT option:
  - If there are no errors, continue to the next step
  - If there are errors, update the IOCP source file and validate it again
4. Generate a new IOCDS file and write it to the SE hard disk using the IOCP command with the WRTxx option
5. Shut down the operating system
6. Make that IOCDS file the active file
7. Perform a power-on reset of the processor.

#### With Dynamic I/O:

If you have Dynamic I/O enabled, you should follow the Lock-Step process every time you change the physical I/O configuration of your processor.

### The Lock-Step Philosophy Recommendation

We strongly recommend that you use the Lock-Step method while making dynamic I/O changes. This method enables you to ensure that:

- All dynamic I/O changes conform to the hardware I/O configuration rules
- The I/O configuration you create is saved and automatically available for use during the next power-on reset of the processor (scheduled or unscheduled).

The Lock-Step philosophy requires you to make permanent changes to the processor's I/O configuration as you dynamically change the I/O configuration on a running system.

The Lock-Step philosophy is:

1. Plan the changes to your I/O configuration.
2. Update your IOCP source file with the planned changes.
3. Validate the IOCP source file for incompatibilities and other errors by running the updated IOCP source file through the IOCP utility on the CMS system disk.

**Note:** Specify all the options you normally specify, except the “WRTxx” option, which writes the generated IOCDS file to the support element (SE) hard disk. Instead, use the NOWRT option.

- If there are no errors, continue to the next step
  - If there are errors, update the IOCP source file and validate it again.
4. Update your software I/O configuration and the hardware's (HSA) view of the I/O configuration by issuing the appropriate CP dynamic I/O commands that correspond to the changes you made in Step 2. (For descriptions of the dynamic I/O commands, see the *z/VM: CP Commands and Utilities Reference*.)

**Note:** Using the dynamic I/O commands that are equivalent to the IOCP changes is **vital** to ensure that the new IOCDS file matches the dynamic I/O changes.

5. Write your updated I/O configuration to the support element (SE) hard disk by running the updated IOCP source file through the IOCP utility on the CMS system disk.

**Note:** Specify all the options you normally specify, including the “WRTxx” option (which writes the newly-generated IOCDS file to the SE hard disk), and also specify the DYN option (to define the hardware configuration token).

6. Make the newly-generated IOCDS file the active IOCDS file using the CP SET IOCDS\_ACTIVE command:

```
set iocds_active xx
```

where *xx* is the 2-digit string (in the range A0 through A3) you specified on the “WRTxx” option of the IOCP utility. The processor will use this active IOCDS file during the next power-on reset (POR).

See *Support Elements Operations Guide*, SC28-6802 for hardware configuration information.

Following the Lock-Step process prevents the hardware and software I/O configurations from becoming mismatched. If a mismatch were to occur and you needed to perform a power-on reset of the processor, neither the IOCP source file nor z/VM would have the changes you made using the z/VM dynamic I/O commands.

Note that the dynamic I/O method allows you to change the I/O configuration without the two disruptive steps: shutting down the operating systems and performing the POR. Using the dynamic I/O method, you do not need to quiesce all the machine operations. You, and your users, can continue to work uninterrupted while the channel path, control unit, and I/O device definitions change dynamically.

---

## Building an IOCP Source File

The hardware I/O configuration is defined in the I/O configuration program (IOCP) source file. The IOCP source file describes the I/O configuration using a series of IOCP macroinstructions. These macroinstructions are:

**ID** An optional macroinstruction that defines the identification information to be printed in the heading of IOCP configuration reports. You can only specify one ID macroinstruction in the IOCP source file and, if specified, it must precede all RESOURCE, CHPID, CNTLUNIT, and IODEVICE macroinstructions.

### RESOURCE

An optional macroinstruction that defines:

- Logical partition names
- MIF image ID numbers assigned to the logical partitions
- Logical channel subsystems (CSSs)
- The maximum number of devices that can be dynamically defined for a dynamic-capable IOCDS
- Reserved logical partitions for a dynamic-capable IOCDS.

The RESOURCE statement must:

- Appear only once in IOCP input file
- Follow the ID statement (if specified)
- Precede all CHPID, CNTLUNIT, and IODEVICE statements
- Include every logical partition in the configuration
- Have either the PART or PARTITION parameter specified.

### CHPID

A required macroinstruction that defines the channel paths installed on the central processor complex (CPC). You can specify as many CHPID macroinstructions in the IOCP source file as you need to define the channel paths in your I/O configuration. The keyword PCHID is required for physical channel paths to specify the physical channel ID associated with a channel path. The physical channel ID identifies the physical location (cage, slot, card port) for a channel path in the CPC. CHPID macroinstructions must follow any ID and RESOURCE macroinstructions and precede all CNTLUNIT and IODEVICE macroinstructions that refer to the specified channel paths.

### CNTLUNIT

A required macroinstruction that defines the control units attached to the channel paths installed on the CPC. You can specify as many CNTLUNIT macroinstructions in the IOCP source file as you need to define the control units in your I/O configuration. (Please note that each control unit in your I/O configuration must be defined in its own CNTLUNIT macroinstruction.) CNTLUNIT macroinstructions must follow any CHPID macroinstructions that specify channel paths used by the control unit and precede any IODEVICE macroinstructions that refer to the control unit.

### IODEVICE

A required macroinstruction that defines the I/O devices assigned to the control units attached to the channel paths installed on the CPC. You can specify up to 256 I/O devices on one IODEVICE macroinstruction and you can specify as many IODEVICE macroinstructions in the IOCP source file as you need to define the I/O devices in your I/O configuration.

IODEVICE macroinstructions must follow any CNTLUNIT macroinstructions that specify the control units used by the I/O device.

For detailed descriptions of these IOCP macroinstructions, see the IOCP manual of your specific processor.

## Understanding LPAR Mode

Before you start building an IOCP source file, you need to understand the logically partitioned (LPAR) operational mode in which your processor runs.

In LPAR mode, the processor is divided into two or more logical partitions. Each logical partition runs one operating system (such as z/VM). Some channel path types can be shared by multiple logical partitions at the same time, while others must be defined to one (and only one) logical partition.

Some channel path types can be defined as reconfigurable, allowing you to move the channel paths to another logical partition by using channel reconfiguration commands. Reconfigurable channel paths, although moved are still only defined to one logical partition at a time. To determine which channel path types can be shared by multiple logical partitions and which can be reconfigurable, consult the IOCP manual of your specific processor.

## Building an IOCP Source File

The sample IOCP source file in Chapter 24, “Sample I/O Configuration Program File,” on page 331 shows the IOCP macroinstructions you might code for a 2097 processor.

There are 36 CHPID macroinstructions that define the channel paths. The CHPID macroinstruction has multiple parameters that can be defined. The PART parameter (which can also be specified as PARTITION), tells the IOCP command to define the channel path to the specified logical partition – that is, only the specified logical partition can use this channel path. The SHARED parameter (see channel paths 18 and 2D) tells the IOCP command that the channel path can be accessed by more than one logical partition at the same time. Note that unshared channel paths can only be accessed by a single logical partition. The REC parameter, specified after the logical partition name, denotes that the specified channel path is reconfigurable – that is, it can be moved between logical partitions using channel reconfiguration commands. CHPID macroinstructions that do not specify REC are dedicated to a single logical partition and can only be moved to another logical partition at power-on reset time (using a different active IOCDS file).

After the CHPID macroinstructions, there are 28 CNTLUNIT macroinstructions that define 28 control units. (Remember, you must have one CNTLUNIT macroinstruction for each control unit in your I/O configuration.) The CNTLUNIT macroinstruction describes the characteristics of a control unit. For example, it defines the channel paths to which the control unit attaches, the type of control unit, the unit address (or addresses) to which the control unit responds, and other control unit characteristics.

After the CNTLUNIT macroinstructions, there are 32 IODEVICE macroinstructions that define 1181 I/O devices. The IODEVICE macroinstruction describes the characteristics of the I/O device. For example, it defines the device number (or address), the control unit to which the I/O device is attached, the device type, and other I/O device characteristics.

## Adding to IOCP Source Files without Using Dynamic I/O

Now that we have reviewed how to build an IOCP source file, suppose we need to add a new control unit and I/O devices to the sample IOCP source file. In the sample file, channel paths 12 and 13 are defined, but not used. We will use these two channel paths when we define a new 3990 control unit with a string of 64 3390 DASDs.

1. XEDIT the IOCP source file and define the new control unit. To do so, add the following IOCP macroinstruction somewhere after the two CHPID macroinstructions that define channel paths 12 and 13:

```
CNTLUNIT CUNUMBER=1200,PATH=(12,13),SHARED=N,UNIT=3990,          X
        UNITADD=((00,64))
```

2. Add the string of 3390 DASDs. To do so, add the following IOCP macroinstruction somewhere after the CNTLUNIT macroinstruction that you just added to define control unit X'1200':

```
DEV1200 IODEVICE ADDRESS=(1200,64),CUNUMBR=1200,UNIT=3390
```

After adding the CNTLUNIT and IODEVICE macroinstructions to the IOCP source file, leave XEDIT (making sure to file the changes).

3. Validate the newly-changed IOCP source file (which, for the purposes of this example, we are calling 2097 IOCP). To do so, use the following IOCP command:

```
iocp 2097 ( nowrt dyn
```

The DYN option tells the IOCP command to generate and add a hardware configuration token to the newly-generated IOCDS file to prepare for making dynamic I/O configuration changes.

The NOWRT option tells the IOCP command not to write the newly-generated IOCDS file to any of the slots in the support element. This allows you to check the IOCP source file for errors. The IOCP command checks for syntax errors, semantic errors, and processor-unique restrictions. The IOCP command logs these errors in the IOCP configuration report and places the report on the same disk, or SFS directory, as the IOCP source file. It has the same file name as the IOCP source file (in this case, 2097) and a file type of LISTING. If there are:

- No errors, you can continue to the next step
- Errors, you must update the IOCP source file and validate it again.

For more information about the IOCP configuration report and the return codes generated by the IOCP command, see the IOCP manual of your specific processor.

4. Generate the final IOCDS file and write the IOCDS file to the SE hard disk. To do so, use the following IOCP command:

```
iocp 2097 ( wrta1 dyn
```

The DYN option tells the IOCP command to generate and add a hardware configuration token to the newly-generated IOCDS file to prepare for making dynamic I/O configuration changes.

The WRTA1 option tells the IOCP command to write the newly-generated IOCDS file to slot A1 in the support element.

5. Check the IOCP configuration report one last time for errors and to make sure the IOCDS file was written to the SE hard disk. If there were no errors and the IOCDS file was written to the SE hard disk, you can continue to the next step. If there were errors, you will have to correct the IOCP source file and issue the IOCP command again.
6. Shut down the operating system (in this case, z/VM):

```
shutdown
```

7. Perform a power-on reset (POR) of the processor. Choose the IOCDs file that was just written to the SE (in this case A1). Also, check the “Allow Dynamic Changes” box. (For more information about performing a power-on reset, consult the operator's guide that documents your processor.)
8. IPL z/VM.

At this point, your new I/O configuration is online to both the hardware and software (z/VM). You, and your users, can begin to use the string of 64 3390 DASDs at device numbers X'1200' through X'123F'.

In Chapter 22, “Using VM Dynamic I/O Configuration,” on page 313, we will show you how to dynamically add a 3990 controller and a string of 3390 DASDs to your I/O configuration.



---

## Chapter 21. Understanding Dynamic I/O Configuration and LPARs

Using the dynamic I/O configuration facility affects your entire machine: hardware and software. This means that one logical partition can make dynamic I/O changes that affect another logical partition, or perhaps, all the logical partitions. So, the more you understand and plan for dynamic I/O changes, the less likely it will be for problems to arise.

This chapter describes:

- How to plan for dynamic I/O changes
- Dynamic I/O considerations for LPARs.

---

### Planning for Dynamic I/O Changes

If you wish to be able to dynamically change the I/O configuration of your hardware and software, there are certain decisions you need to make and certain steps you can take to greatly reduce the possibility of errors:

- Choose **one** logical partition to make all the dynamic I/O changes
- Prevent **all other** logical partitions from making dynamic I/O changes.

### Choose One Logical Partition for Dynamic I/O

You need to decide which of the logical partitions will control the hardware I/O configuration. After making the decision, you need to enable the dynamic I/O support for that logical partition and its operating system:

1. Create an IOCDS file with a hardware configuration token using the following command:

```
iocp fn ( dyn wrtxx
```

The IOCP utility adds a hardware configuration token to your IOCP source file (*fn*) and invokes the IOCP command, which generates an IOCDS file and writes the IOCDS file to the support element (SE) hard disk in slot *xx*.

2. Shut down z/VM using the following command:

```
shutdown
```

3. Make the newly-generated IOCDS file the active IOCDS file using the "Customize/Delete Activation Profiles". Also, check to make sure that the information contained on the "Reset Profile" is correct. For more information about using the IOCDS management or CONFIG screens, consult the operator's guide that documents your processor.
4. Perform a power-on reset of the processor to get the new I/O configuration online.
5. IPL z/VM:
  - Use the Load icon on the CPC Recovery frame.
6. Update your system configuration file:
  - a. Add the following to your FEATURES statement:

```
Features,  
:  
:  
    Enable Dynamic_I/O,                /* Required */  
    Enable Set_Devices,                /* Optional */  
    Enable Set_Dynamic_I/O,           /* Optional */
```

## Dynamic I/O and LPARs

```
Enable New_Devices_Initialized_When_Added, /* Optional */  
:
```

These additions turn on the dynamic I/O configuration feature, allow users to define or change the way CP handles specific real I/O devices after initialization, allow users to enable or disable the dynamic I/O configuration facility after initialization, and initialize new I/O devices as they are added to a running system, respectively.

**Note:** If you choose not to enable the CP SET DEVICES and SET DYNAMIC\_I/O commands in the system configuration file, the default is to disable these commands. This means that no one on your system will be able to issue these commands after initialization. The default of disabled is provided for installations that:

- Are concerned about security
- Do not have processors that support the dynamic I/O configuration feature.

- b. (Optional) Add one of the following to your STORAGE statement:

```
Storage,  
:  
Scmbk nnnnn Devices_Extra,  
    --- or ---  
Scmbk nnn Pages_Extra,  
:
```

This addition adds additional storage space for subchannel measurement blocks (SCMBKs).

- c. (Optional) Add as many of the following as you need to your DEVICES statement:

```
Devices,  
:  
NotDynamic_I/O rdev,  
NotDynamic_I/O rdev1-rdev2,  
:
```

This addition prevents dynamic I/O changes on specific real I/O devices.

7. Re-IPL z/VM to bring the new system configuration file online:

- Use the Load icon on the CPC Recovery frame.

During initialization, you will see the following message:

```
HCP6857I System is enabled for dynamic I/O changes
```

Which tells you that z/VM can dynamically change your I/O configuration after initialization completes.

The other logical partitions, and their operating systems, will reap the benefits of the dynamic I/O changes, but will not make any dynamic I/O changes of their own.

For example, suppose your processor has two logical partitions: one running z/VM and one running z/OS. You decide to let z/VM make the dynamic I/O changes. After updating the LPSEC screen, generating an IOCDS file with a configuration token, and changing the system configuration file, the z/VM logical partition can add, delete, or change the I/O configuration of the processor. The z/OS logical partitions will make software-only changes using the Hardware Configuration Definition (HCD) component.

## The Lock-Step Philosophy Recommendation

We strongly recommend that you use the Lock-Step method while making dynamic I/O changes. This method enables you to ensure that:

- All dynamic I/O changes conform to the hardware I/O configuration rules
- The I/O configuration you create is saved and automatically available for use during the next power-on reset of the processor (scheduled or unscheduled).

The Lock-Step philosophy requires you to make permanent changes to the processor's I/O configuration as you dynamically change the I/O configuration on a running system.

The Lock-Step philosophy is:

1. Plan the changes to your I/O configuration.
2. Update your IOCP source file with the planned changes.
3. Validate the IOCP source file for incompatibilities and other errors by running the updated IOCP source file through the IOCP utility on the CMS system disk.

**Note:** Specify all the options you normally specify, except the “WRTxx” option, which writes the generated IOCDS file to the support element (SE) hard disk. Instead, use the NOWRT option.

- If there are no errors, continue to the next step
  - If there are errors, update the IOCP source file and validate it again.
4. Update your software I/O configuration and the hardware's (HSA) view of the I/O configuration by issuing the appropriate CP dynamic I/O commands that correspond to the changes you made in Step 2. (For descriptions of the dynamic I/O commands, see the *z/VM: CP Commands and Utilities Reference*.)

**Note:** Using the dynamic I/O commands that are equivalent to the IOCP changes is **vital** to ensure that the new IOCDS file matches the dynamic I/O changes.

5. Write your updated I/O configuration to the support element (SE) hard disk by running the updated IOCP source file through the IOCP utility on the CMS system disk.

**Note:** Specify all the options you normally specify, including the “WRTxx” option (which writes the newly-generated IOCDS file to the SE hard disk), and also specify the DYN option (to define the hardware configuration token).

6. Make the newly-generated IOCDS file the active IOCDS file using the CP SET IOCDS\_ACTIVE command:

```
set iocds_active xx
```

where *xx* is the 2-digit string (in the range A0 through A3) you specified on the “WRTxx” option of the IOCP utility. The processor will use this active IOCDS file during the next power-on reset (POR).

See *Support Elements Operations Guide*, SC28-6802 for hardware configuration information.

Following the Lock-Step process prevents the hardware and software I/O configurations from becoming mismatched. If a mismatch were to occur and you

needed to perform a power-on reset of the processor, neither the IOCP source file nor z/VM would have the changes you made using the z/VM dynamic I/O commands.

### Prevent All Other Logical Partitions from Using Dynamic I/O

After enabling the logical partition that you want to control the dynamic I/O changes, you should disable dynamic I/O in all the other logical partitions.

#### To disable dynamic I/O support in the other logical partitions —

On “Customization/Delete Activation Profiles” under your partition images profiles, only the controlling LPAR has “Input/Output Configuration Control” selected.

#### To disable dynamic I/O support in z/VM —

Do nothing. By default, the dynamic I/O configuration support is disabled in the system configuration file. If you want to be very sure that the dynamic I/O support is disabled, add the following to the FEATURES statement in your system configuration file:

```
Disable Dynamic_I/O
```

#### To disable dynamic I/O support in other operating systems —

Consult the manuals that describe the other operating systems.

---

## Dynamic I/O Considerations for LPARs

Before you use the dynamic I/O commands, you should understand how the dynamic I/O configuration support works. When Logical Partition A dynamically adds, deletes, or changes an I/O device defined to Logical Partition B, Logical Partition B gets an I/O machine check (IPI or IPM) telling it that the device was added, deleted, or changed.

At this point, the status of the device depends upon what dynamic I/O commands you issued in Logical Partition A, how Logical Partition B is set up to handle new, changed, and deleted devices, and how well you planned the dynamic I/O changes. The device status can be:

- Online and operational
- Offline
- “Boxed”
- Deleted.

These possibilities run the full spectrum of device status. With these kinds of extremes, you must do adequate planning to make sure your dynamic I/O changes happen smoothly.

As you can see, the dynamic I/O configuration support has system-wide implications when defining, deleting, and changing channel paths, control units, and I/O devices. In most cases, adding a new channel path, control unit, or I/O device to a logical partition will not cause a problem. However, changing or deleting channel paths, control units, or I/O devices in logical partitions can be disastrous. For example, suppose one logical partition makes a dynamic I/O change or deletion that affects another logical partition. If I/O operations are in progress on that second logical partition when you issue the dynamic I/O command, those I/O operations may not complete before the dynamic I/O command does, resulting in lost or corrupted data. Thus, you need to manually coordinate changes and deletions across all logical partitions. If the other logical partition is running z/VM, this means that the other logical partition should vary

the device and its associated subchannel offline before you dynamically change or delete the device or its associated channel path or control unit.

Also, when you define new reconfigurable channel paths to logical partitions, only one logical partition can have access to that channel path at a time. For shared channel paths on EMIF-capable processors, you must define the logical partitions that can access the shared channel path (called a candidate list in IOCP) and the initial access list for logical partitions. All of the rules that apply to the IOCP apply to the dynamic I/O configuration support.



---

## Chapter 22. Using VM Dynamic I/O Configuration

This chapter shows you how to dynamically change your I/O configuration. It explains the process we recommend that you use, discusses the concept of configuration mode, and then takes you through a few examples of dynamically changing your I/O configuration using z/VM.

---

### The Dynamic I/O Process

This topic describes the dynamic I/O process.

#### The Lock-Step Philosophy Recommendation

We strongly recommend that you use the Lock-Step method while making dynamic I/O changes. This method enables you to ensure that:

- All dynamic I/O changes conform to the hardware I/O configuration rules
- The I/O configuration you create is saved and automatically available for use during the next power-on reset of the processor (scheduled or unscheduled).

The Lock-Step philosophy requires you to make permanent changes to the processor's I/O configuration as you dynamically change the I/O configuration on a running system.

The Lock-Step philosophy is:

1. Plan the changes to your I/O configuration.
2. Update your IOCP source file with the planned changes.
3. Validate the IOCP source file for incompatibilities and other errors by running the updated IOCP source file through the IOCP utility on the CMS system disk.

**Note:** Specify all the options you normally specify, except the “WRTxx” option, which writes the generated IOCDS file to the support element (SE) hard disk. Instead, use the NOWRT option.

- If there are no errors, continue to the next step
  - If there are errors, update the IOCP source file and validate it again.
4. Update your software I/O configuration and the hardware's (HSA) view of the I/O configuration by issuing the appropriate CP dynamic I/O commands that correspond to the changes you made in Step 2. (For descriptions of the dynamic I/O commands, see the *z/VM: CP Commands and Utilities Reference*.)

**Note:** Using the dynamic I/O commands that are equivalent to the IOCP changes is **vital** to ensure that the new IOCDS file matches the dynamic I/O changes.

5. Write your updated I/O configuration to the support element (SE) hard disk by running the updated IOCP source file through the IOCP utility on the CMS system disk.

**Note:** Specify all the options you normally specify, including the “WRTxx” option (which writes the newly-generated IOCDS file to the SE hard disk), and also specify the DYN option (to define the hardware configuration token).

## Using Dynamic I/O

6. Make the newly-generated IOCDS file the active IOCDS file using the CP SET IOCDS\_ACTIVE command:

```
set iocds_active xx
```

where *xx* is the 2-digit string (in the range A0 through A3) you specified on the “WRT*xx*” option of the IOCP utility. The processor will use this active IOCDS file during the next power-on reset (POR).

See *Support Elements Operations Guide*, SC28-6802 for hardware configuration information.

Following the Lock-Step process prevents the hardware and software I/O configurations from becoming mismatched. If a mismatch were to occur and you needed to perform a power-on reset of the processor, neither the IOCP source file nor z/VM would have the changes you made using the z/VM dynamic I/O commands.

If you use the Lock-Step process, you will:

- Know, at any time, what your I/O configuration looks like
- Ensure that your I/O configuration is valid
- Ensure that the I/O configuration defined in the hardware system area (HSA) always matches the I/O configuration stored on the support element (SE) hard disk
- Ensure that a power-on reset (POR) of the processor will yield the same I/O configuration after the POR as you had before the POR.

There is another process called Plug 'n' Play. In this process, you issue the dynamic I/O commands, but do not update the I/O configuration stored on the processor. While both processes work in some environments, we strongly recommend that you use the Lock-Step process. If there is an unscheduled power-on reset of the processor, using the Lock-Step process keeps your dynamic I/O changes safe, while using the Plug 'n' Play process causes the processor to use an IOCDS file that does not contain any of your dynamic I/O changes. If it is important to have these dynamic I/O changes on your system, The Plug 'n' Play process forces you to repeat the task of changing your I/O configuration dynamically after the power-on reset completes.

For example, suppose you use the Plug 'n' Play process to make some dynamic I/O changes. Time passes. Some event occurs which causes you to perform a power-on reset of your processor. Your dynamic I/O changes are gone. If you really need those changes, you will have to either remember what you did or keep good records because you have to make the same changes over again.

If you had used the Lock-Step process, your dynamic I/O changes would have been in the active IOCDS file that the processor used during the power-on reset. You would not have to remember what you did or keep a record because your changes are safe in the active IOCDS file.

---

## Understanding Configuration Mode

Before you begin to dynamically change your I/O configuration, you should understand what happens to CP when you issue a dynamic I/O command. When you issue a single dynamic I/O command, CP puts you in a state called configuration mode (or “config mode”), processes the dynamic I/O command, and

then takes you out of configuration mode. Configuration mode is a machine state that is used to change your I/O configuration dynamically.

## Controlling Configuration Mode

If you are planning to issue several dynamic I/O commands to change your I/O configuration, you should consider the performance benefits of controlling configuration mode yourself. For example, suppose you issue five dynamic I/O commands individually. This causes CP to enter configuration mode five times and exit configuration mode five times. CP may spend more time entering and exiting configuration mode than it does processing your dynamic I/O commands.

Instead of waiting for CP to turn configuration mode on, you can do it yourself using the SET CONFIGMODE command:

```
set configmode on
```

Then, issue your five dynamic I/O commands. When they complete, you can turn configuration mode off using the SET CONFIGMODE command again:

```
set configmode off
```

When you control configuration mode, CP only has to enter configuration mode once and exit configuration mode once, instead of entering five times and exiting five times.

## Checking Configuration Mode Status

From the following sections, you know that CP can control configuration mode (when a user issues a single dynamic I/O command) and users with the appropriate privilege class can control configuration mode (when they issue the SET CONFIGMODE command). If you have more than one person authorized to make dynamic I/O changes, there may come a time when a user tries to enter configuration mode, but is denied because another user has already put the processor in configuration mode.

When this happens, CP issues the following error message:

```
HCP6819E A dynamic I/O command is currently executing for user userid
```

To prevent this, you might want to use the QUERY CONFIGMODE command to check whether someone has turned configuration mode on before you try to issue any dynamic I/O commands:

- If no one is dynamically changing the I/O configuration, you will see the following message:

```
query configmode
System is not in configuration mode
Ready;
```

- If someone has issued a single dynamic I/O command or has issued the SET CONFIGMODE ON command, you will see the following message:

```
query configmode
System is in configuration mode for user MYRIAM
Ready;
```

Now that you understand the recommended process for dynamically changing your I/O configuration and you understand how configuration mode works, you can begin to dynamically change your I/O configuration. The following sections show you how to do this.

Please note that the examples in the following sections make the following assumptions:

- The following examples are written as if you were using the IOCP source file in Chapter 24, “Sample I/O Configuration Program File,” on page 331.
- The following examples assume that only one logical partition is making dynamic I/O changes and z/VM is the operating system running in that logical partition.

### When Configuration Mode Is Interrupted

In the previous sections, we discussed what configuration mode is and how you get into and out of it. These discussions described the normal ways to enter and exit configuration mode.

However, there may be occasions when you are in configuration mode and a problem occurs before you can leave configuration mode. For example:

- CP abends
- Your processor loses power
- Someone issues a CP SHUTDOWN REIPL command
- Someone issues a System Reset Clear from the hardware console and performs a hardware IPL
- Someone issues a Load Clear from the hardware console
- The user that caused you to enter configuration mode logs off or is forced off.

In each of these interruptions, either CP or the hardware will take you out of configuration mode. However, because you were in the middle of making one or more dynamic I/O changes, we cannot predict the state in which these changes were left.

The only interruption that causes a known state is when the processor loses power. To recover from this interruption, you must power the processor on, which involves a power-on reset (POR). During the POR, your I/O configuration is defined by the last IOCDS file that you selected as the active file. Thus, the state of your I/O configuration after the processor loses power is a known state defined by the active IOCDS file.

For all other interruptions, your I/O configuration is marked as not being valid using the “Invalid Configuration Bit” (a flag in the hardware). Every time you (or CP) enter configuration mode, the Invalid Configuration Bit is turned on. Every time you (or CP) exit configuration mode (without being interrupted), the Invalid Configuration Bit is turned off.

For the following interruptions:

- CP abended
- Someone issued a CP SHUTDOWN REIPL command
- Someone issues a System Reset Clear from the hardware console and performs a hardware IPL
- Someone issues a Load Clear from the hardware console

CP issues a message to tell the system operator that the “Invalid Configuration Bit” was turned on in the hardware:

```

HCPI6831I
HCPI6831I The Invalid Configuration bit is on in the hardware.
HCPI6831I If you do not want to reset the I/O configuration,
HCPI6831I enter SHUTDOWN. Otherwise, enter one of the
HCPI6831I following options:
HCPI6831I

```

The system operator can choose to shut z/VM down or to continue IPLing z/VM using the standard startup prompts. If the system operator shuts z/VM down, the system is left in a wait state and the Invalid Configuration Bit is left on. If the system operator continues with the IPL, the Invalid Configuration Bit is turned off and the IPL continues normally.

For the following interruption:

- The user that caused you to enter configuration mode logs off or is forced off

the Invalid Configuration Bit is left on. The next time a user enters a dynamic I/O command or queries z/VM's dynamic I/O capability, CP issues the following response:

```
Dynamic I/O changes are allowed, but the I/O configuration is not currently valid
```

To correct this problem, you need to reset the Invalid Configuration Bit. To do so, issue the following commands:

```

set configmode on reset
Ready;

set configmode off
Ready;

```

The RESET operand of the first SET CONFIGMODE command allows you to enter configuration mode even if the Invalid Configuration Bit is on. The second SET CONFIGMODE command takes you out of configuration mode and turns the Invalid Configuration Bit off.

---

## Example 1: Adding a String of 3390 DASDs and a 3990 Controller

This example shows you how to add 64 3390 disk drives and a 3990 controller to two existing channel paths (unused CHPIDs 12 and 13), using the sample IOCP source file in Chapter 24, "Sample I/O Configuration Program File," on page 331.

In this example, we will change the I/O configuration by adding a 3990 controller with two channel paths: unused CHPIDs 12 and 13. (Please note that these two channel paths are already defined and online.) Then, we will add 64 3390 DASDs to the 3990 controller that we just added.

To add these DASDs and this controller, we will be using the Lock-Step process:

1. Update the IOCP source file (2097 IOCP A):

- a. Enter:

```
xedit 2097 iocp
```

- b. Add the following CNTLUNIT macroinstruction between the control unit definitions for control units 11C0 and 1400:

```

CNTLUNIT CUNUMBER=1200,PATH=(12,13),
UNITADD=((00,64)),SHARED=N,UNIT=3990

```

- c. Add the following IODEVICE macroinstruction between the I/O device definitions for device numbers 11C0 and 1400:

```
IODEVICE UNIT=3390,ADDRESS=(1200,64),CUNUMBR=(1200)
```

- d. File the changes back onto your A-disk or SFS directory.
2. Verify the newly-changed IOCP source file (2097 IOCP A) using the IOCP utility:

```
iocp 2097 ( dyn nowrt
```

We specified the DYN option because we want the IOCP utility to add a hardware configuration token to the newly-generated IOCDS file. We specified the NOWRT option because we do not want to write the newly-generated IOCDS file to the SE hard disk until we verify that there are no syntax, semantic, or processor-specific errors in the IOCP source file. You can find all the errors in the IOCP configuration report (2097 LISTING A).

If there are no errors from the IOCP utility, you can continue to the next step. If there are errors from the IOCP utility, you must update the IOCP source file and validate it again.

For more information about the IOCP configuration report and the return codes generated by the IOCP command, see the IOCP manual of your specific processor.

3. Use the dynamic I/O commands to change the software's (z/VM's) and the hardware's (HSA's) view of the I/O configuration. You can find complete descriptions of all the dynamic I/O commands listed in this example in the *z/VM: CP Commands and Utilities Reference*.

As stated previously, we already have two existing channel paths (12 and 13) that are defined and online. So, we only need to create the control unit and I/O device definitions.

- a. Turn configuration mode on using the following command:

```
set configmode on
```

- b. Define a control unit with one channel path using the following command:

```
define cu 1200 type * unshared unit_address 00-3f chpid 12
```

- c. Define 64 I/O devices (subchannels) using the following command:

```
define device 1200-123f unit_address 00 cu_number 1200 partition vml
```

- d. Turn configuration mode off using the following command:

```
set configmode off
```

At this point, channel path 12 is online because it was defined in the IOCP source file that became the active IOCDS file used at POR time and we made no changes to it. If your z/VM system is set up to initialize new devices as they are added to a running system, CP initializes the devices and brings them online. To tell CP to initialize new devices as they are added to a running system, use the CP SET NEW\_DEVICES INITIALIZE\_WHEN\_ADDED ON command or add a FEATURES ENABLE NEW\_DEVICES\_INITIALIZED\_WHEN\_ADDED statement to your system configuration file.

If channel path 12 had been offline (defined using the CP DEFINE CHPID or PATH command), you would have had to vary on channel path 12 before the devices could be initialized. To do so, use the following command:

```
vary online chpid 12
```

At this point, if your z/VM system was set up to initialize new devices as they were added to a running system, CP would have initialized the devices and brought them online.

If your z/VM system was not set up to initialize new devices as they were added to a running system, you would have had to vary on the new devices manually using the following command:

```
vary online 1200-123f
```

- e. At this point, you have defined a control unit with 64 devices, all of which run through channel path 12. But, we said previously that the devices would run through channel paths 12 and 13. We forgot to specify channel path 13 on the DEFINE CU command.

Actually, we did not forget. We did this on purpose to show you how easy it is to correct a mistake like this using a CP MODIFY command. At this point, channel path 13 is already online (defined in the IOCP source file and the IOCDS file that you generated from it). So, you only need to use the dynamic I/O support to add channel path 13 to control unit 1200.

To change the control unit definition by adding the second channel path, use the following command:

```
modify cu 1200 add chpid 13
```

Again, channel path 13 is online (defined in the IOCP source file that became the active IOCDS file used at POR time), so both channel paths and the 64 new devices are online.

- 4. Generate the final version of the IOCDS file and write it to the SE hard disk:

```
iocp 2097 ( dyn wrta1
```

We specified the WRTA1 option to write the IOCDS file to slot A1 on the SE hard disk.

- 5. Make the newly-generated IOCDS file the active IOCDS file using the following command:

```
set iocds_active a1
```

After completing these steps, you will have dynamically changed the I/O configuration of the software (z/VM) and the hardware (in the HSA). Also, you will have created a new active IOCDS file that matches the dynamic I/O changes, thereby ensuring that these changes will survive a power-on reset (POR) of the processor.

---

## Example 2: Adding a String of Shared 3490 Tape Drives to Two Logical Partitions

This example shows you how to take an existing unshared channel path, change it to a channel path shared between two logical partitions, add an ESCON control unit, and add a string of 3490 tape drives, using the sample IOCP source file in Chapter 24, “Sample I/O Configuration Program File,” on page 331.

In this example, we will delete channel path 2C, define it again as a channel path shared between two logical partitions, add an ESCON control unit, and add a string of 3490 tape drives. As in Example 1, we will be using the Lock-Step process. Thus, the process remains the same, only the dynamic I/O commands will change.

To change the channel path, add the control unit, and add the tape drives:

- 1. Update the IOCP source file (2097 IOCP A):

- a. Enter:

```
xedit 2097 iocp
```

- b. Change the existing channel path definition (CHPID macroinstruction) for channel path 2C to:

```
CHPID PATH=(2C),TYPE=CNC,SHARED
```

- c. Add the following CNTLUNIT macroinstruction between the control unit definitions for control units 1B00 and 2D00:

## Using Dynamic I/O

```
CNTLUNIT CUNUMBR=2C00,PATH=(2C),UNIT=3490,UNITADD=((00,16))
```

- d. Add the following IODEVICE macroinstruction between the I/O device definitions for devices 1B00 and 2D00:

```
IODEVICE ADDRESS=(2C00,16),CUNUMBR=2C00,UNIT=3490
```

- e. File the changes back onto your A-disk or SFS directory.

2. Verify the newly-changed IOCP source file (2097 IOCP A) using the IOCP utility:

```
iocp 2097 ( dyn nowrt
```

We specified the DYN option because we want the IOCP utility to add a hardware configuration token to the newly-generated IOCDS file. We specified the NOWRT option because we do not want to write the newly-generated IOCDS file to the SE hard disk until we verify that there are no syntax, semantic, or processor-specific errors in the IOCP source file. You can find all the errors in the IOCP configuration report (2097 LISTING A).

If there are no errors from the IOCP utility, you can continue to the next step. If there are errors from the IOCP utility, you must update the IOCP source file and validate it again.

For more information about the IOCP configuration report and the return codes generated by the IOCP command, see the IOCP manual of your specific processor.

3. Use the dynamic I/O commands to change the software's (z/VM's) and the hardware's (HSA's) view of the I/O configuration. You can find complete descriptions of all the dynamic I/O commands listed in this example in the *z/VM: CP Commands and Utilities Reference*.

As stated previously, channel path 2C is an existing channel path. So, we need to delete channel path 2C, define it again as a channel path shared between two logical partitions, add an ESCON control unit, and add a string of 3490 tape drives.

- a. Turn configuration mode on using the following command:

```
set configmode on
```

- b. Delete existing control unit 2C using the following command:

```
delete chpid 2c
```

- c. Define channel path 2C again as a channel path shared between logical partitions CAMBVM3 and CAMBVM4 with both logical partitions having initial access using the following command:

```
def chpid 2c pchid 120 type escon shared acc cambvm3 cambvm4 init cambvm3 cambvm4
```

**Note:** In this example, logical partitions CAMBVM3 and CAMBVM4 are both running z/VM.

- d. Add the ESCON control unit and attach it to channel path 2C using the following command:

```
define cu 2c00 type escon unit_address 00-0f chpid 2c
```

- e. Add the string of tape drives and assign them to control unit 2C00 using the following command:

```
def device 2c00-2c0f unit_address 00 cu 2c00 partition cambvm3 cambvm4
```

- f. Turn configuration mode off using the following command:

```
set configmode off
```

At this point, you have defined the changed channel path, new control unit, and new I/O devices. Now, you must vary the channel path on in both logical partitions: CAMBVM3 and CAMBVM4.

- g. You can vary the channel path on using the following command in **each logical partition**:

```
vary online chpid 2c
```

At this point, if your z/VM system is set up to initialize new devices as they are added to a running system, CP initializes the devices and brings them online. To tell CP to initialize new devices as they are added to a running system, use the CP SET NEW\_DEVICES INITIALIZE\_WHEN\_ADDED ON command or add a FEATURES ENABLE NEW\_DEVICES\_INITIALIZED\_WHEN\_ADDED statement to your system configuration file.

If your z/VM system does not initialize new devices as they are added to a running system, you must vary on the new devices using the following command:

```
vary online 2c00-2c0f
```

At this point, you have a shared channel path, an ESCON control unit, and 16 3490 tape drives, all of which are online.

4. Generate the final version of the IOCDS file and write it to the SE hard disk:

```
iocp 2097 ( dyn wrta2
```

We specified the WRTA2 option to write the IOCDS file to slot A2 on the SE hard disk.

5. Make the newly-generated IOCDS file the active IOCDS file using the following command:

```
set iocds_active a2
```

After completing these steps, you will have dynamically changed the I/O configuration of the software (z/VM) and the hardware (in the HSA). Also, you will have created a new active IOCDS file that matches the dynamic I/O changes, thereby ensuring that these changes will survive a power-on reset (POR) of the processor.

**Note:** In this example, z/VM was the operating system in both logical partitions. If you have z/VM making dynamic I/O changes that affect another logical partition and that logical partition is not running z/VM, then please consult the documentation for the other operating system for instructions on how to bring a channel path and the devices online.

---

### Example 3: Replacing a String of 3380 DASDs with RAMAC DASD

This example shows you how to delete a string of 3380 DASD and replace them with a string of RAMAC DASD, using the sample IOCP source file in Chapter 24, "Sample I/O Configuration Program File," on page 331.

In this example, we will delete 32 device definitions and 1 control unit definition for the 3380 DASDs. Then, we will define a new control unit and 64 RAMAC DASD device definitions. As in the previous examples, we will be using the Lock-Step process. Thus, the process remains the same, only the dynamic I/O commands will change.

To replace the 3380 DASDs with RAMAC DASDs:

1. Update the IOCP source file (2097 IOCP A):

- a. Enter:

```
xedit 2097 iocp
```

- b. For control unit 3100, change the CNTLUNIT macroinstruction for the 32 3380 DASDs so that it has room for 64 DASDs. That is, on the second line, change the "32" in the UNITADD parameter to "64". The macroinstruction looks like this when you are done:

```
CNTLUNIT CUNUMBR=3100,PATH=(19,1B),LINK=(EE,EF), X
        UNITADD=((00,64)),UNIT=3990
```

- c. For device 3100, change the IODEVICE macroinstruction that defines the 32 3380 DASDs to define 64 RAMAC DASDs. That is, on the first line, change the "32" in the ADDRESS parameter to "64", and change the "3380" in the UNIT parameter to "9391". The macroinstruction looks like this when you are done:

```
IODEVICE ADDRESS=(3100,64),CUNUMBR=(3100),UNIT=9391,UNITADD=00
```

- d. File the changes back onto your A-disk or SFS directory.

2. Verify the newly-changed IOCP source file (2097 IOCP A) using the IOCP utility:

```
iocp 2097 ( dyn nowrt
```

We specified the DYN option because we want the IOCP utility to add a hardware configuration token to the newly-generated IOCDS file. We specified the NOWRT option because we do not want to write the newly-generated IOCDS file to the SE hard disk until we verify that there are no syntax, semantic, or processor-specific errors in the IOCP source file. You can find all the errors in the IOCP configuration report (2097 LISTING A).

If there are no errors from the IOCP utility, you can continue to the next step. If there are errors from the IOCP utility, you must update the IOCP source file and validate it again.

For more information about the IOCP configuration report and the return codes generated by the IOCP command, see the IOCP manual of your specific processor.

3. Use the dynamic I/O commands to change the software's (z/VM's) and the hardware's (HSA's) view of the I/O configuration. You can find complete descriptions of all the dynamic I/O commands listed in this example in the *z/VM: CP Commands and Utilities Reference*.

As stated previously, we are replacing 32 3380 DASDs with 64 RAMAC DASDs. So, we need to delete the 32 DASDs and their control unit and define them again for 64 DASDs.

**Note:** Before we can delete the 32 3380 DASDs, they must be offline and subchannel disabled (subchannel offline).

- a. Take the 32 DASDs offline using the following command:  

```
vary offline 3100-311f
```
- b. Disable the subchannels of the 32 DASDs using the following command:  

```
vary offline subchannel 3100-311f
```
- c. Turn configuration mode on using the following command:  

```
set configmode on
```
- d. Delete the existing 32 3380 DASDs using the following command:  

```
delete device 3100-311f unit_address 00 cu_number 3100
```
- e. Delete existing control unit 3100 using the following command:  

```
delete cu 3100
```

At this point, you have deleted the 32 devices and control unit. Now, we can define the new control unit and the 64 devices.

- f. Add the control unit using the following command:  

```
define cu 3100 type escon unit_addr 00-3f link_addr ee ef chpid 19 1b
```
- g. Add the 64 RAMAC DASD using the following command:  

```
define device 3100-313f unit_address 00 cu_number 3100 partition vml
```
- h. Turn configuration mode off using the following command:  

```
set configmode off
```

At this point, you have replaced the 32 3380 DASDs with 64 RAMAC DASDs. If channel paths 19 and 1B are online and your z/VM system is set up to initialize new devices as they are added to a running system, CP initializes the 64 new device addresses (X'3100' to X'313F') and brings them online.

If channel paths 19 and 1B are online but your z/VM system is not set up to initialize new devices as they are added to a running system, you must vary on all 64 of the devices using the following command:

```
vary online 3100-313f
```

If channel paths 19 and 1B are offline, you must vary them on before the devices can be initialized. To do so, use these commands:

```
vary online chpid 19
Ready;
```

```
vary online chpid 1b
Ready;
```

Then, vary on the devices, as necessary.

**Note:** To tell CP to initialize new devices as they are added to a running system, use the CP SET NEW\_DEVICES INITIALIZE\_WHEN\_ADDED ON command or add a FEATURES ENABLE NEW\_DEVICES\_INITIALIZED\_WHEN\_ADDED statement to your system configuration file.

4. Generate the final version of the IOCDS file and write it to the SE hard disk:  

```
iocp 2097 ( dyn wrta3
```

We specified the WRTA3 option to write the IOCDS file to slot A3 on the SE hard disk.
5. Make the newly-generated IOCDS file the active IOCDS file using the following command:  

```
set iocds_active a3
```

After completing these steps, you will have dynamically changed the I/O configuration of the software (z/VM) and the hardware (in the HSA). Also, you will have created a new active IOCDS file that matches the dynamic I/O changes, thereby ensuring that these changes will survive a power-on reset (POR) of the processor.

---

## Example 4: An Alternate Way

As you become more familiar with the dynamic I/O commands, you will realize that there are occasions when there is more than one way of accomplishing your task. In Example 3 you used the dynamic I/O commands to delete the 32 3380 DASDs, delete the control unit, define the control unit again, and define the 64 RAMAC DASDs. This is one way to replace 32 3380 DASDs with 64 RAMAC DASDs.

## Using Dynamic I/O

Another way is to change the control unit to recognize an additional 32 devices (unit addresses) and add 32 more devices. In this scenario, the dynamic I/O commands (Step 3 of the previous Example 3) would be:

- a. Take the 32 DASDs offline using the following command:

```
vary offline 3100-311f
```

At this point, you can physically remove the 3380 DASDs and hook up the RAMAC DASDs.

- b. Change the total number of unit addresses from 32 to 64 by adding 32 additional unit addresses after unit address X'1F' using the following command:

```
modify cu 3100 add unit_address 20-3F
```

- c. Add 32 more DASDs using the following command:

```
define device 3120-313f unit_address 20 cu_number 3100 partition vm1
```

At this point, you have replaced the 32 3380 DASDs with 64 RAMAC DASDs. If channel paths 19 and 1B are online and your z/VM system is set up to initialize new devices as they are added to a running system, CP initializes the 32 new device addresses (X'3120' to X'313F') and brings them online. Because the first 32 device addresses (X'3100' to X'311F') existed before, they are not considered to be new. You must vary them online manually.

- d. Bring the original 32 DASDs online using the following command:

```
vary online 3100-311f
```

At this point, the devices are initialized and you have replaced your 32 3380 DASDs with 64 RAMAC DASDs.

By now, you should have a good understanding about how the IOCP and dynamic I/O configuration support works. You also should have a good understanding of the Lock-Step process of dynamically changing your I/O configuration.

---

## Chapter 23. Understanding Potential Problem Areas

This chapter lists and describes some potential problems that might arise and what you can do to avoid them. Some of the topics that are discussed in this chapter were already discussed in previous chapters or in other documents. We chose to repeat them here because they are important topics that can cause serious problems if overlooked.

The Lock-Step method ensures that the active IOCDs file, the hardware system area (HSA), and z/VM are all using the same I/O configuration.

---

### z/VM and z/OS Do Not Mix

If you have z/VM running in one logical partition and z/OS running in another logical partition, then both operating systems have the ability to dynamically change the hardware and software view of the I/O configuration. **They cannot both make dynamic I/O changes.**

If one operating system discovers (by checking the configuration token) that the other operating system “owns” the I/O configuration, the operating system that discovered the change will disable its own dynamic I/O support. That is, if z/OS finds a VM configuration token in the hardware system area (HSA), z/OS disables its dynamic I/O support and, thereafter, can only make changes to the software I/O configuration. If z/VM finds a z/OS configuration token, z/VM disables its dynamic I/O support and, thereafter, can make software-only changes.

*How to Circumvent This Problem:* Decide who will make the changes, z/VM or z/OS. Then disable the dynamic I/O support in any operating systems that will not be making dynamic I/O changes, thus preventing an accidental overlap of control.

In z/VM, you can disable the dynamic I/O support:

- In the system configuration file using the following operands of the FEATURES statement:
  1. DISABLE DYNAMIC\_I/O — turns the dynamic I/O support off
  2. DISABLE SET\_DYNAMIC\_I/O — prevents anyone from turning the dynamic I/O support back on after initialization
- Using the CP SET DYNAMIC\_I/O OFF command.

You can also disable the support for one logical partition using the LPSEC (Logical Partition SECurity) screen of your processor. Specify “N” for the IOC option of the logical partition that you want to prevent from making dynamic I/O changes. (Note that you can change the LPSEC screen at any time, because it does not require a power-on reset of the processor for the changes to go into effect.) After specifying “N”, the specified logical partition will no longer be capable of changing the I/O configuration of the processor, thereby preventing that logical partition from changing the I/O configuration of another logical partition.

### But a Little Mixing Can Help to Manage z/VM and z/OS Guests

The SET TOKEN command is provided to allow the system programmer to set the description fields (DESC1 and DESC2) within the hardware I/O-configuration

## Potential Problems

token. It can be useful to set these fields when you are running OS/390® or z/OS guests on VM. OS/390 and z/OS use the DESC1 field as the high-level dataset-name qualifier of the OS/390 or z/OS I/O-definition fields (IODF). They use the DESC2 field to select which of several IODFs are to be used, with the DESC2 field taking on values in the form "IODF $nm$ ", where  $nm$  can have a value from 00 to 99.

By setting the DESC1 and DESC2 fields to the proper values for an OS/390 or z/OS IODF that is to be used by one or more OS/390 or z/OS guests, these guest operating systems will automatically select that IODF for their I/O configuration when the guests are IPLed.

VM itself makes no use of the DESC1 and DESC2 fields.

---

## Monopoly Is the Name of the Game

We strongly recommend that you give the power of dynamically changing the I/O configuration to only one logical partition. In other words, give one logical partition a “dynamic I/O monopoly”.

Allowing multiple logical partitions to dynamically change the I/O configuration (even if the logical partitions are all running z/VM) can render your I/O configuration **unusable**. When this happens, you have no choice but to perform a power-on reset to get back to a known, valid I/O configuration.

***How to Circumvent This Problem:*** Decide which logical partition will make the dynamic I/O changes. Then disable the dynamic I/O support in any logical partitions that will not be making dynamic I/O changes, thus preventing an accidental overlap of control. To disable the dynamic I/O support in a logical partition, use the LPSEC screen (Logical Partition SECURITY). On the LPSEC screen, there is an IOC option. Change the IOC option to “N” for all logical partitions except the logical partition that will be dynamically changing the hardware I/O configuration.

**Note:** You can change the LPSEC screen at any time, because it does not require a power-on reset of the processor for the changes to go into effect.

---

## Play It Safe

The dynamic I/O commands are like any other z/VM commands: temporary. They only remain in effect until the next power-on reset (POR) of the processor. If you make dynamic I/O changes without:

- Making the same changes to the IOCP source file,
- Generating and writing a new IOCDS file to the SE hard disk,
- Making that IOCDS file the active file,

and someone performs a POR, you will lose all of your dynamic I/O changes.

***How to Circumvent This Problem:*** Use the “Lock-Step” method while making dynamic I/O changes, not the “Plug 'n' Play” method.

## The Lock-Step Philosophy

### Recommendation

We strongly recommend that you use the Lock-Step method while making dynamic I/O changes. This method enables you to ensure that:

- All dynamic I/O changes conform to the hardware I/O configuration rules
- The I/O configuration you create is saved and automatically available for use during the next power-on reset of the processor (scheduled or unscheduled).

The Lock-Step philosophy requires you to make permanent changes to the processor's I/O configuration as you dynamically change the I/O configuration on a running system.

The Lock-Step philosophy is:

1. Plan the changes to your I/O configuration.
2. Update your IOCP source file with the planned changes.
3. Validate the IOCP source file for incompatibilities and other errors by running the updated IOCP source file through the IOCP utility on the CMS system disk.

**Note:** Specify all the options you normally specify, except the “WRTxx” option, which writes the generated IOCDS file to the support element (SE) hard disk. Instead, use the NOWRT option.

- If there are no errors, continue to the next step
  - If there are errors, update the IOCP source file and validate it again.
4. Update your software I/O configuration and the hardware's (HSA) view of the I/O configuration by issuing the appropriate CP dynamic I/O commands that correspond to the changes you made in Step 2. (For descriptions of the dynamic I/O commands, see the *z/VM: CP Commands and Utilities Reference*.)

**Note:** Using the dynamic I/O commands that are equivalent to the IOCP changes is **vital** to ensure that the new IOCDS file matches the dynamic I/O changes.

5. Write your updated I/O configuration to the support element (SE) hard disk by running the updated IOCP source file through the IOCP utility on the CMS system disk.

**Note:** Specify all the options you normally specify, including the “WRTxx” option (which writes the newly-generated IOCDS file to the SE hard disk), and also specify the DYN option (to define the hardware configuration token).

6. Make the newly-generated IOCDS file the active IOCDS file using the CP SET IOCDS\_ACTIVE command:

```
set iocds_active xx
```

where *xx* is the 2-digit string (in the range A0 through A3) you specified on the “WRTxx” option of the IOCP utility. The processor will use this active IOCDS file during the next power-on reset (POR).

See *Support Elements Operations Guide*, SC28-6802 for hardware configuration information.

Following the Lock-Step process prevents the hardware and software I/O configurations from becoming mismatched. If a mismatch were to occur and you

## Potential Problems

needed to perform a power-on reset of the processor, neither the IOCP source file nor z/VM would have the changes you made using the z/VM dynamic I/O commands.

---

## Lost In SubSpace

Some control units (for example, 3990s) can generate unsolicited subsystem status and choose a device address (to return status to) without knowing whether the device is defined to the processor. If you define the control unit and a partial list of the I/O devices (that is, you have not defined some of the devices or you have deleted some of the devices), you will lose unsolicited subsystem status reported on those device addresses that you have not yet defined (or have deleted) to the processor. CP must have a real device control block (RDEV) associated with every I/O device associated with that control unit in order to prevent the loss of subsystem-status information.

**How to Circumvent This Problem:** When performing dynamic I/O operations on control units, make sure that you:

- Define all of the I/O devices associated with that control unit (using the CP DEFINE DEVICE command) before bringing them online.

If the channel paths are:

- Online when you are defining the I/O devices and the I/O devices are being defined to a z/VM system that is set up to initialize new devices as they are added to a running system, CP initializes the devices and brings them online.
- Online and the I/O devices are being defined to a z/VM system that is not set up to initialize new devices, you must vary the I/O devices online manually, using the CP VARY (Real Device) command.
- Online, but the I/O devices are being defined to another logical partition where the operating system is not z/VM, consult the documentation for that operating system for information about whether the I/O devices are brought online automatically or manually.
- Offline when you are defining the I/O devices, you must vary the channel paths online manually, using the CP VARY CHPID command. If your z/VM system is:
  - Set up to initialize new devices as they are added to a running system, CP initializes the devices and brings them online.
  - Not set up to initialize new devices as they are added to a running system, you must vary the I/O devices online manually, using the CP VARY (Real Device) command.

**Note:** To tell CP to initialize new devices as they are added to a running system, use the CP SET NEW\_DEVICES INITIALIZE\_WHEN\_ADDED ON command or add a FEATURES ENABLE NEW\_DEVICES\_INITIALIZED\_WHEN\_ADDED statement to your system configuration file.

- Take all of the I/O devices associated with that control unit offline before deleting them. That is, you must:
  1. Vary the I/O devices offline manually, using the CP VARY (Real Device) command
  2. Vary the subchannels offline manually, using the CP VARY SUBCHANNEL command.
  3. Delete the I/O devices using the CP DELETE DEVICE command.

That is, use one dynamic I/O command to define or delete all of the I/O devices associated with that control unit.

---

## Keep It All Together

If you try to activate Open Systems Adapter (OSA) devices before defining all the channel paths, control units, and I/O devices associated with them, unpredictable results may occur.

**How to Circumvent This Problem:** For OSA devices, define the channel path, control unit, and I/O devices in unison before trying to activate them. The best way to accomplish this is using the CP SET CONFIGMODE command.

When you issue a single dynamic I/O command, CP puts you in a state called configuration mode (or “config mode”), processes the dynamic I/O command, and then takes you out of configuration mode. Configuration mode is a machine state that is used to change your I/O configuration dynamically.

Instead of waiting for CP to turn configuration mode on, you can do it yourself using the SET CONFIGMODE command. Then, you can issue all of the dynamic I/O commands necessary for defining your OSA devices. CP will not try to activate the OSA devices until you issue the SET CONFIGMODE command again to leave configuration mode. That is, enter:

```
set configmode on
System is now in configuration mode
Ready;
:
:
:
(Define all your OSA channel paths)
:
:
:
(Define all your OSA control units)
:
:
:
(Define all your OSA I/O devices)
:
:
:
set configmode off
System is no longer in configuration mode
Ready;
```

## Potential Problems

---

## Chapter 24. Sample I/O Configuration Program File

The following is a sample IOCP source file for a system with a 2097 processor. For more information about IOCP files, see the IOCP manual of your specific processor.

```
*
ID          MSG1='LPAR Mode IOCP for 2097 Processor,',          X
           MSG2='Partitions, CAMBVM3 & CAMBVM4 - 36 CHPIDs',    X
           SYSTEM=(2097,1),                                     X
           TOK=('VM-TOKEN',F0F661F1F161F0F9F0F97AF0F47AF4F9404040X
           ,00000000,'06/23/09','10:50:43','','')
*
RESOURCE PARTITION=((CSS(0),(CAMBVM3,1),(CAMBVM4,2)))
*
CHPID PCHID=100,PATH=(00),TYPE=CVC,PART=(CAMBVM3)
CHPID PCHID=101,PATH=(01),TYPE=CVC,PART=(CAMBVM4)
CHPID PCHID=102,PATH=(02),TYPE=CVC,PART=(CAMBVM3)
CHPID PCHID=103,PATH=(03),TYPE=CVC,PART=(CAMBVM4,REC)
CHPID PCHID=104,PATH=(04),TYPE=CVC,PART=(CAMBVM3,REC)
CHPID PCHID=105,PATH=(05),TYPE=CVC,PART=(CAMBVM3,REC)
CHPID PCHID=106,PATH=(06),TYPE=CVC,PART=(CAMBVM3,REC)
CHPID PCHID=107,PATH=(07),TYPE=CVC,PART=(CAMBVM3,REC)
CHPID PCHID=108,PATH=(08),TYPE=CVC,PART=(CAMBVM3,REC)
CHPID PCHID=109,PATH=(09),TYPE=CVC,PART=(CAMBVM3,REC)
CHPID PCHID=10A,PATH=(0A),TYPE=CVC,PART=(CAMBVM3,REC)
CHPID PCHID=10B,PATH=(0B),TYPE=CVC,PART=(CAMBVM4,REC)
CHPID PCHID=10C,PATH=(0C),TYPE=CVC,PART=(CAMBVM4,REC)
CHPID PCHID=10D,PATH=(0D),TYPE=CVC,PART=(CAMBVM3,REC)
CHPID PCHID=10E,PATH=(0E),TYPE=CVC,PART=(CAMBVM3,REC)
CHPID PCHID=10F,PATH=(0F),TYPE=CVC,PART=(CAMBVM3,REC)
CHPID PCHID=110,PATH=(10),TYPE=CVC,PART=(CAMBVM3,REC)
CHPID PCHID=111,PATH=(11),TYPE=CVC,PART=(CAMBVM3,REC)
CHPID PCHID=112,PATH=(12),TYPE=CVC,PART=(CAMBVM3,REC)
CHPID PCHID=113,PATH=(13),TYPE=CVC,PART=(CAMBVM3,REC)
CHPID PCHID=115,PATH=(15),TYPE=CVC,PART=(CAMBVM3,REC)
CHPID PCHID=116,PATH=(16),TYPE=CVC,PART=(CAMBVM3,REC)
CHPID PCHID=117,PATH=(17),TYPE=CVC,PART=(CAMBVM4)
CHPID PCHID=118,PATH=(18),TYPE=CNC,SHARED
CHPID PCHID=119,PATH=(19),TYPE=CNC,SWITCH=01,PART=(CAMBVM3)
CHPID PCHID=11A,PATH=(1A),TYPE=CVC,PART=(CAMBVM3,REC)
CHPID PCHID=11B,PATH=(1B),TYPE=CNC,SWITCH=01,PART=(CAMBVM3)
CHPID PCHID=11C,PATH=(1C),TYPE=CNC,SWITCH=01,PART=(CAMBVM4)
CHPID PCHID=11D,PATH=(1D),TYPE=CVC,SWITCH=01,PART=(CAMBVM3,REC)
CHPID PCHID=11E,PATH=(1E),TYPE=CNC,SWITCH=01,PART=(CAMBVM4)
CHPID PCHID=11F,PATH=(1F),TYPE=CVC,PART=(CAMBVM3,REC)
CHPID PCHID=120,PATH=(2C),TYPE=CNC,PART=(CAMBVM3)
CHPID PCHID=125,PATH=(2D),TYPE=CNC,SHARED
CHPID PCHID=126,PATH=(2E),TYPE=CNC,SWITCH=01,PART=(CAMBVM3)
CHPID PCHID=127,PATH=(2F),TYPE=CNC,SWITCH=01,PART=(CAMBVM3)
*****
***
***          C O N T R O L   U N I T S          ***
***
*****
*****
CNTLUNIT CUNUMBR=140,PATH=(01),SHARED=Y,UNIT=3274,          X
         UNITADD=((40,32))
CNTLUNIT CUNUMBR=0300,PATH=(03),SHARED=N,UNIT=3480,          X
         UNITADD=((00,16))
CNTLUNIT CUNUMBR=480,PATH=(04),SHARED=N,UNIT=3088,          X
         UNITADD=((80,64))
```

## Sample IOCP File

```

CNTLUNIT CUNUMBR=600,PATH=(06),SHARED=N,UNIT=3088, X
        UNITADD=((00,32))
CNTLUNIT CUNUMBR=700,PATH=(07),SHARED=N,UNIT=3088, X
        UNITADD=((00,32))
CNTLUNIT CUNUMBR=8E0,PATH=(08),SHARED=Y,UNIT=3274, X
        UNITADD=((E0,32))
CNTLUNIT CUNUMBR=B00,PATH=(0B),SHARED=N,UNIT=3088, X
        UNITADD=((00,128))
CNTLUNIT CUNUMBR=D80,PATH=(0D),SHARED=N,UNIT=3088, X
        UNITADD=((80,64))
CNTLUNIT CUNUMBR=DC0,PATH=(0D),SHARED=N,UNIT=3088, X
        UNITADD=((C0,64))
CNTLUNIT CUNUMBR=E0E,PATH=(0E),SHARED=N,UNIT=6262, X
        UNITADD=((0E))
CNTLUNIT CUNUMBR=F10,PATH=(0F),SHARED=N,UNIT=AFP1, X
        UNITADD=((10,1))
CNTLUNIT CUNUMBR=11A0,PATH=(11),SHARED=Y,UNIT=3274, X
        UNITADD=((A0,32))
CNTLUNIT CUNUMBR=11C0,PATH=(11),SHARED=Y,UNIT=3274, X
        UNITADD=((C0,32))
CNTLUNIT CUNUMBR=1400,PATH=(14),SHARED=N,UNIT=3088, X
        UNITADD=((00,64))
CNTLUNIT CUNUMBR=1500,PATH=(15),SHARED=N,UNIT=3088, X
        UNITADD=((00,64))
CNTLUNIT CUNUMBR=1700,PATH=(17),SHARED=N,UNIT=3490, X
        UNITADD=((00,16))
CNTLUNIT CUNUMBR=1800,PATH=(18),UNIT=SCTC, X
        UNITADD=((00,64))
CNTLUNIT CUNUMBR=1900,PATH=(19,1B,2E,2F),LINK=(F4,F5,F6,F7), X
        UNITADD=((00,64)),UNIT=3990
CNTLUNIT CUNUMBR=1C00,PATH=(1C,1E),LINK=(F1,F2), X
        UNITADD=((00,64)),UNIT=3990
CNTLUNIT CUNUMBR=1A00,PATH=(1A),SHARED=N,UNIT=3088, X
        UNITADD=((00,64))
CNTLUNIT CUNUMBR=1A40,PATH=(1A),SHARED=N,UNIT=3088, X
        UNITADD=((40,64))
CNTLUNIT CUNUMBR=1A80,PATH=(1A),SHARED=N,UNIT=3088, X
        UNITADD=((80,64))
CNTLUNIT CUNUMBR=1AC0,PATH=(1A),SHARED=N,UNIT=3088, X
        UNITADD=((C0,64))
CNTLUNIT CUNUMBR=1B00,UNIT=SWCH,UNITADD=((00,1)), X
        PATH=(19,1B,2E,2F),LINK=(FE,FE,FE,FE)
CNTLUNIT CUNUMBR=2D00,PATH=(2D),UNIT=3490, X
        UNITADD=((00,16))
CNTLUNIT CUNUMBR=2F00,PATH=(19,1B,2E,2F),LINK=(F8,F9,FA,FB), X
        UNITADD=((00,64)),UNIT=3990
CNTLUNIT CUNUMBR=3000,PATH=(1D),LINK=(F3),UNIT=3480, X
        UNITADD=((00,16)),SHARED=N
CNTLUNIT CUNUMBR=3100,PATH=(19,1B),LINK=(EE,EF), X
        UNITADD=((00,32)),UNIT=3990
*****
***                                     ***
***                               I / O   D E V I C E S                               ***
***                                     ***
*****
*****
IODEVICE ADDRESS=(140,32),CUNUMBR=140,UNIT=3279,MODEL=3
IODEVICE ADDRESS=(0300,16),CUNUMBR=0300,UNIT=3480
IODEVICE ADDRESS=(480,64),CUNUMBR=480,UNIT=3088
IODEVICE ADDRESS=(600,32),CUNUMBR=600,UNIT=3088
IODEVICE ADDRESS=(700,32),CUNUMBR=700,UNIT=3088
IODEVICE ADDRESS=(8E0,7),CUNUMBR=8E0,UNIT=3279,MODEL=3
IODEVICE ADDRESS=(8E7,1),CUNUMBR=8E0,UNIT=3287
IODEVICE ADDRESS=(8E8,7),CUNUMBR=8E0,UNIT=3279,MODEL=3
IODEVICE ADDRESS=(8EF,1),CUNUMBR=8E0,UNIT=3287
IODEVICE ADDRESS=(8F0,16),CUNUMBR=8E0,UNIT=3279,MODEL=3
IODEVICE ADDRESS=(B00,128),CUNUMBR=B00,UNIT=3088

```

```
IODEVICE ADDRESS=(D80,64),CUNUMBR=D80,UNIT=3088
IODEVICE ADDRESS=(DC0,64),CUNUMBR=DC0,UNIT=3088
IODEVICE ADDRESS=(E0E),CUNUMBR=E0E,UNIT=6262
IODEVICE ADDRESS=(F10,1),CUNUMBR=F10,UNIT=AFP1,MODEL=0
IODEVICE ADDRESS=(11A0,32),CUNUMBR=11A0,UNIT=3278,MODEL=2
IODEVICE ADDRESS=(11C0,32),CUNUMBR=11C0,UNIT=3278,MODEL=2
IODEVICE ADDRESS=(1400,64),CUNUMBR=1400,UNIT=CTC
IODEVICE ADDRESS=(1500,64),CUNUMBR=1500,UNIT=CTC
IODEVICE ADDRESS=(1700,16),CUNUMBR=1700,UNIT=3490
IODEVICE ADDRESS=(1800,64),CUNUMBR=1800,UNIT=CTC
IODEVICE ADDRESS=(1900,64),CUNUMBR=(1900),UNIT=3390,UNITADD=00
IODEVICE ADDRESS=(1C00,64),CUNUMBR=(1C00),UNIT=3390,UNITADD=00
IODEVICE ADDRESS=(1A00,64),CUNUMBR=1A00,UNIT=3088
IODEVICE ADDRESS=(1A40,64),CUNUMBR=1A40,UNIT=3088
IODEVICE ADDRESS=(1A80,64),CUNUMBR=1A80,UNIT=3088
IODEVICE ADDRESS=(1AC0,64),CUNUMBR=1AC0,UNIT=3088
IODEVICE CUNUMBR=1B00,ADDRESS=1B00,UNIT=SWCH
IODEVICE ADDRESS=(2D00,16),CUNUMBR=2D00,UNIT=3490
IODEVICE ADDRESS=(2F00,64),CUNUMBR=(2F00),UNIT=3390,UNITADD=00
IODEVICE ADDRESS=(3000,16),CUNUMBR=3000,UNIT=3480
IODEVICE ADDRESS=(3100,32),CUNUMBR=(3100),UNIT=3380,UNITADD=00
```

## Sample IOCP File

---

## Chapter 25. Understanding Dynamic I/O Return Codes

This chapter lists the dynamic I/O return codes that you can receive when using z/VM's dynamic I/O commands. These return codes are the result of errors detected by the processor hardware.

**Note:** You should not see any return codes other than the ones listed below. If you do, please contact your IBM Support Center for assistance.

The following table lists the error messages and CP commands that generate the return codes:

Page	Message	Command
336	HCP6806E	DEFINE CHPID
342	HCP6806E	DEFINE CNTLUNIT
342	HCP6806E	DEFINE CU
350	HCP6806E	DEFINE DEVICE
350	HCP6806E	DEFINE IODEVICE
358	HCP6806E	DEFINE LPAR
336	HCP6806E	DEFINE PATH
356	HCP6806E	DEFINE PCIFunction
336	HCP6806E	DELETE CHPID
342	HCP6806E	DELETE CNTLUNIT
342	HCP6806E	DELETE CU
350	HCP6806E	DELETE DEVICE
350	HCP6806E	DELETE IODEVICE
358	HCP6806E	DELETE LPAR
336	HCP6806E	DELETE PATH
356	HCP6806E	DELETE PCIFunction
336	HCP6806E	MODIFY CHPID
342	HCP6806E	MODIFY CNTLUNIT
342	HCP6806E	MODIFY CU
350	HCP6806E	MODIFY DEVICE
350	HCP6806E	MODIFY IODEVICE
336	HCP6806E	MODIFY PATH
356	HCP6806E	MODIFY PCIFunction
364	HCP6813E	QUERY CHPIDS
365	HCP6849E	QUERY HSA
362	HCP6806E	SET CONFIGMODE
360	HCP6812E	SET IOCDS_ACTIVE
362	HCP6806E	SET LSYSTEM
365	HCP6811E	VARY OFFLINE CHPID
367	HCP6811E	VARY ONLINE CHPID

## Return Codes

The following are HCD ACTIVATE (CBDSACT REXX Utility) error messages that have hardware response codes (note that the hardware response codes correspond to the Dynamic I/O return codes):

Message	Operation Corresponding to Command
CBDD802I	SET IOCDS_ACTIVE
CBDD805I	SET CONFIGMODE
CBDD806I	DEFINE, DELETE OR MODIFY REQUEST FOR DEVICE, CONTROL UNIT, CHPID, MESSAGE DEVICE OR MESSAGE PROCESSOR
CBDD807I	DEFINE, DELETE OR MODIFY REQUEST FOR DEVICE, CONTROL UNIT, CHPID, MESSAGE DEVICE OR MESSAGE PROCESSOR

For more information on these messages, see *z/OS and z/VM: Hardware Configuration Definition Messages*.

---

## Adding, Deleting, or Changing a Channel Path

### Message:

HCP6806E

### Commands:

DEFINE CHPID  
 DEFINE PATH  
 DELETE CHPID  
 DELETE PATH  
 MODIFY CHPID  
 MODIFY PATH

Return Code	Is Issued When:	What You Can Do:
0002 0003 0004	One of the following occurred: 1. You requested a function or specified an operand that is not available in your processor. 2. There was an internal programming error in z/VM.	1. Your z/VM system is at a more-advanced level than your processor. Use only functions and operands supported by your processor. 2. Call IBM for service on your z/VM operating system.
0008	The specified channel subsystem identifier and/or reference channel subsystem identifier is not a valid channel subsystem identifier in your configuration.	Issue the Query LPARS command to determine which channel subsystem images are defined in your configuration and reissue the command with valid channel subsystem identifiers.
0103	One of the following occurred: 1. You specified a CHPID-type that is not supported by your processor or that is supported by your processor but is not dynamically configurable. 2. On an EMIF-capable processor, you tried to define a shared channel path but did not specify a TYPE of CBP, CBS, CFP, CFS, CNC, CTC, DSD, EIO, FC, FCP, FCV, ICP, IQD, ISD, OSA, OSC, OSD, OSE or OSN.	1. Verify the actual CHPID-type installed on your processor, and that the CHPID-type is supported and is dynamically configurable by your processor. 2. Only the channel paths listed at the left can be shared. Verify and change your request according to the type of channel path installed on your processor.

Return Code	Is Issued When:	What You Can Do:
0104	One of the following occurred: <ol style="list-style-type: none"> <li>1. On an EMIF-capable processor, you incorrectly used the operands for non-EMIF-capable processors in LPAR mode.</li> <li>2. On a non-EMIF-capable processor, you incorrectly used the operands for EMIF-capable processors.</li> </ol>	<ol style="list-style-type: none"> <li>1. Reissue the command using the correct operands for EMIF-capable-processors.</li> <li>2. Reissue the command using the correct operands for non-EMIF-capable processors.</li> </ol>
0105	You tried to add a FICON_CONVerter channel (FCV), but you did not specify a SWITCH value.	Reissue the command with a SWITCH value specified.
0106	You tried to add a channel path, but the channel path identifier (CHPID) you chose is already defined in the I/O configuration.	Verify the channel path identifier that you are trying to define. If you typed it correctly, choose a different channel path ID that does not conflict with an existing channel path.
0107	One of the following occurred: <ol style="list-style-type: none"> <li>1. You tried to define, delete, or change a channel path, but one or more of the logical partitions that you specified is not currently defined in the active I/O configuration.</li> <li>2. Your processor is EMIF-capable and:               <ol style="list-style-type: none"> <li>a. You tried to add a channel path or change an existing channel path by adding access to one or more logical partitions, and one or more logical partitions were defined in the initial access list that were not defined in the access list.</li> <li>b. You tried to change an existing channel path by deleting one or more logical partitions from the access list, but one or more of the specified logical partitions do not have access to the channel path.</li> <li>c. You tried to add a nonshared channel path or change an existing nonshared channel path by adding access to one or more logical partitions, and more than one logical partition was specified as having initial access.</li> <li>d. You tried to change an existing channel path that was originally defined as a dedicated, nonreconfigurable channel path.</li> <li>e. You tried to add a dedicated, nonreconfigurable channel path with access to more than one logical partition.</li> </ol> </li> </ol>	<ol style="list-style-type: none"> <li>1. Issue the CP QUERY LPARS command to display the list of logical partitions defined on the processor. If the logical partition is on the list, please contact your IBM Support center for assistance.</li> <li>2.               <ol style="list-style-type: none"> <li>a. Reissue the command, making sure the logical partitions in the initial access list are a subset of the ones in the access list.</li> <li>b. Verify which logical partitions have access to the channel path and issue the command again, accordingly.</li> <li>c. Issue the command again and specify only one logical partition on the initial access list.</li> <li>d. Delete the channel path and define it again as a reconfigurable channel path.</li> <li>e. Issue the command again and specify only one logical partition in the access list.</li> </ol> </li> </ol>
0108	On an EMIF-capable processor, you specified a TYPE of ISD as being dedicated and reconfigurable.	An ISD channel path must be defined as dedicated and nonreconfigurable or as shared. Verify and change your request accordingly.

## Return Codes

Return Code	Is Issued When:	What You Can Do:
010A	You tried to delete a channel path (or if you are on EMIF-capable processor, you might have been trying to modify an existing channel path), but the channel path you specified is not defined in the I/O configuration.	Issue the CP QUERY CHPIDS command to display the channel paths defined in the I/O configuration.
010B	You tried to delete a channel path, but this channel path still has one or more control units defined for it.	Delete the control units attached to the channel path first, then issue the command again.
010C	You tried to delete a channel path, but the channel path that you specified is the only channel path defined for one or more logical partitions.	Go to the hardware channel configuration frame to display all the channel paths in all the logical partitions. (The QUERY CHPIDS command will only show you the channel paths in the logical partition from which it is issued.)
010D	You tried to add, delete, or change a channel path, but one of the following occurred: <ol style="list-style-type: none"> <li>You tried to add a channel path, or add access to a channel path, for a coupling facility logical partition.</li> <li>Your processor does not support the dynamic I/O configuration change that you requested.</li> </ol>	<ol style="list-style-type: none"> <li>On some models you cannot define channel paths for a coupling facility logical partition. Verify the partitions for which you are defining the channel path and issue the command again.</li> <li>Verify the change that you are trying to make. If you believe the requested change is valid, contact your IBM Support Center for assistance.</li> </ol>
010F	You tried to delete a channel path, but one of the following conditions prevented the successful completion of the command: <ol style="list-style-type: none"> <li>The channel path you specified is in a state that prevents it from being deleted.</li> <li>The channel path you specified is configured online to one or more other logical partitions, and the system's attempt to deconfigure the channel path from that (those) logical partition(s) was unsuccessful.</li> <li>The channel path you specified is an ICP channel path and is associated with a peer ICP channel path that is configured online to one or more logical partitions, and the system's attempt to deconfigure the channel path from that (those) logical partition(s) was unsuccessful.</li> </ol>	<ol style="list-style-type: none"> <li>Verify the change that you were trying to make. If you believe the requested change was valid, contact your IBM Support Center for assistance.</li> <li>Configure the channel path offline in all logical partitions for which you are attempting to delete access. If you are successful, reissue this command.</li> <li>Determine the peer channel path for the path you are trying to delete, and configure that peer path offline in all logical partitions. If you are successful, reissue this command.</li> </ol>
0110	One of the following occurred: <ol style="list-style-type: none"> <li>The processor is temporarily unable to make the dynamic I/O configuration change that you requested.</li> <li>You issued a MODIFY CHPID command on an EMIF-capable processor to request conditional deletion of access by one or more logical partitions to the specified channel path. However, the channel path is currently being used by one or more of those logical partitions.</li> </ol>	<ol style="list-style-type: none"> <li>After waiting a short period of time for the processor to complete the internal functions that prevented this command from working the first time, issue the dynamic I/O command again.</li> <li>Vary the channel path offline in the affected logical partitions, thereby making the channel path unavailable. Issue the CP MODIFY CHPID command again to conditionally delete access by the logical partitions.</li> </ol>

Return Code	Is Issued When:	What You Can Do:
0111	The dynamic I/O configuration change that you requested would result in an ambiguous I/O configuration or an I/O configuration that is not valid.	Verify the change that you are trying to make. If you believe the requested change is valid, contact your IBM Support Center for assistance.
0112	<p>One of the following occurred:</p> <ol style="list-style-type: none"> <li>1. The specified channel path, if added to your configuration, would exceed the maximum number of coupling-facility-related sender channels (of all types) that can be configured to your machine.</li> <li>2. The specified channel path, if added to your configuration, would exceed the maximum number of coupling-facility-related channels (of all types sender, receiver, and peer channels) that can be configured to your machine.</li> <li>3. The specified channel path, if added to your configuration, would exceed the maximum number of internal-queued-direct-communication channels that can be configured to your machine.</li> </ol>	<ol style="list-style-type: none"> <li>1. Ensure that your desired configuration fits within the limits of your machine and reissue dynamic I/O configuration commands accordingly.</li> <li>2. Ensure that your desired configuration fits within the limits of your machine and reissue dynamic I/O configuration commands accordingly.</li> <li>3. Ensure that your desired configuration fits within the limits of your machine and reissue dynamic I/O configuration commands accordingly.</li> </ol>
0114	You tried to define an ESCON (CNC), FICON™ (FC), or FICON Converter (FCV) channel path as a managed channel path but the path is not a shared path or is not a switched path.	A managed channel path must be a switched, shared ESCON, FICON, or FICON Converter channel path. You can reissue the command to define the path as shared if it is unshared. If the path is not a switched path, do not attempt to define it as a managed path.
0115	You tried to define a channel path as a managed channel path within an I/O cluster, and the I/O cluster name was a new name that would have caused the processor to exceed its limit for defined I/O cluster names.	Your processor does not support the number of I/O-cluster names you attempted to create. You can define the channel path in an already-defined I/O cluster if that meets your requirements, but another I/O cluster cannot be created.
0116	You tried to define a channel path as a managed channel path, but the channel-path type was not ESCON (CNC), FICON (FC), or FICON Converter (FCV).	Verify that the channel path being defined is the correct type for a managed channel path; otherwise, do not attempt to define the channel path as a managed path.

## Return Codes

Return Code	Is Issued When:	What You Can Do:
0119	<p>One of the following occurred:</p> <ol style="list-style-type: none"> <li>1. The addition of the specified DSD, EIO, FC, FCP, FCV, IQD, OSD, or OSE channel would exceed the channel subsystem's overall limit for the collection of all such channels.</li> <li>2. The addition of the specified DSD, EIO, OSA, OSD, or OSE channel would exceed the channel subsystem's overall limit for the collection of all such channels.</li> <li>3. The addition of the specified FC, FCP or FCV channel would exceed the channel subsystem's overall limit for the collection of all such channels.</li> <li>4. The addition of the specified FCP, OSC, OSD, OSE, or OSN channel would exceed the channel subsystem's overall limit for the collection of all such channels.</li> <li>5. The addition of the specified OSC, OSD, OSE, OSM, OSN, or OSX channel would exceed the channel subsystem's overall limit for the collection of all such channels.</li> </ol>	<ol style="list-style-type: none"> <li>1. Consult the System Library publication for your processor and make sure the total number of channels of the types mentioned at left does not exceed the limit for your processor.</li> <li>2. See (1) above, noting that the list of channel types in (1), (2), (3), (4), and (5) at left represents different limits in the same processor, although some of the channel path types overlap between categories (1), (2), (3), (4), and (5).</li> <li>3. See (2) above.</li> <li>4. See (2) above.</li> <li>5. See (2) above.</li> </ol>
011A	<p>You tried to add an internal coupling peer (ICP) channel path and you specified a peer path (that is, the ICP path that is supposed to be connected to the ICP path being defined), but the peer path was not appropriate for one of the following reasons:</p> <ul style="list-style-type: none"> <li>• <ol style="list-style-type: none"> <li>1. The peer path is not defined in the I/O configuration.</li> <li>2. The peer path is not an ICP channel path.</li> <li>3. The peer path is the same channel path as the ICP path being defined.</li> <li>4. The peer path is already associated with another ICP path.</li> </ol> </li> </ul>	<p>Verify the peer path that is actually connected to the ICP path being defined and reissue the command to create the proper association.</p>
011B	<p>The specified channel path is not available to be added to the I/O configuration.</p>	<p>Verify the change that you are trying to make. If you believe the requested change is valid, contact your IBM support center.</p>
011C	<p>The specified physical channel identifier (PCHID) is not a valid PCHID in your configuration or was not specified when required.</p>	<p>Verify the change that you are trying to make and specify the proper physical channel identifier for the channel path you are adding.</p>
011D	<p>You tried to add a channel path to your configuration, but the specified physical channel identifier (PCHID) is already defined in your configuration.</p>	<p>Verify the change that you are trying to make and specify the proper physical channel identifier for the channel path you are adding.</p>

Return Code	Is Issued When:	What You Can Do:
011E	You tried to modify a channel path to add it to an additional channel subsystem image, and either the channel path is not capable of being shared across multiple logical channel subsystem images (i.e., it is not spannable) on your machine model or you did not define the channel path as sharable.	If the channel path is a type that is spannable on your machine model and you mean to share it across multiple logical channel subsystem images, you must re-define the channel path as a shared channel path (i.e., the channel path must be completely deleted from your configuration and then added back as a shared channel path).
011F	You tried to modify a channel path to add it to an additional channel subsystem image, but you specified the same value for the channel subsystem identifier and the reference channel subsystem identifier.	Verify the change you are trying to make and reissue the command, specifying the additional channel subsystem image as the channel subsystem identifier and an existing channel subsystem image for the channel path as the reference channel subsystem identifier (i.e., the channel subsystem image from which channel path attributes are to be copied).
0120	You tried to modify a channel path to remove it from a channel subsystem image, but there is only one channel subsystem image in which the channel path is defined.	The MODIFY command can be used to remove a channel path from one of two or more channel subsystem images in which the channel path is defined, but this command cannot be used to remove a channel path from the last (or only) channel subsystem image in which the channel path is defined. Use the DELETE command to remove the channel path completely from your configuration when the channel path is defined only in one channel subsystem image.
0121	You tried to delete a channel path from your configuration, but the channel path is defined in more than one channel subsystem image.	The DELETE command can be used to remove a channel path from your configuration when the channel path is defined only in one channel subsystem image of a multiple logical channel subsystem configuration. Use the MODIFY command to remove the channel path from all but one of the channel subsystem images, and then reissue the DELETE command to remove the channel path completely from your configuration.
0122	You tried to define a channel path of a certain type, but an associated parameter that was specified is not valid on your processor.	Reissue the command with only valid parameters for your processor.
012C	The specified virtual channel identifier (VCHID) is not a valid VCHID in your configuration or was not specified when required.	Verify the change that you are trying to make and specify the proper virtual channel identifier for the channel path you are adding.
012D	The specified virtual channel identifier (VCHID) is a valid VCHID but has already been used in your configuration.	Verify the change that you are trying to make and specify a new virtual channel identifier for the channel path you are adding.

## Return Codes

Return Code	Is Issued When:	What You Can Do:
0130	<p>You tried to define a coupling over InfiniBand (CIB) channel path and one of the following occurred:</p> <ol style="list-style-type: none"> <li>1. The adapter identifier (AID) specified on the command was invalid or unrecognized by your machine.</li> <li>2. The port number (PORT) specified on the command was invalid or unrecognized by your machine.</li> <li>3. The port number (PORT) specified on the command was valid but is not available for use by a CIB channel path.</li> </ol>	<ol style="list-style-type: none"> <li>1. Issue the command again specifying an AID that is valid for your machine.</li> <li>2. Issue the command again specifying a port number that is valid for your machine.</li> <li>3. Issue the command again specifying a port number that is available for use by a CIB channel path.</li> </ol>
0131	<p>You tried to define the second path of a pair of coupling over InfiniBand (CIB) channel paths connecting to each other on the same system, but the peer-path information on the command did not refer back to the first CIB path.</p>	<p>Verify the peer path that is actually connected to the CIB path being defined and reissue the command to create the proper association.</p>
0132	<p>You tried to add a coupling over InfiniBand (CIB) channel path and you specified a peer path (that is, the CIB path that is supposed to be connected to the CIB path being defined), but the peer path was not appropriate for one of the following reasons:</p> <ol style="list-style-type: none"> <li>1. The peer path is not a CIB channel path.</li> <li>2. The peer path is the same channel path as the CIB channel path being defined.</li> <li>3. The peer path is already associated with another CIB path.</li> </ol>	<p>Verify the peer path that is actually connected to the CIB path being defined and reissue the command to create the proper association.</p>
0134	<p>You tried to add a coupling over InfiniBand (CIB) channel path, and one of the following occurred:</p> <ol style="list-style-type: none"> <li>1. The addition of the specified CIB channel would exceed the maximum number of allowed CIB channels on the specified adapter, port, or both.</li> <li>2. The addition of the specified CIB channel would exceed the channel subsystem's resource limit.</li> </ol>	<ol style="list-style-type: none"> <li>1. Consult the System Library publication for your processor and make sure the total number of CIB channels does not exceed the limit for your processor.</li> <li>2. Consult the System Library publication for your processor for guidance on resources needed for defining CIB channel paths.</li> </ol>
0135	<p>You tried to add a coupling over InfiniBand (CIB) channel path and the system name specified in the CSYSstem parameter was invalid.</p>	<p>Verify the system name of the coupled system and reissue the command.</p>

## Adding, Deleting, or Changing a Control Unit

### Message:

HCP6806E

### Commands:

```

DEFINE CU
DEFINE CNTLUNIT
DELETE CU
DELETE CNTLUNIT
MODIFY CU

```

## MODIFY CNTLUNIT

Return Code	Is Issued When:	What You Can Do:
0002 0003 0004	One of the following occurred: <ol style="list-style-type: none"> <li>1. You requested a function or specified an operand that is not available in your processor.</li> <li>2. There was an internal programming error in z/VM.</li> </ol>	<ol style="list-style-type: none"> <li>1. Your z/VM system is at a more-advanced level than your processor. Use only functions and operands supported by your processor.</li> <li>2. Call IBM for service on your z/VM operating system.</li> </ol>
0008	The specified channel subsystem identifier and/or reference channel subsystem identifier is not a valid channel subsystem identifier in your configuration.	Issue the Query LPARS command to determine which channel subsystem images are defined in your configuration and then reissue the command with valid channel subsystem identifiers.
0103	<ol style="list-style-type: none"> <li>1. You tried to add a control unit, but the control unit number that you specified is already defined in the I/O configuration.</li> <li>2. You tried to modify or delete an I/O control unit, but the control unit number specified is associated with a coupling-facility control unit.</li> <li>3. You tried to modify or delete a coupling-facility control unit but the control unit number specified is associated with an I/O control unit.</li> </ol>	<ol style="list-style-type: none"> <li>1. Verify that you have defined duplicate control unit numbers. If you did, choose a different control unit number and issue the dynamic I/O command again. If you did not have a duplicate control unit number (including those for a coupling facility), please contact your IBM Support Center for assistance.</li> <li>2. Verify the control unit that you are trying to modify or delete and issue the command again with the appropriate parameters.</li> <li>3. Verify the control unit that you are trying to modify or delete and issue the command again with the appropriate parameters.</li> </ol>
0104	<p>You tried to add a new or change an existing control unit, but one of the following occurred:</p> <ol style="list-style-type: none"> <li>1. You specified the TYPE_1 or SHARED operand (which means this control unit supports only one I/O request at a time) along with a CHPID or PATH operand that specified a channel path number that was defined as TYPE BYTE (a byte-multiplexor channel, which supports interleaving of more than one I/O request at a time) or TYPE ESCON_CONVERTER_BYTE.</li> <li>2. You specified a type of control unit (TYPE operand) that is inconsistent with one or more of the specified channel paths (CHPID or PATH operand).</li> <li>3. You issued a MODIFY CU command for a control unit attached through an EIO, FCP, IQD, OSA, OSC, OSD, OSE, or OSN channel path.</li> </ol>	<ol style="list-style-type: none"> <li>1. Define the control unit as a TYPE_2 or UNSHARED control unit, or redefine the channel path as TYPE BLOCK or TYPE ESCON_CONVERTER, according to the actual processor and control unit hardware installed.</li> <li>2. Specify a TYPE value that corresponds with the type of channel path (or paths) connected to the control unit.</li> <li>3. Except for the ADD CSS ACCESS and DELETE CSS ACCESS options, the MODIFY CU command does not apply to control units attached through EIO, FCP, IQD, OSA, OSC, OSD, OSE, or OSN channel paths.</li> </ol>

## Return Codes

Return Code	Is Issued When:	What You Can Do:
0105	<p>You tried to add a new or change an existing control unit, but one of the following occurred:</p> <ol style="list-style-type: none"> <li>1. You specified one or more channel paths that are not defined in the I/O configuration.</li> <li>2. In changing a control unit, you specified one or more unswitched ESCON channel paths that already have a control unit with a link address different from the one you specified, or with a control unit logical address that is the same as the one you specified.</li> <li>3. You specified duplicate channel path identifiers.</li> <li>4. You tried to define the control unit with a channel path type or mixture of channel path types that is not supported by your processor.</li> <li>5. You tried to define or modify the I/O or coupling-facility control unit with a mixture of shared and unshared channel paths (including channel path that might be defined in other channel subsystem images).</li> <li>6. You specified a link address and control unit logical address that is already being used by another control unit on the specified channel path.</li> <li>7. You specified a link address of X'00' or X'FF' for use with an ESCON switched channel path.</li> <li>8. You specified a link address of X'FF' for use with an ESCON unswitched channel path.</li> <li>9. You specified ISD channel paths that are dedicated and nonreconfigurable, and they are not all configured to the same logical partition.</li> <li>10. You specified a CUADD value greater than the supported range of values for the type of channel path you are using.</li> <li>11. You specified a control unit type of FICON_CTC; however the channel path you specified is not a FICON channel path.</li> </ol>	<ol style="list-style-type: none"> <li>1. Issue the CP DEFINE CHPID command to define the channel paths, and then issue the CP DEFINE or MODIFY CU command again.</li> <li>2. Issue the command again and either specify a link address that is the same as that already defined for the control unit, or specify a control unit logical address that is different from that already defined for the control unit.</li> <li>3. Issue the command again and specify unique channel path ID numbers.</li> <li>4. Verify that the channel path type or mixture of channel path types is supported by your control unit and processor.</li> <li>5. The channel paths to a control unit must be all shared or all unshared. Reissue the command, specifying channel paths that are consistently shared or unshared with respect to each other and with any channel paths already defined for the control unit in other channel subsystem images.</li> <li>6. Issue the command again and specify a different link address or a different control unit logical address.</li> <li>7. You cannot use a link address of X'00' or X'FF' on ESCON channel paths through an ESCON Director. You must specify an address between X'01' and X'FE'.</li> <li>8. You cannot use a link address of X'FF' on ESCON channel paths. You must specify an address between X'00' and X'FE'.</li> <li>9. The internal control unit in your processor does not support access by more than one logical partition. Verify and change your request to specify the proper channel paths, or correct the definitions of the channel paths such that they are configured to the same logical partition.</li> <li>10. Check the <i>Input/Output Configuration Program User's Guide</i> for the proper range of CUADD values for the channel-path type, and reissue the command with an appropriate CUADD value.</li> <li>11. Issue the command again specifying a channel path that is a FICON channel path.</li> </ol>

Return Code	Is Issued When:	What You Can Do:
0106	<p>You tried to add a new or change an existing control unit, but one of the following occurred:</p> <ol style="list-style-type: none"> <li>1. You tried to add or delete one or more unit addresses, but this dynamic I/O change would result in more than one range of unit addresses for this control unit. That is, there will be a gap between sets of unit addresses. Your processor does not support multiple unit address ranges for the specified control unit in the context of the I/O configuration definition.</li> <li>2. You specified one or more unit addresses for a parallel channel path and the one or more of the unit addresses are not unique to this control unit.</li> <li>3. For a control unit attached through an EIO channel path, you specified a range of unit addresses.</li> <li>4. For a control unit attached through an EIO channel path, you specified a unit address that is not unique within the set of unit addresses recognized by other control units on the same channel path.</li> <li>5. For a control unit attached through an EIO channel path, you specified a unit address of X'FF'.</li> </ol>	<ol style="list-style-type: none"> <li>1. Issue the command again and specify the unit addresses so that the resulting unit addresses form a single numerical range of addresses.</li> <li>2. Issue the command again in such a way that the unit addresses are unique within the set of all unit addresses for all control units on the channel path.</li> <li>3. The control unit attached to your EIO channel path supports only one unit address. Issue the command again with a single unit address.</li> <li>4. Issue the command again with a unit address that is unique within the set of all unit addresses recognized by the control units on the channel path.</li> <li>5. The control unit attached to your EIO channel path does not support a unit address of X'FF'. Issue the command again with a unit address within the range X'00' to X'FE'.</li> </ol>

## Return Codes

Return Code	Is Issued When:	What You Can Do:
0107	<p>You tried to add a new or change an existing control unit, but one of the following occurred:</p> <ol style="list-style-type: none"> <li>1. The range of specified unit addresses, when added to the number of unit address ranges already defined for each of the channel paths, would result in exceeding the limit of unit address ranges allowed for one or more channel paths.</li> <li>2. The number of specified channel paths, when added to the number of channel paths, if any, already defined for the specified control unit, would result in exceeding the limit for the number of channel paths allowed.</li> <li>3. The addition of the control unit would exceed the limit of the number of control units supported by your processor on one or more of the specified channel paths.</li> <li>4. The addition of this control unit would exceed the limit on the number of control units supported by your processor in the I/O configuration.</li> <li>5. The number of specified channel paths, when added to the number of channel paths, if any, already defined for accessing the shared device cluster that includes the specified control unit, would result in exceeding the limit of the number of channel paths allowed.</li> <li>6. One or more of the specified channel paths is already defined as being connected to a different internal or coupling-facility control unit.</li> <li>7. The specified control unit is an internal control unit on ISD channel paths, and the specified number of channel paths is not supported on your machine.</li> <li>8. The number of channel paths (existing or being defined) plus the maximum number of managed channel paths you specified exceeds 8.</li> <li>9. You attempted to modify the maximum number of managed paths for a FICON CTC control unit.</li> <li>10. You specified a control unit type of FICON_CTC; however, you specified more than one channel path.</li> </ol>	<ol style="list-style-type: none"> <li>1. Change the unit addresses in the command so as to reduce the resulting number of address ranges for the control unit's channel paths.</li> <li>2. Change the number of channel paths specified in the command so as to stay within the limits for your control unit and processor.</li> <li>3. Make sure that the number of control units on a given channel path does not exceed 48. Please note, however, that a lower limit applies to some types of control units. See the current <i>Input/Output Configuration Program User's Guide</i> for your processor for specific limits.</li> <li>4. Make sure that the number of control units does not exceed the maximum number allowable in your I/O configuration. see the IOCP manual of your specific processor for more information on the limit.</li> <li>5. Change the number of channel paths specified in the command so as to stay within the limits for your processor.</li> <li>6. Make sure that you are specifying the correct channel paths for the internal or coupling-facility control unit, and reissue the command.</li> <li>7. There are special requirements on the number of channel paths to which the specified type of control unit can attach. Verify and change the number of channel paths and reissue the command.</li> <li>8. Reduce the specified maximum number of managed channel paths such that the total potential number of channel paths to the control unit does not exceed 8, and reissue the command.</li> <li>9. A FICON CTC control unit can be attached only through one channel path and does not support managed channel paths. Verify the control unit number you are specifying and reissue the command if appropriate.</li> <li>10. A FICON CTC control unit can be attached only through one channel path. Reissue the command specifying only one channel path.</li> </ol>

Return Code	Is Issued When:	What You Can Do:
0108	<p>You tried to change an existing control unit, but one of the following occurred:</p> <ol style="list-style-type: none"> <li>1. You tried to add channel path access, but one or more of the specified channel paths were already defined as providing access to the control unit.</li> <li>2. You tried to add one or more unit addresses to the control unit, but some or all of the specified addresses are already defined as being recognized by the control unit.</li> <li>3. You tried to delete one or more channel paths that are not defined to the control unit.</li> <li>4. You tried to delete one or more channel paths, but this would have resulted in the removal of all access to the control unit.</li> <li>5. You tried to delete one or more unit addresses that are not currently defined as being recognized by the control unit.</li> <li>6. You tried to delete one or more unit addresses, but this would have resulted in the removal of all unit addresses from the control unit.</li> <li>7. You tried to delete one or more unit addresses, but one or more of the I/O devices are described as being accessed by one or more of the specified unit addresses.</li> </ol>	<ol style="list-style-type: none"> <li>1. Issue the command again, omitting any channel paths that are already defined as providing access to the control unit.</li> <li>2. Issue the command again, omitting any unit addresses that are already defined as being recognized by the control unit.</li> <li>3. Issue the command again, omitting any channel paths that are not defined as providing access to the control unit.</li> <li>4. You issued a CP MODIFY CU command and asked to delete the last channel path to the control unit. This is not allowed. If you meant to delete the control unit, you must delete all devices first and then issue the CP DELETE CU command.</li> <li>5. Issue the CP MODIFY CU command again after ensuring that the specified unit address range is defined for the control unit.</li> <li>6. You cannot delete all of the unit addresses from a control unit. If you meant to delete the control unit, you must delete all devices first and then issue the CP DELETE CU command.</li> <li>7. Delete the I/O device (or devices) using the CP DELETE DEVICE command, and then issue the CP MODIFY CU command again to delete the unit addresses.</li> </ol>
0109	<p>The processor did not have enough storage in the hardware system area (HSA) to process the dynamic I/O command that you entered.</p>	<p>Issue the CP QUERY DYNAMIC_I/O STORAGE command to display the resources available. If the amount is not sufficient, you can make some HSA available by deleting an existing channel path that is not being used, or you can increase the amount of HSA defined on the CONFIG screen of the support element (SE) and perform a power-on-reset (POR) of the processor.</p>
010A	<p>You tried to delete or change an existing control unit, but the specified control unit is not defined in the I/O configuration.</p>	<p>Verify that the control unit that you specified is the correct one and issue the command again.</p>
010B	<p>You tried to delete a control unit, but this control unit still has one or more I/O devices defined to it.</p>	<p>Delete all of the I/O devices for the control unit and then issue the CP DELETE CU command again.</p>

## Return Codes

Return Code	Is Issued When:	What You Can Do:
<p><b>010D</b></p>	<p>You tried to add, delete, or change a control unit, but one of the following occurred:</p> <ol style="list-style-type: none"> <li>1. For a channel path to which the specified I/O control unit is attached, you exceeded the limit on the number of unit addresses supported for that type of channel path.</li> <li>2. One or more of the specified channel paths for the specified I/O control unit is a coupling-facility channel path.</li> <li>3. One or more of the specified channel paths for the specified coupling-facility control unit is one of several types of coupling-facility-receiver channel paths that is not dynamically changeable on your machine model.</li> <li>4. Your machine model does not support the dynamic-I/O configuration change that you requested.</li> <li>5. One or more of the specified channel paths for the specified coupling-facility control unit is an I/O channel path.</li> <li>6. The combination of coupling-facility channel-path types that would result from the requested change for the specified coupling-facility control unit (including channel-path types defined in other channel subsystem images for the control unit) is not supported on your machine model.</li> </ol>	<ol style="list-style-type: none"> <li>1. Issue the command again with fewer unit addresses if you were not already at the limit for the applicable channel path, or reduce the number of unit addresses configured to other control units on the channel path.</li> <li>2. Coupling-facility channel paths are for coupling-facility control units only. Reissue the command, specifying the proper type(s) of channel path(s) for the I/O control unit.</li> <li>3. On some models, coupling-facility control units in a coupling-facility logical partition can be changed only via the I/O Configuration Program (IOCP). Use the IOCP to make your change and perform a power-on reset of your machine to make the change effective.</li> <li>4. Verify the change that you are trying to make. If you believe the requested change is valid, contact your IBM support center for assistance.</li> <li>5. I/O channel paths are for I/O control units only. Reissue the command, specifying the proper type(s) of channel path(s) for the coupling-facility control unit.</li> <li>6. Determine the allowable mixtures of coupling-facility channel-path types for coupling-facility control units on your machine model and define your configuration accordingly.</li> </ol>
<p><b>0110</b></p>	<p>The processor is temporarily unable to make the dynamic I/O configuration change that you requested.</p>	<p>After waiting a short period of time for the processor to complete the internal functions that prevented this command from working the first time, issue the dynamic I/O command again.</p>
<p><b>0111</b></p>	<p>The dynamic I/O configuration change that you requested would result in an ambiguous I/O configuration or an I/O configuration that is not valid.</p>	<p>Verify the change that you are trying to make. If you believe the requested change is valid, contact your IBM Support Center for assistance.</p>

Return Code	Is Issued When:	What You Can Do:
0113	<ol style="list-style-type: none"> <li>1. Your processor is defined with one or more logical partitions, and you tried to add a new control unit with managed channel paths, but the non-managed channel paths are not shared paths.</li> <li>2. Your processor is defined with one or more logical partitions, and you tried to change the maximum number of managed channel paths for a control unit from zero to a non-zero number, but the non-managed channel paths are not shared paths.</li> <li>3. You tried to add a new control unit with managed channel paths, but one or more of the specified non-managed channel paths is of a type that is not compatible with managed channel paths; that is, the non-managed channel paths are of a type other than ESCON (CNC), FICON (FC), or FICON Converter (FCV).</li> <li>4. You tried to change the maximum number of managed channel paths for a control unit from zero to a non-zero number, but the non-managed channel paths are of a type that is not compatible with managed channel paths; that is, the non-managed channel paths are of a type other than ESCON (CNC), FICON (FC), or FICON Converter (FCV).</li> <li>5. You tried to delete a coupling-facility control unit from your configuration, but the the control unit is defined in more than one channel subsystem image.</li> </ol>	<ol style="list-style-type: none"> <li>1. You can delete and re-define the non-managed channel paths to the control unit as shared channel paths if that meets your requirements; otherwise, do not attempt to use managed channel paths on a control unit with unshared channel paths.</li> <li>2. Do not attempt to use managed channel paths on a control unit with unshared channel paths.</li> <li>3. Do not attempt to use managed channel paths on a control unit unless it is connected to your processor through ESCON, FICON, or FICON Converter channel paths.</li> <li>4. Do not attempt to use managed channel paths on a control unit unless it is connected to your processor through ESCON, FICON, or FICON Converter channel paths.</li> <li>5. The DELEte command can be used to remove a control unit from your configuration when the control unit is defined only in one channel subsystem image of a multiple logical channel subsystem configuration. Use the MODify command to remove the control unit from all but one of the channel subsystem images, and then reissue the DELEte command to remove the control unit completely from your configuration.</li> </ol>
0114	<p>You tried to modify a coupling facility control unit to add it to an additional channel subsystem image, but you specified the same value for the channel subsystem identifier and the reference channel subsystem identifier.</p>	<p>Verify the change you are trying to make and reissue the command, specifying the additional channel subsystem image as the channel subsystem identifier and an existing channel subsystem image for the control unit as the reference channel subsystem identifier (i.e., the channel subsystem image from which control unit attributes are to be copied).</p>
0115	<p>You tried to modify a coupling facility control unit to remove it from a channel subsystem image, but there is only one channel subsystem image in which the control unit is defined.</p>	<p>The MODify command can be used to remove a control unit from one of two or more channel subsystem images in which the control unit is defined, but this command cannot be used to remove a control unit from the last (or only) channel subsystem image in which the control unit is defined. Use the DELEte command to remove the control unit completely from your configuration when the control unit is defined only in one channel subsystem image.</p>
0116	<p>You specified a one- or two-digit link address for a PATH or CHPID when a three- or four-digit link address is required.</p>	<p>Check your configuration and reissue the command with the proper link address.</p>

## Return Codes

Return Code	Is Issued When:	What You Can Do:
0118	You tried to delete an I/O control unit from your configuration, but the control unit is defined in more than one channel subsystem image.	The DELEte command can be used to remove a control unit from your configuration when the control unit is defined only in one channel subsystem image of a multiple logical channel subsystem configuration. Use the MODify command to remove the control unit from all but one of the channel subsystem images, and then reissue the DELEte command to remove the control unit completely from your configuration.
0119	You tried to modify an I/O control unit to add it to an additional channel subsystem image, but the control unit is already defined in the image that you specified.	Verify the change that you are trying to make and specify the correct channel subsystem image in which to add the control unit.
011B	You tried to modify an I/O control unit to remove it from a channel subsystem image, but there is only one channel subsystem image in which the control unit is defined.	The MODify command can be used to remove a control unit from one of two or more channel subsystem images in which the control unit is defined, but this command cannot be used to remove a control unit from the last (or only) channel subsystem image in which the control unit is defined. Use the DELEte command to remove the control unit completely from your configuration when the control unit is defined only in one channel subsystem image.
011C	You tried to add a FICON_CTC control unit, but a non-CTC control unit is already attached to the specified fibre-channel (FC) channel path for the specified destination link address.	Issue the command again, specifying an FC channel path and destination link address that is not already attached to a non-CTC control unit.
0133	You tried to add a new or change an existing coupling control unit (message processor) attached through coupling over InfiniBand (CIB) channel paths, and the paths you specified are not all connected to the same system.	Issue the command again and specify CIB channel paths such that all of the paths to the coupling control unit are connected to the same system.
0136	You tried to add a new or change an existing coupling control unit (message processor) for which coupling over InfiniBand (CIB) channel paths and Internal-coupling-peer (ICP) channel paths are connected.	Issue the command again and specify only CIB channel paths or only ICP channel paths as being connected to the coupling control unit and not a mixture of both.

## Adding, Deleting, or Changing an I/O Device

### Message:

HCP6806E

### Commands:

```

DEFINE DEVICE
DEFINE IODEVICE
DELETE DEVICE
DELETE IODEVICE
MODIFY DEVICE
MODIFY IODEVICE

```

Return Code	Is Issued When:	What You Can Do:
0002 0003 0004	One of the following occurred: <ol style="list-style-type: none"> <li>1. You requested a function or specified an operand that is not available in your processor.</li> <li>2. There was an internal programming error in z/VM.</li> </ol>	<ol style="list-style-type: none"> <li>1. Your z/VM system is at a more-advanced level than your processor. Use only functions and operands supported by your processor.</li> <li>2. Call IBM for service on your z/VM operating system.</li> </ol>
0008	The specified channel subsystem identifier is not a valid channel subsystem identifier in your configuration.	Issue the Query LPARS command to determine which channel subsystem images are defined in your configuration and then reissue the command with valid channel subsystem identifiers.
0103	You tried to add an I/O device, but one of the following occurred: <ol style="list-style-type: none"> <li>1. The real device number that you specified is already defined in the I/O configuration.</li> <li>2. The specified preferred channel path does not provide access to the specified I/O devices.</li> <li>3. The processor has determined that CP passed an incorrect control block while processing your DEFINE DEVICE command. This condition should never occur.</li> <li>4. You tried to add a coupling facility I/O device, but the device number that you specified is already defined for the specified coupling facility control unit.</li> </ol>	<ol style="list-style-type: none"> <li>1. Make sure that the specified devices are not already defined in the I/O configuration. That is, make sure they do not have the same unit address and device number associated with the same control unit. Then, issue the DEFINE DEVICE command again.</li> <li>2. Make sure that the control unit to which the device is defined is attached to the specified channel path. Then, issue the command again and specify the correct channel path.</li> <li>3. If this condition occurs, contact your IBM Support Center for assistance.</li> <li>4. Verify that you are defining duplicate device numbers. If you are, issue the command again and specify a different device number.</li> </ol>

## Return Codes

Return Code	Is Issued When:	What You Can Do:
0105	<p>You tried to add or change an I/O device, but one of the following occurred:</p> <ol style="list-style-type: none"> <li>1. One or more of the unit addresses that you specified is already being used by one or more of the control units to access other I/O devices.</li> <li>2. The specified I/O devices are attached to an internal control unit on shared EIO or ISD channel paths, and more than one candidate logical partition is specified.</li> <li>3. The requested configuration change would result in the definition of more I/O devices than are supported by the processor for the following channel path types: <ul style="list-style-type: none"> <li>• A fibre-channel-protocol (FCP) channel path</li> <li>• An OSA NCP (OSN) channel path specifying one or more OSN-type devices</li> <li>• An OSA NCP (OSN) channel path specifying one or more 3745-type devices</li> <li>• An OSA Direct Express (OSD, OSM, OSX) channel path.</li> </ul> </li> <li>4. The requested configuration change would result in the definition of more I/O devices on an internal-queued-direct-communication channel than are supported by the model for all internal-queued-direct-communication channels. In an LPAR environment, the sharing of I/O devices across logical partitions can affect the limit.</li> </ol>	<ol style="list-style-type: none"> <li>1. Make sure that the specified unit addresses are not already assigned to the specified control units, and reissue the command.</li> <li>2. The internal control unit in your processor for the specified I/O devices does not support access to the device by more than one logical partition. Verify and change your request to specify a single candidate logical partition.</li> <li>3. Consult the System Library publication for your processor and make the total number of I/O devices on the applicable OSA Direct Express channel does not exceed the limit for your processor.</li> <li>4. Consult the System Library publication for your processor and make the total number of I/O devices on the applicable internal-queued-direct-communication channel does not exceed the limit for your processor.</li> </ol>

Return Code	Is Issued When:	What You Can Do:
0106	<p>You tried to define a new or modify an existing I/O device, but one of the following occurred:</p> <ol style="list-style-type: none"> <li>1. You specified one or more control units that are not defined in the I/O configuration.</li> <li>2. You specified duplicate control unit numbers.</li> <li>3. The specified control units are not all of the same control unit type.</li> <li>4. The specified control units (to which the I/O devices are to be attached) do not all use the same type of channel path interfaces.</li> <li>5. The channel paths attached to the specified control units are not all of the same type.</li> <li>6. You specified two or more control units that are attached to the same channel path.</li> <li>7. On your EMIF-capable processor, some of the channel paths attached to the specified control units are not defined as: <ul style="list-style-type: none"> <li>• Shared</li> <li>• Dedicated (reconfigurable or nonreconfigurable).</li> </ul> </li> </ol>	<ol style="list-style-type: none"> <li>1. Make sure that all the specified control units are defined in the I/O configuration. If they are not, use the DEFINE CU command to define the control units, and then, issue the DEFINE DEVICE command again.</li> <li>2. Make sure that all specified control unit numbers are unique, and then issue the DEFINE DEVICE command again.</li> <li>3. Issue the DEFINE DEVICE command again and specify control units of the same type.</li> <li>4. Issue the DEFINE DEVICE command again and specify control units of the same channel path interface type.</li> <li>5. Make sure that all the channel paths (to which the control units are attached) are of the same type. If they are not, issue the DEFINE or MODIFY DEVICE command again and specify the correct channel paths.</li> <li>6. Make sure that only one of the specified control units is attached to the channel path.</li> <li>7. Make sure that the channel paths attached to the control unit are either all defined as shared or all defined as unshared (dedicated).</li> </ol>
0107	<p>You tried to add a new or modify an existing I/O device, but one or more of the following occurred:</p> <ol style="list-style-type: none"> <li>1. One or more of the specified I/O devices is attached to more control units than the channel subsystem (CSS) allows.</li> <li>2. You tried to attach one or more of the specified I/O devices to more channel paths than the channel subsystem (CSS) allows.</li> <li>3. The requested dynamic I/O change would have resulted in more than 8 channel paths being defined to an I/O device in a logical partition.</li> <li>4. The channel subsystem (CSS) does not support the requested dynamic I/O change.</li> <li>5. One or more of the specified I/O devices is attached to more control units than are allowed for that type of channel path, control unit, or device.</li> </ol>	<ol style="list-style-type: none"> <li>1. A device can only be attached to a maximum of 8 control units. Please issue the the command again and specify a maximum of 8 control units. Please note, however, that a lower limit applies to some types of devices. See the current <i>Input/Output Configuration Program User's Guide</i> for your processor for specific limits.</li> <li>2. A device can only be attached to a maximum of 8 control units and those control units can be attached to a maximum of 8 channel paths.</li> <li>3. Make sure that a maximum of 8 channel paths would result from this dynamic I/O change.</li> <li>4. Verify that the processor supports the definition or modification of I/O devices.</li> <li>5. There are special limits on the number of control units to which the specified type of device(s) can attach. Verify and change the control unit(s) and reissue the command.</li> </ol>

## Return Codes

Return Code	Is Issued When:	What You Can Do:
0108	<p>You tried to define a new or modify an existing I/O device, but one of the following occurred:</p> <ol style="list-style-type: none"> <li>1. You tried to modify one or more I/O devices by adding control unit access to the devices, but one or more of the control units were already assigned to the specified I/O device or devices.</li> <li>2. You tried to delete device access from some control units, but one or more of the control units were not assigned to the specified I/O device or devices.</li> <li>3. You tried to delete device access from one or more control units, but this would have resulted in the specified devices having no control units assigned to them.</li> <li>4. The specified preferred channel path does not provide access to the specified I/O devices.</li> <li>5. You tried to add or delete access to a logical partition on an EMIF-capable processor, but the specified I/O device (or devices) were not attached to any shared channel paths.</li> <li>6. You tried to add access to a logical partition on an EMIF-capable processor, but the specified logical partition already had access to the specified I/O device or devices.</li> <li>7. You tried to delete access to a logical partition on an EMIF-capable processor, but the specified logical partition did not have access to the specified I/O device or devices.</li> <li>8. You tried to add one or more I/O devices to an EMIF-capable processor, but you did not specify a logical partition name.</li> <li>9. On an EMIF-capable processor, you specified one or more logical partitions on a dynamic I/O command, but one or more of those logical partitions were not provided by this model of processor or they were not defined in the I/O configuration.</li> <li>10. The processor has determined that CP passed an incorrect control block while processing a MODIFY DEVICE command. This condition should never occur.</li> </ol>	<ol style="list-style-type: none"> <li>1. Insure that the control units (for which you are adding access) are not already assigned to the specified I/O device or devices. Then, issue the command again and specify the correct control unit numbers.</li> <li>2. Make sure that all of the specified control units have access to the specified I/O devices. If they do not have access, issue the command again and specify the correct control units.</li> <li>3. You cannot delete device access to the last control unit, because it would orphan the device or devices. If you want to delete the control unit, you must delete the I/O devices before deleting the control unit.</li> <li>4. You designated one channel path as the preferred channel path, but that channel path is not associated with the specified I/O devices. Issue the MODIFY DEVICE command again and specify the correct preferred channel path.</li> <li>5. Issue the command again and make sure that the channel paths providing access to the specified devices are defined as shared.</li> <li>6. Issue the command again and specify the correct logical partition name.</li> <li>7. Issue the MODIFY DEVICE command again and specify the correct logical partition name.</li> <li>8. Issue the DEFINE or MODIFY DEVICE command again and specify one or more logical partition names.</li> <li>9. Issue the QUERY LPARS command to display the logical partitions defined in your I/O configuration and verify that the logical partitions that you specified are in the displayed list. Then, issue the command again and specify the correct logical partition names.</li> <li>10. If this condition occurs, contact your IBM Support Center for assistance.</li> </ol>

Return Code	Is Issued When:	What You Can Do:
0109	<p>The processor did not have enough storage in the hardware system area (HSA) to process the dynamic I/O command that you entered.</p> <p>You tried to delete the last device on a control unit but the CSS did not have the resources to create another logical unit.</p>	<p>Issue the CP QUERY DYNAMIC_I/O Storage command to display the available resources. If the amount is not sufficient, you can make some HSA available by deleting an existing channel path that is not being used, or by increasing the amount of HSA space defined on the CONFIG screen of the support element (SE) and perform a power-on-reset (POR) of the processor.</p>
010A	<p>You tried to delete or change an existing I/O device, but the specified I/O device was not defined in the I/O configuration.</p>	<p>Issue the DELETE or MODIFY DEVICE command again and specify the correct I/O device numbers.</p>
010D	<p>You tried to add a new, or delete, or change an existing I/O device, but one or the following occurred:</p> <ol style="list-style-type: none"> <li>1. You tried to add or delete a coupling facility device, but one of the following occurred: <ol style="list-style-type: none"> <li>a. The specified control unit is not a coupling facility control unit.</li> <li>b. The specified device is defined on the wrong type of channel path.</li> <li>c. Your processor does not support the dynamic I/O configuration change that you requested.</li> <li>d. You tried to add a device with a CHPID of TYPE BYTE and you specified the NOTIME_OUT operand.</li> </ol> </li> </ol>	<ol style="list-style-type: none"> <li>1. <ol style="list-style-type: none"> <li>a. Coupling facility devices must be defined on coupling facility control units. Issue the command again, and specify a coupling facility control unit.</li> <li>b. Specify the message device as being configured to a sender channel of the appropriate type as installed on your machine.</li> <li>c. Verify the change that you are trying to make. If you believe the requested change is valid, contact your IBM Support Center for assistance.</li> <li>d. Reissue the command with the TIME_OUT operand (default).</li> </ol> </li> </ol>
010E	<p>You tried to define, delete, or modify an I/O device, but one of the following occurred:</p> <ol style="list-style-type: none"> <li>1. You specified a unit address or a unit address range for the specified I/O devices that were not defined to the specified control unit or units.</li> <li>2. You specified a range of device numbers (or unit addresses) that did not contain the same number of unit addresses (or device numbers).</li> <li>3. You tried to add or delete a coupling facility device, but the specified control unit does not provide access to one or more of the coupling facility devices.</li> </ol>	<ol style="list-style-type: none"> <li>1. Make sure that the specified unit addresses for the I/O device or devices are defined to the control unit or units. If they are not define, issue a MODIFY CU command to add the unit address or addresses, and the, issue the command again.</li> <li>2. Issue the command again and make sure the count of device numbers and unit addresses is equal. You may have to increase or decrease the number of devices on the control unit, or correct the range on the command that you issued.</li> <li>3. Verify that the specified coupling facility devices are attached to the specified control units, and the, issue the command again. If the control units appear to be correctly specified, contact your IBM Support Center for assistance.</li> </ol>

## Return Codes

Return Code	Is Issued When:	What You Can Do:
0110	You tried to define, delete, or modify an I/O device, but one of the following occurred: 1. The channel subsystem (CSS) cannot get the resources required to make the dynamic I/O configuration change. 2. The processor is temporarily unable to make the dynamic I/O configuration change that you requested.	1. The support element (SE) is being initialized or reinitialized. Wait until the SE is operational and issue the command again. 2. After waiting a short period of time for the processor to complete the internal functions that prevented this command from working the first time, issue the dynamic I/O command again.
0111	You tried to define, delete, or modify an I/O device, but the requested dynamic I/O change would result in an ambiguous or incorrect I/O configuration description.	Issue the command again and make sure that the change would not result in an usable I/O configuration.

---

## Adding, Deleting, or Changing a PCI Function

**Message:**

HCP6806E

**Commands:**

DEFINE PCIFunction  
 DELETE PCIFunction  
 MODIFY PCIFunction

Return Code	Is Issued When:	What You Can Do:
0003 0004 0007	One of the following occurred: 1. You requested a function or specified an operand that is not available in your processor. 2. There was an internal programming error in z/VM.	1. Your z/VM system is at a more-advanced level than your processor. Use only functions and operands supported by your processor. 2. Call IBM for service on your z/VM operating system.
0106	You tried to add a PCI function, but you specified one that is already defined in the I/O configuration.	Verify the PCI function that you are trying to define. If you typed it correctly, then choose a different PCI function that doesn't conflict with an existing one.

Return Code	Is Issued When:	What You Can Do:
0107	<p>One of the following occurred:</p> <ol style="list-style-type: none"> <li>1. You tried to define, or change a PCI function but one or more of the logical partitions that you specified is not currently defined in the active I/O configuration.</li> <li>2. You tried to add a PCI function or change an existing one by adding access to one or more logical partitions, and one or more logical partitions were defined in the initial access list that were not defined in the access list.</li> <li>3. You tried to change an existing PCI function by deleting one or more logical partitions from the access list, but one or more logical partitions do not have access to the PCI function.</li> <li>4. You tried to add a nonshared PCI function or change an existing nonshared PCI function by adding access to one or more logical partitions, and more than one logical partition was specified as having initial access.</li> </ol>	<ol style="list-style-type: none"> <li>1. Issue the CP QUERY LPARS command to display the list of logical partitions defined on the processor. If the logical partition is on the list, please contact your IBM support center for assistance.</li> <li>2. Reissue the command, making sure the logical partitions in the initial access list are a subset or the ones in the access list.</li> <li>3. Verify which logical partitions have access to the PCI function and issue the command again, accordingly.</li> <li>4. Issue the command again and specify only one logical partition on the initial access list.</li> </ol>
010A	You tried to change or delete an existing PCI function, but the PCI function you specified is not defined in the I/O configuration.	Verify the change you are trying to make and issue the command again.
010D	Your machine model does not support the dynamic - I/O configuration change that you requested.	Verify the change that you are trying to make. If you believe the requested change is valid, contact your IBM support center for assistance.
010F	You tried to delete a PCI function or you tried to change a PCI function by deleting one or more logical partition's access to it, and the PCI function is currently configured to one or more of those logical partitions. The system's attempt to deconfigure the PCI function from one or more logical partitions was unsuccessful.	Deconfigure the PCI function you are trying to delete from the logical partition(s) where it is configured. If you are successful, reissue the command.
0110	<p>One of the following occurred:</p> <ol style="list-style-type: none"> <li>1. The machine could not get access to certain resources required to make the requested configuration change.</li> <li>2. The processor was temporarily unable to make the requested configuration change.</li> <li>3. You issued a MODIFY PCIFUNCTION command to request conditional deletion of access by one or more logical partitions from the specified PCI function. However, the PCI function is currently configured to one or more of those logical partitions.</li> </ol>	<ol style="list-style-type: none"> <li>1. The support element (SE) might be in the process of being initialized or re-initialized. Wait until the SE is operational and reissue the command.</li> <li>2. After waiting for a period of time for the processor to complete any internal functions that might have interfered with your request, reissue the command.</li> <li>3. Deconfigure the PCI function in the affected logical partitions, thereby making the PCI function unavailable. Issue the CP MODIFY PCIFUNCTION command again to conditionally delete access from the logical partitions.</li> </ol>

## Return Codes

Return Code	Is Issued When:	What You Can Do:
0112	One of the following occurred: <ol style="list-style-type: none"> <li>1. The specified PCI function, if added to your configuration, would exceed the maximum number of PCI functions that can be configured to your machine.</li> <li>2. The value of the specified PCI function ID exceeds the maximum value supported by your machine.</li> <li>3. The value of the specified virtual function number (VFN) would exceed the maximum value supported by your machine.</li> </ol>	<ol style="list-style-type: none"> <li>1. Ensure that your desired configuration fits within the limits of your machine and reissue dynamic I/O configuration command, accordingly.</li> <li>2. Verify the ID of the PCI function that you are adding to your I/O configuration and reissue the dynamic I/O configuration command with a valid PCI function ID value for your machine.</li> <li>3. Verify the virtual function number of the PCI function that you are adding to your I/O configuration and reissue the dynamic I/O configuration command with a valid virtual function number value for your machine.</li> </ol>
011C	The specified physical channel identifier (PCHID) is not a valid PCHID in your configuration	Verify the change that you are trying to make and specify the proper physical channel identifier for the adapter you are adding.
011D	You tried to add a PCI function to your configuration, but the specified physical channel identifier (PCHID) or PCHID/Virtual Function Number (VFN) combination is already defined in your configuration.	Verify the change that you are trying to make and specify the proper physical channel identifier or PCHID/VFN combination for the PCI function you are adding.
0320	The specified network identifiers (NETID) are not the same value as those already defined for another virtual function which is defined on the same PCHID.	Check the existing NETID definitions for other virtual PCI functions using the same PCHID. Note that a null NETID must also be matched by the function being defined.
0321	A NETID value was specified for an ISM PCI function and the value was already used for another ISM PCHID.	Retry your command again and specify a different value for the NETID operation.

## Adding or Deleting a Logical Partition (LPAR)

### Message:

HCP6806E

### Commands:

DEFINE LPAR

DELETE LPAR

Return Code	Is Issued When:	What You Can Do:
0002 0003 0004	One of the following has occurred: <ol style="list-style-type: none"> <li>1. You requested a function or specified an operand that is not available in your processor.</li> <li>2. There was an internal programming error in z/VM.</li> </ol>	<ol style="list-style-type: none"> <li>1. Your z/VM system is at a more advanced level than your processor. Use only functions and operands supported by your processor.</li> <li>2. Call IBM for service on your z/VM operating system.</li> </ol>
0008	The specified channel subsystem identifier is not a valid channel subsystem identifier in your configuration.	Issue the Query LPARS command to determine which channel subsystem images are defined in your configuration and then reissue the command with valid channel subsystem identifiers.

Return Code	Is Issued When:	What You Can Do:
0100	You tried to delete an LPAR, but the logical partition name that you specified is not defined in your configuration.	Issue the Query LPARS command to determine which logical partition names are defined in your configuration and then reissue the command with a valid logical partition name.
0101	You tried to add an LPAR, but the logical partition name that you specified is already defined in your configuration.	Issue the Query LPARS command to determine which logical partition names are defined in your configuration and then reissue the command with a logical partition name that doesn't already exist in your configuration.
0103	You tried to add an LPAR, but the channel-subsystem ID (CSS) and MIF-ID combination specified on the command is either already associated with a configured logical partition or it is not associated with any reserved partition in your configuration.	Issue the Query LPARS command to determine the reserved partitions in your configuration and then reissue the command with a valid CSS/MIF-ID combination.
0106	You tried to delete an LPAR, but that logical partition still has one or more channel paths defined to it.	Issue the MODIFY CHPID command for any reconfigurable, non-managed shared, or spanned channel paths to which the LPAR to be deleted has access. Note that if the partition is the only partition with access to such a path (i.e., the partition is the only one in the access list for a channel path), a DELETE CHPID command must be issued to remove the path from the partition's configuration. Also issue the DELETE CHPID command to remove any dedicated channel paths from the logical partition's configuration. After all channel paths have been removed, reissue the command to delete the logical partition.
0107	You tried to add or delete an LPAR, but the logical partition name you specified was invalid.	Reissue the command with a valid logical partition name.  A valid logical partition name is a character string of one to eight single-byte alphanumeric characters (A-Z, upper case only, and 0-9). The first character must be alphabetic. Also, the following names are reserved and cannot be specified: <ul style="list-style-type: none"> <li>• PHYSICAL</li> <li>• REC</li> <li>• SYSTEM</li> <li>• PRIMnnnn (where each n is any decimal digit).</li> </ul>
010A	You tried to delete an LPAR, but the logical partition is an active logical partition.	You must deactivate the logical partition at the hardware console before the partition can be deleted.

## Return Codes

Return Code	Is Issued When:	What You Can Do:
0110	<p>You tried to add or delete an LPAR, but one of the following occurred:</p> <ol style="list-style-type: none"> <li>1. The machine could not get access to certain resources required to make the requested configuration change.</li> <li>2. The processor was temporarily unable to make the requested configuration change.</li> </ol>	<ol style="list-style-type: none"> <li>1. The support element (SE) might be in the process of being initialized or reinitialized. Wait until the SE is operational and reissue the command.</li> <li>2. After waiting for a period of time for the processor to complete any internal functions that might have interfered with your request, reissue the command.</li> </ol>

## Changing the Active IOCDS File

**Message:**

HCP6812E

**Commands:**

SET IOCDS\_ACTIVE

Return Code	Is Issued When:	What You Can Do:
0001-0063	There was an error in the Licensed Internal Code (LIC).	This return code appears when the Licensed Internal Code (LIC) detects an internal error. This should never happen, but if it does, contact your IBM Support Center for assistance.
0040	There was an equipment check when changing the active IOCDS file.	This can occur because of an SE error. Contact your IBM Support Center for assistance.
0066	You specified a slot ID for the IOCDS file (that you are trying to make active) that was not valid.	Issue the SET IOCDS_ACTIVE command again and specify a slot ID in the range A0 through A5 or B0 through B5.
006A	The IOCDS file (that you are trying to make active) is not valid.	Issue the SET IOCDS_ACTIVE command again and specify a valid I/O configuration. This might involve downloading a new IOCDS file using the IOCP utility.
006D	The IOCDS file (that you are trying to make active) does not have a hardware configuration token.	The active IOCDS file must contain a hardware configuration token. Use the DYN operand of the IOCP utility to add a hardware configuration token to the IOCDS file. For more information, see the description of the IOCP utility in the <i>z/VM: CP Commands and Utilities Reference</i> .
007F	The IOCDS file (that you are trying to make active) contains a hardware configuration token, but the token is not valid.	Make sure that the hardware configuration token stored in the channel subsystem (CSS) is valid. You may need to perform a power-on reset (POR) of the processor, or issue the SET CONFIGMODE ON RESET command, followed by the SET CONFIGMODE OFF command.
0080	There is no IOCDS file in the specified slot.	You specified a slot ID that does not contain an IOCDS file. Please issue the command again and specify a slot ID that does contain an IOCDS file.

Return Code	Is Issued When:	What You Can Do:
0082	The processor cannot access the IOCDS file (that you are trying to make active) because of a hardware problem.	Wait a short time and try to reaccess the IOCDS file. If it fails again, contact your IBM Support Center for assistance.
0084	While processing your SET ACTIVE_IOCDS command, another logical partition was writing an IOCDS file (that you are trying to make active) to the same slot, which prevented your command from completing successfully.	We recommend that you choose one logical partition to dynamically change the I/O configuration. It is the only way to prevent this kind of overlap of control.
0086	Your logical partition is not authorized to change the active IOCDS file.	Go to the LPSEC (Logical Partition SECurity) screen and make sure your logical partition is authorized to change the I/O configuration. For more information about becoming authorized to make dynamic I/O changes, see Chapter 19, "Migrating to Dynamic I/O Configuration," on page 291.
0087	The current I/O configuration does not contain a hardware configuration token.	For more information about creating an I/O configuration with a token, see "Preparing to Dynamically Change Your I/O Configuration" on page 292.
0088	The current hardware configuration token in the channel subsystem (CSS) does not match the hardware configuration token found in the IOCDS file (that you are trying to make active).	Please follow the Lock-Step process to prevent this condition from happening.
0089	The operational mode of the IOCDS file (that you are trying to make active) does not match the operational mode of the current IOCDS file.	You can only use the SET IOCDS_ACTIVE command to switch IOCDS files of the same operational mode. If you want to change operational modes, you must perform a power-on reset (POR) of the processor with the IOCDS file in the new operational mode.
008A	The LPAR characteristics of the IOCDS file (that you are trying to make active) and the current IOCDS file are not consistent.	This error can occur when one IOCDS file has 5 logical partitions defined and the other has 6 defined. Make sure the LPAR characteristics of the IOCDS file (that you are trying to make active) match those of the current IOCDS file.
0090	The IOCDS that you wish to make active uses functions and/or channel-path types that are not supported by your processor.	On the I/O Configuration Panel of your Service Element (SE), select the IOCDS that you wish to make active. Select the "View" action "Supported I/O mask." This will display the IOCDS-supported I/O mask and the machine-supported I/O mask. Note that the IOCDS mask must be a subset of the machine mask. A line showing "Unsupported mask items" will identify the mask bit(s) causing this error. The meaning of each bit can be found in the <i>Input/Output Configuration Program User's Guide</i> for your processor, in the section entitled "CPC Activation and Power-on Reset Error." Run the IOCP again, avoiding the use of functions and channel-path types that are not available on your processor.

## Return Codes

Return Code	Is Issued When:	What You Can Do:
0092	In the IOCDS that you wish to make active, you used a MAXDEV value that does not match the value currently in use on your processor. The MAXDEV parameter in your IOCP input defines the amount of expansion space in the hardware system area for adding additional subchannels dynamically.	On the I/O Configuration Panel of your Service Element (SE), select the IOCDS that you wish to make active. Select the "View" action "Dynamic information." The heading will be "Data set maximum number of devices" and will show the MAXDEV value defined in the selected IOCDS, along with the value currently in use on your processor. Run the IOCP again, with a MAXDEV value equal to the value currently in use on your processor – you will be able to make the resulting IOCDS active without encountering this error. If you wish to change to a MAXDEV value different from the value currently in use on your processor, you must select the IOCDS with the new value at your next power-on reset (POR), without having made it the active IOCDS.
0100	The processor has determined that CP passed an incorrect control block while processing your SET IOCDS_ACTIVE command. This condition should never occur.	If this condition occurs, contact your IBM Support Center for assistance.
01F0	CP issued: <ul style="list-style-type: none"> <li>• An SCLP command that was not valid, or</li> <li>• A valid SCLP command that was rejected by the processor because of a hardware error.</li> </ul>	Your processor may not support the SET IOCDS_ACTIVE hardware SCLP instruction. If it does, contact your IBM Support Center for assistance.
0300	The processor has determined that CP passed an incorrect control block while processing your SET IOCDS_ACTIVE command. This condition should never occur.	If this condition occurs, contact your IBM Support Center for assistance.
40F0	CP issued a valid SCLP command with a function code that was not valid.	This condition should never occur. If it does, contact your IBM Support Center for assistance.

---

## Changing the Configuration Mode Setting

**Message:**

HCP6806E

**Commands:**

SET CONFIGMODE  
SET LSYSTEM

Return Code	Is Issued When:	What You Can Do:
0102	<p>One of the following occurred:</p> <ol style="list-style-type: none"> <li>1. You issued a SET CONFIGMODE ON command, but this logical partition is already in configuration mode.</li> <li>2. You issued a SET CONFIGMODE OFF command, but this logical partition was not in configuration mode.</li> </ol>	<ol style="list-style-type: none"> <li>1. Only one user ID at a time can put the system in configuration mode. To discover which user ID has this logical partition in configuration mode, issue the QUERY CONFIGMODE command.</li> <li>2. You cannot issue the SET CONFIGMODE OFF command unless you turned configuration mode on using the SET CONFIGMODE ON command.</li> </ol>
0104	<p>You issued a SET CONFIGMODE command, but another logical partition already had the processor in configuration mode.</p>	<p>Before you can enter configuration mode, the other logical partition must exit configuration mode. Then, issue the SET DYNAMIC_I/O ON command in the same logical partition where you issued the SET CONFIGMODE command. This authorizes that logical partition to make dynamic I/O changes. Then, issue the SET CONFIGMODE ON command and make the changes.</p> <p><b>Note:</b> We <b>strongly</b> recommend that you allow only one logical partition read/write access to the IOCDS file, and dynamically change the I/O configuration. If you have not yet followed this recommendation, please read Chapter 21, "Understanding Dynamic I/O Configuration and LPARs," on page 307.</p>

## Return Codes

Return Code	Is Issued When:	What You Can Do:
0106	<p>You issued the SET CONFIGMODE ON command and the system was not in configuration mode, but one of the following occurred:</p> <ol style="list-style-type: none"> <li>1. There was no hardware configuration token in the channel subsystem (CSS).</li> <li>2. The compare portion of the current VM configuration token and the hardware configuration token in the channel subsystem (CSS) do not match.</li> <li>3. The valid bit in the VM configuration token and the hardware configuration token in the channel subsystem (CSS) do not match.</li> </ol>	<ol style="list-style-type: none"> <li>1. Before you can turn configuration mode on, your processor must support, and enable, dynamic I/O configuration changes. Please see Chapter 19, "Migrating to Dynamic I/O Configuration," on page 291 through Chapter 22, "Using VM Dynamic I/O Configuration," on page 313 for more information on migrating to and using the dynamic I/O configuration support.</li> <li>2. Issue the SET DYNAMIC_I/O OFF command, followed by the SET DYNAMIC_I/O ON command, to reset the tokens. <b>Note:</b> This situation can occur when another logical partition changes the I/O configuration dynamically. We <b>strongly</b> recommend that you only allow one logical partition to dynamically change the I/O configuration.</li> <li>3. This condition can occur when a user enters configuration mode and logs off or is forced off the system. When you enter configuration mode, CP sets the Invalid Configuration Bit on in the hardware. When you exit configuration mode, CP sets the bit off. In this case, the user logged off or was forced off before the bit could be turned off. No new dynamic I/O changes can occur while the bit is on. To reset the Invalid Configuration Bit, issue the SET CONFIGMODE ON RESET command, immediately followed by the SET CONFIGMODE OFF command.</li> </ol>
0107	Your dynamic I/O command cannot be processed because an authorized user turned off the dynamic I/O capability on the CONFIG screen.	Go to the hardware CONFIG screen, enable the dynamic I/O support, and issue your dynamic I/O command again.
0108	The service console operator suspended the capability to make dynamic I/O changes to the I/O configuration.	Perform a power-on reset (POR) of the processor. If that does not correct the problem, contact your IBM Support Center for assistance.

## Displaying All Channel Paths and Their Physical Status

**Message:**

HCP6813E

**Commands:**

QUERY CHPIDS

Return Code	Is Issued When:	What You Can Do:
0040	An equipment check occurred while processing the QUERY CHPIDS command.	This condition can occur because of a support element (SE) error. Contact your IBM Support Center for assistance.

Return Code	Is Issued When:	What You Can Do:
0100	The processor has determined that CP passed an incorrect control block during processing of the QUERY CHPIDS command. This condition should never occur.	If this condition occurs, contact your IBM Support Center for assistance.
01F0	CP issued: 1. An SCLP command that was not valid (that is, one that your processor does not support). 2. A valid SCLP command, but the processor rejected the command because of an error in the Licensed Internal Code (LIC).	1. Contact your IBM Support Center for assistance in determining whether your processor supports this SCLP command. 2. Contact your IBM Support Center for assistance.
0300	The processor has determined that CP passed an incorrect control block while processing a QUERY CHPIDS command. This condition should never occur.	If this condition occurs, contact your IBM Support Center for assistance.

---

## Displaying HSA Starting and Ending Addresses and Available HSA Space

**Message:**

HCP6849E

**Commands:**

QUERY HSA

Return Code	Is Issued When:	What You Can Do:
0040	An equipment check occurred while processing the QUERY HSA command.	This condition can occur because of a support element (SE) error. Contact your IBM Support Center for assistance.
0100	The processor has determined that CP passed an incorrect control block while processing the QUERY HSA command. This condition should never occur.	If this condition occurs, contact your IBM Support Center for assistance.
02F0	The processor has determined that CP passed an incorrect control block while processing the QUERY HSA command. This condition should never occur.	If this condition occurs, contact your IBM Support Center for assistance.
0300	The processor has determined that CP passed an incorrect control block while processing the QUERY HSA command. This condition should never occur.	If this condition occurs, contact your IBM Support Center for assistance.

---

## Vary a Channel Path Offline

**Message:**

HCP6811E

**Commands:**

VARY OFFLINE CHPID

## Return Codes

Return Code	Is Issued When:	What You Can Do:
0040	An equipment check occurred while processing the VARY OFFLINE CHPID command.	This condition can occur because of a support element (SE) error. Contact your IBM Support Center for assistance.
0100	The processor has determined that CP passed an incorrect control block while processing a VARY OFFLINE CHPID command. This condition should never occur.	If this condition occurs, contact your IBM Support Center for assistance.
0120	The specified channel path is not defined in the active I/O configuration.	Issue the VARY OFFLINE CHPID command again, and specify a valid, defined channel path.
01F0	CP issued: <ol style="list-style-type: none"> <li>1. An SCLP command that was not valid (that is, one that your processor does not support).</li> <li>2. A valid SCLP command, but the processor rejected the command because of an error in the Licensed Internal Code (LIC).</li> </ol>	<ol style="list-style-type: none"> <li>1. Contact your IBM Support Center for assistance in determining whether your processor supports this SCLP command.</li> <li>2. Contact your IBM Support Center for assistance.</li> </ol>
0240	The VARY OFFLINE CHPID command did not complete successfully and the processor left the channel path in an unknown state.	Issue the QUERY CHPIDS, QUERY PATH, and QUERY CHPID commands to display the current status of the channel path. If the displayed information is inconclusive, check the channel configuration frame for more information. If you cannot determine the state of the channel path, contact your IBM Support Center for assistance.
0250	There was a configuration check associated with the channel path and the processor left the channel path in an unknown state.	Issue the QUERY CHPIDS, QUERY PATH, and QUERY CHPID commands to display the current status of the channel path. If the displayed information is inconclusive, check the channel configuration frame for more information. If you cannot determine the state of the channel path, contact your IBM Support Center for assistance.
0300	The processor has determined that CP passed an incorrect control block while processing a VARY OFFLINE CHPID command. This condition should never occur.	If this condition occurs, contact your IBM Support Center for assistance.
03F0	The SCLP did not recognize the channel path ID that was passed on the VARY OFFLINE CHPID command.	Check the specified channel path ID. Issue the command again, and specify the correct channel path ID.
0440	While processing the VARY OFFLINE CHPID command, there was a hardware failure associated with the channel path and the processor changed the state of the channel path.	Check the state of the channel path using the QUERY CHPIDS command or the hardware channel configuration frame. If the problem persists, contact your IBM Support Center for assistance.
0450	While processing the VARY OFFLINE CHPID command, there was a configuration check associated with the channel path and the processor changed the state of the channel path.	Check the state of the channel path using the QUERY CHPIDS command or the hardware channel configuration frame. If the problem persists, contact your IBM Support Center for assistance.

Return Code	Is Issued When:	What You Can Do:
0540	While processing the VARY OFFLINE CHPID command, there was a hardware failure associated with the channel path, but the processor did not change the state of the channel path.	Check the state of the channel path using the QUERY CHPIDS command or the hardware channel configuration frame. If the problem persists, contact your IBM Support Center for assistance.
0550	While processing the VARY OFFLINE CHPID command, there was a configuration check associated with the channel path, but the processor did not change the state of the channel path.	Check the state of the channel path using the QUERY CHPIDS command or the hardware channel configuration frame. If the problem persists, contact your IBM Support Center for assistance.
05F0	The VARY ONLINE CHPID command failed because the specified channel path is in a channel subsystem (CSS) reserved state or it is not installed in the CSS.	If someone is servicing the channel path, the reserved state could be single channel service (SCS) mode. If so, wait until the servicing is complete and issue the command again. If not, contact your IBM Support Center for assistance.
0AF0	You tried to vary a channel path offline, but it was the only online channel path in the requested I/O configuration.	You cannot take the last channel path offline to the I/O configuration.

## Vary a Channel Path Online

**Message:**

HCP6811E

**Commands:**

VARY ONLINE CHPID

Return Code	Is Issued When:	What You Can Do:
0040	An equipment check occurred while processing the VARY ONLINE CHPID command.	This condition can occur because of a support element (SE) error. Contact your IBM Support Center for assistance.
0100	The processor has determined that CP passed an incorrect control block while processing a VARY ONLINE CHPID command. This condition should never occur.	If this condition occurs, contact your IBM Support Center for assistance.
0120	The specified channel path is already defined and online in the active I/O configuration.	Issue the VARY ONLINE CHPID command again, and specify the correct channel path ID.
01F0	CP issued: <ol style="list-style-type: none"> <li>1. An SCLP command that was not valid (that is, one that your processor does not support).</li> <li>2. A valid SCLP command, but the processor rejected the command because of an error in the Licensed Internal Code (LIC).</li> </ol>	<ol style="list-style-type: none"> <li>1. Contact your IBM Support Center for assistance in determining whether your processor supports this SCLP command.</li> <li>2. Contact your IBM Support Center for assistance.</li> </ol>

## Return Codes

Return Code	Is Issued When:	What You Can Do:
0250	There was a configuration check associated with the channel path and the processor left the channel path in an unknown state.	Issue the QUERY CHPIDS, QUERY PATH, and QUERY CHPID commands to display the current status of the channel path. If the displayed information is inconclusive, check the channel configuration frame for more information. If you cannot determine the state of the channel path, contact your IBM Support Center for assistance.
0300	The processor has determined that CP passed an incorrect control block while processing a VARY ONLINE CHPID command. This condition should never occur.	If this condition occurs, contact your IBM Support Center for assistance.
03F0	The SCLP did not recognize the channel path ID that was specified on the VARY ONLINE CHPID command.	Verify the specified channel path ID. Issue the command again, and specify the correct channel path ID.
0440	While processing the VARY ONLINE CHPID command, there was a hardware failure associated with the channel path and the processor changed the state of the channel path.	Check the state of the channel path using the QUERY CHPIDS command or the hardware channel configuration frame. If the problem persists, contact your IBM Support Center for assistance.
0450	While processing the VARY ONLINE CHPID command, there was a configuration check associated with the channel path and the processor changed the state of the channel path.	Check the state of the channel path using the QUERY CHPIDS command or the hardware channel configuration frame. If the problem persists, contact your IBM Support Center for assistance.
0540	While processing the VARY ONLINE CHPID command, there was a hardware failure associated with the channel path, but the processor did not change the state of the channel path.	Check the state of the channel path using the QUERY CHPIDS command or the hardware channel configuration frame. If the problem persists, contact your IBM Support Center for assistance.
0550	While processing the VARY ONLINE CHPID command, there was a configuration check associated with the channel path, but the processor did not change the state of the channel path.	Check the state of the channel path using the QUERY CHPIDS command or the hardware channel configuration frame. If the problem persists, contact your IBM Support Center for assistance.
05F0	The VARY ONLINE CHPID command failed because the specified channel path is in a channel subsystem (CSS) reserved state.	If someone is servicing the channel path, the reserved state could be single channel service (SCS) mode. If so, wait until the servicing is complete and issue the command again. If not, contact your IBM Support Center for assistance.
10F0	The channel path ID specified is powered off and in standby state.	Verify that the channel path is powered off. If it is not powered off, contact your IBM Support Center for assistance.

---

## Part 4. Appendixes



---

## Appendix. Using UIMs with z/VM HCD

Unit information modules (UIMs) contain the information and rules that HCD uses to process I/O device definitions. When you update an IODF, HCD uses UIMs to validate the device definitions you enter. UIMs are provided with HCD for devices that z/VM supports.

To include your own UIM in a z/VM environment, first see "Appendix A. Sample of a Unit Information Module (UIM)" in *z/OS MVS Device Validation Support*. You can use this sample as a model for writing your own UIM. You'll see as part of those directions that a corresponding UDT must be developed for each new UIM.

For a new UIM named (for example) CBDUC312 and its associated UDT named CBDEC312, the following steps need to be done to include it in HCD:

1. Develop the assembler source of the UIM and its UDT, which will result in the following files:

```
CBDUC312 ASSEMBLE
CBDEC312 ASSEMBLE
```

2. Assemble the source files using the following CMS commands:

```
GLOBAL MACLIB CBDMAC
FILEDEF SYSLIB DISK CBDMAC MACLIB *
ASMAHL CBDUC312
ASMAHL CBDEC312
```

The following two text files will be created upon assembly:

```
CBDUC312 TEXT
CBDEC312 TEXT
```

If you are using the Direct Link procedure (as described below), then the text files should be placed on the local/sample disk (default 5VMHCD20 2C2 disk).

3. At this point, you need to choose one of the following two link procedures:
  - **Direct Link:** If you wish to directly link the UIM and UDT into CDBMOD LOADLIB, you need to follow the VMSES/E local modification procedure for replacement-maintained parts. You will create a local modification for the build list CBDBLLLB EXEC.

Follow these steps to put a local modification onto the CDBMOD LOADLIB.

**Note:** Where you see *compname*, substitute **VMHCD** if you are using minidisks or **VMHCDSFS** if you are using SFS directories

- a. Log on to the HCD/HCM installation user ID, **5VMHCD20** (the default)
- b. Access the HCD/HCM disks or directories:

```
VMFSETUP 5VMHCD20 compname
```

- c. Copy the highest level of the build list to the local disk/directory:

```
VMFREPL CBDBLLLB EXEC 5VMHCD20 compname
($SELECT LOGMOD L0001 OUTMODE LOCAL
```

- d. XEDIT the build list on the local disk/directory:

```
XEDIT CBDBLLLB EXCL0001 E
```

- e. Update the build list by adding the following four lines for each TEXT file you have:

```
:OBJNAME. filename
:OPTIONS. NOGETLVL
:PARTID. filename TEXT
:EOBJNAME.
```

where *filename* is file name of your TEXT file (for example, **CBDUC312** TEXT).

After you complete your updates, type **file** on the command line.

f. Rebuild the CBDMOD LOADLIB:

```
VMFBLD PPF 5VMHCD20 compname (SERVICED
```

g. Copy the new CBDMOD LOADLIB into production (from the 300 disk to the 400 disk or equivalent directories):

– If using minidisk:

```
access 400 z
vmfcopy cbdmod * i = = z (prodid 5vmhcd20%vmhcd olddate replace
```

– If using SFS directories:

```
access vmsys:5vmhcd20.vmhcd.buildprd z
vmfcopy cbdmod * i = = z (prodid 5vmhcd20%vmhcd olddate replace
```

h. Re-IPL and then reactivate the HCD/HCM for z/VM TCP/IP dispatcher service virtual machine (default user ID **CBDIODSP**).

For more information on the VM/SES commands, see the *z/VM: VMSES/E Introduction and Reference*.

- **Indirect Link:** Alternately, you may choose to link the two text files into a separate LOADLIB (for example CBDMOD2) to be concatenated before CBDMOD. Then, the link steps would be as follows:

```
LKED CBDUC312 (LIBE CBDMOD2
LKED CBDEC312 (LIBE CBDMOD2
```

In this case, you would also need to change the GLOBAL statement in the PROFILE EXEC and in the HCD REXX utilities from:

```
GLOBAL LOADLIB CBDMOD
```

to:

```
GLOBAL LOADLIB CBDMOD2 CBDMOD
```

Finally, you would also need to change the FILEDEF statements in CBDS DISP and in the other HCD REXX utilities from:

```
Address CMS 'FILEDEF HCDLOAD DISK CBDMOD LOADLIB * (PERM'
```

to:

```
Address CMS 'FILEDEF HCDLOAD DISK CBDMOD2 LOADLIB * (PERM CONCAT'
Address CMS 'FILEDEF HCDLOAD DISK CBDMOD LOADLIB * (PERM CONCAT'
```

For more information on the LKED, GLOBAL, and FILEDEF commands, see the *z/VM: CMS Commands and Utilities Reference*.

---

## Notices

This information was developed for products and services offered in the US. This material might be available from IBM in other languages. However, you may be required to own a copy of the product or product version in that language in order to access it.

IBM may not offer the products, services, or features discussed in this document in other countries. Consult your local IBM representative for information on the products and services currently available in your area. Any reference to an IBM product, program, or service is not intended to state or imply that only that IBM product, program, or service may be used. Any functionally equivalent product, program, or service that does not infringe any IBM intellectual property right may be used instead. However, it is the user's responsibility to evaluate and verify the operation of any non-IBM product, program, or service.

IBM may have patents or pending patent applications covering subject matter described in this document. The furnishing of this document does not grant you any license to these patents. You can send license inquiries, in writing, to:

*IBM Director of Licensing  
IBM Corporation  
North Castle Drive, MD-NC119  
Armonk, NY 10504-1785  
US*

For license inquiries regarding double-byte character set (DBCS) information, contact the IBM Intellectual Property Department in your country or send inquiries, in writing, to:

*Intellectual Property Licensing  
Legal and Intellectual Property Law  
IBM Japan Ltd.  
19-21, Nihonbashi-Hakozakicho, Chuo-ku  
Tokyo 103-8510, Japan*

INTERNATIONAL BUSINESS MACHINES CORPORATION PROVIDES THIS PUBLICATION "AS IS" WITHOUT WARRANTY OF ANY KIND, EITHER EXPRESS OR IMPLIED, INCLUDING, BUT NOT LIMITED TO, THE IMPLIED WARRANTIES OF NON-INFRINGEMENT, MERCHANTABILITY OR FITNESS FOR A PARTICULAR PURPOSE. Some jurisdictions do not allow disclaimer of express or implied warranties in certain transactions, therefore, this statement may not apply to you.

This information could include technical inaccuracies or typographical errors. Changes are periodically made to the information herein; these changes will be incorporated in new editions of the publication. IBM may make improvements and/or changes in the product(s) and/or the program(s) described in this publication at any time without notice.

Any references in this information to non-IBM websites are provided for convenience only and do not in any manner serve as an endorsement of those

websites. The materials at those websites are not part of the materials for this IBM product and use of those websites is at your own risk.

IBM may use or distribute any of the information you provide in any way it believes appropriate without incurring any obligation to you.

Licensees of this program who wish to have information about it for the purpose of enabling: (i) the exchange of information between independently created programs and other programs (including this one) and (ii) the mutual use of the information which has been exchanged, should contact:

*IBM Director of Licensing  
IBM Corporation  
North Castle Drive, MD-NC119  
Armonk, NY 10504-1785  
US*

Such information may be available, subject to appropriate terms and conditions, including in some cases, payment of a fee.

The licensed program described in this document and all licensed material available for it are provided by IBM under terms of the IBM Customer Agreement, IBM International Program License Agreement or any equivalent agreement between us.

The performance data and client examples cited are presented for illustrative purposes only. Actual performance results may vary depending on specific configurations and operating conditions.

Information concerning non-IBM products was obtained from the suppliers of those products, their published announcements or other publicly available sources. IBM has not tested those products and cannot confirm the accuracy of performance, compatibility or any other claims related to non-IBM products. Questions on the capabilities of non-IBM products should be addressed to the suppliers of those products.

Statements regarding IBM's future direction or intent are subject to change or withdrawal without notice, and represent goals and objectives only.

This information may contain examples of data and reports used in daily business operations. To illustrate them as completely as possible, the examples include the names of individuals, companies, brands, and products. All of these names are fictitious and any similarity to actual people or business enterprises is entirely coincidental.

#### COPYRIGHT LICENSE:

This information may contain sample application programs in source language, which illustrate programming techniques on various operating platforms. You may copy, modify, and distribute these sample programs in any form without payment to IBM, for the purposes of developing, using, marketing or distributing application programs conforming to the application programming interface for the operating platform for which the sample programs are written. These examples have not been thoroughly tested under all conditions. IBM, therefore, cannot guarantee or imply reliability, serviceability, or function of these programs. The

sample programs are provided “AS IS”, without warranty of any kind. IBM shall not be liable for any damages arising out of your use of the sample programs.

---

## Programming Interface Information

This book primarily documents information that is NOT intended to be used as Programming Interfaces of z/VM.

This book also documents intended Programming Interfaces that allow the customer to write programs to obtain the services of z/VM. This information is identified where it occurs, either by an introductory statement to a chapter or section or by the following marking:

**PI**

<...Programming Interface information...>

**PI end**

---

## Trademarks

IBM, the IBM logo, and [ibm.com](http://ibm.com)<sup>®</sup> are trademarks or registered trademarks of International Business Machines Corp., registered in many jurisdictions worldwide. Other product and service names might be trademarks of IBM or other companies. A current list of IBM trademarks is available on the web at IBM copyright and trademark information - United States ([www.ibm.com/legal/us/en/copytrade.shtml](http://www.ibm.com/legal/us/en/copytrade.shtml)).

InfiniBand is a trademark and/or service mark of the InfiniBand Trade Association.

Linux is a registered trademark of Linus Torvalds in the United States, other countries, or both.

Other company, product, and service names may be trademarks or service marks of others.

---

## Terms and Conditions for Product Documentation

Permissions for the use of these publications are granted subject to the following terms and conditions.

### Applicability

These terms and conditions are in addition to any terms of use for the IBM website.

### Personal Use

You may reproduce these publications for your personal, noncommercial use provided that all proprietary notices are preserved. You may not distribute, display or make derivative work of these publications, or any portion thereof, without the express consent of IBM.

## Commercial Use

You may reproduce, distribute and display these publications solely within your enterprise provided that all proprietary notices are preserved. You may not make derivative works of these publications, or reproduce, distribute or display these publications or any portion thereof outside your enterprise, without the express consent of IBM.

## Rights

Except as expressly granted in this permission, no other permissions, licenses or rights are granted, either express or implied, to the publications or any information, data, software or other intellectual property contained therein.

IBM reserves the right to withdraw the permissions granted herein whenever, in its discretion, the use of the publications is detrimental to its interest or, as determined by IBM, the above instructions are not being properly followed.

You may not download, export or re-export this information except in full compliance with all applicable laws and regulations, including all United States export laws and regulations.

IBM MAKES NO GUARANTEE ABOUT THE CONTENT OF THESE PUBLICATIONS. THE PUBLICATIONS ARE PROVIDED "AS-IS" AND WITHOUT WARRANTY OF ANY KIND, EITHER EXPRESSED OR IMPLIED, INCLUDING BUT NOT LIMITED TO IMPLIED WARRANTIES OF MERCHANTABILITY, NON-INFRINGEMENT, AND FITNESS FOR A PARTICULAR PURPOSE.

---

## IBM Online Privacy Statement

IBM Software products, including software as a service solutions, ("Software Offerings") may use cookies or other technologies to collect product usage information, to help improve the end user experience, to tailor interactions with the end user, or for other purposes. In many cases no personally identifiable information is collected by the Software Offerings. Some of our Software Offerings can help enable you to collect personally identifiable information. If this Software Offering uses cookies to collect personally identifiable information, specific information about this offering's use of cookies is set forth below.

This Software Offering does not use cookies or other technologies to collect personally identifiable information.

If the configurations deployed for this Software Offering provide you as customer the ability to collect personally identifiable information from end users via cookies and other technologies, you should seek your own legal advice about any laws applicable to such data collection, including any requirements for notice and consent.

For more information about the use of various technologies, including cookies, for these purposes, see IBM Online Privacy Statement Highlights at <http://www.ibm.com/privacy> and the IBM Online Privacy Statement at <http://www.ibm.com/privacy/details> in the section entitled "Cookies, Web Beacons and Other Technologies", and the IBM Software Products and Software-as-a-Service Privacy Statement at <http://www.ibm.com/software/info/product-privacy>.

---

## Glossary

For a list of z/VM terms and their definitions, see *z/VM: Glossary*.

The z/VM glossary is also available through the online z/VM HELP Facility, if HELP files are installed on your z/VM system. For example, to display the definition of the term “dedicated device”, issue the following HELP command:  
`help glossary dedicated device`

While you are in the glossary help file, you can do additional searches:

- To display the definition of a new term, type a new HELP command on the command line:

```
help glossary newterm
```

This command opens a new help file inside the previous help file. You can repeat this process many times. The status area in the lower right corner of the screen shows how many help files you have open. To close the current file, press the Quit key (PF3/F3). To exit from the HELP Facility, press the Return key (PF4/F4).

- To search for a word, phrase, or character string, type it on the command line and press the Clocate key (PF5/F5). To find other occurrences, press the key multiple times.

The Clocate function searches from the current location to the end of the file. It does not wrap. To search the whole file, press the Top key (PF2/F2) to go to the top of the file before using Clocate.



---

## Bibliography

See the following publications for additional information about z/VM. For abstracts of the z/VM publications, see *z/VM: General Information*, GC24-6193.

---

### Where to Get z/VM Information

z/VM product information is available from the following sources:

- IBM Knowledge Center z/VM welcome page ([www.ibm.com/support/knowledgecenter/SSB27U/welcome](http://www.ibm.com/support/knowledgecenter/SSB27U/welcome))
- IBM Publications Center ([www.ibm.com/e-business/linkweb/publications/servlet/pbi.wss](http://www.ibm.com/e-business/linkweb/publications/servlet/pbi.wss))
- *IBM Online Library: z/VM Collection*, SK5T-7054
- IBM: z/VM Internet Library ([www.ibm.com/vm/library/](http://www.ibm.com/vm/library/))

---

### z/VM Base Library

#### Overview

- *z/VM: General Information*, GC24-6193
- *z/VM: Glossary*, GC24-6195
- *z/VM: License Information*, GC24-6200

#### Installation, Migration, and Service

- *z/VM: Installation Guide*, GC24-6246
- *z/VM: Migration Guide*, GC24-6201
- *z/VM: Service Guide*, GC24-6247
- *z/VM: VMSES/E Introduction and Reference*, GC24-6243

#### Planning and Administration

- *z/VM: CMS File Pool Planning, Administration, and Operation*, SC24-6167
- *z/VM: CMS Planning and Administration*, SC24-6171
- *z/VM: Connectivity*, SC24-6174
- *z/VM: CP Planning and Administration*, SC24-6178
- *z/VM: Enabling z/VM for OpenStack (Support for OpenStack Icehouse Release)*, SC24-6248
- *z/VM: Enabling z/VM for OpenStack (Support for OpenStack Juno Release)*, SC24-6249

- *z/VM: Enabling z/VM for OpenStack (Support for OpenStack Kilo Release)*, SC24-6250
- *z/VM: Enabling z/VM for OpenStack (Support for OpenStack Liberty Release)*, SC24-6251
- *z/VM: Getting Started with Linux on System z*, SC24-6194
- *z/VM: Group Control System*, SC24-6196
- *z/VM: I/O Configuration*, SC24-6198
- *z/VM: Running Guest Operating Systems*, SC24-6228
- *z/VM: Saved Segments Planning and Administration*, SC24-6229
- *z/VM: Secure Configuration Guide*, SC24-6230
- *z/VM: TCP/IP LDAP Administration Guide*, SC24-6236
- *z/VM: TCP/IP Planning and Customization*, SC24-6238
- *z/OS and z/VM: Hardware Configuration Manager User's Guide*, SC33-7989

#### Customization and Tuning

- *z/VM: CP Exit Customization*, SC24-6176
- *z/VM: Performance*, SC24-6208

#### Operation and Use

- *z/VM: CMS Commands and Utilities Reference*, SC24-6166
- *z/VM: CMS Pipelines Reference*, SC24-6169
- *z/VM: CMS Pipelines User's Guide*, SC24-6170
- *z/VM: CMS Primer*, SC24-6172
- *z/VM: CMS User's Guide*, SC24-6173
- *z/VM: CP Commands and Utilities Reference*, SC24-6175
- *z/VM: System Operation*, SC24-6233
- *z/VM: TCP/IP User's Guide*, SC24-6240
- *z/VM: Virtual Machine Operation*, SC24-6241
- *z/VM: XEDIT Commands and Macros Reference*, SC24-6244
- *z/VM: XEDIT User's Guide*, SC24-6245

#### Application Programming

- *z/VM: CMS Application Development Guide*, SC24-6162
- *z/VM: CMS Application Development Guide for Assembler*, SC24-6163

- *z/VM: CMS Application Multitasking*, SC24-6164
- *z/VM: CMS Callable Services Reference*, SC24-6165
- *z/VM: CMS Macros and Functions Reference*, SC24-6168
- *z/VM: CP Programming Services*, SC24-6179
- *z/VM: CPI Communications User's Guide*, SC24-6180
- *z/VM: Enterprise Systems Architecture/Extended Configuration Principles of Operation*, SC24-6192
- *z/VM: Language Environment User's Guide*, SC24-6199
- *z/VM: OpenExtensions Advanced Application Programming Tools*, SC24-6202
- *z/VM: OpenExtensions Callable Services Reference*, SC24-6203
- *z/VM: OpenExtensions Commands Reference*, SC24-6204
- *z/VM: OpenExtensions POSIX Conformance Document*, GC24-6205
- *z/VM: OpenExtensions User's Guide*, SC24-6206
- *z/VM: Program Management Binder for CMS*, SC24-6211
- *z/VM: Reusable Server Kernel Programmer's Guide and Reference*, SC24-6220
- *z/VM: REXX/VM Reference*, SC24-6221
- *z/VM: REXX/VM User's Guide*, SC24-6222
- *z/VM: Systems Management Application Programming*, SC24-6234
- *z/VM: TCP/IP Programmer's Reference*, SC24-6239
- *Common Programming Interface Communications Reference*, SC26-4399
- *Common Programming Interface Resource Recovery Reference*, SC31-6821
- *z/OS: IBM Tivoli Directory Server Plug-in Reference for z/OS*, SA76-0148
- *z/OS: Language Environment Concepts Guide*, SA22-7567
- *z/OS: Language Environment Debugging Guide*, GA22-7560
- *z/OS: Language Environment Programming Guide*, SA22-7561
- *z/OS: Language Environment Programming Reference*, SA22-7562
- *z/OS: Language Environment Run-Time Messages*, SA22-7566
- *z/OS: Language Environment Writing Interlanguage Communication Applications*, SA22-7563

- *z/OS MVS Program Management: Advanced Facilities*, SA22-7644
- *z/OS MVS Program Management: User's Guide and Reference*, SA22-7643

## Diagnosis

- *z/VM: CMS and REXX/VM Messages and Codes*, GC24-6161
- *z/VM: CP Messages and Codes*, GC24-6177
- *z/VM: Diagnosis Guide*, GC24-6187
- *z/VM: Dump Viewing Facility*, GC24-6191
- *z/VM: Other Components Messages and Codes*, GC24-6207
- *z/VM: TCP/IP Diagnosis Guide*, GC24-6235
- *z/VM: TCP/IP Messages and Codes*, GC24-6237
- *z/VM: VM Dump Tool*, GC24-6242
- *z/OS and z/VM: Hardware Configuration Definition Messages*, SC33-7986

---

## z/VM Facilities and Features

### Data Facility Storage Management Subsystem for VM

- *z/VM: DFSMS/VM Customization*, SC24-6181
- *z/VM: DFSMS/VM Diagnosis Guide*, GC24-6182
- *z/VM: DFSMS/VM Messages and Codes*, GC24-6183
- *z/VM: DFSMS/VM Planning Guide*, SC24-6184
- *z/VM: DFSMS/VM Removable Media Services*, SC24-6185
- *z/VM: DFSMS/VM Storage Administration*, SC24-6186

### Directory Maintenance Facility for z/VM

- *z/VM: Directory Maintenance Facility Commands Reference*, SC24-6188
- *z/VM: Directory Maintenance Facility Messages*, GC24-6189
- *z/VM: Directory Maintenance Facility Tailoring and Administration Guide*, SC24-6190

### Open Systems Adapter/Support Facility

- *z Systems: Open Systems Adapter-Express Customer's Guide and Reference*, SA22-7935
- *System z9 and eServer zSeries 890 and 990: Open Systems Adapter-Express Integrated Console Controller User's Guide*, SA22-7990
- *System z: Open Systems Adapter-Express Integrated Console Controller 3215 Support*, SA23-2247

- *System z10: Open Systems Adapter-Express3 Integrated Console Controller Dual-Port User's Guide*, SA23-2266

### **Performance Toolkit for VM**

- *z/VM: Performance Toolkit Guide*, SC24-6209
- *z/VM: Performance Toolkit Reference*, SC24-6210

### **RACF® Security Server for z/VM**

- *z/VM: RACF Security Server Auditor's Guide*, SC24-6212
- *z/VM: RACF Security Server Command Language Reference*, SC24-6213
- *z/VM: RACF Security Server Diagnosis Guide*, GC24-6214
- *z/VM: RACF Security Server General User's Guide*, SC24-6215
- *z/VM: RACF Security Server Macros and Interfaces*, SC24-6216
- *z/VM: RACF Security Server Messages and Codes*, GC24-6217
- *z/VM: RACF Security Server Security Administrator's Guide*, SC24-6218
- *z/VM: RACF Security Server System Programmer's Guide*, SC24-6219
- *z/VM: Security Server RACROUTE Macro Reference*, SC24-6231

### **Remote Spooling Communications Subsystem Networking for z/VM**

- *z/VM: RSCS Networking Diagnosis*, GC24-6223
- *z/VM: RSCS Networking Exit Customization*, SC24-6224
- *z/VM: RSCS Networking Messages and Codes*, GC24-6225
- *z/VM: RSCS Networking Operation and Use*, SC24-6226
- *z/VM: RSCS Networking Planning and Configuration*, SC24-6227

---

## **Prerequisite Products**

### **Device Support Facilities**

- *Device Support Facilities: User's Guide and Reference*, GC35-0033

### **Environmental Record Editing and Printing Program**

- *Environmental Record Editing and Printing Program (EREP): Reference*, GC35-0152

- *Environmental Record Editing and Printing Program (EREP): User's Guide*, GC35-0151

---

## **Additional Publications**

*z/OS MVS Device Validation Support*, SA22-7586



---

## Index

### Special characters

\*\$HCD\$ 47  
\*\$HCDC\$ 47

### Numerics

2064 processor  
  enabling dynamic I/O configuration for 293  
3380 DASD  
  replacing with RAMAC DASDs 321  
3390 DASD  
  adding to 3990 controller 304, 317  
3490 tape drive  
  sharing between logical partitions 319  
3990 controller  
  adding 3390 DASD to 304, 317

### A

abnormal termination 238  
actions on objects, migration enhancements 107  
activate an IODF, target IODF 163  
activate new configuration  
  dynamic configuration 55  
  HCD panel 55  
  testing 64  
active  
  IOCDS file  
    adding configuration token to 293  
    bringing online 283  
    creating 278  
    directing flow of I/O data 278  
    generating 293  
    writing to SE hard disk 293  
activity log 37  
  naming convention 31  
activity logging  
  automatic 29  
  HCD profile 29  
  rules 37  
adapter  
  open systems  
    receiving unpredictable results on 329  
    sharing on EMIF-capable processors in LPAR  
      mode 281  
    sharing on LCSS-capable processors in LPAR  
      mode 281  
add  
  additional  
    SCMBK space 295, 308  
  channel path 286, 317  
  configuration token to IOCDS file 293  
  control unit 317, 342  
  logical partition 286  
  real devices  
    3390 DASDs to 3990 controller 304, 317  
    SCMBK space 295, 308  
advantages of extended migration 87

allocate  
  storage  
    for SCMBKs 295, 308  
alternate DD names 173  
assembler check, migration 115  
assembler statements 81  
assembly listing 115

### B

back up  
  system configuration file 294  
backup IODF  
  naming convention 31  
block, subchannel measurement  
  adding more storage space for 295, 308  
BookMaster 71  
browse activity log 73  
build  
  production IODF, batch 133  
  work IODF, batch 135  
build configuration statements 87  
build production IODF 35  
build work IODF from production IODF 36

### C

cascade switching 41  
CBDCONF NAMES 121  
CBDMCONF 170  
  return codes 170  
CBDSACT 36, 166  
CBDSCOMP 36, 155, 156  
CBDSCONF 87, 88, 141  
CBDSCOPY 35, 143  
CBSDPKG 168  
CBSDRAW 37, 71, 149  
CBDSEXP 37, 161  
CBDSIMP 37, 158  
CBDSIOCP 138  
CBDSIODF 35, 123  
CBDSMIGR 86, 87  
CBDSPROD 35, 46, 133  
CBDSRDEV 170  
CBDSREP 37, 146  
CBDSWORK 36, 135  
CF channel path, migration enhancements 98  
CF duplexing 18  
CF sender (coupling facility sender) channel path  
  changing dynamically 58  
CF sender channel path  
  adding dynamically 58  
CFReport 49  
CFS channel path  
  sharing 281  
chained switches 42  
change  
  dynamic I/O 277, 281, 287, 291, 299, 307, 313, 325, 335  
change log data set, extending allocation space for 26  
CHANGE\_LOG 29

- changing
  - partition name, migration 109
- channel path 277, 285, 291, 299, 317, 328, 336
  - adding dynamically 58
  - changing dynamically 58
  - CHPID statement 97
  - compare report, example 227
  - connectivity report, example 186
  - deleting dynamically 58
  - detail report, example 184
  - dynamic I/O characteristic field 57
  - migration enhancement 97
  - summary report, example 181
- channel subsystem
  - creating IOCDS file 278
  - definition of 277
- channel subsystem report, example 175
- CHID report, example 178
- CHLOG\_EXTENSION 26
- CHPID macro 282, 302
- CHPID Mapping Tool 49
- CHPID report 71
- CHPID statement 97
- CNTLUNIT macro 282, 302
- CNTLUNIT statement 101
- coexistence considerations 39
- command
  - CPACCESS 294
  - QUERY
  - CONFIGMODE 315
- commands
  - TRACE 249
  - TRACE, HCM 251
- compare
  - IODFs or CSS/OS Reports, batch 151
- compare reports
  - channel path 227
  - control unit 229
  - control unit attachment 228
  - CSS / OS device 235
  - device 230
  - device attachment 229
  - OS console 234
  - OS device 234
  - partition 226
  - processor 223
  - switch 231
  - switch configuration detail 233
  - switch detail 232
- compatibility 39
  - IODF 39
- component ID 237
- CONFIG OS batch utility 88
- CONFIG PR batch utility 88
- CONFIG SW batch utility 88
- configuration file, HCM 36, 75
- configuration mode
  - checking status 315
  - controlling 315
  - definition 291, 314
  - disabling 315
  - enabling 315
  - interruptions to 316
- configuration reports
  - CF channel path connectivity report, example 186
  - channel path detail report, example 184
  - channel path summary report, example 181
- configuration reports (*continued*)
  - channel subsystem reports, example 175
  - control unit detail report, example 187
  - control unit summary report, example 187
  - CTC report, example 197
  - device detail report, example 189
  - device summary report, example 189
  - I/O definition reference, example 221
  - IOCDS report, example 179
  - LCU report, example 222
  - operating system report, example 195
  - operating system summary report, example 195
  - partition report, example 179
  - print with batch 145
  - problem determination 241
  - processor summary report, example 175
  - supported hardware report 199
  - switch configuration detail report, example 194
  - switch configuration summary report, example 194
  - switch detail report, example 193
  - switch report, example 193
  - switch summary report 193
  - VM console report, example 196
  - VM device detail report, example 196
  - VM device report, example 195
- configuration token
  - adding to IOCDS file 293
  - definition 291
- connections of switches, possibilities 41
- connectivity report, example 186
- console
  - report, example 196
- control unit
  - adding dynamically 59
  - attachment compare report, example 228
  - changing dynamically 60
  - compare report, example 229
  - configuration report, example 187
  - deleting dynamically 60
  - dynamic I/O characteristic field 57
- control unit model 81
- controller
  - adding 3390 DASDs to 304, 317
- copying
  - IODF, HCD function 143
- coupling facility connection report 71
- coupling facility control unit
  - definition changed 62
  - definition created 62
  - definition deleted 63
- coupling facility device
  - definition created 62
  - definition deleted 63
- CP (Control Program)
  - storage
    - adding for more SCMBKs 308
- CPACCESS command 294
- creating
  - graphical configuration report, batch 148
- CSS (channel subsystem)
  - configuration report, example 175
- CSS/operating system device compare report, example 235
- CSS/OS report, compare with batch 151
- CTC Connection List 70
- CTC connection report
  - report, example 197
- CU report 71

customizing z/VM HCD 25

## D

DASD (direct access storage device)  
 additional actions for dynamic change 56, 57  
DASD (Direct Access Storage Device)  
 adding to 3990 controller 304, 317  
 replacing 3380 with RAMAC 321  
data space 28  
data, subchannel measurement  
 adding more storage space for 295, 308  
DCF 71  
ddnames  
 alternate 173  
 standard 172  
DDR swap  
 planning 57  
dedicated connection 41  
default  
 disabling dynamic I/O 292, 308  
 initializing new devices 295  
definition of  
 channel subsystem 277  
 configuration mode 291  
 configuration token 291  
 dynamic I/O configuration 277, 291  
 EMIF-capable processors in LPAR mode 281  
 I/O configuration 277  
 LCSS-capable processors in LPAR mode 281  
 logical partition 281  
 LPAR mode 281  
delay device regrouping 28  
deleting  
 console list, migration 109  
 device, migration 109  
 switch-to-switch connection, migration 109  
device  
 adding dynamically 56  
 attachment compare report, example 229  
 changing dynamically 57  
 compare report, example 230  
 compare, CSS/operating system 235  
 deleting dynamically 56  
 detail report, example 189  
 dynamic I/O characteristic field 57  
 installation requirement 53, 56  
 summary report, example 189  
device sensing 9  
DEVICES statement  
 using to prevent dynamic I/O changes on devices 295  
diagnostic information and tools 245  
diagnostic messages 198  
different IODF levels 39  
disable  
 configuration mode 315  
 dynamic I/O changes  
 for all other logical partitions 310  
 for all other operating systems 310  
 for your z/VM system 310  
display  
 status  
 configuration mode 315  
duplicate control unit 82  
DYN operand  
 IOCP utility 293

dynamic configuration  
 changing characteristic field 57, 59, 60  
 characteristic field  
 channel path 59  
 control unit 60  
 I/O device 57  
 creating new IOCDS 53  
 LPAR mode change 55  
dynamic connection 41  
dynamic I/O  
 before Dynamic I/O 281  
 commands  
 SET CONFIGMODE 315  
 definition 277, 291  
 disabling  
 in the hardware 292  
 enabling  
 for other logical partitions 294  
 in the software 294  
 functions available  
 for channel paths 285, 287  
 for control units 285, 288  
 for I/O devices 286, 289  
 for logical partitions 286, 290  
 hardware 285  
 software 287  
 switching the active IOCDS file 287, 290  
 migrating to 291  
 return codes from the hardware 335  
 using 313  
dynamic I/O commands  
 SET CONFIGMODE 315  
dynamic I/O configuration 12  
dynamic I/O features  
 for other logical partitions 294  
dynamic switch 41  
DYNAMIC\_I/O operand  
 FEATURES statement 294

## E

EMIF-capable processor in LPAR mode  
 adding 3490 tape drives to logical partitions 319  
 definition 281  
enable  
 after initialization  
 initialization of new devices 295  
 SET DEVICES command 295  
 SET DYNAMIC\_I/O command 295  
 configuration mode 315  
 dynamic I/O changes  
 in the hardware 292  
 in the software 294  
enhanced migration 87  
enter  
 configuration mode 315  
entry switch 41  
environment for HCD 16  
errors  
 during IODF statements processing 240  
 during migration 116  
ESCON channel path  
 sharing 281  
ESCON director, CTC connection 70  
example  
 in this book 279

- exits
  - configuration mode 315
- expand
  - SCMBK space 295, 308
- export
  - IODF 160
- extended migration 87
- extending allocation space 26

## F

- fabric 41
- failure, diagnosis 237
- FCP device data 140
- FCP SAN configuration template file 141
- FEATURES statement
  - updating to allow dynamic I/O changes 294
- FICON
  - cascade switching 41
  - switch fabric 41
- FICON switches 41
- file
  - IOCDS
    - adding configuration token to 293
    - bringing online 283
    - creating 278
    - directing flow of I/O data 278
    - generating 293
    - writing to SE hard disk 293
- font for graphical reports 27
- formatting type for graphical reports 27
- FUNCTION statement 96

## G

- generate
  - IOCDS file 293
- GML 71
- graphical configuration report
  - create with batch 148
  - example 222
  - LCU report, example 222
  - problem determination 241
- graphical representation 71

## H

- hardware
  - enabling dynamic I/O in 292
  - return codes 335
- hardware and software configuration
  - change 52, 55
  - matching 21, 53
- Hardware Configuration Definition 8
- Hardware Configuration Manager 8
- hardware functions available
  - dynamic I/O 285
  - for channel paths 285
  - for control units 285
  - for I/O devices 286
  - for logical partitions 286
  - switching the active IOCDS file 287
- hardware mode
  - LPAR
    - building an IOCP source file for 303
    - definition 281

- hardware report 199
- HCD 8
- HCD (Hardware Configuration Definition)
  - abnormal termination 238
  - files relationship 15
  - product identifier 237
- HCD function
  - build production IODF 133
  - build work IODF 135
  - compare IODFs or CSS/OS reports 151
  - copy IODF 143
  - create graphical configuration reports 148
  - export IODF 160
  - import IODF 158
  - print configuration reports 145
- HCD panel
  - activate new configuration 55
- HCD profile 47
- HCD reports 37
- HCD\_CNTL 123
- HCDIODFT 123
- HCM 8
- HCM configuration file 36, 75
- HCM reports 37
- HCPRIO ASSEMBLE file
  - future device definition enhancements 278
- HCPSYS ASSEMBLE file
  - future system definition enhancements 278
- header record 123
- help facility in z/VM 240
- HSA
  - storing IOCDS file 278
- HSA (hardware system area)
  - description 21
- HSA token 133

## I

- I/O (input/output)
  - configuration
    - task overview 275
  - data
    - directing flow of 278
- I/O component
  - changing definition 55
- I/O concurrency level 189
- I/O configuration
  - adding
    - 3390 DASDs to 3990 controller 304, 317
    - 3490 tape drives to logical partitions 319
  - bringing online 283
  - changing
    - 3380 DASDs to RAMAC DASDs 321
    - before Dynamic I/O 281
    - before z/VM 2.1.0 277
  - defining
    - hardware view 278, 282
    - software view 278, 283
  - definition of 277
  - hardware and software match 21, 53
  - replacing
    - 3380 DASDs with RAMAC DASDs 321
  - sharing
    - 3490 tape drives between logical partitions 319
  - writing to disk 283
- I/O configuration definition reference
  - configuration report, example 221

- I/O configuration definition reference *(continued)*
  - print 145
- I/O configuration repositories
  - HCM configuration file 75
  - IODF for z/VM HCD 75
- I/O configuration statements 140
- I/O Definition File 7, 8
- ID macro 282, 302
- ID statement 93
- identifying problems 237
- import
  - IODF, batch 158
- increase
  - SCMBK space 295, 308
- increased system availability 12
- incremental update 106, 107
- initialization problems 243
- input parameter string 120
- installation-static device 66
- interface
  - HCD functions 119
- interrupt
  - configuration mode 316
- introduction 9
- Invalid Configuration Bit
  - definition 316
  - resetting 317
- invoking HCD functions 119
- invoking REXX utilities 119
- IOCDS (I/O configuration data set)
  - creating new 53
  - description 21
- IOCDS file
  - adding configuration token to 293
  - bringing online 283
  - creating 278
  - directing flow of I/O data 278
  - generating 293
  - report, example 179
  - writing to disk 283
  - writing to SE hard disk 293
- IOCONFIG statement 90
- IOCP
  - migrating from 75
- IOCP (I/O configuration program)
  - description 21
- IOCP migration 75
- IOCP source file
  - adding configuration token to 293
  - checking syntax of 293
  - reading 293
  - validating 293
- IOCP source file, sample 331
- IOCP utility
  - generating configuration token with 293
- IODEVICE macro 282, 302
- IODEVICE statement 102
- IODF 7, 8
  - activity log 38
  - change log 38
  - create 124
  - validated work IODF 50
- IODF (I/O definition file)
  - build production IODF, batch 133
  - build work IODF, batch 135
  - compare reports, example 223
  - compare with batch 151

- IODF (I/O definition file) *(continued)*
  - different levels 39
  - export 160
  - import with batch 158
  - release level compatibility 39
- IODF compatibility 39
- IODF header record 123
- IODF statement 51
- IPL (Initial Program Load)
  - creating software I/O configuration 278, 283
  - errors 240
  - using to enable dynamic I/O 294

## K

- keywords in profile 26

## L

- LCSS 281
- LCU (logical control unit)
  - report, example 222
- legend, CTC report 197
- lock-step approach 12
- lock-step process 296, 300, 309, 313, 327
- logging 37
- logical channel subsystem (LCSS) 281
- LP
  - adding
    - 3490 tape drives to 319
  - definition 281
  - preventing others from using dynamic I/O 294
  - sharing
    - 3490 tape drives between 319
    - channel paths 281
- LPAR (logically partitioned) mode
  - activating change 55
  - continue I/O configuration change
    - without system reset 66
  - dynamic configuration
    - activating change 55
    - recovery 66
  - recover original I/O configuration
    - with system reset 66
    - without system reset 66
  - recovery 66
- LPAR mode
  - definition 281
  - replacing 3380 DASDs with RAMAC DASDs 321
  - understanding effects of dynamic I/O 307

## M

- macro
  - IOCP
    - CHPID 282, 302
    - CNTLUNIT 282, 302
    - ID 282, 302
    - IODEVICE 282, 302
    - RESOURCE 282, 302
- maintain IODF 34
- MAP\_CUTYPE 28, 80
- mapping of migrated data 82
- master configuration file 31
- master IODF 33
- MCF data set, extending allocation space for 26

- MCF\_EXTENSION 26
- measurement block, subchannel
  - adding more storage space for 295, 308
- measurement data, subchannel
  - adding more storage space for 295, 308
- message list 115
- message log 246
- messages
  - overview 245
  - reason code 238
- migrate
  - to dynamic I/O 291
- MIGRATE\_EXTENDED 47
- migrating your environment 75
- migration
  - log 116
  - solving errors 115
- Migration from an IOCP 75
- migration from IOCP 75
- migration log 246
- minimum installed port range 91
- mode, configuration
  - checking status 315
  - controlling 315
  - definition 291, 314
  - disabling 315
  - enabling 315
  - interruptions to 316
- module prefix 237
- multiple IODFs 32
- multiple logical channel subsystems 281
- MVS devices 199

## N

- naming convention of activity log 31
- naming convention of IODFs 31
- NEW\_DEVICES\_INITIALIZED\_WHEN\_ADDED
  - operand 295
- NOTDYNAMIC\_I/O operand
  - DEVICES statement 295

## O

- offline
  - taking devices 322
- online
  - bringing I/O configuration 283
- operating requirements for HCD 16
- operating system configuration
  - reports, example 195
- operating system configurations 140
- options for text reports 27
- OS console compare report, example 234
- OS device compare report, example 234
- OS report 70
- OSA channel path
  - sharing 281
- overview of HCD 9

## P

- parallel access volumes 56
- partial migration 106
- partition
  - compare report, example 226

- partition (*continued*)
  - configuration report, example 179
  - migration enhancement 95
  - RESOURCE statement 95
- PAV 56
- PCHID 49
- PCIe function 96
- PCIe function compare report, example 225
- PCIe function report, example 176
- performance
  - benefits of using configuration mode 315
- physical channel identifier 49
- POR (power-on reset) 12
- port configuration 93
- port matrix 41
- PORT statement 92
- PORTCF statement 93
- power-on reset
  - bringing I/O configuration online with 283
  - enabling dynamic I/O with 294
- PR/SM 17
- pre-migration activities 80
- preparing for migration 80
- prevent
  - logical partition from using dynamic I/O 294
- printing
  - configuration reports, batch 145
  - problem determination 241
- privilege class 17
- problem determination 237
  - abnormal termination 238
  - diagnostic information and tools 245
  - errors during IODF statements processing 240
  - graphical reports 241
  - identifying problems 237
  - initialization of HCD 243
  - system abend code '00F' 238
  - system abend code other than '00F' 239
  - textual reports 241
  - trace facility 246
  - UIMs 244
- problem reporting data bases 253
- process configuration data 45
- processor
  - compare report, example 223
  - configuration report, example 175
- processor configuration token
  - description 21
- processor configurations 140
- product identifier 237
- production IODF
  - build with batch 133
  - naming convention 31
- profile 47
- profile for z/VM HCD 26
- programming interface for HCD 119
- programming interface information 375
- protocol support for control units, migration 81

## Q

- query
  - status
    - configuration mode 315
- QUERY CONFIGMODE command 315

## R

- RAMAC DASD
  - replacing 3380 DASDs with 321
- RDEV 20
- RDEV control block 12, 13
- RDEVICE statement
  - using when dynamic I/O is disabled 293
- RDEVICE statements 10
- re-migrate IOCP input files 47
- real storage
  - adding for more SCMBKs 295, 308
  - directing flow of I/O data 278
- reason code 238
- receiving an IODF 37
- recover original I/O configuration
  - LPAR mode
    - with system reset 66
    - without system reset 66
- recovery
  - configuration change 65, 66
  - continue I/O configuration change
    - with re-IPL 65
    - without re-IPL 65
  - dynamic configuration change 64
    - procedure 65
    - with re-IPL 65
    - without re-IPL 65, 66
  - procedure
    - dynamic configuration 65
  - recover original I/O configuration
    - with re-IPL 65
    - without re-IPL 65, 66
- rejection of dynamic activation 64
- relationship of files 15
- release level compatibility 39
- replace
  - 3380 DASDs with RAMAC DASDs 321
- replacing objects through migration 106
- reporting problems 253
- reports
  - HCD 37
  - HCM 37
- reports, text, options 27
- repositories
  - HCM configuration file 75
  - IODF for z/VM HCD 75
- request
  - sense ID
    - using to create software I/O configuration 283
- RESET operand
  - SET CONFIGMODE command 317
- reset, power-on
  - bringing I/O configuration online with 283
  - enabling dynamic I/O with 294
- RESOURCE macro 282, 302
- RESOURCE statement 95
- return code
  - from the hardware 335
- REXX utilities 119

## S

- sample IOCP source file 331
- scaling factor for graphical reports 27
- SCMBK operand
  - STORAGE statement 295

- searching data bases 253
- sense ID request
  - using to create software I/O configuration 283
- sequence of migration 80
- SET CONFIGMODE command 315
- SET RDEVICE command
  - using when dynamic I/O is disabled 293
- SET\_DEVICES operand
  - FEATURES statement 295
- SET\_DYNAMIC\_I/O operand
  - FEATURES statement 295
- setting up z/VM HCD 25
- sharing IODFs 32, 39
- shut down
  - z/VM
    - to enable dynamic I/O configuration 294, 296
- single IODF 32
- single point of control 12
- software
  - enabling dynamic I/O in 294
- software functions available
  - dynamic I/O 287
  - for channel paths 287
  - for control units 288
  - for I/O devices 289
  - for logical partitions 290
  - switching the active IOCDS file 290
- software only
  - change 54, 55
- solving migration errors 115
- space
  - storage
    - adding for more SCMBKs 295, 308
- stand-alone CTC adapter 70
- standard DD names 172
- statement
  - RDEVICE
    - using when dynamic I/O is disabled 293
- status
  - checking configuration mode 315
- storage
  - directing flow of I/O data 278
  - SCMBK
    - expanding 295
- STORAGE statement
  - using to add more SCMBK space 295
- storage, SCMBK operand
  - expanding 295
- subchannel measurement block
  - adding more storage space for 295, 308
- subchannel measurement data
  - adding more storage space for 295, 308
- subsystem, channel
  - creating IOCDS file 278
  - definition of 277
- supported hardware report 199
- SWCONF statement 92
- switch
  - chained switches 42
  - compare report, example 231, 232
  - dedicated connection 41
  - dynamic connection 41
  - dynamic switch 41
  - entry switch 41
  - possible connections 41
  - report, example 193

- switch configuration
  - compare report, example 233
  - report, example 194
- switch configurations 140
- SWITCH keyword 41
- SWITCH statement 91
- symptom table 237
- syntax 88
- system abend code
  - '00F' 238
  - other than '00F' 239
- SYSTEM CONFIG file 51
- system configuration file
  - backing up before enabling dynamic I/O 294
  - updating for dynamic I/O 294
- system environment
  - dynamic configuration
    - DDR swap 57
    - device 57
    - planning 57

## T

- tape drive
  - sharing 3490s between logical partitions 319
- target IODF 163
- terminal
  - of initialization 243
- testing
  - activation 64
- textual configuration report, how to print 69
- textual configuration reports, examples 175
- token
  - checking software and hardware configuration match 21
- token, configuration
  - adding to IOCDS file 293
  - definition 291
- TRACE command 249
- TRACE command and HCM 251
- TRACE command in HCD profile 27
- TRACE command via HCD profile 251
- trace facility 246

## U

- UIM
  - problem determination 244
- UIM (unit information module)
  - description 20
  - using with HCD 371
- updating parts through migration 106
- usage type 109

## V

- validated work IODF 50
- VARY (real device) command
  - using when dynamic I/O is disabled 293
- viewing processor configuration token 22
- virtual machine
  - console report, example 196
  - device detail report, example 196
  - device report, example 195

## W

- wait state 240
- warning
  - device definition enhancements, future 278
  - system definition enhancements, future 278
- work IODF
  - build with batch 135
  - naming convention 31
- write
  - I/O configuration to disk 283
- WWPN Prediction Tool
  - FCP SAN configuration template file 141

## Z

- z/VM HCD 8
- z/VM HCD profile 26
- z/VM HCD TCP/IP dispatcher for HCM 25
- z/VM help facility 240





Product Number: 5741-A07

Printed in USA

SC24-6198-05

