

Enterprise COBOL for z/OS



Programming Guide

Version 5.2

Enterprise COBOL for z/OS



Programming Guide

Version 5.2

Note

Before using this information and the product it supports, be sure to read the general information under “Notices” on page 825.

| **Fourth edition (March 2019)**

| This edition applies to Version 5 Release 2 of IBM Enterprise COBOL for z/OS (program number 5655-W32) and to
| all subsequent releases and modifications until otherwise indicated in new editions. Make sure that you are using
| the correct edition for the level of the product.

| You can view or download softcopy publications free of charge at www.ibm.com/shop/publications/order/.

© Copyright IBM Corporation 1991, 2018.

US Government Users Restricted Rights – Use, duplication or disclosure restricted by GSA ADP Schedule Contract with IBM Corp.

Contents

Tables	xiii
-------------------------	-------------

Preface	xv
--------------------------	-----------

About this information	xv
How this information will help you	xv
Abbreviated terms	xv
Comparison of commonly used terms	xvi
How to read syntax diagrams	xvi
How examples are shown	xviii
Additional documentation and support	xviii
Summary of changes	xviii
Version 5 Release 2 with PTFs installed	xix
Version 5 Release 2	xix
How to send your comments	xx
Accessibility	xx
Interface information	xxi
Keyboard navigation	xxi
Accessibility of this information	xxi
IBM and accessibility	xxi

Part 1. Coding your program 1

Chapter 1. Structuring your program	3
--	----------

Identifying a program	3
Identifying a program as recursive	4
Marking a program as callable by containing programs	4
Setting a program to an initial state.	5
Changing the header of a source listing	5
Describing the computing environment	5
Example: FILE-CONTROL entries	6
Specifying the collating sequence	6
Defining symbolic characters	8
Defining a user-defined class	8
Defining files to the operating system	8
Describing the data	11
Using data in input and output operations	11
Comparison of WORKING-STORAGE and LOCAL-STORAGE	14
Using data from another program	16
Processing the data	17
How logic is divided in the PROCEDURE DIVISION	18
Declaratives	21

Chapter 2. Using data	23
--	-----------

Using variables, structures, literals, and constants	23
Using variables	23
Using data items and group items	24
Using literals	25
Using constants	26
Using figurative constants	26
Assigning values to data items	27
Examples: initializing data items	28

Initializing a structure (INITIALIZE)	30
Assigning values to elementary data items (MOVE)	32
Assigning values to group data items (MOVE)	33
Assigning arithmetic results (MOVE or COMPUTE)	34
Assigning input from a screen or file (ACCEPT)	34
Displaying values on a screen or in a file (DISPLAY)	35
Displaying data on the system logical output device	36
Using WITH NO ADVANCING	37
Using intrinsic functions (built-in functions)	38
Using tables (arrays) and pointers	39
Storage and its addressability	39
Restrictions for AMODE	40
Settings for RMODE	41
Storage restrictions for passing data	41
Location of data areas	42
Storage for LOCAL-STORAGE data	42
Storage for external data	42
Storage for QSAM input-output buffers	42

Chapter 3. Working with numbers and arithmetic	43
---	-----------

Defining numeric data	43
Displaying numeric data	45
Controlling how numeric data is stored	46
Formats for numeric data	47
External decimal (DISPLAY and NATIONAL) items	47
External floating-point (DISPLAY and NATIONAL) items	48
Binary (COMP) items	48
Native binary (COMP-5) items	49
Packed-decimal (COMP-3) items	50
Internal floating-point (COMP-1 and COMP-2) items	50
Examples: numeric data and internal representation	51
Data format conversions	52
Conversions and precision	52
Sign representation of zoned and packed-decimal data	53
Checking for incompatible data (numeric class test)	54
Performing arithmetic	56
Using COMPUTE and other arithmetic statements	56
Using arithmetic expressions	57
Using numeric intrinsic functions	57
Using math-oriented callable services	59
Using date callable services	60
Examples: numeric intrinsic functions	60
Fixed-point contrasted with floating-point arithmetic	62
Floating-point evaluations	63
Fixed-point evaluations	63

Arithmetic comparisons (relation conditions) . . .	63
Examples: fixed-point and floating-point evaluations	64
Using currency signs	65
Example: multiple currency signs	66

Chapter 4. Handling tables 67

Defining a table (OCCURS)	67
Nesting tables	69
Example: subscripting	70
Example: indexing	70
Referring to an item in a table	70
Subscripting	71
Indexing	72
Putting values into a table	73
Loading a table dynamically.	73
Initializing a table (INITIALIZE)	73
Assigning values when you define a table (VALUE)	75
Example: PERFORM and subscripting	76
Example: PERFORM and indexing.	77
Creating variable-length tables (DEPENDING ON)	78
Loading a variable-length table.	80
Assigning values to a variable-length table	81
Complex OCCURS DEPENDING ON	81
Example: complex ODO	82
Effects of change in ODO object value	83
Searching a table	85
Doing a serial search (SEARCH)	86
Doing a binary search (SEARCH ALL)	87
Sorting a table	88
Processing table items using intrinsic functions	89
Example: processing tables using intrinsic functions	89
Working with unbounded tables and groups	90
Example: Using unbounded tables for parsing XML documents.	90

Chapter 5. Selecting and repeating program actions 93

Selecting program actions	93
Coding a choice of actions	93
Coding conditional expressions.	98
Repeating program actions	101
Choosing inline or out-of-line PERFORM	102
Coding a loop	103
Looping through a table.	103
Executing multiple paragraphs or sections.	104

Chapter 6. Handling strings 105

Joining data items (STRING)	105
Example: STRING statement	106
Splitting data items (UNSTRING)	107
Example: UNSTRING statement	108
Manipulating null-terminated strings	110
Example: null-terminated strings	111
Referring to substrings of data items.	111
Reference modifiers	113
Example: arithmetic expressions as reference modifiers	114

Example: intrinsic functions as reference modifiers	114
Tallying and replacing data items (INSPECT).	115
Examples: INSPECT statement.	115
Converting data items (intrinsic functions).	116
Changing case (UPPER-CASE, LOWER-CASE)	117
Transforming to reverse order (REVERSE)	117
Converting to numbers (NUMVAL, NUMVAL-C)	117
Converting from one code page to another	118
Evaluating data items (intrinsic functions).	119
Evaluating single characters for collating sequence	119
Finding the largest or smallest data item	120
Finding the length of data items	122
Finding the date of compilation	123

Chapter 7. Processing data in an international environment 125

COBOL statements and national data	126
Intrinsic functions and national data.	128
Unicode and the encoding of language characters	129
Using national data (Unicode) in COBOL	130
Defining national data items	130
Using national literals	131
Using national-character figurative constants	132
Defining national numeric data items	133
National groups	133
Using national groups	134
Storage of character data	137
Converting to or from national (Unicode) representation	137
Converting alphanumeric, DBCS, and integer to national (MOVE)	138
Converting alphanumeric or DBCS to national (NATIONAL-OF)	139
Converting national to alphanumeric (DISPLAY-OF)	139
Overriding the default code page.	140
Conversion exceptions	140
Example: converting to and from national data	140
Processing UTF-8 data	141
Using intrinsic functions to process UTF-8 encoded data	142
Processing Chinese GB 18030 data	146
Comparing national (UTF-16) data	147
Comparing two class national operands	148
Comparing class national and class numeric operands	148
Comparing national numeric and other numeric operands	149
Comparing national and other character-string operands	149
Comparing national data and alphanumeric-group operands.	149
Coding for use of DBCS support	150
Defining DBCS data	150
Using DBCS literals	150
Testing for valid DBCS characters	151
Processing alphanumeric data items that contain DBCS data	152

Chapter 8. Processing files 153

File organization and input-output devices	153
Choosing file organization and access mode	155
Format for coding input and output	156
Allocating files	157
Checking for input or output errors	158

Chapter 9. Processing QSAM files . . . 159

Defining QSAM files and records in COBOL	159
Establishing record formats	160
Setting block sizes	167
Coding input and output statements for QSAM files	170
Opening QSAM files	170
Dynamically creating QSAM files	171
Adding records to QSAM files	172
Updating QSAM files	172
Writing QSAM files to a printer or spooled data set	172
Closing QSAM files	173
Handling errors in QSAM files	174
Working with QSAM files	174
Defining and allocating QSAM files	174
Retrieving QSAM files	177
Ensuring that file attributes match your program	178
Using striped extended-format QSAM data sets	180
Allocation of buffers for QSAM files	181
Accessing z/OS UNIX files using QSAM	181
Processing QSAM ASCII files on tape	182

Chapter 10. Processing VSAM files . . . 185

VSAM files	186
Defining VSAM file organization and records	187
Specifying sequential organization for VSAM files	188
Specifying indexed organization for VSAM files	188
Specifying relative organization for VSAM files	190
Specifying access modes for VSAM files	191
Defining record lengths for VSAM files	191
Coding input and output statements for VSAM files	193
File position indicator	195
Opening a file (ESDS, KSDS, or RRDS)	195
Reading records from a VSAM file	198
Updating records in a VSAM file	199
Adding records to a VSAM file	199
Replacing records in a VSAM file	200
Deleting records from a VSAM file	200
Closing VSAM files	200
Handling errors in VSAM files	201
Protecting VSAM files with a password	202
Example: password protection for a VSAM indexed file	202
Working with VSAM data sets under z/OS and z/OS UNIX	202
Defining VSAM files	203
Creating alternate indexes	204
Allocating VSAM files	206
Sharing VSAM files through RLS	207

Allocation of record areas for VSAM files	209
Improving VSAM performance	209
Extended addressability support	211

Chapter 11. Processing line-sequential files 213

Defining line-sequential files and records in COBOL	213
Describing the structure of a line-sequential file	214
Control characters in line-sequential files	214
Allocating line-sequential files	214
Coding input-output statements for line-sequential files	215
Opening line-sequential files	216
Reading records from line-sequential files	216
Adding records to line-sequential files	217
Closing line-sequential files	217
Handling errors in line-sequential files	218

Chapter 12. Sorting and merging files . . . 219

Sort and merge process	220
Describing the sort or merge file	220
Describing the input to sorting or merging	221
Example: describing sort and input files for SORT	221
Coding the input procedure	222
Describing the output from sorting or merging	223
Coding the output procedure	224
Example: coding the output procedure when using DFSORT	224
Restrictions on input and output procedures	225
Defining sort and merge data sets	225
Sorting variable-length records	226
Requesting the sort or merge	226
Setting sort or merge criteria	227
Example: sorting with input and output procedures	228
Choosing alternate collating sequences	229
Preserving the original sequence of records with equal keys	230
Determining whether the sort or merge was successful	230
Stopping a sort or merge operation prematurely	231
Improving sort performance with FASTSORT	231
FASTSORT requirements for JCL	231
FASTSORT requirements for sort input and output files	231
Checking for sort errors with NOFASTSORT	233
Controlling sort behavior	234
Changing DFSORT defaults with control statements	235
Allocating storage for sort or merge operations	235
Allocating space for sort files	236
Using checkpoint/restart with DFSORT	236
Sorting under CICS	237
CICS SORT application restrictions	237

Chapter 13. Handling errors 239

Requesting dumps	239
Handling errors in joining and splitting strings	240

Handling errors in arithmetic operations	240
Example: checking for division by zero	241
Handling errors in input and output operations	241
Using the end-of-file condition (AT END)	243
Coding ERROR declaratives	244
Using file status keys	245
Example: file status key	246
Using VSAM status codes (VSAM files only)	246
Example: checking VSAM status codes	247
Coding INVALID KEY phrases	249
Example: FILE STATUS and INVALID KEY	249
Handling errors when calling programs	250
Writing routines for handling errors	250

Part 2. Compiling and debugging your program 253

Chapter 14. Compiling under z/OS 255

Compiling with JCL	255
Using a cataloged procedure	256
Writing JCL to compile programs	260
Compiling under TSO	262
Example: ALLOCATE and CALL for compiling under TSO	263
Example: CLIST for compiling under TSO	264
Starting the compiler from an assembler program	265
Defining compiler input and output	266
Data sets used by the compiler under z/OS	267
Defining the source code data set (SYSIN)	269
Defining a compiler-option data set (SYSOPTF)	269
Specifying source libraries (SYSLIB)	270
Defining the output data set (SYSPRINT)	270
Directing compiler messages to your terminal (SYSTEM)	271
Creating object code (SYSLIN or SYSPUNCH)	271
Defining an associated-data file (SYSADATA)	271
Defining the Java-source output file (SYSJAVA)	272
Defining the library-processing output file (SYSMDECK)	272
Specifying compiler options under z/OS	272
Specifying compiler options in the PROCESS (CBL) statement	273
Example: specifying compiler options using JCL	274
Example: specifying compiler options under TSO	274
Compiler options and compiler output under z/OS	274
Compiling multiple programs (batch compilation)	275
Example: batch compilation	276
Specifying compiler options in a batch compilation	277
Example: precedence of options in a batch compilation	278
Example: LANGUAGE option in a batch compilation	278
Correcting errors in your source program	279
Generating a list of compiler messages	280
Messages and listings for compiler-detected errors	280
Format of compiler diagnostic messages	281

Severity codes for compiler diagnostic messages	282
---	-----

Chapter 15. Compiling under z/OS UNIX 283

Setting environment variables under z/OS UNIX	283
Specifying compiler options under z/OS UNIX	284
Compiling and linking with the cob2 command	285
Creating a DLL under z/OS UNIX	286
Example: using cob2 to compile and link under z/OS UNIX	286
cob2 syntax and options	287
cob2 input and output files	288
Compiling using scripts	289

Chapter 16. Compiling, linking, and running OO applications 291

Compiling, linking, and running OO applications under z/OS UNIX	291
Compiling OO applications under z/OS UNIX	291
Preparing OO applications under z/OS UNIX	292
Example: compiling and linking a COBOL class definition under z/OS UNIX	293
Running OO applications under z/OS UNIX	293
Compiling, linking, and running OO applications in JCL or TSO/E	295
Compiling OO applications in JCL or TSO/E	295
Preparing and running OO applications in JCL or TSO/E	296
Example: compiling, linking, and running an OO application using JCL	298
Using Java SDKs for z/OS	299
Object-oriented syntax, and Java 6, Java 7, or Java 8	300

Chapter 17. Compiler options 301

Option settings for 85 COBOL Standard conformance	304
Conflicting compiler options	304
ADATA	305
ADV	306
AFP	307
ARCH	307
ARITH	309
AWO	310
BLOCK0	310
BUFSIZE	312
CICS	312
CODEPAGE	313
COMPILE	316
COPYRIGHT	316
CURRENCY	317
DATA	318
DBCS	319
DECK	319
DIAGTRUNC	320
DISPSIGN	320
DLL	321
DUMP	322
DYNAM	323
EXIT	324

EXPORTALL	326
FASTSRT	327
FLAG	328
FLAGSTD	329
HGPR	331
INITCHECK	331
INTDATE	332
LANGUAGE	333
LINECOUNT	334
LIST	334
MAP	335
MAXPCF	336
MDECK	337
NAME	339
NSYMBOL	340
NUMBER	340
NUMCHECK	341
NUMPROC	343
OBJECT	344
OFFSET	345
OPTFILE	345
OPTIMIZE	346
OUTDD	348
PGMNAME	348
PGMNAME(COMPAT)	349
PGMNAME(LONGUPPER)	349
PGMNAME(LONGMIXED)	350
Usage notes	350
QUALIFY	351
QUOTE/APOST	352
RENT	352
RMODE	353
RULES	354
SEQUENCE	356
SERVICE	356
SOURCE	357
SPACE	357
SQL	358
SQLCCSID	359
SQLIMS	360
SSRANGE	361
STGOPT	362
TERMINAL	363
TEST	364
THREAD	366
TRUNC	368
TRUNC example 1	369
TRUNC example 2	370
VBREF	370
VLR	371
VSAMOPENFS	372
WORD	372
XMLPARSE	373
XREF	374
ZONECHECK	375
ZONEDATA	377
ZWB	379

Chapter 18. Compiler-directing statements 381

Chapter 19. Debugging 385

Debugging with source language	385
Tracing program logic	386
Finding and handling input-output errors	387
Validating data	387
Moving, initializing or setting uninitialized data	388
Generating information about procedures	388
Debugging using compiler options	390
Finding coding errors	390
Finding line sequence problems	391
Checking for valid ranges	391
Selecting the level of error to be diagnosed	392
Finding program entity definitions and references	394
Listing data items	394
Using the debugger	395
Getting listings	395
Example: short listing	397
Example: SOURCE and NUMBER output	399
Example: MAP output	400
Reading LIST output	405
Example: XREF output: data-name cross-references	421
Example: OFFSET compiler output	424
Example: VBREF compiler output	425

Part 3. Targeting COBOL programs for certain environments 427

Chapter 20. Developing COBOL programs for CICS 429

Coding COBOL programs to run under CICS	429
Getting the system date under CICS	431
Calling to or from COBOL programs	431
Determining the success of ECI calls	433
Compiling with the CICS option	433
Separating CICS suboptions	435
Integrated CICS translator	435
Using the separate CICS translator	436
CICS reserved-word table	437
Handling errors by using CICS HANDLE	438
Example: handling errors by using CICS HANDLE	439

Chapter 21. Programming for a DB2 environment 441

DB2 coprocessor	441
Coding SQL statements	442
Using SQL INCLUDE with the DB2 coprocessor	442
Using character data in SQL statements	443
Using national decimal data in SQL statements	444
Using national group items in SQL statements	444
Using binary items in SQL statements	445
Determining the success of SQL statements	445
Compiling with the SQL option	445
Separating DB2 suboptions	446

COBOL and DB2 CCSID determination	447
Code-page determination for string host variables in SQL statements	447
Programming with the SQLCCSID or NOSQLCCSID option	448
Differences in how the DB2 precompiler and coprocessor behave	449
Period at the end of EXEC SQL INCLUDE statements	449
EXEC SQL INCLUDE and nested COPY REPLACING	449
EXEC SQL and REPLACE or COPY REPLACING	449
Source code after an END-EXEC statement	450
Multiple definitions of host variables	450
EXEC SQL statement continuation lines	450
Bit-data host variables	450
SQL-INIT-FLAG	450
Choosing the DYNAM or NODYNAM compiler option	451

Chapter 22. Developing COBOL programs for IMS. 453

IMS SQL coprocessor	453
Coding SQLIMS statements	454
Using SQLIMS INCLUDE with the IMS SQL coprocessor	454
Using character data in SQLIMS statements	455
Using binary items in SQLIMS statements	455
Determining the success of SQLIMS statements	455
Compiling with the SQLIMS option	455
Separating IMS suboptions	456
Compiling and linking COBOL programs for running under IMS	457
Using object-oriented COBOL and Java under IMS	458
Calling a COBOL method from a Java application under IMS	458
Building a mixed COBOL-Java application that starts with COBOL	459
Writing mixed-language IMS applications	459

Chapter 23. Running COBOL programs under z/OS UNIX 463

Running in z/OS UNIX environments	463
Setting and accessing environment variables	464
Setting environment variables that affect execution	465
Runtime environment variables	465
Example: setting and accessing environment variables	466
Calling UNIX/POSIX APIs	466
Accessing main program parameters under z/OS UNIX	468
Example: accessing main program parameters under z/OS UNIX.	469

Part 4. Structuring complex applications 471

Chapter 24. Using subprograms 473

Main programs, subprograms, and calls	473
Ending and reentering main programs or subprograms	474
Transferring control to another program	475
Making static calls.	476
Making dynamic calls	477
AMODE switching	479
Performance considerations of static and dynamic calls	481
Making both static and dynamic calls	481
Examples: static and dynamic CALL statements	482
Calling nested COBOL programs	483
Making recursive calls	487
Calling to and from object-oriented programs	487
Using procedure and function pointers	487
Deciding which type of pointer to use	489
Calling alternate entry points	489
Making programs reentrant	490

Chapter 25. Sharing data 491

Passing data.	491
Describing arguments in the calling program	493
Describing parameters in the called program	494
Testing for OMITTED arguments	495
Coding the LINKAGE SECTION	495
Coding the PROCEDURE DIVISION for passing arguments	496
Grouping data to be passed	496
Handling null-terminated strings	496
Using pointers to process a chained list	497
Passing return-code information	500
Using the RETURN-CODE special register.	500
Using PROCEDURE DIVISION RETURNING	500
.	500
Specifying CALL . . . RETURNING	501
Sharing data by using the EXTERNAL clause.	501
Sharing files between programs (external files)	501
Example: using external files	502
Accessing main program parameters under z/OS	505
Example: accessing main program parameters under z/OS	505

Chapter 26. Creating a DLL or a DLL application 507

Dynamic link libraries (DLLs)	507
Compiling programs to create DLLs	508
Linking DLLs	509
Example: sample JCL for a procedural DLL application	510
Using CALL identifier with DLLs	510
Search order for DLLs in the z/OS UNIX file system.	511
Using DLL linkage and dynamic calls together	512
Using procedure or function pointers with DLLs	512
Calling DLLs from non-DLLs	513
Example: calling DLLs from non-DLLs	514
Using COBOL DLLs with C/C++ programs	515
Using DLLs in OO COBOL applications	516

Chapter 27. Preparing COBOL programs for multithreading	517
Multithreading	518
Choosing THREAD to support multithreading	519
Transferring control to multithreaded programs	519
Ending multithreaded programs	520
Processing files with multithreading	520
File-definition (FD) storage	521
Serializing file access with multithreading	521
Example: usage patterns of file input and output with multithreading	522
Handling COBOL limitations with multithreading	522

Part 5. Using XML and COBOL together 525

Chapter 28. Processing XML input	527
XML parser in COBOL	528
Accessing XML documents	530
Parsing XML documents	530
Writing procedures to process XML	532
XML events	534
Transforming XML text to COBOL data items	539
Parsing XML documents with validation	540
Parsing XML documents one segment at a time	543
Handling splits using the XML-INFORMATION special register	545
The encoding of XML documents	546
XML input document encoding	547
Parsing XML documents encoded in UTF-8	551
Handling XML PARSE exceptions	552
How the XML parser handles errors	554
Handling encoding conflicts	555
Terminating XML parsing	556
XML PARSE examples	557
Example: parsing a simple document	557
Example: program for processing XML	558
Example: parsing an XML document that uses namespaces	563
Example: parsing an XML document one segment at a time	566
Example: parsing XML documents with validation	568

Chapter 29. Producing XML output	571
Generating XML output	571
Controlling the encoding of generated XML output	576
Handling XML GENERATE exceptions	577
Example: generating XML	578
Program XGFX	578
Program Pretty	580
Output from program XGFX	582
Enhancing XML output	583
Example: enhancing XML output	583

Part 6. Developing object-oriented programs 587

Chapter 30. Writing object-oriented programs	589
Example: accounts	590
Subclasses	591
Defining a class	592
CLASS-ID paragraph for defining a class	594
REPOSITORY paragraph for defining a class	594
WORKING-STORAGE SECTION for defining class instance data	596
Example: defining a class	597
Defining a class instance method	597
METHOD-ID paragraph for defining a class instance method	598
INPUT-OUTPUT SECTION for defining a class instance method	599
DATA DIVISION for defining a class instance method	599
PROCEDURE DIVISION for defining a class instance method	600
Overriding an instance method	601
Overloading an instance method	602
Coding attribute (get and set) methods	603
Example: defining a method	604
Defining a client	606
REPOSITORY paragraph for defining a client	607
DATA DIVISION for defining a client	608
Comparing and setting object references	609
Invoking methods (INVOKE)	610
Creating and initializing instances of classes	614
Freeing instances of classes	616
Example: defining a client	616
Defining a subclass	617
CLASS-ID paragraph for defining a subclass	618
REPOSITORY paragraph for defining a subclass	618
WORKING-STORAGE SECTION for defining subclass instance data	619
Defining a subclass instance method	619
Example: defining a subclass (with methods)	620
Defining a factory section	621
WORKING-STORAGE SECTION for defining factory data	622
Defining a factory method	622
Example: defining a factory (with methods)	625
Wrapping procedure-oriented COBOL programs	630
Structuring OO applications	630
Examples: COBOL applications that run using the java command	631

Chapter 31. Communicating with Java methods	633
Accessing JNI services	633
Handling Java exceptions	634
Managing local and global references	636
Java access controls	637
Sharing data with Java	637
Coding interoperable data types in COBOL and Java	638
Declaring arrays and strings for Java	639
Manipulating Java arrays	640
Manipulating Java strings	642

Example: J2EE client written in COBOL	644
COBOL client (ConverterClient.cbl)	645
Java client (ConverterClient.java)	647

Part 7. Specialized processing . . . 649

Chapter 32. Interrupts and checkpoint/restart 651

Setting checkpoints	651
Designing checkpoints	652
Testing for a successful checkpoint	652
DD statements for defining checkpoint data sets	653
Messages generated during checkpoint	654
Restarting programs	654
Requesting automatic restart	655
Requesting deferred restart	655
Formats for requesting deferred restart	656
Resubmitting jobs for restart	657
Example: restarting a job at a specific checkpoint step	657
Example: requesting a step restart	657
Example: resubmitting a job for a step restart	657
Example: resubmitting a job for a checkpoint restart	658

Part 8. Improving performance and productivity 659

Chapter 33. Tuning your program . . . 661

Using an optimal programming style	661
Using structured programming	662
Factoring expressions	662
Using symbolic constants	662
Choosing efficient data types	662
Choosing efficient computational data items	663
Using consistent data types	663
Making arithmetic expressions efficient	664
Making exponentiations efficient	664
Using VOLATILE clauses efficiently	664
Handling tables efficiently	664
Optimization of table references	666
Optimizing your code	667
Optimization	667
Choosing compiler features to enhance performance	668
Performance-related compiler options	669
Evaluating performance	672
Running efficiently with CICS, IMS, or VSAM	672
Choosing static or dynamic calls	673

Chapter 34. Simplifying coding 675

Eliminating repetitive coding	675
Example: using the COPY statement	676
Using Language Environment callable services	677
Sample list of Language Environment callable services	678
Calling Language Environment services	679
Example: Language Environment callable services	680

Using the format 2 SORT statement to sort a table	681
---	-----

Part 9. Appendixes 683

Appendix A. Intermediate results and arithmetic precision 685

Terminology used for intermediate results	686
Example: calculation of intermediate results	687
Fixed-point data and intermediate results	687
Addition, subtraction, multiplication, and division	687
Exponentiation	688
Example: exponentiation in fixed-point arithmetic	689
Truncated intermediate results	690
Binary data and intermediate results	690
Intrinsic functions evaluated in fixed-point arithmetic	690
Integer functions	690
Mixed functions	691
Floating-point data and intermediate results	692
Exponentiations evaluated in floating-point arithmetic	693
Intrinsic functions evaluated in floating-point arithmetic	693
Arithmetic expressions in nonarithmetic statements	693

Appendix B. Converting double-byte character set (DBCS) data 695

DBCS notation	695
Alphanumeric to DBCS data conversion (IGZCA2D)	695
IGZCA2D syntax	695
IGZCA2D return codes	696
Example: IGZCA2D	697
DBCS to alphanumeric data conversion (IGZCD2A)	698
IGZCD2A syntax	698
IGZCD2A return codes	699
Example: IGZCD2A	699

Appendix C. XML reference material 701

XML PARSE exceptions with XMLPARSE(XMLSS)	
in effect	701
XML PARSE exceptions with	
XMLPARSE(COMPAT) in effect	703
XML PARSE exceptions that allow continuation	703
XML PARSE exceptions that do not allow continuation	707
XML GENERATE exceptions	710

Appendix D. EXIT compiler option . . 711

Using the user-exit work area	711
Calling from exit modules	712
Processing of INEXIT	712
INEXIT parameters	712
Processing of LIBEXIT	713
Processing of LIBEXIT with nested COPY statements	714
LIBEXIT parameters	715

Processing of PRTEXT	716
PRTEXT parameters	717
Processing of ADEXIT	717
ADEXIT parameters	718
Processing of MSGEXIT	719
MSGEXIT parameters	719
Customizing compiler-message severities	720
Example: MSGEXIT user exit	723
Error handling for exit modules	727
Using the EXIT compiler option with CICS, SQL and SQLIMS statements	728

Appendix E. JNI.cpy copybook 731

Appendix F. COBOL SYSADATA file contents 737

Compiler options that affect the SYSADATA file	737
SYSADATA record types	738
Example: SYSADATA	739
SYSADATA record descriptions	740
Common header section	741
Job identification record: X'0000'	743
ADATA identification record: X'0001'	744
Compilation unit start end record: X'0002'	744
Options record: X'0010'	745
External symbol record: X'0020'	755
Parse tree record: X'0024'	755
Token record: X'0030'	771
Source error record: X'0032'	785
Source record: X'0038'	785
COPY REPLACING record: X'0039'	786
Symbol record: X'0042'	787

Symbol cross-reference record: X'0044'	798
Nested program record: X'0046'	799
Library record: X'0060'	800
Statistics record: X'0090'	800
EVENTS record: X'0120'	801

Appendix G. Using sample programs 805

IGYTCARA: batch application	805
Input data for IGYTCARA	806
Report produced by IGYTCARA	807
Preparing to run IGYTCARA	808
IGYTCARB: interactive program	809
Preparing to run IGYTCARB	810
IGYTSALE: nested program application	812
Input data for IGYTSALE	813
Reports produced by IGYTSALE	815
Preparing to run IGYTSALE	818
Language elements and concepts that are illustrated	819

Notices 825

Trademarks	827
----------------------	-----

Glossary 829

List of resources 863

Enterprise COBOL for z/OS	863
Related publications	863

Index 865

Tables

1. FILE-CONTROL entries	6	41. Commands for compiling and linking a class definition	292
2. FILE SECTION entries	12	42. java command options for customizing the JVM	294
3. Assignment to data items in a program	27	43. Compiler options	301
4. Effect of RMODE and RENT compiler options on the RMODE attribute	41	44. Mutually exclusive compiler options	305
5. Ranges in value of COMP-5 data items	49	45. EBCDIC multibyte coded character set identifiers	315
6. Internal representation of numeric items	51	46. DISPLAY output with the DISPSIGN(COMPAT) option or the DISPSIGN(SEP) option specified.	321
7. NUMCLS(PRIM) and valid signs	55	47. Values of the LANGUAGE compiler option	333
8. NUMCLS(ALT) and valid signs	55	48. Mapping of removed options to new options	347
9. Order of evaluation of arithmetic operators	57	49. Severity levels of compiler messages	392
10. Numeric intrinsic functions	58	50. Using compiler options to get listings	396
11. Compatibility of math intrinsic functions and callable services	59	51. Terms used in MAP output	403
12. INTDATE(LILIAN) and compatibility of date intrinsic functions and callable services.	60	52. Symbols used in LIST and MAP output	404
13. INTDATE(ANSI) and compatibility of date intrinsic functions and callable services.	60	53. Compiler options in the INFO BYTE section	407
14. Hexadecimal values of the euro sign	65	54. Signature information bytes	407
15. COBOL statements and national data	126	55. Calls between COBOL and assembler under CICS	432
16. Intrinsic functions and national character data.	128	56. Compiler options required for the integrated CICS translator.	434
17. National group items that are processed with group semantics	136	57. Compiler options required for the separate CICS translator.	437
18. Encoding and size of alphanumeric, DBCS, and national data	137	58. TRUNC compiler options recommended for the separate CICS translator	437
19. Summary of file organizations, access modes, and record formats of COBOL files	155	59. Samples with POSIX function calls	467
20. QSAM file allocation.	175	60. Effects of termination statements.	474
21. Maximum record length of QSAM files	179	61. Methods for passing data in the CALL statement	492
22. Comparison of VSAM, COBOL, and non-VSAM terminology.	185	62. Compiler options for DLL applications	508
23. Comparison of VSAM data-set types	187	63. Binder options for DLL applications	509
24. VSAM file organization, access mode, and record format	188	64. Special registers used by the XML parser	532
25. Definition of VSAM fixed-length records	192	65. Results of processing-procedure changes to XML-CODE with XMLPARSE(XMLSS) in effect	535
26. Definition of VSAM variable-length records	192	66. Results of processing-procedure changes to XML-CODE with XMLPARSE(COMPAT) in effect	536
27. I/O statements for VSAM sequential files	194	67. Coded character sets for XML documents	547
28. I/O statements for VSAM relative and indexed files	194	68. Hexadecimal values of white-space characters.	548
29. Statements to load records into a VSAM file	197	69. Aliases for XML encoding declarations	550
30. Statements to update records in a VSAM file	199	70. Hexadecimal values of special characters for various EBCDIC CCSIDs	550
31. Methods for improving VSAM performance	209	71. XML events and special registers	557
32. Methods for checking for sort errors with NOFASTSORT	233	72. XML events and special registers	563
33. Methods for controlling sort behavior	234	73. XML events and special registers from parsing XML document with an undeclared namespace prefix	565
34. Compiler data sets	267	74. Encoding of generated XML if the ENCODING phrase is omitted	577
35. Block size of fixed-length compiler data sets	269	75. Structure of class definitions	592
36. Block size of variable-length compiler data sets	269	76. Structure of instance method definitions	598
37. Types of compiler output under z/OS	274	77. Structure of COBOL clients	606
38. Severity codes for compiler diagnostic messages	282	78. Conformance of arguments in a COBOL client	611
39. Input files to the cob2 command.	289		
40. Output files from the cob2 command	289		

79. Conformance of the returned data item in a COBOL client	613	106. PRTEXT processing	716
80. Structure of factory definitions	621	107. PRTEXT parameters	717
81. Structure of factory method definitions	623	108. ADEXIT processing	718
82. JNI services for local and global references	637	109. ADEXIT parameters	718
83. Interoperable data types in COBOL and Java	638	110. MSGEXIT processing	719
84. Interoperable arrays and strings in COBOL and Java	639	111. MSGEXIT parameters	720
85. Noninteroperable array types in COBOL and Java	640	112. FIPS (FLAGSTD) message categories	722
86. JNI array services	640	113. Actions possible in exit modules for CICS, SQL and SQLIMS statements	729
87. Services that convert between jstring references and national data	642	114. SYSADATA record types	738
88. Services that convert between jstring references and alphanumeric data	643	115. SYSADATA common header section	741
89. Performance-related compiler options	669	116. SYSADATA job identification record	743
90. Performance-tuning worksheet	672	117. ADATA identification record	744
91. Language Environment callable services	678	118. SYSADATA compilation unit start end record	744
92. Comparison of format 1 and format 2 SORT statements	681	119. SYSADATA options record	745
93. IGZCA2D return codes	696	120. SYSADATA external symbol record	755
94. IGZCD2A return codes	699	121. SYSADATA parse tree record	755
95. Reason codes for XML PARSE exceptions that are unique to Enterprise COBOL	702	122. SYSADATA token record	771
96. XML PARSE exceptions that allow continuation	703	123. SYSADATA source error record	785
97. XML PARSE exceptions that do not allow continuation (for XMLPARSE(COMPAT))	707	124. SYSADATA source record	785
98. XML GENERATE exceptions	710	125. SYSADATA COPY REPLACING record	786
99. Layout of the user-exit work area	711	126. SYSADATA symbol record	787
100. INEXIT processing	712	127. SYSADATA symbol cross-reference record	798
101. INEXIT parameters	713	128. SYSADATA nested program record	799
102. LIBEXIT processing	713	129. SYSADATA library record	800
103. LIBEXIT processing with nonnested COPY statements	714	130. SYSADATA statistics record	800
104. LIBEXIT processing with nested COPY statements	715	131. SYSADATA EVENTS TIMESTAMP record layout	801
105. LIBEXIT parameters	715	132. SYSADATA EVENTS PROCESSOR record layout	801
		133. SYSADATA EVENTS FILE END record layout	802
		134. SYSADATA EVENTS PROGRAM record layout	802
		135. SYSADATA EVENTS FILE ID record layout	802
		136. SYSADATA EVENTS ERROR record layout	803

Preface

About this information

This information is for COBOL programmers and system programmers. It helps you understand how to use Enterprise COBOL for z/OS[®] to compile COBOL programs. It also describes the operating system features that you might need to optimize program performance or handle errors.

For information about COBOL language, and for references needed to write a program for an IBM[®] COBOL compiler, see the *Enterprise COBOL Language Reference*.

Important: Enterprise COBOL for z/OS is referred to as Enterprise COBOL throughout this information.

How this information will help you

This information will help you write and compile Enterprise COBOL programs. It will also help you define object-oriented classes and methods, invoke methods, and refer to objects in your programs.

This information assumes experience in developing application programs and some knowledge of COBOL. It focuses on using Enterprise COBOL to meet your programming objectives and not on the definition of the COBOL language. For complete information about COBOL syntax, see the *IBM Enterprise COBOL Language Reference*.

For information about migrating programs to Enterprise COBOL, see the *IBM Enterprise COBOL Migration Guide*.

IBM z/OS Language Environment[®] provides the runtime environment and runtime services that are required to run Enterprise COBOL programs. You can find information about link-editing and running programs in the *IBM z/OS Language Environment Programming Guide* and *IBM z/OS Language Environment Programming Reference*.

For a comparison of commonly used Enterprise COBOL and Language Environment terms, see “Comparison of commonly used terms” on page xvi.

Abbreviated terms

Certain terms are used in a shortened form in this information. Abbreviations for the product names used most frequently are listed alphabetically in the following table.

Term used	Long form
CICS [®]	CICS Transaction Server
Enterprise COBOL	IBM Enterprise COBOL for z/OS
Language Environment	IBM z/OS Language Environment
MVS [™]	MVS/ESA
z/OS UNIX	z/OS UNIX System Services

In addition to these abbreviated terms, the term "85 COBOL Standard" is used to refer to the combination of the following standards:

- ISO 1989:1985, Programming languages - COBOL
- ISO/IEC 1989/AMD1:1992, Programming languages - COBOL: Intrinsic function module
- ISO/IEC 1989/AMD2:1994, Programming languages - Correction and clarification amendment for COBOL
- ANSI INCITS 23-1985, Programming Languages - COBOL
- ANSI INCITS 23a-1989, Programming Languages - Intrinsic Function Module for COBOL
- ANSI INCITS 23b-1993, Programming Language - Correction Amendment for COBOL

The ISO standards are identical to the American National standards.

Other terms, if not commonly understood, are shown in *italics* the first time that they appear, and are listed in the glossary.

Comparison of commonly used terms

To better understand the terms used throughout the IBM z/OS Language Environment and IBM Enterprise COBOL for z/OS information, and to understand which terms are meant to be equivalent, see the following table.

Language Environment term	Enterprise COBOL equivalent
Aggregate	Group item
Array	A table created using the OCCURS clause
Array element	Table element
Enclave	Run unit
External data	WORKING-STORAGE data defined using the EXTERNAL clause
Local data	Any non-EXTERNAL data item
Pass parameters directly, by value	BY VALUE
Pass parameters indirectly, by reference	BY REFERENCE
Pass parameters indirectly, by value	BY CONTENT
Routine	Program
Scalar	Elementary item

How to read syntax diagrams

Use the following description to read the syntax diagrams in this information.

- Read the syntax diagrams from left to right, from top to bottom, following the path of the line.

The >>--- symbol indicates the beginning of a syntax diagram.

The ---> symbol indicates that the syntax diagram is continued on the next line.

The >--- symbol indicates that the syntax diagram is continued from the previous line.

The --->< symbol indicates the end of a syntax diagram.

Diagrams of syntactical units other than complete statements start with the >--- symbol and end with the ---> symbol.

- Required items appear on the horizontal line (the main path):

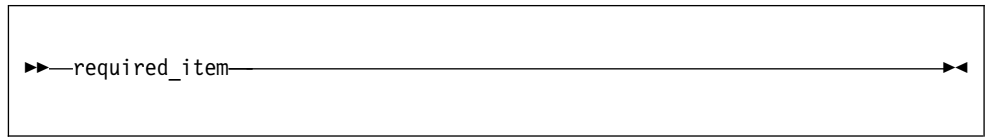

- Optional items appear below the main path:

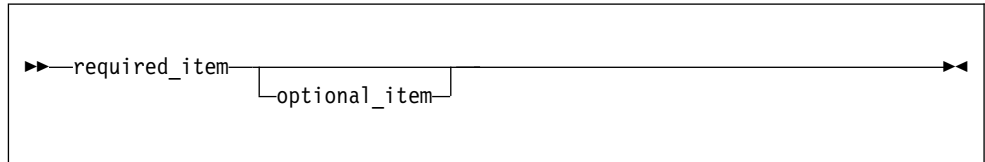

- If you can choose from two or more items, they appear vertically, in a stack. If you must choose one of the items, one item of the stack appears on the main path:

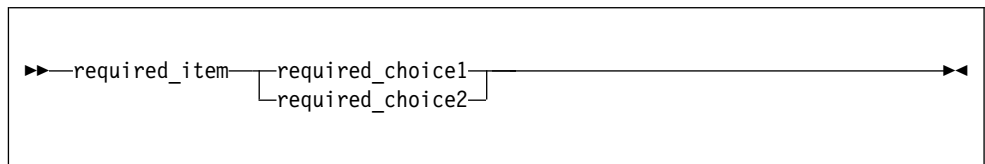

If choosing one of the items is optional, the entire stack appears below the main path:

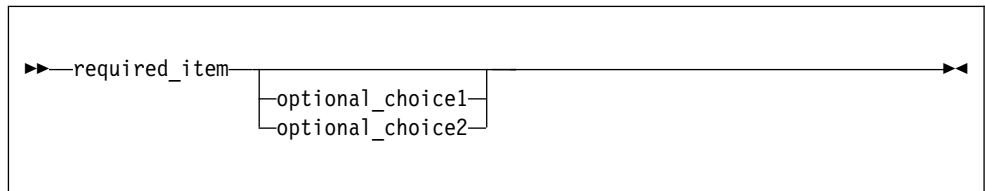

If one of the items is the default, it appears above the main path and the remaining choices are shown below:

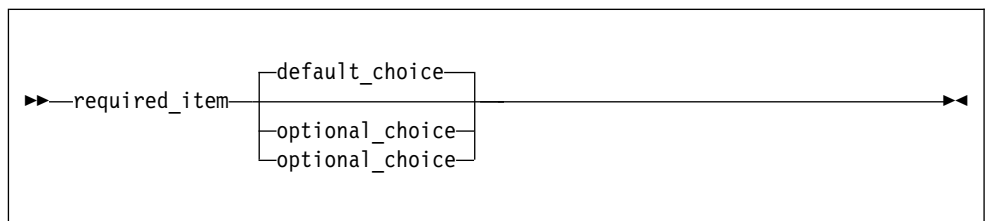

- An arrow returning to the left, above the main line, indicates an item that can be repeated:

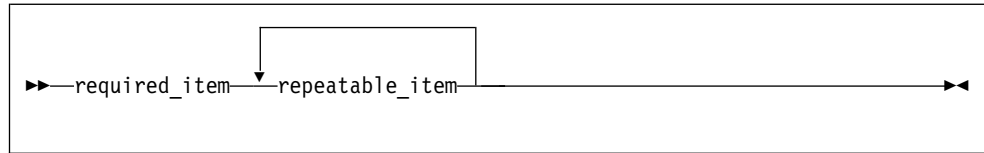

If the repeat arrow contains a comma, you must separate repeated items with a comma:

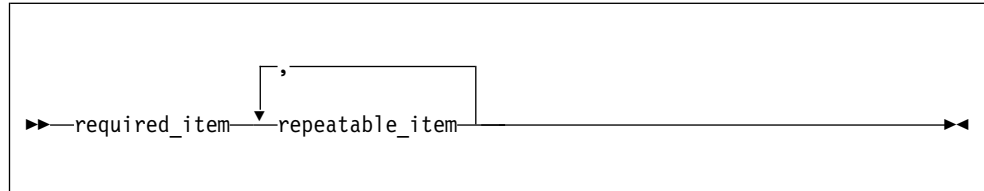

- Keywords appear in uppercase (for example, FROM). They must be spelled exactly as shown. Variables appear in lowercase italics (for example, *column-name*). They represent user-supplied names or values.
- If punctuation marks, parentheses, arithmetic operators, or other such symbols are shown, you must enter them as part of the syntax.

How examples are shown

This information shows numerous examples of sample COBOL statements, program fragments, and small programs to illustrate the coding techniques being described. The examples of program code are written in lowercase, uppercase, or mixed case to demonstrate that you can write your programs in any of these ways.

To more clearly separate some examples from the explanatory text, they are presented in a monospace font.

COBOL keywords and compiler options that appear in text are generally shown in SMALL UPPERCASE. Other terms such as program variable names are sometimes shown in *an italic font* for clarity.

Additional documentation and support

IBM Enterprise COBOL for z/OS provides Portable Document Format (PDF) versions of the entire library for this version and for previous versions on the product site at www.ibm.com/software/awdtools/cobol/zos/library/.

Support information is also available on the product site at http://www.ibm.com/support/entry/portal/Overview/Software/Rational/Enterprise_COBOL_for_z~OS.

Summary of changes

| This section lists the major changes that have been made to this document for
 | Enterprise COBOL Version 5 Release 2 and Version 5 Release 2 with PTFs installed.
 | The latest technical changes are marked within >| and |< in the HTML version, or
 | marked by vertical bars (|) in the left margin in the PDF version.

Version 5 Release 2 with PTFs installed

New, changed, and removed compiler options

- The following compiler options are new:
 - PI40822: ZONECHECK (“ZONECHECK” on page 375)
 - PI69197: INITCHECK (“INITCHECK” on page 331)
 - PI81006: NUMCHECK (“NUMCHECK” on page 341)
 - PI85868: VSAMOPENFS (“VSAMOPENFS” on page 372)
- The following compiler options are modified:
 - PI40853: ZONEDATA: New suboption of NOPFD is added to the ZONEDATA compiler option. ZONEDATA(NOPFD) lets the compiler generate code that performs comparisons of zoned decimal data in the same manner as COBOL V4 does when using NUMPROC(NOPFD|PFD) with COBOL V4. (“ZONEDATA” on page 377)
 - PI53044: SSRANGE: New suboptions ZLEN and NOZLEN are added to the SSRANGE compiler option to control how the compiler checks reference modification lengths. (“SSRANGE” on page 361)
 - PI86343: SSRANGE: New suboptions MSG and ABD are added to the SSRANGE compiler option to control how the compiler checks reference modification lengths. (“SSRANGE” on page 361)
 - PI90458: ZONEDATA: The ZONEDATA option is updated to affect the behaviour of MOVE statements, comparisons, and computations for USAGE DISPLAY or PACKED-DECIMAL data items that could contain invalid digits, an invalid sign code, or invalid zone bits (“ZONEDATA” on page 377).
 - PI97835: NUMCHECK(PAC): For packed decimal (COMP-3) data items that have an even number of digits, the unused bits are checked for zeros. (“NUMCHECK” on page 341)
 - PH01241: NUMCHECK(ZON): New suboptions ALPHNUM | NOALPHNUM are added to the NUMCHECK(ZON) option to control whether the compiler will generate code for an implicit numeric class test for zoned decimal data items that are being compared with an alphanumeric data item, alphanumeric literal or alphanumeric figurative constant. (“NUMCHECK” on page 341)
- The following compiler option is removed:
 - PI81006: ZONECHECK is deprecated but is tolerated for compatibility, and it is replaced by NUMCHECK(ZON). (“ZONECHECK” on page 375)

Version 5 Release 2

- Several changes are made to compiler options:
 - The following compiler options are new:
 - COPYRIGHT | NOCOPYRIGHT (“COPYRIGHT” on page 316)
 - QUALIFY(COMPAT|EXTEND) (“QUALIFY” on page 351)
 - RULES | NORULES (“RULES” on page 354)
 - SERVICE | NOSERVICE (“SERVICE” on page 356)
 - SQLIMS | NOSQLIMS (“SQLIMS” on page 360)
 - VLR(COMPAT | STANDARD) (“VLR” on page 371)
 - XMLPARSE(XMLSS | COMPAT) (“XMLPARSE” on page 373)
 - ZONEDATA(PFD | MIG) (“ZONEDATA” on page 377)
 - The following compiler options are modified:
 - ARCH: ARCH(6) is no longer accepted. A new higher level of ARCH(11) is accepted, and ARCH(7) is the default (“ARCH” on page 307).

- | - MAP: New suboptions of HEX and DEC are added to the MAP compiler option
- | to control whether hexadecimal or decimal offsets are shown for MAP output
- | in the compiler listing (“MAP” on page 335).
- |
- | - The following compiler option is removed:
- |
- | - SIZE
- |
- | • XML PARSE COMPAT support is restored. You can specify the
- | XMLPARSE(XMLSS|COMPAT) compiler option to choose between parsing with the
- | z/OS XML System Services parser, or with the compatibility-mode COBOL XML
- | parser from the COBOL library. It can ease your migration to the Enterprise
- | COBOL V5 compiler.
- |
- | • A new format of the SORT statement, the table SORT statement, arranges table
- | elements in a user-specified sequence. It is part of the 2002 COBOL Standard.
- |
- | • A new section is added to describe accessing VSAM data sets with the extended
- | addressability attribute (“Extended addressability support” on page 211).
- |
- | • A new keyword VOLATILE is added to the format 1 data description entry. The
- | VOLATILE clause indicates that a data item's value can be modified or referenced
- | in ways that the compiler cannot detect, such as by a Language Environment
- | (LE) condition handler routine or by some other asynchronous process or thread.
- | Thus, optimization is restricted for the data item.
- |
- | • Enhancements are made to the XML GENERATE statement:
- |
- | - The WHEN phrase of the XML GENERATE statement can be omitted to
- | allow unconditional suppression of an item when generating XML output. If
- | the WHEN phrase is omitted, that item can be a group data item.
- |
- | - A new keyword CONTENT is added to the generic-suppression-phrase to
- | limit suppression to only TYPE IS CONTENT items.

How to send your comments

Your feedback is important in helping us to provide accurate, high-quality information. If you have comments about this information or any other Enterprise COBOL documentation, contact us in one of these ways:

- Use the Online Readers' Comments Form at www.ibm.com/software/awdtools/rcf/.
- Send your comments to the following address: compinfo@cn.ibm.com.

Be sure to include the name of the document, the publication number, the version of Enterprise COBOL, and, if applicable, the specific location (for example, the page number or section heading) of the text that you are commenting on.

When you send information to IBM, you grant IBM a nonexclusive right to use or distribute the information in any way that IBM believes appropriate without incurring any obligation to you.

Accessibility

Accessibility features help users who have a disability, such as restricted mobility or limited vision, to use information technology products successfully. The accessibility features in z/OS provide accessibility for Enterprise COBOL.

The major accessibility features in z/OS are:

- Interfaces that are commonly used by screen readers and screen-magnifier software
- Keyboard-only navigation

- Ability to customize display attributes such as color, contrast, and font size

Interface information

Assistive technology products work with the user interfaces that are found in z/OS. For specific guidance information, see the documentation for the assistive technology product that you use to access z/OS interfaces.

Keyboard navigation

Users can access z/OS user interfaces by using TSO/E or ISPF. For information about accessing TSO/E or ISPF interfaces, see the following publications:

- *z/OS TSO/E Primer*
- *z/OS TSO/E User's Guide*
- *z/OS ISPF User's Guide Volume I*

These guides describe how to use TSO/E and ISPF, including the use of keyboard shortcuts or function keys (PF keys). Each guide includes the default settings for the PF keys and explains how to modify their functions.

Accessibility of this information

The English-language XHTML format of this information that will be provided in the IBM Knowledge Center at www.ibm.com/support/knowledgecenter/en/SS6SG3_5.2.0/welcome.html is accessible to visually impaired individuals who use a screen reader.

To enable your screen reader to accurately read syntax diagrams, source code examples, and text that contains the period or comma PICTURE symbols, you must set the screen reader to speak all punctuation.

IBM and accessibility

See the IBM Human Ability and Accessibility Center at www.ibm.com/able for more information about the commitment that IBM has to accessibility.

Part 1. Coding your program

Chapter 1. Structuring your program

COBOL programs consist of four divisions: IDENTIFICATION DIVISION, ENVIRONMENT DIVISION, DATA DIVISION, and PROCEDURE DIVISION. Each division has a specific logical function.

To define a program, only the IDENTIFICATION DIVISION is required.

To define a COBOL class or method, you need to define some divisions differently than you do for a program.

RELATED TASKS

“Identifying a program”

“Describing the computing environment” on page 5

“Describing the data” on page 11

“Processing the data” on page 17

“Defining a class” on page 592

“Defining a class instance method” on page 597

“Structuring OO applications” on page 630

Identifying a program

Use the IDENTIFICATION DIVISION to name a program and optionally provide other identifying information.

You can use the optional AUTHOR, INSTALLATION, DATE-WRITTEN, and DATE-COMPILED paragraphs for descriptive information about a program. The data you enter in the DATE-COMPILED paragraph is replaced with the latest compilation date.

IDENTIFICATION DIVISION.

```
Program-ID.      Helloprog.  
Author.         A. Programmer.  
Installation.   Computing Laboratories.  
Date-Written.   07/30/2009.  
Date-Compiled.  03/30/2013.
```

Use the PROGRAM-ID paragraph to name your program. The program-name that you assign is used in these ways:

- Other programs use that name to call your program.
- The name appears in the header on each page, except the first, of the program listing that is generated when you compile the program.
- If you use the NAME compiler option, the name is placed on the NAME binder (linkage-editor) control statement to identify the object module that the compilation creates.

Tip: Do not use program-names that start with prefixes used by IBM products. If you use program-names that start with any of the following prefixes, your CALL statements might resolve to IBM library or compiler routines rather than to your intended program:

- AFB
- AFH
- CBC
- CEE

- CEH
- CEL
- CEQ
- CEU
- DFH
- DSN
- EDC
- FOR
- IBM
- IFY
- IGY
- IGZ
- ILB

Tip: If a program-name is case sensitive, avoid mismatches with the name that the compiler is looking for. Verify that the appropriate setting of the PGMNAME compiler option is in effect.

RELATED TASKS

- “Changing the header of a source listing” on page 5
- “Identifying a program as recursive”
- “Marking a program as callable by containing programs”
- “Setting a program to an initial state” on page 5

RELATED REFERENCES

- Compiler limits (*Enterprise COBOL Language Reference*)
- Conventions for program-names (*Enterprise COBOL Language Reference*)

Identifying a program as recursive

Code the RECURSIVE attribute on the PROGRAM-ID clause to specify that a program can be recursively reentered while a previous invocation is still active.

You can code RECURSIVE only on the outermost program of a compilation unit. Neither nested subprograms nor programs that contain nested subprograms can be recursive. You must code RECURSIVE for programs that you compile with the THREAD option.

RELATED TASKS

- “Sharing data in recursive or multithreaded programs” on page 17
- “Making recursive calls” on page 487

Marking a program as callable by containing programs

Use the COMMON attribute in the PROGRAM-ID paragraph to specify that a program can be called by the containing program or by any program in the containing program. The COMMON program cannot be called by any program contained in itself.

Only contained programs can have the COMMON attribute.

RELATED CONCEPTS

- “Nested programs” on page 484

Setting a program to an initial state

Use the INITIAL clause in the PROGRAM-ID paragraph to specify that whenever a program is called, that program and any nested programs that it contains are to be placed in their initial state.

When a program is set to its initial state:

- Data items that have VALUE clauses are set to the specified values.
- Changed GO TO statements and PERFORM statements are in their initial states.
- Non-EXTERNAL files are closed.

RELATED TASKS

“Ending and reentering main programs or subprograms” on page 474

“Making static calls” on page 476

“Making dynamic calls” on page 477

Changing the header of a source listing

The header on the first page of a source listing contains the identification of the compiler and the current release level, the date and time of compilation, and the page number.

The following example shows these five elements:

```
PP 5655-W32 IBM Enterprise COBOL for z/OS 5.1.0      Date 03/30/2013 Time 15:05:19 Page 1
```

The header indicates the compilation platform. You can customize the header on succeeding pages of the listing by using the compiler-directing TITLE statement.

RELATED REFERENCES

TITLE statement (*Enterprise COBOL Language Reference*)

Describing the computing environment

In the ENVIRONMENT DIVISION of a program, you describe the aspects of the program that depend on the computing environment.

Use the CONFIGURATION SECTION to specify the following items:

- Computer for compiling the program (in the SOURCE-COMPUTER paragraph)
- Computer for running the program (in the OBJECT-COMPUTER paragraph)
- Special items such as the currency sign and symbolic characters (in the SPECIAL-NAMES paragraph)
- User-defined classes (in the REPOSITORY paragraph)

Use the FILE-CONTROL and I-O-CONTROL paragraphs of the INPUT-OUTPUT SECTION to:

- Identify and describe the characteristics of the files in the program.
- Associate your files with the external QSAM, VSAM, or z/OS UNIX file system data sets where they physically reside.

The terms *file* in COBOL terminology and *data set* in operating-system terminology have essentially the same meaning and are used interchangeably in this information.

For Customer Information Control System (CICS) and online Information Management System (IMS) message processing programs (MPP), code only the ENVIRONMENT DIVISION header and, optionally, the CONFIGURATION SECTION. Do

not code file definitions in your COBOL programs that will run under CICS. IMS allows COBOL definition of files only for batch programs.

- Provide information to control efficient transmission of the data records between your program and the external medium.

“Example: FILE-CONTROL entries”

RELATED TASKS

- “Specifying the collating sequence”
- “Defining symbolic characters” on page 8
- “Defining a user-defined class” on page 8
- “Defining files to the operating system” on page 8

RELATED REFERENCES

Sections and paragraphs (*Enterprise COBOL Language Reference*)

Example: FILE-CONTROL entries

The following table shows example FILE-CONTROL entries for a QSAM sequential file, a VSAM indexed file, and a line-sequential file.

Table 1. FILE-CONTROL entries

QSAM file	VSAM file	Line-sequential file
SELECT PRINTFILE ¹ ASSIGN TO UPDPRINT ² ORGANIZATION IS SEQUENTIAL ³ ACCESS IS SEQUENTIAL. ⁴	SELECT COMMUTER-FILE ¹ ASSIGN TO COMMUTER ² ORGANIZATION IS INDEXED ³ ACCESS IS RANDOM ⁴ RECORD KEY IS COMMUTER-KEY ⁵ FILE STATUS IS ⁵ COMMUTER-FILE-STATUS COMMUTER-VSAM-STATUS.	SELECT PRINTFILE ¹ ASSIGN TO UPDPRINT ² ORGANIZATION IS LINE SEQUENTIAL ³ ACCESS IS SEQUENTIAL. ⁴
<ol style="list-style-type: none"> 1. The SELECT clause chooses a file in the COBOL program to be associated with an external data set. 2. The ASSIGN clause associates the program's name for the file with the external name for the actual data file. You can define the external name with a DD statement or an environment variable. 3. The ORGANIZATION clause describes the file's organization. For QSAM files, the ORGANIZATION clause is optional. 4. The ACCESS MODE clause defines the manner in which the records are made available for processing: sequential, random, or dynamic. For QSAM and line-sequential files, the ACCESS MODE clause is optional. These files always have sequential organization. 5. For VSAM files, you might have additional statements in the FILE-CONTROL paragraph depending on the type of VSAM file you use. 		

RELATED TASKS

- Chapter 9, “Processing QSAM files,” on page 159
- Chapter 10, “Processing VSAM files,” on page 185
- Chapter 11, “Processing line-sequential files,” on page 213
- “Describing the computing environment” on page 5

Specifying the collating sequence

You can use the PROGRAM COLLATING SEQUENCE clause and the ALPHABET clause of the SPECIAL-NAMES paragraph to establish the collating sequence that is used in several operations on alphanumeric items.

These clauses specify the collating sequence for the following operations on alphanumeric items:

- Comparisons explicitly specified in relation conditions and condition-name conditions
- HIGH-VALUE and LOW-VALUE settings
- SEARCH ALL
- SORT and MERGE unless overridden by a COLLATING SEQUENCE phrase in the SORT or MERGE statement

“Example: specifying the collating sequence”

The sequence that you use can be based on one of these alphabets:

- EBCDIC: references the collating sequence associated with the EBCDIC character set
- NATIVE: references the same collating sequence as EBCDIC
- STANDARD-1: references the collating sequence associated with the ASCII character set defined by *ANSI INCITS X3.4, Coded Character Sets - 7-bit American National Standard Code for Information Interchange (7-bit ASCII)*
- STANDARD-2: references the collating sequence associated with the character set defined by *ISO/IEC 646 -- Information technology -- ISO 7-bit coded character set for information interchange, International Reference Version*
- An alteration of the EBCDIC sequence that you define in the SPECIAL-NAMES paragraph

The PROGRAM COLLATING SEQUENCE clause does not affect comparisons that involve national or DBCS operands.

RELATED TASKS

“Choosing alternate collating sequences” on page 229

“Comparing national (UTF-16) data” on page 147

Example: specifying the collating sequence

The following example shows the ENVIRONMENT DIVISION coding that you can use to specify a collating sequence in which uppercase and lowercase letters are similarly handled in comparisons and in sorting and merging.

When you change the EBCDIC sequence in the SPECIAL-NAMES paragraph, the overall collating sequence is affected, not just the collating sequence of the characters that are included in the SPECIAL-NAMES paragraph.

```
IDENTIFICATION DIVISION.
. . .
ENVIRONMENT DIVISION.
CONFIGURATION SECTION.
Source-Computer. IBM-390.
Object-Computer. IBM-390
    Program Collating Sequence Special-Sequence.
Special-Names.
    Alphabet Special-Sequence Is
        "A" Also "a"
        "B" Also "b"
        "C" Also "c"
        "D" Also "d"
        "E" Also "e"
        "F" Also "f"
        "G" Also "g"
        "H" Also "h"
        "I" Also "i"
        "J" Also "j"
        "K" Also "k"
```

```

"L" Also "l"
"M" Also "m"
"N" Also "n"
"O" Also "o"
"P" Also "p"
"Q" Also "q"
"R" Also "r"
"S" Also "s"
"T" Also "t"
"U" Also "u"
"V" Also "v"
"W" Also "w"
"X" Also "x"
"Y" Also "y"
"Z" Also "z".

```

RELATED TASKS

“Specifying the collating sequence” on page 6

Defining symbolic characters

Use the SYMBOLIC CHARACTERS clause to give symbolic names to any character of the specified alphabet. Use ordinal position to identify the character, where position 1 corresponds to character X'00'.

For example, to give a name to the backspace character (X'16' in the EBCDIC alphabet), code:

```
SYMBOLIC CHARACTERS BACKSPACE IS 23
```

Defining a user-defined class

Use the CLASS clause to give a name to a set of characters that you list in the clause.

For example, name the set of digits by coding the following clause:

```
CLASS DIGIT IS "0" THROUGH "9"
```

You can reference the class-name only in a class condition. (This user-defined class is not the same as an object-oriented class.)

Defining files to the operating system

For all files that you process in your COBOL program, you need to define the files to the operating system with an appropriate system data definition.

Depending on the operating system, this system data definition can take any of the following forms:

- DD statement for MVS JCL.
- ALLOCATE command under TSO.
- Environment variable for z/OS or z/OS UNIX. The contents can define either an MVS data set or a file in the z/OS UNIX file system.

The following examples show the relationship of a FILE-CONTROL entry to the system data definition and to the FD entry in the FILE SECTION:

- JCL DD statement:

```

(1)
//OUTFILE DD DSNAME=MY.OUT171,UNIT=SYSDA,SPACE=(TRK,(50,5))
/*

```

- Environment variable (export command):

(1)

```
export OUTFILE=DSN(MY.OUT171),UNIT(SYSDA),SPACE(TRK,(50,5))
```

- COBOL code:

```
ENVIRONMENT DIVISION.
INPUT-OUTPUT SECTION.
FILE-CONTROL.
    SELECT CARPOOL
        ASSIGN TO OUTFILE (1)
        ORGANIZATION IS SEQUENTIAL.
```

. . .

```
DATA DIVISION.
FILE SECTION.
FD CARPOOL (2)
    LABEL RECORD STANDARD
    BLOCK CONTAINS 0 CHARACTERS
    RECORD CONTAINS 80 CHARACTERS
```

- (1) The *assignment-name* in the ASSIGN clause points to the *ddname* OUTFILE in the DD statement or the environment variable OUTFILE in the export command:
 - //OUTFILE DD DSN=OUT171 . . . , or
 - export OUTFILE= . . .
- (2) When you specify a file *file-name* in a FILE-CONTROL entry, you must describe the file in an FD entry:

```
SELECT CARPOOL
. . .
FD CARPOOL
```

RELATED TASKS

“Optimizing buffer and device space” on page 10

RELATED REFERENCES

“FILE SECTION entries” on page 12

FILE SECTION (*Enterprise COBOL Language Reference*)

Varying the input or output file at run time

The *file-name* that you code in a SELECT clause is used as a constant throughout your COBOL program, but you can associate the name of that file with a different system file at run time.

Changing a file-name within a COBOL program would require changing the input statements and output statements and recompiling the program. Alternatively, you can change the DSN value in the DD statement or the DSN or PATH value in the export command to use a different file at run time.

Environment variable values that are in effect at the time of the OPEN statement are used for associating COBOL file-names to the system file-names (including any path specifications).

The name that you use in the *assignment-name* of the ASSIGN clause must be the same as the *ddname* in the DD statement or the environment variable in the export command.

The *file-name* that you use in the SELECT clause (such as SELECT MASTER) must be the same as in the FD *file-name* entry.

Two files should not use the same ddname or environment variable name in their SELECT clauses; otherwise, results could be unpredictable. For example, if DISPLAY output is directed to SYSOUT, do not use SYSOUT as the ddname or environment variable name in the SELECT clause for a file.

Example: using different input files:

This example shows that you use the same COBOL program to access different files by coding a DD statement or an export command before the programs runs.

Consider a COBOL program that contains the following SELECT clause:

```
SELECT MASTER ASSIGN TO DA-3330-S-MASTERA
```

Assume the three possible input files are MASTER1, MASTER2, and MASTER3. Before running the program, code one of the following DD statements in the job step that calls for program execution, or issue one of the following export commands from the same shell from which you run the program:

```
//MASTERA DD DSNAME=MY.MASTER1,. . .  
export MASTERA=DSN(MY.MASTER1),. . .
```

```
//MASTERA DD DSNAME=MY.MASTER2,. . .  
export MASTERA=DSN(MY.MASTER2),. . .
```

```
//MASTERA DD DSNAME=MY.MASTER3,. . .  
export MASTERA=DSN(MY.MASTER3),. . .
```

Any reference in the program to MASTER will therefore be a reference to the file that is currently assigned to the ddname or environment-variable name MASTERA.

Notice that in this example, you cannot use the PATH(*path*) form of the export command to reference a line-sequential file in the z/OS UNIX file system, because you cannot specify an organization field (S- or AS-) with a line-sequential file.

Optimizing buffer and device space

Use the APPLY WRITE-ONLY clause to make optimum use of buffer and device space when you create a sequential file with blocked variable-length records.

With APPLY WRITE-ONLY specified, a buffer is truncated only when the next record does not fit in the unused portion of the buffer. Without APPLY WRITE-ONLY specified, a buffer is truncated when it does not have enough space for a maximum-size record.

The APPLY WRITE-ONLY clause has meaning only for sequential files that have variable-length records and are blocked.

The AWO compiler option applies an implicit APPLY WRITE-ONLY clause to all eligible files. The NOAWO compiler option has no effect on files that have the APPLY WRITE-ONLY clause specified. The APPLY WRITE-ONLY clause takes precedence over the NOAWO compiler option.

The APPLY-WRITE ONLY clause can cause input files to use a record area rather than process the data in the buffer. This use might affect the processing of both input files and output files.

RELATED REFERENCES
“AWO” on page 310

Describing the data

Define the characteristics of your data, and group your data definitions into one or more of the sections in the DATA DIVISION.

You can use these sections for defining the following types of data:

- Data used in input-output operations: FILE SECTION
- Data developed for internal processing:
 - To have storage be statically allocated and exist for the life of the *run unit*: WORKING-STORAGE SECTION
 - To have storage be allocated each time a program is entered, and deallocated on return from the program: LOCAL-STORAGE SECTION
- Data from another program: LINKAGE SECTION

The Enterprise COBOL compiler limits the maximum size of DATA DIVISION elements. For details, see the related reference about compiler limits below.

RELATED CONCEPTS

“Comparison of WORKING-STORAGE and LOCAL-STORAGE” on page 14

RELATED TASKS

“Using data in input and output operations”

“Using data from another program” on page 16

RELATED REFERENCES

Compiler limits (*Enterprise COBOL Language Reference*)

Using data in input and output operations

Define the data that you use in input and output operations in the FILE SECTION.

Provide the following information about the data:

- Name the input and output files that the program will use. Use the FD entry to give names to the files that the input-output statements in the PROCEDURE DIVISION can refer to.

Data items defined in the FILE SECTION are not available to PROCEDURE DIVISION statements until the file has been successfully opened.

- In the record description that follows the FD entry, describe the fields of the records in the file:
 - You can code a level-01 description of the entire record, and then in the WORKING-STORAGE SECTION code a working copy that describes the fields of the record in more detail. Use the READ INTO statement to bring the records into WORKING-STORAGE. Processing occurs on the copy of data in WORKING-STORAGE. A WRITE FROM statement writes processed data into the record area defined in the FILE SECTION.
 - The record-name established is the object of WRITE and REWRITE statements.
 - For QSAM files only, you can set the record format in the RECORDING MODE clause. If you omit the RECORDING MODE clause, the compiler determines the record format based on the RECORD clause and on the level-01 record descriptions.
 - For QSAM files, you can set a blocking factor for the file in the BLOCK CONTAINS clause. If you omit the BLOCK CONTAINS clause, the file defaults to

unblocked. However, you can override this with z/OS data management facilities (including a DD file job-control statement).

- For line-sequential files, you can set a blocking factor for the file in the BLOCK CONTAINS clause. When you code BLOCK CONTAINS 1 RECORDS, or BLOCK CONTAINS *n* CHARACTERS, where *n* is the length of one logical record in bytes, WRITE statements result in the record being transferred immediately to the file rather than being buffered. This technique is useful when you want each record written immediately, such as to an error log.

Programs in the same run unit can share, or have access to, common files. The method for doing this depends on whether the programs are part of a nested (contained) structure or are separately compiled (including programs compiled as part of a batch sequence).

You can use the EXTERNAL clause for separately compiled programs. A file that is defined as EXTERNAL can be referenced by any program in the run unit that describes the file.

You can use the GLOBAL clause for programs in a nested, or contained, structure. If a program contains another program (directly or indirectly), both programs can access a common file by referencing a GLOBAL file-name.

RELATED CONCEPTS

“Nested programs” on page 484

RELATED TASKS

“Sharing files between programs (external files)” on page 501

RELATED REFERENCES

“FILE SECTION entries”

FILE SECTION entries

The entries that you can use in the FILE SECTION are summarized in the table below.

Table 2. FILE SECTION entries

Clause	To define	Notes
FD	The <i>file-name</i> to be referred to in PROCEDURE DIVISION input-output statements (OPEN, CLOSE, READ, also START and DELETE for VSAM)	Must match <i>file-name</i> in the SELECT clause. <i>file-name</i> is associated with a <i>ddname</i> through the <i>assignment-name</i> .

Table 2. FILE SECTION entries (continued)

Clause	To define	Notes
BLOCK CONTAINS	Size of physical records	<p>If the CHARACTERS phrase is specified, size indicates the number of bytes in a record regardless of the USAGE of the data items in the record.</p> <p>QSAM: If provided, must match information on JCL or data-set label. If specified as BLOCK CONTAINS 0, or not provided, the system determines the optimal block size for you.</p> <p>Line sequential: Can be specified to control buffering for WRITE statements.</p> <p>VSAM: Syntax-checked, but has no effect on execution.</p>
RECORD CONTAINS <i>n</i>	Size of logical records (fixed length)	Integer size indicates the number of bytes in a record regardless of the USAGE of the data items in the record. If the clause is provided, it must match information on JCL or data-set label. If <i>n</i> is equal to 0, LRECL must be coded on JCL or data-set label.
RECORD IS VARYING	Size of logical records (variable length)	Integer size or sizes, if specified, indicate the number of bytes in a record regardless of the USAGE of the data items in the record. If the clause is provided, it must match information on JCL or data-set label; compiler checks that record descriptions match.
RECORD CONTAINS <i>n</i> TO <i>m</i>	Size of logical records (variable length)	The integer sizes indicate the number of bytes in a record regardless of the USAGE of the data items in the record. If the clause is provided, it must match information on JCL or data-set label; compiler checks that record descriptions match.
LABEL RECORDS	Labels for QSAM files	VSAM: Handled as comments
STANDARD	Labels exist	QSAM: Handled as comments
OMITTED	Labels do not exist	QSAM: Handled as comments
<i>data-name</i>	Labels defined by the user	QSAM: Allowed for (optional) tape or disk
VALUE OF	An item in the label records associated with file	Comments only
DATA RECORDS	Names of records associated with file	Comments only
LINAGE	Depth of logical page	QSAM only

Table 2. FILE SECTION entries (continued)

Clause	To define	Notes
CODE-SET	ASCII or EBCDIC files	QSAM only. When an ASCII file is identified with the CODE-SET clause, the corresponding DD statement might need to have DCB=(OPTCD=Q. . .) or DCB=(RECFM=D. . .) coded if the file was not created using VS COBOL II, COBOL for OS/390® & VM, or IBM Enterprise COBOL for z/OS.
RECORDING MODE	Physical record description	QSAM only

RELATED REFERENCES

FILE SECTION (*Enterprise COBOL Language Reference*)

Comparison of WORKING-STORAGE and LOCAL-STORAGE

How data items are allocated and initialized varies depending on whether the items are in the WORKING-STORAGE SECTION or LOCAL-STORAGE SECTION.

WORKING-STORAGE for programs is allocated when the run unit is started.

Any data items that have VALUE clauses are initialized to the appropriate value at that time. For the duration of the run unit, WORKING-STORAGE items persist in their last-used state. Exceptions are:

- A program with INITIAL specified in the PROGRAM-ID paragraph
In this case, WORKING-STORAGE data items are reinitialized each time that the program is entered.
- A subprogram that is dynamically called and then canceled
In this case, WORKING-STORAGE data items are reinitialized on the first reentry into the program following the CANCEL.

WORKING-STORAGE is deallocated at the termination of the run unit.

See the related tasks for information about WORKING-STORAGE in COBOL class definitions.

A separate copy of LOCAL-STORAGE data is allocated for each call of a program or invocation of a method, and is freed on return from the program or method. If you specify a VALUE clause for a LOCAL-STORAGE item, the item is initialized to that value on each call or invocation. If a VALUE clause is not specified, the initial value of the item is undefined.

Threading: Each invocation of a program that runs simultaneously on multiple threads shares access to a single copy of WORKING-STORAGE data. Each invocation has a separate copy of LOCAL-STORAGE data.

“Example: storage sections” on page 15

RELATED TASKS

“Ending and reentering main programs or subprograms” on page 474

Chapter 27, "Preparing COBOL programs for multithreading," on page 517
 "WORKING-STORAGE SECTION for defining class instance data" on page 596

RELATED REFERENCES

WORKING-STORAGE SECTION (*Enterprise COBOL Language Reference*)

LOCAL-STORAGE SECTION (*Enterprise COBOL Language Reference*)

Example: storage sections

The following example is a recursive program that uses both WORKING-STORAGE and LOCAL-STORAGE.

```
CBL pgmn(1u)
*****
* Recursive Program - Factorials
*****
IDENTIFICATION DIVISION.
Program-Id. factorial recursive.
ENVIRONMENT DIVISION.
DATA DIVISION.
WORKING-STORAGE SECTION.
01 numb pic 9(4) value 5.
01 fact pic 9(8) value 0.
LOCAL-STORAGE SECTION.
01 num pic 9(4).
PROCEDURE DIVISION.
    move numb to num.

    if numb = 0
        move 1 to fact
    else
        subtract 1 from numb
        call 'factorial'
        multiply num by fact
    end-if.

    display num '! = ' fact.
    goback.
End Program factorial.
```

The program produces the following output:

```
0000! = 00000001
0001! = 00000001
0002! = 00000002
0003! = 00000006
0004! = 00000024
0005! = 00000120
```

The following tables show the changing values of the data items in LOCAL-STORAGE and WORKING-STORAGE in the successive recursive calls of the program, and in the ensuing gobacks. During the gobacks, fact progressively accumulates the value of 5! (five factorial).

Recursive calls	Value for num in LOCAL-STORAGE	Value for numb in WORKING-STORAGE	Value for fact in WORKING-STORAGE
Main	5	5	0
1	4	4	0
2	3	3	0
3	2	2	0
4	1	1	0
5	0	0	0

Gobacks	Value for num in LOCAL-STORAGE	Value for numb in WORKING-STORAGE	Value for fact in WORKING-STORAGE
5	0	0	1
4	1	0	1
3	2	0	2
2	3	0	6
1	4	0	24
Main	5	0	120

RELATED CONCEPTS

“Comparison of WORKING-STORAGE and LOCAL-STORAGE” on page 14

Using data from another program

How you share data depends on the type of program. You share data differently in programs that are separately compiled than you do for programs that are nested or for programs that are recursive or multithreaded.

RELATED TASKS

“Sharing data in separately compiled programs”

“Sharing data in nested programs”

“Sharing data in recursive or multithreaded programs” on page 17

“Passing data” on page 491

Sharing data in separately compiled programs

Many applications consist of separately compiled programs that call and pass data to one another. Use the LINKAGE SECTION in the called program to describe the data passed from another program.

In the calling program, code a CALL . . . USING or INVOKE . . . USING statement to pass the data.

RELATED TASKS

“Passing data” on page 491

“Coding the LINKAGE SECTION” on page 495

Sharing data in nested programs

Some applications consist of nested programs, that is, programs that are contained in other programs. Level-01 data items can include the GLOBAL attribute. This attribute allows any nested program that includes the declarations to access these data items.

A nested program can also access data items in a sibling program (one at the same nesting level in the same containing program) that is declared with the COMMON attribute.

RELATED CONCEPTS

“Nested programs” on page 484

Sharing data in recursive or multithreaded programs

If your program has the `RECURSIVE` attribute or is compiled with the `THREAD` compiler option, data that is defined in the `LINKAGE SECTION` is not accessible on subsequent invocations of the program.

To address a record in the `LINKAGE SECTION`, use either of these techniques:

- Pass an argument to the program and specify the record in an appropriate position in the `USING` phrase in the program.
- Use the `format-5 SET` statement.

If your program has the `RECURSIVE` attribute or is compiled with the `THREAD` compiler option, the address of the record is valid for a particular instance of the program invocation. The address of the record in another execution instance of the same program must be reestablished for that execution instance. Unpredictable results will occur if you refer to a data item for which the address has not been established.

RELATED CONCEPTS

“Multithreading” on page 518

RELATED TASKS

“Making recursive calls” on page 487

“Processing files with multithreading” on page 520

RELATED REFERENCES

“`THREAD`” on page 366

`SET` statement (*Enterprise COBOL Language Reference*)

Processing the data

In the `PROCEDURE DIVISION` of a program, you code the executable statements that process the data that you defined in the other divisions. The `PROCEDURE DIVISION` contains one or two headers and the logic of your program.

The `PROCEDURE DIVISION` begins with the division header and a procedure-name header. The division header for a program can simply be:

```
PROCEDURE DIVISION.
```

You can code the division header to receive parameters by using the `USING` phrase, or to return a value by using the `RETURNING` phrase.

To receive an argument that was passed by reference (the default) or by content, code the division header for a program in either of these ways:

```
PROCEDURE DIVISION USING dataname  
PROCEDURE DIVISION USING BY REFERENCE dataname
```

Be sure to define *dataname* in the `LINKAGE SECTION` of the `DATA DIVISION`.

To receive a parameter that was passed by value, code the division header for a program as follows:

```
PROCEDURE DIVISION USING BY VALUE dataname
```

To return a value as a result, code the division header as follows:

```
PROCEDURE DIVISION RETURNING dataname2
```

You can also combine USING and RETURNING in a PROCEDURE DIVISION header:
PROCEDURE DIVISION USING *dataname* RETURNING *dataname2*

Be sure to define *dataname* and *dataname2* in the LINKAGE SECTION.

RELATED CONCEPTS

“How logic is divided in the PROCEDURE DIVISION”

RELATED TASKS

“Coding the LINKAGE SECTION” on page 495

“Coding the PROCEDURE DIVISION for passing arguments” on page 496

“Using PROCEDURE DIVISION RETURNING . . .” on page 500

“Eliminating repetitive coding” on page 675

RELATED REFERENCES

The procedure division header (*Enterprise COBOL Language Reference*)

The USING phrase (*Enterprise COBOL Language Reference*)

CALL statement (*Enterprise COBOL Language Reference*)

How logic is divided in the PROCEDURE DIVISION

The PROCEDURE DIVISION of a program is divided into sections and paragraphs, which contain sentences, statements, and phrases.

Section

Logical subdivision of your processing logic.

A section has a section header and is optionally followed by one or more paragraphs.

A section can be the subject of a PERFORM statement. One type of section is for declaratives.

Paragraph

Subdivision of a section, procedure, or program.

A paragraph has a name followed by a period and zero or more sentences.

A paragraph can be the subject of a statement.

Sentence

Series of one or more COBOL statements that ends with a period.

Statement

Performs a defined step of COBOL processing, such as adding two numbers.

A statement is a valid combination of words, and begins with a COBOL verb. Statements are imperative (indicating unconditional action), conditional, or compiler-directing. Using explicit scope terminators instead of periods to show the logical end of a statement is preferred.

Phrase

A subdivision of a statement.

RELATED CONCEPTS

“Compiler-directing statements” on page 20

“Scope terminators” on page 20

“Imperative statements” on page 19

“Conditional statements” on page 19

“Declaratives” on page 21

RELATED REFERENCES

PROCEDURE DIVISION structure (*Enterprise COBOL Language Reference*)

Imperative statements

An imperative statement (such as ADD, MOVE, INVOKE, or CLOSE) indicates an unconditional action to be taken.

You can end an imperative statement with an implicit or explicit scope terminator.

A conditional statement that ends with an explicit scope terminator becomes an imperative statement called a *delimited scope statement*. Only imperative statements (or delimited scope statements) can be nested.

RELATED CONCEPTS

“Conditional statements”

“Scope terminators” on page 20

Conditional statements

A conditional statement is either a simple conditional statement (IF, EVALUATE, SEARCH) or a conditional statement made up of an imperative statement that includes a conditional phrase or option.

You can end a conditional statement with an implicit or explicit scope terminator. If you end a conditional statement explicitly, it becomes a delimited scope statement (which is an imperative statement).

You can use a delimited scope statement in these ways:

- To delimit the range of operation for a COBOL conditional statement and to explicitly show the levels of nesting
For example, use an END-IF phrase instead of a period to end the scope of an IF statement within a nested IF.
- To code a conditional statement where the COBOL syntax calls for an imperative statement

For example, code a conditional statement as the object of an inline PERFORM:

```
PERFORM UNTIL TRANSACTION-EOF
  PERFORM 200-EDIT-UPDATE-TRANSACTION
  IF NO-ERRORS
    PERFORM 300-UPDATE-COMMUTER-RECORD
  ELSE
    PERFORM 400-PRINT-TRANSACTION-ERRORS
  END-IF
  READ UPDATE-TRANSACTION-FILE INTO WS-TRANSACTION-RECORD
  AT END
    SET TRANSACTION-EOF TO TRUE
  END-READ
END-PERFORM
```

An explicit scope terminator is required for the inline PERFORM statement, but it is not valid for the out-of-line PERFORM statement.

For additional program control, you can use the NOT phrase with conditional statements. For example, you can provide instructions to be performed when a particular exception does not occur, such as NOT ON SIZE ERROR. The NOT phrase cannot be used with the ON OVERFLOW phrase of the CALL statement, but it can be used with the ON EXCEPTION phrase.

Do not nest conditional statements. Nested statements must be imperative statements (or delimited scope statements) and must follow the rules for imperative statements.

The following statements are examples of conditional statements if they are coded without scope terminators:

- Arithmetic statement with ON SIZE ERROR
- Data-manipulation statements with ON OVERFLOW
- CALL statements with ON OVERFLOW
- I/O statements with INVALID KEY, AT END, or AT END-OF-PAGE
- RETURN with AT END

RELATED CONCEPTS

“Imperative statements” on page 19

“Scope terminators”

RELATED TASKS

“Selecting program actions” on page 93

RELATED REFERENCES

Conditional statements (*Enterprise COBOL Language Reference*)

Compiler-directing statements

A compiler-directing statement causes the compiler to take specific action about the program structure, COPY processing, listing control, or control flow.

A compiler-directing statement is not part of the program logic.

RELATED REFERENCES

Chapter 18, “Compiler-directing statements,” on page 381

Compiler-directing statements (*Enterprise COBOL Language Reference*)

Scope terminators

A scope terminator ends a verb or statement. Scope terminators can be explicit or implicit.

Explicit scope terminators end a verb without ending a sentence. They consist of END followed by a hyphen and the name of the verb being terminated, such as END-IF. An implicit scope terminator is a period (.) that ends the scope of all previous statements not yet ended.

Each of the two periods in the following program fragment ends an IF statement, making the code equivalent to the code after it that instead uses explicit scope terminators:

```
IF ITEM = "A"
    DISPLAY "THE VALUE OF ITEM IS " ITEM
    ADD 1 TO TOTAL
    MOVE "C" TO ITEM
    DISPLAY "THE VALUE OF ITEM IS NOW " ITEM.
IF ITEM = "B"
    ADD 2 TO TOTAL.
IF ITEM = "A"
    DISPLAY "THE VALUE OF ITEM IS " ITEM
    ADD 1 TO TOTAL
    MOVE "C" TO ITEM
    DISPLAY "THE VALUE OF ITEM IS NOW " ITEM
```

```

END-IF
IF ITEM = "B"
    ADD 2 TO TOTAL
END-IF

```

If you use implicit terminators, the end of statements can be unclear. As a result, you might end statements unintentionally, changing your program's logic. Explicit scope terminators make a program easier to understand and prevent unintentional ending of statements. For example, in the program fragment below, changing the location of the first period in the first implicit scope example changes the meaning of the code:

```

IF ITEM = "A"
    DISPLAY "VALUE OF ITEM IS " ITEM
    ADD 1 TO TOTAL.
    MOVE "C" TO ITEM
    DISPLAY " VALUE OF ITEM IS NOW " ITEM
IF ITEM = "B"
    ADD 2 TO TOTAL.

```

The MOVE statement and the DISPLAY statement after it are performed regardless of the value of ITEM, despite what the indentation indicates, because the first period terminates the IF statement.

For improved program clarity and to avoid unintentional ending of statements, use explicit scope terminators, especially within paragraphs. Use implicit scope terminators only at the end of a paragraph or the end of a program.

Be careful when coding an explicit scope terminator for an imperative statement that is nested within a conditional statement. Ensure that the scope terminator is paired with the statement for which it was intended. In the following example, the scope terminator will be paired with the second READ statement, though the programmer intended it to be paired with the first.

```

READ FILE1
    AT END
        MOVE A TO B
        READ FILE2
END-READ

```

To ensure that the explicit scope terminator is paired with the intended statement, the preceding example can be recoded in this way:

```

READ FILE1
    AT END
        MOVE A TO B
        READ FILE2
    END-READ
END-READ

```

RELATED CONCEPTS

“Conditional statements” on page 19

“Imperative statements” on page 19

Declaratives

Declaratives provide one or more special-purpose sections that are executed when an exception condition occurs.

Start each declarative section with a USE statement that identifies the function of the section. In the procedures, specify the actions to be taken when the condition occurs.

RELATED TASKS

“Finding and handling input-output errors” on page 387

RELATED REFERENCES

Declaratives (*Enterprise COBOL Language Reference*)

Chapter 2. Using data

This information is intended to help non-COBOL programmers relate terms for data used in other programming languages to COBOL terms. It introduces COBOL fundamentals for variables, structures, literals, and constants; assigning and displaying values; intrinsic (built-in) functions, and tables (arrays) and pointers.

RELATED CONCEPTS

“Storage and its addressability” on page 39

RELATED TASKS

“Using variables, structures, literals, and constants”

“Assigning values to data items” on page 27

“Displaying values on a screen or in a file (DISPLAY)” on page 35

“Using intrinsic functions (built-in functions)” on page 38

“Using tables (arrays) and pointers” on page 39

Chapter 7, “Processing data in an international environment,” on page 125

Using variables, structures, literals, and constants

Most high-level programming languages share the concept of data being represented as variables, structures (group items), literals, or constants.

The data in a COBOL program can be alphabetic, alphanumeric, double-byte character set (DBCS), national, or numeric. You can also define index-names and data items described as USAGE POINTER, USAGE FUNCTION-POINTER, USAGE PROCEDURE-POINTER, or USAGE OBJECT REFERENCE. You place all data definitions in the DATA DIVISION of your program.

RELATED TASKS

“Using variables”

“Using data items and group items” on page 24

“Using literals” on page 25

“Using constants” on page 26

“Using figurative constants” on page 26

RELATED REFERENCES

Classes and categories of data (*Enterprise COBOL Language Reference*)

Using variables

A *variable* is a data item whose value can change during a program. The value is restricted, however, to the data type that you define when you specify a name and a length for the data item.

For example, if a customer name is an alphanumeric data item in your program, you could define and use the customer name as shown below:

```
Data Division.  
01 Customer-Name           Pic X(20).  
01 Original-Customer-Name Pic X(20).  
.  
.  
.  
Procedure Division.  
  Move Customer-Name to Original-Customer-Name  
  .  
  .  
  .
```

You could instead define the customer names above as national data items by specifying their PICTURE clauses as Pic N(20) and specifying the USAGE NATIONAL clause for the items. National data items are represented in Unicode UTF-16, in which most characters are represented in 2 bytes of storage.

RELATED CONCEPTS

“Unicode and the encoding of language characters” on page 129

RELATED TASKS

“Using national data (Unicode) in COBOL” on page 130

RELATED REFERENCES

“NSYMBOL” on page 340

“Storage of character data” on page 137

PICTURE clause (*Enterprise COBOL Language Reference*)

Using data items and group items

Related data items can be parts of a hierarchical data structure. A data item that does not have subordinate data items is called an *elementary item*. A data item that is composed of one or more subordinate data items is called a *group item*.

A record can be either an elementary item or a group item. A group item can be either an *alphanumeric group item* or a *national group item*.

For example, Customer-Record below is an alphanumeric group item that is composed of two subordinate alphanumeric group items (Customer-Name and Part-Order), each of which contains elementary data items. These groups items implicitly have USAGE DISPLAY. You can refer to an entire group item or to parts of a group item in MOVE statements in the PROCEDURE DIVISION as shown below:

```
Data Division.
File Section.
FD Customer-File
   Record Contains 45 Characters.
01 Customer-Record.
   05 Customer-Name.
      10 Last-Name      Pic x(17).
      10 Filler         Pic x.
      10 Initials       Pic xx.
   05 Part-Order.
      10 Part-Name      Pic x(15).
      10 Part-Color     Pic x(10).
Working-Storage Section.
01 Orig-Customer-Name.
   05 Surname           Pic x(17).
   05 Initials          Pic x(3).
01 Inventory-Part-Name Pic x(15).
. . .
Procedure Division.
   Move Customer-Name to Orig-Customer-Name
   Move Part-Name to Inventory-Part-Name
. . .
```

You could instead define Customer-Record as a national group item that is composed of two subordinate national group items by changing the declarations in the DATA DIVISION as shown below. National group items behave in the same way as elementary category national data items in most operations. The GROUP-USAGE NATIONAL clause indicates that a group item and any group items subordinate to it are national groups. Subordinate elementary items in a national group must be explicitly or implicitly described as USAGE NATIONAL.

```

Data Division.
File Section.
FD Customer-File
   Record Contains 90 Characters.
01 Customer-Record      Group-Usage National.
   05 Customer-Name.
      10 Last-Name      Pic n(17).
      10 Filler         Pic n.
      10 Initials      Pic nn.
   05 Part-Order.
      10 Part-Name     Pic n(15).
      10 Part-Color    Pic n(10).
Working-Storage Section.
01 Orig-Customer-Name   Group-Usage National.
   05 Surname           Pic n(17).
   05 Initials         Pic n(3).
01 Inventory-Part-Name Pic n(15) Usage National.
. . .
Procedure Division.
   Move Customer-Name to Orig-Customer-Name
   Move Part-Name to Inventory-Part-Name
. . .

```

In the example above, the group items could instead specify the USAGE NATIONAL clause at the group level. A USAGE clause at the group level applies to each elementary data item in a group (and thus serves as a convenient shorthand notation). However, a group that specifies the USAGE NATIONAL clause is *not* a national group despite the representation of the elementary items within the group. Groups that specify the USAGE clause are alphanumeric groups and behave in many operations, such as moves and compares, like elementary data items of USAGE DISPLAY (except that no editing or conversion of data occurs).

RELATED CONCEPTS

“Unicode and the encoding of language characters” on page 129
“National groups” on page 133

RELATED TASKS

“Using national data (Unicode) in COBOL” on page 130
“Using national groups” on page 134

RELATED REFERENCES

“FILE SECTION entries” on page 12
“Storage of character data” on page 137
Classes and categories of group items (*Enterprise COBOL Language Reference*)
PICTURE clause (*Enterprise COBOL Language Reference*)
MOVE statement (*Enterprise COBOL Language Reference*)
USAGE clause (*Enterprise COBOL Language Reference*)

Using literals

A *literal* is a character string whose value is given by the characters themselves. If you know the value you want a data item to have, you can use a literal representation of the data value in the PROCEDURE DIVISION.

You do not need to define a data item for the value nor refer to it by using a data-name. For example, you can prepare an error message for an output file by moving an alphanumeric literal:

```
Move "Name is not valid" To Customer-Name
```

You can compare a data item to a specific integer value by using a numeric literal. In the example below, "Name is not valid" is an alphanumeric literal, and 03519 is a numeric literal:

```
01 Part-number      Pic 9(5).  
  . . .  
  If Part-number = 03519 then display "Part number was found"
```

You can use the opening delimiter N" or N' to designate a national literal if the NSYMBOL(NATIONAL) compiler option is in effect, or to designate a DBCS literal if the NSYMBOL(DBCS) compiler option is in effect.

You can use the opening delimiter NX" or NX' to designate national literals in hexadecimal notation (regardless of the setting of the NSYMBOL compiler option). Each group of four hexadecimal digits designates a single national character.

RELATED CONCEPTS

"Unicode and the encoding of language characters" on page 129

RELATED TASKS

"Using national literals" on page 131

"Using DBCS literals" on page 150

RELATED REFERENCES

"NSYMBOL" on page 340

Literals (*Enterprise COBOL Language Reference*)

Using constants

A *constant* is a data item that has only one value. COBOL does not define a construct for constants. However, you can define a data item with an initial value by coding a VALUE clause in the data description (instead of coding an INITIALIZE statement).

```
Data Division.  
01 Report-Header  pic x(50) value "Company Sales Report".  
  . . .  
01 Interest      pic 9v9999 value 1.0265.
```

The example above initializes an alphanumeric and a numeric data item. You can likewise use a VALUE clause in defining a national or DBCS constant.

RELATED TASKS

"Using national data (Unicode) in COBOL" on page 130

"Coding for use of DBCS support" on page 150

Using figurative constants

Certain commonly used constants and literals are available as reserved words called *figurative constants*: ZERO, SPACE, HIGH-VALUE, LOW-VALUE, QUOTE, NULL, and ALL *literal*. Because they represent fixed values, figurative constants do not require a data definition.

For example:

```
Move Spaces To Report-Header
```

RELATED TASKS

"Using national-character figurative constants" on page 132

"Coding for use of DBCS support" on page 150

Assigning values to data items

After you have defined a data item, you can assign a value to it at any time. Assignment takes many forms in COBOL, depending on what you want to do.

Table 3. Assignment to data items in a program

What you want to do	How to do it
Assign values to a data item or large data area.	Use one of these ways: <ul style="list-style-type: none"> • INITIALIZE statement • MOVE statement • STRING or UNSTRING statement • VALUE clause (to set data items to the values you want them to have when the program is in initial state)
Assign the results of arithmetic.	Use COMPUTE, ADD, SUBTRACT, MULTIPLY, or DIVIDE statements.
Examine or replace characters or groups of characters in a data item.	Use the INSPECT statement.
Receive values from a file.	Use the READ (or READ INTO) statement.
Receive values from a system input device or a file.	Use the ACCEPT statement.
Establish a constant.	Use the VALUE clause in the definition of the data item, and do not use the data item as a receiver. Such an item is in effect a constant even though the compiler does not enforce read-only constants.
One of these actions: <ul style="list-style-type: none"> • Place a value associated with a table element in an index. • Set the status of an external switch to ON or OFF. • Move data to a condition-name to make the condition true. • Set a POINTER, PROCEDURE-POINTER, or FUNCTION-POINTER data item to an address. • Associate an OBJECT REFERENCE data item with an object instance. 	Use the SET statement.

“Examples: initializing data items” on page 28

RELATED TASKS

“Initializing a structure (INITIALIZE)” on page 30

“Assigning values to elementary data items (MOVE)” on page 32

“Assigning values to group data items (MOVE)” on page 33

“Assigning input from a screen or file (ACCEPT)” on page 34

“Joining data items (STRING)” on page 105

“Splitting data items (UNSTRING)” on page 107

“Assigning arithmetic results (MOVE or COMPUTE)” on page 34

“Tallying and replacing data items (INSPECT)” on page 115

Chapter 7, “Processing data in an international environment,” on page 125

Examples: initializing data items

The following examples show how you can initialize many kinds of data items, including alphanumeric, national-edited, and numeric-edited data items, by using INITIALIZE statements.

An INITIALIZE statement is functionally equivalent to one or more MOVE statements. The related tasks about initializing show how you can use an INITIALIZE statement on a group item to conveniently initialize all the subordinate data items that are in a given data category.

Initializing a data item to blanks or zeros:

INITIALIZE *identifier-1*

<i>identifier-1</i> PICTURE	<i>identifier-1</i> before	<i>identifier-1</i> after
9(5)	12345	00000
X(5)	AB123	bbbb ¹
N(3)	004100420031 ²	002000200020 ³
99XX9	12AB3	bbbb ¹
XXBX/XX	ABbC/DE	bbb/bb ¹
**99.9CR	1234.5CR	**00.0bb ¹
A(5)	ABCDE	bbbb ¹
+99.99E+99	+12.34E+02	+00.00E+00

- The symbol *b* represents a blank space.
- Hexadecimal representation of the national (UTF-16) characters 'AB1'. The example assumes that *identifier-1* has Usage National.
- Hexadecimal representation of the national (UTF-16) characters ' ' (three blank spaces). Note that if *identifier-1* were not defined as Usage National, and if NSYMBOL(DFCS) were in effect, INITIALIZE would instead store DFCS spaces ('4040') into *identifier-1*.

Initializing an alphanumeric data item:

```
01 ALPHANUMERIC-1 PIC X VALUE "y".
01 ALPHANUMERIC-3 PIC X(1) VALUE "A".
. . .
INITIALIZE ALPHANUMERIC-1
REPLACING ALPHANUMERIC DATA BY ALPHANUMERIC-3
```

ALPHANUMERIC-3	ALPHANUMERIC-1 before	ALPHANUMERIC-1 after
A	y	A

Initializing an alphanumeric right-justified data item:

```
01 ANJUST PIC X(8) VALUE SPACES JUSTIFIED RIGHT.
01 ALPHABETIC-1 PIC A(4) VALUE "ABCD".
. . .
INITIALIZE ANJUST
REPLACING ALPHANUMERIC DATA BY ALPHABETIC-1
```

ALPHABETIC-1	ANJUST before	ANJUST after
ABCD	bbbbbbbb ¹	bbbABCD ¹

- The symbol *b* represents a blank space.

Initializing an alphanumeric-edited data item:

```

01 ALPHANUM-EDIT-1 PIC XXBX/XXX VALUE "AbbC/DEF".
01 ALPHANUM-EDIT-3 PIC X/BB VALUE "M/bb".
. . .
INITIALIZE ALPHANUM-EDIT-1
REPLACING ALPHANUMERIC-EDITED DATA BY ALPHANUM-EDIT-3

```

ALPHANUM-EDIT-3	ALPHANUM-EDIT-1 before	ALPHANUM-EDIT-1 after
M/bb ¹	AbbC/DEF ¹	M/bb/bbb ¹
1. The symbol <i>b</i> represents a blank space.		

Initializing a national data item:

```

01 NATIONAL-1 PIC NN USAGE NATIONAL VALUE N"AB".
01 NATIONAL-3 PIC NN USAGE NATIONAL VALUE N"CD".
. . .
INITIALIZE NATIONAL-1
REPLACING NATIONAL DATA BY NATIONAL-3

```

NATIONAL-3	NATIONAL-1 before	NATIONAL-1 after
00430044 ¹	00410042 ²	00430044 ¹
1. Hexadecimal representation of the national characters 'CD' 2. Hexadecimal representation of the national characters 'AB'		

Initializing a national-edited data item:

```

01 NATL-EDIT-1 PIC 0NN USAGE NATIONAL VALUE N"123".
01 NATL-3 PIC NNN USAGE NATIONAL VALUE N"456".
. . .
INITIALIZE NATL-EDIT-1
REPLACING NATIONAL-EDITED DATA BY NATL-3

```

NATL-3	NATL-EDIT-1 before	NATL-EDIT-1 after
003400350036 ¹	003100320033 ²	003000340035 ³
1. Hexadecimal representation of the national characters '456' 2. Hexadecimal representation of the national characters '123' 3. Hexadecimal representation of the national characters '045'		

Initializing a numeric (zoned decimal) data item:

```

01 NUMERIC-1 PIC 9(8) VALUE 98765432.
01 NUM-INT-CMPT-3 PIC 9(7) COMP VALUE 1234567.
. . .
INITIALIZE NUMERIC-1
REPLACING NUMERIC DATA BY NUM-INT-CMPT-3

```

NUM-INT-CMPT-3	NUMERIC-1 before	NUMERIC-1 after
1234567	98765432	01234567

Initializing a numeric (national decimal) data item:

```

01 NAT-DEC-1 PIC 9(3) USAGE NATIONAL VALUE 987.
01 NUM-INT-BIN-3 PIC 9(2) BINARY VALUE 12.
. . .
INITIALIZE NAT-DEC-1
REPLACING NUMERIC DATA BY NUM-INT-BIN-3

```

NUM-INT-BIN-3	NAT-DEC-1 before	NAT-DEC-1 after
12	003900380037 ¹	003000310032 ²
1. Hexadecimal representation of the national characters '987' 2. Hexadecimal representation of the national characters '012'		

Initializing a numeric-edited (USAGE DISPLAY) data item:

```

01 NUM-EDIT-DISP-1 PIC $ZZ9V VALUE "$127".
01 NUM-DISP-3      PIC 999V  VALUE 12.
. . .
  INITIALIZE NUM-EDIT-DISP-1
    REPLACING NUMERIC-EDITED DATA BY NUM-DISP-3
  
```

NUM-DISP-3	NUM-EDIT-DISP-1 before	NUM-EDIT-DISP-1 after
012	\$127	\$ 12

Initializing a numeric-edited (USAGE NATIONAL) data item:

```

01 NUM-EDIT-NATL-1 PIC $ZZ9V NATIONAL VALUE N"$127".
01 NUM-NATL-3      PIC 999V  NATIONAL VALUE 12.
. . .
  INITIALIZE NUM-EDIT-NATL-1
    REPLACING NUMERIC-EDITED DATA BY NUM-NATL-3
  
```

NUM-NATL-3	NUM-EDIT-NATL-1 before	NUM-EDIT-NATL-1 after
003000310032 ¹	0024003100320037 ²	0024002000310032 ³
1. Hexadecimal representation of the national characters '012' 2. Hexadecimal representation of the national characters '\$127' 3. Hexadecimal representation of the national characters '\$ 12'		

RELATED TASKS

"Initializing a structure (INITIALIZE)"
 "Initializing a table (INITIALIZE)" on page 73
 "Defining numeric data" on page 43

RELATED REFERENCES

"NSYMBOL" on page 340

Initializing a structure (INITIALIZE)

You can reset the values of all subordinate data items in a group item by applying the INITIALIZE statement to that group item. However, it is inefficient to initialize an entire group unless you really need all the items in the group to be initialized.

The following example shows how you can reset fields to spaces and zeros in transaction records that a program produces. The values of the fields are not identical in each record that is produced. (The transaction record is defined as an alphanumeric group item, TRANSACTION-OUT.)

```

01 TRANSACTION-OUT.
   05 TRANSACTION-CODE      PIC X.
   05 PART-NUMBER           PIC 9(6).
   05 TRANSACTION-QUANTITY  PIC 9(5).
   05 PRICE-FIELDS.
     10 UNIT-PRICE          PIC 9(5)V9(2).
  
```

```

10 DISCOUNT          PIC V9(2).
10 SALES-PRICE        PIC 9(5)V9(2).

```

```

. . .
INITIALIZE TRANSACTION-OUT

```

Record	TRANSACTION-OUT before	TRANSACTION-OUT after
1	R0013830002400000000000000000	b000000000000000000000000000 ¹
2	R0013900004800000000000000000	b000000000000000000000000000 ¹
3	S0014100001200000000000000000	b000000000000000000000000000 ¹
4	C0013830000000000425000000000	b000000000000000000000000000 ¹
5	C002010000000000000100000000	b000000000000000000000000000 ¹

1. The symbol *b* represents a blank space.

You can likewise reset the values of all the subordinate data items in a national group item by applying the INITIALIZE statement to that group item. The following structure is similar to the preceding structure, but instead uses Unicode UTF-16 data:

```

01 TRANSACTION-OUT GROUP-USAGE NATIONAL.
   05 TRANSACTION-CODE          PIC N.
   05 PART-NUMBER              PIC 9(6).
   05 TRANSACTION-QUANTITY     PIC 9(5).
   05 PRICE-FIELDS.
       10 UNIT-PRICE           PIC 9(5)V9(2).
       10 DISCOUNT           PIC V9(2).
       10 SALES-PRICE         PIC 9(5)V9(2).

```

```

. . .
INITIALIZE TRANSACTION-OUT

```

Regardless of the previous contents of the transaction record, after the INITIALIZE statement above is executed:

- TRANSACTION-CODE contains NX"0020" (a national space).
- Each of the remaining 27 national character positions of TRANSACTION-OUT contains NX"0030" (a national-decimal zero).

When you use an INITIALIZE statement to initialize an alphanumeric or national group data item, the data item is processed as a group item, that is, with group semantics. The elementary data items within the group are recognized and processed, as shown in the examples above. If you do not code the REPLACING phrase of the INITIALIZE statement:

- SPACE is the implied sending item for alphabetic, alphanumeric, alphanumeric-edited, DBCS, category national, and national-edited receiving items.
- ZERO is the implied sending item for numeric and numeric-edited receiving items.

RELATED CONCEPTS

"National groups" on page 133

RELATED TASKS

"Initializing a table (INITIALIZE)" on page 73

"Using national groups" on page 134

RELATED REFERENCES

INITIALIZE statement (*Enterprise COBOL Language Reference*)

Assigning values to elementary data items (MOVE)

Use a MOVE statement to assign a value to an elementary data item.

The following statement assigns the contents of an elementary data item, Customer-Name, to the elementary data item Orig-Customer-Name:

```
Move Customer-Name to Orig-Customer-Name
```

If Customer-Name is longer than Orig-Customer-Name, truncation occurs on the right. If Customer-Name is shorter, the extra character positions on the right in Orig-Customer-Name are filled with spaces.

For data items that contain numbers, moves can be more complicated than with character data items because there are several ways in which numbers can be represented. In general, the algebraic values of numbers are moved if possible, as opposed to the digit-by-digit moves that are performed with character data. For example, after the MOVE statement below, Item-x contains the value 3.0, represented as 0030:

```
01 Item-x      Pic 999v9.
. . .
  Move 3.06 to Item-x
```

You can move an alphabetic, alphanumeric, alphanumeric-edited, DBCS, integer, or numeric-edited data item to a category national or national-edited data item; the sending item is converted. You can move a national data item to a category national or national-edited data item. If the content of a category national data item has a numeric value, you can move that item to a numeric, numeric-edited, external floating-point, or internal floating-point data item. You can move a national-edited data item only to a category national data item or another national-edited data item. Padding or truncation might occur.

For complete details about elementary moves, see the related reference below about the MOVE statement.

The following example shows an alphanumeric data item in the Greek language that is moved to a national data item:

```
CBL CODEPAGE(00875)
. . .
01 Data-in-Unicode Pic N(100) usage national.
01 Data-in-Greek   Pic X(100).
. . .
  Read Greek-file into Data-in-Greek
  Move Data-in-Greek to Data-in-Unicode
```

RELATED CONCEPTS

“Unicode and the encoding of language characters” on page 129

RELATED TASKS

“Assigning values to group data items (MOVE)” on page 33

“Converting to or from national (Unicode) representation” on page 137

RELATED REFERENCES

“CODEPAGE” on page 313

Classes and categories of data (*Enterprise COBOL Language Reference*)

MOVE statement (*Enterprise COBOL Language Reference*)

Assigning values to group data items (MOVE)

Use the MOVE statement to assign values to group data items.

You can move a national group item (a data item that is described with the GROUP-USAGE NATIONAL clause) to another national group item. The compiler processes the move as though each national group item were an elementary item of category national, that is, as if each item were described as PIC N(*m*), where *m* is the length of that item in national character positions.

You can move an alphanumeric group item to an alphanumeric group item or to a national group item. You can also move a national group item to an alphanumeric group item. The compiler performs such moves as group moves, that is, without consideration of the individual elementary items in the sending or receiving group, and without conversion of the sending data item. Be sure that the subordinate data descriptions in the sending and receiving group items are compatible. The moves occur even if a destructive overlap could occur at run time.

You can code the CORRESPONDING phrase in a MOVE statement to move subordinate elementary items from one group item to the identically named corresponding subordinate elementary items in another group item:

```
01 Group-X.  
   02 T-Code   Pic X    Value "A".  
   02 Month   Pic 99   Value 04.  
   02 State   Pic XX   Value "CA".  
   02 Filler  PIC X.  
01 Group-N   Group-Usage National.  
   02 State   Pic NN.  
   02 Month   Pic 99.  
   02 Filler  Pic N.  
   02 Total  Pic 999.  
.  
.  
.  
MOVE CORR Group-X TO Group-N
```

In the example above, State and Month within Group-N receive the values in national representation of State and Month, respectively, from Group-X. The other data items in Group-N are unchanged. (Filler items in a receiving group item are unchanged by a MOVE CORRESPONDING statement.)

In a MOVE CORRESPONDING statement, sending and receiving group items are treated as group items, not as elementary data items; group semantics apply. That is, the elementary data items within each group are recognized, and the results are the same as if each pair of corresponding data items were referenced in a separate MOVE statement. Data conversions are performed according to the rules for the MOVE statement as specified in the related reference below. For details about which types of elementary data items correspond, see the related reference about the CORRESPONDING phrase.

RELATED CONCEPTS

“Unicode and the encoding of language characters” on page 129

“National groups” on page 133

RELATED TASKS

“Assigning values to elementary data items (MOVE)” on page 32

“Using national groups” on page 134

“Converting to or from national (Unicode) representation” on page 137

RELATED REFERENCES

Classes and categories of group items (*Enterprise COBOL Language Reference*)

MOVE statement (*Enterprise COBOL Language Reference*)

CORRESPONDING phrase (*Enterprise COBOL Language Reference*)

Assigning arithmetic results (MOVE or COMPUTE)

When assigning a number to a data item, consider using the COMPUTE statement instead of the MOVE statement.

```
Move w to z
Compute z = w
```

In the example above, the two statements in most cases have the same effect. The MOVE statement however carries out the assignment with truncation. You can use the DIAGTRUNC compiler option to request that the compiler issue a warning for MOVE statements that might truncate numeric receivers.

When significant left-order digits would be lost in execution, the COMPUTE statement can detect the condition and allow you to handle it. If you use the ON SIZE ERROR phrase of the COMPUTE statement, the compiler generates code to detect a size-overflow condition. If the condition occurs, the code in the ON SIZE ERROR phrase is performed, and the content of z remains unchanged. If you do not specify the ON SIZE ERROR phrase, the assignment is carried out with truncation. There is no ON SIZE ERROR support for the MOVE statement.

You can also use the COMPUTE statement to assign the result of an arithmetic expression or intrinsic function to a data item. For example:

```
Compute z = y + (x ** 3)
Compute x = Function Max(x y z)
```

You can assign the results of date, time, mathematical, and other calculations to data items by using Language Environment callable services. Language Environment services are available through a standard COBOL CALL statement, and the values they return are passed in the parameters of the CALL statement. For example, you can call the Language Environment service CEESIABS to find the absolute value of a data item by coding the following statement:

```
Call 'CEESIABS' Using Arg, Feedback-code, Result.
```

As a result of this call, data item Result is assigned the absolute value of the value in data item Arg; data item Feedback-code contains the return code that indicates whether the service completed successfully. You have to define all the data items in the DATA DIVISION using the correct descriptions according to the requirements of the particular callable service. For the example above, the data items could be defined as follows:

```
77 Arg           Pic s9(9)  Binary.
77 Feedback-code Pic x(12)  Display.
77 Result        Pic s9(9)  Binary.
```

RELATED REFERENCES

"DIAGTRUNC" on page 320

Intrinsic functions (*Enterprise COBOL Language Reference*)

Language Environment Programming Reference (Callable services)

Assigning input from a screen or file (ACCEPT)

One way to assign a value to a data item is to read the value from a screen or a file.

To enter data from the screen, first associate the monitor with a mnemonic-name in the SPECIAL-NAMES paragraph. Then use ACCEPT to assign the line of input entered at the screen to a data item. For example:

```
Environment Division.  
Configuration Section.  
Special-Names.  
    Console is Names-Input.  
    . . .  
    Accept Customer-Name From Names-Input
```

To read from a file instead of the screen, make the following change:

- Change Console to *device*, where *device* is any valid system device (for example, SYSIN). For example:

```
SYSIN is Names-Input
```

device can be a ddname that references a z/OS UNIX file system path. If this ddname is not defined and your program is running in the z/OS UNIX environment, stdin is the input source. If this ddname is not defined and your program is not running in the z/OS UNIX environment, the ACCEPT statement fails.

When you use the ACCEPT statement, you can assign a value to an alphanumeric or national group item, or to an elementary data item that has USAGE DISPLAY, USAGE DISPLAY-1, or USAGE NATIONAL.

When you assign a value to a USAGE NATIONAL data item, input data from the console is converted from the EBCDIC code page specified in the CODEPAGE compiler option to national (Unicode UTF-16) representation. This is the only case where conversion of national data is done when you use the ACCEPT statement. Conversion is done in this case because the input is known to be coming from a screen.

To have conversion done when the input data is from any other device, use the NATIONAL-OF intrinsic function.

RELATED CONCEPTS

“Unicode and the encoding of language characters” on page 129

RELATED TASKS

“Converting alphanumeric or DBCS to national (NATIONAL-OF)” on page 139

RELATED REFERENCES

“CODEPAGE” on page 313

ACCEPT statement (*Enterprise COBOL Language Reference*)

SPECIAL-NAMES paragraph (*Enterprise COBOL Language Reference*)

Displaying values on a screen or in a file (DISPLAY)

You can display the value of a data item on a screen or write it to a file by using the DISPLAY statement.

```
Display "No entry for surname '" Customer-Name "' found in the file."
```

In the example above, if the content of data item *Customer-Name* is JOHNSON, then the statement displays the following message on the system logical output device:

```
No entry for surname 'JOHNSON' found in the file.
```

To write data to a destination other than the system logical output device, use the UPON phrase with a destination other than SYSOUT. For example, the following statement writes to the file that is specified in the SYSPUNCH DD statement:

```
Display "Hello" upon syspunch.
```

You can specify a file in the z/OS UNIX file system by using the SYSPUNCH DD statement. For example, the following definition causes DISPLAY output to be written to the file `/u/userid/cobol/demo.lst`:

```
//SYSPUNCH DD PATH='/u/userid/cobol/demo.lst',  
// PATHOPTS=(OWRONLY,OCREAT,OTRUNC),PATHMODE=SIRWXU,  
// FILEDATA=TEXT
```

The following statement writes to the job log or console and to the TSO screen if you are running under TSO:

```
Display "Hello" upon console.
```

When you display the value of a USAGE NATIONAL data item to the console, the data item is converted from Unicode (UTF-16) representation to EBCDIC based on the value of the CODEPAGE option. This is the only case in which conversion of national data is done when you use the DISPLAY statement. Conversion is done in this case because the output is known to be directed to a screen.

To have a national data item be converted when you direct output to a different device, use the DISPLAY-OF intrinsic function, as in the following example:

```
01 Data-in-Unicode pic N(10) usage national.  
  . . .  
  . . . Display function Display-of(Data-in-Unicode, 00037)
```

RELATED CONCEPTS

“Unicode and the encoding of language characters” on page 129

RELATED TASKS

“Displaying data on the system logical output device”

“Using WITH NO ADVANCING” on page 37

“Converting national to alphanumeric (DISPLAY-OF)” on page 139

“Coding COBOL programs to run under CICS” on page 429

RELATED REFERENCES

“CODEPAGE” on page 313

DISPLAY statement (*Enterprise COBOL Language Reference*)

Displaying data on the system logical output device

To write data to the system logical output device, either omit the UPON clause or use the UPON clause with destination SYSOUT.

```
Display "Hello" upon sysout.
```

The output is directed to the ddname that you specify in the OUTDD compiler option. You can specify a file in the z/OS UNIX file system with this ddname.

If the OUTDD ddname is not allocated and you are not running in the z/OS UNIX environment, a default DD of SYSOUT=* is allocated. If the OUTDD ddname is not allocated and you are running in the z/OS UNIX environment, the `_IGZ_SYSOUT` environment variable is used as follows:

Undefined or set to stdout

Output is routed to stdout (file descriptor 1).

Set to stderr

Output is routed to stderr (file descriptor 2).

Otherwise (set to something other than stdout or stderr)

The DISPLAY statement fails; a severity-3 Language Environment condition is raised.

When DISPLAY output is routed to stdout or stderr, the output is not subdivided into records. The output is written as a single stream of characters without line breaks.

If OUTDD and the Language Environment runtime option MSGFILE specify the same ddname, both DISPLAY output and Language Environment runtime diagnostics are routed to the Language Environment message file.

RELATED TASKS

"Setting and accessing environment variables" on page 464

RELATED REFERENCES

"OUTDD" on page 348

DISPLAY statement (*Enterprise COBOL Language Reference*)

Using WITH NO ADVANCING

If you specify the WITH NO ADVANCING phrase, and output is going to a ddname, the printer control character + (plus) is placed into the first output position from the *next* DISPLAY statement. + is the ANSI-defined printer control character that suppresses line spacing before a record is printed.

If you specify the WITH NO ADVANCING phrase and the output is going to stdout or stderr, a newline character is not appended to the end of the stream. A subsequent DISPLAY statement might add additional characters to the end of the stream.

If you do not specify WITH NO ADVANCING, and the output is going to a ddname, the printer control character ' ' (space) is placed into the first output position from the next DISPLAY statement, indicating single-spaced output.

```
DISPLAY "ABC"
DISPLAY "CDEF" WITH NO ADVANCING
DISPLAY "GHIJK" WITH NO ADVANCING
DISPLAY "LMNOPQ"
DISPLAY "RSTVMX"
```

If you code the statements above, the result sent to the output device is:

```
ABC
CDEF
+GHIJK
+LMNOPQ
RSTVMX
```

The output that is printed depends on how the output device interprets printer control characters.

If you do not specify the WITH NO ADVANCING phrase and the output is going to stdout or stderr, a newline character is appended to the end of the stream.

RELATED REFERENCES

DISPLAY statement (*Enterprise COBOL Language Reference*)

Using intrinsic functions (built-in functions)

Some high-level programming languages have built-in functions that you can reference in your program as if they were variables that have defined attributes and a predetermined value. In COBOL, these functions are called *intrinsic functions*. They provide capabilities for manipulating strings and numbers.

Because the value of an intrinsic function is derived automatically at the time of reference, you do not need to define functions in the DATA DIVISION. Define only the nonliteral data items that you use as arguments. Figurative constants are not allowed as arguments.

A *function-identifier* is the combination of the COBOL reserved word FUNCTION followed by a function name (such as Max), followed by any arguments to be used in the evaluation of the function (such as x, y, z). For example, the groups of highlighted words below are function-identifiers:

```
Unstring Function Upper-case(Name) Delimited By Space
        Into Fname Lname
Compute A = 1 + Function Log10(x)
Compute M = Function Max(x y z)
```

A function-identifier represents both the invocation of the function and the data value returned by the function. Because it actually represents a data item, you can use a function-identifier in most places in the PROCEDURE DIVISION where a data item that has the attributes of the returned value can be used.

The COBOL word function is a reserved word, but the function-names are not reserved. You can use them in other contexts, such as for the name of a data item. For example, you could use Sqrt to invoke an intrinsic function and to name a data item in your program:

```
Working-Storage Section.
01 x                Pic 99 value 2.
01 y                Pic 99 value 4.
01 z                Pic 99 value 0.
01 Sqrt             Pic 99 value 0.
. . .
  Compute Sqrt = 16 ** .5
  Compute z = x + Function Sqrt(y)
. . .
```

A function-identifier represents a value that is of one of these types: alphanumeric, national, numeric, or integer. You can include a substring specification (reference modifier) in a function-identifier for alphanumeric or national functions. Numeric intrinsic functions are further classified according to the type of numbers they return.

The functions MAX and MIN can return either type of value depending on the type of arguments you supply.

Functions can reference other functions as arguments provided that the results of the nested functions meet the requirements for the arguments of the outer function. For example, Function Sqrt(5) returns a numeric value. Thus, the three arguments to the MAX function below are all numeric, which is an allowable argument type for this function:

```
Compute x = Function Max((Function Sqrt(5)) 2.5 3.5)
```

RELATED TASKS

“Processing table items using intrinsic functions” on page 89

“Converting data items (intrinsic functions)” on page 116

“Evaluating data items (intrinsic functions)” on page 119

Using tables (arrays) and pointers

In COBOL, arrays are called *tables*. A table is a set of logically consecutive data items that you define in the DATA DIVISION by using the OCCURS clause.

Pointers are data items that contain virtual storage addresses. You define them either explicitly with the USAGE IS POINTER clause in the DATA DIVISION or implicitly as ADDRESS OF special registers.

You can perform the following operations with pointer data items:

- Pass them between programs by using the CALL . . . BY REFERENCE statement.
- Move them to other pointers by using the SET statement.
- Compare them to other pointers for equality by using a relation condition.
- Initialize them to contain an invalid address by using VALUE IS NULL.

Use pointer data items to:

- Accomplish limited base addressing, particularly if you want to pass and receive addresses of a record area that is defined with OCCURS DEPENDING ON and is therefore variably located.
- Handle a chained list.

RELATED TASKS

“Defining a table (OCCURS)” on page 67

“Using procedure and function pointers” on page 487

Storage and its addressability

When you run COBOL programs, the programs and the data that they use reside in virtual storage. Storage that you use with COBOL can be either below the 16 MB line or above the 16 MB line but below the 2 GB bar. Two modes of addressing are available to address this storage: 24-bit and 31-bit.

You can address storage below (but not above) the 16 MB line with 24-bit addressing. You can address storage either above or below the 16 MB line with 31-bit addressing. *Unrestricted storage* is addressable by 31-bit addressing and therefore encompasses all the storage available to your program, both above and below the 16 MB line.

Enterprise COBOL does not directly exploit the 64-bit virtual addressing capability of z/OS; however, COBOL applications running in 31-bit or 24-bit addressing mode are fully supported on 64-bit z/OS systems.

Addressing mode (AMODE) is the attribute that tells which hardware addressing mode is supported by your program: 24-bit addressing, 31-bit addressing, or either 24-bit or 31-bit addressing. These attributes are AMODE 24, AMODE 31, and AMODE ANY, respectively. The program object and the executing program each have an AMODE attribute. Enterprise COBOL V5.1.1 object programs are either AMODE MIN for cases where AMODE 24 is possible, or AMODE 31 in all other cases. See “Restrictions for AMODE” on page 40.

Residency mode (RMODE) is the attribute of a program object that identifies where in virtual storage the program will reside: below the 16 MB line, or either below or above. This attribute is RMODE 24 or RMODE ANY.

Enterprise COBOL uses Language Environment services to control the storage used at run time. Thus COBOL compiler options and Language Environment runtime options influence the AMODE and RMODE attributes of your program and data, alone and in combination:

- DATA** Compiler option that influences the location of storage for WORKING-STORAGE data, I-O buffers, and parameter lists for programs compiled with RENT.
- RMODE** Compiler option that influences the residency mode.
- RENT** Compiler option to generate a reentrant program.
- HEAP** Runtime option that controls storage for the runtime heap. For example, COBOL WORKING-STORAGE is allocated from heap storage when the COBOL program is compiled with the RENT option and is in one of the following cases:
- Compiled with Enterprise COBOL V4.2 or earlier releases
 - Compiled with the DATA(24) compiler option
 - Running in CICS
 - A COBOL V5.1.1 in a program object that contains only COBOL programs (V5.1.1, V4.2 or earlier) and assembly programs. There are no Language Environment interlanguage calls within the program object and no COBOL V5.1.0 programs.
 - A COBOL V5 program in a program object where the main entry point is COBOL V5. In this case, the program object can contain Language Environment interlanguage calls, with COBOL statically linking with C, C++ or PL/I. All COBOL V5 programs within such program objects (even if they are not the main entry point) have their WORKING-STORAGE allocated from heap storage.
- STACK** Runtime option that controls storage for the runtime stack. For example, COBOL LOCAL-STORAGE is allocated from stack storage.
- ALL31** Runtime option that specifies whether an application can run entirely in AMODE 31.

Restrictions for AMODE

AMODE 24 execution is not supported in the following cases, and the applications must run in AMODE 31:

- Programs containing XML PARSE statements
- Programs containing XML GENERATE statements
- Program objects containing COBOL bound together with C, C++, or PL/I programs, and communicating via static CALL
- Programs containing object-oriented language syntax, such as INVOKE statements, or object-oriented class definitions
- Programs compiled with any of the following compiler options:
 - DLL
 - PGMNAME(LONGUPPER)
 - PGMNAME(LONGMIXED)
- Multithreaded applications

Note: A program compiled with the THREAD option can run in AMODE 24, but only in an application that does not have multiple threads or PL/I tasks.

- Programs run from the z/OS UNIX file system

Note: An AMODE 31 driver program resident in the z/OS UNIX file system can contain a dynamic call to an AMODE 24 program module resident in an MVS PDS or PDSE.

- Programs used as COBOL compiler exit modules that are specified on the EXIT compiler option
- Language Environment enclaves that use XPLINK, including either the enclaves that contain non-COBOL programs compiled with the XPLINK compiler option, or run with the XPLINK runtime option

Note: To run COBOL programs with addressing mode 24, you must compile all COBOL programs with Enterprise COBOL V5.1.1, or later versions; or Enterprise COBOL V4.2 or earlier versions. If any component of a program object is compiled with Enterprise COBOL V5.1.0, the program object must run in addressing mode 31. COBOL programs that run with addressing mode 24 must be linked with the binder option RMODE(24).

Settings for RMODE

The RMODE and RENT options determine the RMODE attribute of your program.

Table 4. Effect of RMODE and RENT compiler options on the RMODE attribute

RMODE compiler option	RENT compiler option	RMODE attribute
RMODE(AUTO)	RENT	RMODE ANY
RMODE(AUTO)	NORENT	RMODE 24
RMODE(24)	RENT or NORENT	RMODE 24
RMODE(ANY)	RENT	RMODE ANY
RMODE(ANY)	NORENT	Compiler option conflict. If the NORENT option is specified, the RMODE(24) or RMODE(AUTO) compiler option must be specified.

Link-edit considerations: When the object code that COBOL generates has an attribute of RMODE 24, you must link-edit it with RMODE 24. When the object code that COBOL generates has an attribute of RMODE ANY, you can link-edit it with RMODE ANY or RMODE 24.

Storage restrictions for passing data

Do not pass parameters that are allocated in storage above the 16 MB line to AMODE 24 subprograms. Force the WORKING-STORAGE data and parameter lists below the line for programs that run in 31-bit addressing mode and pass data to programs that run in AMODE 24:

- Compile with the RENT and DATA(24) compiler options, or if the WORKING-STORAGE is on the HEAP (see previous description of the HEAP option), run them with the HEAP(, ,BELOW) runtime option.
- Compile with the NORENT compiler option.

Location of data areas

For reentrant programs, the DATA compiler option, and the HEAP runtime option control whether storage for data areas such as WORKING-STORAGE SECTION and FD record areas is obtained from below the 16 MB line or from unrestricted storage. Compile programs with RENT and RMODE(ANY) or RMODE(AUTO) if they will be run with 31-bit addressing in virtual storage addresses above the 16 MB line. The DATA option does not affect programs that are compiled with NORENT.

Storage for LOCAL-STORAGE data

The location of LOCAL-STORAGE data items is controlled by the STACK runtime option and the AMODE of the program. LOCAL-STORAGE data items are acquired in unrestricted storage when the STACK(, , ANYWHERE) runtime option is in effect and the program is running in AMODE 31. Otherwise LOCAL-STORAGE is acquired below the 16 MB line. The DATA compiler option does not influence the location of LOCAL-STORAGE data.

Storage for external data

In addition to affecting how storage is obtained for dynamic data areas (WORKING-STORAGE, FD record areas, and parameter lists), the DATA compiler option can also influence where storage for EXTERNAL data is obtained. Storage required for EXTERNAL data is obtained from unrestricted storage if the following conditions are met:

- The program is compiled with the DATA(31) and RENT compiler options.
- The HEAP(, , ANYWHERE) runtime option is in effect.
- The ALL31(ON) runtime option is in effect.

In all other cases, the storage for EXTERNAL data is obtained from below the 16 MB line. If you specify the ALL31(ON) runtime option, all the programs in the run unit must be capable of running in 31-bit addressing mode.

Storage for QSAM input-output buffers

The DATA compiler option can also influence where input-output buffers for QSAM files are obtained. See the related references below for information about allocation of buffers for QSAM files and the DATA compiler option.

RELATED CONCEPTS

“AMODE switching” on page 479

Language Environment Programming Guide (AMODE considerations for heap storage)

RELATED TASKS

Chapter 24, “Using subprograms,” on page 473

Chapter 25, “Sharing data,” on page 491

RELATED REFERENCES

“Allocation of buffers for QSAM files” on page 181

“Allocation of record areas for VSAM files” on page 209

“DATA” on page 318

“RENT” on page 352

“RMODE” on page 353

“Performance-related compiler options” on page 669

Language Environment Programming Reference (HEAP, STACK, ALL31)

MVS Program Management: User's Guide and Reference

Chapter 3. Working with numbers and arithmetic

In general, you can view COBOL numeric data as a series of decimal digit positions. However, numeric items can also have special properties such as an arithmetic sign or a currency sign.

To define, display, and store numeric data so that you can perform arithmetic operations efficiently:

- Use the PICTURE clause and the characters 9, +, -, P, S, and V to define numeric data.
- Use the PICTURE clause and editing characters (such as Z, comma, and period) along with MOVE and DISPLAY statements to display numeric data.
- Use the USAGE clause with various formats to control how numeric data is stored.
- Use the numeric class test to validate that data values are appropriate.
- Use ADD, SUBTRACT, MULTIPLY, DIVIDE, and COMPUTE statements to perform arithmetic.
- Use the CURRENCY SIGN clause and appropriate PICTURE characters to designate the currency you want.

RELATED TASKS

"Defining numeric data"

"Displaying numeric data" on page 45

"Controlling how numeric data is stored" on page 46

"Checking for incompatible data (numeric class test)" on page 54

"Performing arithmetic" on page 56

"Using currency signs" on page 65

Defining numeric data

Define numeric items by using the PICTURE clause with the character 9 in the data description to represent the decimal digits of the number. Do not use an X, which is for alphanumeric data items.

For example, Count-y below is a numeric data item, an external decimal item that has USAGE DISPLAY (a *zoned decimal item*):

```
05 Count-y      Pic 9(4) Value 25.
05 Customer-name Pic X(20) Value "Johnson".
```

You can similarly define numeric data items to hold national characters (UTF-16). For example, Count-n below is an external decimal data item that has USAGE NATIONAL (a *national decimal item*):

```
05 Count-n      Pic 9(4) Value 25 Usage National.
```

You can code up to 18 digits in the PICTURE clause when you compile using the default compiler option ARITH(COMPAT) (referred to as *compatibility mode*). When you compile using ARITH(EXTEND) (referred to as *extended mode*), you can code up to 31 digits in the PICTURE clause.

Other characters of special significance that you can code are:

P Indicates leading or trailing zeros

- S** Indicates a sign, positive or negative
- V** Implies a decimal point

The **s** in the following example means that the value is signed:

```
05 Price Pic s99v99.
```

The field can therefore hold a positive or a negative value. The **v** indicates the position of an implied decimal point, but does not contribute to the size of the item because it does not require a storage position. An **s** usually does not contribute to the size of a numeric item, because by default **s** does not require a storage position.

However, if you plan to port your program or data to a different machine, you might want to code the sign for a zoned decimal data item as a separate position in storage. In the following case, the sign takes 1 byte:

```
05 Price Pic s99V99 Sign Is Leading, Separate.
```

This coding ensures that the convention your machine uses for storing a nonseparate sign will not cause unexpected results on a machine that uses a different convention.

Separate signs are also preferable for zoned decimal data items that will be printed or displayed.

Separate signs are required for national decimal data items that are signed. The sign takes 2 bytes of storage, as in the following example:

```
05 Price Pic s99V99 Usage National Sign Is Leading, Separate.
```

You cannot use the **PICTURE** clause with internal floating-point data (**COMP-1** or **COMP-2**). However, you can use the **VALUE** clause to provide an initial value for an internal floating-point literal:

```
05 Compute-result Usage Comp-2 Value 06.23E-24.
```

For information about external floating-point data, see the examples referenced below and the related concept about formats for numeric data.

“Examples: numeric data and internal representation” on page 51

RELATED CONCEPTS

“Formats for numeric data” on page 47

Appendix A, “Intermediate results and arithmetic precision,” on page 685

RELATED TASKS

“Displaying numeric data” on page 45

“Controlling how numeric data is stored” on page 46

“Performing arithmetic” on page 56

“Defining national numeric data items” on page 133

RELATED REFERENCES

“Sign representation of zoned and packed-decimal data” on page 53

“Storage of character data” on page 137

“ARITH” on page 309

“NUMPROC” on page 343

SIGN clause (*Enterprise COBOL Language Reference*)

Displaying numeric data

You can define numeric items with certain editing symbols (such as decimal points, commas, dollar signs, and debit or credit signs) to make the items easier to read and understand when you display or print them.

For example, in the code below, Edited-price is a numeric-edited item that has USAGE DISPLAY. (You can specify the clause USAGE IS DISPLAY for numeric-edited items; however, it is implied. It means that the items are stored in character format.)

```
05 Price          Pic    9(5)v99.
05 Edited-price   Pic   $zz,zz9.99.
. . .
Move Price To Edited-price
Display Edited-price
```

If the contents of Price are 0150099 (representing the value 1,500.99), \$ 1,500.99 is displayed when you run the code. The z in the PICTURE clause of Edited-price indicates the suppression of leading zeros.

You can define numeric-edited data items to hold national (UTF-16) characters instead of alphanumeric characters. To do so, define the numeric-edited items as USAGE NATIONAL. The effect of the editing symbols is the same for numeric-edited items that have USAGE NATIONAL as it is for numeric-edited items that have USAGE DISPLAY, except that the editing is done with national characters. For example, if Edited-price is declared as USAGE NATIONAL in the code above, the item is edited and displayed using national characters.

To display numeric or numeric-edited data items that have USAGE NATIONAL in EBCDIC, direct them to CONSOLE. For example, if Edited-price in the code above has USAGE NATIONAL, \$ 1,500.99 is displayed when you run the program if the last statement above is:

```
Display Edited-price Upon Console
```

You can cause an elementary numeric or numeric-edited item to be filled with spaces when a value of zero is stored into it by coding the BLANK WHEN ZERO clause for the item. For example, each of the DISPLAY statements below causes blanks to be displayed instead of zeros:

```
05 Price          Pic    9(5)v99.
05 Edited-price-D Pic   $99,999.99
                   Blank When Zero.
05 Edited-price-N Pic   $99,999.99 Usage National
                   Blank When Zero.
. . .
Move 0 to Price
Move Price to Edited-price-D
Move Price to Edited-price-N
Display Edited-price-D
Display Edited-price-N upon console
```

You cannot use numeric-edited items as sending operands in arithmetic expressions or in ADD, SUBTRACT, MULTIPLY, DIVIDE, or COMPUTE statements. (Numeric editing takes place when a numeric-edited item is the receiving field for one of these statements, or when a MOVE statement has a numeric-edited receiving field and a numeric-edited or numeric sending field.) You use numeric-edited items primarily for displaying or printing numeric data.

You can move numeric-edited items to numeric or numeric-edited items. In the following example, the value of the numeric-edited item (whether it has USAGE DISPLAY or USAGE NATIONAL) is moved to the numeric item:

```
Move Edited-price to Price  
Display Price
```

If these two statements immediately followed the statements in the first example above, then Price would be displayed as 0150099, representing the value 1,500.99. Price would also be displayed as 0150099 if Edited-price had USAGE NATIONAL.

You can also move numeric-edited items to alphanumeric, alphanumeric-edited, floating-point, and national data items. For a complete list of the valid receiving items for numeric-edited data, see the related reference about the MOVE statement.

“Examples: numeric data and internal representation” on page 51

RELATED TASKS

“Displaying values on a screen or in a file (DISPLAY)” on page 35

“Controlling how numeric data is stored”

“Defining numeric data” on page 43

“Performing arithmetic” on page 56

“Defining national numeric data items” on page 133

“Converting to or from national (Unicode) representation” on page 137

RELATED REFERENCES

MOVE statement (*Enterprise COBOL Language Reference*)

BLANK WHEN ZERO clause (*Enterprise COBOL Language Reference*)

Controlling how numeric data is stored

You can control how the computer stores numeric data items by coding the USAGE clause in your data description entries.

You might want to control the format for any of several reasons such as these:

- Arithmetic performed with computational data types is more efficient than with USAGE DISPLAY or USAGE NATIONAL data types.
- Packed-decimal format requires less storage per digit than USAGE DISPLAY or USAGE NATIONAL data types.
- Packed-decimal format converts to and from DISPLAY or NATIONAL format more efficiently than binary format does.
- Floating-point format is well suited for arithmetic operands and results with widely varying scale, while maintaining the maximal number of significant digits.
- You might need to preserve data formats when you move data from one machine to another.

The numeric data you use in your program will have one of the following formats available with COBOL:

- External decimal (USAGE DISPLAY or USAGE NATIONAL)
- External floating point (USAGE DISPLAY or USAGE NATIONAL)
- Internal decimal (USAGE PACKED-DECIMAL)
- Binary (USAGE BINARY)
- Native binary (USAGE COMP-5)

- Internal floating point (USAGE COMP-1 or USAGE COMP-2)

COMP and COMP-4 are synonymous with BINARY, and COMP-3 is synonymous with PACKED-DECIMAL.

The compiler converts displayable numbers to the internal representation of their numeric values before using them in arithmetic operations. Therefore it is often more efficient if you define data items as BINARY or PACKED-DECIMAL than as DISPLAY or NATIONAL. For example:

```
05 Initial-count Pic S9(4) Usage Binary Value 1000.
```

Regardless of which USAGE clause you use to control the internal representation of a value, you use the same PICTURE clause conventions and decimal value in the VALUE clause (except for internal floating-point data, for which you cannot use a PICTURE clause).

“Examples: numeric data and internal representation” on page 51

RELATED CONCEPTS

“Formats for numeric data”

“Data format conversions” on page 52

Appendix A, “Intermediate results and arithmetic precision,” on page 685

RELATED TASKS

“Defining numeric data” on page 43

“Displaying numeric data” on page 45

“Performing arithmetic” on page 56

RELATED REFERENCES

“Conversions and precision” on page 52

“Sign representation of zoned and packed-decimal data” on page 53

Formats for numeric data

Several formats are available for numeric data.

External decimal (DISPLAY and NATIONAL) items

When USAGE DISPLAY is in effect for a category numeric data item (either because you have coded it, or by default), each position (byte) of storage contains one decimal digit. The items are stored in displayable form. External decimal items that have USAGE DISPLAY are referred to as *zoned decimal* data items.

When USAGE NATIONAL is in effect for a category numeric data item, 2 bytes of storage are required for each decimal digit. The items are stored in UTF-16 format. External decimal items that have USAGE NATIONAL must only contain valid UTF-16 digits. If they do not, the data is illegal and the behaviour of the generated code is undefined. External decimal items that have USAGE NATIONAL are referred to as *national decimal* data items.

National decimal data items, if signed, must have the SIGN SEPARATE clause in effect. All other rules for zoned decimal items apply to national decimal items. You can use national decimal items anywhere that other category numeric data items can be used.

External decimal (both zoned decimal and national decimal) data items are primarily intended for receiving and sending numbers between your program and files, terminals, or printers. You can also use external decimal items as operands and receivers in arithmetic processing. However, if your program performs a lot of intensive arithmetic, and efficiency is a high priority, COBOL's computational numeric types might be a better choice for the data items used in the arithmetic.

External floating-point (DISPLAY and NATIONAL) items

When USAGE DISPLAY is in effect for a floating-point data item (either because you have coded it, or by default), each PICTURE character position (except for *v*, an implied decimal point, if used) takes 1 byte of storage. The items are stored in displayable form. External floating-point items that have USAGE DISPLAY are referred to as *display floating-point* data items in this information when necessary to distinguish them from external floating-point items that have USAGE NATIONAL.

In the following example, `Compute-Result` is implicitly defined as a display floating-point item:

```
05 Compute-Result Pic -9v9(9)E-99.
```

The minus signs (-) do not mean that the mantissa and exponent must necessarily be negative numbers. Instead, they mean that when the number is displayed, the sign appears as a blank for positive numbers or a minus sign for negative numbers. If you instead code a plus sign (+), the sign appears as a plus sign for positive numbers or a minus sign for negative numbers.

When USAGE NATIONAL is in effect for a floating-point data item, each PICTURE character position (except for *v*, if used) takes 2 bytes of storage. The items are stored as national characters (UTF-16). External floating-point items that have USAGE NATIONAL are referred to as *national floating-point* data items.

The existing rules for display floating-point items apply to national floating-point items.

In the following example, `Compute-Result-N` is a national floating-point item:

```
05 Compute-Result-N Pic -9v9(9)E-99 Usage National.
```

If `Compute-Result-N` is displayed, the signs appear as described above for `Compute-Result`, but in national characters. To instead display `Compute-Result-N` in EBCDIC characters, direct it to the console:

```
Display Compute-Result-N Upon Console
```

You cannot use the VALUE clause for external floating-point items.

As with external decimal numbers, external floating-point numbers have to be converted (by the compiler) to an internal representation of their numeric value before they can be used in arithmetic operations. If you compile with the default option ARITH (COMPAT), external floating-point numbers are converted to long (64-bit) floating-point format. If you compile with ARITH (EXTEND), they are instead converted to extended-precision (128-bit) floating-point format.

Binary (COMP) items

BINARY, COMP, and COMP-4 are synonyms. Binary-format numbers occupy 2, 4, or 8 bytes of storage. If the PICTURE clause specifies that an item is signed, the leftmost bit is used as the operational sign.

A binary number with a PICTURE description of four or fewer decimal digits occupies 2 bytes; five to nine decimal digits, 4 bytes; and 10 to 18 decimal digits, 8 bytes. Binary items with nine or more digits require more handling by the compiler. Testing them for the SIZE ERROR condition and rounding is more cumbersome than with other types.

You can use binary items, for example, for indexes, subscripts, switches, and arithmetic operands or results.

Use the TRUNC(STD|OPT|BIN) compiler option to indicate how binary data (BINARY, COMP, or COMP-4) is to be truncated.

Native binary (COMP-5) items

Data items that you define as USAGE COMP-5 are represented in storage as binary data. However, unlike USAGE COMP items, they can contain values of magnitude up to the capacity of the native binary representation (2, 4, or 8 bytes) rather than being limited to the value implied by the number of 9s in the PICTURE clause.

When you move or store numeric data into a COMP-5 item, truncation occurs at the binary field size rather than at the COBOL PICTURE size limit. When you reference a COMP-5 item, the full binary field size is used in the operation.

COMP-5 is thus particularly useful for binary data items that originate in non-COBOL programs where the data might not conform to a COBOL PICTURE clause.

The table below shows the ranges of possible values for COMP-5 data items.

Table 5. Ranges in value of COMP-5 data items

PICTURE	Storage representation	Numeric values
S9(1) through S9(4)	Binary halfword (2 bytes)	-32768 through +32767
S9(5) through S9(9)	Binary fullword (4 bytes)	-2,147,483,648 through +2,147,483,647
S9(10) through S9(18)	Binary doubleword (8 bytes)	-9,223,372,036,854,775,808 through +9,223,372,036,854,775,807
9(1) through 9(4)	Binary halfword (2 bytes)	0 through 65535
9(5) through 9(9)	Binary fullword (4 bytes)	0 through 4,294,967,295
9(10) through 9(18)	Binary doubleword (8 bytes)	0 through 18,446,744,073,709,551,615

You can specify scaling (that is, decimal positions or implied integer positions) in the PICTURE clause of COMP-5 items. If you do so, you must appropriately scale the maximal capacities listed above. For example, a data item you describe as PICTURE S99V99 COMP-5 is represented in storage as a binary halfword, and supports a range of values from -327.68 through +327.67.

Large literals in VALUE clauses: Literals specified in VALUE clauses for COMP-5 items can, with a few exceptions, contain values of magnitude up to the capacity of the native binary representation. See *Enterprise COBOL Language Reference* for the exceptions.

Regardless of the setting of the TRUNC compiler option, COMP-5 data items behave like binary data does in programs compiled with TRUNC(BIN).

Packed-decimal (COMP-3) items

PACKED-DECIMAL and COMP-3 are synonyms. Packed-decimal items occupy 1 byte of storage for every two decimal digits you code in the PICTURE description, except that the rightmost byte contains only one digit and the sign. This format is most efficient when you code an odd number of digits in the PICTURE description, so that the leftmost byte is fully used. Packed-decimal items are handled as fixed-point numbers for arithmetic purposes.

Internal floating-point (COMP-1 and COMP-2) items

COMP-1 refers to short floating-point format and COMP-2 refers to long floating-point format, which occupy 4 and 8 bytes of storage, respectively. The leftmost bit contains the sign and the next 7 bits contain the exponent; the remaining 3 or 7 bytes contain the mantissa.

COMP-1 and COMP-2 data items are stored in System z[®] hexadecimal format.

RELATED CONCEPTS

“Unicode and the encoding of language characters” on page 129

Appendix A, “Intermediate results and arithmetic precision,” on page 685

RELATED TASKS

“Defining numeric data” on page 43

“Defining national numeric data items” on page 133

RELATED REFERENCES

“Storage of character data” on page 137

“TRUNC” on page 368

Classes and categories of data (*Enterprise COBOL Language Reference*)

SIGN clause (*Enterprise COBOL Language Reference*)

VALUE clause (*Enterprise COBOL Language Reference*)

Examples: numeric data and internal representation

The following table shows the internal representation of numeric items.

Table 6. Internal representation of numeric items

Numeric type	PICTURE and USAGE and optional SIGN clause	Value	Internal representation
External decimal	PIC S9999 DISPLAY	+ 1234	F1 F2 F3 C4
		- 1234	F1 F2 F3 D4
		1234	F1 F2 F3 C4
	PIC 9999 DISPLAY	1234	F1 F2 F3 F4
	PIC 9999 NATIONAL	1234	00 31 00 32 00 33 00 34
	PIC S9999 DISPLAY SIGN LEADING	+ 1234	C1 F2 F3 F4
		- 1234	D1 F2 F3 F4
	PIC S9999 DISPLAY SIGN LEADING SEPARATE	+ 1234	4E F1 F2 F3 F4
		- 1234	60 F1 F2 F3 F4
	PIC S9999 DISPLAY SIGN TRAILING SEPARATE	+ 1234	F1 F2 F3 F4 4E
		- 1234	F1 F2 F3 F4 60
	PIC S9999 NATIONAL SIGN LEADING SEPARATE	+ 1234	00 2B 00 31 00 32 00 33 00 34
		- 1234	00 2D 00 31 00 32 00 33 00 34
	PIC S9999 NATIONAL SIGN TRAILING SEPARATE	+ 1234	00 31 00 32 00 33 00 34 00 2B
- 1234		00 31 00 32 00 33 00 34 00 2D	
Binary	PIC S9999 BINARY PIC S9999 COMP PIC S9999 COMP-4	+ 1234	04 D2
		- 1234	FB 2E
	PIC S9999 COMP-5	+ 12345 ¹	30 39
		- 12345 ¹	CF C7
	PIC 9999 BINARY PIC 9999 COMP PIC 9999 COMP-4	1234	04 D2
		PIC 9999 COMP-5	60000 ¹
Internal decimal	PIC S9999 PACKED-DECIMAL PIC S9999 COMP-3	+ 1234	01 23 4C
		- 1234	01 23 4D
	PIC 9999 PACKED-DECIMAL PIC 9999 COMP-3	1234	01 23 4F
Internal floating point	COMP-1	+ 1234	43 4D 20 00
		- 1234	C3 4D 20 00
	COMP-2	+ 1234	43 4D 20 00 00 00 00 00
		- 1234	C3 4D 20 00 00 00 00 00
External floating point	PIC +9(2).9(2)E+99 DISPLAY	+ 12.34E+02	4E F1 F2 4B F3 F4 C5 4E F0 F2
		- 12.34E+02	60 F1 F2 4B F3 F4 C5 4E F0 F2
	PIC +9(2).9(2)E+99 NATIONAL	+ 12.34E+02	00 2B 00 31 00 32 00 2E 00 33 00 34 00 45 00 2B 00 30 00 32
		- 12.34E+02	00 2D 00 31 00 32 00 2E 00 33 00 34 00 45 00 2B 00 30 00 32

Table 6. Internal representation of numeric items (continued)

Numeric type	PICTURE and USAGE and optional SIGN clause	Value	Internal representation
<p>1. The example demonstrates that COMP-5 data items can contain values of magnitude up to the capacity of the native binary representation (2, 4, or 8 bytes), rather than being limited to the value implied by the number of 9s in the PICTURE clause.</p>			

Data format conversions

When the code in your program involves the interaction of items that have different data formats, the compiler converts those items either temporarily, for comparisons and arithmetic operations, or permanently, for assignment to the receiver in a MOVE or COMPUTE statement.

A conversion is actually a move of a value from one data item to another. The compiler performs any conversions that are required during the execution of arithmetic or comparisons by using the same rules that are used for MOVE and COMPUTE statements.

When possible, the compiler performs a move to preserve numeric value instead of a direct digit-for-digit move.

Conversion generally requires additional storage and processing time because data is moved to an internal work area and converted before the operation is performed. The results might also have to be moved back into a work area and converted again.

Conversions between fixed-point data formats (external decimal, packed decimal, or binary) are without loss of precision provided that the target field can contain all the digits of the source operand.

A loss of precision is possible in conversions between fixed-point data formats and floating-point data formats (short floating point, long floating point, or external floating point). These conversions happen during arithmetic evaluations that have a mixture of both fixed-point and floating-point operands.

RELATED REFERENCES

“Conversions and precision”

“Sign representation of zoned and packed-decimal data” on page 53

Conversions and precision

In some numeric conversions, a loss of precision is possible; other conversions preserve precision or result in rounding.

Because both fixed-point and external floating-point items have decimal characteristics, references to fixed-point items in the following examples include external floating-point items unless stated otherwise.

When the compiler converts from fixed-point to internal floating-point format, fixed-point numbers in base 10 are converted to the numbering system used internally.

When the compiler converts short form to long form for comparisons, zeros are used for padding the shorter number.

Conversions that lose precision

When a USAGE COMP-1 data item is moved to a fixed-point data item that has more than nine digits, the fixed-point data item will receive only nine significant digits, and the remaining digits will be zero.

When a USAGE COMP-2 data item is moved to a fixed-point data item that has more than 18 digits, the fixed-point data item will receive only 18 significant digits, and the remaining digits will be zero.

Conversions that preserve precision

If a fixed-point data item that has six or fewer digits is moved to a USAGE COMP-1 data item and then returned to the fixed-point data item, the original value is recovered.

If a USAGE COMP-1 data item is moved to a fixed-point data item of nine or more digits and then returned to the USAGE COMP-1 data item, the original value is recovered.

If a fixed-point data item that has 15 or fewer digits is moved to a USAGE COMP-2 data item and then returned to the fixed-point data item, the original value is recovered.

If a USAGE COMP-2 data item is moved to a fixed-point (not external floating-point) data item of 18 or more digits and then returned to the USAGE COMP-2 data item, the original value is recovered.

Conversions that result in rounding

If a USAGE COMP-1 data item, a USAGE COMP-2 data item, an external floating-point data item, or a floating-point literal is moved to a fixed-point data item, rounding occurs in the low-order position of the target data item.

If a USAGE COMP-2 data item is moved to a USAGE COMP-1 data item, rounding occurs in the low-order position of the target data item.

If a fixed-point data item is moved to an external floating-point data item and the PICTURE of the fixed-point data item contains more digit positions than the PICTURE of the external floating-point data item, rounding occurs in the low-order position of the target data item.

RELATED CONCEPTS

Appendix A, "Intermediate results and arithmetic precision," on page 685

Sign representation of zoned and packed-decimal data

Sign representation affects the processing and interaction of zoned decimal and internal decimal data.

Given $X'sd'$, where s is the sign representation and d represents the digit, the valid sign representations for zoned decimal (USAGE DISPLAY) data without the SIGN IS SEPARATE clause are:

Positive:

C, A, E, and F

Negative:

D and B

The COBOL NUMPROC compiler option affects sign processing for zoned decimal and internal decimal data. NUMPROC has no effect on binary data, national decimal data, or floating-point data.

NUMPROC(PFD)

Given $X'sd'$, where s is the sign representation and d represents the digit, when you use NUMPROC(PFD), the compiler assumes that the sign in your data is one of three preferred signs:

Signed positive or 0:

$X'C'$

Signed negative:

$X'D'$

Unsigned or alphanumeric:

$X'F'$

Based on this assumption, the compiler uses whatever sign it is given to process data. The preferred sign is generated only where necessary (for example, when unsigned data is moved to signed data). Using the NUMPROC(PFD) option can save processing time, but you must use preferred signs with your data for correct processing.

NUMPROC(NOPFD)

When the NUMPROC(NOPFD) compiler option is in effect, the compiler accepts any valid sign configuration. The preferred sign is always generated in the receiver. NUMPROC(NOPFD) is less efficient than NUMPROC(PFD), but you should use it whenever data that does not use preferred signs might exist.

If an unsigned, zoned-decimal sender is moved to an alphanumeric receiver, the sign is unchanged (even with NUMPROC(NOPFD) in effect).

RELATED REFERENCES

"NUMPROC" on page 343

"ZWB" on page 379

Checking for incompatible data (numeric class test)

The compiler assumes that values you supply for a data item are valid for the PICTURE and USAGE clauses, and does not check their validity. Ensure that the contents of a data item conform to the PICTURE and USAGE clauses before using the item in additional processing.

It can happen that values are passed into your program and assigned to items that have incompatible data descriptions for those values. For example, nonnumeric data might be moved or passed into a field that is defined as numeric, or a signed number might be passed into a field that is defined as unsigned. In either case, the receiving fields contain invalid data. When you give an item a value that is incompatible with its data description, references to that item in the PROCEDURE DIVISION are undefined and your results are unpredictable.

You can use the numeric class test to perform data validation. For example:

Linkage Section.

```
01 Count-x Pic 999.
```

```
. . .
```

Procedure Division Using Count-x.

```
    If Count-x is numeric then display "Data is good"
```

The numeric class test checks the contents of a data item against a set of values that are valid for the PICTURE and USAGE of the data item. For example, a packed-decimal item is checked for hexadecimal values X'0' through X'9' in the digit positions and for a valid sign value in the sign position (whether separate or nonseparate). An external decimal data item that has USAGE DISPLAY is checked for hexadecimal values X'0' through X'9' in the digit positions (the lower 4 bits of each byte), for a valid zone code in the upper 4 bits of each byte and for a valid sign value in the sign position (whether separate or nonseparate). The sign code is in the upper 4 bits of the sign byte or in a separate byte if SIGN IS SEPARATE was specified. If the SIGN IS SEPARATE clause is used, the upper four bits of all bytes must be x'F'.

Note: Although the ZONEDATA(MIG|NOPFD) compiler option allows toleration of invalid zone codes in USAGE DISPLAY numeric (zoned decimal) data items in numeric comparisons, invalid zone codes in zoned decimal data items will be treated as nonnumeric by the numeric class test.

For zoned decimal and packed-decimal items, the numeric class test is affected by the NUMPROC compiler option and the NUMCLS option (which is set at installation time). To determine the NUMCLS setting used at your installation, consult your system programmer.

If NUMCLS(PRIM) is in effect at your installation, use the following table to find the values that the compiler considers valid for the sign.

Table 7. NUMCLS(PRIM) and valid signs

	NUMPROC (NOPFD)	NUMPROC (PFD)
Signed	C, D, F	C, D, +0 (positive zero)
Unsigned	F	F
Separate sign	+, -	+, -, +0 (positive zero)

If NUMCLS(ALT) is in effect at your installation, use the following table to find the values that the compiler considers valid for the sign.

Table 8. NUMCLS(ALT) and valid signs

	NUMPROC (NOPFD)	NUMPROC (PFD)
Signed	A to F	C, D, +0 (positive zero)
Unsigned	F	F
Separate sign	+, -	+, -, +0 (positive zero)

You can also use the NUMCHECK(ZON,PAC) option to have the compiler generate implicit numeric class tests for zoned decimal (numeric USAGE DISPLAY) and packed decimal (COMP-3) data items that are used as sending data items. This numeric class test validates data and also validates sign fields against the NUMPROC compiler option to help you decide whether you can use NUMPROC(PFD) or not. For details, see "NUMCHECK" on page 341.

RELATED REFERENCES

- "NUMCHECK" on page 341
- "NUMPROC" on page 343
- "ZONECHECK" on page 375
- "ZONEDATA" on page 377

Performing arithmetic

You can use any of several COBOL language features (including COMPUTE, arithmetic expressions, numeric intrinsic functions, and math and date callable services) to perform arithmetic. Your choice depends on whether a feature meets your particular needs.

For most common arithmetic evaluations, the COMPUTE statement is appropriate. If you need to use numeric literals, numeric data, or arithmetic operators, you might want to use arithmetic expressions. In places where numeric expressions are allowed, you can save time by using numeric intrinsic functions. Language Environment callable services for mathematical functions and for date and time operations also provide a means of assigning arithmetic results to data items.

RELATED TASKS

“Using COMPUTE and other arithmetic statements”

“Using arithmetic expressions” on page 57

“Using numeric intrinsic functions” on page 57

“Using math-oriented callable services” on page 59

“Using date callable services” on page 60

Using COMPUTE and other arithmetic statements

Use the COMPUTE statement for most arithmetic evaluations rather than ADD, SUBTRACT, MULTIPLY, and DIVIDE statements. Often you can code only one COMPUTE statement instead of several individual arithmetic statements.

The COMPUTE statement assigns the result of an arithmetic expression to one or more data items:

```
Compute z      = a + b / c ** d - e
Compute x y z = a + b / c ** d - e
```

Some arithmetic calculations might be more intuitive using arithmetic statements other than COMPUTE. For example:

COMPUTE	Equivalent arithmetic statements
Compute Increment = Increment + 1	Add 1 to Increment
Compute Balance = Balance - Overdraft	Subtract Overdraft from Balance
Compute IncrementOne = IncrementOne + 1 Compute IncrementTwo = IncrementTwo + 1 Compute IncrementThree = IncrementThree + 1	Add 1 to IncrementOne, IncrementTwo, IncrementThree

You might also prefer to use the DIVIDE statement (with its REMAINDER phrase) for division in which you want to process a remainder. The REM intrinsic function also provides the ability to process a remainder.

When you perform arithmetic calculations, you can use national decimal data items as operands just as you use zoned decimal data items. You can also use national floating-point data items as operands just as you use display floating-point operands.

RELATED CONCEPTS

“Fixed-point contrasted with floating-point arithmetic” on page 62
Appendix A, “Intermediate results and arithmetic precision,” on page 685

RELATED TASKS

“Defining numeric data” on page 43

Using arithmetic expressions

You can use arithmetic expressions in many (but not all) places in statements where numeric data items are allowed.

For example, you can use arithmetic expressions as comparands in relation conditions:

If $(a + b) > (c - d + 5)$ Then. . .

Arithmetic expressions can consist of a single numeric literal, a single numeric data item, or a single intrinsic function reference. They can also consist of several of these items connected by arithmetic operators.

Arithmetic operators are evaluated in the following order of precedence:

Table 9. Order of evaluation of arithmetic operators

Operator	Meaning	Order of evaluation
Unary + or -	Algebraic sign	First
**	Exponentiation	Second
/ or *	Division or multiplication	Third
Binary + or -	Addition or subtraction	Last

Operators at the same level of precedence are evaluated from left to right; however, you can use parentheses to change the order of evaluation. Expressions in parentheses are evaluated before the individual operators are evaluated. Parentheses, whether necessary or not, make your program easier to read.

RELATED CONCEPTS

“Fixed-point contrasted with floating-point arithmetic” on page 62
Appendix A, “Intermediate results and arithmetic precision,” on page 685

Using numeric intrinsic functions

You can use numeric intrinsic functions only in places where numeric expressions are allowed. These functions can save you time because you don't have to code the many common types of calculations that they provide.

Numeric intrinsic functions return a signed numeric value, and are treated as temporary numeric data items.

Numeric functions are classified into the following categories:

Integer

Those that return an integer

Floating point

Those that return a long (64-bit) or extended-precision (128-bit) floating-point value (depending on whether you compile using the default option `ARITH(COMPAT)` or using `ARITH(EXTEND)`)

Mixed

Those that return an integer, a floating-point value, or a fixed-point number with decimal places, depending on the arguments

You can use intrinsic functions to perform several different arithmetic operations, as outlined in the following table.

Table 10. Numeric intrinsic functions

Number handling	Date and time	Finance	Mathematics	Statistics
LENGTH MAX MIN NUMVAL NUMVAL-C ORD-MAX ORD-MIN	CURRENT-DATE DATE-OF-INTEGER DATE-TO-YYYYMMDD DAY-OF-INTEGER DAY-TO-YYYYDDD INTEGER-OF-DATE INTEGER-OF-DAY WHEN-COMPILED YEAR-TO-YYYY	ANNUITY PRESENT-VALUE	ACOS ASIN ATAN COS FACTORIAL INTEGER INTEGER-PART LOG LOG10 MOD REM SIN SQRT SUM TAN	MEAN MEDIAN MIDRANGE RANDOM RANGE STANDARD-DEVIATION VARIANCE

“Examples: numeric intrinsic functions” on page 60

You can reference one function as the argument of another. A nested function is evaluated independently of the outer function (except when the compiler determines whether a mixed function should be evaluated using fixed-point or floating-point instructions).

You can also nest an arithmetic expression as an argument to a numeric function. For example, in the statement below, there are three function arguments (a, b, and the arithmetic expression (c / d)):

```
Compute x = Function Sum(a b (c / d))
```

You can reference all the elements of a table (or array) as function arguments by using the ALL subscript.

You can also use the integer special registers as arguments wherever integer arguments are allowed.

Many of the capabilities of numeric intrinsic functions are also provided by Language Environment callable services.

RELATED CONCEPTS

“Fixed-point contrasted with floating-point arithmetic” on page 62

Appendix A, “Intermediate results and arithmetic precision,” on page 685

RELATED REFERENCES

“ARITH” on page 309

Using math-oriented callable services

Most COBOL intrinsic functions have corresponding math-oriented callable services that you can use to produce the same results.

When you compile with the default option `ARITH(COMPAT)`, COBOL floating-point intrinsic functions return long (64-bit) results. When you compile with option `ARITH(EXTEND)`, COBOL floating-point intrinsic functions (with the exception of `RANDOM`) return extended-precision (128-bit) results.

For example (considering the first row of the table below), if you compile using `ARITH(COMPAT)`, `CEESDACS` returns the same result as `ACOS`. If you compile using `ARITH(EXTEND)`, `CEESQACS` returns the same result as `ACOS`.

Table 11. Compatibility of math intrinsic functions and callable services

COBOL intrinsic function	Corresponding long-precision Language Environment callable service	Corresponding extended-precision Language Environment callable service	Results same for intrinsic function and callable service?
ACOS	CEESDACS	CEESQACS	Yes
ASIN	CEESDASN	CEESQASN	Yes
ATAN	CEESDATN	CEESQATN	Yes
COS	CEESDCOS	CEESQCOS	Yes
LOG	CEESDLOG	CEESQLOG	Yes
LOG10	CEESDLG1	CEESQLG1	Yes
RANDOM ¹	CEERAN0	none	No
REM	CEESDMOD	CEESQMOD	Yes
SIN	CEESDSIN	CEESQSIN	Yes
SQRT	CEESDSQT	CEESQSQT	Yes
TAN	CEESDTAN	CEESQTAN	Yes

1. `RANDOM` returns a long (64-bit) floating-point result even if you pass it a 31-digit argument and compile with `ARITH(EXTEND)`.

Both the `RANDOM` intrinsic function and `CEERAN0` service generate random numbers between zero and one. However, because each uses its own algorithm, `RANDOM` and `CEERAN0` produce different random numbers from the same seed.

Even for functions that produce the same results, how you use intrinsic functions and Language Environment callable services differs. The rules for the data types required for intrinsic function arguments are less restrictive. For numeric intrinsic functions, you can use arguments that are of any numeric data type. When you invoke a Language Environment callable service with a `CALL` statement, however, you must ensure that the parameters match the numeric data types (generally `COMP-1` or `COMP-2`) required by that service.

The error handling of intrinsic functions and Language Environment callable services sometimes differs. If you pass an explicit feedback token when calling the Language Environment math services, you must check the feedback code after each call and take explicit action to deal with errors. However, if you call with the feedback token explicitly `OMITTED`, you do not need to check the token; Language Environment automatically signals any errors.

RELATED CONCEPTS

“Fixed-point contrasted with floating-point arithmetic” on page 62
Appendix A, “Intermediate results and arithmetic precision,” on page 685

RELATED TASKS

“Using Language Environment callable services” on page 677

RELATED REFERENCES

“ARITH” on page 309

Using date callable services

Both the COBOL date intrinsic functions and the Language Environment date callable services are based on the Gregorian calendar. However, the starting dates can differ depending on the setting of the INTDATE compiler option.

When INTDATE(LILIAN) is in effect, COBOL uses October 15, 1582 as day 1. Language Environment always uses October 15, 1582 as day 1. If you use INTDATE(LILIAN), you get equivalent results from COBOL intrinsic functions and Language Environment date callable services. The following table compares the results when INTDATE(LILIAN) is in effect.

Table 12. INTDATE(LILIAN) and compatibility of date intrinsic functions and callable services

COBOL intrinsic function	Language Environment callable service	Results
DATE-OF-INTEGERS	CEEDATE with picture string YYYYMMDD	Compatible
DAY-OF-INTEGERS	CEEDATE with picture string YYYYDDD	Compatible
INTEGER-OF-DATE	CEEDAYS	Compatible
INTEGER-OF-DATE	CEECBLDY	Incompatible

When the default setting of INTDATE(ANSI) is in effect, COBOL uses January 1, 1601 as day 1. The following table compares the results when INTDATE(ANSI) is in effect.

Table 13. INTDATE(ANSI) and compatibility of date intrinsic functions and callable services

COBOL intrinsic function	Language Environment callable service	Results
INTEGER-OF-DATE	CEECBLDY	Compatible
DATE-OF-INTEGERS	CEEDATE with picture string YYYYMMDD	Incompatible
DAY-OF-INTEGERS	CEEDATE with picture string YYYYDDD	Incompatible
INTEGER-OF-DATE	CEEDAYS	Incompatible

RELATED TASKS

“Using Language Environment callable services” on page 677

RELATED REFERENCES

“INTDATE” on page 332

Examples: numeric intrinsic functions

The following examples and accompanying explanations show intrinsic functions in each of several categories.

Where the examples below show zoned decimal data items, national decimal items could instead be used. (Signed national decimal items, however, require that the SIGN SEPARATE clause be in effect.)

General number handling

Suppose you want to find the maximum value of two prices (represented below as alphanumeric items with dollar signs), put this value into a numeric field in an output record, and determine the length of the output record. You can use NUMVAL-C (a function that returns the numeric value of an alphanumeric or national literal, or an alphanumeric or national data item) and the MAX and LENGTH functions to do so:

```
01 X                Pic 9(2).
01 Price1           Pic x(8)  Value "$8000".
01 Price2           Pic x(8)  Value "$2000".
01 Output-Record.
   05 Product-Name  Pic x(20).
   05 Product-Number Pic 9(9).
   05 Product-Price Pic 9(6).
. . .
Procedure Division.
   Compute Product-Price =
      Function Max (Function Numval-C(Price1) Function Numval-C(Price2))
   Compute X = Function Length(Output-Record)
```

Additionally, to ensure that the contents in Product-Name are in uppercase letters, you can use the following statement:

```
Move Function Upper-case (Product-Name) to Product-Name
```

Date and time

The following example shows how to calculate a due date that is 90 days from today. The first eight characters returned by the CURRENT-DATE function represent the date in a four-digit year, two-digit month, and two-digit day format (YYYYMMDD). The date is converted to its integer value; then 90 is added to this value and the integer is converted back to the YYYYMMDD format.

```
01 YYYYMMDD        Pic 9(8).
01 Integer-Form     Pic S9(9).
. . .
   Move Function Current-Date(1:8) to YYYYMMDD
   Compute Integer-Form = Function Integer-of-Date(YYYYMMDD)
   Add 90 to Integer-Form
   Compute YYYYMMDD = Function Date-of-Integer(Integer-Form)
   Display 'Due Date: ' YYYYMMDD
```

Finance

Business investment decisions frequently require computing the present value of expected future cash inflows to evaluate the profitability of a planned investment. The present value of an amount that you expect to receive at a given time in the future is that amount, which, if invested today at a given interest rate, would accumulate to that future amount.

For example, assume that a proposed investment of \$1,000 produces a payment stream of \$100, \$200, and \$300 over the next three years, one payment per year respectively. The following COBOL statements calculate the present value of those cash inflows at a 10% interest rate:

```
01 Series-Amt1      Pic 9(9)V99      Value 100.
01 Series-Amt2      Pic 9(9)V99      Value 200.
01 Series-Amt3      Pic 9(9)V99      Value 300.
01 Discount-Rate    Pic S9(2)V9(6)   Value .10.
01 Todays-Value     Pic 9(9)V99.
```

```

. . .
Compute Todays-Value =
Function
Present-Value(Discount-Rate Series-Amt1 Series-Amt2 Series-Amt3)

```

You can use the ANNUITY function in business problems that require you to determine the amount of an installment payment (annuity) necessary to repay the principal and interest of a loan. The series of payments is characterized by an equal amount each period, periods of equal length, and an equal interest rate each period. The following example shows how you can calculate the monthly payment required to repay a \$15,000 loan in three years at a 12% annual interest rate (36 monthly payments, interest per month = .12/12):

```

01 Loan          Pic 9(9)V99.
01 Payment       Pic 9(9)V99.
01 Interest      Pic 9(9)V99.
01 Number-Periods Pic 99.
. . .
Compute Loan = 15000
Compute Interest = .12
Compute Number-Periods = 36
Compute Payment =
Loan * Function Annuity((Interest / 12) Number-Periods)

```

Mathematics

The following COBOL statement demonstrates that you can nest intrinsic functions, use arithmetic expressions as arguments, and perform previously complex calculations simply:

```

Compute Z = Function Log(Function Sqrt (2 * X + 1)) + Function Rem(X 2)

```

Here in the addend the intrinsic function REM (instead of a DIVIDE statement with a REMAINDER clause) returns the remainder of dividing X by 2.

Statistics

Intrinsic functions make calculating statistical information easier. Assume you are analyzing various city taxes and want to calculate the mean, median, and range (the difference between the maximum and minimum taxes):

```

01 Tax-S          Pic 99v999 value .045.
01 Tax-T          Pic 99v999 value .02.
01 Tax-W          Pic 99v999 value .035.
01 Tax-B          Pic 99v999 value .03.
01 Ave-Tax        Pic 99v999.
01 Median-Tax     Pic 99v999.
01 Tax-Range      Pic 99v999.
. . .
Compute Ave-Tax   = Function Mean (Tax-S Tax-T Tax-W Tax-B)
Compute Median-Tax = Function Median (Tax-S Tax-T Tax-W Tax-B)
Compute Tax-Range = Function Range (Tax-S Tax-T Tax-W Tax-B)

```

RELATED TASKS

“Converting to numbers (NUMVAL, NUMVAL-C)” on page 117

Fixed-point contrasted with floating-point arithmetic

How you code arithmetic in a program (whether an arithmetic statement, an intrinsic function, an expression, or some combination of these nested within each other) determines whether the evaluation is done with floating-point or fixed-point arithmetic.

Many statements in a program could involve arithmetic. For example, each of the following types of COBOL statements requires some arithmetic evaluation:

- General arithmetic

```
compute report-matrix-col = (emp-count ** .5) + 1
add report-matrix-min to report-matrix-max giving report-matrix-tot
```

- Expressions and functions

```
compute report-matrix-col = function sqrt(emp-count) + 1
compute whole-hours      = function integer-part((average-hours) + 1)
```

- Arithmetic comparisons

```
if report-matrix-col <      function sqrt(emp-count) + 1
if whole-hours             not = function integer-part((average-hours) + 1)
```

Floating-point evaluations

In general, if your arithmetic coding has either of the characteristics listed below, it is evaluated in floating-point arithmetic:

- An operand or result field is floating point.

An operand is floating point if you code it as a floating-point literal or if you code it as a data item that is defined as USAGE COMP-1, USAGE COMP-2, or external floating point (USAGE DISPLAY or USAGE NATIONAL with a floating-point PICTURE).

An operand that is a nested arithmetic expression or a reference to a numeric intrinsic function results in floating-point arithmetic when any of the following conditions is true:

- An argument in an arithmetic expression results in floating point.
- The function is a floating-point function.
- The function is a mixed function with one or more floating-point arguments.

- An exponent contains decimal places.

An exponent contains decimal places if you use a literal that contains decimal places, give the item a PICTURE that contains decimal places, or use an arithmetic expression or function whose result has decimal places.

An arithmetic expression or numeric function yields a result that has decimal places if any operand or argument (excluding divisors and exponents) has decimal places.

Fixed-point evaluations

In general, if an arithmetic operation contains neither of the characteristics listed above for floating point, the compiler causes it to be evaluated in fixed-point arithmetic. In other words, arithmetic evaluations are handled as fixed point only if all the operands are fixed point, the result field is defined to be fixed point, and none of the exponents represent values with decimal places. Nested arithmetic expressions and function references must also represent fixed-point values.

Arithmetic comparisons (relation conditions)

When you compare numeric expressions using a relational operator, the numeric expressions (whether they are data items, arithmetic expressions, function references, or some combination of these) are comparands in the context of the entire evaluation. That is, the attributes of each can influence the evaluation of the other: both expressions are evaluated in fixed point, or both are evaluated in floating point. This is also true of abbreviated comparisons even though one comparand does not explicitly appear in the comparison. For example:

```
if (a + d) = (b + e) and c
```

This statement has two comparisons: $(a + d) = (b + e)$, and $(a + d) = c$. Although $(a + d)$ does not explicitly appear in the second comparison, it is a comparand in that comparison. Therefore, the attributes of c can influence the evaluation of $(a + d)$.

The compiler handles comparisons (and the evaluation of any arithmetic expressions nested in comparisons) in floating-point arithmetic if either comparand is a floating-point value or resolves to a floating-point value.

The compiler handles comparisons (and the evaluation of any arithmetic expressions nested in comparisons) in fixed-point arithmetic if both comparands are fixed-point values or resolve to fixed-point values.

Implicit comparisons (no relational operator used) are not handled as a unit, however; the two comparands are treated separately as to their evaluation in floating-point or fixed-point arithmetic. In the following example, five arithmetic expressions are evaluated independently of one another's attributes, and then are compared to each other.

```
evaluate (a + d)
    when (b + e) thru c
    when (f / g) thru (h * i)
    . . .
end-evaluate
```

"Examples: fixed-point and floating-point evaluations"

RELATED REFERENCES

"Arithmetic expressions in nonarithmetic statements" on page 693

Examples: fixed-point and floating-point evaluations

The following example shows statements that are evaluated using fixed-point arithmetic and using floating-point arithmetic.

Assume that you define the data items for an employee table in the following manner:

```
01 employee-table.
    05 emp-count          pic 9(4).
    05 employee-record occurs 1 to 1000 times
        depending on emp-count.
        10 hours          pic +9(5)ve+99.
    . . .
01 report-matrix-col     pic 9(3).
01 report-matrix-min     pic 9(3).
01 report-matrix-max     pic 9(3).
01 report-matrix-tot     pic 9(3).
01 average-hours        pic 9(3)v9.
01 whole-hours          pic 9(4).
```

These statements are evaluated using floating-point arithmetic:

```
compute report-matrix-col = (emp-count ** .5) + 1
compute report-matrix-col = function sqrt(emp-count) + 1
if report-matrix-tot < function sqrt(emp-count) + 1
```

These statements are evaluated using fixed-point arithmetic:

```
add report-matrix-min to report-matrix-max giving report-matrix-tot
compute report-matrix-max =
    function max(report-matrix-max report-matrix-tot)
if whole-hours not = function integer-part((average-hours) + 1)
```

Using currency signs

Many programs need to process financial information and present that information using the appropriate currency signs. With COBOL currency support (and the appropriate code page for your printer or display unit), you can use several currency signs in a program.

You can use one or more of the following signs:

- Symbols such as the dollar sign (\$)
- Currency signs of more than one character (such as USD or EUR)
- Euro sign, established by the Economic and Monetary Union (EMU)

To specify the symbols for displaying financial information, use the CURRENCY SIGN clause (in the SPECIAL-NAMES paragraph in the CONFIGURATION SECTION) with the PICTURE characters that relate to those symbols. In the following example, the PICTURE character \$ indicates that the currency sign \$US is to be used:

```
Currency Sign is "$US" with Picture Symbol "$".  
77 Invoice-Amount      Pic $$,$$9.99.  
  . . .  
  . . .  
  Display "Invoice amount is " Invoice-Amount.
```

In this example, if Invoice-Amount contained 1500.00, the display output would be:
Invoice amount is \$US1,500.00

By using more than one CURRENCY SIGN clause in your program, you can allow for multiple currency signs to be displayed.

You can use a hexadecimal literal to indicate the currency sign value. Using a hexadecimal literal could be useful if the data-entry method for the source program does not allow the entry of the intended characters easily. The following example shows the hexadecimal value X'9F' used as the currency sign:

```
Currency Sign X'9F' with Picture Symbol 'U'.  
01 Deposit-Amount      Pic UUUUU9.99.
```

If there is no corresponding character for the euro sign on your keyboard, you need to specify it as a hexadecimal value in the CURRENCY SIGN clause. The hexadecimal value for the euro sign is either X'9F' or X'5A' depending on the code page in use, as shown in the following table.

Table 14. Hexadecimal values of the euro sign

Code page CCSID	Applicable countries	Modified from	Euro sign
1140	USA, Canada, Netherlands, Portugal, Australia, New Zealand	037	X'9F'
1141	Austria, Germany	273	X'9F'
1142	Denmark, Norway	277	X'5A'
1143	Finland, Sweden	278	X'5A'
1144	Italy	280	X'9F'
1145	Spain, Latin America - Spanish	284	X'9F'
1146	UK	285	X'9F'
1147	France	297	X'9F'

Table 14. Hexadecimal values of the euro sign (continued)

Code page CCSID	Applicable countries	Modified from	Euro sign
1148	Belgium, Canada, Switzerland	500	X'9F'
1149	Iceland	871	X'9F'

RELATED REFERENCES

“CURRENCY” on page 317

CURRENCY SIGN clause (*Enterprise COBOL Language Reference*)

Example: multiple currency signs

The following example shows how you can display values in both euro currency (as EUR) and Swiss francs (as CHF).

```
IDENTIFICATION DIVISION.
PROGRAM-ID. EuroSamp.
Environment Division.
Configuration Section.
Special-Names.
    Currency Sign is "CHF " with Picture Symbol "F"
    Currency Sign is "EUR " with Picture Symbol "U".
Data Division.
WORKING-STORAGE SECTION.
01 Deposit-in-Euro          Pic S9999V99 Value 8000.00.
01 Deposit-in-CHF          Pic S99999V99.
01 Deposit-Report.
    02 Report-in-Franc     Pic -FFFFFF9.99.
    02 Report-in-Euro      Pic -UUUUU9.99.
01 EUR-to-CHF-Conv-Rate    Pic 9V99999 Value 1.53893.
.
.
.
PROCEDURE DIVISION.
Report-Deposit-in-CHF-and-EUR.
    Move Deposit-in-Euro to Report-in-Euro
    Compute Deposit-in-CHF Rounded
        = Deposit-in-Euro * EUR-to-CHF-Conv-Rate
    On Size Error
        Perform Conversion-Error
    Not On Size Error
        Move Deposit-in-CHF to Report-in-Franc
        Display "Deposit in euro = " Report-in-Euro
        Display "Deposit in franc = " Report-in-Franc
    End-Compute
    Goback.
Conversion-Error.
    Display "Conversion error from EUR to CHF"
    Display "Euro value: " Report-in-Euro.
```

The above example produces the following display output:

```
Deposit in euro = EUR 8000.00
Deposit in franc = CHF 12311.44
```

The exchange rate used in this example is for illustrative purposes only.

Chapter 4. Handling tables

A *table* is a collection of data items that have the same description, such as account totals or monthly averages. A table consists of a table name and subordinate items called *table elements*. A table is the COBOL equivalent of an array.

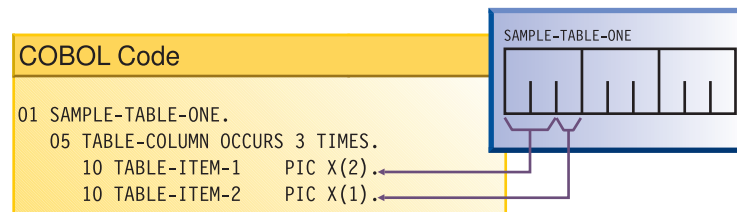

In the example above, SAMPLE-TABLE-ONE is the group item that contains the table. TABLE-COLUMN names the table element of a one-dimensional table that occurs three times.

Rather than defining repetitious items as separate, consecutive entries in the DATA DIVISION, you use the OCCURS clause in the DATA DIVISION entry to define a table. This practice has these advantages:

- The code clearly shows the unity of the items (the table elements).
- You can use subscripts and indexes to refer to the table elements.
- You can easily repeat data items.

Tables are important for increasing the speed of a program, especially a program that looks up records.

RELATED CONCEPTS

“Complex OCCURS DEPENDING ON” on page 81

RELATED TASKS

“Defining a table (OCCURS)”

“Nesting tables” on page 69

“Referring to an item in a table” on page 70

“Putting values into a table” on page 73

“Creating variable-length tables (DEPENDING ON)” on page 78

“Searching a table” on page 85

“Sorting a table” on page 88

“Processing table items using intrinsic functions” on page 89

“Working with unbounded tables and groups” on page 90

“Handling tables efficiently” on page 664

Defining a table (OCCURS)

To code a table, give the table a group name and define a subordinate item (the table element) to be repeated *n* times.

```
01 table-name.
   05 element-name OCCURS n TIMES.
      . . . (subordinate items of the table element)
```

In the example above, table-name is the name of an alphanumeric group item. The table element definition (which includes the OCCURS clause) is subordinate to the group item that contains the table. The OCCURS clause cannot be used in a level-01 description.

If a table is to contain only Unicode (UTF-16) data, and you want the group item that contains the table to behave like an elementary category national item in most operations, code the GROUP-USAGE NATIONAL clause for the group item:

```
01 table-nameN Group-Usage National.  
   05 element-nameN OCCURS m TIMES.  
     10 elementN1 Pic nn.  
     10 elementN2 Pic S99 Sign Is Leading, Separate.  
     . . .
```

Any elementary item that is subordinate to a national group must be explicitly or implicitly described as USAGE NATIONAL, and any subordinate numeric data item that is signed must be implicitly or explicitly described with the SIGN IS SEPARATE clause.

To create tables of two to seven dimensions, use nested OCCURS clauses.

To create a variable-length table, code the DEPENDING ON phrase of the OCCURS clause.

To specify that table elements will be arranged in ascending or descending order based on the values in one or more key fields of the table, code the ASCENDING or DESCENDING KEY phrases of the OCCURS clause, or both. Specify the names of the keys in decreasing order of significance. Keys can be of class alphabetic, alphanumeric, DBCS, national, or numeric. (If it has USAGE NATIONAL, a key can be of category national, or can be a national-edited, numeric-edited, national decimal, or national floating-point item.)

You must code the ASCENDING or DESCENDING KEY phrase of the OCCURS clause to do a binary search (SEARCH ALL) of a table. You can use a format 2 SORT statement to order the table according to its defined keys, thereby making the table searchable by the SEARCH ALL statement. Note that SEARCH ALL will return unpredictable results if the table has not been ordered according to the keys.

“Example: binary search” on page 87

RELATED CONCEPTS

“National groups” on page 133

RELATED TASKS

“Nesting tables” on page 69

“Referring to an item in a table” on page 70

“Putting values into a table” on page 73

“Creating variable-length tables (DEPENDING ON)” on page 78

“Using national groups” on page 134

“Doing a binary search (SEARCH ALL)” on page 87

“Defining numeric data” on page 43

RELATED REFERENCES

OCCURS clause (*Enterprise COBOL Language Reference*)

SIGN clause (*Enterprise COBOL Language Reference*)

ASCENDING KEY and DESCENDING KEY phrases

Nesting tables

To create a two-dimensional table, define a one-dimensional table in each occurrence of another one-dimensional table.

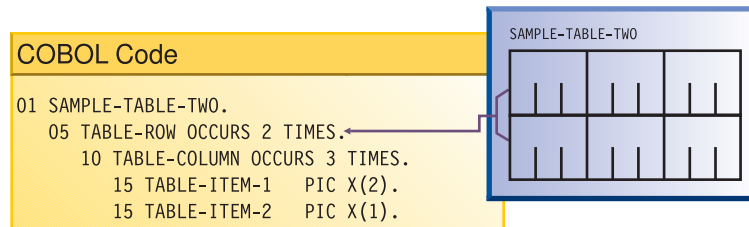

For example, in SAMPLE-TABLE-TWO above, TABLE-ROW is an element of a one-dimensional table that occurs two times. TABLE-COLUMN is an element of a two-dimensional table that occurs three times in each occurrence of TABLE-ROW.

To create a three-dimensional table, define a one-dimensional table in each occurrence of another one-dimensional table, which is itself contained in each occurrence of another one-dimensional table. For example:

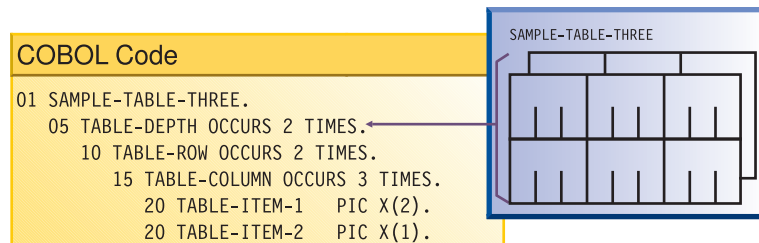

In SAMPLE-TABLE-THREE, TABLE-DEPTH is an element of a one-dimensional table that occurs two times. TABLE-ROW is an element of a two-dimensional table that occurs two times within each occurrence of TABLE-DEPTH. TABLE-COLUMN is an element of a three-dimensional table that occurs three times within each occurrence of TABLE-ROW.

In a two-dimensional table, the two subscripts correspond to the row and column numbers. In a three-dimensional table, the three subscripts correspond to the depth, row, and column numbers.

"Example: subscripting" on page 70

"Example: indexing" on page 70

RELATED TASKS

"Defining a table (OCCURS)" on page 67

"Referring to an item in a table" on page 70

"Putting values into a table" on page 73

"Creating variable-length tables (DEPENDING ON)" on page 78

"Searching a table" on page 85

"Processing table items using intrinsic functions" on page 89

"Handling tables efficiently" on page 664

RELATED REFERENCES

OCCURS clause (*Enterprise COBOL Language Reference*)

Example: subscripting

The following example shows valid references to SAMPLE-TABLE-THREE that use literal subscripts. The spaces are required in the second example.

```
TABLE-COLUMN (2, 2, 1)
TABLE-COLUMN (2 2 1)
```

In either table reference, the first value (2) refers to the second occurrence within TABLE-DEPTH, the second value (2) refers to the second occurrence within TABLE-ROW, and the third value (1) refers to the first occurrence within TABLE-COLUMN.

The following reference to SAMPLE-TABLE-TWO uses variable subscripts. The reference is valid if SUB1 and SUB2 are data-names that contain positive integer values within the range of the table.

```
TABLE-COLUMN (SUB1 SUB2)
```

RELATED TASKS

“Subscripting” on page 71

Example: indexing

The following example shows how displacements to elements that are referenced with indexes are calculated.

Consider the following three-dimensional table, SAMPLE-TABLE-FOUR:

```
01 SAMPLE-TABLE-FOUR
   05 TABLE-DEPTH OCCURS 3 TIMES INDEXED BY INX-A.
      10 TABLE-ROW OCCURS 4 TIMES INDEXED BY INX-B.
         15 TABLE-COLUMN OCCURS 8 TIMES INDEXED BY INX-C PIC X(8).
```

Suppose you code the following relative indexing reference to SAMPLE-TABLE-FOUR:

```
TABLE-COLUMN (INX-A + 1, INX-B + 2, INX-C - 1)
```

This reference causes the following computation of the displacement to the TABLE-COLUMN element:

```
(contents of INX-A) + (256 * 1)
+ (contents of INX-B) + (64 * 2)
+ (contents of INX-C) - (8 * 1)
```

This calculation is based on the following element lengths:

- Each occurrence of TABLE-DEPTH is 256 bytes in length (4 * 8 * 8).
- Each occurrence of TABLE-ROW is 64 bytes in length (8 * 8).
- Each occurrence of TABLE-COLUMN is 8 bytes in length.

RELATED TASKS

“Indexing” on page 72

Referring to an item in a table

A table element has a collective name, but the individual items within it do not have unique data-names.

To refer to an item, you have a choice of three techniques:

- Use the data-name of the table element, along with its occurrence number (called a *subscript*) in parentheses. This technique is called *subscripting*.
- Use the data-name of the table element, along with a value (called an *index*) that is added to the address of the table to locate an item (as a displacement from the beginning of the table). This technique is called *indexing*, or subscripting using index-names.
- Use both subscripts and indexes together.

RELATED TASKS

“Subscripting”

“Indexing” on page 72

Subscripting

The lowest possible subscript value is 1, which references the first occurrence of a table element. In a one-dimensional table, the subscript corresponds to the row number.

You can use a literal or a data-name as a subscript. If a data item that has a literal subscript is of fixed length, the compiler resolves the location of the data item.

When you use a data-name as a variable subscript, you must describe the data-name as an elementary numeric integer. The most efficient format is COMPUTATIONAL (COMP) with a PICTURE size that is smaller than five digits. You cannot use a subscript with a data-name that is used as a subscript. The code generated for the application resolves the location of a variable subscript at run time.

You can increment or decrement a literal or variable subscript by a specified integer amount. For example:

```
TABLE-COLUMN (SUB1 - 1, SUB2 + 3)
```

You can change part of a table element rather than the whole element. To do so, refer to the character position and length of the substring to be changed. For example:

```
01 ANY-TABLE.
   05 TABLE-ELEMENT    PIC X(10)
      OCCURS 3 TIMES    VALUE "ABCDEFGHIJ".
. . .
MOVE "??" TO TABLE-ELEMENT (1) (3 : 2).
```

The MOVE statement in the example above moves the string '??' into table element number 1, beginning at character position 3, for a length of 2 characters.

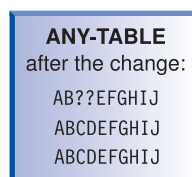
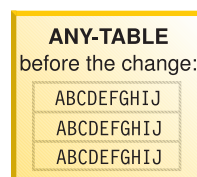

“Example: subscripting” on page 70

RELATED TASKS

“Indexing” on page 72

“Putting values into a table” on page 73
“Searching a table” on page 85
“Handling tables efficiently” on page 664

Indexing

You create an index by using the INDEXED BY phrase of the OCCURS clause to identify an index-name.

For example, INX-A in the following code is an index-name:

```
05 TABLE-ITEM PIC X(8)
   OCCURS 10 INDEXED BY INX-A.
```

The compiler calculates the value contained in the index as the occurrence number (subscript) minus 1, multiplied by the length of the table element. Therefore, for the fifth occurrence of TABLE-ITEM, the binary value contained in INX-A is $(5 - 1) * 8$, or 32.

You can use an index-name to reference another table only if both table descriptions have the same number of table elements, and the table elements are of the same length.

You can use the USAGE IS INDEX clause to create an index data item, and can use an index data item with any table. For example, INX-B in the following code is an index data item:

```
77 INX-B  USAGE IS INDEX.
. . .
  SET INX-A TO 10
  SET INX-B TO INX-A.
  PERFORM VARYING INX-A FROM 1 BY 1 UNTIL INX-A > INX-B
    DISPLAY TABLE-ITEM (INX-A)
. . .
  END-PERFORM.
```

The index-name INX-A is used to traverse table TABLE-ITEM above. The index data item INX-B is used to hold the index of the last element of the table. The advantage of this type of coding is that calculation of offsets of table elements is minimized, and no conversion is necessary for the UNTIL condition.

You can use the SET statement to assign to an index data item the value that you stored in an index-name, as in the statement SET INX-B TO INX-A above. For example, when you load records into a variable-length table, you can store the index value of the last record into a data item defined as USAGE IS INDEX. Then you can test for the end of the table by comparing the current index value with the index value of the last record. This technique is useful when you look through or process a table.

You can increment or decrement an index-name by an elementary integer data item or a nonzero integer literal, for example:

```
SET INX-A DOWN BY 3
```

The integer represents a number of occurrences. It is converted to an index value before being added to or subtracted from the index.

Initialize the index-name by using a SET, PERFORM VARYING, or SEARCH ALL statement. You can then use the index-name in SEARCH or relational condition statements. To change the value, use a PERFORM, SEARCH, or SET statement.

Because you are comparing a physical displacement, you can directly use index data items only in SEARCH and SET statements or in comparisons with indexes or other index data items. You cannot use index data items as subscripts or indexes.

“Example: indexing” on page 70

RELATED TASKS

“Subscripting” on page 71

“Putting values into a table”

“Searching a table” on page 85

“Processing table items using intrinsic functions” on page 89

“Handling tables efficiently” on page 664

RELATED REFERENCES

INDEXED BY phrase (*Enterprise COBOL Language Reference*)

INDEX phrase (*Enterprise COBOL Language Reference*)

SET statement (*Enterprise COBOL Language Reference*)

Putting values into a table

You can put values into a table by loading the table dynamically, initializing the table with the INITIALIZE statement, or assigning values with the VALUE clause when you define the table.

RELATED TASKS

“Loading a table dynamically”

“Loading a variable-length table” on page 80

“Initializing a table (INITIALIZE)”

“Assigning values when you define a table (VALUE)” on page 75

“Assigning values to a variable-length table” on page 81

Loading a table dynamically

If the initial values of a table are different with each execution of your program, you can define the table without initial values. You can instead read the changed values into the table dynamically before the program refers to the table.

To load a table, use the PERFORM statement and either subscripting or indexing.

When reading data to load your table, test to make sure that the data does not exceed the space allocated for the table. Use a named value (rather than a literal) for the maximum item count. Then, if you make the table bigger, you need to change only one value instead of all references to a literal.

“Example: PERFORM and subscripting” on page 76

“Example: PERFORM and indexing” on page 77

RELATED REFERENCES

PERFORM statement (*Enterprise COBOL Language Reference*)

Initializing a table (INITIALIZE)

You can load a table by coding one or more INITIALIZE statements.

For example, to move the value 3 into each of the elementary numeric data items in a table called TABLE-ONE, shown below, you can code the following statement:

```
INITIALIZE TABLE-ONE REPLACING NUMERIC DATA BY 3.
```

To move the character 'X' into each of the elementary alphanumeric data items in TABLE-ONE, you can code the following statement:

```
INITIALIZE TABLE-ONE REPLACING ALPHANUMERIC DATA BY "X".
```

When you use the INITIALIZE statement to initialize a table, the table is processed as a group item (that is, with group semantics); elementary data items within the group are recognized and processed. For example, suppose that TABLE-ONE is an alphanumeric group that is defined like this:

```
01 TABLE-ONE.
  02 Trans-out Occurs 20.
    05 Trans-code Pic X Value "R".
    05 Part-number Pic XX Value "13".
    05 Trans-quant Pic 99 Value 10.
    05 Price-fields.
      10 Unit-price Pic 99V Value 50.
      10 Discount Pic 99V Value 25.
      10 Sales-Price Pic 999 Value 375.
  .
  .
  .
  Initialize TABLE-ONE Replacing Numeric Data By 3
                          Alphanumeric Data By "X"
```

The table below shows the content that each of the twenty 12-byte elements Trans-out(*n*) has before execution and after execution of the INITIALIZE statement shown above:

Trans-out(<i>n</i>) before	Trans-out(<i>n</i>) after
R13105025375	XXb030303003 ¹
1. The symbol <i>b</i> represents a blank space.	

You can similarly use an INITIALIZE statement to load a table that is defined as a national group. For example, if TABLE-ONE shown above specified the GROUP-USAGE NATIONAL clause, and Trans-code and Part-number had N instead of X in their PICTURE clauses, the following statement would have the same effect as the INITIALIZE statement above, except that the data in TABLE-ONE would instead be encoded in UTF-16:

```
Initialize TABLE-ONE Replacing Numeric Data By 3
                          National Data By N"X"
```

The REPLACING NUMERIC phrase initializes floating-point data items also.

You can use the REPLACING phrase of the INITIALIZE statement similarly to initialize all of the elementary ALPHABETIC, DBCS, ALPHANUMERIC-EDITED, NATIONAL-EDITED, and NUMERIC-EDITED data items in a table.

The INITIALIZE statement cannot assign values to a variable-length table (that is, a table that was defined using the OCCURS DEPENDING ON clause).

“Examples: initializing data items” on page 28

RELATED TASKS

“Initializing a structure (INITIALIZE)” on page 30

“Assigning values when you define a table (VALUE)” on page 75

“Assigning values to a variable-length table” on page 81

“Looping through a table” on page 103

“Using data items and group items” on page 24

“Using national groups” on page 134

RELATED REFERENCES

INITIALIZE statement (*Enterprise COBOL Language Reference*)

Assigning values when you define a table (VALUE)

If a table is to contain stable values (such as days and months), you can set the specific values when you define the table.

Set static values in tables in one of these ways:

- Initialize each table item individually.
- Initialize an entire table at the group level.
- Initialize all occurrences of a given table element to the same value.

RELATED TASKS

“Initializing each table item individually”

“Initializing a table at the group level” on page 76

“Initializing all occurrences of a given table element” on page 76

“Initializing a structure (INITIALIZE)” on page 30

Initializing each table item individually

If a table is small, you can set the value of each item individually by using a VALUE clause.

Use the following technique, which is shown in the example code below:

1. Define a record (such as Error-Flag-Table below) that contains the items that are to be in the table.
2. Set the initial value of each item in a VALUE clause.
3. Code a REDEFINES entry to make the record into a table.

```

*****
***          E R R O R   F L A G   T A B L E          ***
*****
01 Error-Flag-Table                                Value Spaces.
   88 No-Errors                                    Value Spaces.
   05 Type-Error                                   Pic X.
   05 Shift-Error                                  Pic X.
   05 Home-Code-Error                              Pic X.
   05 Work-Code-Error                              Pic X.
   05 Name-Error                                    Pic X.
   05 Initials-Error                               Pic X.
   05 Duplicate-Error                              Pic X.
   05 Not-Found-Error                              Pic X.
01 Filler Redefines Error-Flag-Table.
   05 Error-Flag Occurs 8 Times
       Indexed By Flag-Index                        Pic X.

```

In the example above, the VALUE clause at the 01 level initializes each of the table items to the same value. Each table item could instead be described with its own VALUE clause to initialize that item to a distinct value.

To initialize larger tables, use MOVE, PERFORM, or INITIALIZE statements.

RELATED TASKS

“Initializing a structure (INITIALIZE)” on page 30

“Assigning values to a variable-length table” on page 81

RELATED REFERENCES

REDEFINES clause (*Enterprise COBOL Language Reference*)

OCCURS clause (*Enterprise COBOL Language Reference*)

Initializing a table at the group level

Code an alphanumeric or national group data item and assign to it, through the VALUE clause, the contents of the whole table. Then, in a subordinate data item, use an OCCURS clause to define the individual table items.

In the following example, the alphanumeric group data item TABLE-ONE uses a VALUE clause that initializes each of the four elements of TABLE-TWO:

```
01 TABLE-ONE                VALUE "1234".
   05 TABLE-TWO OCCURS 4 TIMES PIC X.
```

In the following example, the national group data item Table-OneN uses a VALUE clause that initializes each of the three elements of the subordinate data item Table-TwoN (each of which is implicitly USAGE NATIONAL). Note that you can initialize a national group data item with a VALUE clause that uses an alphanumeric literal, as shown below, or a national literal.

```
01 Table-OneN Group-Usage National Value "AB12CD34EF56".
   05 Table-TwoN Occurs 3 Times Indexed By MyI.
       10 ElementOneN Pic nn.
       10 ElementTwoN Pic 99.
```

After Table-OneN is initialized, ElementOneN(1) contains NX"00410042" (the UTF-16 representation of 'AB'), the national decimal item ElementTwoN(1) contains NX"00310032" (the UTF-16 representation of '12'), and so forth.

RELATED REFERENCES

OCCURS clause (*Enterprise COBOL Language Reference*)

GROUP-USAGE clause (*Enterprise COBOL Language Reference*)

Initializing all occurrences of a given table element

You can use the VALUE clause in the data description of a table element to initialize all instances of that element to the specified value.

```
01 T2.
   05 T-OBJ                PIC 9   VALUE 3.
   05 T OCCURS 5 TIMES
       DEPENDING ON T-OBJ.
       10 X                PIC XX  VALUE "AA".
       10 Y                PIC 99  VALUE 19.
       10 Z                PIC XX  VALUE "BB".
```

For example, the code above causes all the X elements (1 through 5) to be initialized to AA, all the Y elements (1 through 5) to be initialized to 19, and all the Z elements (1 through 5) to be initialized to BB. T-OBJ is then set to 3.

RELATED TASKS

“Assigning values to a variable-length table” on page 81

RELATED REFERENCES

OCCURS clause (*Enterprise COBOL Language Reference*)

Example: PERFORM and subscripting

This example traverses an error-flag table using subscripting until an error code that has been set is found. If an error code is found, the corresponding error message is moved to a print report field.

```

*****
***      E R R O R   F L A G   T A B L E      ***
*****
01 Error-Flag-Table          Value Spaces.
  88 No-Errors              Value Spaces.
    05 Type-Error          Pic X.
    05 Shift-Error        Pic X.
    05 Home-Code-Error    Pic X.
    05 Work-Code-Error    Pic X.
    05 Name-Error         Pic X.
    05 Initials-Error     Pic X.
    05 Duplicate-Error    Pic X.
    05 Not-Found-Error    Pic X.
01 Filler Redefines Error-Flag-Table.
  05 Error-Flag Occurs 8 Times
    Indexed By Flag-Index  Pic X.
77 Error-on                  Pic X Value "E".
*****
***      E R R O R   M E S S A G E   T A B L E      ***
*****
01 Error-Message-Table.
  05 Filler                  Pic X(25) Value
    "Transaction Type Invalid".
  05 Filler                  Pic X(25) Value
    "Shift Code Invalid".
  05 Filler                  Pic X(25) Value
    "Home Location Code Inval.".
  05 Filler                  Pic X(25) Value
    "Work Location Code Inval.".
  05 Filler                  Pic X(25) Value
    "Last Name - Blanks".
  05 Filler                  Pic X(25) Value
    "Initials - Blanks".
  05 Filler                  Pic X(25) Value
    "Duplicate Record Found".
  05 Filler                  Pic X(25) Value
    "Commuter Record Not Found".
01 Filler Redefines Error-Message-Table.
  05 Error-Message Occurs 8 Times
    Indexed By Message-Index  Pic X(25).
. . .
PROCEDURE DIVISION.
. . .
Perform
  Varying Sub From 1 By 1
  Until No-Errors
  If Error-Flag (Sub) = Error-0n
  Move Space To Error-Flag (Sub)
  Move Error-Message (Sub) To Print-Message
  Perform 260-Print-Report
  End-If
End-Perform
. . .

```

Example: PERFORM and indexing

This example traverses an error-flag table using indexing until an error code that has been set is found. If an error code is found, the corresponding error message is moved to a print report field.

```

*****
***      E R R O R   F L A G   T A B L E      ***
*****
01 Error-Flag-Table          Value Spaces.
  88 No-Errors              Value Spaces.
    05 Type-Error          Pic X.
    05 Shift-Error        Pic X.

```

```

05 Home-Code-Error          Pic X.
05 Work-Code-Error         Pic X.
05 Name-Error              Pic X.
05 Initials-Error         Pic X.
05 Duplicate-Error        Pic X.
05 Not-Found-Error        Pic X.
01 Filler Redefines Error-Flag-Table.
05 Error-Flag Occurs 8 Times
    Indexed By Flag-Index      Pic X.
77 Error-on                 Pic X Value "E".
*****
***      E R R O R   M E S S A G E   T A B L E      ***
*****
01 Error-Message-Table.
05 Filler                   Pic X(25) Value
    "Transaction Type Invalid".
05 Filler                   Pic X(25) Value
    "Shift Code Invalid".
05 Filler                   Pic X(25) Value
    "Home Location Code Inval.".
05 Filler                   Pic X(25) Value
    "Work Location Code Inval.".
05 Filler                   Pic X(25) Value
    "Last Name - Blanks".
05 Filler                   Pic X(25) Value
    "Initials - Blanks".
05 Filler                   Pic X(25) Value
    "Duplicate Record Found".
05 Filler                   Pic X(25) Value
    "Commuter Record Not Found".
01 Filler Redefines Error-Message-Table.
05 Error-Message Occurs 8 Times
    Indexed By Message-Index  Pic X(25).

. . .
PROCEDURE DIVISION.
. . .
Set Flag-Index To 1
Perform Until No-Errors
    Search Error-Flag
        When Error-Flag (Flag-Index) = Error-On
            Move Space To Error-Flag (Flag-Index)
            Set Message-Index To Flag-Index
            Move Error-Message (Message-Index) To
                Print-Message
            Perform 260-Print-Report
        End-Search
    End-Perform
. . .

```

Creating variable-length tables (DEPENDING ON)

If you do not know before run time how many times a table element occurs, define a variable-length table. To do so, use the OCCURS DEPENDING ON (ODO) clause.

```
X OCCURS 1 TO 10 TIMES DEPENDING ON Y
```

In the example above, X is called the *ODO subject*, and Y is called the *ODO object*.

You can also specify unbounded tables and groups, see Variable-length tables in the *Enterprise COBOL Language Reference* for details.

Two factors affect the successful manipulation of variable-length records:

- Correct calculation of record lengths

The length of the variable portions of a group item is the product of the object of the DEPENDING ON phrase and the length of the subject of the OCCURS clause.

- Conformance of the data in the object of the OCCURS DEPENDING ON clause to its PICTURE clause

If the content of the ODO object does not match its PICTURE clause, the program could terminate abnormally. You must ensure that the ODO object correctly specifies the current number of occurrences of table elements.

The following example shows a group item (REC-1) that contains both the subject and object of the OCCURS DEPENDING ON clause. The way the length of the group item is determined depends on whether it is sending or receiving data.

```
WORKING-STORAGE SECTION.  
01 MAIN-AREA.  
    03 REC-1.  
        05 FIELD-1                               PIC 9.  
        05 FIELD-2 OCCURS 1 TO 5 TIMES  
            DEPENDING ON FIELD-1                 PIC X(05).  
01 REC-2.  
    03 REC-2-DATA                               PIC X(50).
```

If you want to move REC-1 (the sending item in this case) to REC-2, the length of REC-1 is determined immediately before the move, using the current value in FIELD-1. If the content of FIELD-1 conforms to its PICTURE clause (that is, if FIELD-1 contains a zoned decimal item), the move can proceed based on the actual length of REC-1. Otherwise, the result is unpredictable. You must ensure that the ODO object has the correct value before you initiate the move.

When you do a move to REC-1 (the receiving item in this case), the length of REC-1 is determined using the maximum number of occurrences. In this example, five occurrences of FIELD-2, plus FIELD-1, yields a length of 26 bytes. In this case, you do not need to set the ODO object (FIELD-1) before referencing REC-1 as a receiving item. However, the sending field's ODO object (not shown) must be set to a valid numeric value between 1 and 5 for the ODO object of the receiving field to be validly set by the move.

However, if you do a move to REC-1 (again the receiving item) where REC-1 is followed by a variably located group (a type of *complex ODO*), the actual length of REC-1 is calculated immediately before the move, using the current value of the ODO object (FIELD-1). In the following example, REC-1 and REC-2 are in the same record, but REC-2 is not subordinate to REC-1 and is therefore variably located:

```
01 MAIN-AREA  
    03 REC-1.  
        05 FIELD-1                               PIC 9.  
        05 FIELD-3                               PIC 9.  
        05 FIELD-2 OCCURS 1 TO 5 TIMES  
            DEPENDING ON FIELD-1                 PIC X(05).  
    03 REC-2.  
        05 FIELD-4 OCCURS 1 TO 5 TIMES  
            DEPENDING ON FIELD-3                 PIC X(05).
```

The compiler issues a message that lets you know that the actual length was used. This case requires that you set the value of the ODO object before using the group item as a receiving field.

The following example shows how to define a variable-length table when the ODO object (LOCATION-TABLE-LENGTH below) is outside the group:

```

DATA DIVISION.
FILE SECTION.
FD LOCATION-FILE
  RECORDING MODE F
  BLOCK 0 RECORDS
  RECORD 80 CHARACTERS
  LABEL RECORD STANDARD.
01 LOCATION-RECORD.
  05 LOC-CODE PIC XX.
  05 LOC-DESCRIPTION PIC X(20).
  05 FILLER PIC X(58).
WORKING-STORAGE SECTION.
01 FLAGS.
  05 LOCATION-EOF-FLAG PIC X(5) VALUE SPACE.
  88 LOCATION-EOF VALUE "FALSE".
01 MISC-VALUES.
  05 LOCATION-TABLE-LENGTH PIC 9(3) VALUE ZERO.
  05 LOCATION-TABLE-MAX PIC 9(3) VALUE 100.
*****
*** LOC A T I O N T A B L E ***
*** FILE CONTAINS LOCATION CODES. ***
*****
01 LOCATION-TABLE.
  05 LOCATION-CODE OCCURS 1 TO 100 TIMES
    DEPENDING ON LOCATION-TABLE-LENGTH PIC X(80).

```

RELATED CONCEPTS

“Complex OCCURS DEPENDING ON” on page 81

RELATED TASKS

“Assigning values to a variable-length table” on page 81

“Loading a variable-length table”

“Preventing overlay when adding elements to a variable table” on page 84

“Finding the length of data items” on page 122

RELATED REFERENCES

OCCURS DEPENDING ON clause (*Enterprise COBOL Language Reference*)

Variable-length tables (*Enterprise COBOL Language Reference*)

Loading a variable-length table

You can use a *do-until* structure (a TEST AFTER loop) to control the loading of a variable-length table. For example, after the following code runs, LOCATION-TABLE-LENGTH contains the subscript of the last item in the table.

```

DATA DIVISION.
FILE SECTION.
FD LOCATION-FILE
  RECORDING MODE F
  BLOCK 0 RECORDS
  RECORD 80 CHARACTERS
  LABEL RECORD STANDARD.
01 LOCATION-RECORD.
  05 LOC-CODE PIC XX.
  05 LOC-DESCRIPTION PIC X(20).
  05 FILLER PIC X(58).
. . .
WORKING-STORAGE SECTION.
01 FLAGS.
  05 LOCATION-EOF-FLAG PIC X(5) VALUE SPACE.
  88 LOCATION-EOF VALUE "YES".
01 MISC-VALUES.
  05 LOCATION-TABLE-LENGTH PIC 9(3) VALUE ZERO.
  05 LOCATION-TABLE-MAX PIC 9(3) VALUE 100.
*****

```



```

***          L O C A T I O N   T A B L E          ***
***          FILE CONTAINS LOCATION CODES.      ***
*****
01 LOCATION-TABLE.
   05 LOCATION-CODE OCCURS 1 TO 100 TIMES
      DEPENDING ON LOCATION-TABLE-LENGTH  PIC X(80).
. . .
PROCEDURE DIVISION.
. . .
  Perform Test After
    Varying Location-Table-Length From 1 By 1
      Until Location-EOF
        Or Location-Table-Length = Location-Table-Max
    Move Location-Record To
      Location-Code (Location-Table-Length)
    Read Location-File
      At End Set Location-EOF To True
    End-Read
  End-Perform

```

Assigning values to a variable-length table

You can code a VALUE clause for an alphanumeric or national group item that has a subordinate data item that contains the OCCURS clause with the DEPENDING ON phrase. Each subordinate structure that contains the DEPENDING ON phrase is initialized using the maximum number of occurrences.

If you define the entire table by using the DEPENDING ON phrase, all the elements are initialized using the maximum defined value of the ODO (OCCURS DEPENDING ON) object.

If the ODO object is initialized by a VALUE clause, it is logically initialized after the ODO subject has been initialized.

```

01 TABLE-THREE          VALUE "3ABCDE".
   05 X                   PIC 9.
   05 Y OCCURS 5 TIMES
      DEPENDING ON X  PIC X.

```

For example, in the code above, the ODO subject Y(1) is initialized to 'A', Y(2) to 'B', . . ., Y(5) to 'E', and finally the ODO object X is initialized to 3. Any subsequent reference to TABLE-THREE (such as in a DISPLAY statement) refers to X and the first three elements, Y(1) through Y(3), of the table.

RELATED TASKS

“Assigning values when you define a table (VALUE)” on page 75

RELATED REFERENCES

OCCURS DEPENDING ON clause (*Enterprise COBOL Language Reference*)

Complex OCCURS DEPENDING ON

Several types of complex OCCURS DEPENDING ON (*complex ODO*) are possible. Complex ODO is supported as an extension to the 85 COBOL Standard.

The basic forms of complex ODO permitted by the compiler are as follows:

- Variably located item or group: A data item described by an OCCURS clause with the DEPENDING ON phrase is followed by a nonsubordinate elementary or group data item.

- Variably located table: A data item described by an OCCURS clause with the DEPENDING ON phrase is followed by a nonsubordinate data item described by an OCCURS clause.
- Table that has variable-length elements: A data item described by an OCCURS clause contains a subordinate data item described by an OCCURS clause with the DEPENDING ON phrase.
- Index name for a table that has variable-length elements.
- Element of a table that has variable-length elements.

“Example: complex ODO”

RELATED TASKS

“Preventing index errors when changing ODO object value” on page 83

“Preventing overlay when adding elements to a variable table” on page 84

RELATED REFERENCES

“Effects of change in ODO object value” on page 83

OCCURS DEPENDING ON clause (*Enterprise COBOL Language Reference*)

Example: complex ODO

The following example illustrates the possible types of occurrence of complex ODO.

```

01 FIELD-A.
  02 COUNTER-1                PIC S99.
  02 COUNTER-2                PIC S99.
  02 TABLE-1.
    03 RECORD-1 OCCURS 1 TO 5 TIMES
      DEPENDING ON COUNTER-1  PIC X(3).
  02 EMPLOYEE-NUMBER          PIC X(5). (1)
  02 TABLE-2 OCCURS 5 TIMES  (2) (3)
    INDEXED BY INDX.         (4)
  03 TABLE-ITEM              PIC 99.   (5)
  03 RECORD-2 OCCURS 1 TO 3 TIMES
    DEPENDING ON COUNTER-2.
  04 DATA-NUM                PIC S99.

```

Definition: In the example, COUNTER-1 is an *ODO object*, that is, it is the object of the DEPENDING ON clause of RECORD-1. RECORD-1 is said to be an *ODO subject*. Similarly, COUNTER-2 is the ODO object of the corresponding ODO subject, RECORD-2.

The types of complex ODO occurrences shown in the example above are as follows:

- (1) A variably located item: EMPLOYEE-NUMBER is a data item that follows, but is not subordinate to, a variable-length table in the same level-01 record.
- (2) A variably located table: TABLE-2 is a table that follows, but is not subordinate to, a variable-length table in the same level-01 record.
- (3) A table with variable-length elements: TABLE-2 is a table that contains a subordinate data item, RECORD-2, whose number of occurrences varies depending on the content of its ODO object.
- (4) An index-name, INDX, for a table that has variable-length elements.
- (5) An element, TABLE-ITEM, of a table that has variable-length elements.

How length is calculated

The length of the variable portion of each record is the product of its ODO object and the length of its ODO subject. For example, whenever a reference is made to one of the complex ODO items shown above, the actual length, if used, is computed as follows:

- The length of TABLE-1 is calculated by multiplying the contents of COUNTER-1 (the number of occurrences of RECORD-1) by 3 (the length of RECORD-1).
- The length of TABLE-2 is calculated by multiplying the contents of COUNTER-2 (the number of occurrences of RECORD-2) by 2 (the length of RECORD-2), and adding the length of TABLE-ITEM.
- The length of FIELD-A is calculated by adding the lengths of COUNTER-1, COUNTER-2, TABLE-1, EMPLOYEE-NUMBER, and TABLE-2 times 5.

Setting values of ODO objects

You must set *every* ODO object in a group item before you reference any complex ODO item in the group. For example, before you refer to EMPLOYEE-NUMBER in the code above, you must set COUNTER-1 and COUNTER-2 even though EMPLOYEE-NUMBER does not directly depend on either ODO object for its value.

Restriction: An ODO object cannot be variably located.

Effects of change in ODO object value

If a data item that is described by an OCCURS clause with the DEPENDING ON phrase is followed in the same group by one or more nonsubordinate data items (a form of complex ODO), any change in value of the ODO object affects subsequent references to complex ODO items in the record.

For example:

- The size of any group that contains the relevant ODO clause reflects the new value of the ODO object.
- A MOVE to a group that contains the ODO subject is made based on the new value of the ODO object.
- The location of any nonsubordinate items that follow the item described with the ODO clause is affected by the new value of the ODO object. (To preserve the contents of the nonsubordinate items, move them to a work area before the value of the ODO object changes, then move them back.)

The value of an ODO object can change when you move data to the ODO object or to the group in which it is contained. The value can also change if the ODO object is contained in a record that is the target of a READ statement.

RELATED TASKS

“Preventing index errors when changing ODO object value”

“Preventing overlay when adding elements to a variable table” on page 84

Preventing index errors when changing ODO object value

Be careful if you reference a complex-ODO index-name, that is, an index-name for a table that has variable-length elements, after having changed the value of the ODO object for a subordinate data item in the table.

When you change the value of an ODO object, the byte offset in an associated complex-ODO index is no longer valid because the table length has changed. Unless you take precautions, you will have unexpected results if you then code a reference to the index-name such as:

- A reference to an element of the table
- A SET statement of the form SET *integer-data-item* TO *index-name* (format 1)
- A SET statement of the form SET *index-name* UP|DOWN BY *integer* (format 2)

To avoid this type of error, do these steps:

1. Save the index in an integer data item. (Doing so causes an implicit conversion: the integer item receives the table element occurrence number that corresponds to the offset in the index.)
2. Change the value of the ODO object.
3. Immediately restore the index from the integer data item. (Doing so causes an implicit conversion: the index-name receives the offset that corresponds to the table element occurrence number in the integer item. The offset is computed according to the table length then in effect.)

The following code shows how to save and restore the index-name (shown in “Example: complex ODO” on page 82) when the ODO object COUNTER-2 changes.

```

77 INTEGER-DATA-ITEM-1      PIC 99.
. . .
  SET INDX TO 5.
*   INDX is valid at this point.
  SET INTEGER-DATA-ITEM-1 TO INDX.
*   INTEGER-DATA-ITEM-1 now has the
*   occurrence number that corresponds to INDX.
  MOVE NEW-VALUE TO COUNTER-2.
*   INDX is not valid at this point.
  SET INDX TO INTEGER-DATA-ITEM-1.
*   INDX is now valid, containing the offset
*   that corresponds to INTEGER-DATA-ITEM-1, and
*   can be used with the expected results.

```

RELATED REFERENCES

SET statement (*Enterprise COBOL Language Reference*)

Preventing overlay when adding elements to a variable table

Be careful if you increase the number of elements in a variable-occurrence table that is followed by one or more nonsubordinate data items in the same group. When you increment the value of the ODO object and add an element to a table, you can inadvertently overlay the variably located data items that follow the table.

To avoid this type of error, do these steps:

1. Save the variably located data items that follow the table in another data area.
2. Increment the value of the ODO object.
3. Move data into the new table element (if needed).
4. Restore the variably located data items from the data area where you saved them.

In the following example, suppose you want to add an element to the table VARY-FIELD-1, whose number of elements depends on the ODO object CONTROL-1. VARY-FIELD-1 is followed by the nonsubordinate variably located data item GROUP-ITEM-1, whose elements could potentially be overlaid.

```

WORKING-STORAGE SECTION.
01 VARIABLE-REC.
   05 FIELD-1                PIC X(10).
   05 CONTROL-1              PIC S99.
   05 CONTROL-2              PIC S99.
   05 VARY-FIELD-1 OCCURS 1 TO 10 TIMES

```

```

        DEPENDING ON CONTROL-1          PIC X(5).
05  GROUP-ITEM-1.
    10  VARY-FIELD-2
        OCCURS 1 TO 10 TIMES
        DEPENDING ON CONTROL-2          PIC X(9).
01  STORE-VARY-FIELD-2.
    05  GROUP-ITEM-2.
    10  VARY-FLD-2
        OCCURS 1 TO 10 TIMES
        DEPENDING ON CONTROL-2          PIC X(9).

```

Each element of VARY-FIELD-1 has 5 bytes, and each element of VARY-FIELD-2 has 9 bytes. If CONTROL-1 and CONTROL-2 both contain the value 3, you can picture storage for VARY-FIELD-1 and VARY-FIELD-2 as follows:

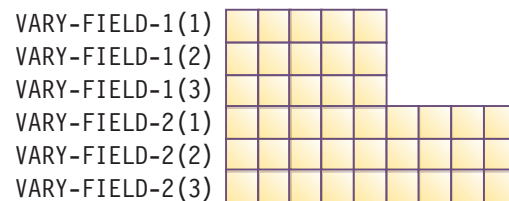

To add a fourth element to VARY-FIELD-1, code as follows to prevent overlaying the first 5 bytes of VARY-FIELD-2. (GROUP-ITEM-2 serves as temporary storage for the variably located GROUP-ITEM-1.)

```

MOVE GROUP-ITEM-1 TO GROUP-ITEM-2.
ADD 1 TO CONTROL-1.
MOVE five-byte-field TO
    VARY-FIELD-1 (CONTROL-1).
MOVE GROUP-ITEM-2 TO GROUP-ITEM-1.

```

You can picture the updated storage for VARY-FIELD-1 and VARY-FIELD-2 as follows:

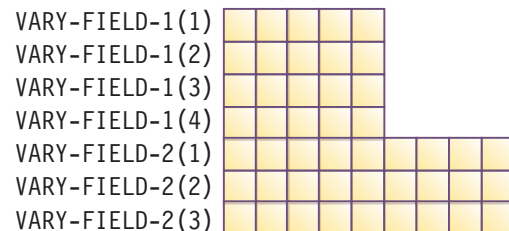

Note that the fourth element of VARY-FIELD-1 did not overlay the first element of VARY-FIELD-2.

Searching a table

COBOL provides two search techniques for tables: *serial* and *binary*.

To do serial searches, use SEARCH and indexing. For variable-length tables, you can use PERFORM with subscripting or indexing.

To do binary searches, use SEARCH ALL and indexing.

A binary search can be considerably more efficient than a serial search. For a serial search, the number of comparisons is of the order of n , the number of entries in

the table. For a binary search, the number of comparisons is of the order of only the logarithm (base 2) of n . A binary search, however, requires that the table items already be sorted.

RELATED TASKS

“Doing a serial search (SEARCH)”

“Doing a binary search (SEARCH ALL)” on page 87

Doing a serial search (SEARCH)

Use the SEARCH statement to do a serial (sequential) search beginning at the current index setting. To modify the index setting, use the SET statement.

The conditions in the WHEN phrase are evaluated in the order in which they appear:

- If none of the conditions is satisfied, the index is increased to correspond to the next table element, and the WHEN conditions are evaluated again.
- If one of the WHEN conditions is satisfied, the search ends. The index remains pointing to the table element that satisfied the condition.
- If the entire table has been searched and no conditions were met, the AT END imperative statement is executed if there is one. If you did not code AT END, control passes to the next statement in the program.

You can reference only one level of a table (a table element) with each SEARCH statement. To search multiple levels of a table, use nested SEARCH statements. Delimit each nested SEARCH statement with END-SEARCH.

Performance: If the found condition comes after some intermediate point in the table, you can speed up the search by using the SET statement to set the index to begin the search after that point. Arranging the table so that the data used most often is at the beginning of the table also enables more efficient serial searching. If the table is large and is presorted, a binary search is more efficient.

“Example: serial search”

RELATED REFERENCES

SEARCH statement (*Enterprise COBOL Language Reference*)

Example: serial search

The following example shows how you might find a particular string in the innermost table of a three-dimensional table.

Each dimension of the table has its own index (set to 1, 4, and 1, respectively). The innermost table (TABLE-ENTRY3) has an ascending key.

```
01 TABLE-ONE.  
   05 TABLE-ENTRY1 OCCURS 10 TIMES  
      INDEXED BY TE1-INDEX.  
   10 TABLE-ENTRY2 OCCURS 10 TIMES  
      INDEXED BY TE2-INDEX.  
   15 TABLE-ENTRY3 OCCURS 5 TIMES  
      ASCENDING KEY IS KEY1  
      INDEXED BY TE3-INDEX.  
      20 KEY1 PIC X(5).  
      20 KEY2 PIC X(10).  
.  
.  
PROCEDURE DIVISION.  
.  
.  
   SET TE1-INDEX TO 1  
   SET TE2-INDEX TO 4
```

```

SET TE3-INDEX TO 1
MOVE "A1234" TO KEY1 (TE1-INDEX, TE2-INDEX, TE3-INDEX + 2)
MOVE "AAAAAAA00" TO KEY2 (TE1-INDEX, TE2-INDEX, TE3-INDEX + 2)
. . .
SEARCH TABLE-ENTRY3
  AT END
    MOVE 4 TO RETURN-CODE
  WHEN TABLE-ENTRY3(TE1-INDEX, TE2-INDEX, TE3-INDEX)
    = "A1234AAAAAAA00"
    MOVE 0 TO RETURN-CODE
END-SEARCH

```

Values after execution:

```

TE1-INDEX = 1
TE2-INDEX = 4
TE3-INDEX points to the TABLE-ENTRY3 item
               that equals "A1234AAAAAAA00"
RETURN-CODE = 0

```

Doing a binary search (SEARCH ALL)

If you use SEARCH ALL to do a binary search, you do not need to set the index before you begin. The index is always the one that is associated with the first index-name in the OCCURS clause. The index varies during execution to maximize the search efficiency.

To use the SEARCH ALL statement to search a table, the table must specify the ASCENDING or DESCENDING KEY phrases of the OCCURS clause, or both, and must already be ordered on the key or keys that are specified in the ASCENDING and DESCENDING KEY phrases. You can use a format 2 SORT statement to order the table according to its defined keys, thereby making the table searchable by the SEARCH ALL statement. Note that SEARCH ALL will return unpredictable results if the table has not been ordered according to the keys.

In the WHEN phrase of the SEARCH ALL statement, you can test any key that is named in the ASCENDING or DESCENDING KEY phrases for the table, but you must test all preceding keys, if any. The test must be an equal-to condition, and the WHEN phrase must specify either a key (subscripted by the first index-name associated with the table) or a condition-name that is associated with the key. The WHEN condition can be a compound condition that is formed from simple conditions that use AND as the only logical connective.

Each key and its object of comparison must be compatible according to the rules for comparison of data items. Note though that if a key is compared to a national literal or identifier, the key must be a national data item.

“Example: binary search”

RELATED TASKS

“Defining a table (OCCURS)” on page 67

RELATED REFERENCES

SEARCH statement (*Enterprise COBOL Language Reference*)

General relation conditions (*Enterprise COBOL Language Reference*)

Example: binary search

The following example shows how you can code a binary search of a table.

Suppose you define a table that contains 90 elements of 40 bytes each, and three keys. The primary and secondary keys (KEY-1 and KEY-2) are in ascending order, but the least significant key (KEY-3) is in descending order:

```
01 TABLE-A.  
  05 TABLE-ENTRY OCCURS 90 TIMES  
    ASCENDING KEY-1, KEY-2  
    DESCENDING KEY-3  
    INDEXED BY INDX-1.  
  10 PART-1      PIC 99.  
  10 KEY-1       PIC 9(5).  
  10 PART-2     PIC 9(6).  
  10 KEY-2       PIC 9(4).  
  10 PART-3     PIC 9(18).  
  10 KEY-3      PIC 9(5).
```

You can search this table by using the following statements:

```
SEARCH ALL TABLE-ENTRY  
  AT END  
  PERFORM NOENTRY  
  WHEN KEY-1 (INDX-1) = VALUE-1 AND  
    KEY-2 (INDX-1) = VALUE-2 AND  
    KEY-3 (INDX-1) = VALUE-3  
  MOVE PART-1 (INDX-1) TO OUTPUT-AREA  
END-SEARCH
```

If an entry is found in which each of the three keys is equal to the value to which it is compared (VALUE-1, VALUE-2, and VALUE-3, respectively), PART-1 of that entry is moved to OUTPUT-AREA. If no matching key is found in the entries in TABLE-A, the NOENTRY routine is performed.

Sorting a table

You can sort a table by using the format 2 SORT statement. It is part of the 2002 COBOL Standard.

The format 2 SORT statement sorts table elements according to the specified table keys, and it is especially useful for tables used with SEARCH ALL. You can specify the keys for sorting as part of the table definition, which can also be used in the SEARCH ALL statement. Alternatively, you can also specify the keys for sorting as part of the SORT statement, either if you want to sort the table using different keys than those specified in the table definition, or if the table has no keys specified.

With the format 2 SORT statement, you don't need to use the input and output procedures as you do with the format 1 SORT statement.

See the following example in which the table is sorted based on specified keys:

```
WORKING-STORAGE SECTION.  
01 GROUP-ITEM.  
  05 TABL OCCURS 10 TIMES  
    10 ELEM-ITEM1 PIC X.  
    10 ELEM-ITEM2 PIC X.  
    10 ELEM-ITEM3 PIC X.  
  ...  
PROCEDURE DIVISION.  
  ...  
  SORT TABL DESCENDING ELEM-ITEM2 ELEM-ITEM3.  
  IF TABL (1)...
```

RELATED REFERENCES

Sort statement (Enterprise COBOL Language Reference)
"Using the format 2 SORT statement to sort a table" on page 681

Processing table items using intrinsic functions

You can use intrinsic functions to process alphabetic, alphanumeric, national, or numeric table items. (You can process DBCS data items only with the NATIONAL-OF intrinsic function.) The data descriptions of the table items must be compatible with the requirements for the function arguments.

Use a subscript or index to reference an individual data item as a function argument. For example, assuming that Table-One is a 3 x 3 array of numeric items, you can find the square root of the middle element by using this statement:

```
Compute X = Function Sqrt(Table-One(2,2))
```

You might often need to iteratively process the data in tables. For intrinsic functions that accept multiple arguments, you can use the subscript ALL to reference all the items in the table or in a single dimension of the table. The iteration is handled automatically, which can make your code shorter and simpler.

You can mix scalars and array arguments for functions that accept multiple arguments:

```
Compute Table-Median = Function Median(Arg1 Table-One(ALL))
```

"Example: processing tables using intrinsic functions"

RELATED TASKS

"Using intrinsic functions (built-in functions)" on page 38
"Converting data items (intrinsic functions)" on page 116
"Evaluating data items (intrinsic functions)" on page 119

RELATED REFERENCES

Intrinsic functions (Enterprise COBOL Language Reference)

Example: processing tables using intrinsic functions

These examples show how you can apply an intrinsic function to some or all of the elements in a table by using the ALL subscript.

Assuming that Table-Two is a 2 x 3 x 2 array, the following statement adds the values in elements Table-Two(1,3,1), Table-Two(1,3,2), Table-Two(2,3,1), and Table-Two(2,3,2):

```
Compute Table-Sum = FUNCTION SUM (Table-Two(ALL, 3, ALL))
```

The following example computes various salary values for all the employees whose salaries are encoded in Employee-Table:

```
01 Employee-Table.  
   05 Emp-Count      Pic s9(4) usage binary.  
   05 Emp-Record     Occurs 1 to 500 times  
                       depending on Emp-Count.  
       10 Emp-Name    Pic x(20).  
       10 Emp-Idme    Pic 9(9).  
       10 Emp-Salary  Pic 9(7)v99.  
   . . .  
Procedure Division.  
   Compute Max-Salary = Function Max(Emp-Salary(ALL))
```

```

Compute I           = Function Ord-Max(Emp-Salary(ALL))
Compute Avg-Salary  = Function Mean(Emp-Salary(ALL))
Compute Salary-Range = Function Range(Emp-Salary(ALL))
Compute Total-Payroll = Function Sum(Emp-Salary(ALL))

```

Working with unbounded tables and groups

You can process an unbounded group as the input parameter to a called program. The memory for the unbounded group is provided by the calling program. Alternatively, you can define, initialize, and process unbounded groups in a single program.

To work with unbounded tables and groups in a single program, do these steps:

1. In the LINKAGE SECTION, define an unbounded table (with the syntax of OCCURS *n* TO UNBOUNDED), which will be part of an unbounded group.
2. In the WORKING-STORAGE SECTION or LOCAL-STORAGE SECTION, define the OCCURS DEPENDING ON objects.
3. In the PROCEDURE DIVISION, do these steps to process unbounded groups:
 - a. Set the OCCURS DEPENDING ON objects.
 - b. Use the LENGTH special register or the LENGTH intrinsic function to compute the total size of the group.
 - c. Use the CALL statement to call a storage allocation service, such as the Language Environment service CEEGTST. Allocate enough memory for the total length of the group. You will need a pointer to this memory (the CEEGTST service returns a pointer).
 - d. Use the SET statement to establish addressability. For example, SET ADDRESS OF *group* TO *pointer*.
4. Use the unbounded table and its containing unbounded group according to the following rules:
 - You can reference unbounded tables in COBOL syntax anywhere a table can be referenced.
 - You can reference unbounded groups in COBOL syntax anywhere an alphanumeric or national group can be referenced, with the following exceptions:
 - You cannot specify unbounded groups as a BY CONTENT argument in a CALL statement.
 - You cannot specify unbounded groups as *data-name-2* on the PROCEDURE DIVISION RETURNING phrase.
 - You cannot specify unbounded groups as arguments to intrinsic functions, except as an argument to the LENGTH intrinsic function.

RELATED REFERENCES

“Example: Using unbounded tables for parsing XML documents”

Variable-length tables (*Enterprise COBOL Language Reference*)

OCCURS DEPENDING ON clause (*Enterprise COBOL Language Reference*)

Example: Using unbounded tables for parsing XML documents

Consider using unbounded tables when parsing an XML document with an unknown number of repetitive elements.

You can use any of the following methods:

- Predetermine the number of elements to expect. One method to determine the number of elements is to parse the XML document twice. During the first parse, count the number of occurrences of each unbounded element in the corresponding OCCURS UNBOUNDED DEPENDING ON object. Then, allocate storage for the data items using these computed values, and parse the XML document a second time to process its payload.
- Pick initial sizes and allow for expansion of the tables. It might be more efficient to set arbitrary limits in the OCCURS UNBOUNDED DEPENDING ON objects based on previous experience, and parse the document directly to process its content. For each unbounded element, check if the current limit is about to be exceeded. If so, allocate more storage for the corresponding array, copy the data from the old array to the expanded array, then free the storage for the old array.

The following examples illustrate the first method. See the *XML schema* example, and note that elements B and C have a maxOccurs value of unbounded, and thus can occur an unlimited number of times in the sequence within element G. In the *XML document* example, element B in fact occurs three times, and element C occurs five times.

In the *XML processing program* example, the processing procedure for the first XML PARSE statement simply computes the number of occurrences of elements B and C. After allocating the required storage, the program executes a second XML PARSE statement to process the XML payload.

XML schema

```
<?xml version="1.0" encoding="UTF-8"?>
<xsd:schema targetNamespace="http://example.org"
xmlns:xsd="http://www.w3.org/2001/XMLSchema">
<xsd:element name="G">
<xsd:complexType>
<xsd:sequence>
<xsd:element name="A" type="xsd:string" maxOccurs="1" />
<xsd:element name="B" type="xsd:int" maxOccurs="unbounded" />
<xsd:element name="C" type="xsd:int" maxOccurs="unbounded" />
</xsd:sequence>
</xsd:complexType>
</xsd:element>
</xsd:schema>
```

XML document

```
<?xml version="1.0" encoding="UTF-8"?>
<p:G xmlns:p="http://example.org" >
<A>Hello</A>
<B>1</B>
<B>2</B>
<B>3</B>
<C>1</C>
<C>2</C>
<C>3</C>
<C>4</C>
<C>5</C>
</p:G>
```

XML processing program

```
Identification division.
Program-id. XMLProc.
Data division.
Working-storage section.
01 NB pic S9(9) binary value zero.
01 NC pic S9(9) binary value zero.
```

```

01 Gptr pointer.
01 Gsize pic 9(9) binary.
01 Heap0 pic 9(9) binary value zero.
Linkage section.
01 XML-Doc pic X(500000).
01 G.
  02 A pic x(5).
  02 B pic s9(9) occurs 1 to unbounded depending on NB.
  02 C pic s9(9) occurs 1 to unbounded depending on NC.
Procedure division using XML-Doc.
XML parse XML-Doc processing procedure CountElements
Move length of G to Gsize
Call "CEEGTST" using Heap0 Gsize Gptr omitted
Set address of G to Gptr
XML parse XML-doc processing procedure acquireContent
...
Goback.
CountElements.
If xml-event = 'START-OF-ELEMENT'
  Evaluate xml-text
  When 'B'
    Add 1 to NB
  When 'C'
    Add 1 to NC
  When other
    Continue
  End-evaluate
End-if.
End program XMLProc.

```

RELATED TASKS

“Working with unbounded tables and groups” on page 90

Chapter 5. Selecting and repeating program actions

Use COBOL control language to choose program actions based on the outcome of logical tests, to iterate over selected parts of your program and data, and to identify statements to be performed as a group.

These controls include the IF, EVALUATE, and PERFORM statements, and the use of switches and flags.

RELATED TASKS

“Selecting program actions”

“Repeating program actions” on page 101

Selecting program actions

You can provide for different program actions depending on the tested value of one or more data items.

The IF and EVALUATE statements in COBOL test one or more data items by means of a conditional expression.

RELATED TASKS

“Coding a choice of actions”

“Coding conditional expressions” on page 98

RELATED REFERENCES

IF statement (*Enterprise COBOL Language Reference*)

EVALUATE statement (*Enterprise COBOL Language Reference*)

Coding a choice of actions

Use IF . . . ELSE to code a choice between two processing actions. (The word THEN is optional.) Use the EVALUATE statement to code a choice among three or more possible actions.

```
IF condition-p
  statement-1
ELSE
  statement-2
END-IF
```

When one of two processing choices is no action, code the IF statement with or without ELSE. Because the ELSE clause is optional, you can code the IF statement as follows:

```
IF condition-q
  statement-1
END-IF
```

Such coding is suitable for simple cases. For complex logic, you probably need to use the ELSE clause. For example, suppose you have nested IF statements in which there is an action for only one of the processing choices. You could use the ELSE clause and code the null branch of the IF statement with the CONTINUE statement:

```
IF condition-q
  statement-1
ELSE
  CONTINUE
END-IF
```

The EVALUATE statement is an expanded form of the IF statement that allows you to avoid nesting IF statements, a common source of logic errors and debugging problems.

RELATED TASKS

“Using nested IF statements”

“Using the EVALUATE statement” on page 95

“Coding conditional expressions” on page 98

Using nested IF statements

If an IF statement contains an IF statement as one of its possible branches, the IF statements are said to be *nested*. Theoretically, there is no limit to the depth of nested IF statements.

However, use nested IF statements sparingly. The logic can be difficult to follow, although explicit scope terminators and indentation can help. If a program has to test a variable for more than two values, EVALUATE is probably a better choice.

The following pseudocode depicts a nested IF statement:

```
IF condition-p
  IF condition-q
    statement-1
  ELSE
    statement-2
  END-IF
  statement-3
ELSE
  statement-4
END-IF
```

In the pseudocode above, an IF statement and a sequential structure are nested in one branch of the outer IF. In this structure, the END-IF that closes the nested IF is very important. Use END-IF instead of a period, because a period would end the outer IF structure also.

The following figure shows the logic structure of the pseudocode above.

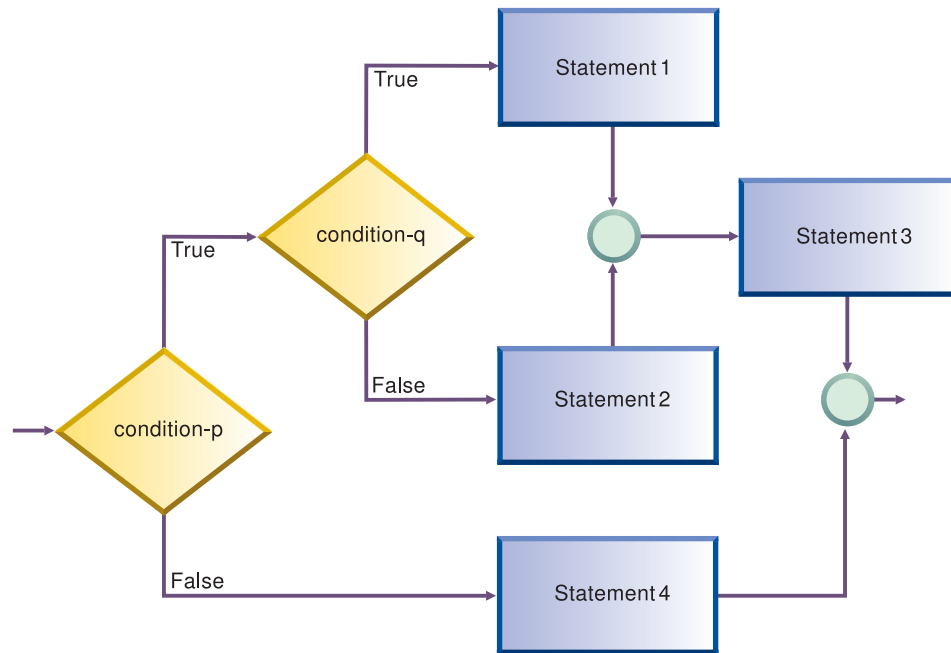

RELATED TASKS

“Coding a choice of actions” on page 93

RELATED REFERENCES

Explicit scope terminators (*Enterprise COBOL Language Reference*)

Using the EVALUATE statement

You can use the EVALUATE statement instead of a series of nested IF statements to test several conditions and specify a different action for each. Thus you can use the EVALUATE statement to implement a *case structure* or decision table.

You can also use the EVALUATE statement to cause multiple conditions to lead to the same processing, as shown in these examples:

“Example: EVALUATE using THRU phrase” on page 96

“Example: EVALUATE using multiple WHEN phrases” on page 97

In an EVALUATE statement, the operands before the WHEN phrase are referred to as *selection subjects*, and the operands in the WHEN phrase are called the *selection objects*. Selection subjects can be identifiers, literals, conditional expressions, or the word TRUE or FALSE. Selection objects can be identifiers, literals, conditional or arithmetic expressions, or the word TRUE, FALSE, or ANY.

You can separate multiple selection subjects with the ALSO phrase. You can separate multiple selection objects with the ALSO phrase. The number of selection objects within each set of selection objects must be equal to the number of selection subjects, as shown in this example:

“Example: EVALUATE testing several conditions” on page 97

Identifiers, literals, or arithmetic expressions that appear within a selection object must be valid operands for comparison to the corresponding operand in the set of selection subjects. Conditions or the word TRUE or FALSE that appear in a selection object must correspond to a conditional expression or the word TRUE or FALSE in

the set of selection subjects. (You can use the word ANY as a selection object to correspond to any type of selection subject.)

The execution of the EVALUATE statement ends when one of the following conditions occurs:

- The statements associated with the selected WHEN phrase are performed.
- The statements associated with the WHEN OTHER phrase are performed.
- No WHEN conditions are satisfied.

WHEN phrases are tested in the order that they appear in the source program. Therefore, you should order these phrases for the best performance. First code the WHEN phrase that contains selection objects that are most likely to be satisfied, then the next most likely, and so on. An exception is the WHEN OTHER phrase, which must come last.

RELATED TASKS

“Coding a choice of actions” on page 93

RELATED REFERENCES

EVALUATE statement (*Enterprise COBOL Language Reference*)

General relation conditions (*Enterprise COBOL Language Reference*)

Example: EVALUATE using THRU phrase:

This example shows how you can code several conditions in a range of values to lead to the same processing action by coding the THRU phrase. Operands in a THRU phrase must be of the same class.

In this example, CARPOOL-SIZE is the *selection subject*; 1, 2, and 3 THRU 6 are the *selection objects*:

```
EVALUATE CARPOOL-SIZE
  WHEN 1
    MOVE "SINGLE" TO PRINT-CARPOOL-STATUS
  WHEN 2
    MOVE "COUPLE" TO PRINT-CARPOOL-STATUS
  WHEN 3 THRU 6
    MOVE "SMALL GROUP" TO PRINT-CARPOOL STATUS
  WHEN OTHER
    MOVE "BIG GROUP" TO PRINT-CARPOOL STATUS
END-EVALUATE
```

The following nested IF statements represent the same logic:

```
IF CARPOOL-SIZE = 1 THEN
  MOVE "SINGLE" TO PRINT-CARPOOL-STATUS
ELSE
  IF CARPOOL-SIZE = 2 THEN
    MOVE "COUPLE" TO PRINT-CARPOOL-STATUS
  ELSE
    IF CARPOOL-SIZE >= 3 and CARPOOL-SIZE <= 6 THEN
      MOVE "SMALL GROUP" TO PRINT-CARPOOL-STATUS
    ELSE
      MOVE "BIG GROUP" TO PRINT-CARPOOL-STATUS
    END-IF
  END-IF
END-IF
```

Example: EVALUATE using multiple WHEN phrases:

The following example shows that you can code multiple WHEN phrases if several conditions should lead to the same action. Doing so gives you more flexibility than using only the THRU phrase, because the conditions do not have to evaluate to values in a range nor have the same class.

```
EVALUATE MARITAL-CODE
  WHEN "M"
    ADD 2 TO PEOPLE-COUNT
  WHEN "S"
  WHEN "D"
  WHEN "W"
    ADD 1 TO PEOPLE-COUNT
END-EVALUATE
```

The following nested IF statements represent the same logic:

```
IF MARITAL-CODE = "M" THEN
  ADD 2 TO PEOPLE-COUNT
ELSE
  IF MARITAL-CODE = "S" OR
    MARITAL-CODE = "D" OR
    MARITAL-CODE = "W" THEN
    ADD 1 TO PEOPLE-COUNT
  END-IF
END-IF
```

Example: EVALUATE testing several conditions:

This example shows the use of the ALSO phrase to separate two selection subjects (True ALSO True) and to separate the two corresponding selection objects within each set of selection objects (for example, When A + B < 10 Also C = 10).

Both selection objects in a WHEN phrase must satisfy the TRUE, TRUE condition before the associated action is performed. If both objects do not evaluate to TRUE, the next WHEN phrase is processed.

```
Identification Division.
  Program-ID. MiniEval.
Environment Division.
  Configuration Section.
  Source-Computer. IBM-390.
Data Division.
  Working-Storage Section.
  01  Age           Pic 999.
  01  Sex           Pic X.
  01  Description   Pic X(15).
  01  A             Pic 999.
  01  B             Pic 9999.
  01  C             Pic 9999.
  01  D             Pic 9999.
  01  E             Pic 99999.
  01  F             Pic 999999.
Procedure Division.
  PN01.
  Evaluate True Also True
  When Age < 13 Also Sex = "M"
    Move "Young Boy" To Description
  When Age < 13 Also Sex = "F"
    Move "Young Girl" To Description
  When Age > 12 And Age < 20 Also Sex = "M"
    Move "Teenage Boy" To Description
  When Age > 12 And Age < 20 Also Sex = "F"
    Move "Teenage Girl" To Description
  When Age > 19 Also Sex = "M"
```

```

        Move "Adult Man" To Description
    When Age > 19 Also Sex = "F"
        Move "Adult Woman" To Description
    When Other
        Move "Invalid Data" To Description
End-Evaluate
Evaluate True Also True
    When A + B < 10 Also C = 10
        Move "Case 1" To Description
    When A + B > 50 Also C = ( D + E ) / F
        Move "Case 2" To Description
    When Other
        Move "Case Other" To Description
End-Evaluate
Stop Run.

```

Coding conditional expressions

Using the IF and EVALUATE statements, you can code program actions that will be performed depending on the truth value of a conditional expression.

You can specify the following conditions:

- Relation conditions, such as:
 - Numeric comparisons
 - Alphanumeric comparisons
 - DBCS comparisons
 - National comparisons
- Class conditions; for example, to test whether a data item:
 - IS NUMERIC
 - IS ALPHABETIC
 - IS DBCS
 - IS KANJI
 - IS NOT KANJI
- Condition-name conditions, to test the value of a conditional variable that you define
- Sign conditions, to test whether a numeric operand IS POSITIVE, NEGATIVE, or ZERO
- Switch-status conditions, to test the status of UPSI switches that you name in the SPECIAL-NAMES paragraph
- Complex conditions, such as:
 - Negated conditions; for example, NOT (A IS EQUAL TO B)
 - Combined conditions (conditions combined with logical operators AND or OR)

RELATED CONCEPTS

“Switches and flags” on page 99

RELATED TASKS

“Defining switches and flags” on page 99

“Resetting switches and flags” on page 100

“Checking for incompatible data (numeric class test)” on page 54

“Comparing national (UTF-16) data” on page 147

“Testing for valid DBCS characters” on page 151

RELATED REFERENCES

General relation conditions (*Enterprise COBOL Language Reference*)

Class condition (*Enterprise COBOL Language Reference*)
Rules for condition-name entries (*Enterprise COBOL Language Reference*)
Sign condition (*Enterprise COBOL Language Reference*)
Combined conditions (*Enterprise COBOL Language Reference*)

Switches and flags

Some program decisions are based on whether the value of a data item is true or false, on or off, yes or no. Control these two-way decisions by using level-88 items with meaningful names (*condition-names*) to act as switches.

Other program decisions depend on the particular value or range of values of a data item. When you use condition-names to give more than just on or off values to a field, the field is generally referred to as a *flag*.

Flags and switches make your code easier to change. If you need to change the values for a condition, you have to change only the value of that level-88 condition-name.

For example, suppose a program uses a condition-name to test a field for a given salary range. If the program must be changed to check for a different salary range, you need to change only the value of the condition-name in the DATA DIVISION. You do not need to make changes in the PROCEDURE DIVISION.

RELATED TASKS

“Defining switches and flags”
“Resetting switches and flags” on page 100

Defining switches and flags

In the DATA DIVISION, define level-88 items that will act as switches or flags, and give them meaningful names.

To test for more than two values with flags, assign more than one condition-name to a field by using multiple level-88 items.

The reader can easily follow your code if you choose meaningful condition-names and if the values assigned to them have some association with logical values.

“Example: switches”
“Example: flags” on page 100

Example: switches

The following examples show how you can use level-88 items to test for various binary-valued (on-off) conditions in your program.

For example, to test for the end-of-file condition for an input file named Transaction-File, you can use the following data definitions:

```
WORKING-STORAGE SECTION.  
01 Switches.  
   05 Transaction-EOF-Switch Pic X value space.  
   88 Transaction-EOF      value "y".
```

The level-88 description says that a condition named Transaction-EOF is turned on when Transaction-EOF-Switch has value 'y'. Referencing Transaction-EOF in the PROCEDURE DIVISION expresses the same condition as testing Transaction-EOF-Switch = "y". For example, the following statement causes a report to be printed only if Transaction-EOF-Switch has been set to 'y':

```
If Transaction-EOF Then
    Perform Print-Report-Summary-Lines
```

Example: flags

The following examples show how you can use several level-88 items together with an EVALUATE statement to determine which of several conditions in a program is true.

Consider for example a program that updates a master file. The updates are read from a transaction file. The records in the file contain a field that indicates which of the three functions is to be performed: add, change, or delete. In the record description of the input file, code a field for the function code using level-88 items:

```
01 Transaction-Input Record
    05 Transaction-Type          Pic X.
        88 Add-Transaction      Value "A".
        88 Change-Transaction   Value "C".
        88 Delete-Transaction   Value "D".
```

The code in the PROCEDURE DIVISION for testing these condition-names to determine which function is to be performed might look like this:

```
Evaluate True
    When Add-Transaction
        Perform Add-Master-Record-Paragraph
    When Change-Transaction
        Perform Update-Existing-Record-Paragraph
    When Delete-Transaction
        Perform Delete-Master-Record-Paragraph
End-Evaluate
```

Resetting switches and flags

Throughout your program, you might need to reset switches or flags to the original values they had in their data descriptions. To do so, either use a SET statement or define a data item to move to the switch or flag.

When you use the SET *condition-name* TO TRUE statement, the switch or flag is set to the original value that it was assigned in its data description. For a level-88 item that has multiple values, SET *condition-name* TO TRUE assigns the first value (A in the example below):

```
88 Record-is-Active Value "A" "0" "S"
```

Using the SET statement and meaningful condition-names makes it easier for readers to follow your code.

“Example: set switch on”

“Example: set switch off” on page 101

Example: set switch on

The following examples show how you can set a switch on by coding a SET statement that moves the value TRUE to a level-88 item.

For example, the SET statement in the following example has the same effect as coding the statement Move "y" to Transaction-EOF-Switch:

```
01 Switches
    05 Transaction-EOF-Switch  Pic X Value space.
        88 Transaction-EOF    Value "y".
    . . .
Procedure Division.
000-Do-Main-Logic.
```

```

Perform 100-Initialize-Paragraph
Read Update-Transaction-File
  At End Set Transaction-EOF to True
End-Read

```

The following example shows how to assign a value to a field in an output record based on the transaction code of an input record:

```

01 Input-Record.
   05 Transaction-Type          Pic X(9).
01 Data-Record-Out.
   05 Data-Record-Type        Pic X.
      88 Record-Is-Active      Value "A".
      88 Record-Is-Suspended   Value "S".
      88 Record-Is-Deleted     Value "D".
   05 Key-Field                Pic X(5).
. . .
Procedure Division.
  Evaluate Transaction-Type of Input-Record
  When "ACTIVE"
    Set Record-Is-Active to TRUE
  When "SUSPENDED"
    Set Record-Is-Suspended to TRUE
  When "DELETED"
    Set Record-Is-Deleted to TRUE
  End-Evaluate

```

Example: set switch off

The following example shows how you can set a switch off by coding a MOVE statement that moves a value to a level-88 item.

For example, you can use a data item called SWITCH-OFF to set an on-off switch to off, as in the following code, which resets a switch to indicate that end-of-file has not been reached:

```

01 Switches
   05 Transaction-EOF-Switch    Pic X Value space.
      88 Transaction-EOF       Value "y".
01 SWITCH-OFF                  Pic X Value "n".
. . .
Procedure Division.
. . .
  Move SWITCH-OFF to Transaction-EOF-Switch

```

Repeating program actions

Use a PERFORM statement to repeat the same code (that is, loop) either a specified number of times or based on the outcome of a decision.

You can also use a PERFORM statement to execute a paragraph and then implicitly return control to the next executable statement. In effect, this PERFORM statement is a way of coding a closed subroutine that you can enter from many different parts of the program.

PERFORM statements can be inline or out-of-line.

RELATED TASKS

“Choosing inline or out-of-line PERFORM” on page 102

“Coding a loop” on page 103

“Looping through a table” on page 103

“Executing multiple paragraphs or sections” on page 104

Choosing inline or out-of-line PERFORM

An inline PERFORM is an imperative statement that is executed in the normal flow of a program; an out-of-line PERFORM entails a branch to a named paragraph and an implicit return from that paragraph.

To determine whether to code an inline or out-of-line PERFORM statement, answer the following questions:

- Is the PERFORM statement used in several places?
Use an out-of-line PERFORM when you want to use the same portion of code in several places in your program.
- Which placement of the statement will be easier to read?
If the code to be performed is short, an inline PERFORM can be easier to read. But if the code extends over several screens, the logical flow of the program might be clearer if you use an out-of-line PERFORM. (Each paragraph in structured programming should perform one logical function, however.)
- What are the efficiency tradeoffs?
An inline PERFORM avoids the overhead of branching that occurs with an out-of-line PERFORM. But even out-of-line PERFORM coding can improve code optimization, so efficiency gains should not be overemphasized.

In the 1974 COBOL standard, the PERFORM statement is out-of-line and thus requires a branch to a separate paragraph and an implicit return. If the performed paragraph is in the subsequent sequential flow of your program, it is also executed in that logic flow. To avoid this additional execution, place the paragraph outside the normal sequential flow (for example, after the GOBACK) or code a branch around it.

The subject of an inline PERFORM is an imperative statement. Therefore, you must code statements (other than imperative statements) within an inline PERFORM with explicit scope terminators.

“Example: inline PERFORM statement”

Example: inline PERFORM statement

This example shows the structure of an inline PERFORM statement that has the required scope terminators and the required END-PERFORM phrase.

```

Perform 100-Initialize-Paragraph
* The following statement is an inline PERFORM:
Perform Until Transaction-EOF
  Read Update-Transaction-File Into WS-Transaction-Record
  At End
  Set Transaction-EOF To True
  Not At End
  Perform 200-Edit-Update-Transaction
  If No-Errors
    Perform 300-Update-Commuter-Record
  Else
    Perform 400-Print-Transaction-Errors
* End-If is a required scope terminator
  End-If
  Perform 410-Re-Initialize-Fields
* End-Read is a required scope terminator
  End-Read
End-Perform

```

Coding a loop

Use the `PERFORM . . . TIMES` statement to execute a paragraph a specified number of times.

```
PERFORM 010-PROCESS-ONE-MONTH 12 TIMES
INSPECT . . .
```

In the example above, when control reaches the `PERFORM` statement, the code for the paragraph `010-PROCESS-ONE-MONTH` is executed 12 times before control is transferred to the `INSPECT` statement.

Use the `PERFORM . . . UNTIL` statement to execute a paragraph until a condition you choose is satisfied. You can use either of the following forms:

```
PERFORM . . . WITH TEST AFTER . . . UNTIL . . .
PERFORM . . . [WITH TEST BEFORE] . . . UNTIL . . .
```

Use the `PERFORM . . . WITH TEST AFTER . . . UNTIL` statement if you want to execute the paragraph at least once, and test before any subsequent execution. This statement is equivalent to a do-until structure:



In the following example, the implicit `WITH TEST BEFORE` phrase provides a do-while structure:

```
PERFORM 010-PROCESS-ONE-MONTH
  UNTIL MONTH GREATER THAN 12
INSPECT . . .
```

When control reaches the `PERFORM` statement, the condition `MONTH GREATER THAN 12` is tested. If the condition is satisfied, control is transferred to the `INSPECT` statement. If the condition is not satisfied, `010-PROCESS-ONE-MONTH` is executed, and the condition is tested again. This cycle continues until the condition tests as true. (To make your program easier to read, you might want to code the `WITH TEST BEFORE` clause.)

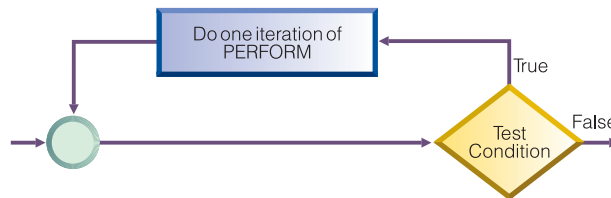

Looping through a table

You can use the `PERFORM . . . VARYING` statement to initialize a table. In this form of the `PERFORM` statement, a variable is increased or decreased and tested until a condition is satisfied.

Thus you use the `PERFORM` statement to control looping through a table. You can use either of these forms:

```
PERFORM . . . WITH TEST AFTER . . . VARYING . . . UNTIL . . .
PERFORM . . . [WITH TEST BEFORE] . . . VARYING . . . UNTIL . . .
```

The following section of code shows an example of looping through a table to check for invalid data:

```
PERFORM TEST AFTER VARYING WS-DATA-IX
    FROM 1 BY 1 UNTIL WS-DATA-IX = 12
    IF WS-DATA (WS-DATA-IX) EQUALS SPACES
        SET SERIOUS-ERROR TO TRUE
        DISPLAY ELEMENT-NUM-MSG5
    END-IF
END-PERFORM
INSPECT . . .
```

When control reaches the PERFORM statement above, WS-DATA-IX is set equal to 1 and the PERFORM statement is executed. Then the condition WS-DATA-IX = 12 is tested. If the condition is true, control drops through to the INSPECT statement. If the condition is false, WS-DATA-IX is increased by 1, the PERFORM statement is executed, and the condition is tested again. This cycle of execution and testing continues until WS-DATA-IX is equal to 12.

The loop above controls input-checking for the 12 fields of item WS-DATA. Empty fields are not allowed in the application, so the section of code loops and issues error messages as appropriate.

Executing multiple paragraphs or sections

In structured programming, you usually execute a single paragraph. However, you can execute a group of paragraphs, or a single section or group of sections, by coding the PERFORM . . . THRU statement.

When you use the PERFORM . . . THRU statement, code a paragraph-EXIT statement to clearly indicate the end point of a series of paragraphs.

RELATED TASKS

“Processing table items using intrinsic functions” on page 89

Chapter 6. Handling strings

COBOL provides language constructs for performing many different operations on string data items.

For example, you can:

- Join or split data items.
- Manipulate null-terminated strings, such as count or move characters.
- Refer to substrings by their ordinal position and, if needed, length.
- Tally and replace data items, such as count the number of times a specific character occurs in a data item.
- Convert data items, such as change to uppercase or lowercase.
- Evaluate data items, such as determine the length of a data item.

RELATED TASKS

“Joining data items (STRING)”

“Splitting data items (UNSTRING)” on page 107

“Manipulating null-terminated strings” on page 110

“Referring to substrings of data items” on page 111

“Tallying and replacing data items (INSPECT)” on page 115

“Converting data items (intrinsic functions)” on page 116

“Evaluating data items (intrinsic functions)” on page 119

Chapter 7, “Processing data in an international environment,” on page 125

Joining data items (STRING)

Use the STRING statement to join all or parts of several data items or literals into one data item. One STRING statement can take the place of several MOVE statements.

The STRING statement transfers data into a receiving data item in the order that you indicate. In the STRING statement you also specify:

- A delimiter for each set of sending fields that, if encountered, causes those sending fields to stop being transferred (DELIMITED BY phrase)
- (Optional) Action to be taken if the receiving field is filled before all of the sending data has been processed (ON OVERFLOW phrase)
- (Optional) An integer data item that indicates the leftmost character position within the receiving field into which data should be transferred (WITH POINTER phrase)

The receiving data item must not be an edited item, or a display or national floating-point item. If the receiving data item has:

- USAGE DISPLAY, each identifier in the statement except the POINTER identifier must have USAGE DISPLAY, and each literal in the statement must be alphanumeric
- USAGE NATIONAL, each identifier in the statement except the POINTER identifier must have USAGE NATIONAL, and each literal in the statement must be national
- USAGE DISPLAY-1, each identifier in the statement except the POINTER identifier must have USAGE DISPLAY-1, and each literal in the statement must be DBCS

Only that portion of the receiving field into which data is written by the STRING statement is changed.

“Example: STRING statement”

RELATED TASKS

“Handling errors in joining and splitting strings” on page 240

RELATED REFERENCES

STRING statement (*Enterprise COBOL Language Reference*)

Example: STRING statement

The following example shows the STRING statement selecting and formatting information from a record into an output line.

The FILE SECTION defines the following record:

```
01 RCD-01.
   05 CUST-INFO.
       10 CUST-NAME    PIC X(15).
       10 CUST-ADDR    PIC X(35).
   05 BILL-INFO.
       10 INV-NO       PIC X(6).
       10 INV-AMT      PIC $$,$$.99.
       10 AMT-PAID     PIC $$,$$.99.
       10 DATE-PAID    PIC X(8).
       10 BAL-DUE      PIC $$,$$.99.
       10 DATE-DUE     PIC X(8).
```

The WORKING-STORAGE SECTION defines the following fields:

```
77 RPT-LINE          PIC X(120).
77 LINE-POS          PIC S9(3).
77 LINE-NO           PIC 9(5) VALUE 1.
77 DEC-POINT         PIC X VALUE ".".
```

The record RCD-01 contains the following information (the symbol *b* indicates a blank space):

```
J.B.bSMITHbbbb
444bSPRINGbST.,bCHICAGO,bILL.bbbbb
A14275
$4,736.85
$2,400.00
09/22/76
$2,336.85
10/22/76
```

In the PROCEDURE DIVISION, these settings occur before the STRING statement:

- RPT-LINE is set to SPACES.
- LINE-POS, the data item to be used as the POINTER field, is set to 4.

Here is the STRING statement:

```
STRING
  LINE-NO SPACE CUST-INFO INV-NO SPACE DATE-DUE SPACE
  DELIMITED BY SIZE
  BAL-DUE
  DELIMITED BY DEC-POINT
  INTO RPT-LINE
  WITH POINTER LINE-POS.
```

Because the POINTER field LINE-POS has value 4 before the STRING statement is performed, data is moved into the receiving field RPT-LINE beginning at character position 4. Characters in positions 1 through 3 are unchanged.

The sending items that specify DELIMITED BY SIZE are moved in their entirety to the receiving field. Because BAL-DUE is delimited by DEC-POINT, the moving of BAL-DUE to the receiving field stops when a decimal point (the value of DEC-POINT) is encountered.

STRING results

When the STRING statement is performed, items are moved into RPT-LINE as shown in the table below.

Item	Positions
LINE-NO	4 - 8
Space	9
CUST-INFO	10 - 59
INV-NO	60 - 65
Space	66
DATE-DUE	67 - 74
Space	75
Portion of BAL-DUE that precedes the decimal point	76 - 81

After the STRING statement is performed, the value of LINE-POS is 82, and RPT-LINE has the values shown below.

Column						
	4	10		60	67	76
	↓	↓		↓	↓	↓
	00001	J.B. SMITH	444 SPRING ST., CHICAGO, ILL.	A14275	10/22/76	\$2,336

Splitting data items (UNSTRING)

Use the UNSTRING statement to split a sending field into several receiving fields. One UNSTRING statement can take the place of several MOVE statements.

In the UNSTRING statement you can specify:

- Delimiters that, when one of them is encountered in the sending field, cause the current receiving field to stop receiving and the next, if any, to begin receiving (DELIMITED BY phrase)
- A field for the delimiter that, when encountered in the sending field, causes the current receiving field to stop receiving (DELIMITER IN phrase)
- An integer data item that stores the number of characters placed in the current receiving field (COUNT IN phrase)
- An integer data item that indicates the leftmost character position within the sending field at which UNSTRING processing should begin (WITH POINTER phrase)
- An integer data item that stores a tally of the number of receiving fields that are acted on (TALLYING IN phrase)

- Action to be taken if all of the receiving fields are filled before the end of the sending data item is reached (ON OVERFLOW phrase)

The sending data item and the delimiters in the DELIMITED BY phrase must be of category alphabetic, alphanumeric, alphanumeric-edited, DBCS, national, or national-edited.

Receiving data items can be of category alphabetic, alphanumeric, numeric, DBCS, or national. If numeric, a receiving data item must be zoned decimal or national decimal. If a receiving data item has:

- USAGE DISPLAY, the sending item and each delimiter item in the statement must have USAGE DISPLAY, and each literal in the statement must be alphanumeric
- USAGE NATIONAL, the sending item and each delimiter item in the statement must have USAGE NATIONAL, and each literal in the statement must be national
- USAGE DISPLAY-1, the sending item and each delimiter item in the statement must have USAGE DISPLAY-1, and each literal in the statement must be DBCS

“Example: UNSTRING statement”

RELATED CONCEPTS

“Unicode and the encoding of language characters” on page 129

RELATED TASKS

“Handling errors in joining and splitting strings” on page 240

RELATED REFERENCES

UNSTRING statement (*Enterprise COBOL Language Reference*)

Classes and categories of data (*Enterprise COBOL Language Reference*)

Example: UNSTRING statement

The following example shows the UNSTRING statement transferring selected information from an input record. Some information is organized for printing and some for further processing.

The FILE SECTION defines the following records:

```
* Record to be acted on by the UNSTRING statement:
01 INV-RCD.
   05 CONTROL-CHARS           PIC XX.
   05 ITEM-INDENT             PIC X(20).
   05 FILLER                  PIC X.
   05 INV-CODE                PIC X(10).
   05 FILLER                  PIC X.
   05 NO-UNITS                PIC 9(6).
   05 FILLER                  PIC X.
   05 PRICE-PER-M            PIC 99999.
   05 FILLER                  PIC X.
   05 RTL-AMT                 PIC 9(6).99.
*
* UNSTRING receiving field for printed output:
01 DISPLAY-REC.
   05 INV-NO                  PIC X(6).
   05 FILLER                  PIC X VALUE SPACE.
   05 ITEM-NAME               PIC X(20).
   05 FILLER                  PIC X VALUE SPACE.
   05 DISPLAY-DOLS           PIC 9(6).
*
* UNSTRING receiving field for further processing:
01 WORK-REC.
```

```

05 M-UNITS                PIC 9(6).
05 FIELD-A                PIC 9(6).
05 WK-PRICE REDEFINES FIELD-A PIC 9999V99.
05 INV-CLASS              PIC X(3).

```

```

*
* UNSTRING statement control fields:
77 DBY-1                  PIC X.
77 CTR-1                  PIC S9(3).
77 CTR-2                  PIC S9(3).
77 CTR-3                  PIC S9(3).
77 CTR-4                  PIC S9(3).
77 DLTR-1                 PIC X.
77 DLTR-2                 PIC X.
77 CHAR-CT                PIC S9(3).
77 FLDS-FILLED            PIC S9(3).

```

In the PROCEDURE DIVISION, these settings occur before the UNSTRING statement:

- A period (.) is placed in DBY-1 for use as a delimiter.
- CHAR-CT (the POINTER field) is set to 3.
- The value zero (0) is placed in FLDS-FILLED (the TALLYING field).
- Data is read into record INV-RCD, whose format is as shown below.

Column	1	10	20	30	40	50	60
	↓	↓	↓	↓	↓	↓	↓
	ZY	FOUR-PENNY-NAILS		707890/BBA	475120	00122	000379.50

Here is the UNSTRING statement:

```

* Move subfields of INV-RCD to the subfields of DISPLAY-REC
* and WORK-REC:
UNSTRING INV-RCD
  DELIMITED BY ALL SPACES OR "/" OR DBY-1
  INTO ITEM-NAME    COUNT IN CTR-1
    INV-NO          DELIMITER IN DLTR-1  COUNT IN CTR-2
    INV-CLASS
    M-UNITS         COUNT IN CTR-3
    FIELD-A
    DISPLAY-DOLS DELIMITER IN DLTR-2  COUNT IN CTR-4
  WITH POINTER CHAR-CT
  TALLYING IN FLDS-FILLED
  ON OVERFLOW GO TO UNSTRING-COMPLETE.

```

Because the POINTER field CHAR-CT has value 3 before the UNSTRING statement is performed, the two character positions of the CONTROL-CHARS field in INV-RCD are ignored.

UNSTRING results

When the UNSTRING statement is performed, the following steps take place:

1. Positions 3 through 18 (FOUR-PENNY-NAILS) of INV-RCD are placed in ITEM-NAME, left justified in the area, and the four unused character positions are padded with spaces. The value 16 is placed in CTR-1.
2. Because ALL SPACES is coded as a delimiter, the five contiguous space characters in positions 19 through 23 are considered to be one occurrence of the delimiter.
3. Positions 24 through 29 (707890) are placed in INV-NO. The delimiter character slash (/) is placed in DLTR-1, and the value 6 is placed in CTR-2.

4. Positions 31 through 33 (BBA) are placed in INV-CLASS. The delimiter is SPACE, but because no field has been defined as a receiving area for delimiters, the space in position 34 is bypassed.
5. Positions 35 through 40 (475120) are placed in M-UNITS. The value 6 is placed in CTR-3. The delimiter is SPACE, but because no field has been defined as a receiving area for delimiters, the space in position 41 is bypassed.
6. Positions 42 through 46 (00122) are placed in FIELD-A and right justified in the area. The high-order digit position is filled with a zero (0). The delimiter is SPACE, but because no field was defined as a receiving area for delimiters, the space in position 47 is bypassed.
7. Positions 48 through 53 (000379) are placed in DISPLAY-DOLS. The period (.) delimiter in DBY-1 is placed in DLTR-2, and the value 6 is placed in CTR-4.
8. Because all receiving fields have been acted on and two characters in INV-RCD have not been examined, the ON OVERFLOW statement is executed. Execution of the UNSTRING statement is completed.

After the UNSTRING statement is performed, the fields contain the values shown below.

Field	Value
DISPLAY-REC	707890 FOUR-PENNY-NAILS 000379
WORK-REC	475120000122BBA
CHAR-CT (the POINTER field)	55
FLDS-FILLED (the TALLYING field)	6

Manipulating null-terminated strings

You can construct and manipulate null-terminated strings (for example, strings that are passed to or from a C program) by various mechanisms.

For example, you can:

- Use null-terminated literal constants (Z". . . ").
- Use an INSPECT statement to count the number of characters in a null-terminated string:

```
MOVE 0 TO char-count
INSPECT source-field TALLYING char-count
                     FOR CHARACTERS
                     BEFORE X"00"
```

- Use an UNSTRING statement to move characters in a null-terminated string to a target field, and get the character count:

```
WORKING-STORAGE SECTION.
01 source-field          PIC X(1001).
01 char-count           COMP-5 PIC 9(4).
01 target-area.
   02 individual-char OCCURS 1 TO 1000 TIMES DEPENDING ON char-count
                       PIC X.
. . .
PROCEDURE DIVISION.
   UNSTRING source-field DELIMITED BY X"00"
                       INTO target-area
                       COUNT IN char-count

   ON OVERFLOW
     DISPLAY "source not null terminated or target too short"
END-UNSTRING
```

- Use a SEARCH statement to locate trailing null or space characters. Define the string being examined as a table of single characters.
- Check each character in a field in a loop (PERFORM). You can examine each character in a field by using a reference modifier such as source-field (I:1).

“Example: null-terminated strings”

RELATED TASKS

“Handling null-terminated strings” on page 496

RELATED REFERENCES

Alphanumeric literals (*Enterprise COBOL Language Reference*)

Example: null-terminated strings

The following example shows several ways in which you can process null-terminated strings.

```

01 L pic X(20) value z'ab'.
01 M pic X(20) value z'cd'.
01 N pic X(20).
01 N-Length pic 99 value zero.
01 Y pic X(13) value 'Hello, World!'.
. . .
* Display null-terminated string:
  Inspect N tallying N-length
    for characters before initial x'00'
  Display 'N: ' N(1:N-Length) ' Length: ' N-Length
. . .
* Move null-terminated string to alphanumeric, strip null:
  Unstring N delimited by X'00' into X
. . .
* Create null-terminated string:
  String Y      delimited by size
    X'00' delimited by size
  into N.
. . .
* Concatenate two null-terminated strings to produce another:
  String L      delimited by x'00'
    M          delimited by x'00'
    X'00' delimited by size
  into N.

```

Referring to substrings of data items

Refer to a substring of a data item that has USAGE DISPLAY, DISPLAY-1, or NATIONAL by using a reference modifier. You can also refer to a substring of an alphanumeric or national character string that is returned by an intrinsic function by using a reference modifier.

Note: To get a substring of a character string argument that is encoded in UTF-8, use the USUBSTR function as described in “Using intrinsic functions to process UTF-8 encoded data” on page 142.

The following example shows how to use a reference modifier to refer to a twenty-character substring of a data item called Customer-Record:

```
Move Customer-Record(1:20) to Orig-Customer-Name
```

You code a reference modifier in parentheses immediately after the data item. As the example shows, a reference modifier can contain two values that are separated by a colon, in this order:

1. Ordinal position (from the left) of the character that you want the substring to start with
2. (Optional) Length of the required substring in *character positions*

The reference-modifier position and length for an item that has USAGE DISPLAY are expressed in terms of single-byte characters. The reference-modifier position and length for items that have USAGE DISPLAY-1 or NATIONAL are expressed in terms of DBCS character positions and national character positions, respectively.

If you omit the length in a reference modifier (coding only the ordinal position of the first character, followed by a colon), the substring extends to the end of the item. Omit the length where possible as a simpler and less error-prone coding technique.

You can refer to substrings of USAGE DISPLAY data items, including alphanumeric groups, alphanumeric-edited data items, numeric-edited data items, display floating-point data items, and zoned decimal data items, by using reference modifiers. When you reference-modify any of these data items, the result is of category alphanumeric. When you reference-modify an alphabetic data item, the result is of category alphabetic.

You can refer to substrings of USAGE NATIONAL data items, including national groups, national-edited data items, numeric-edited data items, national floating-point data items, and national decimal data items, by using reference modifiers. When you reference-modify any of these data items, the result is of category national. For example, suppose that you define a national decimal data item as follows:

```
01 NATL-DEC-ITEM Usage National Pic 999 Value 123.
```

You can use NATL-DEC-ITEM in an arithmetic expression because NATL-DEC-ITEM is of category numeric. But you cannot use NATL-DEC-ITEM(2:1) (the national character 2, which in hexadecimal notation is NX"0032") in an arithmetic expression, because it is of category national.

You can refer to substrings of table entries, including variable-length entries, by using reference modifiers. To refer to a substring of a table entry, code the subscript expression before the reference modifier. For example, assume that PRODUCT-TABLE is a properly coded table of character strings. To move D to the fourth character in the second string in the table, you can code this statement:
MOVE 'D' to PRODUCT-TABLE (2), (4:1)

You can code either or both of the two values in a reference modifier as a variable or as an arithmetic expression.

“Example: arithmetic expressions as reference modifiers” on page 114

Because numeric function identifiers can be used anywhere that arithmetic expressions can be used, you can code a numeric function identifier in a reference modifier as the leftmost character position or as the length, or both.

“Example: intrinsic functions as reference modifiers” on page 114

Each number in the reference modifier must have a value of at least 1. The sum of the two numbers must not exceed the total length of the data item by more than 1 character position so that you do not reference beyond the end of the substring.

If the leftmost character position or the length value is a fixed-point noninteger, truncation occurs to create an integer. If either is a floating-point noninteger, rounding occurs to create an integer.

The SSRANGE compiler option detects out-of-range reference modifiers, and flags violations with a runtime message.

RELATED CONCEPTS

“Reference modifiers”

“Unicode and the encoding of language characters” on page 129

RELATED TASKS

“Referring to an item in a table” on page 70

RELATED REFERENCES

“SSRANGE” on page 361

Reference modification (*Enterprise COBOL Language Reference*)

Function definitions (*Enterprise COBOL Language Reference*)

Reference modifiers

Reference modifiers let you easily refer to a substring of a data item.

For example, assume that you want to retrieve the current time from the system and display its value in an expanded format. You can retrieve the current time with the ACCEPT statement, which returns the hours, minutes, seconds, and hundredths of seconds in this format:

```
HHMMSSss
```

However, you might prefer to view the current time in this format:

```
HH:MM:SS
```

Without reference modifiers, you would have to define data items for both formats. You would also have to write code to convert from one format to the other.

With reference modifiers, you do not need to provide names for the subfields that describe the TIME elements. The only data definition you need is for the time as returned by the system. For example:

```
01 REFMOD-TIME-ITEM PIC X(8).
```

The following code retrieves and expands the time value:

```
ACCEPT REFMOD-TIME-ITEM FROM TIME.
DISPLAY "CURRENT TIME IS: "
* Retrieve the portion of the time value that corresponds to
* the number of hours:
REFMOD-TIME-ITEM (1:2)
":"
* Retrieve the portion of the time value that corresponds to
* the number of minutes:
REFMOD-TIME-ITEM (3:2)
":"
* Retrieve the portion of the time value that corresponds to
* the number of seconds:
REFMOD-TIME-ITEM (5:2)
```

“Example: arithmetic expressions as reference modifiers” on page 114

“Example: intrinsic functions as reference modifiers” on page 114

RELATED TASKS

“Assigning input from a screen or file (ACCEPT)” on page 34
“Referring to substrings of data items” on page 111
“Using national data (Unicode) in COBOL” on page 130

RELATED REFERENCES

Reference modification (*Enterprise COBOL Language Reference*)

Example: arithmetic expressions as reference modifiers

Suppose that a field contains some right-justified characters, and you want to move those characters to another field where they will be left justified. You can do so by using reference modifiers and an INSPECT statement.

Suppose a program has the following data:

```
01 LEFTY      PIC X(30).  
01 RIGHTY    PIC X(30) JUSTIFIED RIGHT.  
01 I         PIC 9(9)  USAGE BINARY.
```

The program counts the number of leading spaces and, using arithmetic expressions in a reference modifier, moves the right-justified characters into another field, justified to the left:

```
MOVE SPACES TO LEFTY  
MOVE ZERO TO I  
INSPECT RIGHTY  
    TALLYING I FOR LEADING SPACE.  
IF I IS LESS THAN LENGTH OF RIGHTY THEN  
    MOVE RIGHTY ( I + 1 : LENGTH OF RIGHTY - I ) TO LEFTY  
END-IF
```

The MOVE statement transfers characters from RIGHTY, beginning at the position computed as I + 1 for a length that is computed as LENGTH OF RIGHTY - I, into the field LEFTY.

Example: intrinsic functions as reference modifiers

You can use intrinsic functions in reference modifiers if you do not know the leftmost position or length of a substring at compile time.

For example, the following code fragment causes a substring of Customer-Record to be moved into the data item WS-name. The substring is determined at run time.

```
05 WS-name      Pic x(20).  
05 Left-posn    Pic 99.  
05 I           Pic 99.  
.  
.  
.  
Move Customer-Record(Function Min(Left-posn I):Function Length(WS-name)) to WS-name
```

If you want to use a noninteger function in a position that requires an integer function, you can use the INTEGER or INTEGER-PART function to convert the result to an integer. For example:

```
Move Customer-Record(Function Integer(Function Sqrt(I)): ) to WS-name
```

RELATED REFERENCES

INTEGER (*Enterprise COBOL Language Reference*)

INTEGER-PART (*Enterprise COBOL Language Reference*)

Tallying and replacing data items (INSPECT)

Use the INSPECT statement to inspect characters or groups of characters in a data item and to optionally replace them.

Use the INSPECT statement to do the following tasks:

- Count the number of times a specific character occurs in a data item (TALLYING phrase).
- Fill a data item or selected portions of a data item with specified characters such as spaces, asterisks, or zeros (REPLACING phrase).
- Convert all occurrences of a specific character or string of characters in a data item to replacement characters that you specify (CONVERTING phrase).

You can specify one of the following data items as the item to be inspected:

- An elementary item described explicitly or implicitly as USAGE DISPLAY, USAGE DISPLAY-1, or USAGE NATIONAL
- An alphanumeric group item or national group item

If the inspected item has:

- USAGE DISPLAY, each identifier in the statement (except the TALLYING count field) must have USAGE DISPLAY, and each literal in the statement must be alphanumeric
- USAGE NATIONAL, each identifier in the statement (except the TALLYING count field) must have USAGE NATIONAL, and each literal in the statement must be national
- USAGE DISPLAY-1, each identifier in the statement (except the TALLYING count field) must have USAGE DISPLAY-1, and each literal in the statement must be a DBCS literal

“Examples: INSPECT statement”

RELATED CONCEPTS

“Unicode and the encoding of language characters” on page 129

RELATED REFERENCES

INSPECT statement (*Enterprise COBOL Language Reference*)

Examples: INSPECT statement

The following examples show some uses of the INSPECT statement to examine and replace characters.

In the following example, the INSPECT statement examines and replaces characters in data item DATA-2. The number of times a leading zero (0) occurs in the data item is accumulated in COUNTR. The first instance of the character A that follows the first instance of the character C is replaced by the character 2.

```
77 COUNTR          PIC 9   VALUE ZERO.
01 DATA-2        PIC X(11).
. . .
  INSPECT DATA-2
    TALLYING COUNTR FOR LEADING "0"
    REPLACING FIRST "A" BY "2" AFTER INITIAL "C"
```

DATA-2 before	COUNTR after	DATA-2 after
00ACADEMY00	2	00AC2DEMY00

DATA-2 before	COUNTR after	DATA-2 after
0000ALABAMA	4	0000ALABAMA
CHATHAM0000	0	CH2THAM0000

In the following example, the INSPECT statement examines and replaces characters in data item DATA-3. Each character that precedes the first instance of a quotation mark (") is replaced by the character 0.

```

77 COUNTR          PIC 9  VALUE ZERO.
01 DATA-3        PIC X(8).
. . .
  INSPECT DATA-3
    REPLACING CHARACTERS BY ZEROS BEFORE INITIAL QUOTE

```

DATA-3 before	COUNTR after	DATA-3 after
456"ABEL	0	000"ABEL
ANDES"12	0	00000"12
"Twas BR	0	"Twas BR

The following example shows the use of INSPECT CONVERTING with AFTER and BEFORE phrases to examine and replace characters in data item DATA-4. All characters that follow the first instance of the character / but that precede the first instance of the character ? (if any) are translated from lowercase to uppercase.

```

01 DATA-4        PIC X(11).
. . .
  INSPECT DATA-4
    CONVERTING
      "abcdefghijklmnopqrstuvwxyz" TO
      "ABCDEFGHIJKLMNOPQRSTUVWXYZ"
    AFTER INITIAL "/"
    BEFORE INITIAL "?"

```

DATA-4 before	DATA-4 after
a/five/?six	a/FIVE/?six
r/Rexx/RRRr	r/REXX/RRRR
zfour?inspe	zfour?inspe

Converting data items (intrinsic functions)

You can use intrinsic functions to convert character-string data items to several other formats, for example, to uppercase or lowercase, to reverse order, to numbers, or to one code page from another.

You can use the NATIONAL-OF and DISPLAY-OF intrinsic functions to convert to and from national (Unicode) strings.

You can also use the INSPECT statement to convert characters.

“Examples: INSPECT statement” on page 115

RELATED TASKS

“Changing case (UPPER-CASE, LOWER-CASE)” on page 117

“Transforming to reverse order (REVERSE)” on page 117

“Converting to numbers (NUMVAL, NUMVAL-C)”
“Converting from one code page to another” on page 118

Changing case (UPPER-CASE, LOWER-CASE)

You can use the UPPER-CASE and LOWER-CASE intrinsic functions to easily change the case of alphanumeric, alphabetic, or national strings.

```
01 Item-1 Pic x(30) Value "Hello World!".  
01 Item-2 Pic x(30).  
.  
. . .  
  Display Item-1  
  Display Function Upper-case(Item-1)  
  Display Function Lower-case(Item-1)  
  Move Function Upper-case(Item-1) to Item-2  
  Display Item-2
```

The code above displays the following messages on the system logical output device:

```
Hello World!  
HELLO WORLD!  
hello world!  
HELLO WORLD!
```

The DISPLAY statements do not change the actual contents of Item-1, but affect only how the letters are displayed. However, the MOVE statement causes uppercase letters to replace the contents of Item-2.

Note: The UPPER-CASE and LOWER-CASE intrinsic functions do not support alphanumeric arguments that contain UTF-8 encoded data.

RELATED TASKS

“Assigning input from a screen or file (ACCEPT)” on page 34
“Displaying values on a screen or in a file (DISPLAY)” on page 35

Transforming to reverse order (REVERSE)

You can reverse the order of the characters in a string by using the REVERSE intrinsic function.

```
Move Function Reverse(Orig-cust-name) To Orig-cust-name
```

For example, the statement above reverses the order of the characters in Orig-cust-name. If the starting value is JOHNSONbbb, the value after the statement is performed is bbbNOSNH0J, where *b* represents a blank space.

RELATED CONCEPTS

“Unicode and the encoding of language characters” on page 129

Converting to numbers (NUMVAL, NUMVAL-C)

The NUMVAL and NUMVAL-C functions convert character strings (alphanumeric or national literals, or class alphanumeric or class national data items) to numbers. Use these functions to convert free-format character-representation numbers to numeric form so that you can process them numerically.

```
01 R      Pic x(20) Value "- 1234.5678".  
01 S      Pic x(20) Value " $12,345.67CR".  
01 Total  Usage is Comp-1.  
.  
. . .  
  Compute Total = Function Numval(R) + Function Numval-C(S)
```

Use NUMVAL-C when the argument includes a currency symbol or comma or both, as shown in the example above. You can also place an algebraic sign before or after the character string, and the sign will be processed. The arguments must not exceed 18 digits when you compile with the default option ARITH(COMPAT) (*compatibility mode*) nor 31 digits when you compile with ARITH(EXTEND) (*extended mode*), not including the editing symbols.

NUMVAL and NUMVAL-C return long (64-bit) floating-point values in compatibility mode, and return extended-precision (128-bit) floating-point values in extended mode. A reference to either of these functions represents a reference to a numeric data item.

At most 15 decimal digits can be converted accurately to long-precision floating point (as described in the related reference below about conversions and precision). If the argument to NUMVAL or NUMVAL-C has more than 15 digits, it is recommended that you specify the ARITH(EXTEND) compiler option so that an extended-precision function result that can accurately represent the value of the argument is returned.

When you use NUMVAL or NUMVAL-C, you do not need to statically define numeric data in a fixed format nor input data in a precise manner. For example, suppose you define numbers to be entered as follows:

```
01 X   Pic S999V99  leading sign is separate.
. . .
      Accept X from Console
```

The user of the application must enter the numbers exactly as defined by the PICTURE clause. For example:

```
+001.23
-300.00
```

However, using the NUMVAL function, you could code:

```
01 A   Pic x(10).
01 B   Pic S999V99.
. . .
      Accept A from Console
      Compute B = Function Numval(A)
```

The input could then be:

```
1.23
-300
```

RELATED CONCEPTS

“Formats for numeric data” on page 47

“Data format conversions” on page 52

“Unicode and the encoding of language characters” on page 129

RELATED TASKS

“Converting to or from national (Unicode) representation” on page 137

RELATED REFERENCES

“Conversions and precision” on page 52

“ARITH” on page 309

Converting from one code page to another

You can nest the DISPLAY-OF and NATIONAL-OF intrinsic functions to easily convert from any code page to any other code page.

For example, the following code converts an EBCDIC string to an ASCII string:

```
77 EBCDIC-CCSID PIC 9(4) BINARY VALUE 1140.
77 ASCII-CCSID PIC 9(4) BINARY VALUE 819.
77 Input-EBCDIC PIC X(80).
77 ASCII-Output PIC X(80).
. . .
* Convert EBCDIC to ASCII
  Move Function Display-of
    (Function National-of (Input-EBCDIC EBCDIC-CCSID),
     ASCII-CCSID)
  to ASCII-output
```

RELATED CONCEPTS

“Unicode and the encoding of language characters” on page 129

RELATED TASKS

“Converting to or from national (Unicode) representation” on page 137

Evaluating data items (intrinsic functions)

You can use intrinsic functions to determine the ordinal position of a character in the collating sequence, to find the largest or smallest item in a series, to find the length of data item, or to determine when a program was compiled.

Use these intrinsic functions:

- CHAR and ORD to evaluate integers and single alphabetic or alphanumeric characters with respect to the collating sequence used in a program
- MAX, MIN, ORD-MAX, and ORD-MIN to find the largest and smallest items in a series of data items, including USAGE NATIONAL data items
- LENGTH to find the length of data items, including USAGE NATIONAL data items
- WHEN-COMPILED to find the date and time when a program was compiled

RELATED CONCEPTS

“Unicode and the encoding of language characters” on page 129

RELATED TASKS

“Evaluating single characters for collating sequence”
“Finding the largest or smallest data item” on page 120
“Finding the length of data items” on page 122
“Finding the date of compilation” on page 123

Evaluating single characters for collating sequence

To find out the ordinal position of a given alphabetic or alphanumeric character in the collating sequence, use the ORD function with the character as the argument. ORD returns an integer that represents that ordinal position.

You can use a one-character substring of a data item as the argument to ORD:

```
IF Function Ord(Customer-record(1:1)) IS > 194 THEN . . .
```

If you know the ordinal position in the collating sequence of a character, and want to find the character that it corresponds to, use the CHAR function with the integer ordinal position as the argument. CHAR returns the required character. For example:

```
INITIALIZE Customer-Name REPLACING ALPHABETIC BY Function Char(65)
```

RELATED REFERENCES

CHAR (*Enterprise COBOL Language Reference*)

ORD (*Enterprise COBOL Language Reference*)

Finding the largest or smallest data item

To determine which of two or more alphanumeric, alphabetic, or national data items has the largest value, use the MAX or ORD-MAX intrinsic function. To determine which item has the smallest value, use MIN or ORD-MIN. These functions evaluate according to the collating sequence.

To compare numeric items, including those that have USAGE NATIONAL, you can use MAX, ORD-MAX, MIN, or ORD-MIN. With these intrinsic functions, the algebraic values of the arguments are compared.

The MAX and MIN functions return the content of one of the arguments that you supply. For example, suppose that your program has the following data definitions:

```
05 Arg1 Pic x(10) Value "THOMASSON ".
05 Arg2 Pic x(10) Value "THOMAS   ".
05 Arg3 Pic x(10) Value "VALLEJO  ".
```

The following statement assigns VALLEJ0bbb to the first 10 character positions of Customer-record, where *b* represents a blank space:

```
Move Function Max(Arg1 Arg2 Arg3) To Customer-record(1:10)
```

If you used MIN instead, then THOMASbbbb would be assigned.

The functions ORD-MAX and ORD-MIN return an integer that represents the ordinal position (counting from the left) of the argument that has the largest or smallest value in the list of arguments that you supply. If you used the ORD-MAX function in the previous example, the compiler would issue an error message because the reference to a numeric function is not in a valid place. Using the same arguments as in the previous example, ORD-MAX can be used as follows:

```
Compute x = Function Ord-max(Arg1 Arg2 Arg3)
```

The statement above assigns the integer 3 to *x* if the same arguments are used as in the previous example. If you used ORD-MIN instead, the integer 2 would be returned. The examples above might be more realistic if Arg1, Arg2, and Arg3 were successive elements of an array (table).

If you specify a national item for any argument, you must specify all arguments as class national.

RELATED TASKS

“Performing arithmetic” on page 56

“Processing table items using intrinsic functions” on page 89

“Returning variable results with alphanumeric or national functions” on page 121

RELATED REFERENCES

MAX (*Enterprise COBOL Language Reference*)

MIN (*Enterprise COBOL Language Reference*)

ORD-MAX (*Enterprise COBOL Language Reference*)

ORD-MIN (*Enterprise COBOL Language Reference*)

Returning variable results with alphanumeric or national functions

The results of alphanumeric or national functions could be of varying lengths and values depending on the function arguments.

In the following example, the amount of data moved to R3 and the results of the COMPUTE statement depend on the values and sizes of R1 and R2:

```
01 R1    Pic x(10) value "e".
01 R2    Pic x(05) value "f".
01 R3    Pic x(20) value spaces.
01 L     Pic 99.
. . .
    Move Function Max(R1 R2) to R3
    Compute L = Function Length(Function Max(R1 R2))
```

This code has the following results:

- R2 is evaluated to be larger than R1.
- The string 'fbbb' is moved to R3, where *b* represents a blank space. (The unfilled character positions in R3 are padded with spaces.)
- L evaluates to the value 5.

If R1 contained 'g' instead of 'e', the code would have the following results:

- R1 would evaluate as larger than R2.
- The string 'gbbbbbbb' would be moved to R3. (The unfilled character positions in R3 would be padded with spaces.)
- The value 10 would be assigned to L.

If a program uses national data for function arguments, the lengths and values of the function results could likewise vary. For example, the following code is identical to the fragment above, but uses national data instead of alphanumeric data.

```
01 R1    Pic n(10) national value "e".
01 R2    Pic n(05) national value "f".
01 R3    Pic n(20) national value spaces.
01 L     Pic 99    national.
. . .
    Move Function Max(R1 R2) to R3
    Compute L = Function Length(Function Max(R1 R2))
```

This code has the following results, which are similar to the first set of results except that these are for national characters:

- R2 is evaluated to be larger than R1.
- The string NX"0066 0020 0020 0020 0020" (the equivalent in national characters of 'fbbb', where *b* represents a blank space), shown here in hexadecimal notation with added spaces for readability, is moved to R3. The unfilled character positions in R3 are padded with national spaces.
- L evaluates to the value 5, the length in national character positions of R2.

You might be dealing with variable-length output from alphanumeric or national functions. Plan your program accordingly. For example, you might need to think about using variable-length files when the records that you are writing could be of different lengths:

```
File Section.
FD Output-File Recording Mode V.
01 Short-Customer-Record Pic X(50).
01 Long-Customer-Record  Pic X(70).
```

```

Working-Storage Section.
01 R1    Pic x(50).
01 R2    Pic x(70).
. . .
  If R1 > R2
    Write Short-Customer-Record from R1
  Else
    Write Long-Customer-Record from R2
  End-if

```

RELATED TASKS

“Finding the largest or smallest data item” on page 120
 “Performing arithmetic” on page 56

RELATED REFERENCES

MAX (*Enterprise COBOL Language Reference*)

Finding the length of data items

You can use the LENGTH function in many contexts (including tables and numeric data) to determine the length of an item. For example, you can use the LENGTH function to determine the length of an alphanumeric or national literal, or a data item of any type except DBCS.

The LENGTH function returns the length of a national item (a literal, or any item that has USAGE NATIONAL, including national group items) as an integer equal to the length of the argument in national character positions. It returns the length of any other data item as an integer equal to the length of the argument in alphanumeric character positions.

The following COBOL statement demonstrates moving a data item into the field in a record that holds customer names:

```
Move Customer-name To Customer-record(1:Function Length(Customer-name))
```

You can also use the LENGTH OF special register, which returns the length in bytes even for national data. Coding either Function Length(Customer-name) or LENGTH OF Customer-name returns the same result for alphanumeric items: the length of Customer-name in bytes.

You can use the LENGTH function only where arithmetic expressions are allowed. However, you can use the LENGTH OF special register in a greater variety of contexts. For example, you can use the LENGTH OF special register as an argument to an intrinsic function that accepts integer arguments. (You cannot use an intrinsic function as an operand to the LENGTH OF special register.) You can also use the LENGTH OF special register as a parameter in a CALL statement.

RELATED TASKS

“Performing arithmetic” on page 56
 “Creating variable-length tables (DEPENDING ON)” on page 78
 “Processing table items using intrinsic functions” on page 89

RELATED REFERENCES

LENGTH (*Enterprise COBOL Language Reference*)
 LENGTH OF (*Enterprise COBOL Language Reference*)

Finding the date of compilation

You can use the `WHEN-COMPILED` intrinsic function to determine when a program was compiled. The 21-character result indicates the four-digit year, month, day, and time (in hours, minutes, seconds, and hundredths of seconds) of compilation, and the difference in hours and minutes from Greenwich mean time.

The first 16 positions are in the following format:

YYYYMMDDhhmmsshh

You can instead use the `WHEN-COMPILED` special register to determine the date and time of compilation in the following format:

MM/DD/YYhh.mm.ss

The `WHEN-COMPILED` special register supports only a two-digit year, and does not carry fractions of a second. You can use this special register only as the sending field in a `MOVE` statement.

RELATED REFERENCES

`WHEN-COMPILED` (*Enterprise COBOL Language Reference*)

Chapter 7. Processing data in an international environment

Enterprise COBOL supports Unicode UTF-16 as national character data at run time. UTF-16 provides a consistent and efficient way to encode plain text. Using UTF-16, you can develop software that will work with various national languages.

Use these COBOL facilities to code and compile programs that process national data:

- Data types and literals:
 - Character data types, defined with the `USAGE NATIONAL` clause and a `PICTURE` clause that defines data of category national, national-edited, or numeric-edited
 - Numeric data types, defined with the `USAGE NATIONAL` clause and a `PICTURE` clause that defines a numeric data item (a *national decimal item*) or an external floating-point data item (a *national floating-point item*)
 - National literals, specified with literal prefix `N` or `NX`
 - Figurative constant `ALL` *national-literal*
 - Figurative constants `QUOTE`, `SPACE`, `HIGH-VALUE`, `LOW-VALUE`, or `ZERO`, which have national character (UTF-16) values when used in national-character contexts
- The COBOL statements shown in the related reference below about COBOL statements and national data
- Intrinsic functions:
 - `NATIONAL-OF` to convert an alphanumeric or double-byte character set (DBCS) character string to `USAGE NATIONAL` (UTF-16)
 - `DISPLAY-OF` to convert a national character string to `USAGE DISPLAY` in a selected code page (EBCDIC, ASCII, EUC, or UTF-8)
 - The other intrinsic functions shown in the related reference below about intrinsic functions and national data
- The `GROUP-USAGE NATIONAL` clause to define groups that contain only `USAGE NATIONAL` data items and that behave like elementary category national items in most operations
- Compiler options:
 - `CODEPAGE` to specify the code page to use for alphanumeric and DBCS data in your program
 - `NSYMBOL` to control whether national or DBCS processing is used for the `N` symbol in literals and `PICTURE` clauses

You can also take advantage of implicit conversions of alphanumeric or DBCS data items to national representation. The compiler performs such conversions (in most cases) when you move these items to national data items, or compare these items with national data items.

RELATED CONCEPTS

“Unicode and the encoding of language characters” on page 129

“National groups” on page 133

RELATED TASKS

“Using national data (Unicode) in COBOL” on page 130

“Converting to or from national (Unicode) representation” on page 137

“Processing UTF-8 data” on page 141
 “Processing Chinese GB 18030 data” on page 146
 “Comparing national (UTF-16) data” on page 147
 “Coding for use of DBCS support” on page 150
 Appendix B, “Converting double-byte character set (DBCS) data,” on page 695

RELATED REFERENCES

“COBOL statements and national data”
 “Intrinsic functions and national data” on page 128
 “CODEPAGE” on page 313
 “NSYMBOL” on page 340
 Classes and categories of data (*Enterprise COBOL Language Reference*)
 Data categories and PICTURE rules (*Enterprise COBOL Language Reference*)
 MOVE statement (*Enterprise COBOL Language Reference*)
 General relation conditions (*Enterprise COBOL Language Reference*)

COBOL statements and national data

You can use national data with the PROCEDURE DIVISION and compiler-directing statements shown in the table below.

Table 15. COBOL statements and national data

COBOL statement	Can be national	Comment	For more information
ACCEPT	<i>identifier-1, identifier-2</i>	<i>identifier-1</i> is converted from the native code page specified in the CODEPAGE compiler option only if input is from CONSOLE.	“Assigning input from a screen or file (ACCEPT)” on page 34
ADD	All identifiers can be numeric items that have USAGE NATIONAL. <i>identifier-3</i> (GIVING) can be numeric-edited with USAGE NATIONAL.		“Using COMPUTE and other arithmetic statements” on page 56
CALL	<i>identifier-2, identifier-3, identifier-4, identifier-5; literal-2, literal-3</i>		“Passing data” on page 491
COMPUTE	<i>identifier-1</i> can be numeric or numeric-edited with USAGE NATIONAL. <i>arithmetic-expression</i> can contain numeric items that have USAGE NATIONAL.		“Using COMPUTE and other arithmetic statements” on page 56
COPY . . . REPLACING	<i>operand-1, operand-2</i> of the REPLACING phrase		Chapter 18, “Compiler-directing statements,” on page 381
DISPLAY	<i>identifier-1</i>	<i>identifier-1</i> is converted to EBCDIC only if the CONSOLE mnemonic-name is specified directly or indirectly.	“Displaying values on a screen or in a file (DISPLAY)” on page 35

Table 15. COBOL statements and national data (continued)

COBOL statement	Can be national	Comment	For more information
DIVIDE	All identifiers can be numeric items that have USAGE NATIONAL. <i>identifier-3</i> (GIVING) and <i>identifier-4</i> (REMAINDER) can be numeric-edited with USAGE NATIONAL.		"Using COMPUTE and other arithmetic statements" on page 56
INITIALIZE	<i>identifier-1</i> ; <i>identifier-2</i> or <i>literal-1</i> of the REPLACING phrase	If you specify REPLACING NATIONAL or REPLACING NATIONAL-EDITED, <i>identifier-2</i> or <i>literal-1</i> must be valid as a sending operand in a move to <i>identifier-1</i> .	"Examples: initializing data items" on page 28
INSPECT	All identifiers and literals. (<i>identifier-2</i> , the TALLYING integer data item, can have USAGE NATIONAL.)	If any of these (other than <i>identifier-2</i> , the TALLYING identifier) have USAGE NATIONAL, all must be national.	"Tallying and replacing data items (INSPECT)" on page 115
INVOKE	Method-name as <i>identifier-2</i> or <i>literal-1</i> ; <i>identifier-3</i> or <i>literal-2</i> in the BY VALUE phrase		"Invoking methods (INVOKE)" on page 610
MERGE	Merge keys	The COLLATING SEQUENCE phrase does not apply.	"Setting sort or merge criteria" on page 227
MOVE	Both the sender and receiver, or only the receiver	Implicit conversions are performed for valid MOVE operands.	"Assigning values to elementary data items (MOVE)" on page 32 "Assigning values to group data items (MOVE)" on page 33
MULTIPLY	All identifiers can be numeric items that have USAGE NATIONAL. <i>identifier-3</i> (GIVING) can be numeric-edited with USAGE NATIONAL.		"Using COMPUTE and other arithmetic statements" on page 56
SEARCH ALL (binary search)	Both the key data item and its object of comparison	The key data item and its object of comparison must be compatible according to the rules of comparison. If the object of comparison is of class national, the key must be also.	"Doing a binary search (SEARCH ALL)" on page 87
SORT	Sort keys	The COLLATING SEQUENCE phrase does not apply.	"Setting sort or merge criteria" on page 227
STRING	All identifiers and literals. (<i>identifier-4</i> , the POINTER integer data item, can have USAGE NATIONAL.)	If <i>identifier-3</i> , the receiving data item, is national, all identifiers and literals (other than <i>identifier-4</i> , the POINTER identifier) must be national.	"Joining data items (STRING)" on page 105

Table 15. COBOL statements and national data (continued)

COBOL statement	Can be national	Comment	For more information
SUBTRACT	All identifiers can be numeric items that have USAGE NATIONAL. <i>identifier-3</i> (GIVING) can be numeric-edited with USAGE NATIONAL.		"Using COMPUTE and other arithmetic statements" on page 56
UNSTRING	All identifiers and literals. (<i>identifier-6</i> and <i>identifier-7</i> , the COUNT and TALLYING integer data items, respectively, can have USAGE NATIONAL.)	If <i>identifier-4</i> , a receiving data item, has USAGE NATIONAL, the sending data item and each delimiter must have USAGE NATIONAL, and each literal must be national.	"Splitting data items (UNSTRING)" on page 107
XML GENERATE	<i>identifier-1</i> (the generated XML document); <i>identifier-2</i> (the source field or fields); <i>identifier-4</i> or <i>literal-4</i> (the namespace identifier); <i>identifier-5</i> or <i>literal-5</i> (the namespace prefix)		Chapter 29, "Producing XML output," on page 571
XML PARSE	<i>identifier-1</i> (the XML document)	The XML-NTEXT special register contains national character document fragments during parsing. XML-NNAMESPACE and XML-NNAMESPACE-PREFIX special registers contain the associated namespace identifier and namespace prefix, if any, in national characters.	Chapter 28, "Processing XML input," on page 527

RELATED TASKS

- "Defining numeric data" on page 43
- "Displaying numeric data" on page 45
- "Using national data (Unicode) in COBOL" on page 130
- "Comparing national (UTF-16) data" on page 147

RELATED REFERENCES

- "CODEPAGE" on page 313
- Classes and categories of data (*Enterprise COBOL Language Reference*)

Intrinsic functions and national data

You can use arguments of class national with the intrinsic functions shown in the table below.

Table 16. Intrinsic functions and national character data

Intrinsic function	Function type	For more information
DISPLAY-OF	Alphanumeric	"Converting national to alphanumeric (DISPLAY-OF)" on page 139
LENGTH	Integer	"Finding the length of data items" on page 122

Table 16. Intrinsic functions and national character data (continued)

Intrinsic function	Function type	For more information
LOWER-CASE, UPPER-CASE	National	“Changing case (UPPER-CASE, LOWER-CASE)” on page 117
NUMVAL, NUMVAL-C	Numeric	“Converting to numbers (NUMVAL, NUMVAL-C)” on page 117
MAX, MIN	National	“Finding the largest or smallest data item” on page 120
ORD-MAX, ORD-MIN	Integer	“Finding the largest or smallest data item” on page 120
REVERSE	National	“Transforming to reverse order (REVERSE)” on page 117

You can use national decimal arguments wherever zoned decimal arguments are allowed. You can use national floating-point arguments wherever display floating-point arguments are allowed. (See the related reference below about arguments for a complete list of intrinsic functions that can take integer or numeric arguments.)

RELATED TASKS

“Defining numeric data” on page 43

“Using national data (Unicode) in COBOL” on page 130

RELATED REFERENCES

Arguments (*Enterprise COBOL Language Reference*)

Classes and categories of data (*Enterprise COBOL Language Reference*)

Unicode and the encoding of language characters

Enterprise COBOL provides basic runtime support for Unicode, which can handle tens of thousands of characters that cover all commonly used characters and symbols in the world.

A *character set* is a defined set of characters, but is not associated with a coded representation. A *coded character set* (also referred to in this documentation as a *code page*) is a set of unambiguous rules that relate the characters of the set to their coded representation. Each code page has a name and is like a table that sets up the symbols for representing a character set; each symbol is associated with a unique bit pattern, or *code point*. Each code page also has a *coded character set identifier (CCSID)*, which is a value from 1 to 65,536.

Unicode has several encoding schemes, called *Unicode Transformation Format (UTF)*, such as UTF-8, UTF-16, and UTF-32. Enterprise COBOL uses UTF-16 (CCSID 1200) in big-endian format as the representation for national literals and data items that have USAGE NATIONAL.

UTF-8 represents ASCII invariant characters a-z, A-Z, 0-9, and certain special characters such as ' @ , . + - = / * () the same way that they are represented in ASCII. UTF-16 represents these characters as NX'00nn', where X'nn' is the representation of the character in ASCII.

For example, the string 'ABC' is represented in UTF-16 as NX'004100420043'. In UTF-8, 'ABC' is represented as X'414243'.

One or more *encoding units* are used to represent a character from a coded character set. For UTF-16, an encoding unit takes 2 bytes of storage. Any character

defined in any EBCDIC, ASCII, or EUC code page is represented in one UTF-16 encoding unit when the character is converted to the national data representation.

Cross-platform considerations: Enterprise COBOL and COBOL for AIX® support UTF-16 in big-endian format in national data. COBOL for Windows supports UTF-16 in little-endian format (UTF-16LE) in national data. If you are porting Unicode data that is encoded in UTF-16LE representation to Enterprise COBOL from another platform, you must convert that data to UTF-16 in big-endian format to process the data as national data.

RELATED TASKS

“Converting to or from national (Unicode) representation” on page 137

RELATED REFERENCES

“Storage of character data” on page 137

Character sets and code pages (*Enterprise COBOL Language Reference*)

Using national data (Unicode) in COBOL

In Enterprise COBOL, you can specify national (UTF-16) data in any of several ways.

These types of national data are available:

- National data items (categories national, national-edited, and numeric-edited)
- National literals
- Figurative constants as national characters
- Numeric data items (national decimal and national floating-point)

In addition, you can define national groups that contain only data items that explicitly or implicitly have `USAGE NATIONAL`, and that behave in the same way as elementary category national data items in most operations.

These declarations affect the amount of storage that is needed.

RELATED CONCEPTS

“Unicode and the encoding of language characters” on page 129

“National groups” on page 133

RELATED TASKS

“Defining national data items”

“Using national literals” on page 131

“Using national-character figurative constants” on page 132

“Defining national numeric data items” on page 133

“Using national groups” on page 134

“Converting to or from national (Unicode) representation” on page 137

“Comparing national (UTF-16) data” on page 147

RELATED REFERENCES

“Storage of character data” on page 137

Classes and categories of data (*Enterprise COBOL Language Reference*)

Defining national data items

Define national data items with the `USAGE NATIONAL` clause to hold national (UTF-16) character strings.

You can define national data items of the following categories:

- National
- National-edited
- Numeric-edited

To define a category national data item, code a PICTURE clause that contains only one or more PICTURE symbols N.

To define a national-edited data item, code a PICTURE clause that contains at least one of each of the following symbols:

- Symbol N
- Simple insertion editing symbol B, 0, or /

To define a numeric-edited data item of class national, code a PICTURE clause that defines a numeric-edited item (for example, `-$999.99`) and code a USAGE NATIONAL clause. You can use a numeric-edited data item that has USAGE NATIONAL in the same way that you use a numeric-edited item that has USAGE DISPLAY.

You can also define a data item as numeric-edited by coding the BLANK WHEN ZERO clause for an elementary item that is defined as numeric by its PICTURE clause.

If you code a PICTURE clause but do not code a USAGE clause for data items that contain only one or more PICTURE symbols N, you can use the compiler option NSYMBOL(NATIONAL) to ensure that such items are treated as national data items instead of as DBCS items.

RELATED TASKS

“Displaying numeric data” on page 45

RELATED REFERENCES

“NSYMBOL” on page 340

BLANK WHEN ZERO clause (*Enterprise COBOL Language Reference*)

Using national literals

To specify national literals, use the prefix character N and compile with the option NSYMBOL(NATIONAL).

You can use either of these notations:

- `N"character-data"`
- `N'character-data'`

If you compile with the option NSYMBOL(DBCS), the literal prefix character N specifies a DBCS literal, not a national literal.

To specify a national literal as a hexadecimal value, use the prefix NX. You can use either of these notations:

- `NX"hexadecimal-digits"`
- `NX'hexadecimal-digits'`

Each of the following MOVE statements sets the national data item Y to the UTF-16 value of the characters 'AB':

```

01 Y pic NN usage national.
. . .
  Move NX"00410042" to Y
  Move N"AB"         to Y
  Move "AB"          to Y

```

Do not use alphanumeric hexadecimal literals in contexts that call for national literals, because such usage is easily misunderstood. For example, the following statement also results in moving the UTF-16 characters 'AB' (not the hexadecimal bit pattern C1C2) to Y, where Y is defined as USAGE NATIONAL:

```
Move X"C1C2" to Y
```

You cannot use national literals in the SPECIAL-NAMES paragraph or as program-names. You can use a national literal to name an object-oriented method in the METHOD-ID paragraph or to specify a method-name in an INVOKE statement.

RELATED TASKS

“Using literals” on page 25

RELATED REFERENCES

“NSYMBOL” on page 340

National literals (*Enterprise COBOL Language Reference*)

Using national-character figurative constants

You can use the figurative constant ALL *national-literal* in a context that requires national characters. ALL *national-literal* represents all or part of the string that is generated by successive concatenations of the encoding units that make up the national literal.

You can use the figurative constants QUOTE, SPACE, HIGH-VALUE, LOW-VALUE, or ZERO in a context that requires national characters, such as a MOVE statement, an implicit move, or a relation condition that has national operands. In these contexts, the figurative constant represents a national-character (UTF-16) value.

When you use the figurative constant HIGH-VALUE in a context that requires national characters, its value is NX'FFFF'. When you use LOW-VALUE in a context that requires national characters, its value is NX'0000'.

Restrictions: You must not use HIGH-VALUE or the value assigned from HIGH-VALUE in a way that results in conversion of the value from one data representation to another (for example, between USAGE DISPLAY and USAGE NATIONAL). X'FF' (the value of HIGH-VALUE in an alphanumeric context when the EBCDIC collating sequence is being used) does not represent a valid EBCDIC character, and NX'FFFF' does not represent a valid national character. Conversion of such a value to another representation results in a *substitution character* being used (not X'FF' or NX'FFFF'). Consider the following example:

```

01 natl-data PIC NN Usage National.
01 alph-data PIC XX.
. . .
  MOVE HIGH-VALUE TO natl-data, alph-data
  IF natl-data = alph-data. . .

```

The IF statement above evaluates as false even though each of its operands was set to HIGH-VALUE. Before an elementary alphanumeric operand is compared to a national operand, the alphanumeric operand is treated as though it were moved to a temporary national data item, and the alphanumeric characters are converted to

the corresponding national characters. When X'FF' is converted to UTF-16, however, the UTF-16 item gets a substitution character value and so does not compare equally to NX'FFFF'.

RELATED TASKS

“Converting to or from national (Unicode) representation” on page 137

“Comparing national (UTF-16) data” on page 147

RELATED REFERENCES

Figurative constants (*Enterprise COBOL Language Reference*)

DISPLAY-OF (*Enterprise COBOL Language Reference*)

Support for Unicode: Using Unicode Services

Defining national numeric data items

Define data items with the USAGE NATIONAL clause to hold numeric data that is represented in national characters (UTF-16). You can define national decimal items and national floating-point items.

To define a national decimal item, code a PICTURE clause that contains only the symbols 9, P, S, and V. If the PICTURE clause contains S, the SIGN IS SEPARATE clause must be in effect for that item.

To define a national floating-point item, code a PICTURE clause that defines a floating-point item (for example, +99999.9E-99).

You can use national decimal items in the same way that you use zoned decimal items. You can use national floating-point items in the same way that you use display floating-point items.

RELATED TASKS

“Defining numeric data” on page 43

“Displaying numeric data” on page 45

RELATED REFERENCES

SIGN clause (*Enterprise COBOL Language Reference*)

National groups

National groups, which are specified either explicitly or implicitly with the GROUP-USAGE NATIONAL clause, contain only data items that have USAGE NATIONAL. In most cases, a national group item is processed as though it were redefined as an elementary category national item described as PIC N(*m*), where *m* is the number of national (UTF-16) characters in the group.

For some operations on national groups, however (just as for some operations on alphanumeric groups), group semantics apply. Such operations (for example, MOVE CORRESPONDING and INITIALIZE) recognize or process the elementary items within the national group.

Where possible, use national groups instead of alphanumeric groups that contain USAGE NATIONAL items. National groups provide several advantages for the processing of national data compared to the processing of national data within alphanumeric groups:

- When you move a national group to a longer data item that has USAGE NATIONAL, the receiving item is padded with national characters. By contrast, if you move an alphanumeric group that contains national characters to a longer

alphanumeric group that contains national characters, alphanumeric spaces are used for padding. As a result, mishandling of data items could occur.

- When you move a national group to a shorter data item that has USAGE NATIONAL, the national group is truncated at national-character boundaries. By contrast, if you move an alphanumeric group that contains national characters to a shorter alphanumeric group that contains national characters, truncation might occur between the 2 bytes of a national character.
- When you move a national group to a national-edited or numeric-edited item, the content of the group is edited. By contrast, if you move an alphanumeric group to an edited item, no editing takes place.
- When you use a national group as an operand in a STRING, UNSTRING, or INSPECT statement:
 - The group content is processed as national characters rather than as single-byte characters.
 - TALLYING and POINTER operands operate at the logical level of national characters.
 - The national group operand is supported with a mixture of other national operand types.

By contrast, if you use an alphanumeric group that contains national characters in these contexts, the characters are processed byte by byte. As a result, invalid handling or corruption of data could occur.

USAGE NATIONAL groups: A group item can specify the USAGE NATIONAL clause at the group level as a convenient shorthand for the USAGE of each of the elementary data items within the group. Such a group is *not* a national group, however, but an alphanumeric group, and behaves in many operations, such as moves and compares, like an elementary data item of USAGE DISPLAY (except that no editing or conversion of data occurs).

RELATED TASKS

“Assigning values to group data items (MOVE)” on page 33

“Joining data items (STRING)” on page 105

“Splitting data items (UNSTRING)” on page 107

“Tallying and replacing data items (INSPECT)” on page 115

“Using national groups”

RELATED REFERENCES

GROUP-USAGE clause (*Enterprise COBOL Language Reference*)

Using national groups

To define a group data item as a national group, code a GROUP-USAGE NATIONAL clause at the group level for the item. The group can contain only data items that explicitly or implicitly have USAGE NATIONAL.

The following data description entry specifies that a level-01 group and its subordinate groups are national group items:

```
01 Nat-Group-1    GROUP-USAGE NATIONAL.
   02 Group-1.
      04 Month     PIC 99.
      04 DayOf     PIC 99.
      04 Year      PIC 9999.
   02 Group-2    GROUP-USAGE NATIONAL.
      04 Amount   PIC 9(4).99 USAGE NATIONAL.
```

In the example above, Nat-Group-1 is a national group, and its subordinate groups Group-1 and Group-2 are also national groups. A GROUP-USAGE NATIONAL clause is implied for Group-1, and USAGE NATIONAL is implied for the subordinate items in Group-1. Month, DayOf, and Year are national decimal items, and Amount is a numeric-edited item that has USAGE NATIONAL.

You can subordinate national groups within alphanumeric groups as in the following example:

```
01 Alpha-Group-1.
   02 Group-1.
       04 Month    PIC 99.
       04 DayOf    PIC 99.
       04 Year      PIC 9999.
   02 Group-2    GROUP-USAGE NATIONAL.
       04 Amount  PIC 9(4).99.
```

In the example above, Alpha-Group-1 and Group-1 are alphanumeric groups; USAGE DISPLAY is implied for the subordinate items in Group-1. (If Alpha-Group-1 specified USAGE NATIONAL at the group level, USAGE NATIONAL would be implied for each of the subordinate items in Group-1. However, Alpha-Group-1 and Group-1 would be alphanumeric groups, not national groups, and would behave like alphanumeric groups during operations such as moves and compares.) Group-2 is a national group, and USAGE NATIONAL is implied for the numeric-edited item Amount.

You cannot subordinate alphanumeric groups within national groups. All elementary items within a national group must be explicitly or implicitly described as USAGE NATIONAL, and all group items within a national group must be explicitly or implicitly described as GROUP-USAGE NATIONAL.

RELATED CONCEPTS

“National groups” on page 133

RELATED TASKS

“Using national groups as elementary items”

“Using national groups as group items” on page 136

RELATED REFERENCES

GROUP-USAGE clause (*Enterprise COBOL Language Reference*)

Using national groups as elementary items

In most cases, you can use a national group as though it were an elementary data item.

In the following example, a national group item, Group-1, is moved to a national-edited item, Edited-date. Because Group-1 is treated as an elementary data item during the move, editing takes place in the receiving data item. The value in Edited-date after the move is 06/23/2010 in national characters.

```
01 Edited-date  PIC NN/NN/NNNN  USAGE NATIONAL.
01 Group-1     GROUP-USAGE NATIONAL.
   02 Month     PIC 99    VALUE 06.
   02 DayOf     PIC 99    VALUE 23.
   02 Year       PIC 9999  VALUE 2010.
   . . .
   MOVE Group-1 to Edited-date.
```

If Group-1 were instead an alphanumeric group in which each of its subordinate items had USAGE NATIONAL (specified either explicitly with a USAGE NATIONAL clause on each elementary item, or implicitly with a USAGE NATIONAL clause at the group

level), a group move, rather than an elementary move, would occur. Neither editing nor conversion would take place during the move. The value in the first eight character positions of Edited-date after the move would be 06232010 in national characters, and the value in the remaining two character positions would be 4 bytes of alphanumeric spaces.

RELATED TASKS

- “Assigning values to group data items (MOVE)” on page 33
- “Comparing national data and alphanumeric-group operands” on page 149
- “Using national groups as group items”

RELATED REFERENCES

MOVE statement (*Enterprise COBOL Language Reference*)

Using national groups as group items

In some cases when you use a national group, it is handled with group semantics; that is, the elementary items in the group are recognized or processed.

In the following example, an INITIALIZE statement that acts upon national group item Group-OneN causes the value 15 in national characters to be moved to only the numeric items in the group:

```
01 Group-OneN    Group-Usage National.
   05 Trans-codeN  Pic N   Value "A".
   05 Part-numberN Pic NN  Value "XX".
   05 Trans-quantN Pic 99  Value 10.
   . . .
   Initialize Group-OneN Replacing Numeric Data By 15
```

Because only Trans-quantN in Group-OneN above is numeric, only Trans-quantN receives the value 15. The other subordinate items are unchanged.

The table below summarizes the cases where national groups are processed with group semantics.

Table 17. National group items that are processed with group semantics

Language feature	Uses of national group items	Comment
CORRESPONDING phrase of the ADD, SUBTRACT, or MOVE statement	Specify a national group item for processing as a group in accordance with the rules of the CORRESPONDING phrase.	Elementary items within the national group are processed like elementary items that have USAGE NATIONAL within an alphanumeric group.
Host variable in EXEC SQL statement	Specify a national group item as a host variable.	The national group item is in effect shorthand for the set of host variables that are subordinate to the group item.
INITIALIZE statement	Specify a national group for processing as a group in accordance with the rules of the INITIALIZE statement.	Elementary items within the national group are initialized like elementary items that have USAGE NATIONAL within an alphanumeric group.
Name qualification	Use the name of a national group item to qualify the names of elementary data items and of subordinate group items in the national group.	Follow the same rules for qualification as for an alphanumeric group.

Table 17. National group items that are processed with group semantics (continued)

Language feature	Uses of national group items	Comment
THROUGH phrase of the RENAME clause	To specify a national group item in the THROUGH phrase, use the same rules as for an alphanumeric group item.	The result is an alphanumeric group item.
FROM phrase of the XML GENERATE statement	Specify a national group item in the FROM phrase for processing as a group in accordance with the rules of the XML GENERATE statement.	Elementary items within the national group are processed like elementary items that have USAGE NATIONAL within an alphanumeric group.

RELATED TASKS

- “Initializing a structure (INITIALIZE)” on page 30
- “Initializing a table (INITIALIZE)” on page 73
- “Assigning values to elementary data items (MOVE)” on page 32
- “Assigning values to group data items (MOVE)” on page 33
- “Finding the length of data items” on page 122
- “Generating XML output” on page 571
- “Using national group items in SQL statements” on page 444

RELATED REFERENCES

- Qualification (*Enterprise COBOL Language Reference*)
- RENAME clause (*Enterprise COBOL Language Reference*)

Storage of character data

Use the table below to compare alphanumeric (DISPLAY), DBCS (DISPLAY-1), and Unicode (NATIONAL) encoding and to plan storage usage.

Table 18. Encoding and size of alphanumeric, DBCS, and national data

Characteristic	DISPLAY	DISPLAY-1	NATIONAL
Character encoding unit	1 byte	2 bytes	2 bytes
Code page	EBCDIC	EBCDIC DBCS	UTF-16BE ¹
Encoding units per graphic character	1	1	1 or 2 ²
Bytes per graphic character	1 byte	2 bytes	2 or 4 bytes
<ol style="list-style-type: none"> 1. Use the CODEPAGE compiler option to specify the EBCDIC code page that is applicable to alphanumeric or DBCS data. 2. Most characters are represented in UTF-16 using one encoding unit. In particular, the following characters are represented using a single UTF-16 encoding unit per character: <ul style="list-style-type: none"> • COBOL characters A-Z, a-z, 0-9, space, + - * / = \$, ; . " () > < : • All characters that are converted from an EBCDIC or ASCII code page 			

RELATED CONCEPTS

- “Unicode and the encoding of language characters” on page 129

Converting to or from national (Unicode) representation

You can implicitly or explicitly convert data items to national (UTF-16) representation.

You can implicitly convert alphabetic, alphanumeric, DBCS, or integer data to national data by using the MOVE statement. Implicit conversions also take place in other COBOL statements, such as IF statements that compare an alphanumeric data item with a data item that has USAGE NATIONAL.

You can explicitly convert to and from national data items by using the intrinsic functions NATIONAL-OF and DISPLAY-OF, respectively. By using these intrinsic functions, you can specify a code page for the conversion that is different from the code page that is in effect with the CODEPAGE compiler option.

RELATED TASKS

“Converting alphanumeric, DBCS, and integer to national (MOVE)”

“Converting alphanumeric or DBCS to national (NATIONAL-OF)” on page 139

“Converting national to alphanumeric (DISPLAY-OF)” on page 139

“Overriding the default code page” on page 140

“Comparing national (UTF-16) data” on page 147

RELATED REFERENCES

“CODEPAGE” on page 313

“Conversion exceptions” on page 140

Converting alphanumeric, DBCS, and integer to national (MOVE)

You can use a MOVE statement to implicitly convert data to national representation.

You can move the following kinds of data to category national or national-edited data items, and thus convert the data to national representation:

- Alphabetic
- Alphanumeric
- Alphanumeric-edited
- DBCS
- Integer of USAGE DISPLAY
- Numeric-edited of USAGE DISPLAY

You can likewise move the following kinds of data to numeric-edited data items that have USAGE NATIONAL:

- Alphanumeric
- Display floating-point (floating-point of USAGE DISPLAY)
- Numeric-edited of USAGE DISPLAY
- Integer of USAGE DISPLAY

For complete rules about moves to national data, see the related reference about the MOVE statement.

For example, the MOVE statement below moves the alphanumeric literal "AB" to the national data item UTF16-Data:

```
01 UTF16-Data Pic N(2) Usage National.  
   . . .  
   Move "AB" to UTF16-Data
```

After the MOVE statement above, UTF16-Data contains NX'00410042', the national representation of the alphanumeric characters 'AB'.

If padding is required in a receiving data item that has USAGE NATIONAL, the default UTF-16 space character (NX'0020') is used. If truncation is required, it occurs at the boundary of a national-character position.

RELATED TASKS

“Assigning values to elementary data items (MOVE)” on page 32

“Assigning values to group data items (MOVE)” on page 33

“Displaying numeric data” on page 45

“Coding for use of DBCS support” on page 150

RELATED REFERENCES

MOVE statement (*Enterprise COBOL Language Reference*)

Converting alphanumeric or DBCS to national (NATIONAL-OF)

Use the NATIONAL-OF intrinsic function to convert alphabetic, alphanumeric, or DBCS data to a national data item. Specify the source code page as the second argument if the source is encoded in a different code page than is in effect with the CODEPAGE compiler option.

“Example: converting to and from national data” on page 140

RELATED TASKS

“Processing UTF-8 data” on page 141

“Processing Chinese GB 18030 data” on page 146

“Processing alphanumeric data items that contain DBCS data” on page 152

RELATED REFERENCES

“CODEPAGE” on page 313

NATIONAL-OF (*Enterprise COBOL Language Reference*)

Converting national to alphanumeric (DISPLAY-OF)

Use the DISPLAY-OF intrinsic function to convert national data to an alphanumeric (USAGE DISPLAY) character string that is represented in a code page that you specify as the second argument.

If you omit the second argument, the output code page is the one that was in effect with the CODEPAGE compiler option when the source was compiled.

If you specify an EBCDIC or ASCII code page that combines single-byte character set (SBCS) and DBCS characters, the returned string might contain a mixture of SBCS and DBCS characters. The DBCS substrings are delimited by shift-in and shift-out characters if the code page in effect for the function is an EBCDIC code page.

“Example: converting to and from national data” on page 140

RELATED TASKS

“Processing UTF-8 data” on page 141

“Processing Chinese GB 18030 data” on page 146

RELATED REFERENCES

DISPLAY-OF (*Enterprise COBOL Language Reference*)

Overriding the default code page

In some cases, you might need to convert data to or from a code page that differs from the CCSID that is specified as the CODEPAGE option value. To do so, convert the item by using a conversion function in which you explicitly specify the code page.

If you specify a code page as an argument to the DISPLAY-OF intrinsic function, and the code page differs from the code page that is in effect with the CODEPAGE compiler option, do not use the function result in any operations that involve implicit conversion (such as an assignment to, or comparison with, a national data item). Such operations assume the EBCDIC code page that is specified with the CODEPAGE compiler option.

RELATED REFERENCES

"CODEPAGE" on page 313

Conversion exceptions

Implicit or explicit conversion between national data and alphanumeric data can fail and generate a severity-3 Language Environment condition.

Failure can occur if the code page that you specified implicitly or explicitly is not a valid code page.

A character that does not have a counterpart in the target CCSID does not result in a conversion exception. Such a character is converted to a *substitution character* in the target code page.

RELATED REFERENCES

"CODEPAGE" on page 313

Example: converting to and from national data

The following example shows the NATIONAL-OF and DISPLAY-OF intrinsic functions and the MOVE statement for converting to and from national (UTF-16) data items. It also demonstrates the need for explicit conversions when you operate on strings that are encoded in multiple code pages.

```
CBL CODEPAGE(00037)
* . . .
01 Data-in-Unicode          pic N(100) usage national.
01 Data-in-Greek           pic X(100).
01 other-data-in-US-English pic X(12) value "PRICE in $ =".
* . . .
    Read Greek-file into Data-in-Greek
    Move function National-of(Data-in-Greek, 00875)
      to Data-in-Unicode
* . . . process Data-in-Unicode here . . .
    Move function Display-of(Data-in-Unicode, 00875)
      to Data-in-Greek
    Write Greek-record from Data-in-Greek
```

The example above works correctly because the input code page is specified. Data-in-Greek is converted as data represented in CCSID 00875 (Greek). However, the following statement results in an incorrect conversion unless all the characters in the item happen to be among those that have a common representation in both the Greek and the English code pages:

```
Move Data-in-Greek to Data-in-Unicode
```

The MOVE statement above converts Data-in-Greek to Unicode representation based on the CCSID 00037 (U.S. English) to UTF-16 conversion. This conversion does not produce the expected results because Data-in-Greek is encoded in CCSID 00875.

If you can correctly set the CODEPAGE compiler option to CCSID 00875 (that is, the rest of your program also handles EBCDIC data in Greek), you can code the same example correctly as follows:

```
CBL CODEPAGE(00875)
* . . .
01 Data-in-Unicode pic N(100) usage national.
01 Data-in-Greek   pic X(100).
* . . .
    Read Greek-file into Data-in-Greek
* . . . process Data-in-Greek here ...
* . . . or do the following (if need to process data in Unicode):
    Move Data-in-Greek to Data-in-Unicode
* . . . process Data-in-Unicode
    Move function Display-of(Data-in-Unicode) to Data-in-Greek
    Write Greek-record from Data-in-Greek
```

Processing UTF-8 data

To process UTF-8 data, first convert the UTF-8 data to UTF-16 in a national data item. After processing the national data, convert it back to UTF-8 for output. For the conversions, use the intrinsic functions NATIONAL-OF and DISPLAY-OF, respectively. Use code page 1208 for UTF-8 data.

National data is encoded in UTF-16, which uses one encoding unit for almost all commonly encountered characters. With this property, you can use string operations such as reference modification on the national data. If it is more convenient to retain the UTF-8 encoding, use the Unicode intrinsic functions to assist with processing the data. For details, see “Using intrinsic functions to process UTF-8 encoded data” on page 142.

Take the following steps to convert ASCII or EBCDIC data to UTF-8:

1. Use the function NATIONAL-OF to convert the ASCII or EBCDIC string to a national (UTF-16) string.
2. Use the function DISPLAY-OF to convert the national string to UTF-8.

The following example converts Greek EBCDIC data to UTF-8:

```
01 Greek-EBCDIC pic X(10) value "αβγδεζηθ".
01 UnicodeString pic N(10).
01 UTF-8-String pic X(20).
    Move function National-of(Greek-EBCDIC, 00875) to UnicodeString
    Move function Display-of(UnicodeString, 01208) to UTF-8-String
```

Usage note: Use care if you use reference modification to refer to data encoded in UTF-8. UTF-8 characters are encoded with a varying number of bytes per character. Avoid operations that might split a multibyte character.

RELATED TASKS

“Referring to substrings of data items” on page 111

“Converting to or from national (Unicode) representation” on page 137

“Parsing XML documents encoded in UTF-8” on page 551

“Using intrinsic functions to process UTF-8 encoded data” on page 142

Using intrinsic functions to process UTF-8 encoded data

If it is more convenient to keep your data encoded in UTF-8, use the Unicode intrinsic functions to facilitate testing and processing the UTF-8 data.

You can use the following intrinsic functions:

UVALID To verify that the UTF-8 character data is well-formed

USUPPLEMENTARY

If the data is to be converted to national, and it is important that every character can be represented by a single 16-bit encoding unit, use the USUPPLEMENTARY function to determine whether a valid UTF-8 character string contains a Unicode supplementary code point; that is, a code point with a Unicode scalar value above U+FFFF, requiring a 4-byte representation in UTF-8.

USUBSTR

It provides a convenient alternative to reference modification for referring to substrings of the UTF-8 character string. USUBSTR expects character position and length arguments versus the computed byte locations and counts required by reference modification.

Auxiliary functions can provide additional information about a valid UTF-8 character string:

ULENGTH

To determine the total number of Unicode code points in the string

UPOS To determine the byte position in the string of the *n*th Unicode code point

UWIDTH To determine the width in bytes of the *n*th Unicode code point in the string

The following code fragment illustrates UTF-8 validity checking, and the use of the auxiliary functions:

```
checkUTF-8-validity.  
  Compute u = function UVALID(UTF-8-testStr)  
  If u not = 0  
    Display 'checkUTF-8-validity failure:'  
    Display ' The UTF-8 representation is not valid,'  
      'starting at byte ' u '.'  
  Compute v = function ULENGTH(UTF-8-testStr(1:u - 1))  
  Compute u = function UPOS(UTF-8-testStr v)  
  Compute w = function UWIDTH(UTF-8-testStr v)  
  Display ' The ' v 'th and last valid code point starts '  
    'at byte ' u ' for ' w ' bytes.'  
End-if.
```

In the following string, the sequence that starts with x'F5' is not valid UTF-8 because no byte can have a value in the range x'F5' to x'FF':

```
x'6162D0B0E4BA8CF5646364'
```

The output from checkUTF-8-validity for this string is as follows:

```
checkUTF-8-validity failure:  
The UTF-8 representation is not valid, starting at byte 08.  
The 04th and last valid code point starts at byte 05 for 03 bytes.
```

The following code fragment illustrates checking for the presence of a Unicode supplementary code point, requiring a 4-byte representation in UTF-8:

```

checkUTF-8-suppl.
  Compute u = function USUPPLEMENTARY(UTF-8-testStr)
  If u not = 0
    Display ' checkUTF-8-suppl hit:'
    Compute v = function ULENGTH(UTF-8-testStr(1:u - 1))
    Compute w = function UWIDTH(UTF-8-testStr v + 1)
    Display ' The ' v 'th code point of the string'
      ', starting at byte ' u ', '
    Display ' is a Unicode supplementary code point, '
      'width ' w ' bytes.'
  End-if.

```

In the following string, the sequence x'F0908C82' is a supplementary character (as is any valid UTF-8 sequence beginning with a byte in the range x'F0' to x'F4'):

```
x'6162D0B0E4BA8CF0908C826364'
```

The output from checkUTF-8-suppl for this string is as follows:

```

checkUTF-8-suppl hit:
  The 04th code point of the string, starting at byte 08,
  is a Unicode supplementary code point, width 04 bytes.

```

RELATED REFERENCES

“CODEPAGE” on page 313

Example: deriving initials from UTF-8 names

The following program uses the Unicode functions to derive composers’ initials from a table of names in Czech. It is intended to illustrate these functions, and is not necessarily the most efficient way of doing the task. Although the program processes the composer names in UTF-8, the data begins and ends in EBCDIC in order to permit a meaningful display of the program source and output. The compiler option CODEPAGE(1153) ensures that the names are interpreted correctly when translated to and from Unicode.

Program initials

```
Program initials
Process cp(880)
Identification division.
  Program-id. initials.
Data division.
Working-storage section.
1 utilityVariables.
  2 UTF-8-space pic x value x'20'.
  2 UTF-8-hyphen pic x value x'2d'.
  2 UTF-8-ch pic xxx.
  2 UTF-8-testStr pic x(65).
  2 i comp pic 9.
  2 j comp pic 99.
  2 u comp pic 99.
  2 v comp pic 99.
  2 w comp pic 99.
  2 hex pic x(160).
1 EBCDICnameData.
  2 pic x(50) *> Aleksandr Porfirevic Borodin
    value 'Александр Порфирьевич Бородин'.
  2 pic x(50) *> Sergei Sergeevich Prokofiev
    value 'Сергей Сергеевич Прокофьев'.
  2 pic x(50) *> Nikolai Andreyevich Rimsky-Korsakov
    value 'Николай Андреевич Римский-Корсаков'.
  2 pic x(50) *> Sergei Vasilievich Rachmaninoff
    value 'Сергей Васильевич Рахманинов'.
  2 pic x(50) *> Pyotr Ilyich Tchaikovsky
    value 'Пётр Ильич Чайковский'.
1 redefines EBCDICnameData.
  2 EBCDICname pic x(50) occurs 5 times.
1 UTF-8-nameData.
  2 composer pic x(65) occurs 5 times.
1 composerInitials.
  2 occurs 5.
  3 cInitSize comp pic 99.
  3 cInit pic x(12).
1 state pic 9.
  88 seekingInitial value 0.
  88 seekingSeparator value 1.
Procedure division.
main.
  Display 'Test check functions:'
  Move 0 to i
  Move x'6162D0B0E4BA8CFFFF646364' to UTF-8-testStr
  Perform checkUTF-8-validity
  If u = 0
    Display 'Validity check failure.'
    Stop run
  End-if
  Move x'6162D0B0E4BA8CF0908C826364' to UTF-8-testStr
  Perform checkUTF-8-supp
  If u = 0
    Display 'Supplementary character check failure.'
    Stop run
  End-if
  Display ' '
  Display 'Compute composer initials:'
  Initialize composerInitials
  Perform varying i from 1 by 1 until i > 5
  Move function display-of(
    function national-of(EBCDICname(i)) 1208) to
```

Program initials, continued

```
        composer(i)
Move composer(i) to UTF-8-testStr
Perform checkUTF-8-validity
If u not = 0
    Stop run
End-if
Perform checkUTF-8-supp
If u not = 0
    Stop run
End-if
Set seekingInitial to true
Move 1 to cInitSize(i)
Perform varying j from 1 by 1
    until j > function ULENGTH(composer(i))
Move function USUBSTR(composer(i) j 1) to UTF-8-ch
If seekingInitial and
    UTF-8-ch not = UTF-8-Space and UTF-8-Hyphen
String function USUBSTR(composer(i) j 1)
    delimited by size
    into cInit(i) with pointer cInitSize(i)
Set seekingSeparator to true
End-if
If seekingSeparator and
    (UTF-8-ch = UTF-8-Space or UTF-8-Hyphen)
Set seekingInitial to true
End-if
End-perform
Subtract 1 from cInitSize(i)
End-perform
Perform varying i from 1 by 1 until i > 5
Call 'tohex' using hex cInit(i) value cInitSize(i)
Display ' #' i ': ' function display-of(
    function national-of(cInit(i) (1:cInitSize(i)) 1208))
    ' (x''' hex(1:2 * cInitSize(i)) ''')'
End-perform.
Goback.
checkUTF-8-validity.
Compute u = function UVALID(UTF-8-testStr)
If u not = 0
    Display ' checkUTF-8-validity failure:'
    Display ' UTF-8 representation of composer name #' i
        ' is not valid,'
    Display ' starting at byte ' u '.'
    Compute v = function ULENGTH(UTF-8-testStr(1:u - 1))
    Compute u = function UPOS(UTF-8-testStr v)
    Compute W = function UWIDTH(UTF-8-testStr v)
    Display ' The ' v 'th and last valid character starts '
        'at byte ' u ' for ' w ' bytes.'
End-if.
checkUTF-8-supp.
Compute u = function USUPPLEMENTARY(UTF-8-testStr)
If u not = 0
    Display ' checkUTF-8-supp failure:'
    Compute v = function ULENGTH(UTF-8-testStr(1:u - 1))
    Compute w = function UWIDTH(UTF-8-testStr v + 1)
    Display ' The ' v 'th character of composer name #' i
        ', starting at byte ' u ','
    Display ' is a Unicode supplementary character, '
        'width ' w ' bytes.'
End-if.
End program initials.
```

Output from program initials

```
Compute composer initials...
#1: ALD (x'414C44')
#2: LJ (x'4C4A')
#3: RJK (x'524A4B')
#4: PK (x'504B')
#5: JVHV (x'4A564856')
```

Program toHex

```
Identification division.
  Program-id. toHex.
Data division.
  Working-storage section.
  1 hexv.
    2 pic x(32) value '000102030405060708090A0B0C0D0E0F'.
    2 pic x(32) value '101112131415161718191A1B1C1D1E1F'.
    2 pic x(32) value '202122232425262728292A2B2C2D2E2F'.
    2 pic x(32) value '303132333435363738393A3B3C3D3E3F'.
    2 pic x(32) value '404142434445464748494A4B4C4D4E4F'.
    2 pic x(32) value '505152535455565758595A5B5C5D5E5F'.
    2 pic x(32) value '606162636465666768696A6B6C6D6E6F'.
    2 pic x(32) value '707172737475767778797A7B7C7D7E7F'.
    2 pic x(32) value '808182838485868788898A8B8C8D8E8F'.
    2 pic x(32) value '909192939495969798999A9B9C9D9E9F'.
    2 pic x(32) value 'A0A1A2A3A4A5A6A7A8A9AAABACADAEAF'.
    2 pic x(32) value 'B0B1B2B3B4B5B6B7B8B9BABBBCBDBEBF'.
    2 pic x(32) value 'C0C1C2C3C4C5C6C7C8C9CACBCCCDCECF'.
    2 pic x(32) value 'D0D1D2D3D4D5D6D7D8D9DADBDCDDDEDF'.
    2 pic x(32) value 'E0E1E2E3E4E5E6E7E8E9EAEBECEDEEEF'.
    2 pic x(32) value 'F0F1F2F3F4F5F6F7F8F9FAFBFCFDFEFF'.
  1 redefines hexv.
  2 hex pic xx occurs 256 times.
Local-storage section.
  1 i pic 9(4) binary.
  1 j pic 9(4) binary value 0.
  1 jx redefines j.
  2 pic x.
  2 jxd pic x.
Linkage section.
  1 ostr.
  2 ostrv pic xx occurs 1024 times.
  1 istr.
  2 istrv pic x occurs 1024 times.
  1 len pic 9(9) binary.
Procedure division using ostr istr value len.
  If len > 1024
    Display '>> Error: length ' len ' greater than toHex '
      'supported maximum of 1024.'
    Stop run
  End-if
  Perform with test before varying i from 1 by 1 until i > len
    Move 0 to j
    Move istrv(i) to jxd
    Add 1 to j
    Move hex(j) to ostrv(i)
  End-perform
  Goback
  .
End program toHex.
```

Processing Chinese GB 18030 data

GB 18030 is a national-character standard specified by the government of the People's Republic of China.

GB 18030 characters can be encoded in either UTF-16 or in code page CCSID 1392. Code page 1392 is an ASCII multibyte code page that uses 1, 2, or 4 bytes per character. A subset of the GB 18030 characters can be encoded in the Chinese ASCII code page, CCSID 1386, or in the Chinese EBCDIC code page, CCSID 1388.

Enterprise COBOL does not have explicit support for GB 18030, but does support the processing of GB 18030 characters in several ways. You can:

- Use DBCS data items to process GB 18030 characters that are represented in CCSID 1388.
- Use national data items to define and process GB 18030 characters that are represented in UTF-16, CCSID 01200.
- Process data in any code page (including CCSID 1388 or 1392) by converting the data to UTF-16, processing the UTF-16 data, and then converting the data back to the original code-page representation.

When you need to process Chinese GB 18030 data that requires conversion, first convert the input data to UTF-16 in a national data item. After you process the national data item, convert it back to Chinese GB 18030 for output. For the conversions, use the intrinsic functions NATIONAL-OF and DISPLAY-OF, respectively, and specify code page 1388 or 1392 as the second argument of each function.

The following example illustrates these conversions:

```
01 Chinese-EBCDIC pic X(16) value "奥林匹克运动会".
01 Chinese-GB18030-String pic X(16).
01 UnicodeString pic N(14).
. . .
    Move function National-of(Chinese-EBCDIC, 1388) to UnicodeString
* Process data in Unicode
    Move function Display-of(UnicodeString, 1388) to Chinese-GB18030-String
```

RELATED TASKS

“Converting to or from national (Unicode) representation” on page 137
 “Coding for use of DBCS support” on page 150

RELATED REFERENCES

“Storage of character data” on page 137

Comparing national (UTF-16) data

You can compare national (UTF-16) data, that is, national literals and data items that have USAGE NATIONAL (whether of class national or class numeric), explicitly or implicitly with other kinds of data in relation conditions.

You can code conditional expressions that use national data in the following statements:

- EVALUATE
- IF
- INSPECT
- PERFORM
- SEARCH
- STRING
- UNSTRING

For full details about comparing national data items to other data items, see the related references.

RELATED TASKS

“Comparing two class national operands” on page 148
 “Comparing class national and class numeric operands” on page 148
 “Comparing national numeric and other numeric operands” on page 149

“Comparing national and other character-string operands” on page 149
“Comparing national data and alphanumeric-group operands” on page 149

RELATED REFERENCES

Relation conditions (*Enterprise COBOL Language Reference*)
General relation conditions (*Enterprise COBOL Language Reference*)
National comparisons (*Enterprise COBOL Language Reference*)
Group comparisons (*Enterprise COBOL Language Reference*)

Comparing two class national operands

You can compare the character values of two operands of class national.

Either operand (or both) can be any of the following types of items:

- A national group
- An elementary category national or national-edited data item
- A numeric-edited data item that has USAGE NATIONAL

One of the operands can instead be a national literal or a national intrinsic function.

When you compare two class national operands that have the same length, they are determined to be equal if all pairs of the corresponding characters are equal. Otherwise, comparison of the binary values of the first pair of unequal characters determines the operand with the larger binary value.

When you compare operands that have unequal lengths, the shorter operand is treated as if it were padded on the right with default UTF-16 space characters (NX'0020') to the length of the longer operand.

The PROGRAM COLLATING SEQUENCE clause does not affect the comparison of two class national operands.

RELATED CONCEPTS

“National groups” on page 133

RELATED TASKS

“Using national groups” on page 134

RELATED REFERENCES

National comparisons (*Enterprise COBOL Language Reference*)

Comparing class national and class numeric operands

You can compare national literals or class national data items to integer literals or numeric data items that are defined as integer (that is, national decimal items or zoned decimal items). At most one of the operands can be a literal.

You can also compare national literals or class national data items to floating-point data items (that is, display floating-point or national floating-point items).

Numeric operands are converted to national (UTF-16) representation if they are not already in national representation. A comparison is made of the national character values of the operands.

RELATED REFERENCES

General relation conditions (*Enterprise COBOL Language Reference*)

Comparing national numeric and other numeric operands

National numeric operands (national decimal and national floating-point operands) are data items of class numeric that have USAGE NATIONAL.

You can compare the algebraic values of numeric operands regardless of their USAGE. Thus you can compare a national decimal item or a national floating-point item with a binary item, an internal-decimal item, a zoned decimal item, a display floating-point item, or any other numeric item.

RELATED TASKS

"Defining national numeric data items" on page 133

RELATED REFERENCES

General relation conditions (*Enterprise COBOL Language Reference*)

Comparing national and other character-string operands

You can compare the character value of a national literal or class national data item with the character value of any of the following other character-string operands: alphabetic, alphanumeric, alphanumeric-edited, DBCS, or numeric-edited of USAGE DISPLAY.

These operands are treated as if they were moved to an elementary national data item. The characters are converted to national (UTF-16) representation, and the comparison proceeds with two national character operands.

RELATED TASKS

"Using national-character figurative constants" on page 132

RELATED REFERENCES

National comparisons (*Enterprise COBOL Language Reference*)

Comparing national data and alphanumeric-group operands

You can compare a national literal, a national group item, or any elementary data item that has USAGE NATIONAL to an alphanumeric group.

Neither operand is converted. The national operand is treated as if it were moved to an alphanumeric group item of the same size in bytes as the national operand, and the two groups are compared. An alphanumeric comparison is done regardless of the representation of the subordinate items in the alphanumeric group operand.

For example, Group-XN is an alphanumeric group that consists of two subordinate items that have USAGE NATIONAL:

```
01 Group-XN.  
   02 TransCode PIC NN   Value "AB"  Usage National.  
   02 Quantity  PIC 999  Value 123   Usage National.  
   .  
   .  
   .  
   If N"AB123" = Group-XN Then Display "EQUAL"  
   Else Display "NOT EQUAL".
```

When the IF statement above is executed, the 10 bytes of the national literal N"AB123" are compared byte by byte to the content of Group-XN. The items compare equally, and "EQUAL" is displayed.

Coding for use of DBCS support

IBM Enterprise COBOL for z/OS supports using applications in any of many national languages, including languages that use double-byte character sets (DBCS).

The following list summarizes the support for DBCS:

- DBCS characters in user-defined words (DBCS names)
- DBCS characters in comments
- DBCS data items (defined with PICTURE N, G, or G and B)
- DBCS literals
- DBCS compiler option

RELATED TASKS

“Defining DBCS data”

“Using DBCS literals”

“Testing for valid DBCS characters” on page 151

“Processing alphanumeric data items that contain DBCS data” on page 152

Appendix B, “Converting double-byte character set (DBCS) data,” on page 695

RELATED REFERENCES

“DBCS” on page 319

Defining DBCS data

Use the PICTURE and USAGE clauses to define DBCS data items. DBCS data items can use PICTURE symbols G, G and B, or N. Each DBCS character position is 2 bytes in length.

You can specify a DBCS data item by using the USAGE DISPLAY-1 clause. When you use PICTURE symbol G, you must specify USAGE DISPLAY-1. When you use PICTURE symbol N but omit the USAGE clause, USAGE DISPLAY-1 or USAGE NATIONAL is implied depending on the setting of the NSYMBOL compiler option.

If you use a VALUE clause with the USAGE clause in the definition of a DBCS item, you must specify a DBCS literal or the figurative constant SPACE or SPACES.

For the purpose of handling reference modifications, each character in a DBCS data item is considered to occupy the number of bytes that corresponds to the code-page width (that is, 2).

RELATED REFERENCES

“NSYMBOL” on page 340

Using DBCS literals

You can use the prefix N or G to represent a DBCS literal.

That is, you can specify a DBCS literal in either of these ways:

- N' *dbcs characters* ' (provided that the compiler option NSYMBOL(DBCS) is in effect)
- G' *dbcs characters* '

You can use quotation marks (") or single quotation marks (') as the delimiters of a DBCS literal irrespective of the setting of the APOST or QUOTE compiler option. You must code the same opening and closing delimiter for a DBCS literal.

The shift-out (SO) control character X'0E' must immediately follow the opening delimiter, and the shift-in (SI) control character X'0F' must immediately precede the closing delimiter.

In addition to DBCS literals, you can use alphanumeric literals to specify any character in one of the supported code pages. However, any string of DBCS characters that is within an alphanumeric literal must be delimited by the SO and SI characters, and the DBCS compiler option must be in effect for the SO and SI characters to be recognized as shift codes.

You cannot continue an alphanumeric literal that contains DBCS characters. The length of a DBCS literal is likewise limited by the available space in Area B on a single source line. The maximum length of a DBCS literal is thus 28 double-byte characters.

An alphanumeric literal that contains DBCS characters is processed byte by byte, that is, with semantics appropriate for single-byte characters, except when it is converted explicitly or implicitly to national data representation, as for example in an assignment to or comparison with a national data item.

RELATED TASKS

"Using figurative constants" on page 26

RELATED REFERENCES

"DBCS" on page 319

"NSYMBOL" on page 340

"QUOTE/APOST" on page 352

DBCS literals (*Enterprise COBOL Language Reference*)

Testing for valid DBCS characters

The Kanji class test tests for valid Japanese graphic characters. This testing includes Katakana, Hiragana, Roman, and Kanji character sets.

The Kanji class test is done by checking characters for the range X'41' through X'7E' in the first byte and X'41' through X'FE' in the second byte, plus the space character X'4040'.

The DBCS class test tests for valid graphic characters for the code page.

The DBCS class test is done by checking characters for the range X'41' through X'FE' in both the first and second byte of each character, plus the space character X'4040'.

RELATED TASKS

"Coding conditional expressions" on page 98

RELATED REFERENCES

Class condition (*Enterprise COBOL Language Reference*)

Processing alphanumeric data items that contain DBCS data

If you use byte-oriented operations (for example, `STRING`, `UNSTRING`, or reference modification) on an alphanumeric data item that contains DBCS characters, results are unpredictable. You should instead convert the item to a national data item before you process it.

That is, do these steps:

1. Convert the item to UTF-16 in a national data item by using a `MOVE` statement or the `NATIONAL-OF` intrinsic function.
2. Process the national data item as needed.
3. Convert the result back to an alphanumeric data item by using the `DISPLAY-OF` intrinsic function.

RELATED TASKS

“Joining data items (`STRING`)” on page 105

“Splitting data items (`UNSTRING`)” on page 107

“Referring to substrings of data items” on page 111

“Converting to or from national (Unicode) representation” on page 137

Chapter 8. Processing files

Reading and writing data is an essential part of every program. Your program retrieves information, processes it as you request, and then produces the results.

The source of the information and the target for the results can be one or more of the following items:

- Another program
- Direct-access storage device
- Magnetic tape
- Printer
- Terminal
- Card reader or punch

The information as it exists on an external device is in a physical record or block, a collection of information that is handled as a unit by the system during input or output operations.

Your COBOL program does not directly handle physical records. It processes logical records. A logical record can correspond to a complete physical record, part of a physical record, or to parts or all of one or more physical records. Your COBOL program handles logical records exactly as you have defined them.

In COBOL, a collection of logical records is a file, a sequence of pieces of information that your program can process.

RELATED CONCEPTS

“File organization and input-output devices”

RELATED TASKS

“Choosing file organization and access mode” on page 155

“Allocating files” on page 157

“Checking for input or output errors” on page 158

File organization and input-output devices

Depending on the input-output devices, your file organization can be sequential, line sequential, indexed, or relative. Decide on the file types and devices to be used when you design your program.

You have the following choices of file organization:

Sequential file organization

The chronological order in which records are entered when a file is created establishes the arrangement of the records. Each record except the first has a unique predecessor record, and each record except the last has a unique successor record. Once established, these relationships do not change.

The access (record transmission) mode allowed for sequential files is sequential only.

Line-sequential file organization

Line-sequential files are sequential files that reside in the z/OS UNIX file system and that contain only characters as data. Each record ends with a newline character.

The only access (record transmission) mode allowed for line-sequential files is sequential.

Indexed file organization

Each record in the file contains a special field whose contents form the record key. The position of the key is the same in each record. The index component of the file establishes the logical arrangement of the file, an ordering by record key. The actual physical arrangement of the records in the file is not significant to your COBOL program.

An indexed file can also use alternate indexes in addition to the record key. These keys let you access the file using a different logical ordering of the records.

The access (record transmission) modes allowed for indexed files are sequential, random, or dynamic. When you read or write indexed files sequentially, the sequence is that of the key values.

Relative file organization

Records in the file are identified by their location relative to the beginning of the file. The first record in the file has a relative record number of 1, the tenth record has a relative record number of 10, and so on.

The access (record transmission) modes allowed for relative files are sequential, random, or dynamic. When relative files are read or written sequentially, the sequence is that of the relative record number.

With IBM Enterprise COBOL for z/OS, requests to the operating system for the storage and retrieval of records from input-output devices are handled by the two access methods QSAM and VSAM, and the z/OS UNIX file system.

The device type upon which you elect to store your data could affect the choices of file organization available to you. Direct-access storage devices provide greater flexibility in the file organization options. Sequential-only devices limit organization options but have other characteristics, such as the portability of tapes, that might be useful.

Sequential-only devices

Terminals, printers, card readers, and punches are called *unit-record devices* because they process one line at a time. Therefore, you must also process records one at a time sequentially in your program when it reads from or writes to unit-record devices.

On tape, records are ordered sequentially, so your program must process them sequentially. Use QSAM physical sequential files when processing tape files. The records on tape can be fixed length or variable length.

Direct-access storage devices

Direct-access storage devices hold many records. The record arrangement of files stored on these devices determines the ways that your program can process the data. When using direct-access devices, you have greater flexibility within your program, because you can use several types of file organization:

- Sequential (VSAM or QSAM)
- Line sequential (z/OS UNIX)

- Indexed (VSAM)
- Relative (VSAM)

RELATED TASKS

“Allocating files” on page 157
 Chapter 9, “Processing QSAM files,” on page 159
 Chapter 10, “Processing VSAM files,” on page 185
 Chapter 11, “Processing line-sequential files,” on page 213
 “Choosing file organization and access mode”

Choosing file organization and access mode

There are several guidelines you can use to determine which file organization and access mode to use in an application.

Consider the following guidelines when choosing file organization:

- If an application accesses records (whether fixed-length or variable-length) only sequentially and does not insert records between existing records, a QSAM or VSAM sequential file is the simplest type.
- If you are developing an application for z/OS UNIX file system that sequentially accesses records that contain only printable characters and certain control characters, line-sequential files work best.
- If an application requires both sequential and random access (whether records are fixed length or variable length), a VSAM indexed file is the most flexible type.
- If an application inserts and deletes records randomly, a relative file works well.

Consider the following guidelines when choosing access mode:

- If a large percentage of a file is referenced or updated in an application, sequential access is faster than random or dynamic access.
- If a small percentage of records is processed during each run of an application, use random or dynamic access.

Table 19. Summary of file organizations, access modes, and record formats of COBOL files

File organization	Sequential access	Random access	Dynamic access	Fixed length	Variable length
QSAM (physical sequential)	X			X	X
Line sequential	X			X ¹	X
VSAM sequential (ESDS)	X			X	X
VSAM indexed (KSDS)	X	X	X	X	X
VSAM relative (RRDS)	X	X	X	X	X
1. The data itself is in variable format but can be read into and written from COBOL fixed-length records.					

RELATED REFERENCES

“Format for coding input and output” on page 156
 “Control characters in line-sequential files” on page 214

Format for coding input and output

The following example shows the general format of input-output coding. Explanations of the user-supplied information are shown after the code.

```
IDENTIFICATION DIVISION.  
  . . .  
ENVIRONMENT DIVISION.  
INPUT-OUTPUT SECTION.  
FILE-CONTROL.  
  SELECT filename ASSIGN TO assignment-name (1) (2)  
  ORGANIZATION IS org ACCESS MODE IS access (3) (4)  
  FILE STATUS IS file-status (5)  
  . . .  
DATA DIVISION.  
FILE SECTION.  
FD filename  
01 recordname (6)  
   nn . . . fieldlength & type (7) (8)  
   nn . . . fieldlength & type  
  . . .  
WORKING-STORAGE SECTION  
01 file-status PICTURE 99.  
  . . .  
PROCEDURE DIVISION.  
  . . .  
  OPEN iomode filename (9)  
  . . .  
  READ filename  
  . . .  
  WRITE recordname  
  . . .  
  CLOSE filename  
  . . .  
  STOP RUN.
```

The user-supplied information in the code above is described below:

(1) *filename*

Any legal COBOL name. You must use the same file-name in the SELECT clause and in the FD entry, and in the READ, OPEN, and CLOSE statements. In addition, the file-name is required if you use the START or DELETE statements. This name is not necessarily the actual name of the data set as known to the system. Each file requires its own SELECT clause, FD entry, and input-output statements.

(2) *assignment-name*

Any name you choose, provided that it follows COBOL and system naming rules. The name can be 1 - 30 characters long if it is a user-defined word, or 1 - 160 characters long if it is a literal. You code the *name* part of the *assignment-name* in a DD statement, in an ALLOCATE command (TSO), or as an environment variable (for example, in an export command) (z/OS UNIX).

(3) *org* The organization can be SEQUENTIAL, LINE SEQUENTIAL, INDEXED, or RELATIVE. This clause is optional for QSAM files.

(4) *access*

The access mode can be SEQUENTIAL, RANDOM, or DYNAMIC. For sequential file processing, including line-sequential, you can omit this clause.

(5) *file-status*

The COBOL file status key. You can specify the file status key as a

two-character category alphanumeric or category national item, or as a two-digit zoned decimal (USAGE DISPLAY) or national decimal (USAGE NATIONAL) item.

(6) *recordname*

The name of the record used in the WRITE or REWRITE statements.

(7) *fieldlength*

The logical length of the field.

(8) *type*

The record format of the file. If you break the record entry beyond the level-01 description, map each element accurately against the fields in the record.

(9) *iomode*

The INPUT or OUTPUT mode. If you are only reading from a file, code INPUT. If you are only writing to a file, code OUTPUT or EXTEND. If you are both reading and writing, code I-0, except for organization LINE SEQUENTIAL.

RELATED TASKS

Chapter 9, "Processing QSAM files," on page 159

Chapter 10, "Processing VSAM files," on page 185

Chapter 11, "Processing line-sequential files," on page 213

Allocating files

For any type of file (sequential, line sequential, indexed, or relative) in your z/OS or z/OS UNIX applications, you can define the external name with either a ddname or an environment-variable name. The external name is the name in the *assignment-name* of the ASSIGN clause.

If the file is in the z/OS UNIX file system, you can use either a DD definition or an environment variable to define the file by specifying its path name with the PATH keyword.

The environment-variable name must be uppercase. The allowable attributes for its value depend on the organization of the file being defined.

Because you can define the external name in either of two ways, the COBOL run time goes through the following steps to find the definition of the file:

1. If the ddname is explicitly allocated, it is used. The definition can be from a DD statement in JCL, an ALLOCATE command from TSO/E, or a user-initiated dynamic allocation.
2. If the ddname is not explicitly allocated and an environment variable of the same name is set, the value of the environment variable is used.

The file is dynamically allocated using the attributes specified by the environment variable. At a minimum, you must specify either the PATH() or DSN() option. All options and attributes must be in uppercase, except for the *path-name* suboption of the PATH option, which is case sensitive. You cannot specify a temporary data-set name in the DSN() option.

File status code 98 results from any of the following cases:

- The contents (including a value of null or all blanks) of the environment variable are not valid.
- The dynamic allocation of the file fails.
- The dynamic deallocation of the file fails.

The COBOL run time checks the contents of the environment variable at each OPEN statement. If a file with the same external name was dynamically allocated by a previous OPEN statement, and the contents of the environment variable have changed since that OPEN, the run time dynamically deallocates the previous allocation and reallocates the file using the options currently set in the environment variable. If the contents of the environment variable have not changed, the run time uses the current allocation.

3. If neither a ddname nor an environment variable is defined, the following steps occur:
 - a. If the allocation is for a QSAM file and the CBLQDA runtime option is in effect, CBLQDA dynamic allocation processing takes place for those eligible files. This type of "implicit" dynamic allocation persists for the life of the run unit and cannot be reallocated.
 - b. Otherwise, the allocation fails.

The COBOL run time deallocates all dynamic allocations at run unit termination, except for implicit CBLQDA allocations.

RELATED TASKS

"Setting and accessing environment variables" on page 464

"Defining and allocating QSAM files" on page 174

"Dynamically creating QSAM files" on page 171

"Allocating VSAM files" on page 206

Checking for input or output errors

After each input or output statement is performed, the file status key is updated with a value that indicates the success or failure of the operation.

Using a FILE STATUS clause, test the file status key after each input or output statement, and call an error-handling procedure if a nonzero file status code is returned. With VSAM files, you can use a second data item in the FILE STATUS clause to get additional VSAM status code information.

Another way of handling errors in input and output operations is to code ERROR (synonymous with EXCEPTION) declaratives.

RELATED TASKS

"Handling errors in input and output operations" on page 241

"Coding ERROR declaratives" on page 244

"Using file status keys" on page 245

Chapter 9. Processing QSAM files

Queued sequential access method (QSAM) files are unkeyed files in which the records are placed one after another, according to entry order.

Your program can process these files only sequentially, retrieving (with the READ statement) records in the same order as they are in the file. Each record is placed after the preceding record. To process QSAM files in your program, use COBOL language statements that:

- Identify and describe the QSAM files in the ENVIRONMENT DIVISION and the DATA DIVISION.
- Process the records in these files in the PROCEDURE DIVISION.

After you have created a record, you cannot change its length or its position in the file, and you cannot delete it. You can, however, update QSAM files on direct-access storage devices (using REWRITE), though not in the z/OS UNIX file system.

QSAM files can be on tape, direct-access storage devices (DASDs), unit-record devices, and terminals. QSAM processing is best for tables and intermediate storage.

You can also access byte-stream files in the z/OS UNIX file system using QSAM. These files are binary byte-oriented sequential files with no record structure. The record definitions that you code in your COBOL program and the length of the variables that you read into and write from determine the amount of data transferred.

RELATED CONCEPTS

z/OS DFSMS: Using Data Sets (Access methods)

RELATED TASKS

“Defining QSAM files and records in COBOL”

“Coding input and output statements for QSAM files” on page 170

“Handling errors in QSAM files” on page 174

“Working with QSAM files” on page 174

“Accessing z/OS UNIX files using QSAM” on page 181

“Processing QSAM ASCII files on tape” on page 182

Defining QSAM files and records in COBOL

Use the FILE-CONTROL entry to define the files in a COBOL program as QSAM files, and to associate the files with their external file-names.

An *external file-name* (a ddname or environment variable name) is the name by which a file is known to the operating system. In the following example, COMMUTER-FILE-MST is your program's name for the file; COMMUTR is the external name:

```
FILE-CONTROL.  
  SELECT COMMUTER-FILE-MST  
  ASSIGN TO S-COMMUTR  
  ORGANIZATION IS SEQUENTIAL  
  ACCESS MODE IS SEQUENTIAL.
```

The ASSIGN clause *name* can include an S- before the external name to document that the file is a QSAM file. Both the ORGANIZATION and ACCESS MODE clauses are optional.

RELATED TASKS

“Establishing record formats”

“Setting block sizes” on page 167

Establishing record formats

In the FD entry in the DATA DIVISION, code the record format and indication of whether the records are blocked. In the associated record description entry or entries, specify the *record-name* and record length.

You can code a record format of F, V, S, or U in the RECORDING MODE clause. COBOL determines the record format from the RECORD clause or from the record descriptions associated with the FD entry for the file. If you want the records to be blocked, code the BLOCK CONTAINS clause in the FD entry.

The following example shows how the FD entry might look for a file that has fixed-length records:

```
FILE SECTION.  
FD  COMMUTER-FILE-MST  
    RECORDING MODE IS F  
    BLOCK CONTAINS 0 RECORDS  
    RECORD CONTAINS 80 CHARACTERS.  
01  COMMUTER-RECORD-MST.  
    05  COMMUTER-NUMBER          PIC  X(16).  
    05  COMMUTER-DESCRIPTION     PIC  X(64).
```

A recording mode of S is not supported for files in the z/OS UNIX file system. The above example is appropriate for such a file.

RELATED CONCEPTS

“Logical records”

RELATED TASKS

“Requesting fixed-length format” on page 161

“Requesting variable-length format” on page 162

“Requesting spanned format” on page 164

“Requesting undefined format” on page 166

“Defining QSAM files and records in COBOL” on page 159

RELATED REFERENCES

“FILE SECTION entries” on page 12

Logical records

COBOL uses the term *logical record* in a slightly different way than z/OS QSAM.

For format-V and format-S files, a QSAM logical record includes a 4-byte prefix in front of the user data portion of the record that is not included in the definition of a COBOL logical record.

For format-F and format-U files, and for byte-stream files in the z/OS UNIX file system, the definitions of QSAM logical record and COBOL logical record are identical.

In this information, *QSAM logical record* refers to the QSAM definition, and *logical record* refers to the COBOL definition.

RELATED REFERENCES

- “Layout of format-F records” on page 162
- “Layout of format-V records” on page 163
- “Layout of format-S records” on page 166
- “Layout of format-U records” on page 167

Requesting fixed-length format

Fixed-length records are in format F. Use RECORDING MODE F to explicitly request this format.

You can omit the RECORDING MODE clause. The compiler determines the recording mode to be F if the length of the largest level-01 record associated with the file is not greater than the block size coded in the BLOCK CONTAINS clause, and you take one of the following actions:

- Use the RECORD CONTAINS *integer* clause (format-1 RECORD clause) to indicate the length of the record in bytes.
When you use this clause, the file is always fixed format with record length *integer* even if there are multiple level-01 record description entries with different lengths associated with the file.
- Omit the RECORD CONTAINS *integer* clause, but code the same fixed size and no OCCURS DEPENDING ON clause for all level-01 record description entries associated with the file. This fixed size is the record length.

In an unblocked format-F file, the logical record is the same as the block.

In a blocked format-F file, the number of logical records in a block (the *blocking factor*) is constant for every block in the file except the last block, which might be shorter.

Files in the z/OS UNIX file system are never blocked.

RELATED CONCEPTS

“Logical records” on page 160

RELATED TASKS

- “Requesting variable-length format” on page 162
- “Requesting spanned format” on page 164
- “Requesting undefined format” on page 166
- “Establishing record formats” on page 160

RELATED REFERENCES

“Layout of format-F records” on page 162

Layout of format-F records:

The layout of format-F QSAM records is shown below.

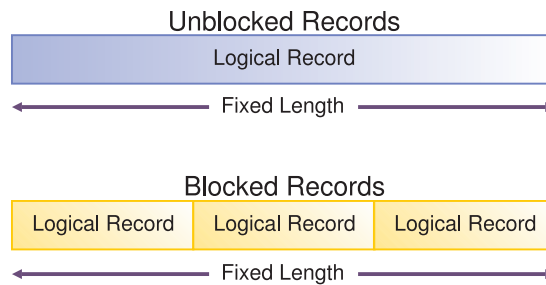

RELATED CONCEPTS

"Logical records" on page 160

RELATED TASKS

"Requesting fixed-length format" on page 161

z/OS DFSMS: Using Data Sets (Fixed-length record formats)

RELATED REFERENCES

"Layout of format-V records" on page 163

"Layout of format-S records" on page 166

"Layout of format-U records" on page 167

Requesting variable-length format

Variable-length records can be in format V or format D. Format-D records are variable-length records on ASCII tape files. Format-D records are processed in the same way as format-V records.

Use RECORDING MODE V for both. You can omit the RECORDING MODE clause. The compiler determines the recording mode to be V if the largest level-01 record associated with the file is not greater than the block size in the BLOCK CONTAINS clause, and you take one of the following actions:

- Use the RECORD IS VARYING clause (format-3 RECORD clause).
If you provide values for *integer-1* and *integer-2* (RECORD IS VARYING FROM *integer-1* TO *integer-2*), the maximum record length is the value coded for *integer-2* regardless of the lengths coded in the level-01 record description entries associated with the file. The integer sizes indicate the minimum and maximum record lengths in numbers of bytes regardless of the USAGE of the data items in the record.
If you omit *integer-1* and *integer-2*, the maximum record length is determined to be the size of the largest level-01 record description entry associated with the file.
- Use the RECORD CONTAINS *integer-1* TO *integer-2* clause (format-2 RECORD clause).
Make *integer-1* and *integer-2* match the minimum length and the maximum length in bytes of the level-01 record description entries associated with the file. The maximum record length is the *integer-2* value.
- Omit the RECORD clause, but code multiple level-01 records (associated with the file) that are of different sizes or contain an OCCURS DEPENDING ON clause.
The maximum record length is determined to be the size of the largest level-01 record description entry associated with the file.

When you specify a READ INTO statement for a format-V file, the record size read for that file is used in the MOVE statement generated by the compiler. Consequently, you might not get the result you expect if the record just read does not correspond to the level-01 record description. All other rules of the MOVE statement apply. For example, when you specify a MOVE statement for a format-V record read in by the READ statement, the size of the record moved corresponds to its level-01 record description.

When you specify a READ statement for a format-V file followed by a MOVE of the level-01 record, the actual record length is not used. The program will attempt to move the number of bytes described by the level-01 record description. If this number exceeds the actual record length and extends outside the area addressable by the program, results are unpredictable. If the number of bytes described by the level-01 record description is shorter than the physical record read, truncation of bytes beyond the level-01 description occurs. To find the actual length of a variable-length record, specify *data-name-1* in format 3 of the RECORD clause of the File Definition (FD).

RELATED TASKS

- “Requesting fixed-length format” on page 161
- “Requesting spanned format” on page 164
- “Requesting undefined format” on page 166
- “Establishing record formats” on page 160

RELATED REFERENCES

- “FILE SECTION entries” on page 12
- “Layout of format-V records”
- Enterprise COBOL Migration Guide* (Moving from the VS COBOL II run time)

Layout of format-V records:

Format-V QSAM records have control fields that precede the data. The QSAM logical record length is determined by adding 4 bytes (for the control fields) to the record length defined in your program. However, you must not include these 4 bytes in the description of the record and record length.

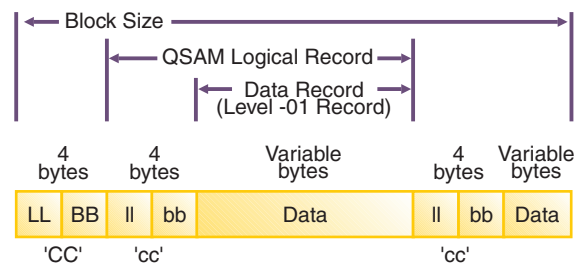

- CC** The first 4 bytes of each block contain control information.
 - LL** Represents 2 bytes designating the length of the block (including the **CC** field).
 - BB** Represents 2 bytes reserved for system use.
- cc** The first 4 bytes of each logical record contain control information.
 - II** Represents 2 bytes designating the logical record length (including the **cc** field).
 - bb** Represents 2 bytes reserved for system use.

The block length is determined as follows:

- Unblocked format-V records: CC + cc + the data portion
- Blocked format-V records: CC + the cc of each record + the data portion of each record

The operating system provides the control bytes when the file is written; the control byte fields do not appear in the description of the logical record in the DATA DIVISION of your program. COBOL allocates input and output buffers that are large enough to accommodate the control bytes. These control fields in the buffer are not available for you to use in your program. When variable-length records are written on unit record devices, control bytes are neither printed nor punched. They appear however on other external storage devices, as well as in buffer areas of storage. If you move V-mode records from an input buffer to a WORKING-STORAGE area, the records will be moved without the control bytes.

Files in the z/OS UNIX file system are never blocked.

RELATED CONCEPTS

“Logical records” on page 160

RELATED TASKS

“Requesting variable-length format” on page 162

RELATED REFERENCES

“Layout of format-F records” on page 162

“Layout of format-S records” on page 166

“Layout of format-U records” on page 167

Requesting spanned format

Spanned records are in format S. A *spanned record* is a QSAM logical record that can be contained in one or more physical blocks.

You can code RECORDING MODE S for spanned records in QSAM files that are assigned to magnetic tape or to direct access devices. Do not request spanned records for files in the z/OS UNIX file system. You can omit the RECORDING MODE clause. The compiler determines the recording mode to be S if the maximum record length (in bytes) plus 4 is greater than the block size set in the BLOCK CONTAINS clause.

For files with format S in your program, the compiler determines the maximum record length with the same rules as are used for format V. The length is based on your usage of the RECORD clause.

When creating files that contain format-S records and a record is larger than the remaining space in a block, COBOL writes a segment of the record to fill the block. The rest of the record is stored in the next block or blocks depending on its length. COBOL supports QSAM spanned records up to 32,760 bytes in length.

When retrieving files that have format-S records, a program can retrieve only complete records.

Benefits of format-S files: You can efficiently use external storage and still organize your files with logical record lengths by defining files with format-S records:

- You can set block lengths to efficiently use track capacities on direct access devices.
- You are not required to adjust the logical record lengths to device-dependent physical block lengths. One logical record can span two or more physical blocks.
- You have greater flexibility when you want to transfer logical records between direct access storage types.

You will, however, have additional overhead in processing format-S files.

Format-S files and READ INTO: When you specify a READ INTO statement for a format-S file, the compiler generates a MOVE statement that uses the size of the record that it just read for that file. If the record just read does not correspond to the level-01 record description, you might not get the result that you expect. All other rules of the MOVE statement apply.

RELATED CONCEPTS

“Logical records” on page 160
 “Spanned blocked and unblocked files”

RELATED TASKS

“Requesting fixed-length format” on page 161
 “Requesting variable-length format” on page 162
 “Requesting undefined format” on page 166
 “Establishing record formats” on page 160

RELATED REFERENCES

“FILE SECTION entries” on page 12
 “Layout of format-S records” on page 166

Spanned blocked and unblocked files:

A spanned blocked QSAM file is made up of blocks, each containing one or more logical records or segments of logical records. A spanned unblocked file is made up of physical blocks, each containing one logical record or one segment of a logical record.

In a spanned blocked file, a logical record can be either fixed or variable in length, and its size can be smaller than, equal to, or larger than the physical block size. There are no required relationships between logical records and physical block sizes.

In a spanned unblocked file, the logical records can be either fixed or variable in length. When the physical block contains one logical record, the block length is determined by the logical record size. When a logical record has to be segmented, the system always writes the largest physical block possible. The system segments the logical record when the entire logical record cannot fit on a track.

RELATED CONCEPTS

“Logical records” on page 160

RELATED TASKS

“Requesting spanned format” on page 164

Layout of format-S records:

Spanned records are preceded by control fields, as explained below.

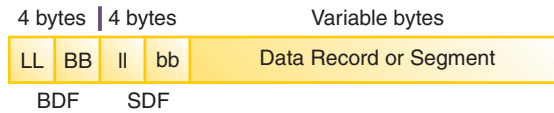

Each block is preceded by a 4-byte block descriptor field ('BDF' in the image above). There is only one block descriptor field at the beginning of each physical block.

Each segment of a record in a block is preceded by a 4-byte segment descriptor field ('SDF' in the image) even if the segment is the entire record. There is one segment descriptor field for each record segment in the block. The segment descriptor field also indicates whether the segment is the first, the last, or an intermediate segment.

You do not describe these fields in the DATA DIVISION, and the fields are not available for you to use in your COBOL program.

RELATED TASKS

"Requesting spanned format" on page 164

RELATED REFERENCES

"Layout of format-F records" on page 162

"Layout of format-V records" on page 163

"Layout of format-U records" on page 167

Requesting undefined format

Format-U records have undefined or unspecified characteristics. With format U, you can process blocks that do not meet format-F or format-V specifications.

When you use format-U files, each block of storage is one logical record. A read of a format-U file returns the entire block as a record. A write to a format-U file writes a record out as a block. The compiler determines the recording mode to be U only if you code RECORDING MODE U.

It is recommended that you not use format U to update or extend a file that was written with a different record format. If you use format U to update a file that was written with a different format, the RECFM value in the data-set label could be changed or the data set could contain records written in different formats.

The record length is determined in your program based on how you use the RECORD clause:

- If you use the RECORD CONTAINS *integer* clause (format-1 RECORD clause), the record length is the *integer* value regardless of the lengths of the level-01 record description entries associated with the file. The integer size indicates the number of bytes in a record regardless of the USAGE of its data items.
- If you use the RECORD IS VARYING clause (format-3 RECORD clause), the record length is determined based on whether you code *integer-1* and *integer-2*.

If you code *integer-1* and *integer-2* (RECORD IS VARYING FROM *integer-1* TO *integer-2*), the maximum record length is the *integer-2* value regardless of the lengths of the level-01 record description entries associated with the file. The

integer sizes indicate the minimum and maximum record lengths in numbers of bytes regardless of the USAGE of the data items in the record.

If you omit *integer-1* and *integer-2*, the maximum record length is determined to be the size of the largest level-01 record description entry associated with the file.

- If you use the RECORD CONTAINS *integer-1* TO *integer-2* clause (format-2 RECORD clause), with *integer-1* and *integer-2* matching the minimum length and the maximum length in bytes of the level-01 record description entries associated with the file, the maximum record length is the *integer-2* value.
- If you omit the RECORD clause, the maximum record length is determined to be the size of the largest level-01 record description entry associated with the file.

Format-U files and READ INTO: When you specify a READ INTO statement for a format-U file, the compiler generates a MOVE statement that uses the size of the record that it just read for that file. If the record just read does not correspond to the level-01 record description, you might not get the result that you expect. All other rules of the MOVE statement apply.

RELATED TASKS

- “Requesting fixed-length format” on page 161
- “Requesting variable-length format” on page 162
- “Requesting spanned format” on page 164
- “Establishing record formats” on page 160

RELATED REFERENCES

- “FILE SECTION entries” on page 12
- “Layout of format-U records”

Layout of format-U records:

With format-U, each block of external storage is handled as a logical record. There are no record-length or block-length fields.

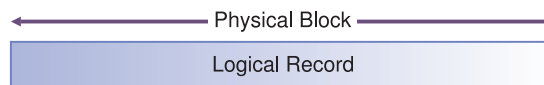

RELATED CONCEPTS

- “Logical records” on page 160

RELATED TASKS

- “Requesting undefined format” on page 166

RELATED REFERENCES

- “Layout of format-F records” on page 162
- “Layout of format-V records” on page 163
- “Layout of format-S records” on page 166

Setting block sizes

In COBOL, you establish the size of a physical record by using the BLOCK CONTAINS clause. If you omit this clause, the compiler assumes that the records are not blocked.

Blocking QSAM files on tape and disk can enhance processing speed and minimize storage requirements. You can block files in the z/OS UNIX file system, PDSE members, and spooled data sets, but doing so has no effect on how the system stores the data.

If you set the block size explicitly in the BLOCK CONTAINS clause, the size must not be greater than the maximum block size for the device. If you specify the CHARACTERS phrase of the BLOCK CONTAINS clause, size must indicate the number of bytes in a record regardless of the USAGE of the data items in the record. The block size that is set for a format-F file must be an integral multiple of the record length.

If your program uses QSAM files on tape, use a physical block size of at least 12 to 18 bytes. Otherwise, the block will be skipped over when a parity check occurs during one of the following actions:

- Reading a block of records of fewer than 12 bytes
- Writing a block of records of fewer than 18 bytes

Larger blocks generally give you better performance. Blocks of only a few kilobytes are particularly inefficient; you should choose a block size of at least tens of kilobytes. If you specify record blocking and omit the block size, the system will pick a block size that is optimal for device utilization and for data transfer speed.

Letting z/OS determine block size: To maximize performance, do not explicitly set the block size for a blocked file in your COBOL source program. For new blocked data sets, it is simpler to allow z/OS to supply a system-determined block size. To use this feature, follow these guidelines:

- Code BLOCK CONTAINS 0 in your source program or compile with the BLOCK0 option. For details about BLOCK0, see “BLOCK0” on page 310.
- Do not code RECORD CONTAINS 0 in your source program.
- Do not code a BLKSIZE value in the JCL DD statement.

Setting block size explicitly: If you prefer to set a block size explicitly, your program will be most flexible if you follow these guidelines:

- Code BLOCK CONTAINS 0 in your source program.
- Code a BLKSIZE value in the ddname definition (the JCL DD statement).

For extended-format data sets on z/OS, z/OS DFSMS adds a 32-byte block suffix to the physical record. If you specify a block size explicitly (using JCL or ISPF), do not include the size of this block suffix in the block size. This block suffix is not available for you to use in your program. z/OS DFSMS allocates the space used to read in the block suffix. However, when you calculate how many blocks of an extended-format data set will fit on a track of a direct-access device, you need to include the size of the block suffix in the block size.

If you specify a block size that is larger than 32760 directly in the BLOCK CONTAINS clause or indirectly with the use of BLOCK CONTAINS *n* RECORDS, the OPEN of the data set fails with file status code 90 unless you define the data set to be on tape.

For existing blocked data sets, it is simplest to:

- Code BLOCK CONTAINS 0 in your source program.
- Not code a BLKSIZE value in the ddname definition.

When you omit the BLKSIZE from the ddname definition, the block size is automatically obtained by the system from the data-set label.

Taking advantage of LBI: You can improve the performance of tape data sets by using the large block interface (LBI) for large block sizes. When the LBI is available, the COBOL run time automatically uses this facility for those tape files for which you use system-determined block size. LBI is also used for those files for which you explicitly define a block size in JCL or a BLOCK CONTAINS clause. Use of the LBI allows block sizes to exceed 32760 if the tape device supports it.

The LBI is not used in all cases. An attempt to use a block size greater than 32760 in the following cases is diagnosed at compile time or results in a failure at OPEN:

- Spanned records
- OPEN I-O

Using a block size that exceeds 32760 might result in your not being able to read the tape on another system. A tape that you create with a block size greater than 32760 can be read only on a system that has a tape device that supports block sizes greater than 32760. If you specify a block size that is too large for the file, the device, or the operating system level, a runtime message is issued.

To limit a system-determined block size to 32760, do not specify BLKSIZE anywhere, and set one of the following items to 32760:

- The BLKSZLIM keyword on the DD statement for the data set
- BLKSZLIM for the data class by using the BLKSZLIM keyword (must be set by your systems programmer)
- A block-size limit for the system in the DEVSUPxx member of SYS1.PARMLIB by using the keyword TAPEBLKSZLIM (must be set by your systems programmer)

The block-size limit is the first nonzero value that the compiler finds by checking these items.

If no BLKSIZE or BLKSZLIM value is available from any source, the system limits BLKSIZE to 32760. You can then enable block sizes larger than 32760 in one of two ways:

- Specify a BLKSZLIM value greater than 32760 in the DD statement for the file and use BLOCK CONTAINS 0 in your COBOL source.
- Specify a value greater than 32760 for the BLKSIZE in the DD statement or in the BLOCK CONTAINS clause in your COBOL source.

BLKSZLIM is device-independent.

Block size and the DCB RECFM subparameter: Under z/OS, you can code the S or T option in the DCB RECFM subparameter:

- Use the S (standard) option in the DCB RECFM subparameter for a format-F record with only standard blocks (ones that have no truncated blocks or unfilled tracks in the file, except for the last block of the file). S is also supported for records on tape. It is ignored if the records are not on DASD or tape.
Using this standard block option might improve input-output performance, especially for direct-access devices.
- The T (track overflow) option for QSAM files is no longer useful.

RELATED TASKS

“Defining QSAM files and records in COBOL” on page 159
z/OS DFSMS: Using Data Sets

RELATED REFERENCES

“FILE SECTION entries” on page 12

“BLOCK0” on page 310

BLOCK CONTAINS clause (*Enterprise COBOL Language Reference*)

Coding input and output statements for QSAM files

You can code the following input and output statements to process a QSAM file or a byte-stream file in the z/OS UNIX file system using QSAM: OPEN, READ, WRITE, REWRITE, and CLOSE.

OPEN Initiates the processing of files. You can open all QSAM files as INPUT, OUTPUT, or EXTEND (depending on device capabilities).

You can also open QSAM files on direct access storage devices as I-0. You cannot open z/OS UNIX files as I-0; a file status of 37 results if you attempt to do so.

READ Reads a record from the file. With sequential processing, your program reads one record after another in the same order in which they were entered when the file was created.

WRITE Creates a record in the file. Your program writes new records to the end of the file.

REWRITE

Updates a record. You cannot update a file in the z/OS UNIX file system using REWRITE.

CLOSE Releases the connection between the file and your program.

RELATED TASKS

“Opening QSAM files”

“Dynamically creating QSAM files” on page 171

“Adding records to QSAM files” on page 172

“Updating QSAM files” on page 172

“Writing QSAM files to a printer or spooled data set” on page 172

“Closing QSAM files” on page 173

RELATED REFERENCES

OPEN statement (*Enterprise COBOL Language Reference*)

READ statement (*Enterprise COBOL Language Reference*)

WRITE statement (*Enterprise COBOL Language Reference*)

REWRITE statement (*Enterprise COBOL Language Reference*)

CLOSE statement (*Enterprise COBOL Language Reference*)

File status key (*Enterprise COBOL Language Reference*)

Opening QSAM files

Before a program can use any READ, WRITE, or REWRITE statements to process records in a file, it must first open the file by using an OPEN statement.

An OPEN statement works if both of the following conditions are true:

- The file is available or has been dynamically allocated.
- The *fixed file attributes* coded in the ddname definition or the data-set label for the file match the attributes coded for that file in the SELECT clause and FD entry. Mismatches in the file-organization attributes, code set, maximum record size, or record format (fixed or variable) result in file status code 39, and the failure of

the OPEN statement. Mismatches in maximum record size and record format are not errors when opening files in the z/OS UNIX file system.

For fixed-length QSAM files, if you code RECORD CONTAINS 0 in the FD entry, the record size attributes are not in conflict. The record size is taken from the DD statement or the data-set label, and the OPEN statement is successful.

Code CLOSE WITH LOCK so that the file cannot be opened again while the program is running.

Use the REVERSED option of the OPEN statement to process tape files in reverse order. The file is positioned at the end, and READ statements read the data records in reverse order, starting with the last record. The REVERSED option is supported only for files that have fixed-length records.

RELATED TASKS

“Dynamically creating QSAM files”

“Ensuring that file attributes match your program” on page 178

RELATED REFERENCES

OPEN statement (*Enterprise COBOL Language Reference*)

Dynamically creating QSAM files

Sometimes a QSAM file is unavailable on the operating system, but a COBOL program specifies that the file be created. Under certain circumstances, the file is created for you dynamically.

A QSAM file is considered to be *available* on z/OS when it has been identified to the operating system using a valid DD statement, an export command for an environment variable, or a TSO ALLOCATE command. Otherwise the file is *unavailable*.

Note that a DD statement with a misspelled ddname is equivalent to a missing DD statement, and an environment variable with a value that is not valid is equivalent to an unset variable.

The QSAM file is implicitly created if you use the runtime option CBLQDA and one of the following circumstances exists:

- An optional file is being opened as EXTEND or I-0.
Optional files are files that are not necessarily available each time the program is run. You define a file that is being opened in INPUT, I-0, or EXTEND mode as optional by coding the SELECT OPTIONAL clause in the FILE-CONTROL paragraph.
- The file is being opened for OUTPUT, regardless of the OPTIONAL phrase.

The file is allocated with the system default attributes established at your installation and the attributes coded in the SELECT clause and FD entry in your program.

Do not confuse this implicit allocation mechanism with the explicit dynamic allocation of files by means of environment variables. Explicit dynamic allocation requires that a valid environment variable be set. CBLQDA support is used only when the QSAM file is unavailable as defined above, which includes no valid environment variable being set.

Under z/OS, files created using the CBLQDA option are temporary data sets and do not exist after the program has run.

RELATED TASKS

“Opening QSAM files” on page 170

Adding records to QSAM files

To add to a QSAM file, open the file as EXTEND and use the WRITE statement to add records immediately after the last record in the file.

To add records to a file opened as I-0, you must first close the file and open it as EXTEND.

RELATED REFERENCES

READ statement (*Enterprise COBOL Language Reference*)

WRITE statement (*Enterprise COBOL Language Reference*)

Updating QSAM files

You can update QSAM files only if they reside on direct access storage devices. You cannot update files in the z/OS UNIX file system.

Replace an existing record with another record of the same length by doing these steps:

1. Open the file as I-0.
2. Use REWRITE to update an existing record. (The last file processing statement before REWRITE must have been a successful READ statement.)

You cannot open as I-0 an extended format data set that you allocate in compressed format.

RELATED REFERENCES

REWRITE statement (*Enterprise COBOL Language Reference*)

Writing QSAM files to a printer or spooled data set

COBOL provides language statements to control the size of a printed page and control the vertical positioning of records.

Controlling the page size: Use the LINAGE clause of the FD entry to control the size of your printed page: the number of lines in the top and bottom margins and in the footing area of the page. When you use the LINAGE clause, COBOL handles the file as if you had also requested the ADV compiler option.

If you use the LINAGE clause in combination with WRITE BEFORE | AFTER ADVANCING *nn* LINES, be careful about the values you set. With the ADVANCING *nn* LINES phrase, COBOL first calculates the sum of LINAGE-COUNTER plus *nn*. Subsequent actions depend on the size of *nn*. The END-OF-PAGE imperative phrase is performed after the LINAGE-COUNTER is increased. Consequently, the LINAGE-COUNTER could be pointing to the next logical page instead of to the current footing area when the END-OF-PAGE phrase is performed.

AT END-OF-PAGE or NOT AT END-OF-PAGE imperative phrases are performed only if the write operation completes successfully. If the write operation is unsuccessful, control is passed to the end of the WRITE statement, and all conditional phrases are omitted.

Controlling the vertical positioning of records: Use the WRITE ADVANCING statement to control the vertical positioning of each record you write on a printed page.

BEFORE ADVANCING prints the record before the page is advanced. AFTER ADVANCING prints the record after the page is advanced.

Specify the number of lines the page is advanced with an integer (or an *identifier* with a *mnemonic-name*) following ADVANCING. If you omit the ADVANCING phrase from a WRITE statement, the effect is as if you had coded:

```
AFTER ADVANCING 1 LINE
```

RELATED REFERENCES

WRITE statement (*Enterprise COBOL Language Reference*)

Closing QSAM files

Use the CLOSE statement to disconnect your program from a QSAM file. If you try to close a file that is already closed, you will get a logic error.

If you do not close a QSAM file, the file is automatically closed for you under the following conditions:

- When the run unit ends normally, the run time closes all open files that are defined in any COBOL programs in the run unit.
- If the run unit ends abnormally and the TRAP(ON) runtime option is in effect, the run time closes all open files that are defined in any COBOL programs in the run unit.
- When Language Environment condition handling has completed and the application resumes in a routine other than where the condition occurred, the run time closes all open files that are defined in any COBOL programs in the run unit that might be called again and reentered.

You can change the location where the program resumes running (after a condition is handled) by moving the resume cursor with the Language Environment CEEMRCR callable service or by using language constructs such as a C longjmp.

- When you use CANCEL for a COBOL subprogram, the run time closes any open nonexternal files that are defined in that program.
- When a COBOL subprogram with the INITIAL attribute returns control, the run time closes any open nonexternal files that are defined in that program.
- When a thread of a multithreaded application ends, both external and nonexternal files that you opened from within that same thread are closed.

File status key data items in the DATA DIVISION are set when these implicit CLOSE operations are performed, but your EXCEPTION/ERROR declarative is not invoked.

Errors: If you open a QSAM file in a multithreaded application, you must close it from the same thread of execution from which the file was opened. Attempting to close the file from a different thread results in a close failure with file-status condition 90.

RELATED REFERENCES

CLOSE statement (*Enterprise COBOL Language Reference*)

Handling errors in QSAM files

When an input statement or output statement fails, COBOL does not take corrective action for you. You choose whether your program should continue running after a less-than-severe input or output error occurs.

COBOL provides these ways for you to intercept and handle certain QSAM input and output errors:

- End-of-file phrase (AT END)
- EXCEPTION/ERROR declarative
- FILE STATUS clause
- INVALID KEY phrase

If you do not code a FILE STATUS key or a declarative, serious QSAM processing errors will cause a message to be issued and a Language Environment condition to be signaled, which will cause an abend if you specify the runtime option ABTERMENC (ABEND).

If you use the FILE STATUS clause or the EXCEPTION/ERROR declarative, code EROPT=ACC in the DCB of the DD statement for that file. Otherwise, your COBOL program will not be able to continue processing after some error conditions.

If you use the FILE STATUS clause, be sure to check the key and take appropriate action based on its value. If you do not check the key, your program might continue, but the results will probably not be what you expected.

RELATED TASKS

“Handling errors in input and output operations” on page 241

Working with QSAM files

To work with QSAM files in a COBOL program, you define and allocate the files, retrieve them, and ensure that their file attributes match those in the program. You can also use striped extended-format QSAM data sets to help improve performance.

RELATED TASKS

“Defining and allocating QSAM files”

“Retrieving QSAM files” on page 177

“Ensuring that file attributes match your program” on page 178

“Using striped extended-format QSAM data sets” on page 180

RELATED REFERENCES

“Allocation of buffers for QSAM files” on page 181

Defining and allocating QSAM files

You can define a QSAM file or a byte-stream file in the z/OS UNIX file system by using either a DD statement or an environment variable. Allocation of these files follows the general rules for the allocation of COBOL files.

When you use an environment variable, the name must be in uppercase. Specify the MVS data set in one of these ways:

- DSN(*data-set-name*)
- DSN(*data-set-name(member-name)*)

data-set-name must be fully qualified and cannot be a temporary data set (that is, it must not start with &).

Restriction: You cannot create a PDS or PDSE by using an environment variable.

You can optionally specify the following attributes in any order after DSN:

- A disposition value, one of: NEW, OLD, SHR, or MOD
- TRACKS or CYL
- SPACE(*nnn,mmm*)
- VOL(*volume-serial*)
- UNIT(*type*)
- KEEP, DELETE, CATALOG, or UNCATALOG
- STORCLAS(*storage-class*)
- MGMTCLAS(*management-class*)
- DATACLAS(*data-class*)

You can use either an environment variable or a DD definition to define a file in the z/OS UNIX file system. To do so, define one of the following items with a name that matches the external name in the ASSIGN clause:

- A DD allocation that uses PATH=*'absolute-path-name'* and FILEDATA=BINARY
- An environment variable with a value PATH(*pathname*), where *pathname* is an absolute path name (starting with /)

For compatibility with releases of COBOL before COBOL for OS/390 & VM Version 2 Release 2, you can also specify FILEDATA=TEXT when using a DD allocation for z/OS UNIX files, but this use is not recommended. To process text files in the z/OS UNIX file system, use LINE SEQUENTIAL organization. If you do use QSAM to process text files in the z/OS UNIX file system, you cannot use environment variables to define the files.

When you define a QSAM file, use the parameters as shown below.

Table 20. QSAM file allocation

What you want to do	DD parameter to use	EV keyword to use
Name the file.	DSNAME (data-set name)	DSN
Select the type and quantity of input-output devices to be allocated for the file.	UNIT	UNIT for type only
Give instructions for the volume in which the file will reside and for volume mounting.	VOLUME (or let the system choose an output volume)	VOL
Allocate the type and amount of space the file needs. (Only for direct-access storage devices.)	SPACE	SPACE for the amount of space (primary and secondary only); TRACKS or CYL for the type of space
Specify the type and some of the contents of the label associated with the file.	LABEL	n/a
Indicate whether you want to catalog, pass, or keep the file after the job step is completed.	DISP	NEW, OLD, SHR, MOD plus KEEP, DELETE, CATALOG, or UNCATALOG

Table 20. QSAM file allocation (continued)

What you want to do	DD parameter to use	EV keyword to use
Complete any data control block information that you want to add.	DCB subparameters	n/a

Some of the information about the QSAM file must always be coded in the FILE-CONTROL paragraph, the FD entry, and other COBOL clauses. Other information must be coded in the DD statement or environment variable for output files. For input files, the system can obtain information from the file label (for standard label files). If DCB information is provided in the DD statement for input files, it overrides information on the data-set label. For example, the amount of space allocated for a new direct-access device file can be set in the DD statement by the SPACE parameter.

You cannot express certain characteristics of QSAM files in the COBOL language, but you can code them in the DD statement for the file by using the DCB parameter. Use the subparameters of the DCB parameter to provide information that the system needs for completing the data set definition, including the following items:

- Block size (BLKSIZE=), if BLOCK CONTAINS 0 RECORDS was coded at compile time (recommended)
- Options to be executed if an error occurs in reading or writing a record
- TRACK OVERFLOW or standard blocks
- Mode of operation for a card reader or punch

DCB attributes coded for a DD DUMMY do not override those coded in the FD entry of your COBOL program.

“Example: setting and accessing environment variables” on page 466

RELATED TASKS

“Setting block sizes” on page 167

“Defining QSAM files and records in COBOL” on page 159

“Allocating files” on page 157

RELATED REFERENCES

“Parameters for creating QSAM files” on page 177

MVS Program Management: User's Guide and Reference

Parameters for creating QSAM files

The following DD statement parameters are frequently used to create QSAM files.

```
DSNAME= [ dataset-name
DSN=     dataset-name(member-name)
         &&name
         &&name(member-name) ]

UNIT= ( name[,unitcount] )

VOLUME= ( [PRIVATE] [,RETAIN] [,vol-sequence-num] [,volume-count] ...
VOL=     ... [ ,SER=(volume-serial[,volume-serial]...) ] )
         [ ,REF=[ dsname
                 *.ddname
                 *.stepname.ddname
                 *.stepname.procstep.ddname ] ] )

SPACE= ( [ TRK
          CYL
          average-record-length ] , (primary-quantity[,secondary-quantity][,directory-quantity]))

LABEL= ( [Data-set-sequence-number,] [ NL
                                       SL
                                       SUL ] [ ,EXPDT= [ yyddd
                                                         yyyy/ddd ] ] )
         [ ,RETPD=xxxx ] )

DISP= ( [ NEW ] [ ,DELETE ] [ ,DELETE ] )
        [ MOD ] [ ,KEEP ] [ ,KEEP ]
               [ ,PASS ] [ ,CATLG ]
               [ ,CATLG ] )

DCB= ( subparameter-list )
```

RELATED TASKS

“Defining and allocating QSAM files” on page 174

Retrieving QSAM files

You retrieve QSAM files, cataloged or not, by using job control statements or environment variables.

Cataloged files

All data set information, such as volume and space, is stored in the catalog and file label. All you have to code are the data set name and a disposition. When you use a DD statement, this is the DSNAME parameter and the DISP parameter. When you use an environment variable, this is the DSN parameter and one of the parameters OLD, SHR, or MOD.

Noncataloged files

Some information is stored in the file label, but you must code the unit and volume information, and the *dsname* and disposition.

If you are using JCL, and you created the file in the current job step or in a previous job step in the current job, you can refer to the previous DD statement for most of the data set information. You do, however, need to code DSNAME and DISP.

RELATED REFERENCES

“Parameters for retrieving QSAM files” on page 178

Parameters for retrieving QSAM files

The following DD statement parameters are used to retrieve previously created files.

```
DSNAME= [ dataset-name
DSN=     dataset-name(member-name)
         *.ddname
         *.stepname.ddname
         &&name
         &&name(member-name) ]

UNIT=   ( name[,unitcount] )

VOLUME= ( subparameter-list )
VOL=

LABEL=  ( subparameter-list )

DISP=   ( [ OLD
           SHR
           MOD ] [ ,DELETE
                 ,KEEP
                 ,PASS
                 ,CATLG
                 ,UNCATLG ] [ ,DELETE
                              ,KEEP
                              ,CATLG
                              ,UNCATLG ] )

DCB=    ( subparameter-list )
```

RELATED TASKS

“Retrieving QSAM files” on page 177

Ensuring that file attributes match your program

When the fixed file attributes in the DD statement or the data-set label and the attributes that are coded for that file in the SELECT clause and FD entry are not consistent, an OPEN statement in your program might not work.

Mismatches in the attributes for file organization, record format (fixed or variable), record length, or the code set result in file status code 39 and the failure of the OPEN statement. An exception exists for files in the z/OS UNIX file system: mismatches in record format and record length do not cause an error.

To prevent common file status 39 problems, follow the guidelines for processing existing or new files.

If you have not made a file available with a DD statement or a TSO ALLOCATE command, and your COBOL program specifies that the file be created, Enterprise COBOL dynamically allocates the file. When the file is opened, the file attributes that are coded in your program are used. You do not have to worry about file attribute conflicts.

Remember that information in the JCL or environment variable overrides information in the data-set label.

RELATED TASKS

“Processing existing files” on page 179

“Processing new files” on page 180

“Opening QSAM files” on page 170

RELATED REFERENCES

“FILE SECTION entries” on page 12

Processing existing files

When your program processes an existing file, code the description of the file in your COBOL program to be consistent with the file attributes of the data set. Use the guidelines below to define the maximum record length.

Table 21. Maximum record length of QSAM files

For this format:	Specify this:
V or S	Exactly 4 bytes less than the length attribute of the data set
F	Same value as the length attribute of the data set
U	Same value as the length attribute of the data set

The easiest way to define variable-length (format-V) records in a program is to use the RECORD IS VARYING FROM *integer-1* TO *integer-2* clause in the FD entry and set an appropriate value for *integer-2*. Express the integer sizes in bytes regardless of the underlying USAGE of the data items in the record. For example, assume that you determine that the length attribute of the data set is 104 bytes (LRECL=104). Remembering that the maximum record length is determined from the RECORD IS VARYING clause and not from the level-01 record descriptions, you could define a format-V file in your program with this code:

```
FILE SECTION.  
FD COMMUTER-FILE-MST  
   RECORDING MODE IS V  
   RECORD IS VARYING FROM 4 TO 100 CHARACTERS.  
01 COMMUTER-RECORD-A PIC X(4).  
01 COMMUTER-RECORD-B PIC X(75).
```

Assume that the existing file in the previous example was format-U instead of format-V. If the 104 bytes are all user data, you could define the file in your program with this code:

```
FILE SECTION.  
FD COMMUTER-FILE-MST  
   RECORDING MODE IS U  
   RECORD IS VARYING FROM 4 TO 104 CHARACTERS.  
01 COMMUTER-RECORD-A PIC X(4).  
01 COMMUTER-RECORD-B PIC X(75).
```

To define fixed-length records in your program, either code the RECORD CONTAINS *integer* clause, or omit this clause and code all level-01 record descriptions to be the same fixed size. In either case, use a value that equals the value of the length attribute of the data set. If you intend to use the same program to process different files at run time, and those files have differing fixed lengths, avoid record-length conflicts by coding RECORD CONTAINS 0.

If the existing file is an ASCII data set (DCB=(OPTCD=Q)), you must use the CODE-SET clause in the FD entry for the file.

RELATED TASKS

“Processing new files” on page 180

“Requesting fixed-length format” on page 161

“Requesting variable-length format” on page 162

“Requesting undefined format” on page 166

“Opening QSAM files” on page 170

RELATED REFERENCES

“FILE SECTION entries” on page 12

Processing new files

If your COBOL program writes records to a new file that will be made available before the program runs, ensure that the file attributes in the DD statement, the environment variable, or the allocation do not conflict with the attributes in the program.

Usually you need to code only a minimum of parameters when predefining files. But if you need to explicitly set a length attribute for the data set (for example, you are using an ISPF allocation panel, or your DD statement is for a batch job in which the program uses RECORD CONTAINS 0), follow these guidelines:

- For format-V and format-S files, set a length attribute that is 4 bytes larger than that defined in the program.
- For format-F and format-U files, set a length attribute that is the same as that defined in the program.
- If you open the file as OUTPUT and write it to a printer, the compiler might add 1 byte to the record length to account for the carriage-control character, depending on the ADV compiler option and the language used in your program. In such a case, take the added byte into account when coding the LRECL value.

For example, if your program contains the following code for a file that has variable-length records, the LRECL value in the DD statement or allocation should be 54.

```
FILE SECTION.  
FD  COMMUTER-FILE-MST  
   RECORDING MODE IS V  
   RECORD CONTAINS 10 TO 50 CHARACTERS.  
01  COMMUTER-RECORD-A  PIC X(10).  
01  COMMUTER-RECORD-B  PIC X(50).
```

RELATED TASKS

“Processing existing files” on page 179

“Requesting fixed-length format” on page 161

“Requesting variable-length format” on page 162

“Requesting undefined format” on page 166

“Opening QSAM files” on page 170

“Dynamically creating QSAM files” on page 171

RELATED REFERENCES

“FILE SECTION entries” on page 12

Using striped extended-format QSAM data sets

Striped extended-format QSAM data sets can benefit applications that process files that have large amounts of data or in which the time needed for I/O operations significantly affects overall performance.

A *striped extended-format QSAM data set* is an extended-format QSAM data set that is spread over multiple volumes, thus allowing parallel data access.

For you to gain the maximum benefit from using QSAM striped data sets, z/OS DFSMS needs to be able to allocate the required number of buffers above the 16 MB line. When you develop applications that contain files allocated to QSAM striped data sets, follow these guidelines:

- Avoid using a QSAM striped data set for a file that cannot have buffers allocated above the 16 MB line.
- Omit the RESERVE clause in the FILE-CONTROL entry for the file. Doing so lets z/OS DFSMS determine the optimum number of buffers for the data set.
- Compile your program with the DATA(31) and RENT compiler options, and make the program object AMODE 31.
- Specify the ALL31(ON) runtime option if the file is an EXTERNAL file with format-F, format-V, or format-U records.

Note that all striped data sets are extended-format data sets, but not all extended-format data sets are striped.

RELATED TASKS

z/OS DFSMS: Using Data Sets

Allocation of buffers for QSAM files

z/OS DFSMS automatically allocates buffers for storing input and output for a QSAM file above or below the 16 MB line as appropriate for the file.

Most QSAM files have buffers allocated above the 16 MB line. Exceptions are:

- Programs running in AMODE 24.
- Programs compiled with the DATA(24) and RENT options.
- Programs compiled with the NORENT option.
- EXTERNAL files when the ALL31(OFF) runtime option is specified. To specify the ALL31(ON) runtime option, all programs in the run unit must be capable of running in 31-bit addressing mode.
- Files allocated to the TSO terminal.
- A file with format-S (spanned) records, if the file is any of the following ones:
 - An EXTERNAL file (even if ALL31(ON) is specified)
 - A file specified in a SAME RECORD AREA clause of the I-O-CONTROL paragraph
 - A blocked file that is opened I-O and updated using the REWRITE statement

RELATED CONCEPTS

“Storage and its addressability” on page 39

RELATED TASKS

“Using striped extended-format QSAM data sets” on page 180

Accessing z/OS UNIX files using QSAM

You can process byte-stream files in the z/OS UNIX file system as ORGANIZATION SEQUENTIAL files using QSAM. To do this, specify as the *assignment-name* in the ASSIGN clause either a ddname or an environment-variable name.

ddname

A DD allocation that identifies the file with the keywords PATH= and FILEDATA=BINARY

Environment-variable name

An environment variable that holds the runtime value of the z/OS UNIX file system path for the file

Observe the following restrictions:

- Spanned record format is not supported.
- OPEN I-0 and REWRITE are not supported. If you attempt one of these operations, one of the following file-status conditions results:
 - 37 from OPEN I-0
 - 47 from REWRITE (because you could not have successfully opened the file as I-0)

Usage notes

- File status 39 (fixed file attribute conflict) is not enforced for either of the following types of conflicts:
 - Record-length conflict
 - Record-type conflict (fixed as opposed to variable)
- A READ returns the number of bytes of the maximum logical record size for the file except for the last record, which might be shorter.
 For example, suppose that a file definition has level-01 record descriptions of 3, 5, and 10 bytes long, and you write the following three records: 'abc', 'defgh', and 'ijklmnopqr', in that order. The first READ of this file returns 'abcdefghij', the second READ returns 'klmnopqr ', and the third READ results in the AT END condition.

For compatibility with releases of IBM COBOL before COBOL for OS/390 & VM Version 2 Release 2, you can also specify FILEDATA=TEXT when using a DD allocation for z/OS UNIX files, but this use is not recommended. To process text files in the z/OS UNIX file system, use LINE SEQUENTIAL organization. If you use QSAM to process text files in the z/OS UNIX file system, you cannot use environment variables to define the files.

RELATED TASKS

“Allocating files” on page 157

“Defining and allocating QSAM files” on page 174

z/OS DFSMS: Using Data Sets (Using HFS data sets)

Processing QSAM ASCII files on tape

If your program processes a QSAM ASCII file, you must request the ASCII alphabet, define the record formats, and define the ddname (with JCL).

In addition, if your program processes signed numeric data items from ASCII files, define the numeric data as zoned decimal items with separate signs, that is, as USAGE DISPLAY and with the SEPARATE phrase of the SIGN clause.

The CODEPAGE compiler option has no effect on the code page used for conversions between ASCII and EBCDIC for ASCII tape support. For information about how CCSIDs used for the ASCII tape support are selected and what the default CCSIDs are, see the z/OS DFSMS documentation.

Requesting the ASCII alphabet: In the SPECIAL-NAMES paragraph, code STANDARD-1 for ASCII:

```
ALPHABET-NAME IS STANDARD-1
```

In the FD entry for the file, code:

```
CODE-SET IS ALPHABET-NAME
```

Defining the record formats: Process QSAM ASCII tape files with any of these record formats:

- Fixed length (format F)
- Undefined (format U)
- Variable length (format V)

If you use variable-length records, you cannot explicitly code format D; instead, code RECORDING MODE V. The format information is internally converted to D mode. D-mode records have a 4-byte record descriptor for each record.

Defining the ddname: Under z/OS, processing ASCII files requires special JCL coding. Code these subparameters of the DCB parameter in the DD statement:

BUFOFF=[L | n]

L A 4-byte block prefix that contains the block length (including the block prefix)

n The length of the block prefix:

- For input, from 0 through 99
- For output, either 0 or 4

Use this value if you coded BLOCK CONTAINS 0.

BLKSIZE=n

n The size of the block, including the length of the block prefix

LABEL=[AL | AUL | NL]

AL American National Standard (ANS) labels

AUL ANS and user labels

NL No labels

OPTCD=Q

Q This value is required for ASCII files and is the default if the file is created using Enterprise COBOL.

RELATED REFERENCES

z/OS DFSMS: Using Data Sets (Character data conversion)

Chapter 10. Processing VSAM files

Virtual storage access method (VSAM) is an access method for files on direct-access storage devices. With VSAM you can load files, retrieve records from files, update files, and add, replace, and delete records in files.

VSAM processing has these advantages over QSAM:

- Protection of data against unauthorized access
- Compatibility across systems
- Independence of devices (no need to be concerned with block size and other control information)
- Simpler JCL (information needed by the system is provided in integrated catalogs)
- Ability to use indexed file organization or relative file organization

The following table shows how VSAM terms differ from COBOL terms and other terms that you might be familiar with.

Table 22. Comparison of VSAM, COBOL, and non-VSAM terminology

VSAM term	COBOL term	Similar non-VSAM term
Data set	File	Data set
Entry-sequenced data set (ESDS)	Sequential file	QSAM data set
Key-sequenced data set (KSDS)	Indexed file	ISAM data set
Relative-record data set (RRDS)	Relative file	BDAM data set
Control interval		Block
Control interval size (CISZ)		Block size
Buffers (BUFNI/BUFND)		BUFNO
Access method control block (ACB)		Data control block (DCB)
Cluster (CL)		Data set
Cluster definition		Data-set allocation
AMP parameter of JCL DD statement		DCB parameter of JCL DD statement
Record size		Record length

The term *file* in this VSAM documentation refers to either a COBOL file or a VSAM data set.

If you have complex requirements or frequently use VSAM, see the VSAM publications for your operating system.

RELATED CONCEPTS

“VSAM files” on page 186

RELATED TASKS

“Defining VSAM file organization and records” on page 187

“Coding input and output statements for VSAM files” on page 193

“Handling errors in VSAM files” on page 201

“Protecting VSAM files with a password” on page 202

“Working with VSAM data sets under z/OS and z/OS UNIX” on page 202
“Improving VSAM performance” on page 209

RELATED REFERENCES

z/OS DFSMS: Using Data Sets

z/OS DFSMS Macro Instructions for Data Sets

z/OS DFSMS: Access Method Services for Catalogs

“Allocation of record areas for VSAM files” on page 209

“Extended addressability support” on page 211

VSAM files

The physical organization of VSAM data sets differs considerably from the organizations used by other access methods.

VSAM data sets are held in control intervals (CI) and control areas (CA). The size of the CI and CA is normally determined by the access method; and the way in which they are used is not visible to you.

You can use three types of file organization with VSAM:

VSAM sequential file organization

(Also referred to as VSAM *ESDS* (*entry-sequenced data set*) organization.) In VSAM sequential file organization, the records are stored in the order in which they were entered.

VSAM entry-sequenced data sets are equivalent to QSAM sequential files. The order of the records is fixed.

VSAM indexed file organization

(Also referred to as VSAM *KSDS* (*key-sequenced data set*) organization.) In a VSAM indexed file (*KSDS*), the records are ordered according to the collating sequence of an embedded prime key field, which you define. The prime key consists of one or more consecutive characters in the records. The prime key uniquely identifies the record and determines the sequence in which it is accessed with respect to other records. A prime key for a record might be, for example, an employee number or an invoice number.

VSAM relative file organization

(Also referred to as VSAM fixed-length or variable-length *RRDS* (*relative-record data set*) organization.) A VSAM relative-record data set (*RRDS*) contains records ordered by their relative key. The *relative key* is the relative record number, which represents the location of the record relative to where the file begins. The relative record number identifies the fixed- or variable-length record.

In a VSAM fixed-length *RRDS*, records are placed in a series of fixed-length slots in storage. Each slot is associated with a relative record number. For example, in a fixed-length *RRDS* that contains 10 slots, the first slot has a relative record number of 1, and the tenth slot has a relative record number of 10.

In a VSAM variable-length *RRDS*, the records are ordered according to their relative record number. Records are stored and retrieved according to the relative record number that you set.

Throughout this information, the term *VSAM relative-record data set* (or *RRDS*) is used to mean both relative-record data sets with fixed-length records and with variable-length records, unless they need to be differentiated.

The following table compares the characteristics of the different types of VSAM data sets.

Table 23. Comparison of VSAM data-set types

Characteristic	Entry-sequenced data set (ESDS)	Key-sequenced data set (KSDS)	Relative-record data set (RRDS)
Order of records	Order in which they are written	Collating sequence by key field	Order of relative record number
Access	Sequential	By key through an index	By relative record number, which is handled like a key
Alternate indexes	Can have one or more alternate indexes, although not supported in COBOL	Can have one or more alternate indexes	Cannot have alternate indexes
Relative byte address (RBA) and relative record number (RRN) of a record	RBA cannot change.	RBA can change.	RRN cannot change.
Space for adding records	Uses space at the end of the data set	Uses distributed free space for inserting records and changing their lengths in place	For fixed-length RRDS, uses empty slots in the data set For variable-length RRDS, uses distributed free space and changes the lengths of added records in place
Space from deleting records	You cannot delete a record, but you can reuse its space for a record of the same length.	Space from a deleted or shortened record is automatically reclaimed in a control interval.	Space from a deleted record can be reused.
Spanned records	Can have spanned records	Can have spanned records	Cannot have spanned records
Reuse as work file	Can be reused unless it has an alternate index, is associated with key ranges, or exceeds 123 extents per volume	Can be reused unless it has an alternate index, is associated with key ranges, or exceeds 123 extents per volume	Can be reused

RELATED TASKS

“Specifying sequential organization for VSAM files” on page 188

“Specifying indexed organization for VSAM files” on page 188

“Specifying relative organization for VSAM files” on page 190

“Defining VSAM files” on page 203

Defining VSAM file organization and records

Use an entry in the FILE-CONTROL paragraph in the ENVIRONMENT DIVISION to define the file organization and access modes for the VSAM files in your COBOL program.

In the FILE SECTION of the DATA DIVISION, code a file description (FD) entry for the file. In the associated record description entry or entries, define the *record-name* and record length. Code the logical size of the records by using the RECORD clause.

Important: You can process VSAM data sets in Enterprise COBOL programs only after you define them by using access method services.

Table 24. VSAM file organization, access mode, and record format

File organization	Sequential access	Random access	Dynamic access	Fixed length	Variable length
VSAM sequential (ESDS)	Yes	No	No	Yes	Yes
VSAM indexed (KSDS)	Yes	Yes	Yes	Yes	Yes
VSAM relative (RRDS)	Yes	Yes	Yes	Yes	Yes

RELATED TASKS

- “Specifying sequential organization for VSAM files”
- “Specifying indexed organization for VSAM files”
- “Specifying relative organization for VSAM files” on page 190
- “Specifying access modes for VSAM files” on page 191
- “Defining record lengths for VSAM files” on page 191
- “Using file status keys” on page 245
- “Using VSAM status codes (VSAM files only)” on page 246
- “Defining VSAM files” on page 203

Specifying sequential organization for VSAM files

Identify VSAM ESDS files in a COBOL program with the ORGANIZATION IS SEQUENTIAL clause. You can access (read or write) records in sequential files only sequentially.

After you place a record in the file, you cannot shorten, lengthen, or delete it. However, you can update (REWRITE) a record if the length does not change. New records are added at the end of the file.

The following example shows typical FILE-CONTROL entries for a VSAM sequential file (ESDS):

```
SELECT S-FILE
  ASSIGN TO SEQUENTIAL-AS-FILE
  ORGANIZATION IS SEQUENTIAL
  ACCESS IS SEQUENTIAL
  FILE STATUS IS FSTAT-CODE VSAM-CODE.
```

RELATED CONCEPTS

- “VSAM files” on page 186

Specifying indexed organization for VSAM files

Identify a VSAM KSDS file in a COBOL program by using the ORGANIZATION IS INDEXED clause. Code a prime key for the record by using the RECORD KEY clause. You can also use alternate keys and an alternate index.

```
RECORD KEY IS data-name
```

In the example above, *data-name* is the name of the prime key field as you define it in the record description entry in the DATA DIVISION. The prime key data item can be class alphabetic, alphanumeric, DBCS, numeric, or national. If it has USAGE NATIONAL, the prime key can be category national, or can be a national-edited, numeric-edited, national decimal, or national floating-point data item. The collation of record keys is based on the binary value of the keys regardless of the class or category of the keys.

The following example shows the statements for a VSAM indexed file (KSDS) that is accessed dynamically. In addition to the primary key, COMMUTER-NO, an alternate key, LOCATION-NO, is specified:

```
SELECT I-FILE
      ASSIGN TO INDEXED-FILE
      ORGANIZATION IS INDEXED
      ACCESS IS DYNAMIC
      RECORD KEY IS IFILE-RECORD-KEY
      ALTERNATE RECORD KEY IS IFILE-ALTREC-KEY
      FILE STATUS IS FSTAT-CODE VSAM-CODE.
```

RELATED CONCEPTS

“VSAM files” on page 186

RELATED TASKS

“Using alternate keys”

“Using an alternate index”

RELATED REFERENCES

RECORD KEY clause (*Enterprise COBOL Language Reference*)

Classes and categories of data (*Enterprise COBOL Language Reference*)

Using alternate keys

In addition to the primary key, you can code one or more alternate keys for a VSAM KSDS file. By using alternate keys, you can access an indexed file to read records in some sequence other than the prime-key sequence.

Alternate keys do not need to be unique. More than one record could be accessed if alternate keys are coded to allow duplicates. For example, you could access the file through employee department rather than through employee number.

You define the alternate key in your COBOL program with the ALTERNATE RECORD KEY clause:

```
ALTERNATE RECORD KEY IS data-name
```

In the example above, *data-name* is the name of the alternate key field as you define it in the record description entry in the DATA DIVISION. Alternate key data items, like prime key data items, can be class alphabetic, alphanumeric, DBCS, numeric, or national. The collation of alternate keys is based on the binary value of the keys regardless of the class or category of the keys.

Using an alternate index

To use an alternate index for a VSAM KSDS file, you need to define a data set called the *alternate index (AIX)* by using access method services.

The AIX contains one record for each value of a given alternate key. The records are in sequential order by alternate-key value. Each record contains the corresponding primary keys of all records in the associated indexed files that contain the alternate-key value.

RELATED TASKS

“Creating alternate indexes” on page 204

Specifying relative organization for VSAM files

Identify VSAM RRDS files in a COBOL program by using the ORGANIZATION IS RELATIVE clause. Use the RELATIVE KEY IS clause to associate each logical record with its relative record number.

The following example shows a relative-record data set (RRDS) that is accessed randomly by the value in the relative key:

```
SELECT R-FILE
  ASSIGN TO RELATIVE-FILE
  ORGANIZATION IS RELATIVE
  ACCESS IS RANDOM
  RELATIVE KEY IS RFILE-RELATIVE-KEY
  FILE STATUS IS FSTAT-CODE VSAM-CODE.
```

You can use a randomizing routine to associate a key value in each record with the relative record number for that record. Although there are many techniques to convert a record key to a relative record number, the most commonly used is the division/remainder technique. With this technique, you divide the key by a value equal to the number of slots in the data set to produce a quotient and remainder. When you add one to the remainder, the result is a valid relative record number.

Alternate indexes are not supported for VSAM RRDS.

RELATED CONCEPTS

“VSAM files” on page 186

“Fixed-length and variable-length RRDS”

RELATED TASKS

“Using variable-length RRDS”

“Defining VSAM files” on page 203

Fixed-length and variable-length RRDS

In an RRDS that has fixed-length records, each record occupies one slot. You store and retrieve records according to the relative record number of the slot. A variable-length RRDS does not have slots; instead, the free space that you define allows for more efficient record insertions.

When you load an RRDS that has fixed-length records, you have the option of skipping over slots and leaving them empty. When you load an RRDS that has variable-length records, you can skip over relative record numbers.

Using variable-length RRDS

To use relative-record data sets (RRDS) that have variable-length records, you must use VSAM variable-length RRDS support.

Do these steps:

1. Define the file with the ORGANIZATION IS RELATIVE clause.
2. Use FD entries to describe the records with variable-length sizes.
3. Use the NOSIMVRD runtime option.
4. Define the VSAM file through access-method services as an RRDS.

RELATED TASKS

“Defining VSAM files” on page 203

RELATED REFERENCES

z/OS DFSMS: Access Method Services for Catalogs

Specifying access modes for VSAM files

You can access records in VSAM sequential files only sequentially. You can access records in VSAM indexed and relative files in three ways: sequentially, randomly, or dynamically.

For sequential access, code `ACCESS IS SEQUENTIAL` in the `FILE-CONTROL` entry. Records in indexed files are then accessed in the order of the key field selected (either primary or alternate). Records in relative files are accessed in the order of the relative record numbers.

For random access, code `ACCESS IS RANDOM` in the `FILE-CONTROL` entry. Records in indexed files are then accessed according to the value you place in a key field. Records in relative files are accessed according to the value you place in the relative key.

For dynamic access, code `ACCESS IS DYNAMIC` in the `FILE-CONTROL` entry. Dynamic access is a mixed sequential-random access in the same program. Using dynamic access, you can write one program to perform both sequential and random processing, accessing some records in sequential order and others by their keys.

“Example: using dynamic access with VSAM files”

RELATED TASKS

“Reading records from a VSAM file” on page 198

Example: using dynamic access with VSAM files

Suppose that you have an indexed file of employee records, and the employee's hourly wage forms the record key.

If your program processes those employees who earn between \$15.00 and \$20.00 per hour and those who earn \$25.00 per hour and above, using dynamic access of VSAM files, the program would:

1. Retrieve the first record randomly (with a random-retrieval `READ`) based on the key of 1500.
2. Read sequentially (using `READ NEXT`) until the salary field exceeds 2000.
3. Retrieve the next record randomly, based on a key of 2500.
4. Read sequentially until the end of the file.

RELATED TASKS

“Reading records from a VSAM file” on page 198

Defining record lengths for VSAM files

You can define VSAM records to be fixed or variable in length. COBOL determines the record format from the `RECORD` clause and the record descriptions that are associated with the `FD` entry for a file.

Because the concept of blocking has no meaning for VSAM files, you can omit the BLOCK CONTAINS clause. The clause is syntax-checked, but it has no effect on how the program runs.

RELATED TASKS

“Defining fixed-length records”
 “Defining variable-length records”
Enterprise COBOL Migration Guide

RELATED REFERENCES

“FILE SECTION entries” on page 12

Defining fixed-length records

To define VSAM records as fixed length, use one of these coding options.

Table 25. Definition of VSAM fixed-length records

RECORD clause	Clause format	Record length	Comments
Code RECORD CONTAINS <i>integer</i> .	1	Fixed in size with a length of <i>integer-3</i> bytes	The lengths of the level-01 record description entries associated with the file do not matter.
Omit the RECORD clause, but code all level-01 records that are associated with the file as the same size; and code none with an OCCURS DEPENDING ON clause.		The fixed size that you coded	

RELATED REFERENCES

RECORD clause (*Enterprise COBOL Language Reference*)

Defining variable-length records

To define VSAM records as variable length, use one of these coding options.

Table 26. Definition of VSAM variable-length records

RECORD clause	Clause format	Maximum record length	Comments
Code RECORD IS VARYING FROM <i>integer-6</i> TO <i>integer-7</i> .	3	<i>integer-7</i> bytes	The lengths of the level-01 record description entries associated with the file do not matter.
Code RECORD IS VARYING.	3	Size of the largest level-01 record description entry associated with the file	The compiler determines the maximum record length.
Code RECORD CONTAINS <i>integer-4</i> TO <i>integer-5</i> .	2	<i>integer-5</i> bytes	The minimum record length is <i>integer-4</i> bytes.

Table 26. Definition of VSAM variable-length records (continued)

RECORD clause	Clause format	Maximum record length	Comments
Omit the RECORD clause, but code multiple level-01 records that are associated with the file and are of different sizes or contain an OCCURS DEPENDING ON clause.		Size of the largest level-01 record description entry associated with the file	The compiler determines the maximum record length.

When you specify a READ INTO statement for a format-V file, the record size that is read for that file is used in the MOVE statement generated by the compiler. Consequently, you might not get the result you expect if the record read in does not correspond to the level-01 record description. All other rules of the MOVE statement apply. For example, when you specify a MOVE statement for a format-V record read in by the READ statement, the size of the record corresponds to its level-01 record description.

RELATED REFERENCES

RECORD clause (*Enterprise COBOL Language Reference*)

Coding input and output statements for VSAM files

Use the COBOL statements shown below to process VSAM files.

OPEN To connect the VSAM data set to your COBOL program for processing.

WRITE To add records to a file or load a file.

START To establish the current location in the cluster for a READ NEXT statement.

START does not retrieve a record; it only sets the current record pointer.

READ and READ NEXT

To retrieve records from a file.

REWRITE

To update records.

DELETE To logically remove records from indexed and relative files only.

CLOSE To disconnect the VSAM data set from your program.

All of the following factors determine which input and output statements you can use for a given VSAM data set:

- Access mode (sequential, random, or dynamic)
- File organization (ESDS, KSDS, or RRDS)
- Mode of OPEN statement (INPUT, OUTPUT, I-0, or EXTEND)

The following table shows the possible combinations of statements and open modes for sequential files (ESDS). The X indicates that you can use a statement with the open mode shown at the top of the column.

Table 27. I/O statements for VSAM sequential files

Access mode	COBOL statement	OPEN INPUT	OPEN OUTPUT	OPEN I-O	OPEN EXTEND
Sequential	OPEN	X	X	X	X
	WRITE		X		X
	START				
	READ	X		X	
	REWRITE			X	
	DELETE				
	CLOSE	X	X	X	X

The following table shows the possible combinations of statements and open modes that you can use with indexed (KSDS) files and relative (RRDS) files. The X indicates that you can use the statement with the open mode shown at the top of the column.

Table 28. I/O statements for VSAM relative and indexed files

Access mode	COBOL statement	OPEN INPUT	OPEN OUTPUT	OPEN I-O	OPEN EXTEND
Sequential	OPEN	X	X	X	X
	WRITE		X		X
	START	X		X	
	READ	X		X	
	REWRITE			X	
	DELETE			X	
	CLOSE	X	X	X	X
Random	OPEN	X	X	X	
	WRITE		X	X	
	START				
	READ	X		X	
	REWRITE			X	
	DELETE			X	
	CLOSE	X	X	X	
Dynamic	OPEN	X	X	X	
	WRITE		X	X	
	START	X		X	
	READ	X		X	
	REWRITE			X	
	DELETE			X	
	CLOSE	X	X	X	

The fields that you code in the FILE STATUS clause are updated by VSAM after each input-output statement to indicate the success or failure of the operation.

RELATED CONCEPTS

“File position indicator”

RELATED TASKS

“Opening a file (ESDS, KSDS, or RRDS)”
“Reading records from a VSAM file” on page 198
“Updating records in a VSAM file” on page 199
“Adding records to a VSAM file” on page 199
“Replacing records in a VSAM file” on page 200
“Deleting records from a VSAM file” on page 200
“Closing VSAM files” on page 200

RELATED REFERENCES

File status key (*Enterprise COBOL Language Reference*)

File position indicator

The file position indicator marks the next record to be accessed for sequential COBOL requests. You do not set the file position indicator in your program. It is set by successful OPEN, START, READ, and READ NEXT statements.

Subsequent READ or READ NEXT requests use the established file position indicator location and update it.

The file position indicator is not used or affected by the output statements WRITE, REWRITE, or DELETE. The file position indicator has no meaning for random processing.

RELATED TASKS

“Reading records from a VSAM file” on page 198

Opening a file (ESDS, KSDS, or RRDS)

Before you can use WRITE, START, READ, REWRITE, or DELETE statements to process records in a file, you must first open the file with an OPEN statement.

Whether a file is available or optional affects OPEN processing, file creation, and the resulting file status key. For example, if you open in EXTEND, I-0, or INPUT mode a nonexistent non-OPTIONAL file, the result is an OPEN error, and file status 35 is returned. If the file is OPTIONAL, however, the same OPEN statement returns file status 05, and, for open modes EXTEND and I-0, creates the file.

An OPEN operation works successfully only if you set fixed file attributes in the DD statement or data-set label for a file, and specify consistent attributes for the file in the SELECT clause and FD entries of your COBOL program. Mismatches in the following items result in a file status key 39 and the failure of the OPEN statement:

- Attributes for file organization (sequential, relative, or indexed)
- Prime record key
- Alternate record keys
- Maximum record size
- Record type (fixed or variable)

How you code the OPEN statement for a VSAM file depends on whether the file is empty (a file that has never contained records) or loaded. For either type of file, your program should check the file status key after each OPEN statement.

RELATED TASKS

“Opening an empty file”

“Opening a loaded file (a file with records)” on page 197

RELATED REFERENCES

“Statements to load records into a VSAM file” on page 197

Opening an empty file

To open a file that has never contained records (an empty file), use a form of the OPEN statement.

Depending on the type of file that you are opening, use one of the following statements:

- OPEN OUTPUT for ESDS files.
- OPEN OUTPUT or OPEN EXTEND for KSDS and RRDS files. (Either coding has the same effect.) If you coded the file for random or dynamic access and the file is optional, you can use OPEN I-0.

Optional files are files that are not necessarily available each time a program is run. You can define files opened in INPUT, I-0, or OUTPUT mode as optional by defining them with the SELECT OPTIONAL clause in the FILE-CONTROL paragraph.

Initially loading a file sequentially: Initially loading a file means writing records into the file for the first time. Doing so is not the same as writing records into a file from which all previous records have been deleted. To initially load a VSAM file:

1. Open the file.
2. Use sequential processing (ACCESS IS SEQUENTIAL). (Sequential processing is faster than random or dynamic processing.)
3. Use WRITE to add a record to the file.

Using OPEN OUTPUT to load a VSAM file significantly improves the performance of your program. Using OPEN I-0 or OPEN EXTEND has a negative effect on the performance of your program.

When you load VSAM indexed files sequentially, you optimize both loading performance and subsequent processing performance, because sequential processing maintains user-defined free space. Future insertions will be more efficient.

With ACCESS IS SEQUENTIAL, you must write the records in ascending RECORD KEY order.

When you load VSAM relative files sequentially, the records are placed in the file in the ascending order of relative record numbers.

Initially loading a file randomly or dynamically: You can use random or dynamic processing to load a file, but they are not as efficient as sequential processing. Because VSAM does not support random or dynamic processing, COBOL has to perform some extra processing to enable you to use ACCESS IS RANDOM or ACCESS IS DYNAMIC with OPEN OUTPUT or OPEN I-0. These steps prepare the file for use and give it the status of a loaded file because it has been used at least once.

In addition to extra overhead for preparing files for use, random processing does not consider any user-defined free space. As a result, any future insertions might be inefficient. Sequential processing maintains user-defined free space.

When you are loading an extended-format VSAM data set, file status 30 will occur for the OPEN if z/OS DFSMS system-managed buffering sets the buffering to local shared resources (LSR). To successfully load the VSAM data set in this case, specify ACCBIAS=USER in the DD AMP parameter for the VSAM data set to bypass system-managed buffering.

Loading a VSAM data set with access method services: You can load or update a VSAM data set by using the access method services REPRO command. Use REPRO whenever possible.

RELATED TASKS

“Opening a loaded file (a file with records)”

RELATED REFERENCES

“Statements to load records into a VSAM file”

z/OS DFSMS: Access Method Services for Catalogs (REPRO)

Statements to load records into a VSAM file

Use the statements shown below to load records into a VSAM file.

Table 29. Statements to load records into a VSAM file

Division	ESDS	KSDS	RRDS
ENVIRONMENT DIVISION	SELECT ASSIGN FILE STATUS PASSWORD ACCESS MODE	SELECT ASSIGN ORGANIZATION IS INDEXED RECORD KEY ALTERNATE RECORD KEY FILE STATUS PASSWORD ACCESS MODE	SELECT ASSIGN ORGANIZATION IS RELATIVE RELATIVE KEY FILE STATUS PASSWORD ACCESS MODE
DATA DIVISION	FD entry	FD entry	FD entry
PROCEDURE DIVISION	OPEN OUTPUT OPEN EXTEND WRITE CLOSE	OPEN OUTPUT OPEN EXTEND WRITE CLOSE	OPEN OUTPUT OPEN EXTEND WRITE CLOSE

RELATED TASKS

“Opening an empty file” on page 196

“Updating records in a VSAM file” on page 199

Opening a loaded file (a file with records)

To open a file that already contains records, use OPEN INPUT, OPEN I-0, or OPEN EXTEND.

If you open a VSAM entry-sequenced or relative-record file as EXTEND, the added records are placed after the last existing records in the file.

If you open a VSAM key-sequenced file as EXTEND, each record you add must have a record key higher than the highest record in the file.

RELATED TASKS

“Opening an empty file” on page 196

“Working with VSAM data sets under z/OS and z/OS UNIX” on page 202

RELATED REFERENCES

“Statements to load records into a VSAM file” on page 197

z/OS DFSMS: Access Method Services for Catalogs

Reading records from a VSAM file

Use the READ statement to retrieve (READ) records from a file. To read a record, you must have opened the file INPUT or I-0. Your program should check the file status key after each READ.

You can retrieve records in VSAM sequential files only in the sequence in which they were written.

You can retrieve records in VSAM indexed and relative record files in any of the following ways:

Sequentially

According to the ascending order of the key you are using, the RECORD KEY or the ALTERNATE RECORD KEY, beginning at the current position of the file position indicator for indexed files, or according to ascending relative record locations for relative files

Randomly

In any order, depending on how you set the RECORD KEY or ALTERNATE RECORD KEY or the RELATIVE KEY before your READ request

Dynamically

Mixed sequential and random

With dynamic access, you can switch between reading a specific record directly and reading records sequentially, by using READ NEXT for sequential retrieval and READ for random retrieval (by key).

When you want to read sequentially, beginning at a specific record, use START before the READ NEXT statement to set the file position indicator to point to a particular record. When you code START followed by READ NEXT, the next record is read and the file position indicator is reset to the next record. You can move the file position indicator randomly by using START, but all reading is done sequentially from that point.

```
START file-name KEY IS EQUAL TO ALTERNATE-RECORD-KEY
```

When a direct READ is performed for a VSAM indexed file, based on an alternate index for which duplicates exist, only the first record in the data set (base cluster) with that alternate key value is retrieved. You need a series of READ NEXT statements to retrieve each of the data set records with the same alternate key. A file status code of 02 is returned if there are more records with the same alternate key value to be read; a code of 00 is returned when the last record with that key value has been read.

RELATED CONCEPTS

“File position indicator” on page 195

RELATED TASKS

“Specifying access modes for VSAM files” on page 191

Updating records in a VSAM file

To update a VSAM file, use these PROCEDURE DIVISION statements.

Table 30. Statements to update records in a VSAM file

Access method	ESDS	KSDS	RRDS
ACCESS IS SEQUENTIAL	OPEN EXTEND WRITE CLOSE or OPEN I-O READ REWRITE CLOSE	OPEN EXTEND WRITE CLOSE or OPEN I-O READ REWRITE DELETE CLOSE	OPEN EXTEND WRITE CLOSE or OPEN I-O READ REWRITE DELETE CLOSE
ACCESS IS RANDOM	Not applicable	OPEN I-O READ WRITE REWRITE DELETE CLOSE	OPEN I-O READ WRITE REWRITE DELETE CLOSE
ACCESS IS DYNAMIC (sequential processing)	Not applicable	OPEN I-O READ NEXT WRITE REWRITE START DELETE CLOSE	OPEN I-O READ NEXT WRITE REWRITE START DELETE CLOSE
ACCESS IS DYNAMIC (random processing)	Not applicable	OPEN I-O READ WRITE REWRITE DELETE CLOSE	OPEN I-O READ WRITE REWRITE DELETE CLOSE

RELATED REFERENCES

“Statements to load records into a VSAM file” on page 197

Adding records to a VSAM file

Use the COBOL WRITE statement to add a record to a file without replacing any existing records. The record to be added must not be larger than the maximum record size that you set when you defined the file. Your program should check the file status key after each WRITE statement.

Adding records sequentially: Use ACCESS IS SEQUENTIAL and code the WRITE statement to add records sequentially to the end of a VSAM file that has been opened with either OUTPUT or EXTEND.

Sequential files are always written sequentially.

For indexed files, you must write new records in ascending key sequence. If you open the file EXTEND, the record keys of the records to be added must be higher than the highest primary record key on the file when you opened the file.

For relative files, the records must be in sequence. If you include a RELATIVE KEY data item in the SELECT clause, the relative record number of the record to be written is placed in that data item.

Adding records randomly or dynamically: When you write records to an indexed data set and ACCESS IS RANDOM or ACCESS IS DYNAMIC, you can write the records in any order.

Replacing records in a VSAM file

To replace a record in a VSAM file, use REWRITE on a file that you opened as I-0. If the file was not opened as I-0, the record is not rewritten and the status key is set to 49. Check the file status key after each REWRITE statement.

For sequential files, the length of the replacement record must be the same as the length of the original record. For indexed files or variable-length relative files, you can change the length of the record you replace.

To replace a record randomly or dynamically, you do not have to first READ the record. Instead, locate the record you want to replace as follows:

- For indexed files, move the record key to the RECORD KEY data item, and then issue the REWRITE.
- For relative files, move the relative record number to the RELATIVE KEY data item, and then issue the REWRITE.

Deleting records from a VSAM file

To remove an existing record from an indexed or relative file, open the file I-0 and use the DELETE statement. You cannot use DELETE on a sequential file.

When you use ACCESS IS SEQUENTIAL or the file contains spanned records, your program must first read the record to be deleted. The DELETE then removes the record that was read. If the DELETE is not preceded by a successful READ, the deletion is not done and the status key value is set to 92.

When you use ACCESS IS RANDOM or ACCESS IS DYNAMIC, your program does not have to first read the record to be deleted. To delete a record, move the key of the record to be deleted to the RECORD KEY data item, and then issue the DELETE. Your program should check the file status key after each DELETE statement.

Closing VSAM files

Use the CLOSE statement to disconnect your program from a VSAM file. If you try to close a file that is already closed, you will get a logic error. Check the file status key after each CLOSE statement.

If you do not close a VSAM file, the file is automatically closed for you under the following conditions:

- When the run unit ends normally, all open files defined in any COBOL programs in the run unit are closed.
- When the run unit ends abnormally, if the TRAP(ON) runtime option has been set, all open files defined in any COBOL programs in the run unit are closed.
- When Language Environment condition handling has completed and the application resumes in a routine other than where the condition occurred, open files defined in any COBOL programs in the run unit that might be called again and reentered are closed.

You can change the location where a program resumes after a condition is handled. To make this change, you can, for example, move the resume cursor with the CEEMRCR callable service or use language constructs such as a C longjmp statement.

- When you issue CANCEL for a COBOL subprogram, any open nonexternal files defined in that program are closed.
- When a COBOL subprogram with the INITIAL attribute returns control, any open nonexternal files defined in that program are closed.
- When a thread of a multithreaded application ends, both external and nonexternal files that were opened from within that same thread are closed.

File status key data items in the DATA DIVISION are set when these implicit CLOSE operations are performed, but your EXCEPTION/ERROR declarative is not invoked.

Errors: If you open a VSAM file in a multithreaded application, you must close it from the same thread of execution. Attempting to close the file from a different thread results in a close failure with file-status condition 90.

Handling errors in VSAM files

When an input or output statement operation fails, COBOL does not perform corrective action for you.

All OPEN and CLOSE errors with a VSAM file, whether logical errors in your program or input/output errors on the external storage media, return control to your COBOL program even if you coded no DECLARATIVE and no FILE STATUS clause.

If any other input or output statement operation fails, you choose whether your program will continue running after a less-than-severe error.

COBOL provides these ways for you to intercept and handle certain VSAM input and output errors:

- End-of-file phrase (AT END)
- EXCEPTION/ERROR declarative
- FILE STATUS clause (file status key and VSAM status code)
- INVALID KEY phrase

You should define a status key for each VSAM file that you define in your program. Check the status key value after each input or output request, especially OPEN and CLOSE.

If you do not code a file status key or a declarative, serious VSAM processing errors will cause a message to be issued and a Language Environment condition to be signaled, which will cause an abend if you specify the runtime option ABTERMENC (ABEND).

RELATED TASKS

“Handling errors in input and output operations” on page 241

“Using VSAM status codes (VSAM files only)” on page 246

RELATED REFERENCES

z/OS DFSMS Macro Instructions for Data Sets (VSAM macro return and reason codes)

Protecting VSAM files with a password

Although the preferred security mechanism on a z/OS system is RACF®, Enterprise COBOL also supports using explicit passwords on VSAM files to prevent unauthorized access and update.

To use explicit passwords, code the PASSWORD clause in the FILE-CONTROL paragraph. Use this clause only if the catalog entry for the files includes a read or an update password:

- If the catalog entry includes a read password, you cannot open and access the file in a COBOL program unless you use the PASSWORD clause in the FILE-CONTROL paragraph and describe it in the DATA DIVISION. The *data-name* referred to must contain a valid password when the file is opened.
- If the catalog entry includes an update password, you can open and access it, but not update it, unless you code the PASSWORD clause in the FILE-CONTROL paragraph and describe it in the DATA DIVISION.
- If the catalog entry includes both a read password and an update password, specify the update password to both read and update the file in your program.

If your program only retrieves records and does not update them, you need only the read password. If your program loads files or updates them, you need to specify the update password that was cataloged.

For indexed files, the PASSWORD data item for the RECORD KEY must contain the valid password before the file can be successfully opened.

If you password-protect a VSAM indexed file, you must also password-protect each alternate index in order to be fully password protected. Where you place the PASSWORD clause is important because each alternate index has its own password. The PASSWORD clause must directly follow the key clause to which it applies.

Example: password protection for a VSAM indexed file

The following example shows the COBOL code used for a VSAM indexed file that has password protection.

```
.....  
INPUT-OUTPUT SECTION.  
FILE-CONTROL.  
    SELECT LIBFILE  
    ASSIGN TO PAYMAST  
    ORGANIZATION IS INDEXED  
    RECORD KEY IS EMPL-NUM  
    PASSWORD IS BASE-PASS  
    ALTERNATE RECORD KEY IS EMPL-PHONE  
    PASSWORD IS PATH1-PASS  
  
.....  
WORKING-STORAGE SECTION.  
01 BASE-PASS          PIC X(8) VALUE "25BSREAD".  
01 PATH1-PASS         PIC X(8) VALUE "25ATREAD".
```

Working with VSAM data sets under z/OS and z/OS UNIX

Be aware of special coding considerations for VSAM files under z/OS and z/OS UNIX for access method services (IDCAMS) commands, environment variables, and JCL.

A VSAM file is *available* if all of the following conditions are true:

- You define it using access method services.
- You define it for your program by providing a DD statement, an environment variable, or an ALLOCATE command.
- It has previously contained a record.

A VSAM file is *unavailable* if it has never contained a record, even if you have defined the file.

You always get a return code of zero on completion of the OPEN statement for a VSAM sequential file.

Use the access method services REPRO command to empty a file. Deleting records in this manner resets the high-use relative byte address (RBA) of the file to zero. The file is effectively empty and appears to COBOL as if it never contained a record.

RELATED TASKS

“Defining files to the operating system” on page 8

“Defining VSAM files”

“Creating alternate indexes” on page 204

“Allocating VSAM files” on page 206

“Sharing VSAM files through RLS” on page 207

Defining VSAM files

You can process VSAM entry-sequenced, key-sequenced, and relative-record data sets in Enterprise COBOL only after you define them through access method services (IDCAMS).

A VSAM *cluster* is a logical definition for a VSAM data set and has one or two components:

- The data component of a VSAM cluster contains the data records.
- The index component of a VSAM key-sequenced cluster consists of the index records.

Use the DEFINE CLUSTER access-method services command to define VSAM data sets (clusters). This process includes creating an entry in an integrated catalog without any data transfer. Define the following information about the cluster:

- Name of the entry
- Name of the catalog to contain this definition and its password (can use default name)
- Organization (sequential, indexed, or relative)
- Device and volumes that the data set will occupy
- Space required for the data set
- Record size and control interval sizes (CISIZE)
- Passwords (if any) required for future access

Depending on what kind of data set is in the cluster, also define the following information for each cluster:

- For VSAM indexed data sets (KSDS), specify length and position of the prime key in the records.
- For VSAM fixed-length relative-record data sets (RRDS), specify the record size as greater than or equal to the maximum size COBOL record:

```
DEFINE CLUSTER NUMBERED  
RECORDSIZE(n,n)
```

If you define a data set in this way, all records are padded to the fixed slot size *n*. If you use the RECORD IS VARYING ON *data-name* form of the RECORD clause, a WRITE or REWRITE uses the length specified in DEPENDING ON *data-name* as the length of the record to be transferred by VSAM. This data is then padded to the fixed slot size. READ statements always return the fixed slot size in the DEPENDING ON *data-name*.

- For VSAM variable-length relative-record data sets (RRDS), specify the average size COBOL record expected and the maximum size COBOL record expected:

```
DEFINE CLUSTER NUMBERED  
RECORDSIZE(avg,m)
```

The average size COBOL record expected must be less than the maximum size COBOL record expected.

RELATED TASKS

“Creating alternate indexes”

“Allocating VSAM files” on page 206

“Specifying relative organization for VSAM files” on page 190

RELATED REFERENCES

z/OS DFSMS: Access Method Services for Catalogs

Creating alternate indexes

An alternate index provides access to the records in a data set that uses more than one key. It accesses records in the same way as the prime index key of an indexed data set (KSDS).

When planning to use an alternate index, you must know:

- The type of data set (base cluster) with which the index will be associated
- Whether the keys will be unique or not unique
- Whether the index is to be password protected
- Some of the performance aspects of using alternate indexes

Because an alternate index is, in practice, a VSAM data set that contains pointers to the keys of a VSAM data set, you must define the alternate index and the alternate index path (the entity that establishes the relationship between the alternate index and the prime index). After you define an alternate index, make a catalog entry to establish the relationship (or path) between the alternate index and its base cluster. This path allows you to access the records of the base cluster through the alternate keys.

To use an alternate index, do these steps:

1. Define the alternate index by using the DEFINE ALTERNATEINDEX command. In it, specify these items:
 - Name of the alternate index
 - Name of its related VSAM indexed data set
 - Location in the record of any alternate indexes and whether they are unique
 - Whether alternate indexes are to be updated when the data set is changed
 - Name of the catalog to contain this definition and its password (can use default name)

In your COBOL program, the alternate index is identified solely by the ALTERNATE RECORD KEY clause in the FILE-CONTROL paragraph. The ALTERNATE RECORD KEY definitions must match the definitions in the catalog entry. Any password entries that you cataloged should be coded directly after the ALTERNATE RECORD KEY phrase.

2. Relate the alternate index to the base cluster (the data set to which the alternate index gives you access) by using the DEFINE PATH command. In it, specify these items:
 - Name of the path
 - Alternate index to which the path is related
 - Name of the catalog that contains the alternate index

The base cluster and alternate index are described by entries in the same catalog.

3. Load the VSAM indexed data set.
4. Build the alternate index by using (typically) the BLDINDEX command. Identify the input file as the indexed data set (base cluster) and the output file as the alternate index or its path. BLDINDEX reads all the records in the VSAM indexed data set (or base cluster) and extracts the data needed to build the alternate index.

Alternatively, you can use the runtime option AIXBLD to build the alternate index at run time. However, this option might adversely affect performance.

“Example: entries for alternate indexes”

RELATED TASKS

“Using an alternate index” on page 189

RELATED REFERENCES

Language Environment Programming Reference (AIXBLD (COBOL only))

Example: entries for alternate indexes

The following example maps the relationships between the COBOL FILE-CONTROL entry and the DD statements or environment variables for a VSAM indexed file that has two alternate indexes.

Using JCL:

```
//MASTERA DD DSN=clustname,DISP=OLD (1)
//MASTERA1 DD DSN=path1,DISP=OLD (2)
//MASTERA2 DD DSN=path2,DISP=OLD (3)
```

Using environment variables:

```
export MASTERA=DSN(clustname),OLD (1)
export MASTERA=DSN(path1),OLD (2)
export MASTERA=DSN(path2),OLD (3)
```

```
. . .
FILE-CONTROL.
  SELECT MASTER-FILE ASSIGN TO MASTERA (4)
  RECORD KEY IS EM-NAME
  PASSWORD IS PW-BASE (5)
  ALTERNATE RECORD KEY IS EM-PHONE (6)
  PASSWORD IS PW-PATH1
  ALTERNATE RECORD KEY IS EM-CITY (7)
  PASSWORD IS PW-PATH2.
```

(1) The base cluster name is *clustname*.

(2) The name of the first alternate index path is *path1*.

- (3) The name of the second alternate index path is *path2*.
- (4) The ddname or environment variable name for the base cluster is specified with the ASSIGN clause.
- (5) Passwords immediately follow their indexes.
- (6) The key EM-PHONE relates to the first alternate index.
- (7) The key EM-CITY relates to the second alternate index.

RELATED TASKS

“Creating alternate indexes” on page 204

Allocating VSAM files

You must predefine and catalog all VSAM data sets through the access method services DEFINE command. Most of the information about a VSAM data set is in the catalog, so you need to specify only minimal DD or environment variable information.

Allocation of VSAM files (indexed, relative, and sequential) follows the general rules for the allocation of COBOL files.

When you use an environment variable to allocate a VSAM file, the variable name must be in uppercase. Usually the input and data buffers are the only variables that you are concerned about. You must specify these options in the order shown, but no others:

1. DSN(*dsname*), where *dsname* is the name of the base cluster
2. OLD or SHR

The basic DD statement that you need for VSAM files and the corresponding export command are these:

```
//ddname DD DSN=dsname,DISP=SHR,AMP=AMORG
export evname="DSN(dsname),SHR"
```

In either case, *dsname* must be the same as the name used in the access method services DEFINE CLUSTER or DEFINE PATH command. DISP must be OLD or SHR because the data set is already cataloged. If you specify MOD when using JCL, the data set is treated as OLD.

AMP is a VSAM JCL parameter that supplements the information that the program supplies about the data set. AMP takes effect when your program opens the VSAM file. Any information that you set through the AMP parameter takes precedence over the information that is in the catalog or that the program supplies. The AMP parameter is required only under the following circumstances:

- You use a dummy VSAM data set. For example,

```
//ddname DD DUMMY,AMP=AMORG
```

- You request additional index or data buffers. For example,

```
//ddname DD DSN=VSAM.dsname,DISP=SHR,
// AMP=('BUFNI=4,BUFND=8')
```

You cannot specify AMP if you allocate a VSAM data set with an environment variable.

For a VSAM base cluster, specify the same system-name (ddname or environment variable name) that you specify in the ASSIGN clause after the SELECT clause.

When you use alternate indexes in your COBOL program, you must specify not only a system-name (using a DD statement or environment variable) for the base cluster, but also a system-name for each alternate index path. No language mechanism exists to explicitly declare system-names for alternate index paths within the program. Therefore, you must adhere to the following guidelines for forming the system-name (ddname or environment variable name) for each alternate index path:

- Concatenate the base cluster name with an integer.
- Begin with 1 for the path associated with the first alternate record defined for the file in your program (ALTERNATE RECORD KEY clause of the FILE-CONTROL paragraph).
- Increment by 1 for the path associated with each successive alternate record definition for that file.

For example, if the system-name of a base cluster is ABCD, the system-name for the first alternate index path defined for the file in your program is ABCD1, the system-name for the second alternate index path is ABCD2, and so on.

If the length of the base cluster system-name together with the sequence number exceeds eight characters, the base cluster portion of the system-name is truncated on the right to reduce the concatenated result to eight characters. For example, if the system-name of a base cluster is ABCDEFGH, the system name of the first alternate index path is ABCDEFG1, the tenth is ABCDEF10, and so on.

RELATED TASKS

“Allocating files” on page 157

RELATED REFERENCES

MVS Program Management: User's Guide and Reference

Sharing VSAM files through RLS

By using the VSAM JCL parameter RLS, you can specify record-level sharing with VSAM. Specifying RLS is the only way to request the RLS mode when running COBOL programs.

Use RLS=CR when consistent read protocols are required, and RLS=NRI when no read integrity protocols are required. You cannot specify RLS if you allocate your VSAM data set with an environment variable

RELATED TASKS

“Preventing update problems with VSAM files in RLS mode”

“Handling errors in VSAM files in RLS mode” on page 208

RELATED REFERENCES

“Restrictions when using RLS” on page 208

Preventing update problems with VSAM files in RLS mode

When you open a VSAM data set in RLS mode for I-O (updates), the first READ causes an exclusive lock of the record regardless of the value of RLS (RLS=CR or RLS=NRI) that you specify.

If the COBOL file is defined as ACCESS RANDOM, VSAM releases the exclusive lock on the record after a WRITE or REWRITE statement is executed or a READ statement is executed for another record. When a WRITE or REWRITE is done, VSAM writes the record immediately.

However, if the COBOL file is defined as ACCESS DYNAMIC, VSAM does not release the exclusive lock on the record after a WRITE or REWRITE statement, nor after a READ statement, unless the I-O statement causes VSAM to move to another control interval (CI). As a result, if a WRITE or REWRITE was done, VSAM does not write the record until processing is moved to another CI and the lock is released. When you use ACCESS DYNAMIC, one way to cause the record to be written immediately, to release the exclusive lock immediately, or both, is to define the VSAM data set to allow only one record per CI.

Specifying RLS=CR locks a record and prevents an update to it until another READ is requested for another record. While a lock on the record being read is in effect, other users can request a READ for the same record, but they cannot update the record until the read lock is released. When you specify RLS=NRI, no lock will be in effect when a READ for input is executed. Another user might update the record.

The locking rules for RLS=CR can cause the application to wait for availability of a record lock. This wait might slow down the READ for input. You might need to modify your application logic to use RLS=CR. Do not use the RLS parameter for batch jobs that update nonrecoverable spheres until you are sure that the application functions correctly in a multiple-updater environment.

When you open a VSAM data set in RLS mode for INPUT or I-O processing, it is good to issue an OPEN or START *immediately* before a READ. If there is a delay between the OPEN or START and the READ, another user might add records before the record on which the application is positioned after the OPEN or START. The COBOL run time points explicitly to the beginning of the VSAM data set at the time when OPEN was requested, but another user might add records that would alter the true beginning of the VSAM data set if the READ is delayed.

Restrictions when using RLS

When you use RLS mode, several restrictions apply to VSAM cluster attributes and to runtime options.

Be aware of these restrictions:

- The VSAM cluster attributes KEYRANGE and IMBED are not supported when you open a VSAM file.
- The VSAM cluster attribute REPLICATE is not recommended because the benefits are negated by the system-wide buffer pool and potentially large CF cache structure in the storage hierarchy.
- The AIXBLD runtime option is not supported when you open a VSAM file because VSAM does not allow an empty path to be opened. If you need the AIXBLD runtime option to build the alternate index data set, open the VSAM data set in non-RLS mode.
- The SIMVRD runtime option is not supported for VSAM files.
- Temporary data sets are not allowed.

Handling errors in VSAM files in RLS mode

If your application accesses a VSAM data set in RLS mode, be sure to check the file status and VSAM feedback codes after *each* request.

If your application encounters "SMSVSAM server not available" while processing input or output, explicitly close the VSAM file before you try to open it again. VSAM generates return code 16 for such failures, and there is no feedback code. You can have COBOL programs check the first 2 bytes of the second file status

area for VSAM return code 16. The COBOL run time generates message IGZ0205W and automatically closes the file if the error occurs during OPEN processing.

All other RLS mode errors return a VSAM return code of 4, 8, or 12.

RELATED TASKS

“Using VSAM status codes (VSAM files only)” on page 246

Allocation of record areas for VSAM files

For reentrant COBOL programs, the record areas for VSAM files are allocated above the 16 MB line by default.

If you specify the DATA(24) compiler option, the VSAM record areas and other dynamic storage areas are allocated in storage below 16 MB.

Programs that pass data in VSAM file records as CALL...USING parameters to AMODE 24 subprograms are impacted. You can recompile such programs with the DATA(24) compiler option, or use the Language Environment HEAP runtime option, to ensure that the records are addressable by the AMODE 24 programs.

Improving VSAM performance

Your system programmer is most likely responsible for tuning the performance of COBOL and VSAM. As an application programmer, you can control the aspects of VSAM that are listed in the following table.

Table 31. Methods for improving VSAM performance

Aspect of VSAM	What you can do	Rationale and comments
Invoking access methods service	Build your alternate indexes in advance, using IDCAMS.	
Buffering	For sequential access, request more data buffers; for random access, request more index buffers. Specify both BUFND and BUFNI if ACCESS IS DYNAMIC. Avoid coding additional buffers unless your application will run interactively; then code buffers only when response-time problems arise that might be caused by delays in input and output.	The default is one index (BUFNI) and two data buffers (BUFND).

Table 31. Methods for improving VSAM performance (continued)

Aspect of VSAM	What you can do	Rationale and comments
Loading records, using access methods services	<p>Use the access methods service REPRO command when:</p> <ul style="list-style-type: none"> The target indexed data set already contains records. The input sequential data set contains records to be updated or inserted into the indexed data set. <p>If you use a COBOL program to load the file, use OPEN OUTPUT and ACCESS SEQUENTIAL.</p>	The REPRO command can update an indexed data set as fast or faster than any COBOL program under these conditions.
File access modes	For best performance, access records sequentially.	Dynamic access is less efficient than sequential access, but more efficient than random access. Random access results in increased EXCPs because VSAM must access the index for each request.
Key design	Design the key in the records so that the high-order portion is relatively constant and the low-order portion changes often.	This method compresses the key best.
Multiple alternate indexes	Avoid using multiple alternate indexes.	Updates must be applied through the primary paths and are reflected through multiple alternate paths, perhaps slowing performance.
Relative file organization	Use VSAM fixed-length relative data sets rather than VSAM variable-length relative data sets.	Although not as space efficient, VSAM fixed-length relative data sets are more run time efficient than VSAM variable-length relative data sets.
Control interval sizes (CISZ)	<p>Provide your system programmer with information about the data access and future growth of your VSAM data sets. From this information, your system programmer can determine the best control interval size (CISZ) and FREESPACE size (FSPC).</p> <p>Choose proper values for CISZ and FSPC to minimize control area (CA) splits. You can diagnose the current number of CA splits by issuing the LISTCAT ALL command on the cluster, and then compress (using EXPORT, IMPORT, or REPRO) the cluster to omit all CA splits periodically.</p>	<p>VSAM calculates CISZ to best fit the direct-access storage device (DASD) usage algorithm, which might not, however, be efficient for your application.</p> <p>An average CISZ of 4K is suitable for most applications. A smaller CISZ means faster retrieval for random processing at the expense of inserts (that is, more CISZ splits and therefore more space in the data set). A larger CISZ results in the transfer of more data across the channel for each READ. This is more efficient for sequential processing, similar to a large OS BLKSIZE.</p> <p>Many control area (CA) splits are unfavorable for VSAM performance. The FREESPACE value can affect CA splits, depending on how the file is used.</p>

RELATED TASKS

“Specifying access modes for VSAM files” on page 191

z/OS DFSMS: Using Data Sets (Building a resource pool, Selecting the optimal percentage of free space)

RELATED REFERENCES

z/OS DFSMS: Access Method Services for Catalogs

Extended addressability support

You can access VSAM data sets that are defined with the extended addressability attribute, use those VSAM data sets in COBOL programs without COBOL source changes, and maintain compatibility with previous versions of COBOL.

With extended addressability support, you can define larger VSAM data sets outside of COBOL. The 4 GB VSAM architectural limit for data set size imposed by using the 4-byte field for the relative byte address (RBA) is eliminated.

To use the extended addressability, the VSAM data set must be Storage Management Subsystem (SMS)-managed and be defined as extended format. The size limit for a VSAM data set is determined in either of the following ways:

- Control Interval (CI) size multiplied by 4 GB
- Volume size multiplied by 59

For example, a 4 KB CI size yields a maximum data set size of 16 TB, and a 32 KB CI size yields a maximum data set size of 128 TB. A 4 KB CI size is preferred by many applications for performance reasons. For extended-format data sets that grow beyond 4 GB, the processing time does not increase.

Extended addressability is also supported for programs compiled with earlier versions: VS COBOL II programs compiled with RES and any later compilers.

Extended addressability and extended format are not the same concept. Extended format is a prerequisite for extended addressability. Extended format is a technique that affects the way of storing count key data (CKD) in a 3390/3380 logical track. Extended format implements data striping and increases the performance and the reliability of an I/O operation. If a data set is allocated as an extended-format data set, 32 bytes are added to each physical block.

Restriction: Extended addressability was introduced for KSDS data sets in DFSMS/MVS V1.3. Since DFSMS/MVS V1.4, extended addressability is supported in record level sharing (RLS). With DFSMS/MVS V1.5, support for extended addressability is extended to all other VSAM record organizations.

RELATED TASKS

z/OS DFSMS: Using Data Sets

Chapter 11. Processing line-sequential files

Line-sequential files reside in the z/OS UNIX file system and can contain both printable characters and control characters as data. Each record ends with an EBCDIC newline character (X'15'), which is not included in the record length.

Because line-sequential files are sequential, records are placed one after another according to entry order. Your program can process these files only sequentially, retrieving (with the READ statement) records in the same order as they are in the file. A new record is placed after the preceding record.

To process line-sequential files in a program, code COBOL language statements that:

- Identify and describe the files in the ENVIRONMENT DIVISION and the DATA DIVISION
- Process the records in the files in the PROCEDURE DIVISION

After you have created a record, you cannot change its length or its position in the file, and you cannot delete it.

RELATED TASKS

“Defining line-sequential files and records in COBOL”

“Allocating line-sequential files” on page 214

“Coding input-output statements for line-sequential files” on page 215

“Handling errors in line-sequential files” on page 218

UNIX System Services User's Guide

Defining line-sequential files and records in COBOL

Use the FILE-CONTROL paragraph in the ENVIRONMENT DIVISION to define the files in a COBOL program as line-sequential files, and to associate the files with the corresponding external file-names (ddnames or environment variable names).

An external file-name is the name by which a file is known to the operating system. In the following example, COMMUTER-FILE is the name that your program uses for the file; COMMUTR is the external name:

```
FILE-CONTROL.  
  SELECT COMMUTER-FILE  
  ASSIGN TO COMMUTR  
  ORGANIZATION IS LINE SEQUENTIAL  
  ACCESS MODE IS SEQUENTIAL  
  FILE STATUS IS ECODE.
```

The ASSIGN *assignment-name* clause must not include an organization field (S- or AS-) before the external name. The ACCESS phrase and the FILE STATUS clause are optional.

RELATED TASKS

“Describing the structure of a line-sequential file” on page 214

“Allocating line-sequential files” on page 214

“Coding input-output statements for line-sequential files” on page 215

RELATED REFERENCES

“Control characters in line-sequential files”

Describing the structure of a line-sequential file

In the FILE SECTION, code a file description (FD) entry for the file. In the associated record description entry or entries, define the *record-name* and record length.

Code the logical size in bytes of the records by using the RECORD clause. Line-sequential files are stream files. Because of their character-oriented nature, the physical records are of variable length.

The following examples show how the FD entry might look for a line-sequential file:

With fixed-length records:

```
FILE SECTION.  
FD  COMMUTER-FILE  
   RECORD CONTAINS 80 CHARACTERS.  
01  COMMUTER-RECORD.  
   05  COMMUTER-NUMBER          PIC  X(16).  
   05  COMMUTER-DESCRIPTION     PIC  X(64).
```

With variable-length records:

```
FILE SECTION.  
FD  COMMUTER-FILE  
   RECORD VARYING FROM 16 TO 80 CHARACTERS.  
01  COMMUTER-RECORD.  
   05  COMMUTER-NUMBER          PIC  X(16).  
   05  COMMUTER-DESCRIPTION     PIC  X(64).
```

If you code the same fixed size and no OCCURS DEPENDING ON clause for any level-01 record description entries associated with the file, that fixed size is the logical record length. However, because blanks at the end of a record are not written to the file, the physical records might be of varying lengths.

RELATED TASKS

“Allocating line-sequential files”

“Coding input-output statements for line-sequential files” on page 215

RELATED REFERENCES

Data division--file description entries (*Enterprise COBOL Language Reference*)

Control characters in line-sequential files

A line-sequential file can contain control characters. Be aware though that if a line-sequential file contains a newline character (X'15'), the newline character will function as a record delimiter.

Control characters other than newline are treated as data and are part of the record.

Allocating line-sequential files

You can allocate a line-sequential file in the z/OS UNIX file system by using either a DD statement or an environment variable. Allocation of line-sequential files follows the general rules for allocating COBOL files.

To allocate a line-sequential file, code a DD allocation or an environment variable that has a name that matches the external name in the ASSIGN clause:

- A DD allocation:
 - A DD statement that specifies `PATH='absolute-path-name'`
 - A TSO allocation that specifies `PATH('absolute-path-name')`
- An environment variable that has a value of `PATH(absolute-path-name)`. No other values can be specified.

You can optionally also specify these options:

- `PATHOPTS`
- `PATHMODE`
- `PATHDISP`

For example, to have your program use z/OS UNIX file `/u/myfiles/commuterfile` for a COBOL file that has an *assignment-name* of `COMMUTR`, you can use the following command:

```
export COMMUTR="PATH(/u/myfiles/commuterfile)"
```

RELATED TASKS

“Allocating files” on page 157

“Defining line-sequential files and records in COBOL” on page 213

RELATED REFERENCES

MVS Program Management: User's Guide and Reference

Coding input-output statements for line-sequential files

Code the input and output statements shown below to process a line-sequential file.

OPEN To initiate the processing of a file.

You can open a line-sequential file as `INPUT`, `OUTPUT`, or `EXTEND`. You cannot open a line-sequential file as `I-0`.

READ To read a record from a file.

With sequential processing, a program reads one record after another in the same order in which the records were entered when the file was created.

WRITE To create a record in a file.

A program writes new records to the end of the file.

CLOSE To release the connection between a file and the program.

RELATED TASKS

“Defining line-sequential files and records in COBOL” on page 213

“Describing the structure of a line-sequential file” on page 214

“Opening line-sequential files” on page 216

“Reading records from line-sequential files” on page 216

“Adding records to line-sequential files” on page 217

“Closing line-sequential files” on page 217

“Handling errors in line-sequential files” on page 218

RELATED REFERENCES

`OPEN` statement (*Enterprise COBOL Language Reference*)

`READ` statement (*Enterprise COBOL Language Reference*)

WRITE statement (*Enterprise COBOL Language Reference*)

CLOSE statement (*Enterprise COBOL Language Reference*)

Opening line-sequential files

Before your program can use any READ or WRITE statements to process records in a file, it must first open the file with an OPEN statement. An OPEN statement works if the file is available or has been dynamically allocated.

Code CLOSE WITH LOCK so that the file cannot be opened again while the program is running.

RELATED TASKS

“Reading records from line-sequential files”

“Adding records to line-sequential files” on page 217

“Closing line-sequential files” on page 217

“Allocating line-sequential files” on page 214

RELATED REFERENCES

OPEN statement (*Enterprise COBOL Language Reference*)

CLOSE statement (*Enterprise COBOL Language Reference*)

Reading records from line-sequential files

To read from a line-sequential file, open the file and use the READ statement. Your program reads one record after another in the same order in which the records were entered when the file was created.

Characters in the file record are read one at a time into the record area until one of the following conditions occurs:

- The record delimiter (the EBCDIC newline character) is encountered.
The delimiter is discarded and the remainder of the record area is filled with spaces. (Record area is longer than the file record.)
- The entire record area is filled with characters.
If the next unread character is the record delimiter, it is discarded. The next READ reads from the first character of the next record. (Record area is the same length as the file record.)
Otherwise the next unread character is the first character to be read by the next READ. (Record area is shorter than the file record.)
- End-of-file is encountered.
The remainder of the record area is filled with spaces. (Record area is longer than the file record.)

RELATED TASKS

“Opening line-sequential files”

“Adding records to line-sequential files” on page 217

“Closing line-sequential files” on page 217

“Allocating line-sequential files” on page 214

RELATED REFERENCES

OPEN statement (*Enterprise COBOL Language Reference*)

WRITE statement (*Enterprise COBOL Language Reference*)

Adding records to line-sequential files

To add to a line-sequential file, open the file as EXTEND and use the WRITE statement to add records immediately after the last record in the file.

Blanks at the end of the record area are removed, and the record delimiter is added. The characters in the record area from the first character up to and including the added record delimiter are written to the file as one record.

Records written to line-sequential files must contain only USAGE DISPLAY and DISPLAY-1 items. Zoned decimal data items must be unsigned or declared with the SEPARATE phrase of the SIGN clause if signed.

RELATED TASKS

“Opening line-sequential files” on page 216

“Reading records from line-sequential files” on page 216

“Closing line-sequential files”

“Allocating line-sequential files” on page 214

RELATED REFERENCES

OPEN statement (*Enterprise COBOL Language Reference*)

WRITE statement (*Enterprise COBOL Language Reference*)

Closing line-sequential files

Use the CLOSE statement to disconnect your program from a line-sequential file. If you try to close a file that is already closed, you will get a logic error.

If you do not close a line-sequential file, the file is automatically closed for you under the following conditions:

- When the run unit ends normally.
- When the run unit ends abnormally, if the TRAP(ON) runtime option is set.
- When Language Environment condition handling is completed and the application resumes in a routine other than where the condition occurred, open files defined in any COBOL programs in the run unit that might be called again and reentered are closed.

You can change the location where the program resumes (after a condition is handled) by moving the resume cursor with the Language Environment CEEMRCR callable service or using HLL language constructs such as a C longjmp call.

File status codes are set when these implicit CLOSE operations are performed, but EXCEPTION/ERROR declaratives are not invoked.

RELATED TASKS

“Opening line-sequential files” on page 216

“Reading records from line-sequential files” on page 216

“Adding records to line-sequential files”

“Allocating line-sequential files” on page 214

RELATED REFERENCES

CLOSE statement (*Enterprise COBOL Language Reference*)

Handling errors in line-sequential files

When an input or output statement fails, COBOL does not take corrective action for you. You choose whether your program should continue running after an input or output statement fails.

COBOL provides these language elements for intercepting and handling certain line-sequential input and output errors:

- End-of-file phrase (AT END)
- EXCEPTION/ERROR declarative
- FILE STATUS clause

If you do not use one of these techniques, an error in processing input or output raises a Language Environment condition.

If you use the FILE STATUS clause, be sure to check the key and take appropriate action based on its value. If you do not check the key, your program might continue, but the results will probably not be what you expected.

RELATED TASKS

“Coding input-output statements for line-sequential files” on page 215

“Handling errors in input and output operations” on page 241

Chapter 12. Sorting and merging files

You can arrange records in a particular sequence by using a SORT or MERGE statement. You can mix SORT and MERGE statements in the same COBOL program.

Note: The SORT statement, sort processes, and sort restrictions that are described in this topic relate to the format 1 SORT statement only. For more information about sorting a table by using the format 2 SORT statement, see “Sorting a table” on page 88.

SORT statement

Accepts input (from a file or an internal procedure) that is not in sequence, and produces output (to a file or an internal procedure) in a requested sequence. You can add, delete, or change records before or after they are sorted.

MERGE statement

Compares records from two or more sequenced files and combines them in order. You can add, delete, or change records after they are merged.

A program can contain any number of sort and merge operations. They can be the same operation performed many times or different operations. However, one operation must finish before another begins.

With Enterprise COBOL, your IBM licensed program for sorting and merging must be DFSORT or an equivalent. Where DFSORT is mentioned, you can use any equivalent sort or merge product.

COBOL programs that contain SORT or MERGE statements can reside above or below the 16 MB line.

The steps you take to sort or merge are generally as follows:

1. Describe the sort or merge file to be used for sorting or merging.
2. Describe the input to be sorted or merged. If you want to process the records before you sort them, code an input procedure.
3. Describe the output from sorting or merging. If you want to process the records after you sort or merge them, code an output procedure.
4. Request the sort or merge.
5. Determine whether the sort or merge operation was successful.

Restrictions:

- You cannot run a COBOL program that contains SORT or MERGE statements under z/OS UNIX. This restriction includes BPXBATCH.
- You cannot use SORT or MERGE statements in programs compiled with the THREAD option. This includes programs that use object-oriented syntax and multithreaded applications, both of which require the THREAD option.

RELATED CONCEPTS

“Sort and merge process” on page 220

RELATED TASKS

“Sorting a table” on page 88

“Describing the sort or merge file”
“Describing the input to sorting or merging” on page 221
“Describing the output from sorting or merging” on page 223
“Requesting the sort or merge” on page 226
“Determining whether the sort or merge was successful” on page 230
“Stopping a sort or merge operation prematurely” on page 231
“Improving sort performance with FASTSORT” on page 231
“Controlling sort behavior” on page 234
DFSORT Application Programming Guide

RELATED REFERENCES

“CICS SORT application restrictions” on page 237
SORT statement (*Enterprise COBOL Language Reference*)
MERGE statement (*Enterprise COBOL Language Reference*)

Sort and merge process

During the sorting of a file, all of the records in the file are ordered according to the contents of one or more fields (*keys*) in each record. You can sort the records in either ascending or descending order of each key.

If there are multiple keys, the records are first sorted according to the content of the first (or primary) key, then according to the content of the second key, and so on.

To sort a file, use the format 1 SORT statement.

During the merging of two or more files (which must already be sorted), the records are combined and ordered according to the contents of one or more keys in each record. You can order the records in either ascending or descending order of each key. As with sorting, the records are first ordered according to the content of the primary key, then according to the content of the second key, and so on.

Use MERGE . . . USING to name the files that you want to combine into one sequenced file. The merge operation compares keys in the records of the input files, and passes the sequenced records one by one to the RETURN statement of an output procedure or to the file that you name in the GIVING phrase.

RELATED TASKS

“Setting sort or merge criteria” on page 227

RELATED REFERENCES

SORT statement (*Enterprise COBOL Language Reference*)
MERGE statement (*Enterprise COBOL Language Reference*)

Describing the sort or merge file

Describe the sort file to be used for sorting or merging. You need SELECT clauses and SD entries even if you are sorting or merging data items only from WORKING-STORAGE or LOCAL-STORAGE.

Code as follows:

1. Write one or more SELECT clauses in the FILE-CONTROL paragraph of the ENVIRONMENT DIVISION to name a sort file. For example:

```

ENVIRONMENT DIVISION.
INPUT-OUTPUT SECTION.
FILE-CONTROL.
    SELECT Sort-Work-1 ASSIGN TO SortFile.

```

Sort-Work-1 is the name of the file in your program. Use this name to refer to the file.

2. Describe the sort file in an SD entry in the FILE SECTION of the DATA DIVISION. Every SD entry must contain a record description. For example:

```

DATA DIVISION.
FILE SECTION.
SD Sort-Work-1
    RECORD CONTAINS 100 CHARACTERS.
01 SORT-WORK-1-AREA.
    05 SORT-KEY-1    PIC X(10).
    05 SORT-KEY-2    PIC X(10).
    05 FILLER        PIC X(80).

```

The file described in an SD entry is the working file used for a sort or merge operation. You cannot perform any input or output operations on this file and you do not need to provide a ddname definition for it.

RELATED REFERENCES

“FILE SECTION entries” on page 12

Describing the input to sorting or merging

Describe the input file or files for sorting or merging by following the procedure below.

1. Write one or more SELECT clauses in the FILE-CONTROL paragraph of the ENVIRONMENT DIVISION to name the input files. For example:

```

ENVIRONMENT DIVISION.
INPUT-OUTPUT SECTION.
FILE-CONTROL.
    SELECT Input-File ASSIGN TO InFile.

```

Input-File is the name of the file in your program. Use this name to refer to the file.

2. Describe the input file (or files when merging) in an FD entry in the FILE SECTION of the DATA DIVISION. For example:

```

DATA DIVISION.
FILE SECTION.
FD Input-File
    LABEL RECORDS ARE STANDARD
    BLOCK CONTAINS 0 CHARACTERS
    RECORDING MODE IS F
    RECORD CONTAINS 100 CHARACTERS.
01 Input-Record    PIC X(100).

```

RELATED TASKS

“Coding the input procedure” on page 222

“Requesting the sort or merge” on page 226

RELATED REFERENCES

“FILE SECTION entries” on page 12

Example: describing sort and input files for SORT

The following example shows the ENVIRONMENT DIVISION and DATA DIVISION entries needed to describe sort work files and an input file.

```

ID Division.
Program-ID. Smp1Sort.
Environment Division.
Input-Output Section.
File-Control.
*
* Assign name for a working file is treated as documentation.
*
    Select Sort-Work-1 Assign To SortFile.
    Select Sort-Work-2 Assign To SortFile.
    Select Input-File Assign To InFile.
. . .
Data Division.
File Section.
SD Sort-Work-1
    Record Contains 100 Characters.
01 Sort-Work-1-Area.
    05 Sort-Key-1 Pic X(10).
    05 Sort-Key-2 Pic X(10).
    05 Filler Pic X(80).
SD Sort-Work-2
    Record Contains 30 Characters.
01 Sort-Work-2-Area.
    05 Sort-Key Pic X(5).
    05 Filler Pic X(25).
FD Input-File
    Label Records Are Standard
    Block Contains 0 Characters
    Recording Mode is F
    Record Contains 100 Characters.
01 Input-Record Pic X(100).
. . .
Working-Storage Section.
01 EOS-Sw Pic X.
01 Filler.
    05 Table-Entry Occurs 100 Times
        Indexed By X1 Pic X(30).
. . .

```

RELATED TASKS

“Requesting the sort or merge” on page 226

Coding the input procedure

To process the records in an input file before they are released to the sort program, use the INPUT PROCEDURE phrase of the format 1 SORT statement.

You can use an input procedure to:

- Release data items to the sort file from WORKING-STORAGE or LOCAL-STORAGE.
- Release records that have already been read elsewhere in the program.
- Read records from an input file, select or process them, and release them to the sort file.

Each input procedure must be contained in either paragraphs or sections. For example, to release records from a table in WORKING-STORAGE or LOCAL-STORAGE to the sort file SORT-WORK-2, you could code as follows:

```

SORT SORT-WORK-2
    ON ASCENDING KEY SORT-KEY
    INPUT PROCEDURE 600-SORT3-INPUT-PROC
. . .
600-SORT3-INPUT-PROC SECTION.

```

```

PERFORM WITH TEST AFTER
  VARYING X1 FROM 1 BY 1 UNTIL X1 = 100
  RELEASE SORT-WORK-2-AREA FROM TABLE-ENTRY (X1)
END-PERFORM.

```

To transfer records to the sort program, all input procedures must contain at least one RELEASE or RELEASE FROM statement. To release A from X, for example, you can code:

```

MOVE X TO A.
RELEASE A.

```

Alternatively, you can code:

```

RELEASE A FROM X.

```

The following table compares the RELEASE and RELEASE FROM statements.

RELEASE	RELEASE FROM
<pre> MOVE EXT-RECORD TO SORT-EXT-RECORD PERFORM RELEASE-SORT-RECORD . . . RELEASE-SORT-RECORD. RELEASE SORT-RECORD </pre>	<pre> PERFORM RELEASE-SORT-RECORD . . . RELEASE-SORT-RECORD. RELEASE SORT-RECORD FROM SORT-EXT-RECORD </pre>

RELATED REFERENCES

“Restrictions on input and output procedures” on page 225
 RELEASE statement (*Enterprise COBOL Language Reference*)

Describing the output from sorting or merging

If the output from sorting or merging is a file, describe the file by following the procedure below.

1. Write a SELECT clause in the FILE-CONTROL paragraph of the ENVIRONMENT DIVISION to name the output file. For example:

```

ENVIRONMENT DIVISION.
INPUT-OUTPUT SECTION.
FILE-CONTROL.
  SELECT Output-File ASSIGN TO OutFile.

```

Output-File is the name of the file in your program. Use this name to refer to the file.

2. Describe the output file (or files when merging) in an FD entry in the FILE SECTION of the DATA DIVISION. For example:

```

DATA DIVISION.
FILE SECTION.
FD Output-File
  LABEL RECORDS ARE STANDARD
  BLOCK CONTAINS 0 CHARACTERS
  RECORDING MODE IS F
  RECORD CONTAINS 100 CHARACTERS.
01 Output-Record PIC X(100).

```

RELATED TASKS

“Coding the output procedure” on page 224
 “Requesting the sort or merge” on page 226

Coding the output procedure

To select, edit, or otherwise change sorted records before writing them from the sort work file into another file, use the OUTPUT PROCEDURE phrase of the format 1 SORT statement.

Each output procedure must be contained in either a section or a paragraph. An output procedure must include both of the following elements:

- At least one RETURN statement or one RETURN statement with the INTO phrase
- Any statements necessary to process the records that are made available, one at a time, by the RETURN statement

The RETURN statement makes each sorted record available to the output procedure. (The RETURN statement for a sort file is similar to a READ statement for an input file.)

You can use the AT END and END-RETURN phrases with the RETURN statement. The imperative statements in the AT END phrase are performed after all the records have been returned from the sort file. The END-RETURN explicit scope terminator delimits the scope of the RETURN statement.

If you use RETURN INTO instead of RETURN, the records will be returned to WORKING-STORAGE, LOCAL-STORAGE, or to an output area.

DFSORT coding: If you use DFSORT and a RETURN statement does not encounter an AT END condition before a COBOL program finishes running, the format 1 SORT statement could end abnormally with DFSORT message IEC025A. To avoid this situation, be sure to code the RETURN statement with the AT END phrase. In addition, ensure that the RETURN statement is executed until the AT END condition is encountered. The AT END condition occurs after the last record is returned to the program from the sort work file and a subsequent RETURN statement is executed.

"Example: coding the output procedure when using DFSORT"

RELATED REFERENCES
"Restrictions on input and output procedures" on page 225
RETURN statement (*Enterprise COBOL Language Reference*)

Example: coding the output procedure when using DFSORT

The following example shows a coding technique that ensures that the RETURN statement encounters the AT END condition before the program finishes running. The RETURN statement, coded with the AT END phrase, is executed until the AT END condition occurs.

```
IDENTIFICATION DIVISION.  
DATA DIVISION.  
FILE SECTION.  
SD OUR-FILE.  
01 OUR-SORT-REC.  
    03 SORT-KEY          PIC X(10).  
    03 FILLER            PIC X(70).  
    . . .  
WORKING-STORAGE SECTION.  
01 WS-SORT-REC          PIC X(80).  
01 END-OF-SORT-FILE-INDICATOR PIC X VALUE 'N'.  
    88 NO-MORE-SORT-RECORDS      VALUE 'Y'.
```



```

. . .
PROCEDURE DIVISION.
A-CONTROL SECTION.
  SORT OUR-FILE ON ASCENDING KEY SORT-KEY
  INPUT PROCEDURE IS B-INPUT
  OUTPUT PROCEDURE IS C-OUTPUT.

. . .
B-INPUT SECTION.
  MOVE . . . . . TO WS-SORT-REC.
  RELEASE OUR-SORT-REC FROM WS-SORT-REC.

. . .
C-OUTPUT SECTION.
  DISPLAY 'STARTING READS OF SORTED RECORDS: '.
  RETURN OUR-FILE
  AT END
    SET NO-MORE-SORT-RECORDS TO TRUE.
  PERFORM WITH TEST BEFORE UNTIL NO-MORE-SORT-RECORDS
  IF SORT-RETURN = 0 THEN
    DISPLAY 'OUR-SORT-REC = ' OUR-SORT-REC
    RETURN OUR-FILE
  AT END
    SET NO-MORE-SORT-RECORDS TO TRUE
  END-IF
END-PERFORM.

```

Restrictions on input and output procedures

Several restrictions apply to each input or output procedure called by SORT and to each output procedure called by MERGE.

Observe these restrictions:

- The procedure must not contain any SORT or MERGE statements.
- You can use ALTER, GO TO, and PERFORM statements in the procedure to refer to procedure-names outside the input or output procedure. However, control must return to the input or output procedure after a GO TO or PERFORM statement.
- The remainder of the PROCEDURE DIVISION must not contain any transfers of control to points inside the input or output procedure (with the exception of the return of control from a declarative section).
- In an input or output procedure, you can call a program that follows standard linkage conventions. However, the called program cannot issue a SORT or MERGE statement.
- During a SORT or MERGE operation, the SD data item is used. You must not use it in the output procedure before the first RETURN executes. If you move data into this record area before the first RETURN statement, the first record to be returned will be overwritten.
- Language Environment condition handling does not let user-written condition handlers be established in an input or output procedure.

RELATED TASKS

“Coding the input procedure” on page 222

“Coding the output procedure” on page 224

Language Environment Programming Guide (Preparing to link-edit and run)

Defining sort and merge data sets

To use DFSORT under z/OS, code DD statements in the runtime JCL to describe the necessary data sets that are listed below.

Sort or merge work

Define a minimum of three data sets: SORTWK01, SORTWK02, SORTWK03, . . . , SORTWK nm (where nm is 99 or less). These data sets cannot be in the z/OS UNIX file system.

SYSOUT Define for sort diagnostic messages, unless you change the data-set name. (Change the name using either the MSGDDN keyword of the OPTION control statement in the SORT-CONTROL data set, or using the SORT-MESSAGE special register.)

SORTCKPT

Define if the sort or merge is to take checkpoints.

Input and output

Define input and output data sets, if any.

SORTLIB (DFSORT library)

Define the library that contains the sort modules, for example, SYS1.SORTLIB.

RELATED TASKS

“Controlling sort behavior” on page 234

“Using checkpoint/restart with DFSORT” on page 236

Sorting variable-length records

Your sort work file will be variable length only if you define it to be variable length, even if the input file to the sort contains variable-length records.

The compiler determines that the sort work file is variable length if you code one of the following elements in the SD entry:

- A RECORD IS VARYING clause
- Two or more record descriptions that define records that have different sizes, or records that contain an OCCURS DEPENDING ON clause

You cannot use RECORDING MODE V for the sort work file because the SD entry does not allow the RECORDING MODE clause.

Performance consideration: To improve sort performance of variable-length files, specify the most frequently occurring record length of the input file (the modal length) on the SMS= control card or in the SORT-MODE-SIZE special register.

RELATED TASKS

“Changing DFSORT defaults with control statements” on page 235

“Controlling sort behavior” on page 234

Requesting the sort or merge

To read records from an input file (files for MERGE) without preliminary processing, use SORT . . . USING or MERGE . . . USING and the name of the input file (files) that you declared in a SELECT clause.

To transfer sorted or merged records from the sort or merge program to another file without any further processing, use SORT . . . GIVING or MERGE . . . GIVING and the name of the output file that you declared in a SELECT clause. For example:

```

SORT Sort-Work-1
  ON ASCENDING KEY Sort-Key-1
  USING Input-File
  GIVING Output-File.

```

For SORT . . . USING or MERGE . . . USING, the compiler generates an input procedure to open the file (files), read the records, release the records to the sort or merge program, and close the file (files). The file (files) must not be open when the SORT or MERGE statement begins execution. For SORT . . . GIVING or MERGE . . . GIVING, the compiler generates an output procedure to open the file, return the records, write the records, and close the file. The file must not be open when the SORT or MERGE statement begins execution.

The USING or GIVING files in a SORT or MERGE statement can be sequential files residing in the z/OS UNIX file system.

“Example: describing sort and input files for SORT” on page 221

If you want an input procedure to be performed on the sort records before they are sorted, use SORT . . . INPUT PROCEDURE. If you want an output procedure to be performed on the sorted records, use SORT . . . OUTPUT PROCEDURE. For example:

```

SORT Sort-Work-1
  ON ASCENDING KEY Sort-Key-1
  INPUT PROCEDURE EditInputRecords
  OUTPUT PROCEDURE FormatData.

```

“Example: sorting with input and output procedures” on page 228

Restriction: You cannot use an input procedure with the MERGE statement. The source of input to the merge operation must be a collection of already sorted files. However, if you want an output procedure to be performed on the merged records, use MERGE . . . OUTPUT PROCEDURE. For example:

```

MERGE Merge-Work
  ON ASCENDING KEY Merge-Key
  USING Input-File-1 Input-File-2 Input-File-3
  OUTPUT PROCEDURE ProcessOutput.

```

In the FILE SECTION, you must define *Merge-Work* in an SD entry, and the input files in FD entries.

RELATED TASKS

“Defining sort and merge data sets” on page 225

RELATED REFERENCES

SORT statement (*Enterprise COBOL Language Reference*)

MERGE statement (*Enterprise COBOL Language Reference*)

Setting sort or merge criteria

To set sort or merge criteria, define the keys on which the operation is to be performed.

Note: The process of setting sort criteria that is described in this topic relates to the format 1 SORT statement only. For more information about sorting a table by using the format 2 SORT statement, see “Sorting a table” on page 88.

Do these steps:

1. In the record description of the files to be sorted or merged, define the key or keys.

There is no maximum number of keys, but the keys must be located in the first 4092 bytes of the record description. The total length of the keys cannot exceed 4092 bytes unless the EQUALS keyword is coded in the DFSORT OPTION control statement, in which case the total length of the keys must not exceed 4088 bytes.

Restriction: A key cannot be variably located.

2. In the SORT or MERGE statement, specify the key fields to be used for sequencing by coding the ASCENDING or DESCENDING KEY phrase, or both. When you code more than one key, some can be ascending, and some descending.

Specify the names of the keys in decreasing order of significance. The leftmost key is the primary key. The next key is the secondary key, and so on.

SORT and MERGE keys can be of class alphabetic, alphanumeric, national, or numeric (but not numeric of USAGE NATIONAL). If it has USAGE NATIONAL, a key can be of category national or can be a national-edited or numeric-edited data item. A key cannot be a national decimal data item or a national floating-point data item.

The collation order for national keys is determined by the binary order of the keys. If you specify a national data item as a key, any COLLATING SEQUENCE phrase in the SORT or MERGE statement does not apply to that key.

You can mix SORT and MERGE statements in the same COBOL program. A program can perform any number of sort or merge operations. However, one operation must end before another can begin.

RELATED TASKS

"Sorting a table" on page 88

RELATED REFERENCES

DFSORT Application Programming Guide (SORT control statement)

SORT statement (*Enterprise COBOL Language Reference*)

MERGE statement (*Enterprise COBOL Language Reference*)

Example: sorting with input and output procedures

The following example shows the use of an input and an output procedure in a format 1 SORT statement. The example also shows how you can define a primary key (SORT-GRID-LOCATION) and a secondary key (SORT-SHIFT) before using them in the format 1 SORT statement.

```
DATA DIVISION.
. . .
SD SORT-FILE
RECORD CONTAINS 115 CHARACTERS
DATA RECORD SORT-RECORD.
01 SORT-RECORD.
05 SORT-KEY.
10 SORT-SHIFT PIC X(1).
10 SORT-GRID-LOCATION PIC X(2).
10 SORT-REPORT PIC X(3).
05 SORT-EXT-RECORD.
10 SORT-EXT-EMPLOYEE-NUM PIC X(6).
10 SORT-EXT-NAME PIC X(30).
10 FILLER PIC X(73).
. . .
WORKING-STORAGE SECTION.
01 TAB1.
```

```

05 TAB-ENTRY OCCURS 10 TIMES
   INDEXED BY TAB-INDX.
   10 WS-SHIFT                PIC X(1).
   10 WS-GRID-LOCATION         PIC X(2).
   10 WS-REPORT               PIC X(3).
   10 WS-EXT-EMPLOYEE-NUM    PIC X(6).
   10 WS-EXT-NAME             PIC X(30).
   10 FILLER                  PIC X(73).

. . .
PROCEDURE DIVISION.

. . .
SORT SORT-FILE
  ON ASCENDING KEY SORT-GRID-LOCATION SORT-SHIFT
  INPUT PROCEDURE 600-SORT3-INPUT
  OUTPUT PROCEDURE 700-SORT3-OUTPUT.

. . .
600-SORT3-INPUT.
  PERFORM VARYING TAB-INDX FROM 1 BY 1 UNTIL TAB-INDX > 10
  RELEASE SORT-RECORD FROM TAB-ENTRY(TAB-INDX)
  END-PERFORM.

. . .
700-SORT3-OUTPUT.
  PERFORM VARYING TAB-INDX FROM 1 BY 1 UNTIL TAB-INDX > 10
  RETURN SORT-FILE INTO TAB-ENTRY(TAB-INDX)
  AT END DISPLAY 'Out Of Records In SORT File'
  END-RETURN
  END-PERFORM.

```

RELATED TASKS

“Requesting the sort or merge” on page 226

Choosing alternate collating sequences

You can sort or merge records on the EBCDIC or ASCII collating sequence, or on another collating sequence. The default collating sequence is EBCDIC unless you code the PROGRAM COLLATING SEQUENCE clause in the OBJECT-COMPUTER paragraph.

To override the default sequence, use the COLLATING SEQUENCE phrase of the SORT or MERGE statement. You can use different collating sequences for each SORT or MERGE statement in your program.

The PROGRAM COLLATING SEQUENCE clause and the COLLATING SEQUENCE phrase apply only to keys of class alphabetic or alphanumeric.

When you sort or merge an ASCII file, you have to request the ASCII collating sequence. To do so, code the COLLATING SEQUENCE phrase of the SORT or MERGE statement, and define the *alphabet-name* as STANDARD-1 in the SPECIAL-NAMES paragraph.

RELATED TASKS

“Specifying the collating sequence” on page 6

“Setting sort or merge criteria” on page 227

RELATED REFERENCES

OBJECT-COMPUTER paragraph (*Enterprise COBOL Language Reference*)

SORT statement (*Enterprise COBOL Language Reference*)

Classes and categories of data (*Enterprise COBOL Language Reference*)

Preserving the original sequence of records with equal keys

You can preserve the order of identical collating records from input to output.

Use one of these techniques:

- Install DFSORT with the EQUALS option as the default.
- Provide, at run time, an OPTION card that has the EQUALS keyword in the IGZSRTCD data set.
- Use the WITH DUPLICATES IN ORDER phrase in the SORT statement. Doing so adds the EQUALS keyword to the OPTION card in the IGZSRTCD data set.

Do not use both the NOEQUALS keyword on the OPTION card *and* the DUPLICATES phrase, or the run unit will end.

RELATED REFERENCES

DFSORT Application Programming Guide (OPTION control statement)

Determining whether the sort or merge was successful

The DFSORT program returns a completion code of either 0 (successful completion) or 16 (unsuccessful completion) after each sort or merge has finished. The completion code is stored in the SORT-RETURN special register.

You should test for successful completion after each SORT or MERGE statement. For example:

```
SORT SORT-WORK-2
  ON ASCENDING KEY SORT-KEY
  INPUT PROCEDURE IS 600-SORT3-INPUT-PROC
  OUTPUT PROCEDURE IS 700-SORT3-OUTPUT-PROC.
IF SORT-RETURN NOT=0
  DISPLAY "SORT ENDED ABNORMALLY. SORT-RETURN = " SORT-RETURN.
. . .
600-SORT3-INPUT-PROC SECTION.
. . .
700-SORT3-OUTPUT-PROC SECTION.
. . .
```

If you do not reference SORT-RETURN anywhere in your program, the COBOL run time tests the completion code. If it is 16, COBOL issues a runtime diagnostic message.

By default, DFSORT diagnostic messages are sent to the SYSOUT data set. If you want to change this default, use the MSGDDN parameter of the DFSORT OPTION control card or use the SORT-MESSAGE special register.

If you test SORT-RETURN for one or more (but not necessarily all) SORT or MERGE statements, the COBOL run time does not check the completion code.

RELATED TASKS

“Checking for sort errors with NOFASTSRT” on page 233

“Controlling sort behavior” on page 234

RELATED REFERENCES

DFSORT Application Programming Guide (DFSORT messages and return codes)

Stopping a sort or merge operation prematurely

To stop a sort or merge operation, move the integer 16 into the SORT-RETURN special register.

Move 16 into the register in either of the following ways:

- Use MOVE in an input or output procedure.
Sort or merge processing will be stopped immediately after the next RELEASE or RETURN statement is performed.
- Reset the register in a declarative section entered during processing of a USING or GIVING file.
Sort or merge processing will be stopped immediately after the next implicit RELEASE or RETURN is performed, which will occur after a record has been read from or written to the USING or GIVING file.

Control then returns to the statement following the SORT or MERGE statement.

Improving sort performance with FASTSRT

Using the FASTSRT compiler option improves the performance of most sort operations. With FASTSRT, the DFSORT product (instead of Enterprise COBOL) performs the I/O on the input and output files you name in the SORT . . . USING and SORT . . . GIVING statements.

The compiler issues informational messages to point out statements in which FASTSRT can improve performance.

Usage notes

- You cannot use the DFSORT options SORTIN or SORTOUT if you use FASTSRT. The FASTSRT compiler option does not apply to line-sequential files you use as USING or GIVING files.
- If you specify file status and use FASTSRT, file status is ignored during the sort.

RELATED REFERENCES

“FASTSRT” on page 327

“FASTSRT requirements for JCL”

“FASTSRT requirements for sort input and output files”

FASTSRT requirements for JCL

In the runtime JCL, you must assign the sort work files (SORTWKnn) to a direct-access device, not to tape data sets.

For the input and output files, the DCB parameter of the DD statement must match the FD description.

FASTSRT requirements for sort input and output files

If you specify FASTSRT but your code does not meet FASTSRT requirements, the compiler issues a message and the COBOL run time performs the I/O instead. Your program will not experience the performance improvements that are otherwise possible.

Note: The “sort input and output files” that is described in this topic relates to the format 1 SORT statement only.

To use FASTSORT, you must describe and process the input files to the sort and the output files from the sort in these ways:

- You can name only one input file in the USING phrase. You can name only one output file in the GIVING phrase.
- You cannot use an input procedure on an input file nor an output procedure on an output file.

Instead of using input or output procedures, you might be able to use these DFSORT control statements:

- INREC
- OUTFILE
- OUTREC
- INCLUDE
- OMIT
- STOPAFT
- SKIPREC
- SUM

Many DFSORT functions perform the same operations that are common in input or output procedures. Code the appropriate DFSORT control statements instead, and place them either in the IGZSRTCD or SORTCNTL data set.

- Do not code the LINAGE clause for the output FD entry.
- Do not code any INPUT declarative (for input files), OUTPUT declarative (for output files), or file-specific declaratives (for either input or output files) to apply to any FDs used in the sort.
- Do not use a variable relative file as the input or output file.
- Do not use a line-sequential file as the input or output file.
- For either an input or an output file, the record descriptions of the SD and FD entry must define the same format (fixed or variable), and the largest records of the SD and FD entry must define the same record length.

If you code a RELATIVE KEY clause for an output file, it will not be set by the sort.

Performance tip: If you block your input and output records, the sort performance could be significantly improved.

QSAM requirements

- QSAM files must have a record format of fixed, variable, or spanned.
- A QSAM input file can be empty.
- To use the same QSAM file for both input and output, you must describe the file using two different DD statements. For example, in the FILE-CONTROL SECTION you might code this:

```
SELECT FILE-IN ASSIGN INPUTF.  
SELECT FILE-OUT ASSIGN OUTPUTF.
```

In the DATA DIVISION, you would have an FD entry for both FILE-IN and FILE-OUT, where FILE-IN and FILE-OUT are identical except for their names.

In the PROCEDURE DIVISION, your SORT statement could look like this:

```
SORT file-name  
  ASCENDING KEY data-name-1  
  USING FILE-IN GIVING FILE-OUT
```

Then in your JCL, assuming that data set INOUT has been cataloged, you would code:

```
//INPUTF DD DSN=INOUT,DISP=SHR
//OUTPUTF DD DSN=INOUT,DISP=SHR
```

On the other hand, if you code the same file-name in the USING and GIVING phrases, or assign the input and output files the same ddname, then the file can be accepted for FASTSORT either for input or output, but not both. If no other conditions disqualify the file from being eligible for FASTSORT on input, then the file will be accepted for FASTSORT on input, but not on output. If the file was found to be ineligible for FASTSORT on input, it might be eligible for FASTSORT on output.

A QSAM file that qualifies for FASTSORT can be accessed by the COBOL program while the format 1 SORT statement is being performed. For example, if the file is used for FASTSORT on input, you can access it in an output procedure; if it is used for FASTSORT on output, you can access it in an input procedure.

VSAM requirements

- A VSAM input file must not be empty.
- VSAM files cannot be password-protected.
- You cannot name the same VSAM file in both the USING and GIVING phrases.
- A VSAM file that qualifies for FASTSORT cannot be accessed by the COBOL program until the format 1 SORT statement processing is completed. For example, if the file qualifies for FASTSORT on input, you cannot access it in an output procedure and vice versa. (If you do so, OPEN fails.)

RELATED TASKS

DFSORT Application Programming Guide

Checking for sort errors with NOFASTSRT

When you compile with the NOFASTSRT option, the sort process does not check for errors in open, close, or input or output operations for files that you reference in the USING or GIVING phrase of the format 1 SORT statement. Therefore, you might need to check whether SORT completed successfully.

Note: This topic relates to the format 1 SORT statement only.

The code required depends on whether you code a FILE STATUS clause or an ERROR declarative for the files referenced in the USING and GIVING phrases, as shown in the table below.

Table 32. Methods for checking for sort errors with NOFASTSRT

FILE STATUS clause?	ERROR declarative?	Then do:
No	No	No special coding. Any failure during the sort process causes the program to end abnormally.
Yes	No	Test the SORT-RETURN special register after the format 1 SORT statement, and test the file status key. (Not recommended if you want complete file-status checking, because the file status code is set but COBOL cannot check it.)
Maybe	Yes	In the ERROR declarative, set the SORT-RETURN special register to 16 to stop the sort process and indicate that it was not successful. Test the SORT-RETURN special register after the format 1 SORT statement.

RELATED TASKS

“Determining whether the sort or merge was successful” on page 230

“Using file status keys” on page 245

“Coding ERROR declaratives” on page 244

“Stopping a sort or merge operation prematurely” on page 231

Controlling sort behavior

You can control several aspects of sort behavior by inserting values in special registers before the sort or by using compiler options. You might also have a choice of control statements and keywords.

You can verify sort behavior by examining the contents of special registers after the sort.

The table below lists those aspects of sort behavior that you can affect by using special registers or compiler options, and the equivalent sort control statement keywords if any are available.

Table 33. Methods for controlling sort behavior

To set or test	Use this special register or compiler option	Or this control statement (and keyword if applicable)
Amount of main storage to be reserved	SORT-CORE-SIZE special register	OPTION (keyword RESINV)
Amount of main storage to be used	SORT-CORE-SIZE special register	OPTION (keywords MAINSIZE or MAINSIZE=MAX)
Modal length of records in a file with variable-length records	SORT-MODE-SIZE special register	SMS=nnnnn
Name of sort control statement data set (default IGZSRTCD)	SORT-CONTROL special register	None
Name of sort message file (default SYSOUT)	SORT-MESSAGE special register	OPTION (keyword MSGDDN)
Number of sort records	SORT-FILE-SIZE special register	OPTION (keyword FILSZ)
Sort completion code	SORT-RETURN special register	None

Sort special registers: SORT-CONTROL is an eight-character COBOL special register that contains the ddname of the sort control statement file. If you do not want to use the default ddname IGZSRTCD, assign to SORT-CONTROL the ddname of the data set that contains your sort control statements.

The SORT-CORE-SIZE, SORT-FILE-SIZE, SORT-MESSAGE, and SORT-MODE-SIZE special registers are used in the SORT interface if you assign them nondefault values. At run time, however, any parameters in control statements in the sort control statement data set override corresponding settings in the special registers, and a message to that effect is issued.

You can use the SORT-RETURN special register to determine whether the sort or merge was successful and to stop a sort or merge operation prematurely.

A compiler warning message (W-level) is issued for each sort special register that you set in a program.

RELATED TASKS

“Determining whether the sort or merge was successful” on page 230
“Stopping a sort or merge operation prematurely” on page 231
“Changing DFSORT defaults with control statements”
“Allocating space for sort files” on page 236
DFSORT Application Programming Guide (Using DFSORT program control statements)

RELATED REFERENCES

“Default characteristics of the IGZSRTCD data set”

Changing DFSORT defaults with control statements

If you want to change DFSORT system defaults to improve sort performance, pass information to DFSORT through control statements in the runtime data set IGZSRTCD.

The control statements that you can include in IGZSRTCD (in the order listed) are:

1. SMS=*nnnnn*, where *nnnnn* is the length in bytes of the most frequently occurring record size. (Use only if the SD file is variable length.)
2. OPTION (except keywords SORTIN or SORTOUT).
3. Other DFSORT control statements (except SORT, MERGE, RECORD, or END).

Code control statements between columns 2 and 71. You can continue a control statement record by ending the line with a comma and starting the next line with a new keyword. You cannot use labels or comments on a record, and a record itself cannot be a DFSORT comment statement.

RELATED TASKS

“Controlling sort behavior” on page 234
DFSORT Application Programming Guide (Using DFSORT program control statements)

RELATED REFERENCES

“Default characteristics of the IGZSRTCD data set”

Default characteristics of the IGZSRTCD data set

The IGZSRTCD data set is optional. Its defaults are LRECL=80, BLKSIZE=400, and ddname IGZSRTCD.

You can use a different ddname by coding it in the SORT-CONTROL special register. If you defined a ddname for the SORT-CONTROL data set and you receive the message IGZ0027W, an OPEN failure occurred that you should investigate.

RELATED TASKS

“Controlling sort behavior” on page 234

Allocating storage for sort or merge operations

Certain parameters set during the installation of DFSORT determine the amount of storage that DFSORT uses. In general, the more storage DFSORT has available, the faster the sort or merge operations in your program will be.

DFSORT installation should not allocate all the free space in the region for its COBOL operation, however. When your program is running, storage must be available for:

- COBOL programs that are dynamically called from an input or output procedure
- Language Environment runtime library modules
- Data management modules that can be loaded into the region for use by an input or output procedure
- Any storage obtained by these modules

For a specific sort or merge operation, you can override the DFSORT storage values set at installation. To do so, code the MAINSIZE and RESINV keywords on the OPTION control statement in the sort control statement data set, or use the SORT-CORE-SIZE special register.

Be careful not to override the storage allocation to the extent that all the free space in the region is used for sort operations for your COBOL program.

RELATED TASKS

“Controlling sort behavior” on page 234
DFSORT Installation and Customization

RELATED REFERENCES

DFSORT Application Programming Guide (OPTION control statement)

Allocating space for sort files

If you use NOFASTSRT or an input procedure, DFSORT does not know the size of the file that you are sorting. This can lead to an out-of-space condition when you sort large files or to overallocation of resources when you sort small files.

If this occurs, you can use the SORT-FILE-SIZE special register to help DFSORT determine the amount of resource (for example, workspace or *hiperspace*) needed for the sort. Set SORT-FILE-SIZE to a reasonable estimate of the number of input records. This value is passed to DFSORT as its FILSZ=*En* value.

RELATED TASKS

“Controlling sort behavior” on page 234
 “Coding the input procedure” on page 222
DFSORT Application Programming Guide

Using checkpoint/restart with DFSORT

You cannot use checkpoints taken while DFSORT is running under z/OS to restart, unless the checkpoints are taken by DFSORT.

Checkpoints taken by a COBOL program while SORT or MERGE statements execute are invalid; such restarts are detected and canceled.

To take a checkpoint during a sort or merge operation, do these steps:

1. Add a DD statement for SORTCKPT in the JCL.
2. Code the RERUN clause in the I-0-CONTROL paragraph:

```
RERUN ON assignment-name
```
3. Code the CKPT (or CHKPT) keyword on an OPTION control statement in the sort control statement data set (default ddname IGZSRTCD).

RELATED CONCEPTS

Chapter 32, “Interrupts and checkpoint/restart,” on page 651

RELATED TASKS

“Changing DFSORT defaults with control statements” on page 235

“Setting checkpoints” on page 651

Sorting under CICS

There is no IBM sort product that is supported under CICS. However, you can use the SORT statement with a sort program you write that runs under CICS to sort small amounts of data.

You must have both an input and an output procedure for the SORT statement. In the input procedure, use the RELEASE statement to transfer records from the COBOL program to the sort program before the sort is performed. In the output procedure, use the RETURN statement to transfer records from the sort program to the COBOL program after the sort is performed.

RELATED TASKS

“Coding the input procedure” on page 222

“Coding the output procedure” on page 224

“Coding COBOL programs to run under CICS” on page 429

RELATED REFERENCES

“CICS SORT application restrictions”

“CICS reserved-word table” on page 437

CICS SORT application restrictions

Several restrictions apply to COBOL applications that run under CICS and use the SORT statement.

The restrictions are:

- SORT statements that include the USING or GIVING phrase are not supported.
- Sort control data sets are not supported. Data in the SORT-CONTROL special register is ignored.
- These CICS commands in the input or output procedures can cause unpredictable results:
 - CICS LINK
 - CICS XCTL
 - CICS RETURN
 - CICS HANDLE
 - CICS IGNORE
 - CICS PUSH
 - CICS POP

You can use CICS commands other than these if you use the NOHANDLE or RESP option. Unpredictable results can occur if you do not use NOHANDLE or RESP.

RELATED REFERENCES

“CICS reserved-word table” on page 437

Chapter 13. Handling errors

Put code in your programs that anticipates possible system or runtime problems. If you do not include such code, output data or files could be corrupted, and the user might not even be aware that there is a problem.

The error-handling code can take actions such as handling the situation, issuing a message, or halting the program. You might for example create error-detection routines for data-entry errors or for errors as your installation defines them. In any event, coding a warning message is a good idea.

Enterprise COBOL contains special elements to help you anticipate and correct error conditions:

- User-requested dumps
- ON OVERFLOW in STRING and UNSTRING operations
- ON SIZE ERROR in arithmetic operations
- Elements for handling input or output errors
- ON EXCEPTION or ON OVERFLOW in CALL statements
- User-written routines for handling errors

RELATED TASKS

“Handling errors in joining and splitting strings” on page 240

“Handling errors in arithmetic operations” on page 240

“Handling errors in input and output operations” on page 241

“Handling errors when calling programs” on page 250

“Writing routines for handling errors” on page 250

Requesting dumps

You can cause a formatted dump of the Language Environment runtime environment and the member language libraries at any prespecified point in your program by coding a call to the Language Environment callable service CEE3DMP.

```
77 Title-1          Pic x(80)  Display.
77 Options          Pic x(255) Display.
01 Feedback-code   Pic x(12)  Display.
. . .
    Call "CEE3DMP" Using Title-1, Options, Feedback-code
```

To have symbolic variables included in the formatted dump, compile with the TEST compiler option and use the VARIABLES subparameter of CEE3DMP. You can also request, through runtime options, that a dump be produced for error conditions of your choosing.

You can cause a system dump at any prespecified point in your program. Request an abend without cleanup by calling the Language Environment service CEE3ABD with a cleanup value of zero. This callable service stops the run unit immediately, and a system dump is requested when the abend is issued.

RELATED REFERENCES

“TEST” on page 364

Handling errors in joining and splitting strings

During the joining or splitting of strings, the pointer used by STRING or UNSTRING might fall outside the range of the receiving field. A potential overflow condition exists, but COBOL does not let the overflow happen.

Instead, the STRING or UNSTRING operation is not completed, the receiving field remains unchanged, and control passes to the next sequential statement. If you do not code the ON OVERFLOW phrase of the STRING or UNSTRING statement, you are not notified of the incomplete operation.

Consider the following statement:

```
String Item-1 space Item-2 delimited by Item-3
      into Item-4
      with pointer String-ptr
      on overflow
      Display "A string overflow occurred"
End-String
```

These are the data values before and after the statement is performed:

Data item	PICTURE	Value before	Value after
Item-1	X(5)	AAAAA	AAAAA
Item-2	X(5)	EEEEA	EEEEA
Item-3	X(2)	EA	EA
Item-4	X(8)	bbbbbbb ¹	bbbbbbb ¹
String-ptr	9(2)	0	0
1. The symbol <i>b</i> represents a blank space.			

Because String-ptr has a value (0) that falls short of the receiving field, an overflow condition occurs and the STRING operation is not completed. (Overflow would also occur if String-ptr were greater than 9.) If ON OVERFLOW had not been specified, you would not be notified that the contents of Item-4 remained unchanged.

Handling errors in arithmetic operations

The results of arithmetic operations might be larger than the fixed-point field that is to hold them, or you might have tried dividing by zero. In either case, the ON SIZE ERROR clause after the ADD, SUBTRACT, MULTIPLY, DIVIDE, or COMPUTE statement can handle the situation.

For ON SIZE ERROR to work correctly for fixed-point overflow and decimal overflow, you must specify the TRAP(ON) runtime option.

The imperative statement of the ON SIZE ERROR clause will be performed and the result field will not change in these cases:

- Fixed-point overflow
- Division by zero
- Zero raised to the zero power

- Zero raised to a negative number
- Negative number raised to a fractional power

Floating-point exponent overflow occurs when the value of a floating-point computation cannot be represented in the System z floating-point operand format. This type of overflow does not cause SIZE ERROR; an abend occurs instead. You could code a user-written condition handler to intercept the abend and provide your own error recovery logic.

Example: checking for division by zero

The following example shows how you can code an ON SIZE ERROR imperative statement so that the program issues an informative message if division by zero occurs.

```

DIVIDE-TOTAL-COST.
  DIVIDE TOTAL-COST BY NUMBER-PURCHASED
  GIVING ANSWER
  ON SIZE ERROR
    DISPLAY "ERROR IN DIVIDE-TOTAL-COST PARAGRAPH"
    DISPLAY "SPENT " TOTAL-COST, " FOR " NUMBER-PURCHASED
  PERFORM FINISH
END-DIVIDE
.
.
.
FINISH.
STOP RUN.

```

If division by zero occurs, the program writes a message and halts program execution.

Handling errors in input and output operations

When an input or output operation fails, COBOL does not automatically take corrective action. You choose whether your program will continue running after a less-than-severe input or output error.

You can use any of the following techniques for intercepting and handling certain input or output conditions or errors:

- End-of-file condition (AT END)
- ERROR declaratives
- FILE STATUS clause and file status key
- File system status code
- Imperative-statement phrases in READ or WRITE statements
 - For VSAM files, if you specify a FILE STATUS clause, you can also test the VSAM status code to direct your program to error-handling logic.
- INVALID KEY phrase

To have your program continue, you must code the appropriate error-recovery procedure. You might code, for example, a procedure to check the value of the file status key. If you do not handle an input or output error in any of these ways, a severity-3 Language Environment condition is signaled, which causes the run unit to end if the condition is not handled.

The following figure shows the flow of logic after a VSAM input or output error:

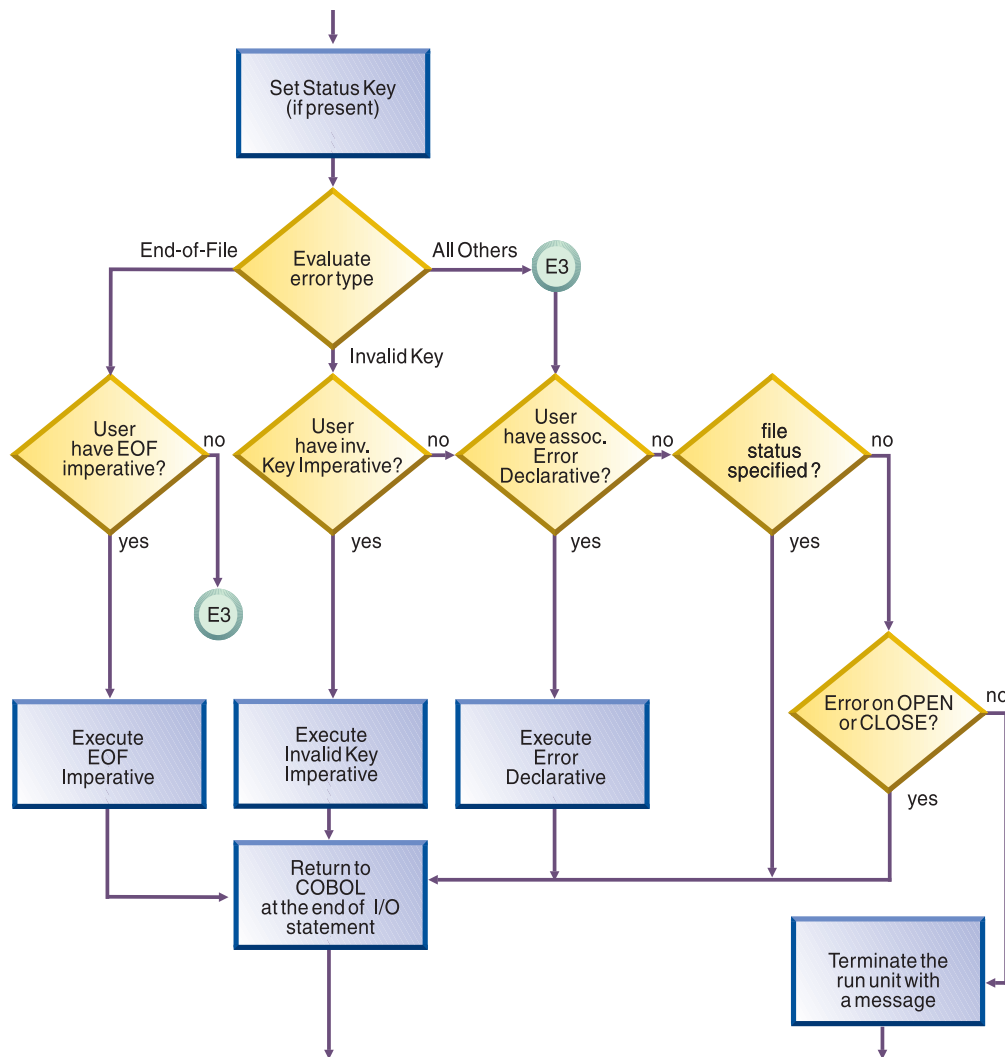

The following figure shows the flow of logic after an input or output error with QSAM or line-sequential files. The error can be from a READ statement, a WRITE statement, or a CLOSE statement with a REEL/UNIT clause (QSAM only).

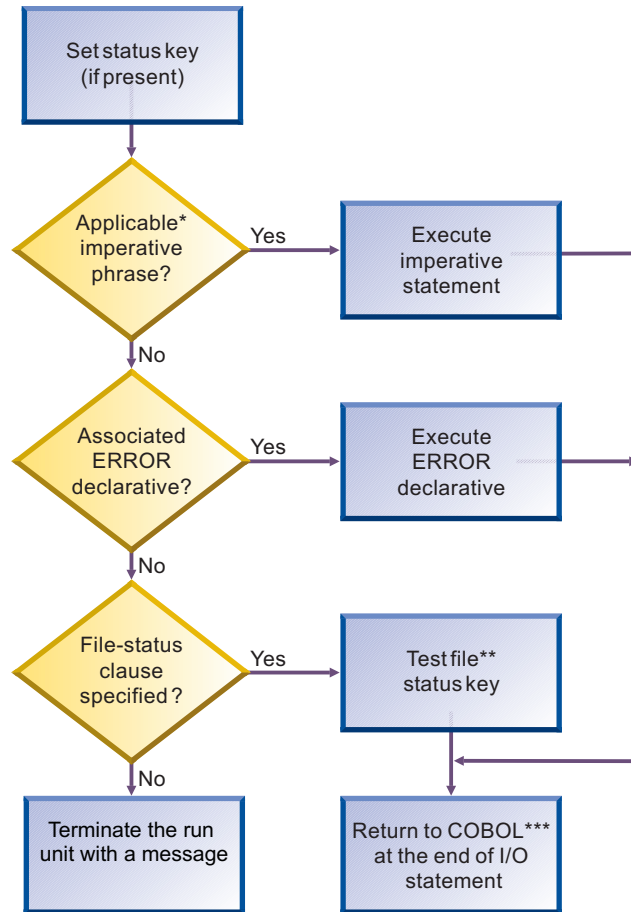

*Possible phrases for QSAM are AT END, AT END-OF-PAGE, and INVALID KEY; for line sequential, AT END.

**You need to write the code to test the file status key.

***Execution of your COBOL program continues after the input or output statement that caused the error.

RELATED TASKS

“Using the end-of-file condition (AT END)”

“Coding ERROR declaratives” on page 244

“Using file status keys” on page 245

“Handling errors in QSAM files” on page 174

“Using VSAM status codes (VSAM files only)” on page 246

“Handling errors in line-sequential files” on page 218

“Coding INVALID KEY phrases” on page 249

RELATED REFERENCES

File status key (*Enterprise COBOL Language Reference*)

Using the end-of-file condition (AT END)

You code the AT END phrase of the READ statement to handle errors or normal conditions, according to your program design. At end-of-file, the AT END phrase is performed. If you do not code an AT END phrase, the associated ERROR declarative is performed.

In many designs, reading sequentially to the end of a file is done intentionally, and the AT END condition is expected. For example, suppose you are processing a file that contains transactions in order to update a master file:

```
PERFORM UNTIL TRANSACTION-EOF = "TRUE"  
  READ UPDATE-TRANSACTION-FILE INTO WS-TRANSACTION-RECORD  
  AT END  
    DISPLAY "END OF TRANSACTION UPDATE FILE REACHED"  
    MOVE "TRUE" TO TRANSACTION-EOF  
  END READ  
  . . .  
END-PERFORM
```

Any NOT AT END phrase is performed only if the READ statement completes successfully. If the READ operation fails because of a condition other than end-of-file, neither the AT END nor the NOT AT END phrase is performed. Instead, control passes to the end of the READ statement after any associated declarative procedure is performed.

You might choose not to code either an AT END phrase or an EXCEPTION declarative procedure, but to code a status key clause for the file instead. In that case, control passes to the next sequential instruction after the input or output statement that detected the end-of-file condition. At that place, have some code that takes appropriate action.

RELATED REFERENCES

AT END phrases (*Enterprise COBOL Language Reference*)

Coding ERROR declaratives

You can code one or more ERROR declarative procedures that will be given control if an input or output error occurs during the execution of your program. If you do not code such procedures, your job could be canceled or abnormally terminated after an input or output error occurs.

Place each such procedure in the declaratives section of the PROCEDURE DIVISION. You can code:

- A single, common procedure for the entire program
- Procedures for each file open mode (whether INPUT, OUTPUT, I-O, or EXTEND)
- Individual procedures for each file

In an ERROR declarative procedure, you can code corrective action, retry the operation, continue, or end execution. (If you continue processing a blocked file, though, you might lose the remaining records in a block after the record that caused the error.) You can use the ERROR declaratives procedure in combination with the file status key if you want a further analysis of the error.

Multithreading: Avoid deadlocks when coding I/O declaratives in multithreaded applications. When an I/O operation results in a transfer of control to an I/O declarative, the automatic serialization lock associated with the file is held during the execution of the statements within the declarative. If you code I/O operations within your declaratives, your logic might result in a deadlock as illustrated by the following sample:

```
Declaratives.  
D1 section.  
Use after standard error procedure on F1  
  Read F2.  
  . . .
```

```

D2 section.
Use after standard error procedure on F2
  Read F1.
  . . .
End declaratives.
  . . .
  Rewrite R1.
  Rewrite R2.

```

When this program is running on two threads, the following sequence of events could occur:

1. Thread 1: Rewrite R1 acquires lock on F1 and encounters I/O error.
2. Thread 1: Enter declarative D1, holding lock on F1.
3. Thread 2: Rewrite R2 acquires lock on F2 and encounters I/O error.
4. Thread 2: Enter declarative D2.
5. Thread 1: Read F2 from declarative D1; wait on F2 lock held by thread 2.
6. Thread 2: Read F1 from declarative D2; wait on F1 lock held by thread 1.
7. Deadlock.

RELATED REFERENCES

EXCEPTION/ERROR declarative (*Enterprise COBOL Language Reference*)

Using file status keys

After each input or output statement is performed on a file, the system updates values in the two digit positions of the file status key. In general, a zero in the first position indicates a successful operation, and a zero in both positions means that nothing abnormal occurred.

Establish a file status key by coding:

- The FILE STATUS clause in the FILE-CONTROL paragraph:
FILE STATUS IS *data-name-1*
- Data definitions in the DATA DIVISION (WORKING-STORAGE, LOCAL-STORAGE, or LINKAGE SECTION), for example:
WORKING-STORAGE SECTION.
01 *data-name-1* PIC 9(2) USAGE NATIONAL.

Specify the file status key *data-name-1* as a two-character category alphanumeric or category national item, or as a two-digit zoned decimal or national decimal item. This *data-name-1* cannot be variably located.

Your program can check the file status key to discover whether an error occurred, and, if so, what type of error occurred. For example, suppose that a FILE STATUS clause is coded like this:

```
FILE STATUS IS FS-CODE
```

FS-CODE is used by COBOL to hold status information like this:

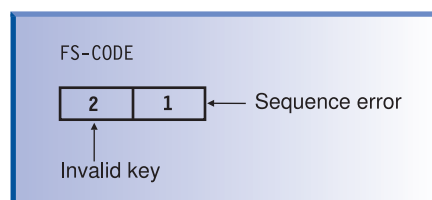

Follow these rules for each file:

- Define a different file status key for each file.
Doing so means that you can determine the cause of a file input or output exception, such as an application logic error or a disk error.
- Check the file status key after each input or output request.
If the file status key contains a value other than 0, your program can issue an error message or can take action based on that value.
You do not have to reset the file status key code, because it is set after each input or output attempt.

For VSAM files, you can additionally code a second identifier in the FILE STATUS clause to get more detailed information about VSAM input or output requests.

You can use the file status key alone or in conjunction with the INVALID KEY phrase, or to supplement the EXCEPTION or ERROR declarative. Using the file status key in this way gives you precise information about the results of each input or output operation.

“Example: file status key”

RELATED TASKS

- “Using VSAM status codes (VSAM files only)”
- “Coding INVALID KEY phrases” on page 249
- “Finding and handling input-output errors” on page 387

RELATED REFERENCES

- FILE STATUS clause (*Enterprise COBOL Language Reference*)
- File status key (*Enterprise COBOL Language Reference*)

Example: file status key

The following example shows how you can perform a simple check of the file status key after opening a file.

```
IDENTIFICATION DIVISION.  
PROGRAM-ID. SIMCHK.  
ENVIRONMENT DIVISION.  
INPUT-OUTPUT SECTION.  
FILE-CONTROL.  
    SELECT MASTERFILE ASSIGN TO AS-MASTERA  
    FILE STATUS IS MASTER-CHECK-KEY  
    . . .  
DATA DIVISION.  
    . . .  
WORKING-STORAGE SECTION.  
01 MASTER-CHECK-KEY      PIC X(2).  
    . . .  
PROCEDURE DIVISION.  
    OPEN INPUT MASTERFILE  
    IF MASTER-CHECK-KEY NOT = "00"  
        DISPLAY "Nonzero file status returned from OPEN " MASTER-CHECK-KEY  
    . . .
```

Using VSAM status codes (VSAM files only)

Often the COBOL file status code is too general to pinpoint the disposition of a request. You can get more detailed information about VSAM input or output requests by coding a second data item in the FILE STATUS clause.

```
FILE STATUS IS data-name-1 data-name-8
```

The data item *data-name-1* shown above specifies the COBOL file status key, which you define as a two-character alphanumeric or national data item, or as a two-digit zoned decimal or national decimal item.

The data item *data-name-8* specifies the VSAM status code, which you define as a 6-byte alphanumeric group data item that has three subordinate 2-byte binary fields. The VSAM status code contains meaningful values when the COBOL file status key is not 0.

You can define *data-name-8* in the WORKING-STORAGE SECTION, as in VSAM-CODE below.

```
01 RETURN-STATUS.
   05 FS-CODE           PIC X(2).
   05 VSAM-CODE.
      10 VSAM-R15-RETURN PIC S9(4) Usage Comp-5.
      10 VSAM-FUNCTION  PIC S9(4) Usage Comp-5.
      10 VSAM-FEEDBACK  PIC S9(4) Usage Comp-5.
```

Enterprise COBOL uses *data-name-8* to pass information supplied by VSAM. In the following example, FS-CODE corresponds to *data-name-1* and VSAM-CODE corresponds to *data-name-8*:

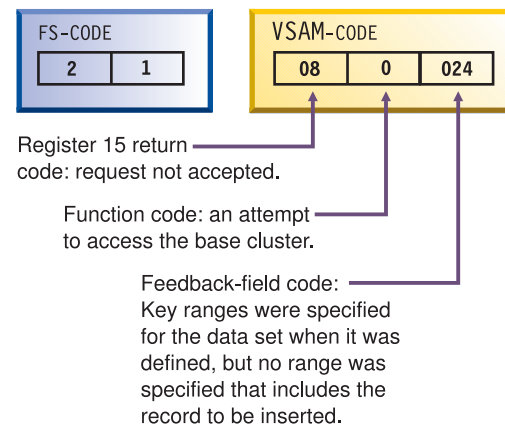

“Example: checking VSAM status codes”

RELATED REFERENCES

FILE STATUS clause (*Enterprise COBOL Language Reference*)

File status key (*Enterprise COBOL Language Reference*)

z/OS DFSMS Macro Instructions for Data Sets (VSAM macro return and reason codes)

Example: checking VSAM status codes

The following example reads an indexed file (starting at the fifth record), checks the file status key after each input or output request, and displays the VSAM status codes when the file status key is not zero.

This example also illustrates how output from this program might look if the file being processed contained six records.

```
IDENTIFICATION DIVISION.
PROGRAM-ID. EXAMPLE.
ENVIRONMENT DIVISION.
INPUT-OUTPUT SECTION.
FILE-CONTROL.
   SELECT VSAMFILE ASSIGN TO VSAMFILE
   ORGANIZATION IS INDEXED
```

```

ACCESS DYNAMIC
RECORD KEY IS VSAMFILE-KEY
FILE STATUS IS FS-CODE VSAM-CODE.
DATA DIVISION.
FILE SECTION.
FD VSAMFILE
RECORD 30.
01 VSAMFILE-REC.
10 VSAMFILE-KEY          PIC X(6).
10 FILLER                 PIC X(24).
WORKING-STORAGE SECTION.
01 RETURN-STATUS.
05 FS-CODE                PIC XX.
05 VSAM-CODE.
10 VSAM-RETURN-CODE      PIC S9(2) Usage Binary.
10 VSAM-COMPONENT-CODE   PIC S9(1) Usage Binary.
10 VSAM-REASON-CODE      PIC S9(3) Usage Binary.
PROCEDURE DIVISION.
OPEN INPUT VSAMFILE.
DISPLAY "OPEN INPUT VSAMFILE FS-CODE: " FS-CODE.

IF FS-CODE NOT = "00"
PERFORM VSAM-CODE-DISPLAY
STOP RUN
END-IF.

MOVE "000005" TO VSAMFILE-KEY.
START VSAMFILE KEY IS EQUAL TO VSAMFILE-KEY.
DISPLAY "START VSAMFILE KEY=" VSAMFILE-KEY
" FS-CODE: " FS-CODE.
IF FS-CODE NOT = "00"
PERFORM VSAM-CODE-DISPLAY
END-IF.

IF FS-CODE = "00"
PERFORM READ-NEXT UNTIL FS-CODE NOT = "00"
END-IF.

CLOSE VSAMFILE.
STOP RUN.

READ-NEXT.
READ VSAMFILE NEXT.
DISPLAY "READ NEXT VSAMFILE FS-CODE: " FS-CODE.
IF FS-CODE NOT = "00"
PERFORM VSAM-CODE-DISPLAY
ELSE
DISPLAY VSAMFILE-REC
END-IF.

VSAM-CODE-DISPLAY.
DISPLAY "VSAM-CODE ==>"
" RETURN: " VSAM-RETURN-CODE,
" COMPONENT: " VSAM-COMPONENT-CODE,
" REASON: " VSAM-REASON-CODE.

```

Below is a sample of the output from the example program that checks VSAM status-code information:

```

OPEN INPUT VSAMFILE FS-CODE: 00
START VSAMFILE KEY=000005 FS-CODE: 00
READ NEXT VSAMFILE FS-CODE: 00
000005 THIS IS RECORD NUMBER 5
READ NEXT VSAMFILE FS-CODE: 00
000006 THIS IS RECORD NUMBER 6
READ NEXT VSAMFILE FS-CODE: 10
VSAM-CODE ==> RETURN: 08 COMPONENT: 2 REASON: 004

```

Coding INVALID KEY phrases

You can include an INVALID KEY phrase in READ, START, WRITE, REWRITE, and DELETE statements for VSAM indexed and relative files. The INVALID KEY phrase is given control if an input or output error occurs due to a faulty index key.

You can also include the INVALID KEY phrase in WRITE requests for QSAM files, but the phrase has limited meaning for QSAM files. It is used only if you try to write to a disk that is full.

Use the FILE STATUS clause with the INVALID KEY phrase to evaluate the status key and determine the specific INVALID KEY condition.

INVALID KEY phrases differ from ERROR declaratives in several ways. INVALID KEY phrases:

- Operate for only limited types of errors. ERROR declaratives encompass all forms.
- Are coded directly with the input or output statement. ERROR declaratives are coded separately.
- Are specific for a single input or output operation. ERROR declaratives are more general.

If you code INVALID KEY in a statement that causes an INVALID KEY condition, control is transferred to the INVALID KEY imperative statement. Any ERROR declaratives that you coded are not performed.

If you code a NOT INVALID KEY phrase, it is performed only if the statement completes successfully. If the operation fails because of a condition other than INVALID KEY, neither the INVALID KEY nor the NOT INVALID KEY phrase is performed. Instead, after the program performs any associated ERROR declaratives, control passes to the end of the statement.

“Example: FILE STATUS and INVALID KEY”

Example: FILE STATUS and INVALID KEY

The following example shows how you can use the file status code and the INVALID KEY phrase to determine more specifically why an input or output statement failed.

Assume that you have a file that contains master customer records and you need to update some of these records with information from a transaction update file. The program reads each transaction record, finds the corresponding record in the master file, and makes the necessary updates. The records in both files contain a field for a customer number, and each record in the master file has a unique customer number.

The FILE-CONTROL entry for the master file of customer records includes statements that define indexed organization, random access, MASTER-CUSTOMER-NUMBER as the prime record key, and CUSTOMER-FILE-STATUS as the file status key.

```
.  
. (read the update transaction record)  
.   
MOVE "TRUE" TO TRANSACTION-MATCH  
MOVE UPDATE-CUSTOMER-NUMBER TO MASTER-CUSTOMER-NUMBER  
READ MASTER-CUSTOMER-FILE INTO WS-CUSTOMER-RECORD  
INVALID KEY
```

```
DISPLAY "MASTER CUSTOMER RECORD NOT FOUND"  
DISPLAY "FILE STATUS CODE IS: " CUSTOMER-FILE-STATUS  
MOVE "FALSE" TO TRANSACTION-MATCH  
END-READ
```

Handling errors when calling programs

When a program dynamically calls a separately compiled program, the called program might be unavailable. For example, the system might be out of storage or unable to locate the program object. If the CALL statement does not have an ON EXCEPTION or ON OVERFLOW phrase, your application might abend.

Use the ON EXCEPTION phrase to perform a series of statements and to perform your own error handling. For example, in the code fragment below, if program REPORTA is unavailable, control passes to the ON EXCEPTION phrase.

```
MOVE "REPORTA" TO REPORT-PROG  
CALL REPORT-PROG  
  ON EXCEPTION  
    DISPLAY "Program REPORTA not available, using REPORTB."  
    MOVE "REPORTB" TO REPORT-PROG  
    CALL REPORT-PROG  
    END-CALL  
END-CALL
```

The ON EXCEPTION phrase applies only to the availability of the called program on its initial load. If the called program is loaded but fails for any other reason (such as initialization), the ON EXCEPTION phrase is not performed.

RELATED TASKS

Enterprise COBOL Migration Guide

Writing routines for handling errors

You can handle most error conditions that might occur while your program is running by using the ON EXCEPTION phrase, ON SIZE ERROR phrase, or other language constructs. But if an extraordinary condition such as a machine check occurs, usually your application is abnormally terminated.

Enterprise COBOL and Language Environment provide a way for a user-written program to gain control when such conditions occur. Using Language Environment condition handling, you can write your own error-handling routines in COBOL. They can report, analyze, or even fix up a program and enable it to resume running.

When you write your own error-handling routines for an application, the COBOL programs must be compiled with appropriate compiler options. For more information, see "OPTIMIZE" on page 346.

To have Language Environment pass control to a user-written error program, you must first identify and register its entry point to Language Environment. PROCEDURE-POINTER data items enable you to pass the entry address of procedure entry points to Language Environment services.

RELATED TASKS

"Using procedure and function pointers" on page 487

RELATED REFERENCES
"OPTIMIZE" on page 346

Part 2. Compiling and debugging your program

Chapter 14. Compiling under z/OS

You can compile Enterprise COBOL programs under z/OS using job control language (JCL), TSO commands, CLISTs, or ISPF panels.

For compiling with JCL, IBM provides a set of cataloged procedures, which can reduce the amount of JCL coding that you need to write. If the cataloged procedures do not meet your needs, you can write your own JCL. Using JCL, you can compile a single program or compile several programs as part of a batch job.

When compiling under TSO, you can use TSO commands, CLISTs, or ISPF panels.

You can also compile in a z/OS UNIX shell by using the `cob2` command.

You might instead want to start the Enterprise COBOL compiler from an assembler program, for example, if your shop has developed a tool or interface that calls the Enterprise COBOL compiler.

As part of the compilation step, you need to define the data sets needed for the compilation and specify any compiler options necessary for your program and the required output.

The compiler translates your COBOL program into language that the computer can process (object code). The compiler also lists errors in your source statements and provides supplementary information to help you debug and tune your program. Use compiler-directing statements and compiler options to control your compilation.

After compiling your program, you need to review the results of the compilation and correct any compiler-detected errors.

RELATED TASKS

“Compiling with JCL”

“Compiling under TSO” on page 262

Chapter 15, “Compiling under z/OS UNIX,” on page 283

“Starting the compiler from an assembler program” on page 265

“Defining compiler input and output” on page 266

“Specifying compiler options under z/OS” on page 272

“Compiling multiple programs (batch compilation)” on page 275

“Correcting errors in your source program” on page 279

RELATED REFERENCES

Chapter 18, “Compiler-directing statements,” on page 381

“Data sets used by the compiler under z/OS” on page 267

“Compiler options and compiler output under z/OS” on page 274

Compiling with JCL

Include the following information in the JCL for compilation: job description, statement to invoke the compiler, and definitions of the needed data sets (including the directory paths of z/OS UNIX files, if any).

The simplest way to compile your program under z/OS is to code JCL that uses a cataloged procedure. A *cataloged procedure* is a set of job control statements in a partitioned data set called the *procedure library* (SYS1.PROCLIB).

The following JCL shows the general format for a cataloged procedure.

```
//jobname JOB parameters
//stepname EXEC [PROC=]procname[, {PARM=|PARM.stepname=} 'options']
//SYSIN DD data-set parameters
. . . (source program to be compiled)
/*
//
```

Additional considerations apply when you use cataloged procedures to compile object-oriented programs.

“Example: sample JCL for a procedural DLL application” on page 510

RELATED TASKS

“Using a cataloged procedure”

“Writing JCL to compile programs” on page 260

“Specifying compiler options under z/OS” on page 272

“Specifying compiler options in a batch compilation” on page 277

“Compiling programs to create DLLs” on page 508

RELATED REFERENCES

“Data sets used by the compiler under z/OS” on page 267

Using a cataloged procedure

Specify a cataloged procedure in an EXEC statement in your JCL.

For example, the following JCL calls the IBM-supplied cataloged procedure IGYWC for compiling an Enterprise COBOL program and defining the required data sets:

```
//JOB1 JOB1
//STEP1 EXEC PROC=IGYWC
//COBOL.SYSIN DD *
000100 IDENTIFICATION DIVISION
        * (the source code)
. . .
/*
```

You can omit /* after the source code. If your source code is stored in a data set, replace SYSIN DD * with appropriate parameters that describe the data set.

You can use these procedures with any of the job schedulers that are part of z/OS. When a scheduler encounters parameters that it does not require, the scheduler either ignores them or substitutes alternative parameters.

If the compiler options are not explicitly supplied with the procedure, default options established at the installation apply. You can override these default options by using an EXEC statement that includes the required options.

You can specify data sets to be in the z/OS UNIX file system by overriding the corresponding DD statement. However, the compiler utility files (SYSUTx) and copy libraries (SYSLIB) you specify must be MVS data sets.

Additional details about invoking cataloged procedures, overriding and adding to EXEC statements, and overriding and adding to DD statements are in the Language Environment information.

RELATED TASKS

Language Environment Programming Guide

RELATED REFERENCES

“Compile procedure (IGYWC)”

“Compile and link-edit procedure (IGYWCL)” on page 258

“Compile, link-edit, and run procedure (IGYWCLG)” on page 259

MVS Program Management: User’s Guide and Reference

Compile procedure (IGYWC)

IGYWC is a single-step cataloged procedure for compiling a program. It produces an object module. The compile steps in all other cataloged procedures that invoke the compiler are similar.

You must supply the following DD statement, indicating the location of the source program, in the input stream:

```
//COBOL.SYSIN DD *          (or appropriate parameters)
```

If you use copybooks in the program that you are compiling, you must also supply a DD statement for SYSLIB or other libraries that you specify in COPY statements. For example:

```
//COBOL.SYSLIB DD DISP=SHR,DSN=DEPT88.BOBS.COBLIB
//IGYWC PROC LNGPRFX='IGY.V5R1M0',
//          LIBPREFIX='CEE'
/**
/** COMPILE A COBOL PROGRAM
/**
/** PARAMETER  DEFAULT VALUE  USAGE
/** LNGPRFX   IGY.V5R1M0      PREFIX FOR LANGUAGE DATA SET NAMES
/** LIBPRFX   CEE              PREFIX FOR LIBRARY DATA SET NAMES
/**
/** CALLER MUST SUPPLY //COBOL.SYSIN DD . . .
/**
/** CALLER MUST ALSO SUPPLY //COBOL.SYSLIB DD . . . for COPY statements
/**
//COBOL EXEC PGM=IGYCRCTL,REGION=0M
//STEPLIB DD DSNAME=&LNGPRFX..SIGYCOMP,DISP=SHR          (1)
//          DD DSNAME=&LIBPREFIX..SCEERUN,DISP=SHR
//          DD DSNAME=&LIBPREFIX..SCEERUN2,DISP=SHR
//SYSPRINT DD SYSOUT=*
//SYSLIN DD DSNAME=&&LOADSET,UNIT=SYSALLDA,
//          DISP=(MOD,PASS),SPACE=(CYL,(1,1)),
//SYSUT1 DD UNIT=SYSALLDA,SPACE=(CYL,(1,1))
//SYSUT2 DD UNIT=SYSALLDA,SPACE=(CYL,(1,1))
//SYSUT3 DD UNIT=SYSALLDA,SPACE=(CYL,(1,1))
//SYSUT4 DD UNIT=SYSALLDA,SPACE=(CYL,(1,1))
//SYSUT5 DD UNIT=SYSALLDA,SPACE=(CYL,(1,1))
//SYSUT6 DD UNIT=SYSALLDA,SPACE=(CYL,(1,1))
//SYSUT7 DD UNIT=SYSALLDA,SPACE=(CYL,(1,1))
//SYSUT8 DD UNIT=SYSALLDA,SPACE=(CYL,(1,1))
//SYSUT9 DD UNIT=SYSALLDA,SPACE=(CYL,(1,1))
//SYSUT10 DD UNIT=SYSALLDA,SPACE=(CYL,(1,1))
//SYSUT11 DD UNIT=SYSALLDA,SPACE=(CYL,(1,1))
//SYSUT12 DD UNIT=SYSALLDA,SPACE=(CYL,(1,1))
//SYSUT13 DD UNIT=SYSALLDA,SPACE=(CYL,(1,1))
//SYSUT14 DD UNIT=SYSALLDA,SPACE=(CYL,(1,1))
//SYSUT15 DD UNIT=SYSALLDA,SPACE=(CYL,(1,1))
//SYSMDECK DD UNIT=SYSALLDA,SPACE=(CYL,(1,1))
```

(1) STEPLIB can be installation-dependent.

“Example: JCL for compiling in the z/OS UNIX file system” on page 258

Example: JCL for compiling in the z/OS UNIX file system:

The following job uses procedure IGYWC to compile a COBOL program, demo.cbl, that is located in the z/OS UNIX file system. The job writes the generated compiler listing demo.lst, object file demo.o, and SYSADATA file demo.adt in the z/OS UNIX file system.

```
//UNIXDEMO JOB ,
// TIME=(1),MSGLEVEL=(1,1),MSGCLASS=H,CLASS=A,REGION=50M,
// NOTIFY=&SYSUID,USER=&SYSUID
//COMPILE EXEC IGYWC,
// PARM.COBOL='LIST,MAP,RENT,FLAG(I,I),XREF,ADATA'
//SYSPRINT DD PATH='/u/userid/cobol/demo.lst',      (1)
// PATHOPTS=(OWRONLY,OCREAT,OTRUNC),             (2)
// PATHMODE=SIRWXU,                               (3)
// FILEDATA=TEXT                                  (4)
//SYSLIN DD PATH='/u/userid/cobol/demo.o',
// PATHOPTS=(OWRONLY,OCREAT,OTRUNC),
// PATHMODE=SIRWXU
//SYSADATA DD PATH='/u/userid/cobol/demo.adt',
// PATHOPTS=(OWRONLY,OCREAT,OTRUNC),
// PATHMODE=SIRWXU
//SYSIN DD PATH='/u/userid/cobol/demo.cbl',
// PATHOPTS=ORDONLY,
// FILEDATA=TEXT,
// RECFM=F
```

- (1) PATH specifies the path name of a file in the z/OS UNIX file system.
- (2) PATHOPTS indicates the access for the file (such as read or read-write) and sets the status for the file (such as append, create, or truncate).
- (3) PATHMODE indicates the permissions, or file access attributes, to be set when a file is created.
- (4) FILEDATA specifies whether the data is to be treated as text or as binary.

You can use a mixture of files in the z/OS UNIX file system (PATH=*unix-directory-path*) and traditional MVS data sets (DSN=*mvs-data-set-name*) in the compilation DD statements (shown in this example as overrides). However, the compiler utility files (DD statements SYSUTx) and COPY libraries (DD statements SYSLIB) must be MVS data sets.

RELATED REFERENCES

"Data sets used by the compiler under z/OS" on page 267

UNIX System Services Command Reference

MVS JCL Reference

Compile and link-edit procedure (IGYWCL)

IGYWCL is a two-step cataloged procedure to compile and link-edit a program.

The COBOL job step produces an object module that is input to the binder (linkage-editor). You can add other object modules. You must supply the following DD statement, indicating the location of the source program, in the input stream:

```
//COBOL.SYSIN DD *      (or appropriate parameters)
```

If the program uses copybooks, you must also supply a DD statement for SYSLIB or other libraries that you specify in COPY statements. For example:

```
//COBOL.SYSLIB DD DISP=SHR,DSN=DEPT88.BOBS.COBLIB
//IGYWCL PROC  LNGPRFX='IGY.V5R1M0',
//             LIBPRFX='CEE',
//             PGMLIB='&&GOSET',GOPGM=GO
```

```

/**
/** COMPILE AND LINK EDIT A COBOL PROGRAM
/**
/** PARAMETER  DEFAULT VALUE  USAGE
/**  LNGPRFX  IGY.V5R1M0      PREFIX FOR LANGUAGE DATA SET NAMES
/**  SYSBLK   3200             BLOCK SIZE FOR OBJECT DATA SET
/**  LIBPRFX  CEE              PREFIX FOR LIBRARY DATA SET NAMES
/**  PGMLIB   &&GOSET          DATA SET NAME FOR LOAD MODULE
/**  GOPGM    GO               MEMBER NAME FOR LOAD MODULE
/**
/** CALLER MUST SUPPLY //COBOL.SYSIN DD . . .
/**
/** CALLER MUST ALSO SUPPLY //COBOL.SYSLIB DD . . . for COPY statements
/**
/**COBOL EXEC PGM=IGYCRCTL,REGION=0M
/**STEPLIB DD DSNAME=&LNGPRFX..SIGYCOMP,DISP=SHR          (1)
//          DD DSNAME=&LIBPRFX..SCEERUN,DISP=SHR
//          DD DSNAME=&LIBPRFX..SCEERUN2,DISP=SHR
/**SYSPRINT DD SYSOUT=*
/**SYSLIN  DD DSNAME=&&LOADSET,UNIT=SYSALLDA,
//          DISP=(MOD,PASS),SPACE=(CYL,(1,1)),
/**SYSUT1  DD UNIT=SYSALLDA,SPACE=(CYL,(1,1))
/**SYSUT2  DD UNIT=SYSALLDA,SPACE=(CYL,(1,1))
/**SYSUT3  DD UNIT=SYSALLDA,SPACE=(CYL,(1,1))
/**SYSUT4  DD UNIT=SYSALLDA,SPACE=(CYL,(1,1))
/**SYSUT5  DD UNIT=SYSALLDA,SPACE=(CYL,(1,1))
/**SYSUT6  DD UNIT=SYSALLDA,SPACE=(CYL,(1,1))
/**SYSUT7  DD UNIT=SYSALLDA,SPACE=(CYL,(1,1))
/**SYSUT8  DD UNIT=SYSALLDA,SPACE=(CYL,(1,1))
/**SYSUT9  DD UNIT=SYSALLDA,SPACE=(CYL,(1,1))
/**SYSUT10 DD UNIT=SYSALLDA,SPACE=(CYL,(1,1))
/**SYSUT11 DD UNIT=SYSALLDA,SPACE=(CYL,(1,1))
/**SYSUT12 DD UNIT=SYSALLDA,SPACE=(CYL,(1,1))
/**SYSUT13 DD UNIT=SYSALLDA,SPACE=(CYL,(1,1))
/**SYSUT14 DD UNIT=SYSALLDA,SPACE=(CYL,(1,1))
/**SYSUT15 DD UNIT=SYSALLDA,SPACE=(CYL,(1,1))
/**SYSMDECK DD UNIT=SYSALLDA,SPACE=(CYL,(1,1))
/**LKED EXEC PGM=IEWBLINK,COND=(8,LT,COBOL),REGION=0M
/**SYSLIB DD DSNAME=&LIBPRFX..SCEELKED,DISP=SHR          (2)
//          DD DSNAME=&LIBPRFX..SCEELKEX,DISP=SHR
/**SYSPRINT DD SYSOUT=*
/**SYSLIN  DD DSNAME=&&LOADSET,DISP=(OLD,DELETE)
//          DD DDNAME=SYSIN
/**SYSLMOD DD DSNAME=&PGMLIB(&GOPGM),
//          SPACE=(CYL,(3,1,1)),
//          UNIT=SYSALLDA,DISP=(MOD,PASS),DSNTYPE=LIBRARY
/**SYSUT1  DD UNIT=SYSALLDA,SPACE=(CYL,(1,1))

```

(1) STEPLIB can be installation-dependent.

(2) SYSLIB can be installation-dependent.

Compile, link-edit, and run procedure (IGYWCLG)

IGYWCLG is a three-step cataloged procedure to compile, link-edit, and run a program.

The COBOL job step produces an object module that is input to the binder (linkage-editor). You can add other object modules. If the COBOL program refers to any data sets, you must also supply DD statements that define these data sets. You must supply the following DD statement, indicating the location of the source program, in the input stream:

```
//COBOL.SYSIN DD *          (or appropriate parameters)
```

If the program uses copybooks, you must also supply a DD statement for SYSLIB or other libraries that you specify in COPY statements. For example:

```

//COBOL.SYSLIB DD DISP=SHR,DSN=DEPT88.BOBS.COBLIB
//IGYWCLG PROC LNGPRFX='IGY.V5R1M0',
//          LIBPRFX='CEE',GOPGM=GO
//*
//*  COMPILER, LINK EDIT AND RUN A COBOL PROGRAM
//*
//*  PARAMETER  DEFAULT VALUE  USAGE
//*  LNGPRFX   IGY.V5R1M0      PREFIX FOR LANGUAGE DATA SET NAMES
//*  LIBPRFX   CEE              PREFIX FOR LIBRARY DATA SET NAMES
//*  GOPGM     GO               MEMBER NAME FOR LOAD MODULE
//*
//*  CALLER MUST SUPPLY //COBOL.SYSIN DD . . .
//*
//*  CALLER MUST ALSO SUPPLY //COBOL.SYSLIB DD . . . for COPY statements
//*
//COBOL EXEC PGM=IGYCRCTL,REGION=0M
//STEPLIB DD DSN=&LNGPRFX..SIGYCOMP,DISP=SHR          (1)
//          DD DSN=&LIBPRFX..SCEERUN,DISP=SHR
//          DD DSN=&LIBPRFX..SCEERUN2,DISP=SHR
//SYSPRINT DD SYSOUT=*
//SYSLIN DD DSN=&&LOADSET,UNIT=SYSALLDA,
//          DISP=(MOD,PASS),SPACE=(CYL,(1,1)),
//SYSUT1 DD UNIT=SYSALLDA,SPACE=(CYL,(1,1))
//SYSUT2 DD UNIT=SYSALLDA,SPACE=(CYL,(1,1))
//SYSUT3 DD UNIT=SYSALLDA,SPACE=(CYL,(1,1))
//SYSUT4 DD UNIT=SYSALLDA,SPACE=(CYL,(1,1))
//SYSUT5 DD UNIT=SYSALLDA,SPACE=(CYL,(1,1))
//SYSUT6 DD UNIT=SYSALLDA,SPACE=(CYL,(1,1))
//SYSUT7 DD UNIT=SYSALLDA,SPACE=(CYL,(1,1))
//SYSUT8 DD UNIT=SYSALLDA,SPACE=(CYL,(1,1))
//SYSUT9 DD UNIT=SYSALLDA,SPACE=(CYL,(1,1))
//SYSUT10 DD UNIT=SYSALLDA,SPACE=(CYL,(1,1))
//SYSUT11 DD UNIT=SYSALLDA,SPACE=(CYL,(1,1))
//SYSUT12 DD UNIT=SYSALLDA,SPACE=(CYL,(1,1))
//SYSUT13 DD UNIT=SYSALLDA,SPACE=(CYL,(1,1))
//SYSUT14 DD UNIT=SYSALLDA,SPACE=(CYL,(1,1))
//SYSUT15 DD UNIT=SYSALLDA,SPACE=(CYL,(1,1))
//SYSMDECK DD UNIT=SYSALLDA,SPACE=(CYL,(1,1))
//LKED EXEC PGM=IEWBLINK,COND=(8,LT,COBOL),REGION=0M
//SYSLIB DD DSN=&LIBPRFX..SCEELKED,DISP=SHR          (2)
//          DD DSN=&LIBPRFX..SCEELKEX,DISP=SHR
//SYSPRINT DD SYSOUT=*
//SYSLIN DD DSN=&&LOADSET,DISP=(OLD,DELETE)
//          DD DDNAME=SYSIN
//SYSLMOD DD DSN=&&GOSET(&GOPGM),SPACE=(CYL,(1,1,1)),
//          UNIT=SYSALLDA,DISP=(MOD,PASS),DSNTYPPE=LIBRARY
//SYSUT1 DD UNIT=SYSALLDA,SPACE=(CYL,(1,1))
//GO EXEC PGM=*.LKED.SYSLMOD,COND=((8,LT,COBOL),(4,LT,LKED)),
//          REGION=0M
//STEPLIB DD DSN=&LIBPRFX..SCEERUN,DISP=SHR          (1)
//          DD DSN=&LIBPRFX..SCEERUN2,DISP=SHR
//SYSPRINT DD SYSOUT=*
//CEEDUMP DD SYSOUT=*
//SYSUDUMP DD SYSOUT=*

```

(1) STEPLIB can be installation-dependent.

(2) SYSLIB can be installation-dependent.

Writing JCL to compile programs

If the cataloged procedures do not provide you with the flexibility that you need for more complex programs, write your own job control statements. The following example shows the general format of JCL used to compile a program.

```

//jobname JOB acctno,name,MSGCLASS=1 (1)
//stepname EXEC PGM=IGYCRCTL,PARM=(options) (2)
//STEPLIB DD DSN=IGY.V5R1M0.SIGYCOMP,DISP=SHR (3)
// DD DSN=SYS1.SCEERUN,DISP=SHR
// DD DSN=SYS1.SCEERUN2,DISP=SHR
//SYSUT1 DD UNIT=SYSALLDA,SPACE=(subparms) (4)
//SYSUT2 DD UNIT=SYSALLDA,SPACE=(subparms)
//SYSUT3 DD UNIT=SYSALLDA,SPACE=(subparms)
//SYSUT4 DD UNIT=SYSALLDA,SPACE=(subparms)
//SYSUT5 DD UNIT=SYSALLDA,SPACE=(subparms)
//SYSUT6 DD UNIT=SYSALLDA,SPACE=(subparms)
//SYSUT7 DD UNIT=SYSALLDA,SPACE=(subparms)
//SYSUT8 DD UNIT=SYSALLDA,SPACE=(subparms)
//SYSUT9 DD UNIT=SYSALLDA,SPACE=(subparms)
//SYSUT10 DD UNIT=SYSALLDA,SPACE=(subparms)
//SYSUT11 DD UNIT=SYSALLDA,SPACE=(subparms)
//SYSUT12 DD UNIT=SYSALLDA,SPACE=(subparms)
//SYSUT13 DD UNIT=SYSALLDA,SPACE=(subparms)
//SYSUT14 DD UNIT=SYSALLDA,SPACE=(subparms)
//SYSUT15 DD UNIT=SYSALLDA,SPACE=(subparms)
//SYSMDECK DD UNIT=SYSALLDA,SPACE=(subparms)
//SYSPRINT DD SYSOUT=A (5)
//SYSLIN DD DSN=MYPROG,UNIT=SYSALLDA, (6)
// DISP=(MOD,PASS),SPACE=(subparms)
//SYSIN DD DSN=dsname,UNIT=device, (7)
// VOLUME=(subparms),DISP=SHR

```

- (1) The JOB statement indicates the beginning of a job.
- (2) The EXEC statement specifies that the Enterprise COBOL compiler (IGYCRCTL) is to be invoked.
- (3) This DD statement defines the data set where the Enterprise COBOL compiler resides.
The Language Environment SCEERUN and SCEERUN2 data sets must be included in the concatenation (together with the compiler SIGYCOMP data set), unless the Language Environment data sets are available in the LNKLIST.
- (4) The SYSUT DD statements define the utility data sets that the compiler will use to process the source program. All SYSUT files must be on direct-access storage devices.
- (5) The SYSPRINT DD statement defines the data set that receives output from compiler options such as LIST and MAP. SYSOUT=A is the standard designation for data sets whose destination is the system output device.
- (6) The SYSLIN DD statement defines the data set (the object module) that receives output from the OBJECT compiler option.
- (7) The SYSIN DD statement defines the data set (source code) to be used as input to the job step.

You can use a mixture of files in the z/OS UNIX file system (PATH='unix-directory-path') and traditional MVS data sets (DSN=mvs-data-set-name) in the compilation DD statements for the following data sets:

- Sources files
- Object files
- Listings
- ADATA files
- Debug files
- Executable modules

However, the compiler utility files (DD statements SYSUTx) and COPY libraries (DD statement SYSLIB) must be MVS data sets.

For more examples about the cataloged procedures in JCL, refer to “Using a cataloged procedure” on page 256 and its child topics.

“Example: user-written JCL for compiling”

“Example: sample JCL for a procedural DLL application” on page 510

RELATED REFERENCES

MVS JCL Reference

MVS Program Management: User's Guide and Reference

Example: user-written JCL for compiling

The following example shows a few possibilities for adapting the basic JCL.

```
//JOB1      JOB                                     (1)
//STEP1    EXEC PGM=IGYCRCTL,PARM='OBJECT'         (2)
//STEPLIB  DD  DSNAME=IGY.V5R1M0.SIGYCOMP,DISP=SHR
//          DD  DSNAME=SYS1.SCEERUN,DISP=SHR
//          DD  DSNAME=SYS1.SCEERUN2,DISP=SHR
//SYSUT1   DD  UNIT=SYSDA,SPACE=(CYL,(1,1))
//SYSUT2   DD  UNIT=SYSDA,SPACE=(CYL,(1,1))
//SYSUT3   DD  UNIT=SYSDA,SPACE=(CYL,(1,1))
//SYSUT4   DD  UNIT=SYSDA,SPACE=(CYL,(1,1))
//SYSUT5   DD  UNIT=SYSDA,SPACE=(CYL,(1,1))
//SYSUT6   DD  UNIT=SYSDA,SPACE=(CYL,(1,1))
//SYSUT7   DD  UNIT=SYSDA,SPACE=(CYL,(1,1))
//SYSUT8   DD  UNIT=SYSALLDA,SPACE=(CYL,(1,1))
//SYSUT9   DD  UNIT=SYSALLDA,SPACE=(CYL,(1,1))
//SYSUT10  DD  UNIT=SYSALLDA,SPACE=(CYL,(1,1))
//SYSUT11  DD  UNIT=SYSALLDA,SPACE=(CYL,(1,1))
//SYSUT12  DD  UNIT=SYSALLDA,SPACE=(CYL,(1,1))
//SYSUT13  DD  UNIT=SYSALLDA,SPACE=(CYL,(1,1))
//SYSUT14  DD  UNIT=SYSALLDA,SPACE=(CYL,(1,1))
//SYSUT15  DD  UNIT=SYSALLDA,SPACE=(CYL,(1,1))
//SYSMDECK DD  UNIT=SYSALLDA,SPACE=(CYL,(1,1))
//SYSPRINT DD  SYSOUT=A
//SYSLIN   DD  DSNAME=MYPROG,UNIT=SYSDA,
//          DISP=(MOD,PASS),SPACE=(TRK,(3,3))
//SYSIN    DD  *                                     (3)
000100 IDENTIFICATION DIVISION.
. . .
/*                                                (4)
```

- (1) JOB1 is the name of the job.
- (2) STEP1 is the name of the sole job step in the job. The EXEC statement also specifies that the generated object code should be placed on disk or tape (to be used as input to the link step).
- (3) The asterisk indicates that the input data set follows in the input stream.
- (4) The delimiter statement /* separates data from subsequent control statements in the input stream.

Compiling under TSO

Under TSO, you can use TSO commands, command lists (CLISTs), REXX execs, or ISPF to compile programs using traditional MVS data sets. You can use TSO commands or REXX execs to compile programs using z/OS UNIX files.

With each method, you need to allocate the data sets and request the compilation:

1. Use the ALLOCATE command to allocate data sets.

For any compilation, allocate the work data sets (SYSUT n) and the SYSIN and SYSPRINT data sets.

If you specify certain compiler options, you must allocate other data sets. For example, if you specify the TERMINAL compiler option, you must allocate the SYSTEM data set to receive compiler messages at your terminal.

You can allocate data sets in any order. However, you must allocate all needed data sets before you start to compile.

2. Use the CALL command at the READY prompt to request compilation:

```
CALL 'IGY.V5R1M0.SIGYCOMP(IGYCRCTL)'
```

You can specify the ALLOCATE and CALL commands on the TSO command line, or, if you are not using z/OS UNIX files, you can include them in a CLIST.

You can allocate z/OS UNIX files for all the compiler data sets except the SYSUT x utility data sets and the SYSLIB libraries. ALLOCATE statements have the following form:

```
Allocate File(SYSIN) Path('/u/myu/myap/std/prog2.cb1')  
Pathopts(ORDONLY) Filedata(TEXT)
```

“Example: ALLOCATE and CALL for compiling under TSO”

“Example: CLIST for compiling under TSO” on page 264

RELATED REFERENCES

“Data sets used by the compiler under z/OS” on page 267

Example: ALLOCATE and CALL for compiling under TSO

The following example shows how to specify ALLOCATE and CALL commands when you are compiling under TSO.

```
[READY]  
ALLOCATE FILE(SYSUT1) CYLINDERS SPACE(1 1)  
[READY]  
ALLOCATE FILE(SYSUT2) CYLINDERS SPACE(1 1)  
[READY]  
ALLOCATE FILE(SYSUT3) CYLINDERS SPACE(1 1)  
[READY]  
ALLOCATE FILE(SYSUT4) CYLINDERS SPACE(1 1)  
[READY]  
ALLOCATE FILE(SYSUT5) CYLINDERS SPACE(1 1)  
[READY]  
ALLOCATE FILE(SYSUT6) CYLINDERS SPACE(1 1)  
[READY]  
ALLOCATE FILE(SYSUT7) CYLINDERS SPACE(1 1)  
[READY]  
ALLOCATE FILE(SYSUT8) CYLINDERS SPACE(1 1)  
[READY]  
ALLOCATE FILE(SYSUT9) CYLINDERS SPACE(1 1)  
[READY]  
ALLOCATE FILE(SYSUT10) CYLINDERS SPACE(1 1)  
[READY]  
ALLOCATE FILE(SYSUT11) CYLINDERS SPACE(1 1)  
[READY]  
ALLOCATE FILE(SYSUT12) CYLINDERS SPACE(1 1)  
[READY]  
ALLOCATE FILE(SYSUT13) CYLINDERS SPACE(1 1)  
[READY]  
ALLOCATE FILE(SYSUT14) CYLINDERS SPACE(1 1)  
[READY]  
ALLOCATE FILE(SYSUT15) CYLINDERS SPACE(1 1)  
[READY]  
ALLOCATE FILE(SYSMDECK) CYLINDERS SPACE(1 1)  
[READY]  
ALLOCATE FILE(SYSPRINT) SYSOUT  
[READY]  
ALLOCATE FILE(SYSTEM) DATASET(*)
```

```

[READY]
ALLOCATE FILE(SYSLIN) DATASET(PROG2.OBJ) NEW TRACKS SPACE(3,3)
[READY]
ALLOCATE FILE(SYSIN) DATASET(PROG2.COBOL) SHR
[READY]
CALL 'IGY.V5R1M0.SIGYCOMP(IGYCRCTL)' 'LIST,NOCOMPILE(S),OBJECT,FLAG(E,E),TERMINAL'
.
(COBOL listings and messages)
.
[READY]
FREE FILE(SYSUT1,SYSUT2,SYSUT3,SYSUT4,SYSUT5,SYSUT6,SYSUT7,SYSUT8,SYSUT9,SYSUT10,SYSUT11,SYSUT12,
SYSUT13,SYSUT14,SYSUT15,SYSMDECK,SYSPRINT,SYSTEM,+
SYSIN,SYSLIN)
[READY]

```

Example: CLIST for compiling under TSO

The following example shows a CLIST for compiling under TSO. The FREE commands are not required. However, good programming practice dictates that you free files before you allocate them.

```

PROC 1 MEM
CONTROL LIST
FREE F(SYSUT1)
FREE F(SYSUT2)
FREE F(SYSUT3)
FREE F(SYSUT4)
FREE F(SYSUT5)
FREE F(SYSUT6)
FREE F(SYSUT7)
FREE F(SYSUT8)
FREE F(SYSUT9)
FREE F(SYSUT10)
FREE F(SYSUT11)
FREE F(SYSUT12)
FREE F(SYSUT13)
FREE F(SYSUT14)
FREE F(SYSUT15)
FREE F(SYSMDECK)
FREE F(SYSPRINT)
FREE F(SYSIN)
FREE F(SYSLIN)
ALLOC F(SYSPRINT) SYSOUT
ALLOC F(SYSIN) DA(COBOL.SOURCE(&MEM)) SHR REUSE
ALLOC F(SYSLIN) DA(COBOL.OBJECT(&MEM)) OLD REUSE
ALLOC F(SYSUT1) NEW SPACE(1,1) CYL UNIT(SYSALLDA)
ALLOC F(SYSUT2) NEW SPACE(1,1) CYL UNIT(SYSALLDA)
ALLOC F(SYSUT3) NEW SPACE(1,1) CYL UNIT(SYSALLDA)
ALLOC F(SYSUT4) NEW SPACE(1,1) CYL UNIT(SYSALLDA)
ALLOC F(SYSUT5) NEW SPACE(1,1) CYL UNIT(SYSALLDA)
ALLOC F(SYSUT6) NEW SPACE(1,1) CYL UNIT(SYSALLDA)
ALLOC F(SYSUT7) NEW SPACE(1,1) CYL UNIT(SYSALLDA)
ALLOC F(SYSUT8) NEW SPACE(1,1) CYL UNIT(SYSALLDA)
ALLOC F(SYSUT9) NEW SPACE(1,1) CYL UNIT(SYSALLDA)
ALLOC F(SYSUT10) NEW SPACE(1,1) CYL UNIT(SYSALLDA)
ALLOC F(SYSUT11) NEW SPACE(1,1) CYL UNIT(SYSALLDA)
ALLOC F(SYSUT12) NEW SPACE(1,1) CYL UNIT(SYSALLDA)
ALLOC F(SYSUT13) NEW SPACE(1,1) CYL UNIT(SYSALLDA)
ALLOC F(SYSUT14) NEW SPACE(1,1) CYL UNIT(SYSALLDA)
ALLOC F(SYSUT15) NEW SPACE(1,1) CYL UNIT(SYSALLDA)
ALLOC F(SYSMDECK) NEW SPACE(1,1) CYL UNIT(SYSALLDA)
CALL 'IGY.V5R1M0.SIGYCOMP(IGYCRCTL)'

```

RELATED REFERENCES

TSO/E Command Reference

Starting the compiler from an assembler program

You can start the Enterprise COBOL compiler from within an assembler program by using the ATTACH or the LINK macro by dynamic invocation. You must identify the compiler options and the ddnames of the data sets to be used during processing.

For example:

```
symbol {LINK|ATTACH} EP=IGYCRCTL,PARAM=(optionlist[,ddnamelist]),VL=1
```

EP Specifies the symbolic name of the compiler. The control program (from the library directory entry) determines the entry point at which the program should begin running.

PARAM Specifies, as a sublist, address parameters to be passed from the assembler program to the compiler.

The first fullword in the address parameter list contains the address of the COBOL *optionlist*. The second fullword contains the address of the *ddnamelist*.

optionlist

Specifies the address of a variable-length list that contains the COBOL options specified for compilation. This address must be written even if no list is provided.

The *optionlist* must begin on a halfword boundary. The 2 high-order bytes contain a count of the number of bytes in the remainder of the list. If no options are specified, the count must be zero. The *optionlist* is freeform, with each field separated from the next by a comma. No blanks or zeros should appear. The compiler recognizes only the first 100 characters.

ddnamelist

Specifies the address of a variable-length list that contains alternative ddnames for the data sets used during compiler processing. If standard ddnames are used, the *ddnamelist* can be omitted.

The *ddnamelist* must begin on a halfword boundary. The 2 high-order bytes contain a count of the number of bytes in the remainder of the list. Each name of less than 8 bytes must be left justified and padded with blanks. If an alternate ddname is omitted from the list, the standard name is assumed. If the name is omitted, the 8-byte entry must contain binary zeros. You can omit names from the end by shortening the list.

All SYSUT n data sets specified must be on direct-access storage devices and have physical sequential organization. They must not reside in the z/OS UNIX file system.

The following table shows the sequence of the 8-byte entries in the *ddnamelist*.

Alternative ddname 8-byte entry	Name for which alternative ddname is substituted
1	SYSLIN
2	Not applicable
3	Not applicable
4	SYSLIB
5	SYSIN
6	SYSPRINT

Alternative ddname 8-byte entry	Name for which alternative ddname is substituted
7	SYSPUNCH
8	SYSUT1
9	SYSUT2
10	SYSUT3
11	SYSUT4
12	SYSTEM
13	SYSUT5
14	SYSUT6
15	SYSUT7
16	SYSADATA
17	SYSJAVA
18	Not applicable
19	SYSMDECK
20	DBRMLIB
21	SYSOPTF
22	SYSUT8
23	SYSUT9
24	SYSUT10
25	SYSUT11
26	SYSUT12
27	SYSUT13
28	SYSUT14
29	SYSUT15

VL Specifies that the sign bit is to be set to 1 in the last fullword of the address parameter list.

When the compiler completes processing, it puts a return code in register 15.

RELATED TASKS

“Defining compiler input and output”

RELATED REFERENCES

“Data sets used by the compiler under z/OS” on page 267

“Compiler options and compiler output under z/OS” on page 274

Defining compiler input and output

You need to define several kinds of data sets that the compiler uses to do its work. The compiler takes input data sets and libraries and produces various types of output, including object code, listings, and messages. The compiler also uses utility data sets during compilation.

RELATED TASKS

“Defining the source code data set (SYSIN)” on page 269

“Defining a compiler-option data set (SYSOPTF)” on page 269

“Specifying source libraries (SYSLIB)” on page 270

“Defining the output data set (SYSRINT)” on page 270
 “Directing compiler messages to your terminal (SYSTEM)” on page 271
 “Creating object code (SYSLIN or SYSPUNCH)” on page 271
 “Defining an associated-data file (SYSADATA)” on page 271
 “Defining the Java-source output file (SYSJAVA)” on page 272
 “Defining the library-processing output file (SYSMDECK)” on page 272

RELATED REFERENCES

“Data sets used by the compiler under z/OS”
 “Compiler options and compiler output under z/OS” on page 274

Data sets used by the compiler under z/OS

The following table lists the function, device requirements, and allowable device classes for each data set that the compiler uses.

Table 34. Compiler data sets

Type	ddname	Function	Required?	Device requirements	Allowable device classes	Can be in z/OS UNIX file system?
Input	SYSIN ¹	Reading source program	Yes	Card reader; intermediate storage	Any	Yes
	SYSOPTF	Reading compiler options	If OPTFILE is in effect	Card reader; intermediate storage; direct access	Any	Yes
	SYSLIB or other copy libraries ¹	Reading user source libraries (PDSs or PDSEs)	If program has COPY or BASIS statements	Direct access	SYSDA	No
Utility ³	SYSUT1, SYSUT2, SYSUT3, SYSUT4, SYSUT6 ²	Work data set used by compiler during compilation	Yes	Direct access	SYSALLDA	No
	SYSUT5 ²	Work data set used by compiler during compilation	If program has COPY, REPLACE, or BASIS statements	Direct access	SYSALLDA	No
	SYSUT7 ²	Work data set used by compiler to create listing	Yes	Direct access	SYSALLDA	No
	SYSUT8, SYSUT9, SYSUT10, SYSUT11, SYSUT12, SYSUT13, SYSUT14, SYSUT15, ²	Work data set used by compiler during compilation	Yes	Direct access	SYSALLDA	No

Table 34. Compiler data sets (continued)

Type	ddname	Function	Required?	Device requirements	Allowable device classes	Can be in z/OS UNIX file system?
Output	SYSPRINT ¹	Writing storage map, listings, and messages	Yes	Printer; intermediate storage	SYSSQ, SYSDA, standard output class A	Yes
	SYSTEM	Writing progress and diagnostic messages	If TERM is in effect	Output device; TSO terminal		Yes
	SYPUNCH	Creating object code	If DECK is in effect	Card punch; direct access	SYSSQ, SYSDA	Yes
	SYSLIN	Creating object module data set as output from compiler and input to binder (linkage-editor)	If OBJECT is in effect	Direct access	SYSSQ, SYSDA	Yes
	SYSADATA ¹	Writing associated data file records	If ADATA is in effect	Output device		Yes
	SYSJAVA	Creating generated Java™ source file for a class definition	If compiling a class definition	(Must be a z/OS UNIX file)		Yes
	SYSUDUMP, SYSABEND, or SYSDUMP	Writing dump	If DUMP is in effect (should be rarely used)	Direct access	SYSDA	Yes
	SYSMDECK	Processing for the MDECK option, or a work data set if NOMDECK is specified.	Yes	Direct access	SYSALLDA	Yes

1. You can use the EXIT option to provide user exits from these data sets.
2. These data sets must be single volume.
3. Do not use DSNTYPE=LARGE for utility data sets (SYSUT1 - SYSUT15).

RELATED REFERENCES

“Logical record length and block size”

“EXIT” on page 324

Logical record length and block size

For compiler data sets other than the work data sets (SYSUT*n*) and z/OS UNIX files, you can set the block size by using the BLKSIZE subparameter of the DCB parameter. The value must be permissible for the device on which the data set resides. The values you set depend on whether the data sets are fixed length or variable length.

For fixed-length records (RECFM=F or RECFM=FB), LRECL is the logical record length; and BLKSIZE equals LRECL multiplied by *n* where *n* is equal to the blocking factor.

The following table shows the defined values for the fixed-length data sets. In general, you should not change these values, but you can change the value for theSYSPRINT data set. You can specify BLKSIZE=0, which results in a system-determined block size.

Table 35. Block size of fixed-length compiler data sets

Data set	RECFM	LRECL (bytes)	BLKSIZE ¹
SYSIN	F or FB	80	80 x <i>n</i>
SYSLIB or other copy libraries	F or FB	80	80 x <i>n</i>
SYSLIN	F or FB	80	80 x <i>n</i>
SYSMDECK	F or FB	80	80 x <i>n</i>
SYSOPTF	F or FB	80	80 x <i>n</i>
SYSPRINT ²	F or FB	133	133 x <i>n</i>
SYSPUNCH	F or FB	80	80 x <i>n</i>
SYSTEM	F or FB	80	80 x <i>n</i>

1. *n* = blocking factor
2. If you specify BLKSIZE=0, the system determines the block size.

For variable-length records (RECFM=V), LRECL is the logical record length, and BLKSIZE equals LRECL plus 4.

Table 36. Block size of variable-length compiler data sets

Data set	RECFM	LRECL (bytes)	BLKSIZE (bytes) minimum acceptable value
SYSADATA	VB	1020	1024

Defining the source code data set (SYSIN)

Define the data set that contains your source code by using the SYSIN DD statement as shown below.

```
//SYSIN DD DSNAME=dsname,UNIT=SYSSQ,VOLUME=(subparms),DISP=SHR
```

You can place your source code or BASIS statement directly in the input stream. To do so, use this SYSIN DD statement:

```
//SYSIN DD *
```

The source code or BASIS statement must follow the DD * statement. If another job step follows the compilation, the EXEC statement for that step must follow the /* statement or the last source statement.

Defining a compiler-option data set (SYSOPTF)

Define a data set that contains the compiler options for your COBOL program by coding the SYSOPTF DD statement as shown below.

```
//SYSOPTF DD DSNAME=dsname,UNIT=SYSDA,VOLUME=(subparms),DISP=SHR
```

To use a compiler-option data set, specify OPTFILE either as a compiler invocation option or in a PROCESS or CBL statement in your source program.

Within the SYSOPTF data set:

- Specify compiler options in free form between columns 2 and 72, using the same syntax as you use for invocation options or for compiler options in a PROCESS or CBL statement.
- Code an asterisk (*) in column 1 to cause a line to be treated as a comment.

- Optionally code sequence numbers in columns 73 through 80; those columns are ignored.

You can optionally place the compiler options directly in the input stream after the SYSOPTF DD statement if you compile using the OPTFILE option:

```
//COB      EXEC PGM=IGYCRCTL,PARM='OPTFILE'
//SYSOPTF  DD DATA,DLM=@@
           SSRANGE ARITH(COMPAT)
           OPTIMIZE
           . . .
@@
//SYSIN    DD . . .
```

You can concatenate multiple SYSOPTF DD statements if you have multiple compiler-option data sets:

```
//SYSOPTF  DD DSNAME=dsname1, . . .
//          DD DSNAME=dsname2, . . .
```

Compiler options that are in later data sets in the concatenation take precedence over options in earlier data sets in the concatenation.

RELATED REFERENCES

“Logical record length and block size” on page 268

“OPTFILE” on page 345

Specifying source libraries (SYSLIB)

Use SYSLIB DD statements if your program contains COPY or BASIS statements. These DD statements define the libraries (partitioned data sets) that contain the data requested by COPY statements in the source code or by BASIS statements in the input stream.

```
//SYSLIB  DD DSNAME=copylibname,DISP=SHR
```

Concatenate multiple DD statements if you have multiple copy or basis libraries:

```
//SYSLIB  DD DSNAME=PROJECT.USERLIB,DISP=SHR
//          DD DSNAME=SYSTEM.COPYX,DISP=SHR
```

Libraries are on direct-access storage devices. They cannot be in the z/OS UNIX file system when you compile with JCL or under TSO.

You do not need the SYSLIB DD statement if the NOLIB option is in effect.

Defining the output data set (SYSPRINT)

You can use ddname SYSPRINT to produce a listing. The listing includes the results of the default or requested options of the PARM parameter (that is, diagnostic messages and the object-code listing).

You can direct the output to a SYSOUT data set, a printer, a direct-access storage device, or a magnetic-tape device. For example:

```
//SYSPRINT DD SYSOUT=A
```

The SYSPRINT data set can be a sequential data set, a PDS or PDSE member, or a z/OS UNIX file. For details about how to specify the record format, record length, and block size of the SYSPRINT data set, see the related reference below.

RELATED REFERENCES

“Logical record length and block size” on page 268

Directing compiler messages to your terminal (SYSTEM)

If you are compiling under TSO, you can define the SYSTEM data set to send compiler messages to your terminal.

```
ALLOC F(SYSTEM) DA(*)
```

You can define SYSTEM in various other ways, for example to a SYSOUT data set, a data set on disk, a file in the z/OS UNIX file system, or to another print class.

Creating object code (SYSLIN or SYSPUNCH)

When using the OBJECT compiler option, you can store the object code on disk as a traditional MVS data set or a z/OS UNIX file, or on tape. The compiler uses the file that you define in the SYSLIN or SYSPUNCH DD statement.

```
//SYSLIN DD DSNAME=dsname,UNIT=SYSDA,  
//          SPACE=(subparms),DISP=(MOD,PASS)
```

Use the DISP parameter of the SYSLIN DD statement to indicate whether the object code data set is to be:

- Passed to the binder (linkage-editor)
- Cataloged
- Kept
- Added to an existing cataloged library

In the example above, the data is created and passed to another job step, the binder (linkage-editor) job step.

Your installation might use the DECK option and the SYSPUNCH DD statement. B is the standard output class for punch data sets:

```
//SYSPUNCH DD SYSOUT=B
```

You do not need the SYSLIN DD statement if the NOOBJECT option is in effect. You do not need the SYSPUNCH DD statement if the NODECK option is in effect.

RELATED REFERENCES

“OBJECT” on page 344

“DECK” on page 319

Defining an associated-data file (SYSADATA)

Define a SYSADATA file if you use the ADATA compiler option.

```
//SYSADATA DD DSNAME=dsname,UNIT=SYSDA
```

The SYSADATA file will be a sequential file that contains specific record types that have information about the program that is collected during compilation. The file can be a traditional MVS data set or a z/OS UNIX file.

RELATED REFERENCES

“ADATA” on page 305

Defining the Java-source output file (SYSJAVA)

Add the SYSJAVA DD statement if you are compiling an OO program. The generated Java source file is written to the SYSJAVA ddname.

```
//SYSJAVA DD PATH='/u/userid/java/Classname.java',  
// PATHOPTS=(OWRONLY,OCREAT,OTRUNC),  
// PATHMODE=SIRWXU,  
// FILEDATA=TEXT
```

The SYSJAVA file must be in the z/OS UNIX file system.

RELATED TASKS

“Compiling OO applications in JCL or TSO/E” on page 295

Defining the library-processing output file (SYSMDECK)

The SYSMDECK data set is required for all compilations. If you specify the MDECK compiler option, the SYSMDECK DD allocation must specify a permanent data set. However, if you use the NOMDECK option, SYSMDECK can be specified as a utility (temporary) data set.

```
//SYSMDECK DD DSNAME=dsname,UNIT=SYSDA
```

The SYSMDECK file will contain a copy of the updated input source after library processing, that is, the result of COPY, BASIS, REPLACE, EXEC SQL INCLUDE, and EXEC SQLIMS INCLUDE statements. The file can be a traditional MVS data set or a z/OS UNIX file.

RELATED REFERENCES

“MDECK” on page 337

Specifying compiler options under z/OS

The compiler is installed with default compiler options. While installing the compiler, the system programmer can fix compiler option settings to, for example, ensure better performance or maintain certain standards. You cannot override any compiler options that are fixed.

For options that are not fixed, you can override the default settings by specifying compiler options in any of these ways:

- Code them on the PROCESS or CBL statement in COBOL source.
- Include them when you start the compiler, either on the PARM parameter on the EXEC statement in the JCL or on the command line under TSO.
- Include them in a SYSOPTF data set, and specify the OPTFILE compiler option in either of the above ways.

The compiler recognizes the options in the following order of precedence from highest to lowest:

1. Installation defaults that are fixed by your site
2. Values of the BUFSIZE, OUTDD, SQL, and SQLIMS compiler options in effect for the first program in a batch
3. Options specified on PROCESS (or CBL) statements, preceding the IDENTIFICATION DIVISION
4. Options specified on the compiler invocation (JCL PARM parameter or the TSO CALL command)
5. Installation defaults that are not fixed

This order of precedence also determines which options are in effect when conflicting or mutually exclusive options are specified.

The precedence of options in a SYSOPTF data set depends on where you specify the OPTFILE compiler option. For example, if you specify OPTFILE in a PROCESS statement, the SYSOPTF options supersede the options that you specify in the compiler invocation. For further details, see the related reference below about the OPTFILE option.

Most of the options come in pairs; you select one or the other. For example, the option pair for a cross-reference listing is XREF | NOXREF. If you want a cross-reference listing, specify XREF; if you do not, specify NOXREF.

Some options have subparameters. For example, if you want 44 lines per page on your listings, specify LINECOUNT(44).

“Example: specifying compiler options using JCL” on page 274

“Example: specifying compiler options under TSO” on page 274

RELATED TASKS

“Defining a compiler-option data set (SYSOPTF)” on page 269

“Specifying compiler options in the PROCESS (CBL) statement”

“Specifying compiler options in a batch compilation” on page 277

RELATED REFERENCES

“Compiler options and compiler output under z/OS” on page 274

Chapter 17, “Compiler options,” on page 301

“Conflicting compiler options” on page 304

“OPTFILE” on page 345

Specifying compiler options in the PROCESS (CBL) statement

Within a COBOL program, you can code most compiler options in PROCESS (CBL) statements. Code the statements before the IDENTIFICATION DIVISION header and before any comment lines or compiler-directing statements.

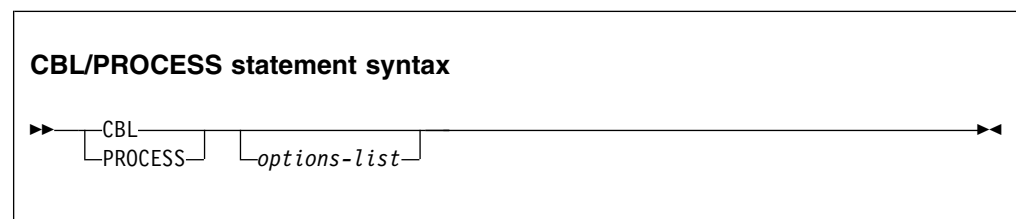

If you do not use a sequence field, you can start a PROCESS statement in column 1 or after. If you use a sequence field, the sequence number must start in column 1 and must contain six characters; the first character must be numeric. If used with a sequence field, PROCESS can start in column 8 or after.

You can use CBL as a synonym for PROCESS. CBL can likewise start in column 1 or after if you do not use a sequence field. If used with a sequence field, CBL can start in column 8 or after.

You must end PROCESS and CBL statements at or before column 72.

Use one or more blanks to separate a PROCESS or CBL statement from the first option in *options-list*. Separate options with a comma or a blank. Do not insert spaces between individual options and their suboptions.

You can code more than one PROCESS or CBL statement. If you do so, the statements must follow one another with no intervening statements. You cannot continue options across multiple PROCESS or CBL statements.

Your programming organization can inhibit the use of PROCESS (CBL) statements by using the default options module of the COBOL compiler. If PROCESS or CBL statements that are not allowed by the organization are found in a COBOL program, the COBOL compiler generates error diagnostics.

RELATED REFERENCES

Reference format (*Enterprise COBOL Language Reference*)

CBL (PROCESS) statement (*Enterprise COBOL Language Reference*)

Example: specifying compiler options using JCL

The following example shows how to specify compiler options under z/OS using JCL.

```

..
//STEP1      EXEC PGM=IGYCRCTL,
//              PARM='LIST,NOCOMPILE(S),OBJECT,FLAG(E,E)'
```

Example: specifying compiler options under TSO

The following example shows how to specify compiler options under TSO.

```

..
[READY]
CALL 'SYS1.LINKLIB(IGYCRCTL)' 'LIST,NOCOMPILE(S),OBJECT,FLAG(E,E)'
```

Compiler options and compiler output under z/OS

When the compiler finishes processing your source program, it will have produced one or more outputs, depending on the compiler options that were in effect.

Table 37. Types of compiler output under z/OS

Compiler option	Compiler output	Type of output
ADATA	Information about the program being compiled	Associated-data file
DLL	Object module that is enabled for DLL support	Object
DUMP	System dump, if compilation ended with abnormal termination (requires SYSUDUMP, SYSABEND, or SYSMDUMP DD statement); should be used rarely	Listing
EXPORTALL	Exported symbols for a DLL	Object
FLAG	List of errors that the compiler found in your program	Listing
LIST	Listing of object code in machine and assembler language	Listing
MAP(HEX) or MAP(DEC)	Map of the data items in your program	Listing
MDECK	Expansion of library-processing statements in your program	Library-processing side file
NUMBER	User-supplied line numbers shown in listing	Listing
OBJECT or DECK with COMPILE	Your object code	Object
OFFSET	Map of the relative addresses in your object code	Listing

Table 37. Types of compiler output under z/OS (continued)

Compiler option	Compiler output	Type of output
OPTIMIZE(1) or OPTIMIZE(2)	Optimized object code	Object
RENT	Reentrant object code	Object
SOURCE	Listing of your source program	Listing
SQL	SQL statements and host variable information for DB2® bind process	Database request module (DBRM)
SSRANGE	Extra code for checking references within tables	In object
TERMINAL	Progress and diagnostic messages sent to terminal	Terminal
TEST	DWARF format debugging information in the object module, to enable interactive debugging	Object
NOTEST(DWARF)	Basic DWARF format diagnostic information, to enable application failure analysis tools	Object
VBREF	Cross-reference listing of verbs in your source program	Listing
XREF	Sorted cross-reference listing of names of procedures, programs, and data	Listing

Listing output from compilation will be in the data set defined by SYSPRINT; object output will be in SYSLIN or SYSPUNCH. Progress and diagnostic messages can be directed to the SYSTEM data set and included in the SYSPRINT data set. The database request module (DBRM) is the data set defined in DBRMLIB.

Save the listings you produced during compilation. You can use them during the testing of your work if you need to debug or tune. You might also use the listings for diagnosis and debugging after the application is in production.

After compilation, fix any errors that the compiler found in your program. If no errors were detected, you can go to the next step in the process: binding (link-editing) your program. (If you used compiler options to suppress object code generation, you must recompile to obtain object code.)

RELATED TASKS

Language Environment Programming Guide (Preparing to link-edit and run)

RELATED REFERENCES

“Messages and listings for compiler-detected errors” on page 280
Chapter 17, “Compiler options,” on page 301

Compiling multiple programs (batch compilation)

You can compile a sequence of separate COBOL programs by using a single invocation of the compiler. You can link the object program produced from this compilation into one program object or separate program objects, controlled by the NAME compiler option.

When you compile several programs as part of a batch job, you need to:

- Determine whether you want to create one or more program objects.
- Terminate each program in the sequence.
- Specify compiler options, with an awareness of the effect of compiler options specified in programs within the batch job.

To create separate program objects, precede each set of objects with the NAME compiler option. When the compiler encounters the NAME option, the first program in the sequence and all subsequent programs until the next NAME compiler option is encountered are link-edited into a single program object. Then each successive program that is compiled with the NAME option is included in a separate program object.

Use the END PROGRAM marker to terminate each program in the sequence except the last program in the batch (for which the END PROGRAM marker is optional). Alternatively, you can precede each program in the sequence with a CBL or PROCESS statement.

If you omit the END PROGRAM marker from a program (other than the last program in a sequence of separate programs), the next program in the sequence will be nested in the preceding program. An error can occur in either of the following situations:

- A PROCESS statement is in a program that is now nested.
- A CBL statement is not coded entirely in the sequence number area (columns 1 through 6).

If a CBL statement is coded entirely in the sequence number area (columns 1 through 6), no error message is issued for the CBL statement because it is considered a label for the source statement line.

“Example: batch compilation”

RELATED TASKS

“Specifying compiler options in a batch compilation” on page 277

RELATED REFERENCES

“NAME” on page 339

Example: batch compilation

The following example shows a batch compilation for three programs (PROG1, PROG2, and PROG3) and the creation of two program objects using one invocation of the IGYWCL cataloged procedure.

The following steps occur:

- PROG1 and PROG2 are link-edited together to form one program object that has the name PROG2. The entry point of this program object defaults to the first program in the program object, PROG1.
- PROG3 is link-edited by itself into a program object that has the name PROG3. Because it is the only program in the program object, the entry point is also PROG3.

```
//jobname JOB acctno,name,MSGLEVEL=1
//stepname EXEC IGYWCL
//COBOL.SYSIN DD *
010100 IDENTIFICATION DIVISION.
010200 PROGRAM-ID PROG1.
      .
      .
019000 END PROGRAM PROG1.
020100 IDENTIFICATION DIVISION.
020200 PROGRAM-ID PROG2.
      .
      .
029000 END PROGRAM PROG2.
      CBL NAME
030100 IDENTIFICATION DIVISION.
```

```

030200 PROGRAM-ID PROG3.
      . . .
039000 END PROGRAM PROG3.
/*
//LKED.SYSLMOD DD DSN=&&GOSET          (1)
/*
//P2          EXEC PGM=PROG2
//STEPLIB DD   DSN=&&GOSET,DISP=(SHR,PASS) (2)
. . . (3)
/*
//P3          EXEC PGM=PROG3
//STEPLIB DD   DSN=&&GOSET,DISP=(SHR,PASS) (2)
. . . (4)
/*
//

```

- (1) The data-set name for the LKED step SYSLMOD is changed to the temporary name &&GOSET, without any member name.
- (2) The temporary data set &&GOSET is used as the STEPLIB for steps P2 and P3 to run the compiled programs. If the Language Environment library does not reside in shared storage, you must also add the library data set as a DD statement for STEPLIB.
- (3) Other DD statements and input that are required to run PROG1 and PROG2 must be added.
- (4) Other DD statements and input that are required to run PROG3 must be added.

RELATED REFERENCES

Language Environment Programming Guide (IBM-supplied cataloged procedures)

Specifying compiler options in a batch compilation

You can specify compiler options for each program in the batch sequence either with a CBL or PROCESS statement that precedes the program, or upon invocation of the compiler.

If a CBL or PROCESS statement is specified in the current program, the compiler resolves the CBL or PROCESS statements together with the options in effect before the first program. If the current program does not contain CBL or PROCESS statements, the compiler uses the settings of options in effect for the previous program.

You should be aware of the effect of certain compiler options on the precedence of compiler option settings for each program in the batch sequence. Compiler options are recognized in the following order of precedence, from highest to lowest:

1. Installation defaults that are fixed at your site
2. Values of the BUFSIZE, OUTDD, SIZE, SQL, and SQLIMS compiler options in effect for the first program in the batch
3. Options on CBL or PROCESS statements, if any, for the current program
4. Options specified in the compiler invocation (JCL PARM or TSO CALL)
5. Installation defaults that are not fixed

If any program in the batch sequence requires the BUF, OUTDD, SIZE, SQL or SQLIMS option, that option must be in effect for the first program in the batch sequence. (When processing BASIS, COPY, or REPLACE statements, the compiler handles all programs in the batch as a single input file.)

If you specify the option for the batch, you cannot change the NUMBER and SEQUENCE options during the batch compilation. The compiler treats all programs in the batch as a single input file during NUMBER and SEQUENCE processing under the option; therefore, the sequence numbers of the entire input file must be in ascending order.

If the compiler diagnoses the LANGUAGE option on the CBL or PROCESS statement as an error, the language selection reverts to what was in effect before the compiler encountered the first CBL or PROCESS statement. The language in effect during a batch compilation conforms to the rules of processing CBL or PROCESS statements in that environment.

“Example: precedence of options in a batch compilation”

“Example: LANGUAGE option in a batch compilation”

Example: precedence of options in a batch compilation

The following example listing shows the precedence of compiler options for batch compilation.

```
PP 5655-W32 IBM Enterprise COBOL for z/OS 5.1.0 Date 03/30/2013. . .
Invocation parameters:
NOTERM
PROCESS(CBL) statements:
CBL CURRENCY,FLAG(I,I)
Options in effect: All options are installation defaults unless otherwise noted:
NOADATA
ADV
QUOTE
ARITH(COMPAT)
NOAWO
NOBLOCK0
BUFSIZE(4096)
. . .
CURRENCY Process option PROGRAM 1
. . .
FLAG(I,I) Process option PROGRAM 1
. . .
NOTERM INVOCATION option
. . .
End of compilation for program 1
. . .
```

```
PP 5655-W32 IBM Enterprise COBOL for z/OS 5.1.0 Date 03/30/2013. . .
PROCESS(CBL) statements:
CBL APOST
Options in effect:
NOADATA
ADV
APOST Process option PROGRAM 2
ARITH(COMPAT)
NOAWO
NOBLOCK0
BUFSIZE(4096)
. . .
NOCURRENCY Installation default option for PROGRAM 2
. . .
FLAG(I) Installation default option
. . .
NOTERM INVOCATION option remains in effect
. . .
End of compilation for program 2
```

Example: LANGUAGE option in a batch compilation

The following example shows the behavior of the LANGUAGE compiler option in a batch environment. The default installation option is ENGLISH (abbreviated EN), and the invocation option is XX, a nonexistent language.

```

CBL LANG(JP),FLAG(I,I),APOST (1)
IDENTIFICATION DIVISION. (2)
PROGRAM-ID. COMPILE1.
. . .
END PROGRAM COMPILE1.
CBL LANGUAGE(YY) (3)
CBL LANGUAGE(JP),LANG(!!) (4)
IDENTIFICATION DIVISION. (2)
PROGRAM-ID. COMPILE2.
. . .
END PROGRAM COMPILE2.
IDENTIFICATION DIVISION.
PROGRAM-ID. COMPILE3.
. . .
END PROGRAM COMPILE3.
CBL LANGUAGE(JP),LANGUAGE(YY) (5)
. . .

```

- (1) The installation default is EN. The invocation option was XX, a nonexistent language. EN is the language in effect.
- (2) After the CBL statement is scanned, JP is the language in effect.
- (3) CBL resets the language to EN. YY is ignored because it is superseded by JP.
- (4) !! is not alphanumeric and is discarded.
- (5) CBL resets the language to EN. YY supersedes JP but is nonexistent.

For the program COMPILE1, the default language English (EN) is in effect when the compiler scans the invocation options. A diagnostic message is issued in mixed-case English because XX is a nonexistent language identifier. The default EN remains in effect when the compiler scans the CBL statement. The unrecognized option APOST in the CBL statement is diagnosed in mixed-case English because the CBL statement has not completed processing and EN was the last valid language option. After the compiler processes the CBL options, the language in effect becomes Japanese (JP).

In the program COMPILE2, the compiler diagnoses CBL statement errors in mixed-case English because English is the language in effect before the first program is used. If more than one LANGUAGE option is specified, only the last valid language specified is used. In this example, the last valid language is Japanese (JP). Therefore Japanese becomes the language in effect when the compiler finishes processing the CBL options. If you want diagnostics in Japanese for the options in the CBL and PROCESS statements, the language in effect before COMPILE1 must be Japanese.

The program COMPILE3 has no CBL statement. It inherits the language in effect, Japanese (JP), from the previous compilation.

After compiling COMPILE3, the compiler resets the language in effect to English (EN) because of the CBL statement. The language option in the CBL statement resolves the last-specified two-character alphanumeric language identifier, YY. Because YY is nonexistent, the language in effect remains English.

Correcting errors in your source program

Messages about source-code errors indicate where the error occurred (LINEID). The text of a message tells you what the problem is. With this information, you can correct the source program.

Although you should try to correct errors, it is not always necessary to correct source code for every diagnostic message. You can leave a warning-level or informational-level message in a program without much risk, and you might decide that the recoding and compilation that are needed to remove the message are not worth the effort. Severe-level and error-level errors, however, indicate probable program failure and should be corrected.

In contrast with the four lower levels of severities, an unrecoverable (U-level) error might not result from a mistake in your source program. It could come from a flaw in the compiler itself or in the operating system. In such cases, the problem must be resolved, because the compiler is forced to end early and does not produce complete object code or a complete listing. If the message occurs for a program that has many S-level syntax errors, correct those errors and compile the program again. You can also resolve job set-up problems (such as missing data-set definitions or insufficient storage for compiler processing) by making changes to the compile job. If your compile job setup is correct and you have corrected the S-level syntax errors, you need to contact IBM to investigate other U-level errors.

After correcting the errors in your source program, recompile the program. If this second compilation is successful, proceed to the link-editing step. If the compiler still finds problems, repeat the above procedure until only informational messages are returned.

RELATED TASKS

“Generating a list of compiler messages”

RELATED REFERENCES

“Messages and listings for compiler-detected errors”

Generating a list of compiler messages

You can generate a complete listing of compiler diagnostic messages with their message numbers, severities, and text by compiling a program that has program-name ERRMSG.

You can code just the PROGRAM-ID paragraph, as shown below, and omit the rest of the program.

```
Identification Division.  
Program-ID. ErrMsg.
```

RELATED TASKS

“Customizing compiler-message severities” on page 720

RELATED REFERENCES

“Messages and listings for compiler-detected errors”

“Format of compiler diagnostic messages” on page 281

Messages and listings for compiler-detected errors

As the compiler processes your source program, it checks for COBOL language errors, and issues diagnostic messages. These messages are collated in the compiler listing (subject to the FLAG option).

Each message in the listing provides information about the nature of the problem, its severity, and the compiler phase that detected it. Wherever possible, the message provides specific instructions for correcting an error.

The messages for errors found during processing of compiler options, CBL and PROCESS statements, and BASIS, COPY, or REPLACE statements are displayed near the top of the listing.

The messages for compilation errors (ordered by line number) are displayed near the end of the listing for each program.

A summary of all problems found during compilation is displayed near the bottom of the listing.

RELATED TASKS

“Correcting errors in your source program” on page 279

“Generating a list of compiler messages” on page 280

RELATED REFERENCES

“Format of compiler diagnostic messages”

“Severity codes for compiler diagnostic messages” on page 282

“FLAG” on page 328

Format of compiler diagnostic messages

Each message issued by the compiler has a source line number, a message identifier, and message text.

Each message has the following form:

nnnnnn IGYppxxx-l message-text

nnnnnn

The number of the source statement of the last line that the compiler was processing. Source statement numbers are listed on the source printout of your program. If you specified the NUMBER option at compile time, the numbers are the original source program numbers. If you specified NONUMBER, the numbers are those generated by the compiler.

IGY A prefix that identifies that the message was issued by the COBOL compiler.

pp Two characters that identify which phase or subphase of the compiler detected the condition that resulted in a message. As an application programmer, you can ignore this information. If you are diagnosing a suspected compiler error, contact IBM for support.

xxx A four-digit number that identifies the message.

l A character that indicates the severity level of the message: I, W, E, S, or U.

message-text

The message text; for an error message, a short explanation of the condition that caused the error.

Tip: If you used the FLAG option to suppress messages, there might be additional errors in your program.

RELATED REFERENCES

“Severity codes for compiler diagnostic messages” on page 282

“FLAG” on page 328

Severity codes for compiler diagnostic messages

Conditions that the compiler can detect fall into five levels or categories of severity.

Table 38. Severity codes for compiler diagnostic messages

Level or category of message	Return code	Purpose
Informational (I)	0	To inform you. No action is required, and the program runs correctly.
Warning (W)	4	To indicate a possible error. The program probably runs correctly as written.
Error (E)	8	To indicate a condition that is definitely an error. The compiler attempted to correct the error, but the results of program execution might not be what you expect. You should correct the error.
Severe (S)	12	To indicate a condition that is a serious error. The compiler was unable to correct the error. The program does not run correctly, and execution should not be attempted. Object code might not be created.
Unrecoverable (U)	16	To indicate an error condition of such magnitude that the compilation was terminated.

The final return code at the end of compilation is generally the highest return code that occurred for any message during the compilation.

You can suppress compiler diagnostic messages or change their severities, however, which can have an effect upon the final compilation return code. For details, see the related information.

RELATED TASKS

“Customizing compiler-message severities” on page 720

RELATED REFERENCES

“Processing of MSGEXIT” on page 719

Chapter 15. Compiling under z/OS UNIX

Compile Enterprise COBOL programs under z/OS UNIX by using the `cob2` command. Under z/OS UNIX, you can compile any COBOL program that you can compile under z/OS. The object code generated by the COBOL compiler can run under z/OS.

As part of the compilation step, you define the files needed for the compilation, and specify any compiler options or compiler-directing statements that are necessary for your program and for the output that you want.

The main job of the compiler is to translate COBOL programs into language that the computer can process (object code). The compiler also lists errors in source statements and provides supplementary information to help you debug and tune programs.

RELATED TASKS

“Setting environment variables under z/OS UNIX”

“Specifying compiler options under z/OS UNIX” on page 284

“Compiling and linking with the `cob2` command” on page 285

“Compiling using scripts” on page 289

“Compiling, linking, and running OO applications under z/OS UNIX” on page 291

RELATED REFERENCES

“Data sets used by the compiler under z/OS” on page 267

“Compiler options and compiler output under z/OS” on page 274

Setting environment variables under z/OS UNIX

An *environment variable* is a name that is associated with a string of characters and that defines some variable aspect of the program environment. You use environment variables to set values that programs, including the compiler, need.

Set the environment variables for the compiler by using the `export` command. For example, to set the `SYSLIB` variable, issue the `export` command from the shell or from a script file:

```
export SYSLIB=/u/mystuff/copybooks
```

The value that you assign to an environment variable can include other environment variables or the variable itself. The values of these variables apply only when you compile from the shell where you issue the `export` command. If you do not set an environment variable, either a default value is applied or the variable is not defined. The environment-variable names must be uppercase.

The environment variables that you can set for use by the compiler are as follows:

COBOPT

Specify compiler options separated by blanks or commas. Separate suboptions with commas. Blanks at the beginning or the end of the variable value are ignored. Delimit the list of options with quotation marks if it contains blanks or characters that are significant to the z/OS UNIX shell. For example:

```
export COBOPT="TRUNC(OPT) XREF"
```

SYSLIB

Specify paths to directories to be used in searching for COBOL copybooks if you do not specify an explicit library-name in the COPY statement. Separate multiple paths with a colon. Paths are evaluated in order from the first path to the last in the export command. If you set the variable with multiple files of the same name, the first located copy of the file is used.

For COPY statements in which you have not coded an explicit library-name, the compiler searches for copybooks in this order:

1. In the current directory
2. In the paths you specify with the `-I cob2` option
3. In the paths you specify in the SYSLIB environment variable

library-name

Specify the directory path from which to copy when you specify an explicit library-name in the COPY statement. The environment-variable name is identical to the *library-name* in your program. You must set an environment variable for each library; an error will occur otherwise. The environment-variable name *library-name* must be uppercase.

text-name

Specify the name of the file from which to copy text. The environment-variable name is identical to the *text-name* in your program. The environment-variable name *text-name* must be uppercase.

RELATED TASKS

“Specifying compiler options under z/OS UNIX”

“Compiling and linking with the cob2 command” on page 285

“Setting and accessing environment variables” on page 464

RELATED REFERENCES

Chapter 18, “Compiler-directing statements,” on page 381

Chapter 17, “Compiler options,” on page 301

COPY statement (*Enterprise COBOL Language Reference*)

Specifying compiler options under z/OS UNIX

The compiler is installed and set up with default compiler options. While installing the compiler, a system programmer can fix compiler option settings to ensure better performance or maintain certain standards. You cannot override any compiler options that your site has fixed.

For options that are not fixed, you can override the default settings by specifying compiler options in any of three ways:

- Code them on the PROCESS or CBL statement in your COBOL source.
- Specify the `-q` option of the cob2 command.
- Set the COBOPT environment variable.

The compiler recognizes the options in the above order of precedence, from highest to lowest. The order of precedence also determines which options are in effect when conflicting or mutually exclusive options are specified. When you compile using the cob2 command, compiler options are recognized in the following order of precedence, from highest to lowest:

1. Installation defaults fixed as nonoverridable

2. The values of BUFSIZE, SQL, SQLIMS, and OUTDD options in effect for the first program in a batch compilation
3. The values that you specify on PROCESS or CBL statements in COBOL source programs
4. The values that you specify in the cob2 command's -q option string
5. The values that you specify in the COBOPT environment variable
6. Installation defaults that are not fixed

Restrictions:

- Do not use the SQL compiler option under z/OS UNIX.
Neither the separate SQL precompiler nor the integrated SQL coprocessor runs under z/OS UNIX.
- Do not use the SQLIMS compiler option under z/OS UNIX.
- The OPTFILE option is ignored when you compile using the cob2 command under z/OS UNIX.
You can use the COBOPT environment variable, which provides a capability that is comparable to OPTFILE, instead.

RELATED TASKS

- “Specifying compiler options in the PROCESS (CBL) statement” on page 273
- “Setting environment variables under z/OS UNIX” on page 283
- “Compiling and linking with the cob2 command”

RELATED REFERENCES

- “Conflicting compiler options” on page 304
- Chapter 17, “Compiler options,” on page 301

Compiling and linking with the cob2 command

Use the cob2 command to compile and link COBOL programs from the z/OS UNIX shell. You can specify the options and input file-names in any order, using spaces to separate options and names. Any options that you specify apply to all files on the command line.

To compile multiple files (batch compilation), specify multiple source-file names.

When you compile COBOL programs for z/OS UNIX, the RENT option is required. The cob2 command automatically includes the COBOL compiler options RENT and TERM.

The cob2 command invokes the COBOL compiler that is found through the standard MVS search order. If the COBOL compiler is not installed in the LNKLST, or if more than one level of IBM COBOL compiler is installed on your system, you can specify in the STEPLIB environment variable the compiler PDS that you want to use. For example, the following statement specifies IGY.V5R1M0 as the compiler PDS:

```
export STEPLIB=IGY.V5R1M0.SIGYCOMP
```

The cob2 command implicitly uses the z/OS UNIX shell command c89 for the link step. c89 is the shell interface to the linker (the z/OS program management binder).

The default location for compiler input and output is the current directory.

Only files with the suffix `.cbl` are passed to the compiler; `cob2` passes all other files to the linker.

The listing output that you request from the compilation of a COBOL source program `file.cbl` is written to `file.lst`. The listing output that you request from the linker is written to `stdout`.

The linker causes execution to begin at the first main program.

RELATED TASKS

“Creating a DLL under z/OS UNIX”

“Preparing OO applications under z/OS UNIX” on page 292
UNIX System Services User’s Guide

RELATED REFERENCES

“cob2 syntax and options” on page 287

“cob2 input and output files” on page 288
UNIX System Services Command Reference

Creating a DLL under z/OS UNIX

To create a DLL from the z/OS UNIX shell, you must specify the `cob2` option `-bdll`.

```
cob2 -o mydll -bdll mysub.cbl
```

When you specify `cob2 -bdll`:

- The COBOL compiler uses the compiler options `DLL`, `EXPORTALL`, and `RENT`, which are required for DLLs.
- The link step produces a DLL definition side file that contains `IMPORT` control statements for each of the names exported by the DLL.

The name of the DLL definition side file is based on the output file-name. If the output name has a suffix, that suffix is replaced with `x` to form the side-file name. For example, if the output file-name is `foo.dll`, the side-file name is `foo.x`.

To use the DLL definition side file later when you create a module that calls that DLL, specify the side file with any other object files (`file.o`) that you need to link. For example, the following command compiles `myapp1.cbl`, uses the `DLL` option to enable `myapp1.o` to reference DLLs, and links to produce the module `myapp1`:

```
cob2 -o myapp1 -qdll myapp1.cbl mydll.x
```

“Example: using `cob2` to compile and link under z/OS UNIX”

RELATED TASKS

Chapter 26, “Creating a DLL or a DLL application,” on page 507

“Compiling programs to create DLLs” on page 508

RELATED REFERENCES

“cob2 syntax and options” on page 287

“cob2 input and output files” on page 288

Example: using `cob2` to compile and link under z/OS UNIX

The following examples illustrate the use of `cob2`.

- To compile one file called `alpha.cbl`, enter:

```
cob2 -c alpha.cbl
```

The compiled file is named alpha.o.

- To compile two files called alpha.cbl and beta.cbl, enter:

```
cob2 -c alpha.cbl beta.cbl
```

The compiled files are named alpha.o and beta.o.

- To link two files, compile them without the -c option. For example, to compile and link alpha.cbl and beta.cbl and generate gamma, enter:

```
cob2 alpha.cbl beta.cbl -o gamma
```

This command creates alpha.o and beta.o, then links alpha.o, beta.o, and the COBOL libraries. If the link step is successful, it produces an executable program named gamma.

- To compile alpha.cbl with the LIST and NODATA options, enter:

```
cob2 -qlist,noadata alpha.cbl
```

cob2 syntax and options

You can use the options listed below with the cob2 command. (Do not capitalize cob2.)

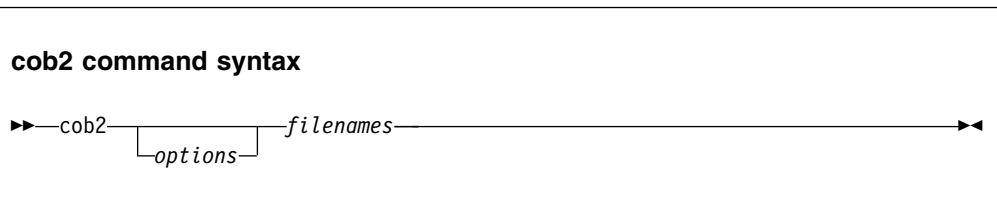

- bx** Passes the string *xxx* to the linker as parameters. *xxx* is a list of linker options in *name=value* format, separated by commas. You must spell out both the name and the value in full (except for the special cases noted below). The name and value are case insensitive. Do not use any spaces between -b and *xxx*.

If you do not specify a value for an option, a default value of YES is used except for the following options, which have the indicated default values:

- LIST=NOIMPORT
- ALIASES=ALL
- COMPAT=CURRENT
- DYNAM=DLL

One special value for *xxx* is *dll*, which specifies that the executable module is to be a DLL. This string is not passed to the linker.

- c** Compiles programs but does not link them.

-comprc_ok=*n*

Controls cob2 behavior on the return code from the compiler. If the return code is less than or equal to *n*, cob2 continues to the link step or, in the compile-only case, exits with a zero return code. If the return code returned by the compiler is greater than *n*, cob2 exits with the same return code. When the c89 command is implicitly invoked by cob2 for the link step, the exit value from the c89 command is used as the return code from the cob2 command.

The default is -comprc_ok=4.

- e** *xxx* Specifies the name of the program to be used as the entry point of the

module. The program must be one of the programs that will be included in the module. If you do not specify `-e`, the default entry point is the first program (*file.cbl*) or object file (*file.o*) that you specify as a file name on the `cob2` command invocation.

- g** Prepares the program for debugging. Equivalent to specifying the `TEST` option with no suboptions.
- Ixxx** Adds a path *xxx* to the directories to be searched for copybooks for which you do not specify a *library-name*.

To specify multiple paths, either use multiple `-I` options, or use a colon to separate multiple path names within a single `-I` option value.

For `COPY` statements in which you have not coded an explicit *library-name*, the compiler searches for copybooks in the following order:
 1. In the current directory
 2. In the paths you specify with the `-I cob2` option
 3. In the paths you specify in the `SYSLIB` environment variable
- L xxx** Specifies the directory paths to be used to search for archive libraries specified by the `-l` operand.
- l xxx** Specifies the name of an archive library for the linker. The `cob2` command searches for the name `libxxx.a` in the directories specified in the `-L` option, then in the usual search order. (This option is lowercase *l*, not uppercase *L*.)
- o xxx** Names the object module *xxx*. If the `-o` option is not used, the name of the object module is `a.out`.
- qxxx** Passes *xxx* to the compiler, where *xxx* is a list of compiler options separated by blanks or commas.

Enclose *xxx* in quotation marks if a parenthesis is part of the option or suboption, or if you use blanks to separate options. Do not insert spaces between `-q` and *xxx*.
- v** Displays the generated commands that are issued by `cob2` for the compile and link steps, including the options being passed, and executes them.
Here is sample output:

```
cob2 -v -o mini -qssrange mini.cbl
compiler: ATTCRCTL PARM=RENT,TERM,SSRANGE /u/userid/cobol/mini.cbl
PP 5655-W32 IBM Enterprise COBOL for z/OS 5.1.0 in progress ...
End of compilation 1, program mini, no statements flagged.
linker: /bin/c89 -o mini -e // mini.o
```
- #** Displays compile and link steps, but does not execute them.

RELATED TASKS

“Compiling and linking with the `cob2` command” on page 285

“Creating a DLL under z/OS UNIX” on page 286

“Setting environment variables under z/OS UNIX” on page 283

cob2 input and output files

You can specify the following files as input file-names when you use the `cob2` command.

Table 39. Input files to the cob2 command

File name	Description	Comments
<i>file.cbl</i>	COBOL source file to be compiled and linked	Will not be linked if you specify the cob2 option -c
<i>file.a</i>	Archive file	Produced by the ar command, to be used during the link-edit phase
<i>file.o</i>	Object file to be link-edited	Can be produced by the COBOL compiler, the C/C++ compiler, or the assembler
<i>file.x</i>	DLL definition side file	Used during the link-edit phase of an application that references the dynamic link library (DLL)

If you use the cob2 command, the following files are created in the current directory.

Table 40. Output files from the cob2 command

File name	Description	Comments
<i>file</i>	Executable module or DLL	Created by the linker if you specify the cob2 option -o <i>file</i>
<i>a.out</i>	Executable module or DLL	Created by the linker if you do not specify the cob2 option -o
<i>file.adt</i>	Associated data (ADATA) file corresponding to input COBOL source program <i>file.cbl</i>	Created by the compiler if you specify compiler option ADATA
<i>file.dek</i>	Extended COBOL source output from library processing	Created by the compiler if you specify compiler option MDECK
<i>file.lst</i>	Listing file corresponding to input COBOL source program <i>file.cbl</i>	Created by the compiler
<i>file.o</i>	Object file corresponding to input COBOL source program <i>file.cbl</i>	Created by the compiler
<i>file.x</i>	DLL definition side file	Created during the cob2 linking phase when creating <i>file.dll</i>
<i>class.java</i>	Java class definition (source)	Created when you compile a class definition

RELATED TASKS

“Compiling and linking with the cob2 command” on page 285

RELATED REFERENCES

“ADATA” on page 305

“MDECK” on page 337

“TEST” on page 364

UNIX System Services Command Reference

Compiling using scripts

If you use a shell script to automate cob2 tasks, you must code option syntax carefully to prevent the shell from passing invalid strings to cob2.

Code option strings in scripts as follows:

|
|

- Use an equal sign and colon rather than a left and right parenthesis, respectively, to specify compiler suboptions. For example, code `-qOPTIMIZE=1: ,XREF` instead of `-qOPTIMIZE(1) ,XREF`.
- Use an underscore rather than a single quotation mark where a compiler option requires single quotation marks for delimiting a suboption.
- Do not use blanks in the option string.

Chapter 16. Compiling, linking, and running OO applications

It is recommended that you compile, link, and run object-oriented (OO) applications in the z/OS UNIX environment. However, with certain limitations explained in the related tasks, it is possible to compile, link, and run OO COBOL applications by using standard batch JCL or TSO/E commands.

RELATED TASKS

- “Compiling, linking, and running OO applications under z/OS UNIX”
- “Compiling, linking, and running OO applications in JCL or TSO/E” on page 295
- “Using Java SDKs for z/OS” on page 299

Compiling, linking, and running OO applications under z/OS UNIX

When you compile, link, and run object-oriented applications in a z/OS UNIX environment, application components reside in the z/OS UNIX file system. You compile and link them by using shell commands, and run them at a shell command prompt or with the BPXBATCH utility from JCL or TSO/E.

RELATED TASKS

- “Compiling OO applications under z/OS UNIX”
- “Preparing OO applications under z/OS UNIX” on page 292
- “Running OO applications under z/OS UNIX” on page 293

Compiling OO applications under z/OS UNIX

When you compile OO applications in a z/OS UNIX shell, use the `cob2` command to compile COBOL client programs and class definitions, and the `javac` command to compile Java class definitions to produce *bytecode* (suffix `.class`).

To compile COBOL source code that contains OO syntax such as `INVOKE` statements or class definitions, or that uses Java services, you must use these compiler options: `RENT`, `DLL`, `THREAD`, and `DBCS`. (The `RENT` and `DBCS` options are defaults.)

A COBOL source file that contains a class definition must not contain any other class or program definitions.

When you compile a COBOL class definition, two output files are generated:

- The object file (`.o`) for the class definition.
- A Java source program (`.java`) that contains a class definition that corresponds to the COBOL class definition. Do not edit this generated Java class definition in any way. If you change the COBOL class definition, you must regenerate both the object file and the Java class definition by recompiling the updated COBOL class definition.

If a COBOL client program or class definition includes the file `JNI.cpy` by using a `COPY` statement, specify the include subdirectory of the COBOL install directory (typically `/usr/lpp/cobol/include`) in the search order for copybooks. You can specify the include subdirectory by using the `-I` option of the `cob2` command or by setting the `SYSLIB` environment variable.

RELATED TASKS

- Chapter 15, “Compiling under z/OS UNIX,” on page 283

“Preparing OO applications under z/OS UNIX”
 “Running OO applications under z/OS UNIX” on page 293
 “Setting and accessing environment variables” on page 464
 “Accessing JNI services” on page 633

RELATED REFERENCES

“cob2 syntax and options” on page 287
 “DBCS” on page 319
 “DLL” on page 321
 “RENT” on page 352
 “THREAD” on page 366

Preparing OO applications under z/OS UNIX

Use the cob2 command to link OO COBOL applications.

To prepare an OO COBOL client program for execution, link the object file with the following two DLL side files to create an executable module:

- libjvm.x, which is provided with your IBM Java Software Development Kit.
- igzcjava.x, which is provided in the lib subdirectory of the cobol directory in the z/OS UNIX file system. The typical complete path is /usr/lpp/cobol/lib/igzcjava.x. This DLL side file is also available as the member IGZCJAVA in the SCEELIB PDS (part of Language Environment).

To prepare a COBOL class definition for execution:

1. Link the object file using the two DLL side files mentioned above to create an executable DLL module.
 You must name the resulting DLL module lib*Classname*.so, where *Classname* is the external class-name. If the class is part of a package and thus there are periods in the external class-name, you must change the periods to underscores in the DLL module name. For example, if class Account is part of the com.acme package, the external class-name (as defined in the REPOSITORY paragraph entry for the class) must be com.acme.Account, and the DLL module for the class must be libcom_acme_Account.so.
2. Compile the generated Java source with the Java compiler to create a class file (.class).

For a COBOL source file *Classname*.cbl that contains the class definition for *Classname*, you would use the following commands to compile and link the components of the application:

Table 41. Commands for compiling and linking a class definition

Command	Input	Output
cob2 -c -qdll,thread <i>Classname</i> .cbl	<i>Classname</i> .cbl	<i>Classname</i> .o, <i>Classname</i> .java
cob2 -bdll -o lib <i>Classname</i> .so <i>Classname</i> .o /usr/lpp/java/J5.0/bin/j9vm/libjvm.x /usr/lpp/cobol/lib/igzcjava.x	<i>Classname</i> .o	lib <i>Classname</i> .so
javac <i>Classname</i> .java	<i>Classname</i> .java	<i>Classname</i> .class

After you issue the cob2 and javac commands successfully, you have the executable components for the program: the executable DLL module lib*Classname*.so and the class file *Classname*.class. All files from these commands are generated in the current working directory.

“Example: compiling and linking a COBOL class definition under z/OS UNIX”

RELATED TASKS

Chapter 15, “Compiling under z/OS UNIX,” on page 283
“REPOSITORY paragraph for defining a class” on page 594

RELATED REFERENCES

“cob2 syntax and options” on page 287
“Object-oriented syntax, and Java 6, Java 7, or Java 8” on page 300

Example: compiling and linking a COBOL class definition under z/OS UNIX

This example illustrates the commands that you use and the files that are produced when you compile and link a COBOL class definition, `Manager.cbl`, using z/OS UNIX shell commands.

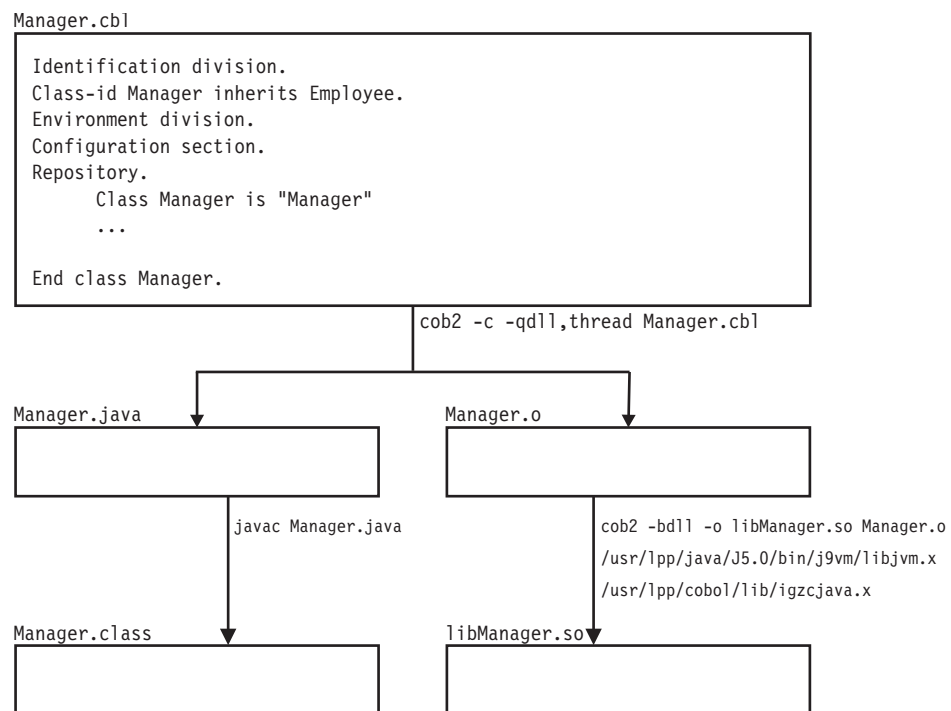

The class file `Manager.class` and the DLL module `libManager.so` are the executable components of the application, and are generated in the current working directory.

Running OO applications under z/OS UNIX

It is recommended that you run object-oriented COBOL applications as z/OS UNIX applications. You must do so if an application begins with a Java program or the main factory method of a COBOL class.

Specify the directory that contains the DLLs for the COBOL classes in the `LIBPATH` environment variable. Specify the directory paths for the Java class files that are associated with the COBOL classes in the `CLASSPATH` environment variable as follows:

- For classes that are not part of a package, end the class path with the directory that contains the `.class` files.

- For classes that are part of a package, end the class path with the directory that contains the "root" package (the first package in the full package name).
- For a .jar file that contains .class files, end the class path with the name of the .jar file.

Separate multiple path entries with colons.

RELATED TASKS

- “Running OO applications that start with a main method”
- “Running OO applications that start with a COBOL program”
- “Running J2EE COBOL clients” on page 295
- Chapter 23, “Running COBOL programs under z/OS UNIX,” on page 463
- “Setting and accessing environment variables” on page 464
- Chapter 30, “Writing object-oriented programs,” on page 589
- “Structuring OO applications” on page 630

Running OO applications that start with a main method

If the first routine of a mixed COBOL and Java application is the main method of a Java class or the main factory method of a COBOL class, run the application by using the java command and by specifying the name of the class that contains the main method.

The java command initializes the Java virtual machine (JVM). To customize the initialization of the JVM, specify options on the java command as in the following examples:

Table 42. java command options for customizing the JVM

Purpose	Option
To set a system property	-Dname=value
To request that the JVM generate verbose messages about garbage collection	-verbose:gc
To request that the JVM generate verbose messages about class loading	-verbose:class
To request that the JVM generate verbose messages about native methods and other Java Native Interface activity	-verbose:jni
To set the initial Java heap size to value bytes	-Xmsvalue
To set the maximum Java heap size to value bytes	-Xmxvalue

For details about the options that the JVM supports, see the output from the java -h command, or see the related references.

RELATED REFERENCES

- IBM SDK, Java Technology Edition
- WebSphere for z/OS: Applications (Java Naming and Directory Interface (JNDI))

Running OO applications that start with a COBOL program

If the first routine of a mixed COBOL and Java application is a COBOL program, run the application by specifying the program name at the command prompt. If a JVM is not already running in the process of the COBOL program, the COBOL run time automatically initializes a JVM.

To customize the initialization of the JVM, specify options by setting the COBJVMINITOPTIONS environment variable. Use blanks to separate options. For example:

```
export COBJVMINITOPTIONS="-Xms10000000 -Xmx20000000 -verbose:gc"
```

RELATED TASKS

"Using Java SDKs for z/OS" on page 299

Chapter 23, "Running COBOL programs under z/OS UNIX," on page 463

"Setting and accessing environment variables" on page 464

RELATED REFERENCES

IBM SDK, Java Technology Edition

WebSphere for z/OS: Applications (Java Naming and Directory Interface (JNDI))

Running J2EE COBOL clients:

You can use OO syntax in a COBOL program to implement a Java 2 Platform, Enterprise Edition (J2EE) client. You can, for example, invoke methods on enterprise beans that run in the WebSphere® for z/OS environment.

Before you run a COBOL J2EE client, you must set the Java system property `java.naming.factory.initial` to access WebSphere naming services. For example:

```
export COBJVMINITOPTIONS  
="-Djava.naming.factory.initial=com.ibm.websphere.naming.WsnInitialContextFactory"
```

"Example: J2EE client written in COBOL" on page 644

Compiling, linking, and running OO applications in JCL or TSO/E

It is recommended that you compile, link, and run applications that use OO syntax in the z/OS UNIX environment.

However, in limited circumstances it is possible to compile, prepare, and run OO applications by using standard batch JCL or TSO/E commands. To do so, you must follow the guidelines that are in the related tasks. For example, you might follow this approach for applications that consist of a COBOL main program and subprograms that:

- Access objects that are all implemented in Java
- Access enterprise beans that run in a WebSphere server

RELATED TASKS

"Compiling OO applications in JCL or TSO/E"

"Preparing and running OO applications in JCL or TSO/E" on page 296

"Compiling, linking, and running OO applications under z/OS UNIX" on page 291

Compiling OO applications in JCL or TSO/E

If you use batch JCL or TSO/E to compile an OO COBOL program or class definition, the generated object file is written, as usual, to the data set that has ddname SYSLIN or SYSPUNCH. You must use compiler options RENT, DLL, THREAD, and DBCS. (RENT and DBCS are defaults.)

If the COBOL program or class definition uses the JNI environment structure to access JNI callable services, copy the file `JNI.cpy` from the z/OS UNIX file system to a PDS or PDSE member called `JNI`, identify that library with a `SYSLIB DD` statement, and use a `COPY` statement of the form `COPY JNI` in the COBOL source.

A COBOL source file that contains a class definition must not contain any other class or program definitions.

When you compile a COBOL class definition, a Java source program that contains a class definition that corresponds to the COBOL class definition is generated in addition to the object file. Use the SYSJAVA ddname to write the generated Java source file to a file in the z/OS UNIX file system. For example:

```
//SYSJAVA DD PATH='/u/userid/java/Classname.java',  
// PATHOPTS=(OWRONLY,OCREAT,OTRUNC),  
// PATHMODE=SIRWXU,  
// FILEDATA=TEXT
```

Do not edit this generated Java class definition in any way. If you change the COBOL class definition, you must regenerate both the object file and the Java class definition by recompiling the updated COBOL class definition.

Compile Java class definitions by using the javac command from a z/OS UNIX shell command prompt, or by using the BPXBATCH utility.

“Example: compiling, linking, and running an OO application using JCL” on page 298

RELATED TASKS

“Compiling with JCL” on page 255

“Compiling under TSO” on page 262

“Specifying source libraries (SYSLIB)” on page 270

“Defining the Java-source output file (SYSJAVA)” on page 272

“Accessing JNI services” on page 633

“Compiling OO applications under z/OS UNIX” on page 291

“Preparing OO applications under z/OS UNIX” on page 292

RELATED REFERENCES

“DBCS” on page 319

“DLL” on page 321

“RENT” on page 352

“THREAD” on page 366

Appendix E, “JNI.cpy copybook,” on page 731

UNIX System Services User's Guide (The BPXBATCH utility)

Preparing and running OO applications in JCL or TSO/E

It is recommended that you run OO applications in a z/OS UNIX environment. To run OO applications from batch JCL or TSO/E, you should therefore use the BPXBATCH utility.

In limited circumstances, however, you can run an OO application by using standard batch JCL (EXEC PGM=COBPROG) or the TSO/E CALL command. To do so, follow these requirements when preparing the application:

- Structure the application to start with a COBOL program. (If an application starts with a Java program or with the main factory method of a COBOL class, you must run the application under z/OS UNIX, and the application components must reside in the z/OS UNIX file system.)
- **Link-edit considerations:** Link the program object for the COBOL program into a PDSE. COBOL programs that contain object-oriented syntax must be link-edited with AMODE 31.

- Ensure that the class files and DLLs associated with the COBOL or Java classes that are used by the application reside in the z/OS UNIX file system. You must name the class files and DLLs as described in the related task about preparing OO applications.
- Specify INCLUDE control statements for the DLL side files libjvm.x and igzjava.x when you bind the object deck for the main program. For example:

```
INCLUDE '/usr/lpp/java/J5.0/bin/j9vm/libjvm.x'
INCLUDE '/usr/lpp/cobol/lib/igzjava.x'
```
- Create a file that contains the environment variable settings that are required for Java. For example, a file `/u/userid/javaenv` might contain the three lines shown below to set the PATH, LIBPATH, and CLASSPATH environment variables.

```
PATH=/bin:/usr/lpp/java/IBM/J7.1/bin
LIBPATH=/lib:/usr/lib:/usr/lpp/java/J5.0/bin:/usr/lpp/java/IBM/J7.1/bin/j9vm
CLASSPATH=./u/userid/applications
```

To customize the initialization of the JVM that will be used by the application, you can set the COBJVMINITOPTIONS environment variable in the same file. For example, to access enterprise beans that run in a WebSphere server, you must set the Java system property `java.naming.factory.initial`. For details, see the related task about running OO applications.

When you run an OO application that starts with a COBOL program by using standard batch JCL or the TSO/E CALL command, follow these guidelines:

- Use the `_CEE_ENVFILE` environment variable to indicate the location of the file that contains the environment variable settings required by Java. Set `_CEE_ENVFILE` by using the ENVAR runtime option.
- Specify the `POSIX(ON)` and `XPLINK(ON)` runtime option.
- Use DD statements to specify files in the z/OS UNIX file system for the standard input, output, and error streams for Java:
 - `JAVAIN` DD for the input from statements such as `c=System.in.read();`
 - `JAVAOUT` DD for the output from statements such as `System.out.println(string);`
 - `JVAERR` DD for the output from statements such as `System.err.println(string);`
- Ensure that the `SCEERUN2` and `SCEERUN` load libraries are available in the system library search order, for example, by using a `STEPLIB` DD statement.

“Example: compiling, linking, and running an OO application using JCL” on page 298

RELATED TASKS

“Preparing OO applications under z/OS UNIX” on page 292

“Running OO applications under z/OS UNIX” on page 293

“Structuring OO applications” on page 630

UNIX System Services User's Guide (The BPXBATCH utility)

Language Environment Programming Guide (Running an application under batch)

RELATED REFERENCES

XL C/C++ Programming Guide (`_CEE_ENVFILE`)

Language Environment Programming Reference (`ENVAR`)

Example: compiling, linking, and running an OO application using JCL

This example shows sample JCL that you could use to compile, link, and run a COBOL client that invokes a Java method.

The example shows:

- JCL to compile, link, and run an OO COBOL program, TSTHELLO
- A Java class definition, HelloJ, that contains a method that the COBOL program invokes
- A z/OS UNIX file, ENV, that contains the environment variable settings that Java requires

JCL for program TSTHELLO

```
//TSTHELLO JOB ,
// TIME=(1),MSGLEVEL=(1,1),MSGCLASS=H,CLASS=A,REGION=200M,
// NOTIFY=&SYSUID,USER=&SYSUID
//*
// SET COBPRFX='IGY.V5R1M0'
// SET LIBPRFX='CEE'
//*
//COMPILE EXEC PGM=IGYCRCTL,
//SYSLIN DD DSN=&OBJECT(TSTHELLO),UNIT=VIO,DISP=(NEW,PASS),
//        SPACE=(CYL,(1,1,1))
//SYSPRINT DD SYSOUT=*
//STEPLIB DD DSN=&COBPRFX..SIGYCOMP,DISP=SHR
//        DD DSN=&LIBPRFX..SCEERUN,DISP=SHR
//        DD DSN=&LIBPRFX..SCEERUN2,DISP=SHR
//SYSUT1 DD UNIT=VIO,SPACE=(CYL,(1,1))
//SYSUT2 DD UNIT=VIO,SPACE=(CYL,(1,1))
//SYSUT3 DD UNIT=VIO,SPACE=(CYL,(1,1))
//SYSUT4 DD UNIT=VIO,SPACE=(CYL,(1,1))
//SYSUT5 DD UNIT=VIO,SPACE=(CYL,(1,1))
//SYSUT6 DD UNIT=VIO,SPACE=(CYL,(1,1))
//SYSUT7 DD UNIT=VIO,SPACE=(CYL,(1,1))
//SYSUT8 DD UNIT=SYSALLDA,SPACE=(CYL,(1,1))
//SYSUT9 DD UNIT=SYSALLDA,SPACE=(CYL,(1,1))
//SYSUT10 DD UNIT=SYSALLDA,SPACE=(CYL,(1,1))
//SYSUT11 DD UNIT=SYSALLDA,SPACE=(CYL,(1,1))
//SYSUT12 DD UNIT=SYSALLDA,SPACE=(CYL,(1,1))
//SYSUT13 DD UNIT=SYSALLDA,SPACE=(CYL,(1,1))
//SYSUT14 DD UNIT=SYSALLDA,SPACE=(CYL,(1,1))
//SYSUT15 DD UNIT=SYSALLDA,SPACE=(CYL,(1,1))
//SYSMDECK DD UNIT=SYSALLDA,SPACE=(CYL,(1,1))
//SYSIN DD *
        cbl dll,thread
        Identification division.
        Program-id. "TSTHELLO" recursive.
        Environment division.
        Configuration section.
        Repository.
            Class HelloJ is "HelloJ".
        Data Division.
        Procedure division.
            Display "COBOL program TSTHELLO entered"
            Invoke HelloJ "sayHello"
            Display "Returned from java sayHello to TSTHELLO"
            Goback.
        End program "TSTHELLO".
/*
//LKED EXEC PGM=IEWL,PARM='RENT,LIST,LET,DYNAM(DLL),CASE(MIXED)'
//SYSLIB DD DSN=&LIBPRFX..SCEELKED,DISP=SHR
//        DD DSN=&LIBPRFX..SCEELKEX,DISP=SHR
//SYSPRINT DD SYSOUT=*
```

```

//SYSTEM DD SYSOUT=*
//SYSLMOD DD DSN=&&GOSET(TSTHELLO),DISP=(MOD,PASS),UNIT=VIO,
//          SPACE=(CYL,(1,1,1)),DSNTYPE=LIBRARY
//SYSDEFSD DD DUMMY
//OBJMOD DD DSN=&&OBJECT,DISP=(OLD,DELETE)
//SYSLIN DD *
//          INCLUDE OBJMOD(TSTHELLO)
//          INCLUDE '/usr/lpp/java/J5.0/bin/j9vm/libjvm.x'
//          INCLUDE '/usr/lpp/cobol/lib/igzccjava.x'
/*
//GO EXEC PGM=TSTHELLO,COND=(4,LT,LKED),
//          PARM='/ENVAR("_CEE_ENVFILE=/u/userid/ootest/tsthello/ENV")
//          POSIX(ON) XPLINK(ON)'
//STEPLIB DD DSN=*.LKED.SYSLMOD,DISP=PASS
//          DD DSN=&LIBPRFX..SCEERUN2,DISP=SHR
//          DD DSN=&LIBPRFX..SCEERUN,DISP=SHR
//SYSOUT DD SYSOUT=*
//CEEDUMP DD SYSOUT=*
//SYSUDUMP DD DUMMY
//JAVAOUT DD PATH='/u/userid/ootest/tsthello/javaout',
//          PATHOPTS=(OWRONLY,OCREAT,OTRUNC),
//          PATHMODE=(SIRUSR,SIWUSR,SIRGRP)
//JAVAERR DD PATH='/u/userid/ootest/tsthello/javaerr',
//          PATHOPTS=(OWRONLY,OCREAT,OTRUNC),
//          PATHMODE=(SIRUSR,SIWUSR,SIRGRP)

```

Definition of class HelloJ

```

class HelloJ {
    public static void sayHello() {
        System.out.println("Hello World, from Java!");
    }
}

```

HelloJ.java is compiled with the `javac` command. The resulting `.class` file resides in the `z/OS UNIX` file system directory `u/userid/ootest/tsthello`, which is specified in the **CLASSPATH** environment variable in the environment variable settings file.

Environment variable settings file, ENV

```

PATH=/bin:/usr/lpp/java/IBM/J7.1/bin.
LIBPATH=/lib:/usr/lib:/usr/lpp/java/J5.0/bin:/usr/lpp/java/IBM/J7.1/bin/j9vm
CLASSPATH=./u/userid/ootest/tsthello

```

The environment variable settings file also resides in directory `u/userid/ootest/tsthello`, as specified in the `_CEE_ENVFILE` environment variable in the JCL.

Using Java SDKs for z/OS

The Java SDKs for z/OS are based on the XPLINK linkage convention defined by Language Environment.

If the application starts with a Java program or the main factory method of a COBOL class, the XPLINK environment is automatically started by the `java` command that starts the JVM and runs the application.

If an application starts with a COBOL program that invokes methods on COBOL or Java classes, you must specify the `XPLINK(ON)` runtime option so that the XPLINK environment is initialized. `XPLINK(ON)` is not recommended as a default setting, however; you should use `XPLINK(ON)` only for applications that specifically require it.

When you are running an application under z/OS UNIX, you can set the XPLINK(ON) option by using the _CEE_RUNOPTS environment variable as follows:
_CEE_RUNOPTS="XPLINK(ON)"

Exporting _CEE_RUNOPTS="XPLINK(ON)" so that it is in effect for the entire z/OS UNIX shell session is not recommended, however. Suppose for example that an OO COBOL application starts with a COBOL program called App1Driver. One way to limit the effect of the XPLINK option to the execution of the App1Driver application is to set the _CEE_RUNOPTS variable on the command-line invocation of App1Driver as follows:

```
_CEE_RUNOPTS="XPLINK(ON)" App1Driver
```

RELATED TASKS

"Running OO applications under z/OS UNIX" on page 293

"Setting and accessing environment variables" on page 464

RELATED REFERENCES

"Object-oriented syntax, and Java 6, Java 7, or Java 8"

"Runtime environment variables" on page 465

Language Environment Programming Reference (XPLINK)

XL C/C++ Programming Guide (_CEE_RUNOPTS)

Object-oriented syntax, and Java 6, Java 7, or Java 8

Enterprise COBOL Version 5.2 applications that use object-oriented syntax for Java interoperability are supported with Java 6 or Java 7.

Earlier versions of Enterprise COBOL applications that use object-oriented syntax for Java interoperability were supported with Java SDK 1.4.2 and Java 5. To run these applications with Java 6, Java 7, or Java 8, , do these steps:

1. Recompile and relink the applications using Enterprise COBOL V5.2.
2. Recompile the generated Java class that is associated with each object-oriented COBOL class using the javac command from Java 6, Java 7, or Java 8.

RELATED TASKS

"Preparing OO applications under z/OS UNIX" on page 292

Chapter 17. Compiler options

You can direct and control your compilation by using compiler options or by using compiler-directing statements (compiler directives).

Compiler options affect the aspects of your program that are listed in the table below. The linked-to information for each option provides the syntax for specifying the option and describes the option, its parameters, and its interaction with other parameters.

Table 43. Compiler options

Aspect of your program	Compiler option	Default	Option abbreviations
Source language	"ARITH" on page 309	ARITH(COMPAT)	AR(C E)
	"CICS" on page 312	NOCICS	None
	"CODEPAGE" on page 313	CODEPAGE(1140)	CP(ccsid)
	"CURRENCY" on page 317	NOCURRENCY	CURR NOCURR
	"DBCS" on page 319	DBCS	None
	"NSYMBOL" on page 340	NSYMBOL(NATIONAL)	NS(DBCS NAT)
	"NUMBER" on page 340	NONUMBER	NUM NONUM
	"QUALIFY" on page 351	QUALIFY(COMPAT)	QA(C E)
	"QUOTE/APOST" on page 352	QUOTE	Q APOST
	"SEQUENCE" on page 356	SEQUENCE	SEQ NOSEQ
	"SQL" on page 358	NOSQL	None
	"SQLCCSID" on page 359	SQLCCSID	SQLC NOSQLC
	"SQLIMS" on page 360	NOSQLIMS	None
	"WORD" on page 372	NOWORD	WD NOWD
"XMLPARSE" on page 373	XMLPARSE(XMLSS)	XP(X) XP(C)	
Date processing	"INTDATE" on page 332	INTDATE(ANSI)	None
Maps and listings	"LANGUAGE" on page 333	LANGUAGE(ENGLISH)	LANG(EN UE JA JP)
	"LINECOUNT" on page 334	LINECOUNT(60)	LC
	"LIST" on page 334	NOLIST	None
	"MAP" on page 335	NOMAP	None
	"OFFSET" on page 345	NOOFFSET	OFF NOOFF
	"SOURCE" on page 357	SOURCE	S NOS
	"SPACE" on page 357	SPACE(1)	None
	"TERMINAL" on page 363	NOTERMINAL	TERM NOTERM
	"VBREF" on page 370	NOVBREF	None
"XREF" on page 374	XREF(FULL)	X NOX	

Table 43. Compiler options (continued)

Aspect of your program	Compiler option	Default	Option abbreviations
Object deck generation	"COMPILE" on page 316	NOCOMPILE(S)	C NOC
	"COPYRIGHT" on page 316	NOCOPYRIGHT	CPYR NOCPYR
	"DECK" on page 319	NODECK	D NOD
	"NAME" on page 339	NONAME, or NAME(NOALIAS) if only NAME is specified	None
	"OBJECT" on page 344	OBJECT	OBJ NOOBJ
	"PGMNAME" on page 348	PGMNAME(COMPAT)	PGMN(CO LU LM)
	"SERVICE" on page 356	NOSERVICE	SERV NOSERV
Object code control	"ADV" on page 306	ADV	None
	"AFP" on page 307	AFP(VOLATILE)	None
	"ARCH" on page 307	ARCH(7)	None
	"AWO" on page 310	NOAWO	None
	"BLOCK0" on page 310	NOBLOCK0	None
	"DISPSIGN" on page 320	DISPSIGN(COMPAT)	DS(S C)
	"DLL" on page 321	NODLL	None
	"EXPORTALL" on page 326	NOEXPORTALL	EXP NOEXP
	"FASTSRT" on page 327	NOFASTSRT	FSRT NOFSRT
	"HGPR" on page 331	HGPR(PRESERVE)	None
	"MAXPCF" on page 336	MAXPCF(60000)	None
	"NUMCHECK" on page 341	NONUMCHECK	NONC NC
	"NUMPROC" on page 343	NUMPROC(NOPFD)	None
	"OPTIMIZE" on page 346	OPTIMIZE(0)	OPT(n)
	"OUTDD" on page 348	OUTDD(SYSOUT)	OUT
	"TRUNC" on page 368	TRUNC(STD)	None
	"VLR" on page 371	VLR(STD)	VLR(C S)
	"ZONECHECK" on page 375	NOZONECHECK	NOZC ZC(MSG) ZC(ABD)
"ZONEDATA" on page 377	ZONEDATA(PFD)	ZD(PFD) ZD(MIG)	
"ZWB" on page 379	ZWB	None	
Virtual storage usage	"BUFSIZE" on page 312	4096	BUF
	"DATA" on page 318	DATA(31)	None
	"DYNAM" on page 323	NODYNAM	DYN NODYN
	"RENT" on page 352	RENT	None
	"RMODE" on page 353	AUTO	None
	"STGOPT" on page 362	NOSTGOPT	S0 NOSO

Table 43. Compiler options (continued)

Aspect of your program	Compiler option	Default	Option abbreviations
Debugging and diagnostics	"DIAGTRUNC" on page 320	NODIAGTRUNC	DTR NODTR
	"DUMP" on page 322	NODUMP	DU NODU
	"FLAG" on page 328	FLAG(I,I)	F NOF
	"FLAGSTD" on page 329	NOFLAGSTD	None
	"INITCHCK" on page 331	NOINITCHCK	IC NOIC
	"RULES" on page 354	NORULES	RULES(ENDP, EVENP, LXPRF, SLCKB) RULES(NOENDP, NOEVENP, NOLXPRF, NOSLCKB)
	"SSRANGE" on page 361	NOSSRANGE	SSR(ZLEN NOZLEN, MSG ABD) NOSSR
	"TEST" on page 364	NOTEST	None
Other	"ADATA" on page 305	NOADATA	None
	"EXIT" on page 324	NOEXIT	NOEX EX(INX NOINX, LIBX NOLIBX, PRTX NOPRTX, ADX NOADX, MSGX NOMSGX)
	"MDECK" on page 337	NOMDECK	NOMD MD MD(C NOC)
	"OPTFILE" on page 345	None	None
	"THREAD" on page 366	NOTHREAD	None
	"VSAMOPENFS" on page 372	VSAMOPENFS(COMPAT)	VS(C S)

Installation defaults: The default compiler options that were set up when your compiler was installed are in effect for your program unless you override those options. (In some installations, certain compiler options are fixed so that you cannot override them. If you have problems with the default options, contact your system administrator.) To determine which are the default options, run a test compilation without specifying any compiler options. The output listing lists the default options in effect at your site.

Nonoverridable options: In some installations, certain compiler options are fixed so that you cannot override them. If you have problems with those options, contact your system administrator.

Option specification: Compiler options and suboptions are not case sensitive.

Performance considerations: The AFP, ARCH, ARITH, AWO, BLOCK0, DYNAM, FASTSRT, HGPR, MAXPCF, NUMCHECK, NUMPROC, OPTIMIZE, RENT, SQLCCSID, SSRANGE, STGOPT, TEST, THREAD, TRUNC, ZONECHECK, and ZONEDATA compiler options can affect runtime performance.

RELATED TASKS

Chapter 14, "Compiling under z/OS," on page 255

"Compiling under TSO" on page 262

Chapter 15, "Compiling under z/OS UNIX," on page 283

Chapter 33, "Tuning your program," on page 661

RELATED REFERENCES

"Conflicting compiler options" on page 304

Option settings for 85 COBOL Standard conformance

Compiler options and runtime options are required for conformance with the 85 COBOL Standard.

The following compiler options are required:

- ADV
- DYNAM
- NAME (ALIAS) or NAME (NOALIAS)
- NOBLOCKO
- NOCICS
- NODLL
- NOEXPORTALL
- NOFASTSRT
- NOTHREAD
- NOWORD
- NUMPROC (NOPFD)
- PGMNAME (COMPAT) or PGMNAME (LONGUPPER)
- QUALIFY (COMPAT)
- QUOTE
- TRUNC (STD)
- VLR (STANDARD)
- VSAMOPENFS (SUCC)
- ZONEDATA (PFD)
- ZWB

You can use the FLAGSTD compiler option to flag nonconforming elements such as IBM extensions.

The following runtime options are required:

- AIXBLD
- CBLQDA (ON)
- TRAP (ON)

RELATED REFERENCES

Language Environment Programming Reference

Conflicting compiler options

The Enterprise COBOL compiler can encounter conflicting compiler options in either of two ways: both the positive and negative form of an option are specified at the same level in the hierarchy of precedence, or mutually exclusive options are specified at the same level in the hierarchy.

When conflicting options are specified at the same level in the hierarchy (such as specifying both DECK and NODECK in a PROCESS or CBL statement), the option specified last takes effect.

If you specify mutually exclusive compiler options at the same level, the compiler generates an error message and forces one of the options to a nonconflicting value. For example, if you specify both OFFSET and LIST in a PROCESS statement in any order, OFFSET takes effect and LIST is ignored.

However, options coded at a higher level of precedence override any options specified at a lower level of precedence. For example, if you code OFFSET in a JCL statement but LIST in a PROCESS statement, LIST takes effect because the options coded in the PROCESS statement and any options forced on by an option coded in the PROCESS statement have higher precedence.

Table 44. Mutually exclusive compiler options

Specified	Ignored ¹	Forced on ¹
CICS	DYNAM	NODYNAM
	NORENT	RENT
DLL	DYNAM	NODYNAM
	NORENT	RENT
EXPORTALL	NODLL	DLL
	DYNAM	NODYNAM
	NORENT	RENT
NORENT	RMODE (ANY)	RMODE (24)
NSYMBOL (NATIONAL)	NOBCS	DBCS
OBJECT	DECK	NODECK
OFFSET	LIST	NOLIST
OPTIMIZE(0)	INITCHECK	NOINITCHECK
PGMNAME(LM LU)	NAME	NONAME
TEST	NOOBJECT and NODECK	OBJECT and NODECK
THREAD	NORENT	RENT
WORD	FLAGSTD	NOFLAGSTD
1. Unless in conflict with a fixed installation default option.		

RELATED TASKS

- “Specifying compiler options under z/OS” on page 272
- “Specifying compiler options in a batch compilation” on page 277
- “Specifying compiler options under z/OS UNIX” on page 284

RELATED REFERENCES

- “OPTFILE” on page 345

ADATA

Use ADATA when you want the compiler to create a SYSADATA file that contains records of additional compilation information.



Default is: NOADATA

Abbreviations are: None

ADATA is required for remote compilation using an IBM Windows COBOL compiler. On z/OS, the SYSADATA file is written to ddname SYSADATA.

The size of the SYSADATA file generally grows with the size of the associated program.

Option specification: You cannot specify the ADATA option in a PROCESS (or CBL) statement. You can specify it only in one of the following ways:

- In the PARM parameter of JCL
- As a cob2 command option
- As an installation default
- In the COBOPT environment variable

RELATED REFERENCES

“Setting environment variables under z/OS UNIX” on page 283

“cob2 syntax and options” on page 287

Appendix F, “COBOL SYSADATA file contents,” on page 737

ADV

ADV has meaning only if you use WRITE . . . ADVANCING in your source code. With ADV in effect, the compiler adds 1 byte to the record length to account for the printer control character.

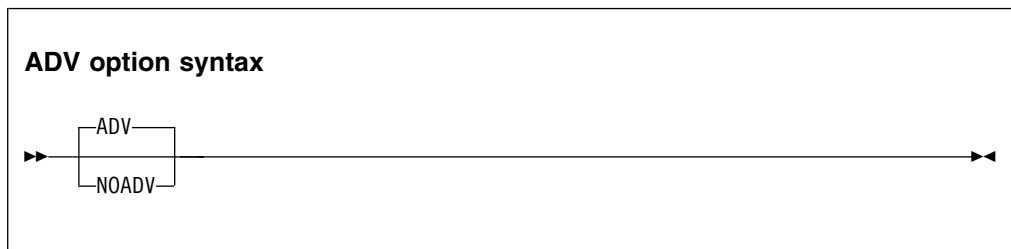

Default is: ADV

Abbreviations are: None

Use NOADV if you already adjusted record length to include 1 byte for the printer control character.

AFP

The AFP option controls the compiler usage of the Additional Floating Point (AFP) registers that are provided by z/Architecture[®] processors.

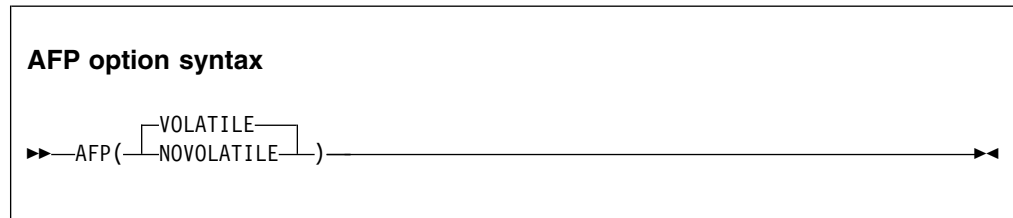

Default is: AFP(VOLATILE)

Abbreviations are: None

The Enterprise COBOL compiler generates code that uses the full complement of 16 floating point registers (FPR) provided by a z/Architecture processor. These FPRs are as follows:

- Original FPRs, which are numbered 0, 2, 4, and 6
- AFP registers, which are numbered 1, 3, 5, 7, and 8-15

Note: If your code runs on a version of CICS Transaction Server that is earlier than V4.1, you must specify AFP(VOLATILE).

AFP(VOLATILE)

If you specify AFP(VOLATILE), the AFP registers 8-15 are considered volatile, which means that they might be changed by a called subprogram. Therefore, the COBOL compiler generates extra code to protect the values in these registers.

AFP(NOVOLATILE)

If you specify AFP(NOVOLATILE), the AFP registers 8-15 are considered nonvolatile, which means that they are known to be unchanged or preserved by every called subprogram. Therefore, the compiler can generate more efficient code sequences for programs with floating point operations. It is the normal z/OS architecture convention.

ARCH

The ARCH option specifies the machine architecture for which the executable program instructions are to be generated.

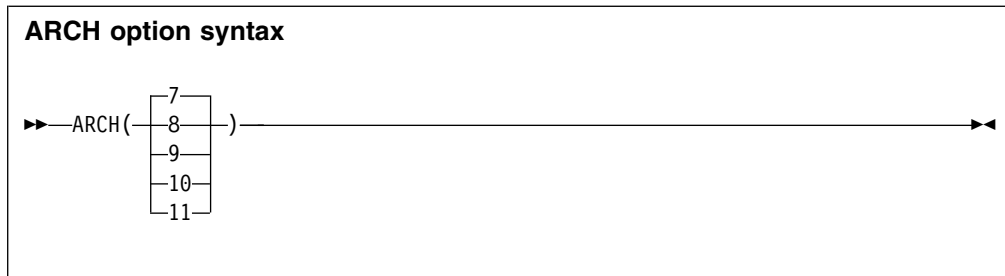

Default is: ARCH(7)

Abbreviations are: None

If you specify a higher ARCH level, the compiler generates code that uses newer and faster instructions. Your application might abend if it runs on a processor with an architecture level lower than what you specified with the ARCH option. Use the ARCH level that matches the lowest machine architecture where your application runs.

Current supported architecture levels and groups of models are as follows:

7 Produces code that uses instructions available on the 2096-xxx (IBM System z9[®] BC) and 2094-xxx (IBM System z9 EC) models in z/Architecture mode.

Specifically, these ARCH(7) machines and their follow-ons add instructions supported by the following facilities:

- Extended-immediate facility
- Decimal floating point facility. These instructions might be generated if decimal data is used in numeric operations.

8 Produces code that uses instructions available on the 2097-xxx (IBM System z10[®] EC) models in z/Architecture mode.

Specifically, these ARCH(8) machines and their follow-ons add instructions supported by the general instruction extensions facility.

9 Produces code that uses instructions available on 2817-xxx (IBM zEnterprise[®] 196) and 2818-xxx (IBM zEnterprise 114) models in z/Architecture mode.

Specifically, these ARCH(9) machines and their follow-ons add instructions supported by the following facilities:

- High-word facility
- Interlocked access facility
- Load/store-on-condition facility
- Distinct-operands facility
- Population-count facility

10 Produces code that uses instructions available on the 2827-xxxx (IBM zEnterprise EC12) models in z/Architecture mode.

Specifically, these ARCH(10) machines and their follow-ons add instructions supported by the following facilities:

- Execution-hint facility
- Load-and-trap facility
- Miscellaneous-instructions-extension facility
- Transactional-execution facility

- Enhanced decimal floating point facility that enables more efficient conversions between zoned decimal data items and decimal floating point data items. Instead of converting zoned decimal data items to packed decimal data items to perform arithmetic, the compiler converts zoned decimal data items directly to decimal floating point data items, and then back again to zoned decimal data items after the computations are complete.

11 Produces code that uses instructions available on the 2964-xxxx (IBM z13[®]) models in z/Architecture mode.

Specifically, these ARCH(11) machines and their follow-ons add instructions with support of the following facilities:

- Enhanced decimal floating point facility that enables more efficient conversions between packed-decimal data items and decimal floating point intermediate result data items
- Exploitation of the new vector extension facility (SIMD) instructions for some INSPECT REPLACING and INSPECT TALLYING statements

Note: A higher ARCH level includes the facilities of the lower ARCH level. For example, ARCH(11) includes all the facilities of the lower ARCH levels.

For more information about these facilities, see *z/Architecture Principles of Operation*.

ARITH

ARITH affects the maximum number of digits that you can code for integers, and the number of digits used in fixed-point intermediate results.

ARITH option syntax

►► ARITH(COMPAT EXTEND) ◀◀

Default is: ARITH(COMPAT)

Abbreviations are: AR(C|E)

When you specify ARITH(EXTEND):

- The maximum number of digit positions that you can specify in the PICTURE clause for packed-decimal, external-decimal, and numeric-edited data items is raised from 18 to 31.
- The maximum number of digits that you can specify in a fixed-point numeric literal is raised from 18 to 31. You can use numeric literals with large precision anywhere that numeric literals are currently allowed, including:
 - Operands of PROCEDURE DIVISION statements
 - VALUE clauses (for numeric data items with large-precision PICTURE)
 - Condition-name values (on numeric data items with large-precision PICTURE)
- The maximum number of digits that you can specify in the arguments to NUMVAL and NUMVAL-C is raised from 18 to 31.

- The maximum value of the integer argument to the FACTORIAL function is 29.
- Intermediate results in arithmetic statements use *extended mode*.

When you specify ARITH(COMPAT):

- The maximum number of digit positions in the PICTURE clause for packed-decimal, external-decimal, and numeric-edited data items is 18.
- The maximum number of digits in a fixed-point numeric literal is 18.
- The maximum number of digits in the arguments to NUMVAL and NUMVAL-C is 18.
- The maximum value of the integer argument to the FACTORIAL function is 28.
- Intermediate results in arithmetic statements use *compatibility mode*.

RELATED CONCEPTS

Appendix A, “Intermediate results and arithmetic precision,” on page 685

AWO

If you specify AWO, an implicit APPLY WRITE-ONLY clause is activated for all QSAM files in the program that have blocked variable-length records.



Default is: NOAWO

Abbreviations are: None

RELATED TASKS

“Optimizing buffer and device space” on page 10

RELATED REFERENCES

“BLOCK0”

APPLY WRITE-ONLY clause (*Enterprise COBOL Language Reference*)

BLOCK0

Use BLOCK0 to change the compiler default for QSAM files from unblocked to blocked (as if BLOCK CONTAINS 0 were specified) and thus gain the benefit of system-determined blocking for output files.

BLOCK0 option syntax

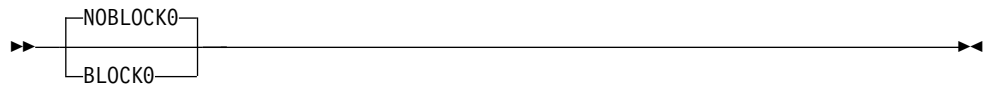

Default is: NOBLOCK0

Abbreviations are: None

Specifying BLOCK0 activates an implicit BLOCK CONTAINS 0 clause for each file in the program that meets the following three criteria:

- The FILE-CONTROL paragraph either specifies ORGANIZATION SEQUENTIAL or omits the ORGANIZATION clause.
- The FD entry does not specify RECORDING MODE U.
- The FD entry does not specify a BLOCK CONTAINS clause.

Files for which the resulting BLOCK CONTAINS 0 clause is in effect have a blocking factor that is determined at run time from the data definition or from the data-set characteristics.

Interaction of the APPLY WRITE-ONLY clause and the AWO compiler option with BLOCK0:

- If NOBLOCK0 is in effect, and the file description of a file that meets the three criteria listed above specifies APPLY WRITE-ONLY, the compiler issues an error message because APPLY WRITE-ONLY applies only to blocked files. But if BLOCK0 is in effect, the result is that the file is blocked, and the APPLY WRITE-ONLY clause is therefore accepted.
- AWO applies to any QSAM files that have blocked variable-length records. If BLOCK0 is in effect, the result is that more files might be blocked than if NOBLOCK0 were in effect; thus AWO might apply to more files than it otherwise would.

Specifying BLOCK0 for existing programs might result in a change of behavior, and in some cases produce undesirable results for files opened as INPUT. For example:

- The OPEN INPUT statement fails for files for which no block size can be determined.
- Programs that continue after handling nonzero FILE STATUS codes for files opened as INPUT might abnormally terminate when executing subsequent I/O statements on those files.

For these reasons, after compiling with BLOCK0 you should investigate and test the effects on your program.

For recommendations about blocking, see the related reference from the *Enterprise COBOL Migration Guide* (in the information about migrating from CMPR2 to NOCMPR2).

RELATED TASKS

“Optimizing buffer and device space” on page 10

“Setting block sizes” on page 167

RELATED REFERENCES

"AWO" on page 310

APPLY WRITE-ONLY clause (*Enterprise COBOL Language Reference*)

BLOCK CONTAINS clause (*Enterprise COBOL Language Reference*)

Enterprise COBOL Migration Guide

(Recommendation for DCB= parameters of JCL)

BUFSIZE

Use BUFSIZE to allocate an amount of main storage to the buffer for each compiler work data set. Usually, a large buffer size improves the performance of the compiler.

BUFSIZE option syntax



The diagram shows the syntax for the BUFSIZE option. It starts with a right-pointing arrow followed by the text "BUFSIZE". This is followed by an opening parenthesis. Inside the parenthesis, there are two alternatives: "nnnnn" and "nnnK". A bracket above "nnnnn" and a bracket below "nnnK" indicate that either can be used. The parenthesis is closed, followed by a long horizontal line with a double-headed arrow at its right end, indicating that the option can be followed by other options.

Default is: 4096

Abbreviations are: BUF

nnnnn specifies a decimal number that must be at least 256.

nnnK specifies a decimal number in 1 KB increments, where 1 KB = 1024 bytes.

BUFSIZE cannot exceed the track capacity for the device used, nor can it exceed the maximum allowed by data management services.

CICS

The CICS compiler option enables the integrated CICS translator and lets you specify CICS suboptions. You must use the CICS option if your COBOL source program contains EXEC CICS or EXEC DLI statements and the program has not been processed by the separate CICS translator.

CICS option syntax

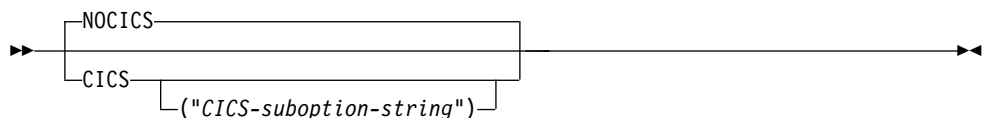

The diagram shows the syntax for the CICS option. It starts with a right-pointing arrow followed by the text "CICS". This is followed by an opening parenthesis. Inside the parenthesis, there are two alternatives: "NOCICS" and "CICS". A bracket above "NOCICS" and a bracket below "CICS" indicate that either can be used. Below "CICS", there is a suboption string: ("CICS-suboption-string"). The parenthesis is closed, followed by a long horizontal line with a double-headed arrow at its right end, indicating that the option can be followed by other options.

Default is: NOCICS

Abbreviations are: None

Use the CICS option only to compile CICS programs. Programs compiled with the CICS option will not run in a non-CICS environment.

If you specify the NOCICS option, any CICS statements found in the source program are diagnosed and discarded.

Use either quotation marks or single quotation marks to delimit the string of CICS suboptions.

You can partition a long CICS suboption string into multiple suboption strings in multiple CBL or PROCESS statements. The CICS suboptions are concatenated in the order of their appearance. For example:

```
//STEP1 EXEC IGYWC, . . .
// PARM.COBOL='CICS("string1")'
//COBOL.SYSIN DD *
    CBL CICS('string2')
    CBL CICS("string3")
    IDENTIFICATION DIVISION.
    PROGRAM-ID. DRIVER1.
    . . .
```

The compiler passes the following suboption string to the integrated CICS translator:

```
"string1 string2 string3"
```

The concatenated strings are delimited with single spaces as shown. If multiple instances of the same CICS suboption are found, the last specification of that suboption in the concatenated string prevails. The compiler limits the size of the concatenated suboption string to 4 KB.

RELATED CONCEPTS

“Integrated CICS translator” on page 435

RELATED TASKS

“Compiling with the CICS option” on page 433

“Separating CICS suboptions” on page 435

CICS Application Programming Guide (Specifying CICS translator options)

RELATED REFERENCES

“Conflicting compiler options” on page 304

CODEPAGE

Use CODEPAGE to specify the coded character set identifier (CCSID) for an EBCDIC code page for processing compile-time and runtime COBOL operations that are sensitive to character encoding.

CODEPAGE option syntax

```
▶▶—CODEPAGE(ccsid)—▶▶
```

Default is: CODEPAGE(1140)

Abbreviations are: CP(*ccsid*)

ccsid must be an integer that represents a valid CCSID for an EBCDIC code page.

The default CCSID 1140 is the equivalent of CCSID 37 (COM EUROPE EBCDIC), but additionally includes the euro symbol.

ccsid specifies these encodings:

- The encoding for alphanumeric, national, and DBCS literals in a COBOL source program
- The default encoding of the content of alphanumeric and DBCS data items at run time
- The encoding for DBCS user-defined words when processed by an XML GENERATE statement to create XML element and attribute names
- The default encoding of an XML document created by an XML GENERATE statement if the receiving data item for the document is alphanumeric
- The default encoding assumed for an XML document in an alphanumeric data item when the document is processed by an XML PARSE statement

The CODEPAGE *ccsid* is used when code-page-sensitive operations are performed at compile time or run time, and an explicit CCSID that overrides the default code page is not specified. Such operations include:

- Conversion of literal values to Unicode
- Conversion of alphanumeric data to and from national (Unicode) data as part of move operations, comparison, or the intrinsic functions DISPLAY-OF and NATIONAL-OF
- Object-oriented language such as INVOKE statements or class definitions and method definitions
- XML parsing
- XML generation
- Processing of DBCS names as part of XML generation at run time
- Processing of SQL string host variables if the SQLCCSID option is in effect
- Processing of source code for EXEC SQL statements
- Processing of source code for EXEC SQLIMS statements

However, the encoding of the following items in a COBOL source program is not affected by the CODEPAGE compiler option:

- Data items that have USAGE NATIONAL
These items are always encoded in UTF-16 in big-endian format, CCSID 1200.
- Characters from the basic COBOL character set (see the table of these characters in the related reference below about characters)

Though the encoding of the basic COBOL characters default currency sign (\$), quotation mark ("), and the lowercase Latin letters varies in different EBCDIC code pages, the compiler always interprets these characters using the EBCDIC code page 1140 encoding. In particular, the default currency sign is always the character with value X'5B' (unless changed by the CURRENCY compiler option or the CURRENCY SIGN clause in the SPECIAL-NAMES paragraph), and the quotation mark is always the character with value X'7F'.

Some COBOL operations can override the CODEPAGE *ccsid* by using an explicit encoding specification, for example:

- DISPLAY-OF and NATIONAL-OF intrinsic functions that specify a code page as the second argument
- XML PARSE statements that specify the WITH ENCODING phrase
- XML GENERATE statements that specify the WITH ENCODING phrase

Additionally, you can use the CURRENCY compiler option or the CURRENCY SIGN clause in the SPECIAL-NAMES paragraph to override:

- The default currency symbol used in the PICTURE character-strings for numeric-edited data items in your source program
- The currency sign value used in the content of numeric-edited data items at run time

DBCS code pages:

Compile your COBOL program using the CODEPAGE option with the *ccsid* set to one of the EBCDIC multibyte character set (MBCS) CCSIDs shown in the table below if the program contains any of the following items:

- User-defined words formed with DBCS characters
- DBCS (USAGE DISPLAY-1) data items
- DBCS literals

All of the CCSIDs in the table below identify mixed code pages that refer to a combination of SBCS and DBCS coded character sets. These are also the CCSIDs that are supported for mixed data by DB2.

Table 45. EBCDIC multibyte coded character set identifiers

National language	MBCS CCSID	SBCS CCSID component	DBCS CCSID component
Japanese (Katakana-Kanji)	930	290	300
Japanese (Katakana-Kanji with euro)	1390	8482	16684
Japanese (Katakana-Kanji)	5026	290	4396
Japanese (Latin-Kanji)	939	1027	300
Japanese (Latin-Kanji with euro)	1399	5123	16684
Japanese (Latin-Kanji)	5035	1027	4396
Korean	933	833	834
Korean	1364	13121	4930
Simplified Chinese	935	836	837
Simplified Chinese	1388	13124	4933
Traditional Chinese	937	28709	835

Note: If you specify the TEST option, you must set the CODEPAGE option to the CCSID that is used for the COBOL source program. In particular, programs that use Japanese characters in DBCS literals or DBCS user-defined words must be compiled with the CODEPAGE option set to a Japanese codepage CCSID.

RELATED CONCEPTS

“COBOL and DB2 CCSID determination” on page 447

RELATED TASKS

“Using currency signs” on page 65

Chapter 28, "Processing XML input," on page 527
Chapter 29, "Producing XML output," on page 571

RELATED REFERENCES

"CURRENCY" on page 317
"SQLCCSID" on page 359
"TEST" on page 364
"The encoding of XML documents" on page 546
Characters (*Enterprise COBOL Language Reference*)

COMPILE

Use the COMPILE option only if you want to force full compilation even in the presence of serious errors. All diagnostics and object code will be generated. Do not try to run the object code if the compilation resulted in serious errors: the results could be unpredictable or an abnormal termination could occur.



Default is: NOCOMPILE(S)

Abbreviations are: C | NOC

Use NOCOMPILE without any suboption to request a syntax check (only diagnostics produced, no object code). If you use NOCOMPILE without any suboption, several compiler options will have no effect because no object code will be produced, for example: DECK, LIST, OBJECT, OFFSET, OPTIMIZE, SSRANGE, and TEST.

Use NOCOMPILE with suboption W, E, or S for conditional full compilation. Full compilation (diagnosis and object code) will stop when the compiler finds an error of the level you specify (or higher), and only syntax checking will continue.

RELATED TASKS

"Finding coding errors" on page 390

RELATED REFERENCES

"Messages and listings for compiler-detected errors" on page 280

COPYRIGHT

Use COPYRIGHT to place a string in the object module if the object module is generated. If the object is linked into a program object, the string is loaded into memory with that program object.

COPYRIGHT option syntax

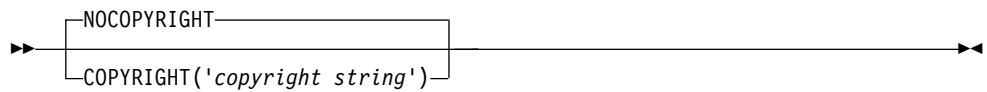

Default is: NOCOPYRIGHT

Abbreviations are: CPYR | NOCPYR

The *copyright string* is limited to 64 characters in length.

CURRENCY

You can use the CURRENCY option to provide an alternate default currency symbol to be used for a COBOL program. (The default currency symbol is the dollar sign (\$).)

CURRENCY option syntax



Default is: NOCURRENCY

Abbreviations are: CURR | NOCURR

NOCURRENCY specifies that no alternate default currency symbol will be used.

To change the default currency symbol, specify `CURRENCY(literal)`, where *literal* is a valid COBOL alphanumeric literal (optionally a hexadecimal literal) that represents a single character. The literal must not be from the following list:

- Digits zero (0) through nine (9)
- Uppercase alphabetic characters A B C D E G N P R S V X Z or their lowercase equivalents
- The space
- Special characters * + - / , . ; () " =
- A figurative constant
- A null-terminated literal
- A DBCS literal
- A national literal

If your program processes only one currency type, you can use the CURRENCY option as an alternative to the CURRENCY SIGN clause for indicating the currency symbol you will use in the PICTURE clause of your program. If your program

processes more than one currency type, you should use the CURRENCY SIGN clause with the WITH PICTURE SYMBOL phrase to specify the different currency sign types.

If you use both the CURRENCY option and the CURRENCY SIGN clause in a program, the CURRENCY option is ignored. Currency symbols specified in the CURRENCY SIGN clause or clauses can be used in PICTURE clauses.

When the NOCURRENCY option is in effect and you omit the CURRENCY SIGN clause, the dollar sign (\$) is used as the PICTURE symbol for the currency sign.

Delimiter: You can delimit the CURRENCY option literal with either quotation marks or single quotation marks, regardless of the QUOTE|APOST compiler option setting.

RELATED TASKS

“Using currency signs” on page 65

DATA

The DATA option affects whether storage for dynamic data areas and other dynamic runtime storage is obtained from above or below the 16 MB line.



Default is: DATA(31)

Abbreviations are: None

For reentrant programs, the DATA compiler option and the HEAP runtime option control whether storage for dynamic data areas (such as WORKING-STORAGE and FD record areas) is obtained from below the 16 MB line (DATA(24)) or from unrestricted storage (DATA(31)). (DATA does not affect the location of LOCAL-STORAGE data; the STACK runtime option controls that location instead, along with the AMODE of the program.)

Specify DATA(24) for programs that run in 31-bit addressing mode and that pass data arguments to programs in 24-bit addressing mode. Doing so ensures that the data will be addressable by the called program.

External data and QSAM buffers: The DATA option interacts with other compiler options and runtime options that affect storage and its addressability. See the related information for details.

RELATED CONCEPTS

“Storage and its addressability” on page 39

RELATED TASKS

Language Environment Programming Guide (Using runtime options)

RELATED REFERENCES

"Allocation of buffers for QSAM files" on page 181

DBCS

Using DBCS causes the compiler to recognize X'0E' (SO) and X'0F' (SI) as shift codes for the double-byte portion of an alphanumeric literal.



Default is: DBCS

Abbreviations are: None

With DBCS in effect, the double-byte portion of the literal is syntax-checked and the literal remains category alphanumeric.

RELATED REFERENCES

"Conflicting compiler options" on page 304

DECK

Use DECK to produce object code in the form of 80-column records. If you use the DECK option, be certain that SYSPUNCH is defined in your JCL for compilation.



Default is: NODECK

Abbreviations are: D|NOD

RELATED TASKS

"Creating object code (SYSLIN or SYSPUNCH)" on page 271

DIAGTRUNC

DIAGTRUNC causes the compiler to issue a severity-4 (Warning) diagnostic message for MOVE statements that have numeric receivers when the receiving data item has fewer integer positions than the sending data item or literal. In statements that have multiple receivers, the message is issued separately for each receiver that could be truncated.



Default is: NODIAGTRUNC

Abbreviations are: DTR|NODTR

The diagnostic message is also issued for implicit moves associated with statements such as these:

- INITIALIZE
- READ . . . INTO
- RELEASE . . . FROM
- RETURN . . . INTO
- REWRITE . . . FROM
- WRITE . . . FROM

The diagnostic message is also issued for moves to numeric receivers from alphanumeric data-names or literal senders, except when the sending field is reference modified.

There is no diagnostic message for COMP-5 receivers, nor for binary receivers when you specify the TRUNC(BIN) option.

RELATED CONCEPTS

“Formats for numeric data” on page 47

“Reference modifiers” on page 113

RELATED REFERENCES

“TRUNC” on page 368

DISPSIGN

The DISPSIGN option controls output formatting for DISPLAY of signed numeric items.

DISPSIGN option syntax

►► DISPSIGN(COMPAT
SEP) ►►

Default is: DISPSIGN(COMPAT)

Abbreviations are: DS(C | S)

DISPSIGN(COMPAT)

If you specify DISPSIGN(COMPAT), formatting for displayed values of signed numeric items is compatible with prior versions of Enterprise COBOL. Overpunch signs are generated in some cases.

DISPSIGN(SEP)

If you specify DISPSIGN(SEP), the displayed values for signed binary, signed packed-decimal, or overpunch signed zoned-decimal items are always formatted with a leading separate sign.

The following example shows the DISPLAY output with the DISPSIGN(COMPAT) option or the DISPSIGN(SEP) option specified:

Table 46. DISPLAY output with the DISPSIGN(COMPAT) option or the DISPSIGN(SEP) option specified:

Data items	DISPLAY output with the DISPSIGN(COMPAT) option specified	DISPLAY output with the DISPSIGN(SEP) option specified
Unsigned binary	111	111
Positive binary	111	+111
Negative binary	11J	-111
Unsigned packed-decimal	222	222
Positive packed-decimal	222	+222
Negative packed-decimal	22K	-222
Zoned-decimal unsigned	333	333
Zoned-decimal trailing positive	33C	+333
Zoned-decimal trailing negative	33L	-333
Zoned-decimal leading positive	C33	+333
Zoned-decimal leading negative	L33	-333

DLL

Use DLL to instruct the compiler to generate an object module that is enabled for dynamic link library (DLL) support. DLL enablement is required if the program will be part of a DLL, will reference DLLs, or if the program contains object-oriented COBOL syntax such as INVOKE statements or class definitions.

Note: The DLL option can be overridden for particular CALL statements by using the CALLINTERFACE directive.

DLL option syntax



Default is: NODLL

Abbreviations are: None

Link-edit considerations: COBOL programs that are compiled with the DLL option must be link-edited with the RENT and AMODE 31 link-edit options.

NODLL instructs the compiler to generate an object module that is not enabled for DLL usage.

RELATED TASKS

“Making dynamic calls” on page 477

RELATED REFERENCES

“Conflicting compiler options” on page 304

CALLINTERFACE (*Enterprise COBOL Language Reference*)

DUMP

Use DUMP to produce a system dump at compile time for an internal compiler error.

DUMP option syntax



Default is: NODUMP

Abbreviations are: DU | NODU

Not for general use: The DUMP option should be used only at the request of an IBM representative.

The dump, which consists of a listing of the compiler's registers and a storage dump, is intended primarily for diagnostic personnel for determining errors in the compiler.

If you use the DUMP option, include a DD statement at compile time to define SYSABEND, SYSUDUMP, or SYSMDUMP.

With DUMP, the compiler will not issue a diagnostic message before abnormal termination processing. Instead, a user abend will be issued with an IGYppnnnn message. In general, a message IGYppnnnn corresponds to a compile-time user abend nnnn. However, both IGYpp5nnn and IGYpp1nnn messages produce a user abend of 1nnn. You can usually distinguish whether the message is really a 5nnn or a 1nnn by recompiling with the NODUMP option.

Use NODUMP if you want normal termination processing, including:

- Diagnostic messages produced so far in compilation.
- A description of the error.
- The name of the compiler phase currently executing.
- The line number of the COBOL statement being processed when the error was found. (If you compiled with OPTIMIZE(1|2), the line number might not always be correct; for some errors, it will be the last line in the program.)
- The contents of the general purpose registers.

Using the DUMP and OPTIMIZE(1|2) compiler options together could cause the compiler to produce a system dump instead of the following optimizer message:

```
"IGYOP3124-W This statement may cause a program exception at
                execution time."
```

This situation does not represent a compiler error. Using the NODUMP option will allow the compiler to issue message IGYOP3124-W and continue processing.

RELATED TASKS

Language Environment Debugging Guide (Understanding abend codes)

RELATED REFERENCES

"Conflicting compiler options" on page 304

DYNAM

Use DYNAM to cause nonnested, separately compiled programs invoked through the CALL *literal* statement to be loaded for CALL, and deleted for CANCEL, dynamically at run time.

Note: The DYNAM option can be overridden for particular CALL statements by using the CALLINTERFACE directive.

CALL *identifier* statements always result in a runtime load of the target program and are not affected by this option.

DYNAM option syntax



Default is: NODYNAM

Abbreviations are: DYN | NODYN

Restriction: The DYNAM compiler option must not be used in the following cases:

- COBOL programs that are processed by the CICS translator or the CICS compiler option
- COBOL programs that have EXEC SQL statements and are run under CICS or DB2 call attach facility (CAF)

If your COBOL program calls programs that have been linked as dynamic link libraries (DLLs), you must not use the DYNAM option. You must instead compile the program with the NODYNAM and DLL options.

RELATED TASKS

“Making both static and dynamic calls” on page 481

“Choosing the DYNAM or NODYNAM compiler option” on page 451

RELATED REFERENCES

“Conflicting compiler options” on page 304

CALLINTERFACE (*Enterprise COBOL Language Reference*)

EXIT

Use the EXIT option to provide user-supplied modules in place of various compiler functions.

For compiler input, use the INEXIT and LIBEXIT suboptions to provide modules in place of SYSIN and SYSLIB (or copy library), respectively. For compiler output, use the PRTEXT suboption to provide a module in place of SYSPRINT.

To provide a module that will be called for each SYSADATA record immediately after the record has been written out to the file, use the ADEXIT suboption.

To customize compiler messages (change their severity or suppress them, including converting FIPS (FLAGSTD) messages to diagnostic messages to which you assign a severity), use the MSGEXIT suboption. The module that you provide to customize the messages will be called each time the compiler issues a diagnostic message or a FIPS message.

EXIT option syntax

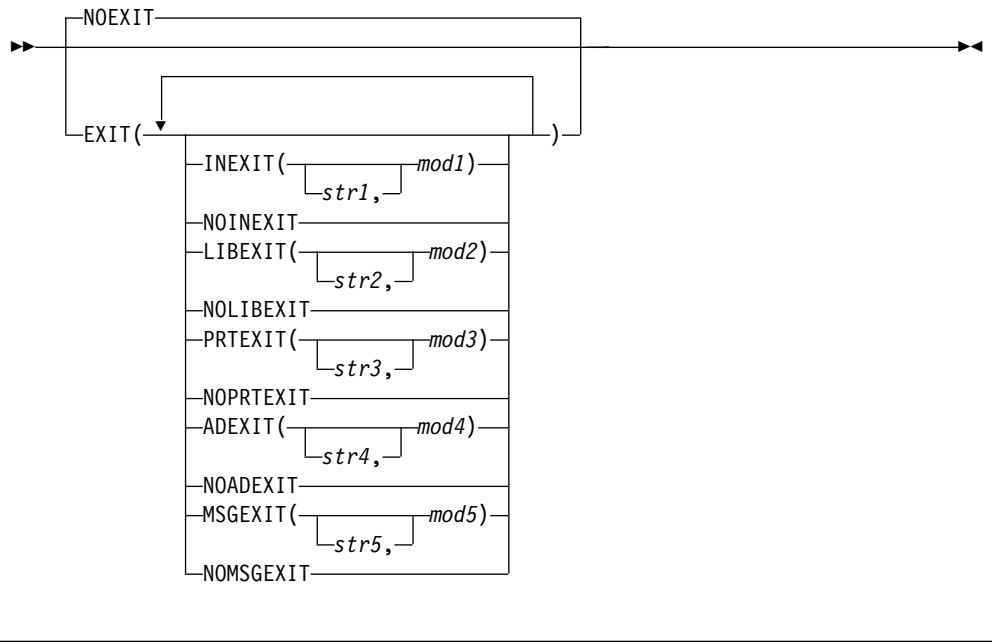

Default is: NOEXIT

Abbreviations are: NOEX|EX(INX|NOINX, LIBX|NOLIBX, PRTX|NOPRTX, ADX|NOADX, MSGX|NOMSGX)

You can specify the suboptions in any order, and can separate them by either commas or spaces. If you specify both the positive and negative form of a suboption, the form specified last takes effect. If you specify the same suboption more than once, the last one specified takes effect.

If you specify the EXIT option without specifying at least one suboption, NOEXIT will be in effect.

You can specify the EXIT option only at invocation in the JCL PARM field (under TSO/E, in a command argument) or at installation time. Do not specify the EXIT option in a PROCESS (CBL) statement.

INEXIT(['str1'],mod1)

The compiler reads source code from a user-supplied program object (where *mod1* is the module name) instead of SYSIN.

LIBEXIT(['str2'],mod2)

The compiler obtains copybooks from a user-supplied program object (where *mod2* is the module name) instead of *library-name* or SYSLIB. For use with either COPY or BASIS statements.

PRTEXTIT(['str3'],mod3)

The compiler passes printer-destined output to the user-supplied program object (where *mod3* is the module name) instead of SYSPRINT.

ADEXIT(['str4'],mod4)

The compiler passes the SYSADATA output to the user-supplied program object (where *mod4* is the module name).

MSGEXIT(['str5'],mod5)

The compiler passes the message number, and passes the default severity of a compiler diagnostic message, or the category (as a numeric code) of a FIPS compiler message, to the user-supplied program object (where *mod5* is the module name).

The names *mod1*, *mod2*, *mod3*, *mod4*, and *mod5* can refer to the same module.

The suboptions *str1*, *str2*, *str3*, *str4*, and *str5* are character strings that are passed to the program object. These strings are optional. They can be up to 64 characters in length, and you must enclose them in single quotation marks. You can use any character in the strings, but any included single quotation marks must be doubled. Lowercase characters are folded to uppercase.

If one of *str1*, *str2*, *str3*, *str4*, or *str5* is specified, that string is passed to the appropriate user-exit module in the following format, where LL is a halfword (on a halfword boundary) that contains the length of the string.

LL *string*

“Example: MSGEXIT user exit” on page 723

Compiler exit modules that are specified on the EXIT option can be implemented either in an assembler language or in a high-level programming language such as COBOL. However, when exits are written in a Language Environment conforming programming language or Language Environment conforming assembler language, the exit must be reentrant.

The Enterprise COBOL compiler automatically manages a preinitialized Language Environment at compile time, and calls compiler exits within this environment. Therefore, the following rules apply:

- Compiler exits are run as subprograms instead of main programs.
- Compiler exits must not include logic for explicitly initializing or terminating Language Environment. In particular, exits must not use the RTEREUS runtime option, the IGZERRE callable service, or the CEEPIPI callable service for environment management.
- Compiler exits must not use the STOP RUN statement.

RELATED REFERENCES

“Conflicting compiler options” on page 304

“FLAGSTD” on page 329

Appendix D, “EXIT compiler option,” on page 711

EXPORTALL

Use EXPORTALL to instruct the compiler to automatically export the PROGRAM-ID name and each alternate entry-point name from each program definition when the object deck is link-edited to form a DLL.

EXPORTALL option syntax

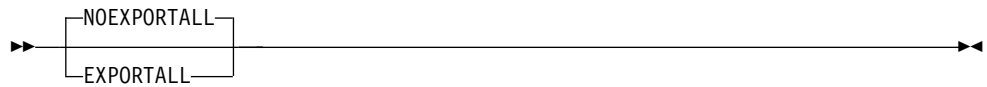

Default is: NOEXPORTALL

Abbreviations are: EXP | NOEXP

With these symbols exported from the DLL, the exported program and entry-point names can be called from programs in the root program object, in other DLL program objects in the application, and from programs that are linked into that DLL.

Specification of the EXPORTALL option requires that the RENT linker option also be used.

NOEXPORTALL instructs the compiler to not export any symbols. In this case the programs are accessible only from other routines that are link-edited into the same program object as the COBOL program definition.

RELATED REFERENCES

“Conflicting compiler options” on page 304

FASTSRT

Use FASTSRT to let IBM DFSORT, or an equivalent product, perform sort input and output instead of Enterprise COBOL. It applies only to sorting files by using the format 1 SORT (that is, file SORT) statement.

FASTSRT option syntax



Default is: NOFASTSRT

Abbreviations are: FSRT | NOFSRT

RELATED TASKS

“Improving sort performance with FASTSRT” on page 231

FLAG

Use FLAG(x) to produce diagnostic messages at the end of the source listing for errors of a severity level x or above.



Default is: FLAG(I,I)

Abbreviations are: F|NOF

x and y can be either I, W, E, S, or U.

Use FLAG(x,y) to produce diagnostic messages for errors of severity level x or above at the end of the source listing, with error messages of severity y and above to be embedded directly in the source listing. The severity coded for y must not be lower than the severity coded for x . To use FLAG(x,y), you must also specify the SOURCE compiler option.

Error messages in the source listing are set off by the embedding of the statement number in an arrow that points to the message code. The message code is followed by the message text. For example:

```
000413      MOVE CORR WS-DATE TO HEADER-DATE
==000413==>  IGYP2121-S      " WS-DATE " was not defined as a data-name. . . .
```

When FLAG(x,y) is in effect, messages of severity y and above are embedded in the listing after the line that caused the message. (See the related reference below for information about messages for exceptions.)

Use NOFLAG to suppress error flagging. NOFLAG does not suppress error messages for compiler options.

Embedded messages

- Embedding level-U messages is not recommended. The specification of embedded level-U messages is accepted, but does not produce any messages in the source.
- The FLAG option does not affect diagnostic messages that are produced before the compiler options are processed.
- Diagnostic messages that are produced during processing of compiler options, CBL or PROCESS statements, or BASIS, COPY, or REPLACE statements are not embedded in the source listing. All such messages appear at the beginning of the compiler output.

- Messages that are produced during processing of the *CONTROL or *CBL statement are not embedded in the source listing.

RELATED REFERENCES

"Messages and listings for compiler-detected errors" on page 280

FLAGSTD

Use FLAGSTD to specify the level or subset of the 85 COBOL Standard to be regarded as conforming, and to get informational messages about the 85 COBOL Standard elements that are included in your program.

You can specify any of the following items for flagging:

- A selected Federal Information Processing Standard (FIPS) COBOL subset
- Any of the optional modules
- Obsolete language elements
- Any combination of subset and optional modules
- Any combination of subset and obsolete elements
- IBM extensions (these are flagged any time that FLAGSTD is specified, and identified as "nonconforming nonstandard")

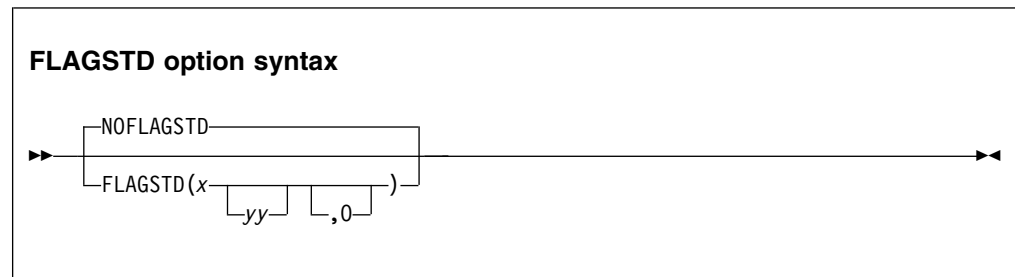

Default is: NOFLAGSTD

Abbreviations are: None

x specifies the subset of the 85 COBOL Standard to be regarded as conforming:

- M** Language elements that are not from the minimum subset are to be flagged as "nonconforming standard."
- I** Language elements that are not from the minimum or the intermediate subset are to be flagged as "nonconforming standard."
- H** The high subset is being used and elements will not be flagged by subset. Elements that are IBM extensions will be flagged as "nonconforming Standard, IBM extension."

yy specifies, by a single character or combination of any two, the optional modules to be included in the subset:

- D** Elements from debug module level 1 are not flagged as "nonconforming standard."
- N** Elements from segmentation module level 1 are not flagged as "nonconforming standard."

S Elements from segmentation module level 2 are not flagged as "nonconforming standard."

If S is specified, N is included (N is a subset of S).

0 (the letter) specifies that obsolete language elements are flagged as "obsolete."

The informational messages appear in the source program listing, and identify:

- The element as "obsolete," "nonconforming standard," or "nonconforming nonstandard" (a language element that is both obsolete and nonconforming is flagged as obsolete only)
- The clause, statement, or header that contains the element
- The source program line and beginning location of the clause, statement, or header that contains the element
- The subset or optional module to which the element belongs

FLAGSTD requires the standard set of reserved words.

In the following example, the line number and column where a flagged clause, statement, or header occurred are shown with the associated message code and text. After that is a summary of the total number of flagged items and their type.

LINE	COL	CODE	FIPS MESSAGE TEXT
		IGYDS8211	Comment lines before "IDENTIFICATION DIVISION": nonconforming nonstandard, IBM extension to ANS/ISO 1985.
11.14		IGYDS8111	"GLOBAL clause": nonconforming standard, ANS/ISO 1985 high subset.
59.12		IGYPS8169	"USE FOR DEBUGGING statement": obsolete element in ANS/ISO 1985.
FIPS MESSAGES TOTAL			STANDARD NONSTANDARD OBSOLETE
			3 1 1 1

You can convert FIPS informational messages into diagnostic messages, and can suppress FIPS messages, by using the MSGEXIT suboption of the EXIT compiler option. For details, see the related reference about the processing of MSGEXIT, and see the related task.

RELATED TASKS

"Customizing compiler-message severities" on page 720

RELATED REFERENCES

"Conflicting compiler options" on page 304

"Processing of MSGEXIT" on page 719

HGPR

The HGPR option controls the compiler usage of the 64-bit registers provided by z/Architecture processors.

HGPR option syntax

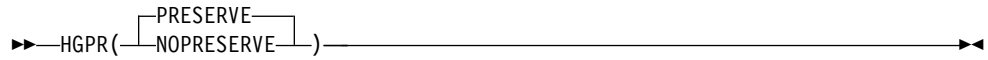
A diagram showing the syntax for the HGPR option. It consists of a horizontal line with arrowheads at both ends. On the left side, the text 'HGPR(' is followed by a bracketed choice between 'PRESERVE' and 'NOPRESERVE'. The closing parenthesis ')' is on the right side of the line.

```
▶▶ HGPR( PRESERVE  
NOPRESERVE ) ▶▶
```

Default is: HGPR(PRESERVE)

Abbreviations are: None

The Enterprise COBOL compiler uses the 64-bit width of the z/Architecture General Purpose Registers (GPRs). HGPR stands for "High-halves of 64-bit GPRs", which means the use of native 64-bit instructions.

HGPR(PRESERVE)

If you specify HGPR(PRESERVE), the compiler preserves the high halves of the 64-bit GPRs that a program is using, by saving them in the prolog for the function and restoring them in the epilog. The PRESERVE suboption is necessary only if the caller of the program is not Enterprise COBOL, Enterprise PL/I, or z/OS XL C/C++ compiler-generated code.

HGPR(NOPRESERVE)

If you specify HGPR(NOPRESERVE), the compiler omits preserving the high-halves of the 64-bit GPRs that a program is using, which improves performance.

INITCHECK

Use the INITCHECK option to have the compiler check for uninitialized data items and issue warning messages when they are used without being initialized.

INITCHECK option syntax

A diagram showing the syntax for the INITCHECK option. It consists of a horizontal line with arrowheads at both ends. On the left side, the text 'INITCHECK(' is followed by a bracketed choice between 'NOINITCHECK' and 'INITCHECK'. The closing parenthesis ')' is on the right side of the line.

```
▶▶ INITCHECK( NOINITCHECK  
INITCHECK ) ▶▶
```

Default is: NOINITCHECK

Abbreviations are: IC|NOIC

NOINITCHECK

If NOINITCHECK is in effect, the compiler will not issue any warning messages for uninitialized data items.

INITCHECK

If INITCHECK is in effect, the compiler will check for uninitialized data items and issue a warning message when a data item is used without being initialized. However, if a data item is possibly initialized when it is used in a statement, no warning message will be issued.

Restrictions:

- The INITCHECK option analyzes data items in the WORKING-STORAGE SECTION and LOCAL-STORAGE SECTION only. In particular, it does not analyze data items in the LINKAGE SECTION or FILE SECTION.
- The INITCHECK option does not track external or global data items.
- The INITCHECK option does not track individual elements in tables independently. Instead, if one element of a table is initialized, all corresponding elements of the table are considered to be initialized. This applies to both fixed-length and variable-length tables.
- The INITCHECK analysis does not track the initialization of items if it happens through a pointer. For example, if a pointer to an uninitialized data item is created by using ADDRESS-OF, and that data item is initialized through that pointer, the INITCHECK analysis might also issue a warning message.
- For uninitialized data items being passed BY REFERENCE, no warning messages will be issued. However, the INITCHECK analysis will warn about uninitialized data items being passed BY CONTENT and BY VALUE.
- The INITCHECK option does not track individual bytes of reference-modified data items accurately. Instead, if a data item is accessed by using a reference modification, this data item is considered to be initialized.
- The INITCHECK option is forced off when OPTIMIZE(0) is used.

Note:

- All of the INITCHECK analyses occur at compile time only.
- The INITCHECK option has no effect on the behavior or performance of the program after it has been compiled.
- Use of the INITCHECK option might increase compile time and memory consumption.

INTDATE

INTDATE(ANSI) instructs the compiler to use the 85 COBOL Standard starting date for integer dates used with date intrinsic functions. Day 1 is Jan 1, 1601.

INTDATE(LILIAN) instructs the compiler to use the Language Environment Lilian starting date for integer dates used with date intrinsic functions. Day 1 is Oct 15, 1582.

INTDATE option syntax

▶▶—INTDATE(——)▶▶

Default is: INTDATE(ANSI)

Abbreviations are: None

With INTDATE(LILIAN), the date intrinsic functions return results that are compatible with the Language Environment date callable services.

Usage note: When INTDATE(LILIAN) is in effect, CEECBLDY is not usable because you have no way to turn an ANSI integer into a meaningful date by using either intrinsic functions or callable services. If you code a CALL *literal* statement with CEECBLDY as the target of the call when INTDATE(LILIAN) is in effect, the compiler diagnoses this and converts the call target to CEEDAYS.

RELATED TASKS

“Using date callable services” on page 60

LANGUAGE

Use the LANGUAGE option to select the language in which compiler output will be printed. The information that will be printed in the selected language includes diagnostic messages, source listing page and scale headers, FIPS message headers, message summary headers, compilation summary, and headers and notations that result from the selection of certain compiler options (MAP, XREF, VBREF, and FLAGSTD).

LANGUAGE option syntax

▶▶—LANGUAGE(*name*)—————▶▶

Default is: LANGUAGE(ENGLISH)

Abbreviations are: LANG(EN | UE | JA | JP)

name specifies the language for compiler output messages. Possible values for the LANGUAGE option are shown in the table below.

Table 47. Values of the LANGUAGE compiler option

Name	Abbreviation ¹	Output language
ENGLISH	EN	Mixed-case English (the default)
JAPANESE	JA, JP	Japanese, using the Japanese character set
UENGLISH ²	UE	Uppercase English

1. If your installation's system programmer has provided a language other than those described, you must specify at least the first two characters of this other language's name.
2. To specify a language other than UENGLISH, the appropriate language feature must be installed.

If the LANGUAGE option is changed at compile time (using CBL or PROCESS statements), some initial text will be printed using the language that was in effect at the time the compiler was started.

NATLANG: The NATLANG runtime option allows you to control the national language to be used for the runtime environment, including error messages, month names, and day-of-the-week names. The LANGUAGE compiler option and the NATLANG runtime option act independently of each other. You can use them together with neither taking precedence over the other.

LINECOUNT

Use LINECOUNT(*nnn*) to specify the number of lines to be printed on each page of the compilation listing, or use LINECOUNT(0) to suppress pagination.

LINECOUNT option syntax

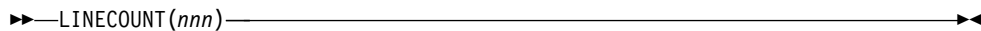

```
▶—LINECOUNT(nnn)—▶
```

Default is: LINECOUNT(60)

Abbreviations are: LC

nnn must be an integer between 10 and 255, or 0.

If you specify LINECOUNT(0), no page ejects are generated in the compilation listing.

The compiler uses three lines of *nnn* for titles. For example, if you specify LINECOUNT(60), 57 lines of source code are printed on each page of the output listing.

LIST

Use the LIST compiler option to produce a listing of the assembler-language expansion of your source code.

LIST option syntax



```
▶—  
┌ NOLIST  
└ LIST  
—▶
```

Default is: NOLIST

Abbreviations are: None

These items will also be written to the output listing:

- Constant area
- Program prolog areas (PPA1, PPA2, PPA3, PPA4)
- Time stamp and compiler version information
- Compiler options and program information
- Base locator table
- External symbols dictionary
- Static maps
- Automatic maps

The output is generated if:

- You specify the `COMPILE` option, or the `NOCOMPILE(x)` option is in effect and an error of level x or higher does not occur.
- You do not specify the `OFFSET` option.

If you want to limit the assembler listing output, use `*CONTROL` (or `*CBL`) `LIST` or `NOLIST` statements in the `PROCEDURE DIVISION`. Source statements that follow a `*CONTROL NOLIST` statement are not included in the listing until a subsequent `*CONTROL LIST` statement switches the output back to normal `LIST` format.

RELATED TASKS

“Getting listings” on page 395

RELATED REFERENCES

“Conflicting compiler options” on page 304

`*CONTROL (*CBL)` statement (*Enterprise COBOL Language Reference*)

MAP

Use the `MAP` option to create a listing of the `DATA DIVISION` items and all implicitly declared items. You can also specify whether hexadecimal or decimal offsets are shown for `MAP` output in the listing.

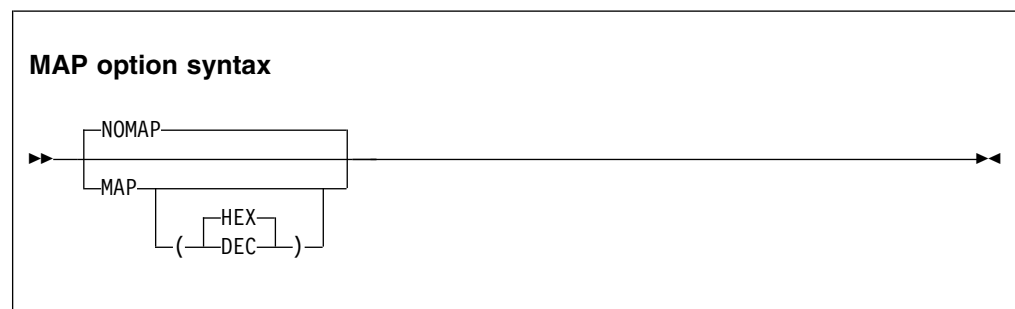

Default is: `NOMAP`

Suboption default is: `MAP(HEX)` if `MAP` is specified with no suboption

Abbreviations are: None

HEX If you specify `MAP(HEX)`, data item offsets within groups will be in hexadecimal notation.

DEC If you specify MAP(DEC), data item offsets within groups will be in decimal notation.

The output includes the following items:

- DATA DIVISION map
- Nested program structure map, and program attributes
- Size of the program's WORKING-STORAGE and LOCAL-STORAGE and its location in the object code if the program is compiled with the NORENT option

If you want to limit the MAP output, use *CONTROL MAP or NOMAP statements in the DATA DIVISION. Source statements that follow *CONTROL NOMAP are not included in the listing until a *CONTROL MAP statement switches the output back to normal MAP format. For example:

```
*CONTROL NOMAP          *CBL NOMAP
   01 A                  01 A
   02 B                  02 B
*CONTROL MAP            *CBL MAP
```

When the MAP(HEX|DEC) option is in effect, you also get an embedded MAP report in the source code listing. The condensed MAP information is shown to the right of data-name definitions in the WORKING-STORAGE SECTION, FILE SECTION, LOCAL-STORAGE SECTION, and LINKAGE SECTION of the DATA DIVISION. When both XREF data and an embedded MAP summary are on the same line, the embedded MAP summary is listed first.

“Example: MAP output” on page 400

RELATED CONCEPTS

Chapter 19, “Debugging,” on page 385

RELATED TASKS

“Getting listings” on page 395

RELATED REFERENCES

*CONTROL (*CBL) statement (*Enterprise COBOL Language Reference*)

MAXPCF

Use the MAXPCF option to specify a maximum program complexity factor value. The program complexity factor (PCF) is computed by the compiler and the computed value is in the listing file. If the PCF of your program exceeds the maximum value, the compiler will automatically reduce the optimization level to speed up the compilation and use less storage. Therefore, when you compile a suite of programs, you do not have to specify an OPTIMIZE option value for each program.

MAXPCF option syntax

▶▶—MAXPCF(*n*)—————▶▶

Default is: MAXPCF(60000)

Abbreviations are: None

n must be an integer of 0 - 999999.

The aspects of the program taken into consideration when computing the complexity factor include:

- The number of COBOL statements in the PROCEDURE DIVISION, including generated statements from the CICS, SQL or SQLIMS options, and the expansion of COPY and REPLACE statements
- Initialization operations for WORKING-STORAGE or LOCAL-STORAGE data items with value clauses
- Operations for variable-length groups or subgroups in the DATA DIVISION, which compute their size at run time

Note: PCF is not a metric to measure how complex a program is. It is merely a count of COBOL items that can cause problems for optimization when there are a lot of them. To measure program complexity, you should use something like the Metrics feature provided by IBM Developer for z Systems®.

For large and complex programs, you can use the MAXPCF option to set a threshold on the program complexity that the compiler attempts optimize. Lower the MAXPCF value to reduce the optimization level, hence the compiler needs less memory and compilation time. Raise the MAXPCF value to attempt to optimize the programs at the cost of longer compilation time.

If you specify MAXPCF(0), no limit is enforced on the complexity of the program, and the MAXPCF option has no effect.

If you specify MAXPCF(n) and n is not zero, when the program complexity factor exceeds n , any specification of OPTIMIZE(1) or OPTIMIZE(2) is reset to OPTIMIZE(0), and a warning message is generated.

If the COBOL source file contains a sequence of source programs (a batch compile), the MAXPCF limit is applied on a per program basis.

Notes:

- If the OPTIMIZE(1) or OPTIMIZE(2) option is set at installation time as a fixed, nonoverridable option, then MAXPCF(n) with a nonzero n is an option conflict. In this case, the OPTIMIZE option takes precedence and the MAXPCF(0) option is forced on.
- If you attempt to optimize a program larger than the default threshold by raising the value of MAXPCF to n where n is greater than the default, or by specifying MAXPCF(0), the compiler might take excessive time to compile or fail to compile because of insufficient memory.

RELATED REFERENCES

“OPTIMIZE” on page 346

MDECK

The MDECK compiler option specifies that a copy of the updated input source after library processing (that is, the result of COPY, BASIS, REPLACE, EXEC SQL INCLUDE, and EXEC SQLIMS INCLUDE statements) is written to a file.

If Enterprise COBOL is running under z/OS UNIX, the MDECK output is written in the current directory to a file that has the same name as the COBOL source file and a suffix of .dek. For Enterprise COBOL running under TSO or batch, the MDECK output is written to the data set defined by the SYSMDECK DD allocation, which must specify an MVS data set that has RECFM F or FB and an LRECL of 80 bytes.

Note: When compiling under z/OS TSO or batch, the COBOL compiler requires the SYSMDECK data set allocation for all compilations, no matter if you specify the MDECK or NOMDECK option:

- If you specify the MDECK option, the SYSMDECK DD allocation must specify a permanent data set.
- If you specify the NOMDECK option, the SYSMDECK DD allocation can specify either a temporary utility data set or a permanent data set.

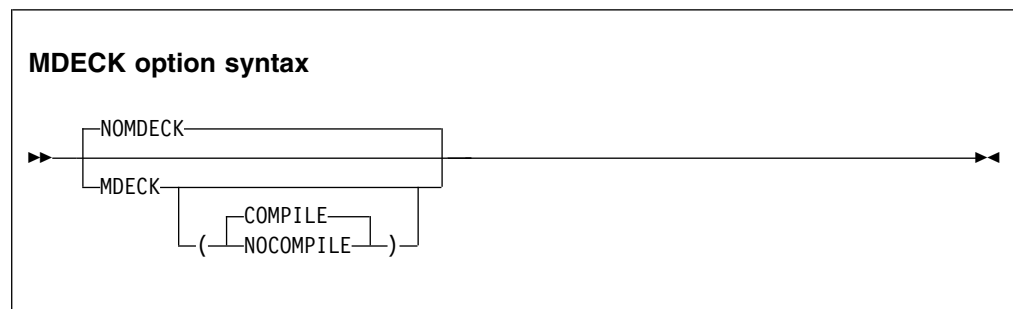

Default is: NOMDECK

Abbreviations are: NOMD|MD|MD(C|NOC)

Option specification:

You cannot specify the MDECK option in a PROCESS (or CBL) statement. You can specify it only in one of the following ways:

- In the PARM parameter of JCL
- As a cob2 command option
- As an installation default
- In the **COBOPT** environment variable

Suboptions:

- When MDECK(COMPILE) is in effect, compilation continues normally after library processing and generation of the MDECK output file have completed, subject to the settings of the COMPILE|NOCOMPILE, DECK|NODECK, and OBJECT|NOOBJECT compiler options.
- When MDECK(NOCOMPILE) is in effect, compilation is terminated after library processing has completed and the expanded source program file has been written. The compiler does no further syntax checking or code generation regardless of the settings of the COMPILE, DECK, and OBJECT compiler options.

If you specify MDECK with no suboption, MDECK(COMPILE) is implied.

Contents of the MDECK output file:

If you use the MDECK option with programs that contain EXEC CICS, EXEC SQL, or EXEC SQLIMS statements, these EXEC statements are included in the MDECK output as is. However, if you compile using the SQL or SQLIMS option, the corresponding EXEC SQL INCLUDE or EXEC SQLIMS INCLUDE statements are expanded in the MDECK output.

CBL, PROCESS, *CONTROL, and *CBL card images are passed to the MDECK output file in the proper locations.

For a batch compilation (multiple COBOL source programs in a single input file), a single MDECK output file that contains the complete expanded source is created.

Any SEQUENCE compiler-option processing is reflected in the MDECK file.

COPY statements are included in the MDECK file as comments.

RELATED TASKS

“Starting the compiler from an assembler program” on page 265

“Defining the library-processing output file (SYSMDECK)” on page 272

RELATED REFERENCES

“Conflicting compiler options” on page 304

Chapter 18, “Compiler-directing statements,” on page 381

NAME

Use NAME to generate a link-edit NAME card for each object module. You can also use NAME to generate names for each program object when you are doing batch compilations.

When NAME is specified, a NAME card is appended to each object module that is created. Program object names are formed using the rules for forming module names from PROGRAM-ID statements.

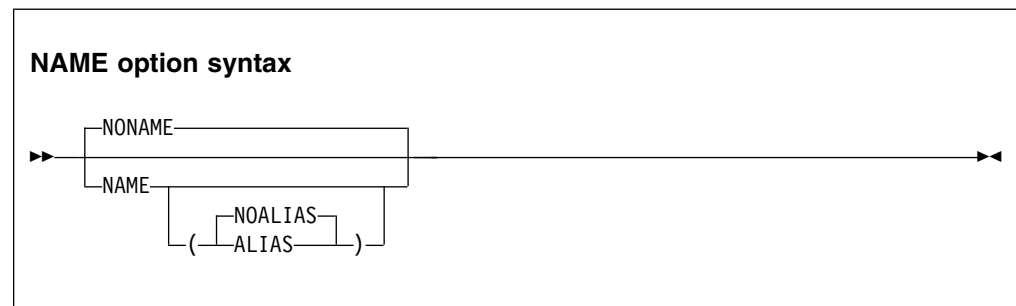

Default is: NONAME, or NAME(NOALIAS) if only NAME is specified

Abbreviations are: None

If you specify NAME(ALIAS), and your program contains ENTRY statements, a link-edit ALIAS card is generated for each ENTRY statement.

RELATED REFERENCES

PROGRAM-ID paragraph (*Enterprise COBOL Language Reference*)

NSYMBOL

The NSYMBOL option controls the interpretation of the N symbol used in literals and PICTURE clauses, indicating whether national or DBCS processing is assumed.

NSYMBOL option syntax

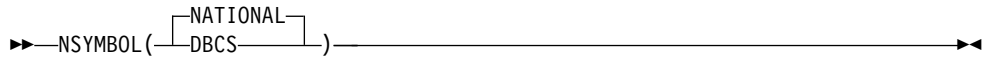

Diagram illustrating the NSYMBOL option syntax: NSYMBOL (NATIONAL | DBCS)

Default is: NSYMBOL(NATIONAL)

Abbreviations are: NS(NAT|DBCS)

With NSYMBOL(NATIONAL):

- Data items defined with a PICTURE clause that consists only of the symbol N without the USAGE clause are treated as if the USAGE NATIONAL clause is specified.
- Literals of the form N". . ." or N'. . .' are treated as national literals.

With NSYMBOL(DBCS):

- Data items defined with a PICTURE clause that consists only of the symbol N without the USAGE clause are treated as if the USAGE DISPLAY-1 clause is specified.
- Literals of the form N". . ." or N'. . .' are treated as DBCS literals.

The NSYMBOL(DBCS) option provides compatibility with previous releases of IBM COBOL, and the NSYMBOL(NATIONAL) option makes the handling of the above language elements consistent with the 2002 COBOL Standard in this regard.

NSYMBOL(NATIONAL) is recommended for applications that use Unicode data or object-oriented syntax for Java interoperability.

RELATED REFERENCES

"Conflicting compiler options" on page 304

NUMBER

Use the NUMBER compiler option if you have line numbers in your source code and want those numbers to be used in error messages and SOURCE, MAP, LIST, and XREF listings.

NUMBER option syntax

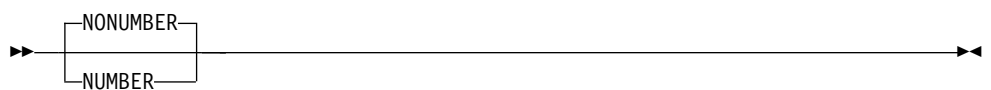

Diagram illustrating the NUMBER option syntax: NUMBER | NONUMBER

Default is: NONUMBER

Abbreviations are: NUM | NONUM

If you request NUMBER, the compiler checks columns 1 through 6 to make sure that they contain only numbers and that the numbers are in numeric collating sequence. (In contrast, SEQUENCE checks the characters in these columns according to EBCDIC collating sequence.) When a line number is found to be out of sequence, the compiler assigns to it a line number with a value one higher than the line number of the preceding statement. The compiler flags the new value with two asterisks and includes in the listing a message indicating an out-of-sequence error. Sequence-checking continues with the next statement, based on the newly assigned value of the previous line.

If you use COPY statements and NUMBER is in effect, be sure that your source program line numbers and the copybook line numbers are coordinated.

If you are doing a batch compilation and NUMBER is in effect, all programs in the batch compile will be treated as a single input file. The sequence numbers of the entire input file must be in ascending order.

Use NONUMBER if you do not have line numbers in your source code, or if you want the compiler to ignore the line numbers you do have in your source code. With NONUMBER in effect, the compiler generates line numbers for your source statements and uses those numbers as references in listings.

NUMCHECK

The NUMCHECK compiler option tells the compiler whether to generate extra code to validate data items when they are used as sending data items. For zoned decimal (numeric USAGE DISPLAY) and packed decimal (COMP-3) data items, the compiler generates implicit numeric class tests for each sending field. For binary data items, the compiler generates SIZE ERROR checking to see whether the data item has more digits than its PICTURE clause allows.

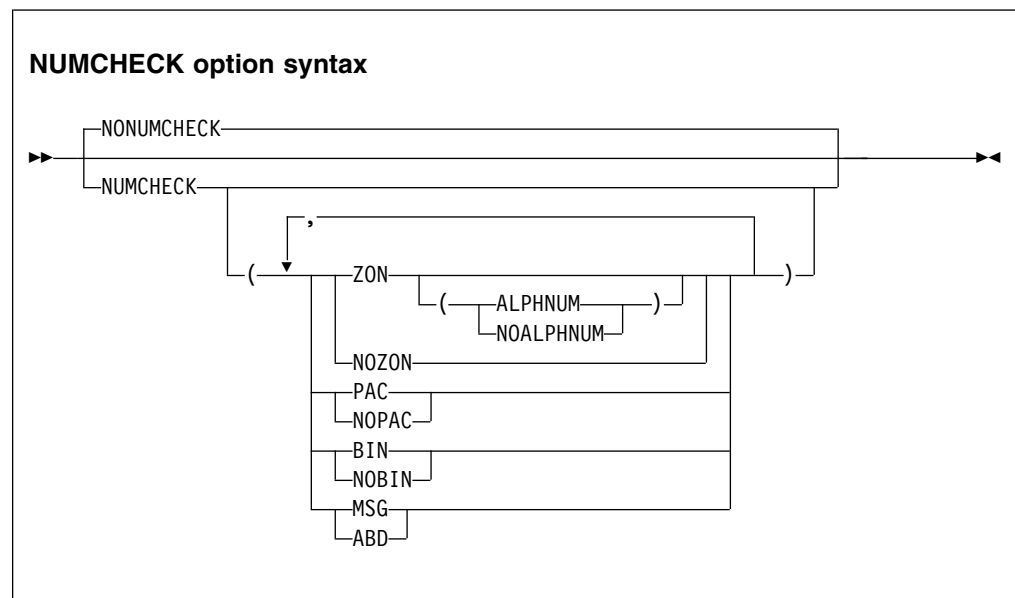

Default is: NONUMCHECK

Suboption defaults are:

- If no suboption is specified, defaults are ZON(ALPHNUM), PAC, BIN and MSG. For example, NUMCHECK has the same effect as NUMCHECK(ZON(ALPHNUM),PAC,BIN,MSG).
- If no datatype suboption is specified, default datatype suboptions are ZON(ALPHNUM), PAC, and BIN. For example, NUMCHECK(ABD) has the same effect as NUMCHECK(ZON(ALPHNUM),PAC,BIN,ABD).
- If only one datatype suboption is specified, defaults are NOZON, NOPAC, NOBIN, and MSG. For example, NUMCHECK(BIN) has the same effect as NUMCHECK(NOZON,NOPAC,BIN,MSG).
- If all datatype suboptions are specified with NO, then the listing will show NONUMCHECK. For example, NUMCHECK(NOZON,NOPAC,NOBIN) has the same effect as NONUMCHECK.

Abbreviations are: NONC | NC

ZON [(ALPHNUM | NOALPHNUM)] | NOZON

Specifying ZON or ZON(ALPHNUM) causes the compiler to generate code for an implicit numeric class test for zoned decimal (numeric USAGE DISPLAY) data items that are used as sending data items in COBOL statements.

Specifying ZON(NOALPHNUM) causes the compiler to generate code for an implicit numeric class test for zoned decimal (numeric USAGE DISPLAY) data items that are used as sending data items in COBOL statements, except when they are used in a comparison with an alphanumeric data item, alphanumeric literal or alphanumeric figurative constant.

Receivers are not checked, unless they are both a sender and a receiver, such as data item B in the following sample statements:

```
ADD A TO B
DIVIDE A INTO B
COMPUTE B = A + B
INITIALIZE B REPLACING ALPHANUMERIC BY B
```

This checking is done before the data is used in each statement:

- If the data is NOT NUMERIC, either a warning message for NUMCHECK(ZON,MSG) or a terminating message for NUMCHECK(ZON,ABD) is issued.
- If the data is NUMERIC, the external behavior of the statement is the same as NUMCHECK(NOZON), other than being slower.

PAC | NOPAC

Specifying PAC causes the compiler to generate code for an implicit numeric class test for packed decimal (COMP-3) data items that are used as sending data items in COBOL statements. For packed decimal data items that have an even number of digits, the unused bits are checked for ones.

Restriction: For CALL statements, NUMCHECK(ZON) and NUMCHECK(PAC) check BY CONTENT data items that are zoned decimal or packed decimal, but they do not check BY REFERENCE parameters. (Neither zoned decimal nor packed decimal data items can be specified in a BY VALUE phrase.)

BIN | NOBIN

When TRUNC(OPT) or TRUNC(STD) is in effect, specifying NUMCHECK(BIN) causes the compiler to generate code similar to ON SIZE ERROR to test if

binary data items contents are bigger than the PICTURE clause. This extra code will be generated only for binary data items that are used as sending data items, and COMP-5 data items will not get this ON SIZE ERROR code generated.

NUMCHECK(BIN) has no effect if TRUNC(BIN) is in effect.

MSG | ABD

Determines whether the message issued for invalid data is a warning level message to continue processing or a terminating level message to cause an abend:

- If MSG is in effect, a runtime warning message with the line number, data item name, data item content, and program name is issued.
- If ABD is in effect, a terminating message is issued that causes an abend.

Performance considerations: NUMCHECK is much slower than NONUMCHECK, depending on how many zoned decimal (numeric USAGE DISPLAY) data items, packed decimal (COMP-3) data items, and binary data items are used in a COBOL program.

Note: In Enterprise COBOL V5.2 with PTF for APAR PI81006 installed, ZONECHECK is deprecated but is tolerated for compatibility, and it is replaced by NUMCHECK(ZON(ALPHNUM)).

RELATED TASKS

“Checking for incompatible data (numeric class test)” on page 54

RELATED REFERENCES

“NUMPROC”

“TRUNC” on page 368

“ZONECHECK” on page 375

“ZONEDATA” on page 377

NUMPROC

Use NUMPROC(NOPFD) if your internal decimal and zoned decimal data might use nonpreferred signs.

NUMPROC option syntax

►► NUMPROC (NOPFD
PFD) ◄◄

Default is: NUMPROC(NOPFD)

Abbreviations are: None

The compiler accepts any valid sign configuration: X'A', X'B', X'C', X'D', X'E', or X'F'. NUMPROC(NOPFD) is the recommended option in most cases.

Performance considerations: NUMPROC(PFD) improves the performance of processing internal decimal and zoned decimal data. Use this option however only if your numeric data agrees exactly with the following IBM system standards:

- **Zoned decimal, unsigned:** High-order 4 bits of the sign byte contain X'F'.
- **Zoned decimal, signed overpunch:** High-order 4 bits of the sign byte contain X'C' if a number is positive or 0, and X'D' if it is not.
- **Zoned decimal, separate sign:** Separate sign contains the character '+' if a number is positive or 0, and '-' if it is not.
- **Internal decimal, unsigned:** Low-order 4 bits of the low-order byte contain X'F'.
- **Internal decimal, signed:** Low-order 4 bits of the low-order byte contain X'C' if a number is positive or 0, and X'D' if it is not.

Data produced by COBOL arithmetic statements conforms to the IBM system standards described above. However, using REDEFINES and group moves could change data so that it no longer conforms. If you use NUMPROC(PFD), use the INITIALIZE statement to initialize data fields, rather than using group moves.

Using NUMPROC(PFD) can affect class tests for numeric data. Use NUMPROC(NOPFD) if a COBOL program calls programs written in PL/I or FORTRAN.

Sign representation is affected not only by the NUMPROC option, but also by the NUMCLS installation option.

RELATED TASKS

“Checking for incompatible data (numeric class test)” on page 54

RELATED REFERENCES

“Sign representation of zoned and packed-decimal data” on page 53

OBJECT

Use OBJECT to write the generated object code to a file to be used as input for the binder.

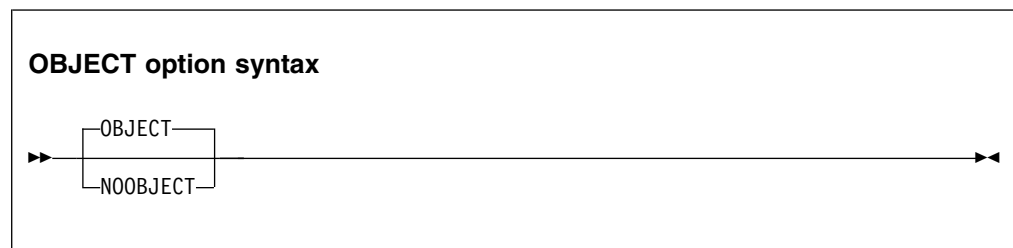

Default is: OBJECT

Abbreviations are: OBJ | NOOBJ

If you specify OBJECT, include a SYSLIN DD statement in your JCL for compilation.

The only difference between DECK and OBJECT is in the routing of output to the data sets:

- DECK output goes to the data set associated with ddname SYSPUNCH.
- OBJECT output goes to the data set associated with ddname SYSLIN.

Use the option that your installation guidelines recommend.

RELATED REFERENCES

“Conflicting compiler options” on page 304

OFFSET

Use `OFFSET` to produce a condensed `PROCEDURE DIVISION` listing.

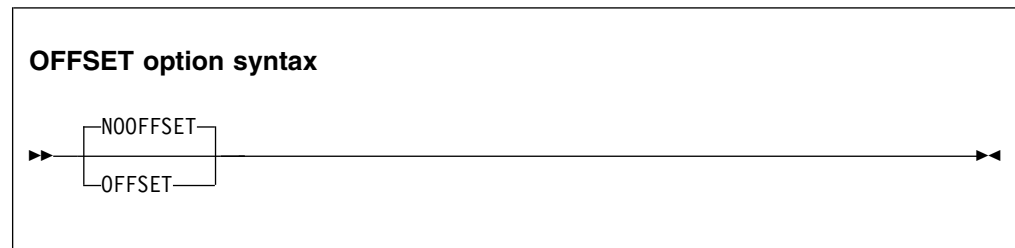

Default is: `NOOFFSET`

Abbreviations are: `OFF` | `NOOFF`

With `OFFSET`, the condensed `PROCEDURE DIVISION` listing will contain line numbers, statement references, and the location of the first instruction generated for each statement. In addition, the listing also shows:

- Global tables
- Literal pools
- Size of the program's `WORKING-STORAGE`, and its location in the object code if the program is compiled with the `NORENT` option

RELATED REFERENCES

“Conflicting compiler options” on page 304

OPTFILE

Use `OPTFILE` to enable the specifying of COBOL compiler options in a data set. Using a compiler-option data set circumvents the 100-character limit on options specified in a `JCL PARM` string.

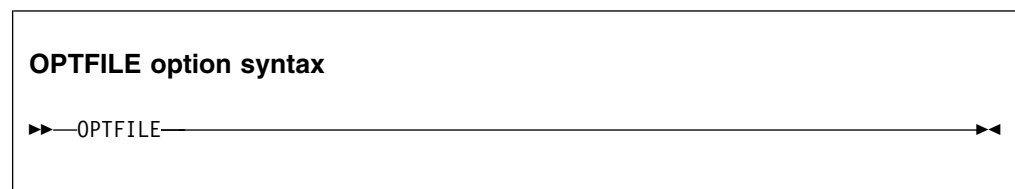

Default is: None

Abbreviations are: None

You can specify OPTFILE as a compiler invocation option or in the PROCESS or CBL statement in your COBOL source program. OPTFILE cannot be specified as an installation default.

OPTFILE is ignored if you compile using the cob2 command in the z/OS UNIX environment. (In that environment, the COBOPT environment variable provides a capability that is comparable to OPTFILE.)

If OPTFILE is in effect, compiler options are read from the data set that you identify in a SYSOPTF DD statement. A SYSOPTF data set must have RECFM F or FB and an LRECL of 80 bytes. For further details about the format of a SYSOPTF data set, see the related task below about defining a compiler-option data set.

The precedence of options in the SYSOPTF data set is determined by where you specify the OPTFILE option. For example, if you specify OPTFILE in the invocation PARM string, an option specified later in the PARM string supersedes any option specified in the SYSOPTF data set that conflicts with it.

(Conceptually, OPTFILE in an options specification is replaced with the options that are in the SYSOPTF data set; then the usual rules about precedence of compiler options and conflicting compiler options apply.)

If you start the COBOL compiler from within an assembler program, you can use the alternate ddname list to specify a ddname to be used instead of SYSOPTF to identify the compiler-option data set.

RELATED TASKS

“Starting the compiler from an assembler program” on page 265

“Defining a compiler-option data set (SYSOPTF)” on page 269

“Specifying compiler options under z/OS” on page 272

Chapter 15, “Compiling under z/OS UNIX,” on page 283

RELATED REFERENCES

“Conflicting compiler options” on page 304

OPTIMIZE

Use OPTIMIZE to reduce the run time of your object program. Optimization might also reduce the amount of storage your object program uses.

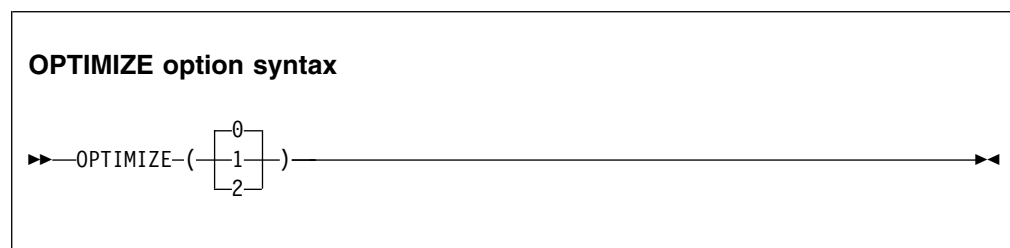

Default is: OPTIMIZE(0)

Abbreviations are: OPT(0), OPT(1), or OPT(2)

Optimizations are performed under the assumption that the program and data are valid, given the compiler options. For example, external decimal data that has USAGE DISPLAY must be valid unless ZONEDATA(MIG) is used to allow invalid zone bits for comparisons. If the program or data is invalid, programs might behave differently at different levels of optimization or between different versions of Enterprise COBOL.

- OPTIMIZE(0) specifies limited optimizations, which result in the shortest compilation time. When the TEST option is specified, full debug capabilities are available.
- OPTIMIZE(1) specifies optimizations that improve application runtime performance. Optimizations at this level include basic inlining, strength reduction, simplification of complex operations into equivalent simpler operations, removal of some unreachable code and block rearrangement. Also, OPTIMIZE(1) includes some intrablock optimizations such as common subexpression elimination and value propagation. When the TEST option is specified, most debug capabilities are available.
- OPTIMIZE(2) specifies further optimizations, which include more aggressive simplifications and instruction scheduling. Also, some interblock optimizations such as global value propagation and loop invariant code motion are included. When the TEST option is specified, some debug capabilities are available.

When OPTIMIZE(1) or OPTIMIZE(2) is used without the TEST compiler option, care must be taken with user-written condition handlers registered via the Language Environment service CEEHDLR. In particular, if a condition handler accesses data items that are not defined local to the condition handler program themselves (for example, data items defined in the application as EXTERNAL), such data items must be defined with the VOLATILE clause to ensure that the handler uses the latest value of the data item, or the condition handler program can be compiled with the TEST compiler option. The use of the VOLATILE clause is preferred over the use of the TEST option because the use of the TEST option can reduce optimization for the entire program, while VOLATILE localizes the reduced optimization.

For more information about the VOLATILE clause, see VOLATILE clause in the *Enterprise COBOL Language Reference*.

Note: In Enterprise COBOL V5, the NOOPTIMIZE, OPTIMIZE, OPTIMIZE(STD), and OPTIMIZE(FULL) options are removed but are tolerated for compatibility. If one of those options is specified, it is mapped to the new option or options as follows:

Table 48. Mapping of removed options to new options

Removed options	New options
NOOPTIMIZE	OPTIMIZE(0)
OPTIMIZE	OPTIMIZE(1)
OPTIMIZE(STD)	OPTIMIZE(1)
OPTIMIZE(FULL)	OPTIMIZE(1) and STGOPT

RELATED CONCEPTS

“Optimization” on page 667

RELATED TASKS

“Writing routines for handling errors” on page 250

RELATED REFERENCES

“Conflicting compiler options” on page 304

“MAXPCF” on page 336

“TEST” on page 364

“STGOPT” on page 362

VOLATILE clause (*Enterprise COBOL Language Reference*)

OUTDD

Use OUTDD to specify that you want DISPLAY output that is directed to the system logical output device to go to a specific ddname.

You can specify a file in the z/OS UNIX file system with the ddname named in OUTDD. To understand where output is directed when this ddname is not allocated, see the related task about displaying data.

OUTDD option syntax

▶▶—OUTDD(*ddname*)—————▶▶

Default is: OUTDD(SYSOUT)

Abbreviations are: OUT

If the OUTDD compiler option and the Language Environment MSGFILE runtime option specify the same ddname (both default to SYSOUT), DISPLAY output to the system logical output device is written using Language Environment message facilities.

Restriction: The OUTDD option has no effect under CICS.

RELATED TASKS

“Displaying data on the system logical output device” on page 36

“Coding COBOL programs to run under CICS” on page 429

RELATED REFERENCES

Language Environment Programming Reference (MSGFILE)

PGMNAME

The PGMNAME option controls the handling of program-names and entry-point names.

PGMNAME option syntax

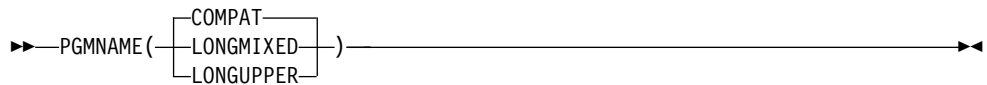

Default is: PGMNAME (COMPAT)

Abbreviations are: PGMN (LM | LU | CO)

LONGUPPER can be abbreviated as UPPER, LU, or U. LONGMIXED can be abbreviated as MIXED, LM, or M.

PGMNAME controls the handling of names used in the following contexts:

- Program-names defined in the PROGRAM-ID paragraph
- Program entry-point names in the ENTRY statement
- Program-name references in:
 - CALL statements that reference nested programs, statically linked programs, or DLLs
 - SET *procedure-pointer* or *function-pointer* statements that reference statically linked programs or DLLs
 - CANCEL statements that reference nested programs

PGMNAME (COMPAT)

With PGMNAME (COMPAT), program-names are handled in a manner compatible with older versions of COBOL compilers:

- The program-name can be up to 30 characters in length.
- All the characters used in the name must be alphabetic, digits, the hyphen, or the underscore, except that if the program-name is a literal and is in the outermost program, then the literal can also contain the extension characters @, #, and \$, and the first character can be an underscore.
- At least one character must be alphabetic.
- The hyphen cannot be used as the first or last character.

External program-names are processed by the compiler as follows:

- They are folded to uppercase.
- They are truncated to eight characters.
- Hyphens are translated to zero (0).
- If the first character is not alphabetic, and is not an underscore, it is converted as follows:
 - 1-9 are translated to A-I.
 - Anything else is translated to J.

PGMNAME (LONGUPPER)

With PGMNAME (LONGUPPER), program-names that are specified in the PROGRAM-ID paragraph as COBOL user-defined words must follow the normal COBOL rules for forming a user-defined word:

- The program-name can be up to 30 characters in length.

- All the characters used in the name must be alphabetic, digits, the hyphen, or the underscore.
- At least one character must be alphabetic.
- The hyphen cannot be used as the first or last character.
- The underscore cannot be used as the first character.

When a program-name is specified as a literal, in either a definition or a reference, then:

- The program-name can be up to 160 characters in length.
- All the characters used in the name must be alphabetic, digits, the hyphen, or the underscore.
- At least one character must be alphabetic.
- The hyphen cannot be used as the first or last character.
- The underscore can be used in any position.

External program-names are processed by the compiler as follows:

- They are folded to uppercase.
- Hyphens are translated to zero (0).
- If the first character is not alphabetic, and is not an underscore, it is converted as follows:
 - 1-9 are translated to A-I.
 - Anything else is translated to J.

Names of nested programs are folded to uppercase by the compiler but otherwise are processed as is, without truncation or translation.

PGMNAME(LONGMIXED)

With PGMNAME(LONGMIXED), program-names are processed as is, without truncation, translation, or folding to uppercase.

With PGMNAME(LONGMIXED), all program-name definitions must be specified using the literal format of the program-name in the PROGRAM-ID paragraph or ENTRY statement. The literal user for a program-name can contain any character in the range X'41'-X'FE'.

Usage notes

- The following elements are not affected by the PGMNAME option:
 - Class-names and method-names.
 - System-names (assignment-names in SELECT . . . ASSIGN, and text-names or library-names in COPY statements).
 - Dynamic calls.

Dynamic calls are resolved with truncation of the program-name to eight characters, folding to uppercase, and translation of embedded hyphens or a leading digit.
 - CANCEL of nonnested programs. Name resolution uses the same mechanism as for a dynamic call.
- **Link-edit considerations:** COBOL programs that are compiled with the PGMNAME(LONGUPPER) or PGMNAME(LONGMIXED) option must be link-edited in AMODE 31.

- Dynamic calls are not permitted to COBOL programs compiled with the PGMNAME(LONGMIXED) or PGMNAME(LONGUPPER) options unless the program-name is less than or equal to 8 bytes, and all uppercase. In addition, the name of the program must be identical to the name of the module that contains it.
- When using the extended character set supported by PGMNAME(LONGMIXED), be sure to use names that conform to the binder (linkage-editor) or system conventions that apply, depending on the mechanism used to resolve the names. Using characters such as commas or parentheses is not recommended, because these characters are used in the syntax of binder (linkage-editor) control statements.

RELATED REFERENCES

PROGRAM-ID paragraph (*Enterprise COBOL Language Reference*)

QUALIFY

QUALIFY affects qualification rules and controls whether to extend qualification rules so that some data items that cannot be referenced under COBOL Standard rules can be referenced.

QUALIFY option syntax

►► QUALIFY (COMPAT
EXTEND) ◀◀

Default is: QUALIFY(COMPAT)

Abbreviations are: QUA(C|E)

QUALIFY(COMPAT)

If QUALIFY(COMPAT) is in effect, references to data items must be unique.

QUALIFY(EXTEND)

If QUALIFY(EXTEND) is in effect, qualification rules are extended so that some references that are not unique by COBOL standard rules can be unique. If every level in the containing hierarchy of names is specified, the set of qualifiers is called a *complete set of qualifiers*. If there is only one data item with a specific complete set of qualifiers, the reference resolves to that data item, even if the same set of qualifiers can match with another reference as an incomplete set of qualifiers.

Example

```
01 A.
  02 B.
    03 C PIC X.
    03 A PIC X.
  02 C PIC X.
.
.
.
Move space to C of A      *> Refers to 02 level C (unique only with QUALIFY(EXTEND))
Move space to A          *> Refers to 01 level A (unique only with QUALIFY(EXTEND))
Move space to C of B of A *> Refers to 03 level C (unique by COBOL standard rules)
Move space to C of B      *> Refers to 03 level C (unique by COBOL standard rules)
```

QUOTE/APOST

Use QUOTE if you want the figurative constant [ALL] QUOTE or [ALL] QUOTES to represent one or more quotation mark (") characters. Use APOST if you want the figurative constant [ALL] QUOTE or [ALL] QUOTES to represent one or more single quotation mark (') characters.

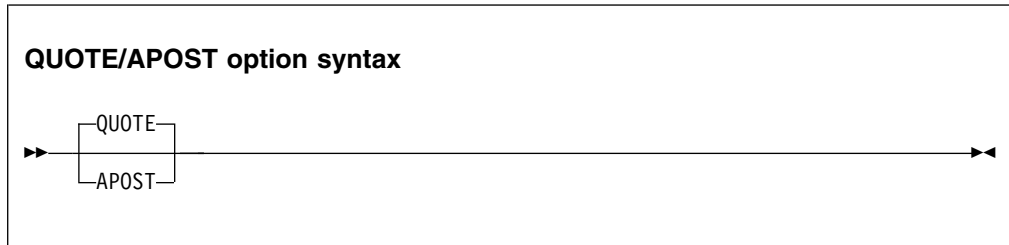

Default is: QUOTE

Abbreviations are: Q|APOST

Delimiters: You can use either quotation marks or single quotation marks as literal delimiters regardless of whether the APOST or QUOTE option is in effect. The delimiter character used as the opening delimiter for a literal must be used as the closing delimiter for that literal.

RENT

A program compiled as RENT is generated as a reentrant object program. A program compiled as NORENT is generated as a nonreentrant object program.

Either a reentrant or a nonreentrant program can be invoked as a main program or as a subprogram.

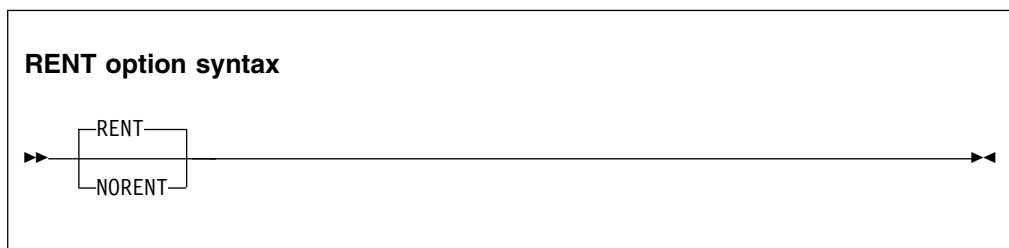

Default is: RENT

Abbreviations are: None

DATA and RMODE settings: The RENT option interacts with other compiler options that affect storage and its addressability. Use the DATA(24|31) option for reentrant programs to control whether dynamic data areas are allocated in unrestricted storage or in storage obtained from below 16 MB. Compile programs with RENT if they will be run in virtual storage addresses above 16 MB.

Execution of nonreentrant programs above 16 MB is not supported. Programs compiled with NORENT must be RMODE 24.

The setting of the DATA option does not affect programs compiled with NORENT.

For information about which Enterprise COBOL programs need to be reentrant, see the related task about making programs reentrant.

Link-edit considerations: If all programs in a program object are compiled with RENT, it is recommended that the program object be link-edited with the RENT binder (linkage-editor) option. Use the REUS binder (linkage-editor) option instead if the program object will also contain any non-COBOL programs that are only serially reusable.

If any program in a program object is not reentrant, the program object must not be link-edited with the RENT or REUS link-edit attributes. The NOREUS binder (linkage-editor) option is needed to ensure that the CANCEL statement will guarantee a fresh copy of the program on a subsequent CALL.

RELATED CONCEPTS

“Storage and its addressability” on page 39

RELATED TASKS

“Making programs reentrant” on page 490

DB2 Application Programming and SQL Guide (Using reentrant code)

RELATED REFERENCES

“Conflicting compiler options” on page 304

“RMODE”

RMODE

The RMODE setting influences the RMODE (residency mode) of your generated object program.



Default is: AUTO

Abbreviations are: None

A program compiled with the RMODE(AUTO) option will have RMODE 24 if NORENT is specified, or RMODE ANY if RENT is specified. RMODE AUTO is compatible with older compilers such as VS COBOL II, which produced RMODE 24 for programs compiled with NORENT, and RMODE ANY for programs compiled with RENT.

A program compiled with the RMODE(24) option will have RMODE 24 whether NORENT or RENT is specified.

A program compiled with the RMODE(ANY) option must also be compiled with the RENT option. The program will have the RMODE ANY attribute.

If the NORENT option is specified, the RMODE(24) or RMODE(AUTO) compiler option must be specified. Overriding the module RMODE with a binder option or control statement is not supported.

DATA and RENT: The RMODE option interacts with other compiler options and runtime options that affect storage and its addressability. For information about passing data between programs with different modes, see the related concept about storage and its addressability.

Link-edit considerations: If the object code that COBOL generates has an attribute of RMODE 24, you must link-edit the code with RMODE 24. If the object code that COBOL generates has an attribute of RMODE ANY, you can link-edit the code with either RMODE ANY or RMODE 24.

RELATED CONCEPTS

“Storage and its addressability” on page 39

RELATED REFERENCES

“Allocation of buffers for QSAM files” on page 181

“Conflicting compiler options” on page 304

RULES

You can use the RULES option to request information about your program from the compiler to improve the program by flagging certain types of source code at compile time.

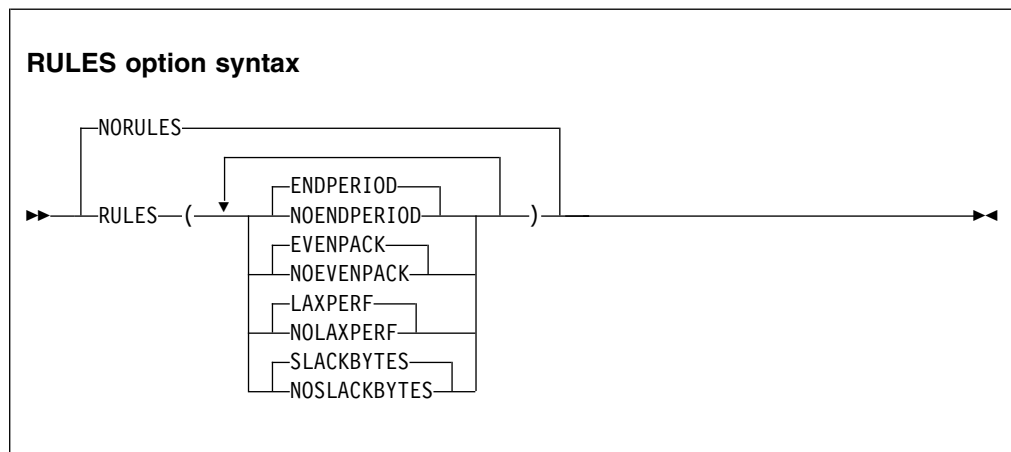

Default is: NORULES

Abbreviations are:

- ENDP = ENDPERIOD
- EVENP = EVENPACK

- LXPRF = LAXPERF
- SLCKB = SLACKBYTES

You can specify the following suboptions for RULES:

ENDPERIOD | NOENDPERIOD

The default is ENDPERIOD. Specifying NOENDPERIOD causes the compiler to issue warning messages when the scope of a conditional statement is terminated by a period instead of an explicit scope terminator END-*.

EVENPACK | NOEVENPACK

The default is EVENPACK. Specifying NOEVENPACK causes the compiler to issue warning messages for any USAGE PACKED-DECIMAL (COMP-3) data items that have an even number of digits because those data items whose unused bits are not zero can lead to an unexpected program behavior.

Note: RULES(NOEVERPACK) helps compilers to identify even-length USAGE PACKED-DECIMAL (COMP-3) data items. However, it is not necessary to change those data items to odd-length items when the related database schema uses even-length packed values.

LAXPERF | NOLAXPERF

The default is LAXPERF. Specifying NOLAXPERF suboption causes the compiler to issue warning messages for usage of inefficient COBOL features. These features might include USAGE DISPLAY numeric data items in arithmetic statements, large amounts of space padding in MOVE statements, inefficient compiler options, and other cases.

SLACKBYTES | NOSLACKBYTES

The default is SLACKBYTES. Specifying NOSLACKBYTES causes the compiler to issue warning messages for any SYNCHRONIZED data items that cause the compiler to add slack bytes, either slack bytes within records or slack bytes between records. Each data item that causes slack bytes to be added gets a compiler diagnostic.

If the RULES option is specified with no suboptions, the default is RULES(ENDPERIOD,EVENPACK,LAXPERF,SLACKBYTES).

Notes:

- It is not necessary to specify all of the suboptions for RULES. If a suboption is not specified, the default takes effect.
- You can optionally use the RULES option with the MSGEXIT suboption of the EXIT compiler option to enforce local coding standards. For example, if you want to ensure that no programmers use periods instead of explicit scope delimiters to delimit conditional statements, you can change the severity of the ENDPERIOD message from Warning level (RC=4) to Severe level (RC=12). For a sample of how to modify the severity of this and other RULES messages, see the sample MSGEXIT in SIGYSAMP called IGYMSGXT.

RELATED REFERENCES

SYNCHRONIZED clause (Enterprise COBOL Language Reference)

SEQUENCE

When you use `SEQUENCE`, the compiler examines columns 1 through 6 to check that the source statements are arranged in ascending order according to their EBCDIC collating sequence. The compiler issues a diagnostic message if any statements are not in ascending order.

Source statements with blanks in columns 1 through 6 do not participate in this sequence check and do not result in messages.

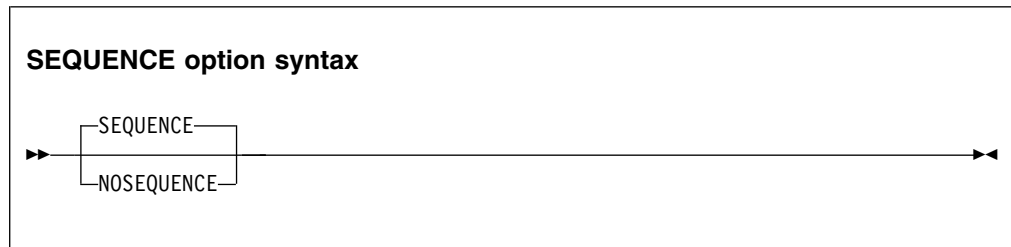

Default is: `SEQUENCE`

Abbreviations are: `SEQ` | `NOSEQ`

If you use `COPY` statements with the `SEQUENCE` option in effect, be sure that your source program's sequence fields and the copybook sequence fields are coordinated.

If you use `NUMBER` and `SEQUENCE`, the sequence is checked according to numeric, rather than EBCDIC, collating sequence.

If you are doing a batch compilation and `SEQUENCE` is in effect, all programs in the batch compilation are treated as a single input file. The sequence numbers of the entire input file must be in ascending order.

Use `NOSEQUENCE` to suppress this checking and the diagnostic messages.

RELATED TASKS

"Finding line sequence problems" on page 391

SERVICE

Use `SERVICE` to place a string in the object module if the object module is generated. If the object module is linked into a program object, the string is loaded into memory with this program object. If the Language Environment dump includes a traceback, this string is included in that traceback.

SERVICE option syntax

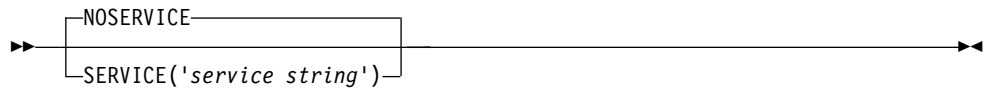

Default is: NOSERVICE

Abbreviations are: SERV | NOSERV

The *service string* is limited to 64 characters in length.

SOURCE

Use SOURCE to get a listing of your source program. This listing will include any statements embedded by PROCESS or COPY statements.

SOURCE option syntax

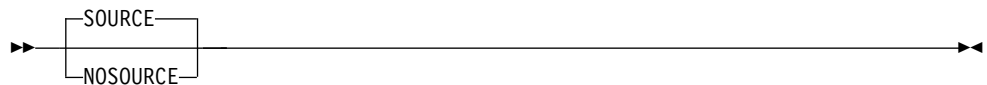

Default is: SOURCE

Abbreviations are: S | NOS

You must specify SOURCE if you want embedded messages in the source listing.

Use NOSOURCE to suppress the source code from the compiler output listing.

If you want to limit the SOURCE output, use *CONTROL SOURCE or NOSOURCE statements in your PROCEDURE DIVISION. Source statements that follow a *CONTROL NOSOURCE statement are not included in the listing until a subsequent *CONTROL SOURCE statement switches the output back to normal SOURCE format.

“Example: MAP output” on page 400

RELATED REFERENCES

*CONTROL (*CBL) statement (*Enterprise COBOL Language Reference*)

SPACE

Use SPACE to select single-, double-, or triple-spacing in your source code listing.

SPACE option syntax

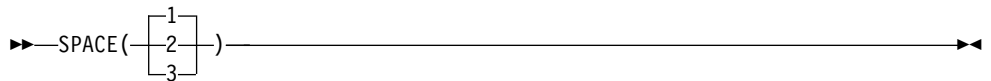

Default is: `SPACE(1)`

Abbreviations are: None

SPACE has meaning only when the SOURCE compiler option is in effect.

RELATED REFERENCES

"SOURCE" on page 357

SQL

Use the SQL compiler option to enable the DB2 coprocessor and to specify DB2 suboptions. You must specify the SQL option if a COBOL source program contains SQL statements (EXEC SQL statements) and the program has not been processed by the DB2 precompiler.

SQL option syntax

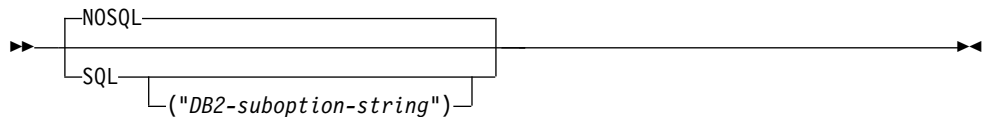

Default is: `NOSQL`

Abbreviations are: None

When you use the SQL option, the DB2 coprocessor writes the database request module (DBRM) to ddname DBRMLIB. DB2 must be available on the machine on which you compile.

If you specify the NOSQL option, any SQL statements found in the source program are diagnosed and discarded.

Use either quotation marks or single quotation marks to delimit the string of DB2 suboptions.

You can partition a long suboption string into multiple suboption strings in multiple CBL statements. For example:

```
//STEP1 EXEC IGYWC, . . .  
// PARM.COBOL='SQL("string1")'  
//COBOL.SYSIN DD *  
    CBL SQL("string2")
```

```
CBL SQL('string3')
IDENTIFICATION DIVISION.
PROGRAM-ID. DRIVER1.
. . .
```

The DB2 suboptions are concatenated in the order of their appearance. Thus in the example above, the compiler passes the following suboption string to the DB2 coprocessor:

```
"string1 string2 string3"
```

The concatenated strings are delimited with single spaces as shown. If multiple instances of the same DB2 option are found, the last specification of each option prevails. The compiler limits the length of the concatenated DB2 suboption string to 4 KB.

RELATED CONCEPTS

"DB2 coprocessor" on page 441

"COBOL and DB2 CCSID determination" on page 447

RELATED TASKS

"Compiling with the SQL option" on page 445

"Separating DB2 suboptions" on page 446

RELATED REFERENCES

"Conflicting compiler options" on page 304

SQLCCSID

Use the SQLCCSID compiler option to control whether the CODEPAGE compiler option will influence the processing of SQL statements in your COBOL programs.

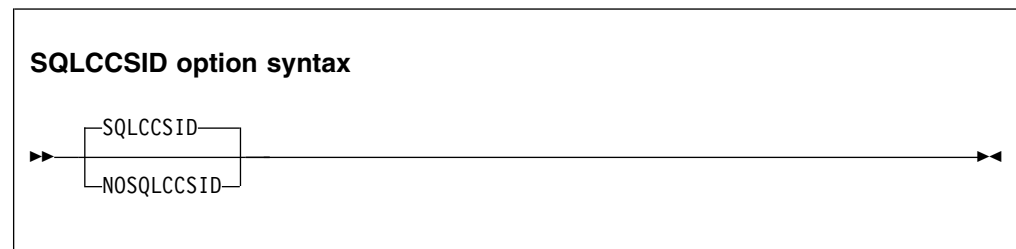

Default is: SQLCCSID

Abbreviations are: SQLC | NOSQLC

The SQLCCSID option has an effect only if you use the integrated DB2 coprocessor (SQL compiler option).

If SQLCCSID is in effect, the setting of the CODEPAGE compiler option will influence the processing of SQL statements within your COBOL programs when you use the integrated DB2 coprocessor. If NOSQLCCSID is in effect, the CODEPAGE setting will not influence the processing of SQL statements when you use the integrated DB2 coprocessor; only COBOL statements will be sensitive to the CCSID specified in the CODEPAGE option.

For further information about this option, see the related task.

RELATED CONCEPTS

"DB2 coprocessor" on page 441

"COBOL and DB2 CCSID determination" on page 447

RELATED TASKS

"Programming with the SQLCCSID or NOSQLCCSID option" on page 448

RELATED REFERENCES

"Code-page determination for string host variables in SQL statements" on page 447

"CODEPAGE" on page 313

"SQL" on page 358

SQLIMS

Use the SQLIMS compiler option to enable the IMS SQL coprocessor and to specify Information Management System (IMS) suboptions. You must specify the SQLIMS option if a COBOL source program contains SQLIMS statements (EXEC SQLIMS statements).

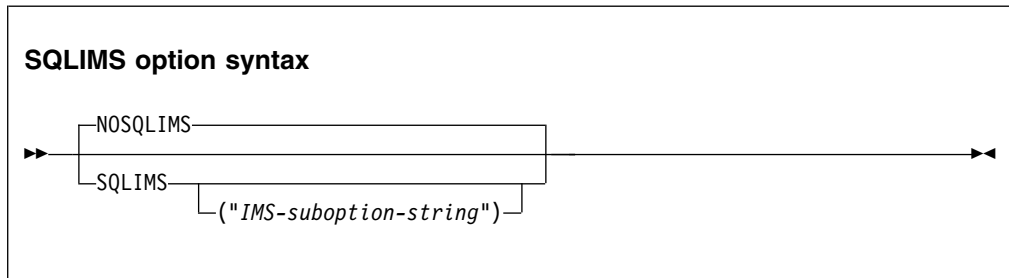

Default: NOSQLIMS

Abbreviation: None

If you specify the NOSQLIMS option, any SQLIMS statements that are found in the source program are diagnosed and discarded.

Use either double quotation marks or single quotation marks to delimit the string of IMS suboptions.

You can partition a long suboption string into multiple suboption strings in multiple CBL statements. For example:

```
//STEP1 EXEC IGYWC, . . .
// PARM.COBOL='SQLIMS("string1")'
//COBOL.SYSIN DD *
    CBL SQLIMS("string2")
    CBL SQLIMS('string3')
    IDENTIFICATION DIVISION.
    PROGRAM-ID. DRIVER1.
    . . .
```

The IMS suboptions are concatenated in the order of their appearance. Thus in the preceding example, the compiler passes the following suboption strings to the IMS SQL coprocessor:

```
"string1 string2 string3"
```

The concatenated strings are delimited with single spaces as shown. If multiple instances of the same IMS suboption are found, the last specification of each suboption takes effect. The compiler limits the length of the concatenated IMS suboption string to 4 KB.

RELATED CONCEPTS

“IMS SQL coprocessor” on page 453

RELATED TASKS

“Compiling with the SQLIMS option” on page 455

“Separating IMS suboptions” on page 456

RELATED REFERENCES

“Conflicting compiler options” on page 304

SSRANGE

Use SSRANGE to generate code that checks for out-of-range storage references.

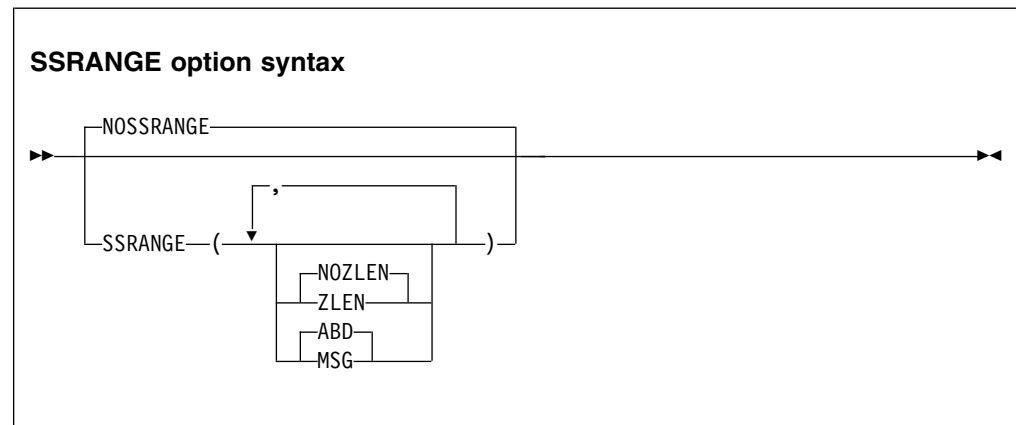

With the PTF for APAR PI53044 installed, new suboptions ZLEN and NOZLEN are added to control how the compiler checks reference modification lengths.

With the PTF for APAR PI86343 installed, new suboptions MSG and ABD are added to control the runtime behavior of the COBOL program when a range check fails.

Default is: NOSSRANGE

Suboption default is: NOZLEN, ABD if only SSRANGE is specified.

Abbreviations are: SSR | NOSSR

SSRANGE generates code that checks whether subscripts, including ALL subscripts, or indexes try to reference areas outside the region of their associated tables. Each subscript or index is not individually checked for validity. Instead, the effective address is checked to ensure that it does not reference outside the table.

If you specify SSRANGE with no suboptions, it will be accepted as a specification of SSRANGE(NOZLEN, ABD).

| **Note:** If the SSRANGE option is in effect, range checks will be generated by the
| compiler and the checks will always be conducted at run time. You cannot disable
| the compiled-in range checks at run time by specifying the runtime option
| CHECK(OFF).

Variable-length items are also checked to ensure that references are within their maximum defined length.

Reference modification expressions are checked to ensure that:

- The starting position is greater than or equal to 1.
- The starting position is not greater than the current length of the subject data item.
- The length value (if specified) is greater than or equal to 1.
- The starting position and length value (if specified) do not reference an area beyond the end of the subject data item.

| The ZLEN and NOZLEN suboptions control how the compiler checks reference
| modification lengths:

- If ZLEN is in effect, the compiler will generate code to ensure that reference modification lengths are greater than or equal to zero. Zero-length reference modification specifications will not get an SSRANGE error at run time.
- If NOZLEN is in effect, the compiler will generate code to ensure that reference modification lengths are greater than or equal to 1. Zero-length reference modification specifications will get an SSRANGE error at run time. This is compatible with how SSRANGE behaved in previous COBOL versions.

| The MSG and ABD suboptions control the runtime behavior of the COBOL program
| when a range check fails.

- If MSG is in effect and a range check fails, a runtime warning message will be issued. This means that the program will continue executing and might potentially identify other out-of-range conditions.
- If ABD is in effect and a range check fails, the first out-of-range condition will result in a runtime error message and the program will ABEND. You can find the next potential out-of-range condition by fixing the first out-of-range condition and then recompiling and running the program again. To identify all other potential out-of-range conditions, you might need to repeat this process several times.

For unbounded groups or their subordinate items, checking is done only for reference modification expressions. Subscripted or indexed references to tables subordinate to an unbounded group are not checked.

RELATED CONCEPTS

"Reference modifiers" on page 113

RELATED TASKS

"Checking for valid ranges" on page 391

STGOPT

The STGOPT option controls storage optimization.

STGOPT option syntax

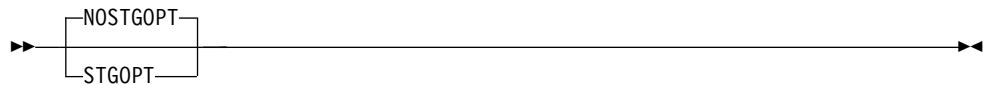

Default is: NOSTGOPT

Abbreviations are: S0, NOS0

If you specify STGOPT, the compiler might discard any or all of the following data items, and does not allocate storage for them.

- Unreferenced LOCAL-STORAGE and non-external WORKING-STORAGE level-77 and level-01 elementary data items
- Non-external level-01 group items if none of their subordinate items are referenced
- Unreferenced special registers

Note: The STGOPT option is ignored for data items that have the VOLATILE clause. For details, see VOLATILE clause in the *Enterprise COBOL Language Reference*.

The compiler will not generate code to initialize discarded data items to the values in their VALUE clauses.

In addition, with STGOPT, data items in the LOCAL-STORAGE SECTION can be reordered in memory to optimize performance.

TERMINAL

Use TERMINAL to send progress and diagnostic messages to the SYSTERM ddname.

TERMINAL option syntax

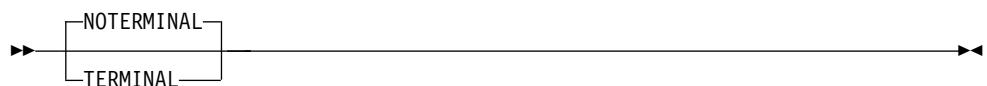

Default is: NOTERMINAL

Abbreviations are: TERM|NOTERM

Use NOTERMINAL if you do not want this additional output.

TEST

Use TEST to produce object code that enables debugging and problem determination tools such as Debug Tool and Fault Analyzer. With TEST, you can also enable the inclusion of symbolic variables in the formatted dumps that are produced by Language Environment.

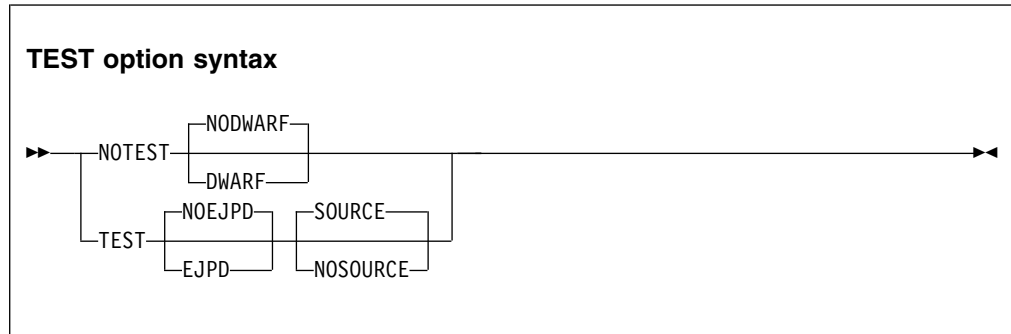

Option default is: NOTEST(NODWARF)

Suboption defaults are:

- NODWARF if only NOTEST is specified
- NOEJPD,SOURCE if only TEST is specified

Abbreviations are: None

Suboption abbreviation is: NOS | S

NOTEST suboptions

DWARF If you specify NOTEST(DWARF), basic DWARF diagnostic information is included in the application module. This option enables the best usability for application failure analysis tools, such as CEEDUMP and IBM Fault Analyzer. With NOTEST(DWARF), the debugging information is a subset of the DWARF information that is available with TEST.

Debugging information generated by the compiler is in the industry-standard DWARF format. For more information about DWARF, see *About Common Debug Architecture* in the *DWARF/ELF Extensions Library Reference*.

NODWARF

If you specify NOTEST(NODWARF), DWARF diagnostic information is not included in the application module.

TEST suboptions

When the TEST option is specified, DWARF debugging information is included in the application module.

The EJPD and NOEJPD suboptions control enablement of the Debug Tool commands JUMPTO and GOTO in production debugging sessions. These suboptions take effect only if you specify the TEST option and a non-zero OPTIMIZE level (OPTIMIZE(1) or OPTIMIZE(2)).

EJPD If you specify TEST(EJPD) and a non-zero OPTIMIZE level:

- The JUMPTO and GOTO commands are enabled.
- The amount of program optimization is reduced. Optimization is done within statements, but most optimizations do not cross statement boundaries.

NOEJPD If you specify TEST(NOEJPD) and a non-zero OPTIMIZE level:

- The JUMPTO and GOTO commands are not enabled. However, you can still use JUMPTO and GOTO if you use the SET WARNING OFF Debug Tool command. In this scenario, JUMPTO and GOTO will have unpredictable results.
- The normal amount of program optimization is done.

SOURCE If you specify TEST(SOURCE), the generated DWARF debug information generated by the compiler includes the expanded source code, and the compiler listing is not needed by IBM Debug Tool.

NOSOURCE

| If you specify TEST(NOSOURCE), the generated DWARF debugging information
| does not include the expanded source code, and you will not be able to
| use IBM Debug Tool.

Note: If you specify the TEST option, you must set the CODEPAGE option to the CCSID that is used for the COBOL source program. In particular, programs that use Japanese characters in DBCS literals or DBCS user-defined words must be compiled with the CODEPAGE option set to a Japanese codepage CCSID. For more information, see “CODEPAGE” on page 313.

Performance versus debugging capability:

You can control the amount of debugging capability that you get and so also the program performance, as follows:

- For the best performance, but with some restrictions on debugging, compile using a non-zero OPTIMIZE level, STGOPT and TEST(NOEJPD).
 - The Debug Tool commands JUMPTO and GOTO are not supported. However, you can still use JUMPTO and GOTO if you use the SET WARNING OFF Debug Tool command. In this scenario, JUMPTO and GOTO will have unpredictable results.
 - Except for the DESCRIBE ATTRIBUTES command, Debug Tool commands cannot refer to any data item that was discarded from a program by the STGOPT option.
 - The Debug Tool command AT CALL *entry-name* is not supported.
- For some reduction in program performance from the production-debugging scenario above, but to enable predictable behavior for the Debug Tool commands JUMPTO and GOTO, specify a non-zero OPTIMIZE level and TEST(EJPD).

The restrictions above about referring to items discarded by the STGOPT option, and about the AT CALL command also apply when you use a non-zero OPTIMIZE level and TEST(EJPD).

- For slowest performance but maximum debugging capability, specify OPTIMIZE(0), NOSTGOPT and TEST.

The OPTIMIZE(0) option causes the compiler to generate slower code, but all Debug Tool commands are supported.

Language Environment:

The TEST option specified with any of its suboptions can improve your formatted dumps from Language Environment by adding these two features to the dumps:

- A line number that indicates the failing statement, rather than just an offset
- The values of the program variables

With NOTEST(DWARF), the dump will have program variables but will not have the line number of the failing statement. With NOTEST(NODWARF), the dump will not have program variables nor the line number of the failing statement.

Enterprise COBOL uses the Language Environment-provided dump services to produce dumps that are consistent in content and format with those that are produced by other Language Environment-conforming member languages.

Whether Language Environment produces a dump for unhandled conditions depends on the setting of the runtime option TERMTHDACT. If you specify TERMTHDACT(DUMP), a dump is generated when a condition of severity 2 or greater goes unhandled.

RELATED CONCEPTS

DWARF/ELF Extensions Library Reference (About Common Debug Architecture)

RELATED TASKS

“Using the debugger” on page 395

Language Environment Debugging Guide (Generating a Language Environment dump with TERMTHDACT)

Debug Tool User’s Guide (Special considerations while using the TEST runtime option)

RELATED REFERENCES

“Logical record length and block size” on page 268

“cob2 input and output files” on page 288

“Conflicting compiler options” on page 304

“OPTIMIZE” on page 346

Language Environment Programming Reference (TEST | NOTEST)

THREAD

THREAD indicates that a COBOL program is to be enabled for execution in a Language Environment enclave that has multiple POSIX threads or PL/I tasks.

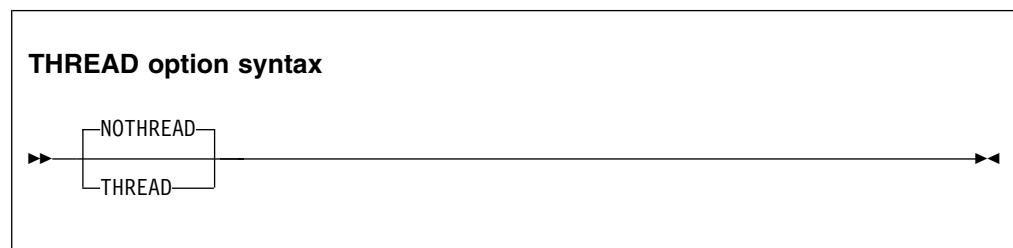

Default is: NOTHREAD

Abbreviations are: None

A program that has been compiled using the THREAD option can also be used in a nonthreaded application. However, if a COBOL program is to be run in a threaded application, all the COBOL programs in the Language Environment enclave must be compiled using the THREAD option.

NOTHREAD indicates that the COBOL program is not to be enabled for execution in an enclave that has multiple POSIX threads or PL/I tasks.

Programs that are compiled using compilers earlier than Enterprise COBOL are treated as if compiled using NOTHREAD.

If the THREAD option is in effect, the following elements are not supported. If encountered, they are diagnosed as errors:

- ALTER statement
- DEBUG-ITEM special register
- GO TO statement without procedure-name
- INITIAL phrase in PROGRAM-ID clause
- Nested programs
- RERUN
- Segmentation module
- SORT or MERGE statements
- STOP *literal* statement
- USE FOR DEBUGGING statement

Additionally, some language constructs have different semantics than in the nonthreaded case.

Although threaded applications are subject to a number of programming and environment restrictions, the use of a program in nonthreaded applications is not so restricted. For example, a program compiled using the THREAD option can run in the CICS and IMS environments, can run AMODE 24, and can call and be called by other programs that are not enabled for multithreading, provided that the application does not contain multiple POSIX threads or PL/I tasks at run time.

Programs compiled using the THREAD option are supported in the reusable environment that is created by calling the Language Environment preinitialization routine CEEPIPI. But a reusable environment created by using the RTEREUS runtime option is not supported for programs compiled using the THREAD option.

Performance consideration: If you use the THREAD option, you can expect some runtime performance degradation due to the overhead of serialization logic that is automatically generated.

RELATED TASKS

Chapter 27, “Preparing COBOL programs for multithreading,” on page 517

RELATED REFERENCES

“Conflicting compiler options” on page 304

TRUNC

TRUNC affects the way that binary data is truncated during moves and arithmetic operations.



Default is: TRUNC(STD)

Abbreviations are: None

TRUNC has no effect on COMP-5 data items; COMP-5 items are handled as if TRUNC(BIN) is in effect regardless of the TRUNC suboption specified.

TRUNC(STD)

TRUNC(STD) applies only to USAGE BINARY receiving fields in MOVE statements and arithmetic expressions. When TRUNC(STD) is in effect, the final result of an arithmetic expression, or the sending field in the MOVE statement, is truncated to the number of digits in the PICTURE clause of the BINARY receiving field.

TRUNC(OPT)

TRUNC(OPT) is a performance option. When TRUNC(OPT) is in effect, the compiler assumes that data conforms to PICTURE specifications in USAGE BINARY receiving fields in MOVE statements and arithmetic expressions. The results are manipulated in the most optimal way, either truncating to the number of digits in the PICTURE clause, or to the size of the binary field in storage (halfword, fullword, or doubleword).

Tips:

- Use the TRUNC(OPT) option only if you are sure that the data being moved into the binary areas will not have a value with larger precision than that defined by the PICTURE clause for the binary item. Otherwise, unpredictable results could occur. This truncation is performed in the most efficient manner possible; therefore, the results are dependent on the particular code sequence generated. It is not possible to predict the truncation without seeing the code sequence generated for a particular statement.

TRUNC(BIN)

The TRUNC(BIN) option applies to all COBOL language that processes USAGE BINARY data. When TRUNC(BIN) is in effect, all binary items (USAGE COMP, COMP-4, or BINARY) are handled as native hardware binary items, that is, as if they were each individually declared USAGE COMP-5:

- BINARY receiving fields are truncated only at halfword, fullword, or doubleword boundaries.
- BINARY sending fields are handled as halfwords, fullwords, or doublewords when the receiver is numeric; TRUNC(BIN) has no effect when the receiver is not numeric.

- The full binary content of fields is significant.
- DISPLAY will convert the entire content of binary fields with no truncation.

Recommendations: TRUNC(BIN) is the recommended option for programs that use binary values set by other products. Other products, such as IMS, DB2, C/C++, FORTRAN, and PL/I, might place values in COBOL binary data items that do not conform to the PICTURE clause of the data items. You can use TRUNC(OPT) with CICS programs provided that your data conforms to the PICTURE clause for your BINARY data items.

USAGE COMP-5 has the effect of applying TRUNC(BIN) behavior to individual data items. Therefore, you can avoid the performance overhead of using TRUNC(BIN) for every binary data item by specifying COMP-5 on only some of the binary data items, such as those data items that are passed to non-COBOL programs or other products and subsystems. The use of COMP-5 is not affected by the TRUNC suboption in effect.

Large literals in VALUE clauses: When you use the compiler option TRUNC(BIN), numeric literals specified in VALUE clauses for binary data items (COMP, COMP-4, or BINARY) can generally contain a value of magnitude up to the capacity of the native binary representation (2, 4, or 8 bytes) rather than being limited to the value implied by the number of 9s in the PICTURE clause.

TRUNC example 1

```
01 BIN-VAR      PIC S99 USAGE BINARY.
. . .
MOVE 123451 to BIN-VAR
```

The following table shows values of the data items after the MOVE statement.

Data item	Decimal	Hex	Display
Sender	123451	00101E213B	123451
Receiver TRUNC(STD)	51	00133	51
Receiver TRUNC(OPT)	-7621	E213B	2J
Receiver TRUNC(BIN)	-7621	E213B	762J

A halfword of storage is allocated for BIN-VAR. The result of this MOVE statement if the program is compiled with the TRUNC(STD) option is 51; the field is truncated to conform to the PICTURE clause.

If you compile the program with TRUNC(BIN), the result of the MOVE statement is -7621. The reason for the unusual result is that nonzero high-order digits are truncated. Here, the generated code sequence would merely move the lower halfword quantity X'E23B' to the receiver. Because the new truncated value overflows into the sign bit of the binary halfword, the value becomes a negative number.

It is better not to compile this MOVE statement with TRUNC(OPT), because 123451 has greater precision than the PICTURE clause for BIN-VAR. With TRUNC(OPT), the results are again -7621. This is because the best performance was obtained by not doing a decimal truncation.

TRUNC example 2

```
01 BIN-VAR      PIC 9(6)  USAGE BINARY
. . .
  MOVE 1234567891 to BIN-VAR
```

The following table shows values of the data items after the MOVE statement.

Data item	Decimal	Hex	Display
Sender	1234567891	49 96 02 D3	1234567891
Receiver TRUNC(STD)	567891	00 08 AA 53	567891
Receiver TRUNC(OPT)	567891	53 AA 08 00	567891
Receiver TRUNC(BIN)	1234567891	49 96 02 D3	1234567891

When you specify TRUNC(STD), the sending data is truncated to six integer digits to conform to the PICTURE clause of the BINARY receiver.

When you specify TRUNC(OPT), the compiler assumes the sending data is not larger than the PICTURE clause precision of the BINARY receiver. The most efficient code sequence in this case is truncation as if TRUNC(STD) were in effect.

When you specify TRUNC(BIN), no truncation occurs because all of the sending data fits into the binary fullword allocated for BIN-VAR.

RELATED CONCEPTS

“Formats for numeric data” on page 47

RELATED TASKS

“Compiling with the CICS option” on page 433

RELATED REFERENCES

“NUMCHECK” on page 341

VALUE clause (*Enterprise COBOL Language Reference*)

VBREF

Use VBREF to get a cross-reference between all verbs used in the source program and the line numbers in which they are used. VBREF also produces a summary of the number of times each verb was used in the program.

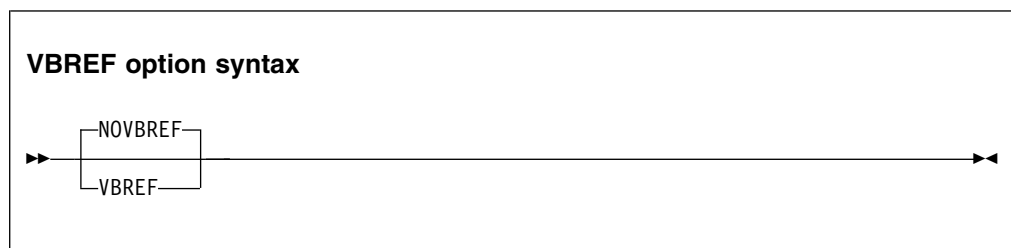

Default is: NOVBREF

Abbreviations are: None

Use NOVBREF for more efficient compilation.

VLR

The VLR option affects the file status returned from READ statements for variable-length records when the length of record returned is inconsistent with the record descriptions. It eases your migration from earlier versions to Enterprise COBOL V5, if your programs have READ statements that result in a record length conflict.

VLR option syntax



The diagram shows the VLR option syntax: `VLR([STANDARD | COMPAT])`. A horizontal line with arrowheads at both ends spans the width of the box. Above the line, the word "STANDARD" is written. Below the line, the word "COMPAT" is written. A bracket connects the two words, indicating they are alternative options for the parameter inside the parentheses.

Default is: VLR(STANDARD)

Abbreviations are: VLR(C|S)

After the execution of a READ statement:

- If the number of character positions in the record that is read is less than the minimum size specified by the record description entries for the file, the portion of the record area that is to the right of the last valid character read is undefined.
- If the number of character positions in the record that is read is greater than the maximum size specified by the record description entries for the file, the record is truncated on the right to the maximum size.

In either of these cases, the READ statement is successful, and the file status is set to either 00 (hiding the record length conflict condition) or 04 (indicating that a record length conflict has occurred), depending on the VLR compiler option setting.

VLR(COMPAT)

If you specify VLR(COMPAT), you get the status value of 00 when READ statements encounter a record length conflict.

Note: This setting can hide I/O problems that can arise with the wrong length read situation. Use the VLR(COMPAT) option with caution, and check for correct READ statements.

VLR(STANDARD)

If you specify VLR(STANDARD), you get the status value of 04 when READ statements encounter a record length conflict.

You can add code to test for FS=04 to avoid accessing undefined data in a record and also avoid getting protection exceptions for attempting to reference a part of the record that was truncated.

Using VLR(STANDARD) can result in more reliable code and fewer I/O problems because the file status will tell you when a “wrong length READ” might occur. A new compiler message, MSGIGYP3178, can also help you avoid I/O problems by

telling you if a program has a possibility of a “wrong length READ”. This message can be used to assist with migration from VLR(COMPAT) to VLR(STANDARD) by indicating the possible “wrong length READ” that you can solve by correcting the File Definition (FD). You can also raise the severity of the message so that the program must be corrected in order to run. To do this, use the MSGEXIT suboption of the EXIT compiler option to change the severity of message MSGIGYP3178 from I (RC=0) to S (RC=12), E (RC=8), or W (RC=4). If you are not interested in seeing this message, you can suppress the message completely.

RELATED REFERENCES

“EXIT” on page 324

Compatible READ results of variable length records - wrong length READ
(*Enterprise COBOL Migration Guide*)

VSAMOPENFS

The VSAMOPENFS option affects the user file status reported from successful VSAM OPEN statements that require verified file integrity check.

VSAMOPENFS option syntax

Diagram illustrating the VSAMOPENFS option syntax: `VSAMOPENFS (COMPAT | SUCC)`. The diagram shows the option name followed by a choice between COMPAT and SUCC, enclosed in parentheses. Arrows indicate the start and end of the option.

Default is: VSAMOPENFS(COMPAT)

Abbreviations are: VS(C | S)

COMPAT If you specify VSAMOPENFS(COMPAT), the statement returns the file status 97 when a VSAM OPEN statement is successfully verified. This is compatible with pre-V6 COBOL runtime behavior.

SUCC If you specify VSAMOPENFS(SUCC), the statement returns the file status 00 when a VSAM OPEN statement is successfully verified. This allows users to simply check for 0 in the first digit of the returned file status, as they usually do with other successful operations.

WORD

Use WORD(xxxx) to specify that an alternate reserved-word table is to be used during compilation.

WORD option syntax

Diagram illustrating the WORD option syntax: `WORD (NOWORD | WORD (xxxx))`. The diagram shows the option name followed by a choice between NOWORD and WORD(xxxx), enclosed in parentheses. Arrows indicate the start and end of the option.

Default is: NOWORD

Abbreviations are: WD|NOWD

xxxx specifies the ending characters of the name of the reserved-word table (IGYC*xxxx*) to be used in your compilation. IGYC are the first four standard characters of the name, and *xxxx* can be one to four characters in length.

Alternate reserved-word tables provide changes to the IBM-supplied default reserved-word table. Your systems programmer might have created one or more alternate reserved-word tables for your site. See your systems programmer for the names of alternate reserved-word tables.

Enterprise COBOL provides an alternate reserved-word table (IGYCCICS) specifically for CICS applications. It is set up to flag COBOL words not supported under CICS with an error message. If you want to use this CICS reserved-word table during your compilation, specify the compiler option WORD(CICS).

RELATED TASKS

“Compiling with the CICS option” on page 433

RELATED REFERENCES

“Conflicting compiler options” on page 304

“CICS reserved-word table” on page 437

XMLPARSE

Use XMLPARSE to select the parser to be used for processing XML input, and, therefore, the XML processing capabilities that are available to your program.

XMLPARSE option syntax

The diagram shows the syntax for the XMLPARSE option. It consists of the word XMLPARSE followed by an opening parenthesis. Inside the parenthesis, there are two options: XMLSS and COMPAT, each enclosed in a small rectangular box. A vertical line connects the top of the XMLSS box to the top of the COMPAT box, indicating that either option can be used. The parenthesis is closed with a closing parenthesis. The entire syntax is enclosed in a larger rectangular box with arrows at the ends.

Default is: XMLSS

Abbreviations are: XP(X|C)

If you specify the XMLPARSE(XMLSS) option, XML PARSE statements are processed using the z/OS XML System Services parser. The following XML parsing capabilities are available only if you specify XMLPARSE(XMLSS):

- Validation of XML input documents against an XML schema (by using the VALIDATING phrase of the XML PARSE statement)
- Enhanced namespace processing (special registers XML-NAMESPACE, XML-NNAMESPACE, XML-NAMESPACE-PREFIX, and XML-NNAMESPACE-PREFIX)
- Automatic conversion of document fragments to Unicode UTF-16 (by using the RETURNING NATIONAL phrase of the XML PARSE statement)
- Specification of the encoding of the input document (by using the ENCODING phrase of the XML PARSE statement)

- Direct parsing of XML documents encoded in UTF-8
- Parsing of XML documents, a buffer of XML at a time
- Offloading of XML parsing to System z Application Assist Processors (zAAPs)

If you specify the XMLPARSE(COMPAT) option, XML PARSE statements are processed using the XML parser that is a built-in component of the COBOL library. The XML PARSE statement results and operational behaviors are then compatible with those obtained with Enterprise COBOL Version 3, and also with Version 4 when XMLPARSE(COMPAT) was used, and the advanced features described above for XMLPARSE(XMLSS) are not available.

RELATED TASKS

Chapter 28, “Processing XML input,” on page 527

RELATED REFERENCES

XML PARSE statement (*Enterprise COBOL Language Reference*)
 z/OS XML System Services User’s Guide and Reference

XREF

Use XREF to produce a sorted cross-reference listing.

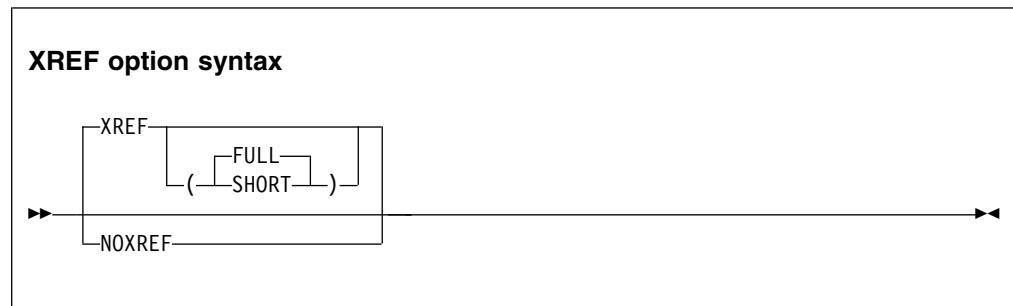

Default is: XREF(FULL)

Abbreviations are: X|NOX

You can choose XREF, XREF(FULL), or XREF(SHORT). If you specify XREF without any suboptions, XREF(FULL) will be in effect.

A section of the listing shows all the program-names, data-names, and procedure-names that are referenced in your program, and the line numbers where those names are defined. External program-names are identified.

“Example: XREF output: data-name cross-references” on page 421

“Example: XREF output: program-name cross-references” on page 422

A section is also included that cross-references COPY or BASIS statements in the program with the data sets or files from which associated copybooks were obtained.

“Example: XREF output: COPY/BASIS cross-references” on page 422

EBCDIC data-names and procedure-names are listed in alphanumeric order. DBCS data-names and procedure-names are listed based on their physical order in the program; they are shown before the EBCDIC data-names and procedure-names unless the DBCSXREF installation option is selected with a DBCS ordering program. In that case, DBCS data-names and procedure-names are in the order specified by the DBCS ordering program.

If you use XREF and SOURCE, data-name and procedure-name cross-reference information is printed on the same line as the original source. Line-number references or other information appears on the right-hand side of the listing page. On the right of source lines that reference an intrinsic function, the letters IFN are printed with the line number of the locations where the function arguments are defined. Information included in the embedded references lets you know if an identifier is undefined (UND) or defined more than once (DUP), if items are implicitly defined (IMP) (such as special registers or figurative constants), or if a program-name is external (EXT).

If you use XREF and NOSOURCE, you get only the sorted cross-reference listing.

XREF(SHORT) prints only the explicitly referenced data items in the cross-reference listing. XREF(SHORT) applies to DBCS data-names and procedure-names as well as to single-byte names.

NOXREF suppresses this listing.

Usage notes

- Group names used in a MOVE CORRESPONDING statement are in the XREF listing. The elementary names in those groups are also listed.
- In the data-name XREF listing, line numbers that are preceded by the letter M indicate that the data item is explicitly modified by a statement on that line.
- XREF listings take additional storage.
- If there is more than one data set in your SYSLIB concatenation, in some cases the COPY/BASIS cross-reference might be incomplete or missing. This loss can occur if XREF is set only in a CBL or PROCESS statement, and XREFOPT=NO is set as an installation default or NOXREF is coded in your JCL PARM parameter.
To ensure that the COPY/BASIS cross-reference is complete, either verify with your system programmer that XREFOPT=FULL or XREFOPT=SHORT is your installation default, or code the XREF option in your JCL PARM parameter.

RELATED CONCEPTS

Chapter 19, “Debugging,” on page 385

RELATED TASKS

“Getting listings” on page 395

RELATED REFERENCES

Language Environment Debugging Guide (COBOL compiler options)

ZONECHECK

Use the ZONECHECK option to have the compiler generate IF NUMERIC class tests for every use of zoned decimal data items.

Note: In Enterprise COBOL V5.2 with PTF for APAR PI81006 installed, ZONECHECK is deprecated but is tolerated for compatibility, and it is replaced by NUMCHECK(ZON(ALPHNUM)).

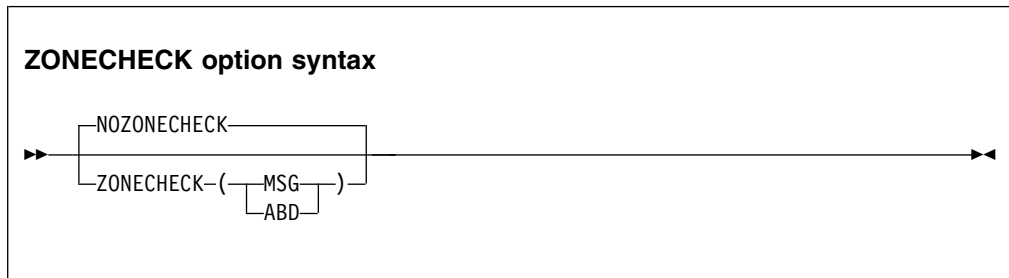

Default is: NOZONECHECK

Abbreviations are: NOZC | ZC(MSG) | ZC(ABD)

MSG

The MSG suboption requests that an IF NUMERIC test be done on every use of zoned decimal data items as senders, and if the data is invalid (for example, NOT NUMERIC), a runtime warning message with the line number and data item name is issued. ZONECHECK(MSG) is treated as if NUMCHECK(ZON,MSG) were in effect.

ABD

The ABD suboption requests that an IF NUMERIC test be done on every use of zoned decimal data items as senders, and if the data is invalid (for example, NOT NUMERIC), a terminating message is issued that causes an abend. ZONECHECK(ABD) is treated as if NUMCHECK(ZON,ABD) were in effect.

Both ZONECHECK(MSG) and ZONECHECK(ABD) result in the compiler generating an implicit numeric class test for each zoned decimal data item that is referenced as a sender in a COBOL statement. Receivers are not checked, unless they are both a sender and a receiver, such as data item B in the following sample statements:

```
ADD A TO B
DIVIDE A INTO B
COMPUTE B = A + B
INITIALIZE B REPLACING ALPHANUMERIC BY B
```

This checking is done before the data item is used in each statement:

- If the data item is NOT NUMERIC, either a warning message for ZONECHECK(MSG) or a terminating message for ZONECHECK(ABD) is issued.
- If the data item is NUMERIC, the external behavior of the statement is the same as NOZONECHECK, other than being slower.

Performance considerations: ZONECHECK(MSG) and ZONECHECK(ABD) are much slower than NOZONECHECK, depending on how many zoned decimal data items are used in COBOL statements in a program.

RELATED TASKS

“Checking for incompatible data (numeric class test)” on page 54

RELATED REFERENCES

"NUMCHECK" on page 341

"NUMPROC" on page 343

"ZONEDATA"

ZONEDATA

The ZONEDATA option tells the compiler whether the data in USAGE DISPLAY and PACKED-DECIMAL data items is valid, and if not, what the behavior of the compiler should be.

ZONEDATA option syntax



Default is: ZONEDATA(PFD)

Abbreviations are: ZD(PFD) | ZD(MIG) | ZD(NOPFD)

Each digit of a valid zoned decimal number is represented by a single byte from X'F0' through X'F9'. The 4 high-order bits of each byte are zone bits, and the 4 low-order bits of each byte contain the value of the digit. The 4 high-order bits of the low-order byte for SIGN TRAILING represent the sign of the item. The sign is in the high-order byte with SIGN LEADING, or in a separate byte for SIGN IS SEPARATE.

ZONEDATA(PFD)

When the ZONEDATA(PFD) option is in effect, the compiler assumes that all data in USAGE DISPLAY and PACKED-DECIMAL data items is valid, and generates the most efficient code possible to make numeric comparisons. For example, the compiler might generate a string comparison to avoid numeric conversion.

ZONEDATA(MIG)

When the ZONEDATA(MIG) option is in effect, the compiler generates instructions to do numeric comparisons that ignore the zone bits of each digit in zoned decimal data items. For example, the zoned decimal value is converted to packed-decimal with a PACK instruction before the comparison. The compiler will also avoid performing known optimizations that might produce a different result than COBOL V4 (or earlier versions) when a zoned decimal or packed decimal data item has invalid digits or an invalid sign code, or when a zoned decimal data item has invalid zone bits.

ZONEDATA(NOPFD)

When the ZONEDATA(NOPFD) option is in effect, the compiler generates instructions for numeric comparisons or an alphanumeric comparison of zoned decimal data in the same manner as COBOL V4 (or earlier versions) does when using NUMPROC(NOPFD | PFD) with COBOL V4 (or earlier versions) :

- In the cases where COBOL V4 (or earlier versions) considered the zone bits, the compiler generates an alphanumeric comparison which will also consider the zone bits of each digit in zoned decimal data items. The zoned decimal value remains as zoned decimal.
- In the cases where COBOL V4 (or earlier versions) ignored the zone bits, the compiler generates numeric comparisons that ignore the zone bits of each digit in zoned decimal data items. The zoned decimal value is converted to packed-decimal with a PACK instruction before the comparison.

In order for the compiler to generate comparisons of zoned decimal data in the same way that COBOL V4 (or earlier versions) did, the NUMPROC suboption used in COBOL V5 must match the NUMPROC suboption used in COBOL V4 (or earlier versions):

- To get the COBOL V4 (or earlier versions) NUMPROC(NOPFD) behavior in COBOL V5, use ZONEDATA(NOPFD) and NUMPROC(NOPFD) in COBOL V5.
- To get the COBOL V4 (or earlier versions) NUMPROC(PFD) behavior in COBOL V5, use ZONEDATA(NOPFD) and NUMPROC(PFD) in COBOL V5.

The compiler will also avoid performing known optimizations that might produce a different result than COBOL V4 (or earlier versions) when a zoned decimal or packed decimal data item has invalid digits or an invalid sign code, or when a zoned decimal data item has invalid zone bits.

Note: The sign code must be a valid sign code according to the NUMPROC compiler option setting. In addition, the low-order byte must have a valid zone (x'F') for unsigned and signed with either SIGN IS LEADING or SIGN IS SEPARATE.

Note: The ZONEDATA option affects the behaviour of MOVE statements, comparisons, and computations for USAGE DISPLAY or PACKED-DECIMAL data items that could contain invalid digits, an invalid sign code, or invalid zone bits.

In the following example, you can see a data item with an invalid zone bit 4 in the zone bits in the middle of data item VALUE1, forced in by REDEFINES:

```

77 VALUE0    PIC X(4) VALUE '00 0'.          < *  x'F0F040F0'
77 VALUE1    REDEFINES VALUE0 PIC 9(4).
PROCEDURE DIVISION.
  IF VALUE1 = ZERO
    DISPLAY 'ZONEDATA(MIG) is in effect ' VALUE1
  ELSE
    DISPLAY 'ZONEDATA(NOPFD | PFD) is in effect ' VALUE1
  END-IF

```

In this example:

- With COBOL V4 (or earlier versions) or earlier versions, the test is true if the NUMPROC(MIG) option is used, and false for NUMPROC(NOPFD | PFD).
- With COBOL V5 or later versions:
 - When using ZONEDATA(PFD), the test is true at OPT(0) and false at OPT(1 | 2).
 - When using ZONEDATA(NOPFD), the test is false at any OPT setting.

In all, to ease your migration to COBOL V5:

- If your digits, sign code, and zone bits are valid, use ZONEDATA(PFD) and the same NUMPROC setting that you used with COBOL V4 (or earlier versions) when using COBOL V5.
- If you have invalid digits, invalid sign code, or invalid zone bits:

- If you used NUMPROC(MIG) with COBOL V4 (or earlier versions) , use ZONEDATA(MIG) and NUMPROC(NOPFD) with COBOL V5.
- If you used NUMPROC(NOPFD) with COBOL V4 (or earlier versions) , use ZONEDATA(NOPFD) and NUMPROC(NOPFD) with COBOL V5.
- If you used NUMPROC(PFD) with COBOL V4 (or earlier versions) , use ZONEDATA(NOPFD) and NUMPROC(PFD) with COBOL V5.

Note: It is not always possible to entirely match the behaviour of the old compiler even with these options when faced with clearly invalid data. For example, even for compares, ZONEDATA(NOPFD) isn't going to give the same result in all cases as COBOL V4.

Performance considerations: ZONEDATA(PFD) gives better runtime performance than ZONEDATA(NOPFD | MIG) does. ZONEDATA(NOPFD | MIG) disables some of the optimizations that NUMPROC(PFD) can give.

RELATED TASKS

“Checking for incompatible data (numeric class test)” on page 54

RELATED REFERENCES

- “NUMCHECK” on page 341
- “NUMPROC” on page 343
- “ZONECHECK” on page 375

ZWB

If you compile using ZWB, the compiler removes the sign from a signed zoned decimal (DISPLAY) field before comparing this field to an alphanumeric elementary field during execution.

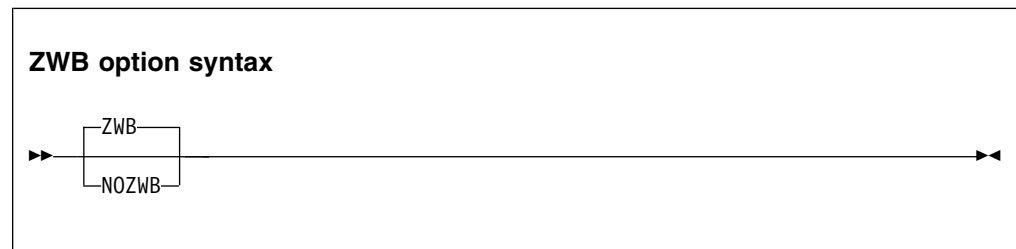

Default is: ZWB

Abbreviations are: None

If the zoned decimal item is a scaled item (that is, it contains the symbol P in its PICTURE string), comparisons that use the decimal item are not affected by ZWB. Such items always have their sign removed before the comparison is made to an alphanumeric field.

ZWB affects how a program runs. The same COBOL program can produce different results depending on the setting of this option.

Use NOZWB if you want to test input numeric fields for SPACES.

Chapter 18. Compiler-directing statements

Several statements help you to direct the compilation of your program.

These are the compiler-directing statements:

BASIS statement

This extended source program library statement provides a complete COBOL program as the source for a compilation. For rules of formation and processing, see the description of *text-name* for the COPY statement.

CALLINTERFACE directive

The CALLINTERFACE directive specifies the interface convention for CALL and SET statements. The convention specified stays in effect until another CALLINTERFACE directive is encountered in the source.

The CALLINTERFACE directive can be used only in the procedure division and its effect is limited to the current compilation unit.

***CONTROL (*CBL)** statement

This compiler-directing statement selectively suppresses or allows output to be produced. The names *CONTROL and *CBL are synonymous.

COPY statement

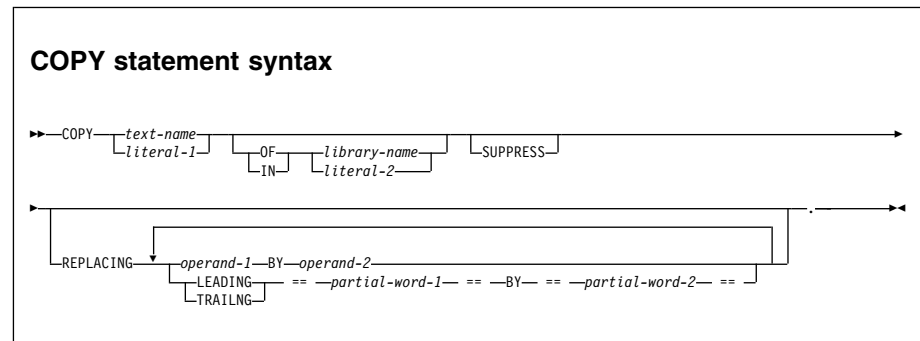

This library statement places prewritten text into a COBOL program.

Neither *text-name* nor *library-name* need to be unique within a program. They can be identical to other user-defined words in the program, except that they cannot contain the underscore.

The uniqueness of *text-name* and *library-name* is determined after the formation and conversion rules for a system-dependent name have been applied. If *library-name* is omitted, SYSLIB is assumed.

Compiling with JCL:

text-name, *library-name*, and *literal-1* and *literal-2* are processed as follows:

- The name (which can be from one to 30 characters long) is truncated to eight characters. Only the first eight characters of *text-name* and *library-name* are used as the identifying name. These eight characters must be unique within any COBOL library.
- The name is folded to uppercase.
- Hyphens that are not the first or last character are translated to zero (0), and a warning message is issued.

- If the first character is numeric, then the characters 1-9 are translated to A-I, zero (0) is converted to J, and a warning message is issued.

For example:

```
COPY INVOICES1Q
COPY "Company-#Employees" IN Personellib
```

In the IN/OF phrase, *library-name* is the ddname that identifies the partitioned data set to be copied from. Use a DD statement such as in the following example to define *library-name*:

```
//COPYLIB DD DSN=ABC.COB,VOLUME=SER=111111,
//          DISP=SHR,UNIT=3380
```

To specify more than one copy library, use either JCL or a combination of JCL and the IN/OF phrase. Using just JCL, concatenate data sets in your DD statement for SYSLIB. Alternatively, define multiple DD statements and include the IN/OF phrase in your COPY statements.

The maximum block size for the copy library depends on the device on which your data set resides.

Compiling in the z/OS UNIX shell:

When you compile using the cob2 command, copybooks are included from the z/OS UNIX file system. *text-name*, *library-name*, and *literal-1* and *literal-2* are processed as follows:

- User-defined words are folded to uppercase. Literals are not folded. Because UNIX is case sensitive, if your file-name is lowercase or mixed case, you must specify it as a literal.
- If *text-name* is a literal and *library-name* is omitted, *text-name* is used directly: as a file-name, a relative path name, or an absolute path name (if the first character is /). For example:

```
COPY "MyInc"
COPY "x/MyInc"
COPY "/u/user1/MyInc"
```

- If *text-name* is a user-defined word, and an environment variable of that name is defined, the value of the environment variable is used as the name of the file that contains the copybook.

If an environment variable of that name is not defined, the copybook is searched for under the following names, in this order:

1. *text-name.cpy*
2. *text-name.CPY*
3. *text-name.cbl*
4. *text-name.CBL*
5. *text-name.cob*
6. *text-name.COB*
7. *text-name*

- If *library-name* is a literal, it is treated as the actual path, relative or absolute, from which to copy file *text-name*.
- If *library-name* is a user-defined word, it is treated as an environment variable. The value of the environment variable is used as the path. If the environment variable is not set, an error occurs.
- If both *library-name* and *text-name* are specified, the compiler forms the path name for the copybook by concatenating *library-name* and *text-name*

with a path separator (/) inserted between the two values. For example, suppose you have the following setting for COPY MYCOPY OF MYLIB:

```
export MYCOPY=mystuff/today.cpy
export MYLIB=/u/user1
```

These settings result in:

```
/u/user1/mystuff/today.cpy
```

If *library-name* is an environment variable that identifies the path from which copybooks are to be copied, use an export command to define *library-name*, as in this example:

```
export COPYLIB=/u/mystuff/copybooks
```

The name of the environment variable must be uppercase. To specify more than one copy library, set the environment variable to multiple path names delimited by colon (:).

If *library-name* is omitted and *text-name* is not an absolute path name, the copybook is searched for in this order:

1. In the current directory
2. In the paths specified on the -I cob2 option
3. In the paths specified in the SYSLIB environment variable

For additional information about the COPY statement, for example, the rules for text replacement, see the related reference.

DELETE statement

This extended source library statement removes COBOL statements from the BASIS source program.

EJECT statement

This compiler-directing statement specifies that the next source statement is to be printed at the top of the next page.

ENTER statement

The statement is treated as a comment.

INSERT statement

This library statement adds COBOL statements to the BASIS source program.

PROCESS (CBL) statement

This statement, which you place before the IDENTIFICATION DIVISION header of an outermost program, indicates which compiler options are to be used during compilation of the program.

REPLACE statement

This statement is used to replace source program text.

SERVICE LABEL statement

This statement is generated by the CICS translator to indicate control flow, and should be used at the resume point for a call to CEE3SRP. It is not intended for general use.

SKIP1/2/3 statement

These statements indicate lines to be skipped in the source listing.

TITLE statement

This statement specifies that a title (header) should be printed at the top of each page of the source listing.

USE statement

The USE statement provides *declaratives* to specify these elements:

- Error-handling procedures: EXCEPTION/ERROR
- Debugging lines and sections: DEBUGGING

RELATED TASKS

“Changing the header of a source listing” on page 5

“Specifying compiler options under z/OS” on page 272

“Specifying compiler options under z/OS UNIX” on page 284

“Setting environment variables under z/OS UNIX” on page 283

“Eliminating repetitive coding” on page 675

RELATED REFERENCES

“cob2 syntax and options” on page 287

CALLINTERFACE (*Enterprise COBOL Language Reference*)

COPY statement (*Enterprise COBOL Language Reference*)

Chapter 19. Debugging

You can choose between two different approaches to determine the cause of problems in the behavior of your application: source-language debugging or interactive debugging.

For source-language debugging, COBOL provides several language elements, compiler options, and listing outputs that make debugging easier.

If the problem with your program is not easily detected and you do not have a debugger available, you might need to analyze a storage dump of your program.

For interactive debugging, you can use Debug Tool. Debug Tool offers these productivity enhancements:

- Interactive debugging (in full-screen or line mode), or debugging in batch mode
During an interactive full-screen mode session, you can use Debug Tool's full-screen services and session panel windows on a 3270 device to debug your program while it is running.
- COBOL-like commands
For each high-level language supported, commands for coding actions to be taken at breakpoints are provided in a syntax similar to that programming language.
- Mixed-language debugging
You can debug an application that contains programs written in a different language. Debug Tool automatically determines the language of the program or subprogram being run.
- COBOL-CICS debugging
Debug Tool supports the debugging of CICS applications in both interactive and batch mode.
- Support for remote debugging
Workstation users can use the IBM Debug Tool Plug-in for Eclipse or the IBM Problem Determination Tools with Rational® Developer for System z for debugging programs that run on z/OS.

RELATED TASKS

"Debugging with source language"
"Debugging using compiler options" on page 390
"Using the debugger" on page 395
"Getting listings" on page 395
Debug Tool User's Guide

RELATED REFERENCES

Debug Tool Reference and Messages
Language Environment Debugging Guide (Formatting and analyzing system dumps, Debugging example COBOL programs)

Debugging with source language

You can use several COBOL language features to pinpoint the cause of a failure in a program.

If a failing program is part of a large application that is already in production (precluding source updates), write a small test case to simulate the failing part of the program. Code debugging features in the test case to help detect these problems:

- Errors in program logic
- Input-output errors
- Mismatches of data types
- Uninitialized data
- Problems with procedures

RELATED TASKS

“Tracing program logic”

“Finding and handling input-output errors” on page 387

“Validating data” on page 387

“Moving, initializing or setting uninitialized data” on page 388

“Generating information about procedures” on page 388

RELATED REFERENCES

Source language debugging (*Enterprise COBOL Language Reference*)

Tracing program logic

Trace the logic of your program by adding DISPLAY statements.

For example, if you determine that the problem is in an EVALUATE statement or in a set of nested IF statements, use DISPLAY statements in each path to see the logic flow. If you determine that the calculation of a numeric value is causing the problem, use DISPLAY statements to check the value of some interim results.

If you use explicit scope terminators to end statements in your program, the logic is more apparent and therefore easier to trace.

To determine whether a particular routine started and finished, you might insert code like this into your program:

```
DISPLAY "ENTER CHECK PROCEDURE"  
    .  
    . (checking procedure routine)  
    .  
DISPLAY "FINISHED CHECK PROCEDURE"
```

After you are sure that the routine works correctly, disable the DISPLAY statements in one of two ways:

- Put an asterisk in column 7 of each DISPLAY statement line to convert it to a comment line.
- Put a D in column 7 of each DISPLAY statement to convert it to a comment line. When you want to reactivate these statements, include a WITH DEBUGGING MODE clause in the ENVIRONMENT DIVISION; the D in column 7 is ignored and the DISPLAY statements are implemented.

Before you put the program into production, delete or disable the debugging aids you used and recompile the program. The program will run more efficiently and use less storage.

RELATED CONCEPTS

“Scope terminators” on page 20

RELATED REFERENCES

DISPLAY statement (*Enterprise COBOL Language Reference*)

Finding and handling input-output errors

File status keys can help you determine whether your program errors are due to input-output errors occurring on the storage media.

To use file status keys in debugging, check for a nonzero value in the status key after each input-output statement. If the value is nonzero (as reported in an error message), look at the coding of the input-output procedures in the program. You can also include procedures to correct the error based on the value of the status key.

If you determine that a problem lies in an input-output procedure, include the USE EXCEPTION/ERROR declarative to help debug the problem. Then, when a file fails to open, the appropriate EXCEPTION/ERROR declarative is performed. The appropriate declarative might be a specific one for the file or one provided for the open attributes INPUT, OUTPUT, I-O, or EXTEND.

Code each USE AFTER STANDARD ERROR statement in a section that follows the DECLARATIVES keyword in the PROCEDURE DIVISION.

RELATED TASKS

“Coding ERROR declaratives” on page 244

“Using file status keys” on page 245

RELATED REFERENCES

File status key (*Enterprise COBOL Language Reference*)

Validating data

If you suspect that your program is trying to perform arithmetic on nonnumeric data or is receiving the wrong type of data on an input record, use the class test (the class condition) to validate the type of data.

You can use the class test to check whether the content of a data item is ALPHABETIC, ALPHABETIC-LOWER, ALPHABETIC-UPPER, DBCS, KANJI, or NUMERIC. If the data item is described implicitly or explicitly as USAGE NATIONAL, the class test checks the national character representation of the characters associated with the specified character class.

You can use the UVALID intrinsic function to check whether a national data item contains valid UTF-16 encoded data, or whether an alphanumeric or alphabetic item contains valid UTF-8 encoded data.

RELATED TASKS

“Coding conditional expressions” on page 98

“Testing for valid DBCS characters” on page 151

RELATED REFERENCES

Class condition (*Enterprise COBOL Language Reference*)

UVALID (*Enterprise COBOL Language Reference*)

Moving, initializing or setting uninitialized data

Use an INITIALIZE or SET statement to initialize a table or data item when you suspect that a problem might be caused by residual data in those fields.

If the problem happens intermittently and not always with the same data, it could be that a switch was not initialized but is generally set to the right value (0 or 1) by chance. By using a SET statement to ensure that the switch is initialized, you can determine that the uninitialized switch is the cause of the problem or remove it as a possible cause.

RELATED REFERENCES

INITIALIZE statement (*Enterprise COBOL Language Reference*)

SET statement (*Enterprise COBOL Language Reference*)

"INITCHECK" on page 331

Generating information about procedures

Generate information about your program or test case and how it is running by coding the USE FOR DEBUGGING declarative. This declarative lets you include statements in the program and indicate when they should be performed when you run your program.

For example, to determine how many times a procedure is run, you could include a debugging procedure in the USE FOR DEBUGGING declarative and use a counter to keep track of the number of times that control passes to that procedure. You can use the counter technique to check items such as these:

- How many times a PERFORM statement runs, and thus whether a particular routine is being used and whether the control structure is correct
- How many times a loop runs, and thus whether the loop is executing and whether the number for the loop is accurate

You can use debugging lines or debugging statements or both in your program.

Debugging lines are statements that are identified by a D in column 7. To make debugging lines in your program active, code the WITH DEBUGGING MODE clause on the SOURCE-COMPUTER line in the ENVIRONMENT DIVISION. Otherwise debugging lines are treated as comments.

Debugging statements are the statements that are coded in the DECLARATIVES section of the PROCEDURE DIVISION. Code each USE FOR DEBUGGING declarative in a separate section. Code the debugging statements as follows:

- Only in a DECLARATIVES section.
- Following the header USE FOR DEBUGGING.
- Only in the outermost program; they are not valid in nested programs.
Debugging statements are also never triggered by procedures that are contained in nested programs.

To use debugging statements in your program, you must include the WITH DEBUGGING MODE clause and use the DEBUG runtime option.

Options restrictions:

- You cannot use the USE FOR DEBUGGING declarative in a program that you compile with the THREAD option.

“Example: USE FOR DEBUGGING”

RELATED REFERENCES

SOURCE-COMPUTER paragraph (*Enterprise COBOL Language Reference*)
Debugging lines (*Enterprise COBOL Language Reference*)
Debugging sections (*Enterprise COBOL Language Reference*)
DEBUGGING declarative (*Enterprise COBOL Language Reference*)

Example: USE FOR DEBUGGING

This example shows the kind of statements that are needed to use a DISPLAY statement and a USE FOR DEBUGGING declarative to test a program.

The DISPLAY statement writes information to the terminal or to an output data set. The USE FOR DEBUGGING declarative is used with a counter to show how many times a routine runs.

```
Environment Division.  
. . .  
Data Division.  
. . .  
Working-Storage Section.  
. . . (other entries your program needs)  
01 Trace-Msg    PIC X(30) Value " Trace for Procedure-Name : ".  
01 Total       PIC 9(9) Value 1.  
. . .  
Procedure Division.  
Declaratives.  
Debug-Declaratives Section.  
    Use For Debugging On Some-Routine.  
Debug-Declaratives-Paragraph.  
    Display Trace-Msg, Debug-Name, Total.  
End Declaratives.  
  
Main-Program Section.  
    . . . (source program statements)  
    Perform Some-Routine.  
    . . . (source program statements)  
    Stop Run.  
Some-Routine.  
    . . . (whatever statements you need in this paragraph)  
    Add 1 To Total.  
Some-Routine-End.
```

The DISPLAY statement in the DECLARATIVES SECTION issues this message every time the procedure Some-Routine runs:

```
Trace For Procedure-Name : Some-Routine 22
```

The number at the end of the message, 22, is the value accumulated in the data item Total; it indicates the number of times Some-Routine has run. The statements in the debugging declarative are performed before the named procedure runs.

You can also use the DISPLAY statement to trace program execution and show the flow through the program. You do this by dropping Total from the DISPLAY statement and changing the USE FOR DEBUGGING declarative in the DECLARATIVES SECTION to:

```
USE FOR DEBUGGING ON ALL PROCEDURES.
```

As a result, a message is displayed before each nondebugging procedure in the outermost program runs.

Debugging using compiler options

You can use certain compiler options to help you find errors in your program, find various elements in your program, obtain listings, and prepare your program for debugging.

You can find the following errors by using compiler options (the options are shown in parentheses):

- Syntax errors such as duplicate data-names (NOCOMPILE)
- Missing sections (SEQUENCE)
- Invalid subscript values (SSRANGE)

You can find the following elements in your program by using compiler options:

- Error messages and locations of the associated errors (FLAG)
- Program entity definitions and references; text-names and library-names from COPY or BASIS statements, and the associated data sets or files from which copybooks are obtained (XREF)
- Data items in the DATA DIVISION (MAP)
- Verb references (VBREF)

You can get a copy of your source (SOURCE) or a listing of generated code (LIST).

You prepare your program for debugging by using the TEST compiler option.

RELATED TASKS

“Finding coding errors”

“Finding line sequence problems” on page 391

“Checking for valid ranges” on page 391

“Selecting the level of error to be diagnosed” on page 392

“Finding program entity definitions and references” on page 394

“Listing data items” on page 394

“Getting listings” on page 395

RELATED REFERENCES

Chapter 17, “Compiler options,” on page 301

Finding coding errors

Use the NOCOMPILE option to compile conditionally or to only check syntax. When used with the SOURCE option, NOCOMPILE produces a listing that will help you find coding mistakes such as missing definitions, improperly defined data items, and duplicate data-names.

If you are compiling in the TSO foreground, you can send the messages to your screen by using the TERM compiler option and defining your data set as the SYSTERM data set.

Checking syntax only: To only check the syntax of your program, and not produce object code, use NOCOMPILE without a suboption. If you also specify the SOURCE option, the compiler produces a listing.

When you specify NOCOMPILE, several compiler options are suppressed. See the related reference below about the COMPILE option for details.

Compiling conditionally: To compile conditionally, use `NOCOMPILE(x)`, where x is one of the severity levels of errors. Your program is compiled if all the errors are of a lower severity than x . The severity levels that you can use, from highest to lowest, are S (severe), E (error), and W (warning).

If an error of level x or higher occurs, the compilation stops and your program is only checked for syntax.

RELATED REFERENCES

“COMPILE” on page 316

Finding line sequence problems

Use the `SEQUENCE` compiler option to find statements that are out of sequence. Breaks in sequence indicate that a section of a source program was moved or deleted.

When you use `SEQUENCE`, the compiler checks the source statement numbers to determine whether they are in ascending sequence. Two asterisks are placed beside statement numbers that are out of sequence. The total number of these statements is printed as the first line in the diagnostics after the source listing.

RELATED REFERENCES

“SEQUENCE” on page 356

Checking for valid ranges

Use the `SSRANGE` compiler option to check whether addresses fall within proper ranges.

`SSRANGE` causes the following addresses to be checked:

- Subscripted or indexed data references: Is the effective address of the specified table element within the maximum boundary of the containing group? (This checking is not done for `UNBOUNDED` tables and groups.)
- Variable-length data references (a reference to a data item that contains an `OCCURS DEPENDING ON` clause): Is the actual length greater than or equal to zero, and within the maximum defined length for the group data item? (This checking is not done for `UNBOUNDED` groups.)
- Reference-modified data references: Are the offset and length positive? Is the sum of the offset and length within the maximum length for the data item?

If the `SSRANGE` option is in effect, checking is performed at run time if the COBOL statement that contains the indexed, subscripted, variable-length, or reference-modified data item is executed.

If an effective address is outside the range of the data item that contains the referenced data, an error message is generated and the program stops. The message identifies the table or identifier that was referenced and the line number where the error occurred. Additional information is provided depending on the type of reference that caused the error.

If all subscripts, indices, and reference modifiers in a given data reference are literals and they result in a reference outside the data item, the error is diagnosed at compile time regardless of the setting of the `SSRANGE` option.

Performance consideration: SSRANGE can somewhat degrade performance because of the extra overhead to check each subscripted or indexed item.

RELATED REFERENCES

“SSRANGE” on page 361

“Performance-related compiler options” on page 669

Selecting the level of error to be diagnosed

Use the FLAG compiler option to specify the level of error to be diagnosed during compilation and to indicate whether error messages are to be embedded in the listing. Use FLAG(I) or FLAG(I,I) to be notified of all errors.

Specify as the first parameter the lowest severity level of the syntax-error messages to be issued. Optionally specify the second parameter as the lowest level of the syntax-error messages to be embedded in the source listing. This severity level must be the same or higher than the level for the first parameter. If you specify both parameters, you must also specify the SOURCE compiler option.

Table 49. Severity levels of compiler messages

Severity level	Resulting messages
U (unrecoverable)	U messages only
S (severe)	All S and U messages
E (error)	All E, S, and U messages
W (warning)	All W, E, S, and U messages
I (informational)	All messages

When you specify the second parameter, each syntax-error message (except a U-level message) is embedded in the source listing at the point where the compiler had enough information to detect that error. All embedded messages (except those issued by the library compiler phase) directly follow the statement to which they refer. The number of the statement that had the error is also included with the message. Embedded messages are repeated with the rest of the diagnostic messages at the end of the source listing.

Note: You can suppress some error messages and change the severity of others with the MSGEXIT suboption of the EXIT option.

When you specify the NOSOURCE compiler option, the syntax-error messages are included only at the end of the listing. Messages for unrecoverable errors are not embedded in the source listing, because an error of this severity terminates the compilation.

“Example: embedded messages” on page 393

RELATED TASKS

“Generating a list of compiler messages” on page 280

RELATED REFERENCES

“Severity codes for compiler diagnostic messages” on page 282

“Messages and listings for compiler-detected errors” on page 280

“FLAG” on page 328

Example: embedded messages

The following example shows the embedded messages generated by specifying a second parameter to the FLAG option. Some messages in the summary apply to more than one COBOL statement.

```

LineID  PL SL  ----+*A-1-B--+----2-+----3-+----4-+----5-+----6-+----7-|+----8  Map and Cross Reference
...
090671**      /
090672**      *****
090673**      ***          I N I T I A L I Z E   P A R A G R A P H          **
090674**      *** Open files. Accept date, time and format header lines.  **
090675**      *** Load location-table.                                     **
090676**      *****
090677**      100-initialize-paragraph.
090678**      move spaces to ws-transaction-record                        IMP 331
090679**      move spaces to ws-commuter-record                        IMP 307
090680**      move zeroes to commuter-zipcode                         IMP 318
090681**      move zeroes to commuter-home-phone                     IMP 319
090682**      move zeroes to commuter-work-phone                     IMP 320
090683**      move zeroes to commuter-update-date                    IMP 324
090684**      open input update-transaction-file                      204
==090684==> IGYP2052-S An error was found in the definition of file "LOCATION-FILE". The
reference to this file was discarded.
090685**      location-file                                           193
090686**      i-o commuter-file                                       181
090687**      output print-file                                       217
090688**      if commuter-file-status not = "00" and not = "97"      241
090689**      1 display "100-OPEN"
090690**      1 move 100 to comp-code                                  231
090691**      1 perform 500-vsam-error                                91069
090692**      1 perform 900-abnormal-termination                      91114
090693**      end-if
090694**      accept ws-date from date                                UND
==090694==> IGYP2121-S "WS-DATE" was not defined as a data-name. The statement was discarded.
090695**      move corr ws-date to header-date                          UND 455
==090695==> IGYP2121-S "WS-DATE" was not defined as a data-name. The statement was discarded.
090696**      accept ws-time from time                                  UND
==090696==> IGYP2121-S "WS-TIME" was not defined as a data-name. The statement was discarded.
090697**      move corr ws-time to header-time                          UND 449
==090697==> IGYP2121-S "WS-TIME" was not defined as a data-name. The statement was discarded.
090698**      read location-file                                       193
==090698==> IGYP2053-S An error was found in the definition of file "LOCATION-FILE". This
input/output statement was discarded.
090699**      at end
090700**      1 set location-eof to true                                256
090701**      end-read
...
LineID  Message code  Message text
IGYSC0090-W 1700 sequence errors were found in this program.
IGYSC3002-I A severe error was found in the program. The "OPTIMIZE" compiler option was cancelled.
160 IGYDS1089-S "ASSIGN" was invalid. Scanning was resumed at the next area "A" item, level-number, or
the start of the next clause.
193 IGYGR1207-S The "ASSIGN" clause was missing or invalid in the "SELECT" entry for file "LOCATION-FILE".
The file definition was discarded.
269 IGYDS1066-S "REDEFINES" object "WS-DATE" was not the immediately preceding level-1 data item.
The "REDEFINES" clause was discarded.
90602 IGYP2052-S An error was found in the definition of file "LOCATION-FILE". The reference to this file
was discarded. Same message on line: 90684
90694 IGYP2121-S "WS-DATE" was not defined as a data-name. The statement was discarded.
Same message on line: 90695
90696 IGYP2121-S "WS-TIME" was not defined as a data-name. The statement was discarded.
Same message on line: 90697
90698 IGYP2053-S An error was found in the definition of file "LOCATION-FILE". This input/output statement
was discarded. Same message on line: 90709
Messages Total Informational Warning Error Severe Terminating
Printed: 13 1 1 11
* Statistics for COBOL program IGYTCARA:
* Source records = 1755
* Data Division statements = 295
* Procedure Division statements = 479
* Generated COBOL statements = 0
* Program complexity factor = 486
End of compilation 1, program IGYTCARA, highest severity 12.
Return code 12

```

Finding program entity definitions and references

Use the XREF(FULL) compiler option to find out where a data-name, procedure-name, or program-name is defined and referenced. Use it also to produce a cross-reference of COPY or BASIS statements to the data sets or files from which copybooks were obtained.

A sorted cross-reference includes the line number where the data-name, procedure-name, or program-name was defined and the line numbers of all references to it.

To include only the explicitly referenced data items, use the XREF(SHORT) option.

Use both the XREF (either FULL or SHORT) and the SOURCE options to print a modified cross-reference to the right of the source listing. This embedded cross-reference shows the line number where the data-name or procedure-name was defined.

For further details, see the related reference about the XREF compiler option.

“Example: XREF output: data-name cross-references” on page 421

“Example: XREF output: program-name cross-references” on page 422

“Example: XREF output: COPY/BASIS cross-references” on page 422

“Example: XREF output: embedded cross-reference” on page 423

RELATED TASKS

“Getting listings” on page 395

RELATED REFERENCES

“XREF” on page 374

Listing data items

Use the MAP(HEX|DEC) compiler option to create a listing of the DATA DIVISION items and all implicitly declared items. Use the MAP output to locate the contents of a data item in a system dump.

When you specify the MAP(HEX|DEC) option, an embedded MAP summary that contains condensed MAP information is generated to the right of the COBOL source data definition.

- If you specify MAP(HEX) or MAP with no suboption, data item offsets within groups will be in hexadecimal notation.
- If you specify MAP(DEC), data item offsets within groups will be in decimal notation.

When both XREF data and an embedded MAP summary are on the same line, the embedded summary is printed first.

You can select or inhibit parts of the MAP listing and embedded MAP summary by using *CONTROL MAP|NOMAP (or *CBL MAP|NOMAP) statements throughout the source. For example:

```
*CONTROL NOMAP
  01 A
  02 B
*CONTROL MAP
```

“Example: MAP output” on page 400

RELATED TASKS
"Getting listings"

RELATED REFERENCES
"MAP" on page 335

Using the debugger

You can use Debug Tool to debug your Enterprise COBOL programs. Use the TEST compiler option to prepare your COBOL program so that you can step through the executable program with the debugger.

For remote debugging, there is an Eclipse plugin that provides a client graphical user interface to the debugging information provided by the Debug Tool engine running under z/OS or z/OS UNIX. The IBM Debug Tool Plug-in for Eclipse is included with Rational Developer for System z and also with the IBM Problem Determination Tools Studio.

You can specify the TEST suboption NOSOURCE to have smaller object programs stored on disk. The loaded size does not change, the debug information is never loaded unless requested, for example, by a debugger such as Debug Tool or by LE (for CEEDUMP). With the NOSOURCE suboption, you will not be able to see the source in the Debug Tool source window.

Specify the OPTIMIZE(0), NOSTGOPT and TEST compiler options to get the most debugging function.

Specify a non-zero OPTIMIZE level, NOSTGOPT and TEST(EJPD) compiler options to get better performance with a few restrictions on debugging function.

Specify a non-zero OPTIMIZE level, STGOPT and TEST(NOEJPD) compiler options to get the best performance but still be able to use Debug Tool, with some restrictions on debugging function.

For details about which compiler options to use for maximum debugging capability versus best performance, see the related reference about the TEST compiler option.

RELATED TASKS
Debug Tool User's Guide (Preparing your program for debugging)

RELATED REFERENCES
"TEST" on page 364

Getting listings

Get the information that you need for debugging by requesting the appropriate compiler listing with the use of compiler options.

Attention: The listings produced by the compiler are not a programming interface and are subject to change.

Table 50. Using compiler options to get listings

Use	Listing	Contents	Compiler option
To check a list of the options in effect for the program, statistics about the content of the program, and diagnostic messages about the compilation	Short listing	<ul style="list-style-type: none"> • List of options in effect for the program • Statistics about the content of the program • Diagnostic messages about the compilation¹ 	NOSOURCE, NOXREF, NOVBREF, NOMAP, NOOFFSET, NOLIST
To aid in testing and debugging your program; to have a record after the program has been debugged	Source listing	Copy of your source	"SOURCE" on page 357
To find certain data items in a storage dump; to see the final storage allocation after reentrancy or optimization has been accounted for; to see where programs are defined and check their attributes	Map of DATA DIVISION items	<p>All DATA DIVISION items and all implicitly declared items</p> <p>Embedded map summary (in the right margin of the listing for lines in the DATA DIVISION that contain data declarations)</p> <p>Nested program map (if the program contains nested programs)</p>	"MAP" on page 335 ²
To find where a name is defined, referenced, or modified; to determine the context (such as whether a verb was used in a PERFORM block) in which a procedure is referenced; to determine the data set or file from which a copybook was obtained	Sorted cross-reference listing of names; sorted cross-reference listing of COPY/BASIS statements and copybook data sets or files	<p>Data-names, procedure-names, and program-names; references to these names</p> <p>COPY/BASIS text-names and library names, and the data sets or files from which associated copybooks were obtained</p> <p>Embedded modified cross-reference provides line numbers where data-names and procedure-names were defined</p>	"XREF" on page 374 ^{2,3}
To find the failing verb in a program or the address in storage of a data item that is moved while the program is running	PROCEDURE DIVISION code and assembler code produced by the compiler ³	Generated code	"LIST" on page 334 ^{2,4}
To verify you still have a valid logic path after you move or add PROCEDURE DIVISION sections	Condensed PROCEDURE DIVISION listing	Condensed verb listing, global tables, WORKING-STORAGE information, and literals	"OFFSET" on page 345
To find an instance of a certain verb	Alphabetic listing of verbs	Each verb used, number of times each verb was used, line numbers where each verb was used	"VBREF" on page 370

Table 50. Using compiler options to get listings (continued)

Use	Listing	Contents	Compiler option
1.	To eliminate messages, turn off the options (such as FLAG) that govern the level of compile diagnostic information. You can also selectively suppress messages by using the MSGEXIT suboption of the EXIT compiler option.		
2.	To use your line numbers in the compiled program, use the NUMBER compiler option. The compiler checks the sequence of your source statement line numbers in columns 1 through 6 as the statements are read in. When it finds a line number out of sequence, the compiler assigns to it a number with a value one higher than the line number of the preceding statement. The new value is flagged with two asterisks. A diagnostic message indicating an out-of-sequence error is included in the compilation listing.		
3.	The context of the procedure reference is indicated by the characters preceding the line number.		
4.	You can control the listing of generated object code by selectively placing *CONTROL LIST and *CONTROL NOLIST (or equivalently, *CBL LIST and *CBL NOLIST) statements in your source. Note that the *CONTROL statement is different than the PROCESS (or CBL) statement. The output is generated if: <ul style="list-style-type: none"> You specify the COMPILE option (or the NOCOMPILE(x) option is in effect and an error level x or higher does not occur). You do not specify the OFFSET option. OFFSET and LIST are mutually exclusive options with OFFSET taking precedence. 		

"Example: short listing"

"Example: SOURCE and NUMBER output" on page 399

"Example: MAP output" on page 400

"Example: embedded map summary" on page 402

"Example: nested program map" on page 405

"Example: XREF output: data-name cross-references" on page 421

"Example: XREF output: program-name cross-references" on page 422

"Example: XREF output: COPY/BASIS cross-references" on page 422

"Example: XREF output: embedded cross-reference" on page 423

"Example: OFFSET compiler output" on page 424

"Example: VBREF compiler output" on page 425

RELATED TASKS

"Generating a list of compiler messages" on page 280

"Reading LIST output" on page 405

Language Environment Debugging Guide (Debugging COBOL programs)

RELATED REFERENCES

"Messages and listings for compiler-detected errors" on page 280

Example: short listing

The parenthetical numbers shown in the listing below correspond to numbered explanations that follow the listing. For illustrative purposes, some errors that cause diagnostic messages were deliberately introduced.

```

Invocation parameters:      (1)
OPTFILE
PROCESS(CBL) statements:   (2)
CBL NODECK
CBL NOADV,NODYN,NONAME,NONUMBER,QUOTE,SEQ,DUMP
CBL NOSOURCE, NOXREF, NOVREF, NOMAP, NOOFFSET, NOLIST
Options from SYSOPTF:      (3)
C,NODU,FLAG(1),X,MAP,NOLIST,RENT,OPT(1),SSR
TEST TRUNC(OPT)
Options in effect:         (4)
NOADATA
NOADV
AFP(VOLATILE)

```

QUOTE
 ARCH(7)
 ARITH(COMPAT)
 NOAWO
 NOBLOCK0
 BUFSIZE(4096)
 NOCICS
 CODEPAGE(1140)
 COMPILE
 NOCOPYRIGHT
 NOCURRENCY
 DATA(31)
 DBCS
 NODECK
 NODIAGTRUNC
 DISPSIGN(COMPAT)
 NODLL
 DUMP
 NODYNAM
 NOEXIT
 NOEXPORTALL
 NOFASTSRT
 FLAG(I)
 NOFLAGSTD
 HGPR(PRESERVE)
 INTDATE(ANSI)
 LANGUAGE(EN)
 LINECOUNT(60)
 NOLIST
 NOMAP
 MAXPCF(60000)
 NOMDECK
 NONAME
 NSYMBOL(NATIONAL)
 NONUMBER
 NUMPROC(NOPFD)
 OBJECT
 NOOFFSET
 OPTIMIZE(1)
 OUTDD(SYSOUT)
 PGMNAME(COMPAT)
 QUALIFY(COMPAT)
 RENT
 RMODE(AUTO)
 NORULES
 NOSERVICE
 SEQUENCE
 NOSOURCE
 SPACE(1)
 NOSQL
 SQLCCSID
 NOSQLIMS
 SSRANGE
 NOSTGOPT
 NOTERM
 TEST(NOJPD,SOURCE)
 NOTHREAD
 TRUNC(OPT)
 NOVBREF
 VLR(COMPAT)
 VSAMOPENFS(COMPAT)
 NOWORD
 XMLPARSE(XMLSS)
 NOXREF
 ZONEDATA(PFD)
 ZWB

LineID Message code Message text (5)

	IGYSC3002-I	A severe error was found in the program. The "OPTIMIZE" and the "STGOPT" compiler options were cancelled.
160	IGYDS1089-S	"ASSIGN" was invalid. Scanning was resumed at the next area "A" item, level-number, or the start of the next clause.
192	IGYDS1050-E	File "LOCATION-FILE" contained no data record descriptions. The file definition was discarded.
192	IGYGR1207-S	The "ASSIGN" clause was missing or invalid in the "SELECT" entry for file "LOCATION-FILE". The file definition was discarded.
888	IGYPS2052-S	An error was found in the definition of file "LOCATION-FILE". The reference to this file

```

was discarded.
Same message on line: 979
1000 IGYPS2121-S "WS-DATE" was not defined as a data-name. The statement was discarded.
Same message on line: 1001
1004 IGYPS2053-S An error was found in the definition of file "LOCATION-FILE". This input/output statement
was discarded.
Same message on line: 1016
1015 IGYPS2121-S "LOC-CODE" was not defined as a data-name. The statement was discarded.
1212 IGYPS2121-S "WS-NUMERIC-DATE" was not defined as a data-name. The statement was discarded.
1655 IGYPG3113-W Truncation of high-order digit positions may occur due to precision of intermediate results
exceeding 30 digits.
Messages Total Informational Warning Error Severe Terminating (6)
Printed: 13 1 1 1 10
* Statistics for COBOL program IGYTCARA: (7)
* Source records = 1755
* Data Division statements = 295
* Procedure Division statements = 479
* Generated COBOL statements = 0
* Program complexity factor = 486
End of compilation 1, program IGYTCARA, highest severity 12. (8)
Return code 12

```

- (1) Message about options passed to the compiler at compiler invocation. This message does not appear if no options were passed.

OPTFILE

Requests options from a SYSOPTF data set.

- (2) Options coded in the PROCESS (or CBL) statement.

NOOFFSET

Suppresses a condensed listing of the PROCEDURE DIVISION.

NOMAP Suppresses a map report of the items defined in the DATA DIVISION.

- (3) Options obtained from the SYSOPTF data set (because the OPTFILE compiler option was specified).

NOLIST Suppresses an assembler-language expansion of the source code.

TEST The program was compiled for use with debugging and problem determination tools (such as Debug Tool and Fault Analyzer) and to get local variables listed in CEEDUMP.

- (4) Status of options at the start of this compilation.
- (5) Program diagnostics. The first message refers you to any library phase diagnostics. Diagnostics for the library phase are presented at the beginning of the listing.
- (6) Count of diagnostic messages in this program, grouped by severity level.
- (7) Program statistics for the program IGYTCARA.
- (8) Program statistics for the compilation unit. When you perform a batch compilation, the return code is the highest message severity level for the entire compilation.

Example: SOURCE and NUMBER output

In the portion of the listing shown below, the programmer numbered two of the statements out of sequence. The note numbers in the listing correspond to numbered explanations that follow the listing.

```

(1)
LineID PL SL (2) (3) (4) (1)
000870 /*****
000871 *** DO MAIN LOGIC **

```

```

000872      ***                               **
000873      *** Initialization. Read and process update transactions until ***
000874      *** EOE. Close files and stop run.                               **
000875      ****
000876      procedure division.
000877      000-do-main-logic.
000878      display "PROGRAM IGYTCARA - Beginning".
000879      perform 050-create-vsam-master-file.                               930
000880      perform 100-initialize-paragraph.                                 982
000881      read update-transaction-file into ws-transaction-record        203 338
000882      at end
000883      1 IA4390      set transaction-eof to true                          253
000884      end-read.
000885      IA4410      perform until transaction-eof                          253
000886      1          perform 200-edit-update-transaction                  1050
000887      1 IA4430      if no-errors                                      372
000888      2          perform 300-update-commuter-record                  1159
000889      1          else
000890      2          perform 400-print-transaction-errors                  1312
000891      1          end-if
000892      1          perform 410-re-initialize-fields                       1373
000893      1 IA4480      read update-transaction-file into ws-transaction-record 203 338
000894      1          at end
000895      2 IA4500      set transaction-eof to true                          253
000896      1 IA4510      end-read
000897      IA4520      end-perform.
000898      close commuter-file update-transaction-file location-file      180 203 192
000899      print-file.                                                    216
000900
000901      *-----*
000902      * File status checked after I/O operation. *
000903      *-----*
000904
000905      IA4600      if not i-o-okay                                       241
000906      1          display "000-close"
000907      1          move 0000 to comp-code                                  230
000908      1 IA4620      perform 500-vsam-error                             1386
000909      1          perform 900-abnormal-termination                      1432
000910      IA4630      end-if.
000911      *****
000912      * Paragraphs 1100 and 1200 illustrates the intrinsic *
000913      * function computations. *
000914      *****
000915      perform 1100-print-i-f-headings.                                  1441
000916      perform 1200-print-i-f-data.                                    1481
000917      display " ".
000918      display " ".
000919      display "PROGRAM IGYTCARA - Normal end".
000920      stop run.

```

- (1) Scale line, which labels Area A, Area B, and source-code column numbers
- (2) Source-code line number assigned by the compiler
- (3) Program (PL) and statement (SL) nesting level
- (4) Columns 1 through 6 of program (the sequence number area)

Example: MAP output

The following example shows output from the MAP option. The numbers used in the explanation below correspond to the numbers that annotate the output.

```

Data Division Map
(1)
Data Definition Attribute codes (rightmost column) have the following meanings:
D = Object of OCCURS DEPENDING      G = GLOBAL                          S = Spanned file
E = EXTERNAL                          O = Has OCCURS clause              U = Undefined format file
F = Fixed-length file                 OG= Group has own length definition V = Variable-length file
FB= Fixed-length blocked file         R = REDEFINES                       VB= Variable-length blocked file
X = Unallocated

(2)  (3)  (4)  (5)  (6)  (7)  (8)  (9)
Source Hierarchy and Base Displacement Asmblr Data Data Type Data Def
LineID Data Name Locator Structure Definition Definition Attributes
-----
4  PROGRAM-ID IGYTCARA-----
58  FD  COMMUTER-FILE . . . . . BLF=00001
60  1  COMMUTER-RECORD . . . . . BLF=00001
61  2  COMMUTER-KEY. . . . . BLF=00001 000000000 DS 0CL80
62  2  FILLER. . . . . BLF=00001 000000016 DS 16C
64  FD  COMMUTER-FILE-MST . . . . . BLF=00002
66  1  COMMUTER-RECORD-MST . . . . . BLF=00002
67  2  COMMUTER-KEY-MST. . . . . BLF=00002 000000000 DS 0CL80
68  2  FILLER. . . . . BLF=00002 000000016 DS 16C
140 1  STATUS-AREA . . . . .
141 2  COMMUTER-FILE-STATUS. . . . . 000000000 DS 0CL8
142 88 I-O-OKAY. . . . .
143 2  COMMUTER-VSAM-STATUS. . . . . 000000002 DS 2C
144 3  VSAM-R15-RETURN-CODE. . . . . 000000002 DS 16C
145 3  VSAM-FUNCTION-CODE. . . . . 000000004 DS 64C
146 3  VSAM-FEEDBACK-CODE. . . . . 000000006 DS 2C
148 77 UPDATE-FILE-STATUS. . . . . DS 2C
149 77 LOCCODE-FILE-STATUS. . . . . DS 2C
150 77 UPDPRINT-FILE-STATUS. . . . . DS 2C
152 1  FLAGS . . . . . DS 0CL3
153 2  TRANSACTION-EOF-FLAG. . . . . 000000000 DS 1C
154 88 TRANSACTION-EOF . . . . .
155 2  LOCATION-EOF-FLAG . . . . . 000000001 DS 1C
156 88 LOCATION-EOF. . . . .
157 2  TRANSACTION-MATCH-FLAG. . . . . 000000002 DS 1C

```



```

158 88 TRANSACTION-MATCH . . . . .
159 88 TRANSACTION-MATCH-OFF . . . . .
216 1 WS-COMMUTER-RECORD. . . . . BLX=00001 DS 0CL81 Group E
217 2 WS-COMMUTER-KEY . . . . . BLX=00001 000000000 DS 0CL16 Group E
218 3 WS-COMMUTER-GENERIC-KEY . . . . . BLX=00001 000000000 DS 0CL5 Group E
219 4 COMMUTER-SHIFT . . . . . BLX=00001 000000000 DS 1C Display E
220 4 COMMUTER-HOME-CODE. . . . . BLX=00001 000000001 DS 2C Display E
221 4 COMMUTER-WORK-CODE. . . . . BLX=00001 000000003 DS 2C Display E
222 3 COMMUTER-NAME . . . . . BLX=00001 000000005 DS 9C Display E
223 3 COMMUTER-INITIALS . . . . . BLX=00001 000000014 DS 2C Display E
224 2 COMMUTER-ADDRESS. . . . . BLX=00001 000000016 DS 18C Display E
225 2 COMMUTER-CITY . . . . . BLX=00001 000000034 DS 13C Display E
226 2 COMMUTER-STATE. . . . . BLX=00001 000000047 DS 2C Display E
227 2 COMMUTER-ZIPCODE. . . . . BLX=00001 000000049 DS 3P Packed-Dec E
396 1 DETAIL1-LINE. . . . . BLL=00001 DS 0CL121 Group
397 2 FILLER. . . . . BLL=00001 000000000 DS 2C Display
398 2 PRINT-TRANSACTION-CODE. . . . . BLL=00001 000000002 DS 1C Display
399 2 FILLER. . . . . BLL=00001 000000003 DS 4C Display
400 2 PRINT-RECORD-TYPE . . . . . BLL=00001 000000007 DS 3C Display
401 2 FILLER. . . . . BLL=00001 000000010 DS 3C Display
402 2 PRINT-SHIFT . . . . . BLL=00001 000000013 DS 1C Display
403 2 FILLER. . . . . BLL=00001 000000014 DS 1C Display
404 2 PRINT-HOME-CODE . . . . . BLL=00001 000000015 DS 2C Display
405 2 FILLER. . . . . BLL=00001 000000017 DS 1C Display
406 2 PRINT-WORK-CODE . . . . . BLL=00001 000000018 DS 2C Display
407 2 FILLER. . . . . BLL=00001 000000020 DS 2C Display
408 2 PRINT-NAME. . . . . BLL=00001 000000022 DS 9C Display
454 1 DETAILX-LINE. . . . . BLL=XXXX DS 0CL121 Group X
455 2 FILLER. . . . . BLL=XXXX DS 36C Display X
456 2 PRINT-CITY. . . . . BLL=XXXX DS 13C Display X
457 2 FILLER. . . . . BLL=XXXX DS 3C Display X
458 2 PRINT-STATE . . . . . BLL=XXXX DS 2C Display X
459 2 FILLER. . . . . BLL=XXXX DS 1C Display X
460 2 PRINT-ZIPCODE . . . . . BLL=XXXX DS 5C Display X
461 2 FILLER. . . . . BLL=XXXX DS 1C Display X
462 2 PRINT-WORK-PHONE. . . . . BLL=XXXX DS 14C Display X
463 2 FILLER. . . . . BLL=XXXX DS 1C Display X
464 2 PRINT-WORK-JUNCTION . . . . . BLL=XXXX DS 25C Display X
465 2 FILLER. . . . . BLL=XXXX DS 20C Display X (10)
467 1 DETAIL2-LINE. . . . . BLL=00002 DS 0CL121 Group
468 2 FILLER. . . . . BLL=00002 000000000 DS 36C Display
469 2 PRINT-CITY. . . . . BLL=00002 000000036 DS 13C Display
470 2 FILLER. . . . . BLL=00002 000000049 DS 3C Display
471 2 PRINT-STATE . . . . . BLL=00002 000000052 DS 2C Display
472 2 FILLER. . . . . BLL=00002 000000054 DS 1C Display
473 2 PRINT-ZIPCODE . . . . . BLL=00002 000000055 DS 5C Display
474 2 FILLER. . . . . BLL=00002 000000060 DS 1C Display
475 2 PRINT-WORK-PHONE. . . . . BLL=00002 000000061 DS 14C Display
476 2 FILLER. . . . . BLL=00002 000000075 DS 1C Display
477 2 PRINT-WORK-JUNCTION . . . . . BLL=00002 000000076 DS 25C Display
478 2 FILLER. . . . . BLL=00002 000000101 DS 20C Display

```

- (1) Explanations of the data definition attribute codes.
- (2) Source line number where the data item was defined.
- (3) Level definition or number. The compiler generates this number in the following way:
 - First level of any hierarchy is always 01. Increase 1 for each level (any item you coded as level 02 through 49).
 - Level-numbers 66, 77, and 88, and the indicators FD and SD, are not changed.
- (4) Data-name that is used in the source module in source order.
- (5) Base locator used for this data item.
- (6) Hexadecimal displacement from the beginning of the containing structure if the MAP(HEX) option is in effect. If the MAP(DEC) option is in effect, decimal displacement is shown.
- (7) Pseudoassembler code showing how the data is defined. When a structure contains variable-length fields, the maximum length of the structure is shown.
- (8) Data type and usage.
- (9) Data definition attribute codes. The definitions are explained at the top of the DATA DIVISION map.
- (10) DETAILX-LINE was not referenced in the PROCEDURE DIVISION. Because STGOPT was specified, DETAILX-LINE was deleted, resulting in the base locator being set to XXXXX.

"Example: embedded map summary"

"Example: nested program map" on page 405

RELATED REFERENCES

"Terms used in MAP output" on page 403

"Symbols used in LIST and MAP output" on page 404

Example: embedded map summary

The following example shows an embedded map summary from specifying the MAP option. The summary appears in the right margin of the listing for lines in the DATA DIVISION that contain data declarations.

```
000002 Identification Division.
000003
000004 Program-id. IGYTCARA.
. . .
000054 Data division.
000055 File section.
000056
000058 FD COMMUTER-FILE
000059 record 80 characters.
. . .
000060 01 commuter-record.
000061 05 commuter-key PIC x(16).
000062 05 filler PIC x(64).
. . .
000105 Working-storage section.
000106 01 Working-storage-for-IGYTCARA pic x.
000107
000108 77 comp-code pic S9999 comp.
000109 77 ws-type pic x(3) value spaces.
000135 01 i-f-status-area.
000136 05 i-f-file-status pic x(2).
000137 88 i-o-successful value zeroes.
000138
000139
000140 01 status-area.
000141 05 commuter-file-status pic x(2).
000142 88 i-o-okay value zeroes.
000143 05 commuter-vsam-status.
000144 10 vsam-r15-return-code pic 9(2) comp.
000145 10 vsam-function-code pic 9(1) comp.
000146 10 vsam-feedback-code pic 9(3) comp.
000147
000148 77 update-file-status pic xx.
000149 77 loccode-file-status pic xx.
000150 77 updprint-file-status pic xx.
000151
000216 01 ws-commuter-record EXTERNAL.
000217 05 ws-commuter-key.
000218 10 ws-commuter-generic-key.
000219 15 commuter-shift pic x.
000220 15 commuter-home-code pic xx.
000221 15 commuter-work-code pic xx.
000222 10 commuter-name pic x(9).
000223 10 commuter-initials pic xx.
000224 05 commuter-address pic x(18).
000225 05 commuter-city pic x(13).
000226 05 commuter-state pic xx.
000227 05 commuter-zipcode pic 9(5) comp-3.
. . .
000395 Linkage Section.
000396 01 detail1-line.
000397 05 filler pic xx.
000398 05 print-transaction-code pic x.
000399 05 filler pic x(4).
000400 05 print-record-type pic x(3).
000401 05 filler pic xxx.
000402 05 print-shift pic x.
000403 05 filler pic x.
000404 05 print-home-code pic xx.
000405 05 filler pic x.
000406 05 print-work-code pic xx.
000407 05 filler pic xx.
000408 05 print-name pic x(9).
000409 05 filler pic xx.
000410 05 print-initials pic xx.
. . .
000487 procedure division.
000488 000-do-main-logic.
000489 display "PROGRAM IGYTCARA - Beginning".
```

(1) Base locator used for this data item

- (2) Decimal displacement from the beginning of the containing structure. It indicates that the MAP(DEC) option is in effect. If you specified the MAP(HEX) option or MAP with no suboption, hexadecimal displacement is shown.
- (3) Pseudoassembler code showing how the data is defined

RELATED REFERENCES

“Symbols used in LIST and MAP output” on page 404

Terms used in MAP output

The following table describes the terms used in the listings produced by the MAP compiler option.

Table 51. Terms used in MAP output

Term	Definition	Description
ALPHABETIC	DS <i>n</i> C	Alphabetic data item (PICTURE A)
ALPHA-EDIT	DS <i>n</i> C	Alphabetic-edited data item
AN-EDIT	DS <i>n</i> C	Alphanumeric-edited data item
BINARY	DS 1H ² , 1F ² , 2F ² , 2C, 4C, or 8C	Binary data item (USAGE BINARY, COMPUTATIONAL, or COMPUTATIONAL-5)
COMP-1	DS 4C	Single-precision internal floating-point data item (USAGE COMPUTATIONAL-1)
COMP-2	DS 8C	Double-precision internal floating-point data item (USAGE COMPUTATIONAL-2)
DBCS	DS <i>n</i> C	DBCS data item (USAGE DISPLAY-1)
DBCS-EDIT	DS <i>n</i> C	DBCS-edited data item (USAGE DISPLAY-1)
DISP-FLOAT	DS <i>n</i> C	Display floating-point data item (USAGE DISPLAY)
DISPLAY	DS <i>n</i> C	Alphanumeric data item (PICTURE X)
DISP-NUM	DS <i>n</i> C	Zoned decimal data item (USAGE DISPLAY)
DISP-NUM-EDIT	DS <i>n</i> C	Numeric-edited data item (USAGE DISPLAY)
FD		File definition
FUNCTION-PTR	DS <i>n</i> C	Function pointer (USAGE FUNCTION-POINTER)
GROUP	DS 0CL <i>n</i> ¹	Fixed-length alphanumeric group data item
GRP-VARLEN	DS 0CL <i>n</i> ¹	Variable-length alphanumeric group data item
INDEX	DS <i>n</i> C	Index data item (USAGE INDEX)
INDEX-NAME	DS <i>n</i> C	Index name
NATIONAL	DS <i>n</i> C	Category national data item (USAGE NATIONAL)
NAT-EDIT	DS <i>n</i> C	National-edited data item (USAGE NATIONAL)
NAT-FLOAT	DS <i>n</i> C	National floating-point data item (USAGE NATIONAL)
NAT-GROUP	DS 0CL <i>n</i> ¹	National group (GROUP-USAGE NATIONAL)
NAT-GRP-VARLEN	DS 0CL <i>n</i> ¹	National variable-length group (GROUP-USAGE NATIONAL)
NAT-NUM	DS <i>n</i> C	National decimal data item (USAGE NATIONAL)
NAT-NUM-EDIT	DS <i>n</i> C	National numeric-edited data item (USAGE NATIONAL)
OBJECT-REF	DS <i>n</i> C	Object-reference data item (USAGE OBJECT REFERENCE)
PACKED-DEC	DS <i>n</i> P	Internal decimal data item (USAGE PACKED-DECIMAL or COMPUTATIONAL-3)
POINTER	DS <i>n</i> C	Pointer data item (USAGE POINTER)

Table 51. Terms used in MAP output (continued)

Term	Definition	Description
PROCEDURE-PTR	DS <i>n</i> C	Procedure pointer (USAGE PROCEDURE-POINTER)
SD		Sort file definition
VSAM, QSAM, LINESEQ		File processing method
1-49, 77		Level-numbers for data descriptions
66		Level-number for RENAMEs
88		Level-number for condition-names
<p>1. <i>n</i> is the size in bytes for fixed-length groups and the maximum size in bytes for variable-length groups.</p> <p>2. If the SYNCHRONIZED clause appears, these fields are used.</p>		

Symbols used in LIST and MAP output

The following table describes the symbols used in the listings produced by the LIST or MAP option.

Table 52. Symbols used in LIST and MAP output

Symbol	Definition
BLF_ <i>n</i> ¹	Base locator for files
BLL_ <i>n</i> ¹	Base locator for LINKAGE SECTION
BLO_ <i>n</i> ¹	Base locator for object instance data
BLT_ <i>n</i> ¹	Base locator for XML-TEXT and XML-NTEXT
BLV_ <i>n</i> ¹	Base locator for variably located data
BLX_ <i>n</i> ¹	Base locator for external data
ODOsv_cell	ODO save cell number
Pfm_cell	PERFORM cell number
Pfm _{sv} _cell	Perform save cell number
TSN=N	Temporary created by the compiler
VLC_cell	Variable-length cell (ODO)
VN_cell	Variable name cell for PERFORM statement
VNGO_cell	Variable name cell for ALTER statement
VNI_cell	Variable name initialization
#Calc00000000n	Code to compute addresses of data that is present after an OCCURS DEPENDING ON clause
#WSVal00000000n	Code to initialize the WORKING-STORAGE area for a procedure
_ArgumentList	Outgoing arguments to a procedure
_ACON	Address of a symbol
_BEtempNNN	Temporary created by the optimizer
_CAA	Address of the start of the Language Environment Common Anchor Area
CACHED\$STATIC	Copy of the start address of the static area (for this procedure)
_CONSTANT_AREA+n	Offset in the Constant Area
_CRENT	Address of the writable static area (for this module), from the CAA
_incomingArgumentList	Incoming parameters to the procedure
_parentDSA	For a nested procedure, it is the address of its parent's stack

Table 52. Symbols used in LIST and MAP output (continued)

Symbol	Definition
_QCON	Offset to a symbol
_returnValue	Return value of the procedure
_VTS_n	Temporary created by the optimizer
1. n is the number of the entry. For base locators, it can also be XXXXX, indicating a data item that was deleted by STGOPT processing.	

Example: nested program map

This example shows a map of nested procedures produced by specifying the MAP compiler option. Numbers in parentheses refer to notes that follow the example.

```

Nested Program Map
Program Attribute codes (rightmost column) have the following meanings:
  C = COMMON
  I = INITIAL (1)
  U = PROCEDURE DIVISION USING... (5)
Source Nesting
LineID Level Program Name from PROGRAM-ID paragraph Program Attributes
   2     0 NESTMAIN. . . . . U
  120    1 (4) SUBPR01 . . . . . I,C,U
(2)199    2 NESTED1 . . . . . I,C,U
   253    1 SUBPR02 . . . . . U
   335    2 NESTED2 . . . . . C,U
(3)

```

- (1) Explanations of the program attribute codes
- (2) Source line number where the program was defined
- (3) Depth of program nesting
- (4) Program-name
- (5) Program attribute codes

Reading LIST output

Parts of the LIST compiler output might be useful to you for debugging a program.

The LIST compiler option produces several pieces of output:

- An assembler listing of the initialization code for the program (program signature information bytes) from which you can verify program characteristics such as:
 - Compiler options in effect
 - Types of data items present
 - Verbs used in the PROCEDURE DIVISION
- An assembler listing of the source code for the program

From the address in storage of the instruction that was executing when an abend occurred, you can find the COBOL verb that corresponds to that instruction. After you find the address of the failing instruction, go to the assembler listing and find the verb for which that instruction was generated. The line number is in the 3rd column of the assembler listing for your program. Using the line number, you can locate the VERB by looking at the corresponding line in the Source Output section of the listing.
- Information about WORKING-STORAGE. This information is contained in the Data Division Map and in the Static Map.

- A description of the writeable static area (WSA) is found in the Static Map or WSA24 Map sections of the listing. The symbols in WORKING-STORAGE area of the source are mapped into the writable static area that is shown in the Static Map. You can use the Data Division Map along with the Static Map section to find the location of data items defined in WORKING-STORAGE. These data items reside in the Writeable Static Area (WSA or WSA24). The Static Map gives the offset of each level-1 data item relative to the beginning of the writable static area. The Data Division Map section gives the offset of the level-*n* data items relative to their respective level-1 member. By using both pieces of information, you can determine the offset of any data member within the writable static area.
If you compile with the DATA24 option, data items mapped below the line will appear in the WSA24 Map. You can follow the same process to determine their locations.
- Information about the constants and the literals used in the program. The Constant Area contains information about the constants and literals in the program, as well as those created by the compiler. This section contains the offset of each constant or literal within the Constant Area.
- Program prolog areas (PPA1, PPA2, PPA3, PPA4) contain information about the characteristics of the compiled program.
- Externals symbols dictionary contains the list of external symbols defined by or referred to, in your program.
- Map of the dynamic save area (DSA)
The map of the DSA (also known as the *stack frame*) contains information about the contents of the storage acquired each time a separately compiled procedure is entered.

You do not need to be able to program in assembler language to understand the LIST output. The comments that accompany most of the assembler code provide you with a conceptual understanding of the functions performed by the code.

“Example: program initialization code” on page 413

“Example: MD5 signature” on page 414

“Example: Timestamp and version information” on page 414

“Example: Compiler options and program information” on page 414

“Example: assembler code generated from source code” on page 415

“Example: Program prolog areas” on page 416

“Example: Static map” on page 417

“Example: Constant area” on page 418

“Example: Base locator table” on page 418

“Example: External symbols” on page 419

“Example: DSA memory map (Automatic map)” on page 420

RELATED REFERENCES

“Signature information bytes”

“Example: MAP output” on page 400

Language Environment Programming Guide (Stack storage overview)

Signature information bytes

The tables in this topic show program signature information that is part of the listing of program initialization code provided when you use the LIST compiler option.

Table 53. Compiler options in the INFO BYTE section

Offset in decimal	Option	Value
00	CODEPAGE	CCSID value specified for EBCDIC code page
02	ARCH	7
		8
		9
		10
		11
03	OPTIMIZE	0
		1
		2

The INFO BYTE section of the listing also provides the following values:

- The number of DATA DIVISION statements
- The number of PROCEDURE DIVISION statements

In the following table, different signature bytes represent different information:

- Signature bytes 1-5, and 26-31 refer to compiler options
- Signature bytes 6-7 refer to DATA DIVISION items
- Signature byte 8 refers to ENVIRONMENT DIVISION items
- Signature bytes 9-25 refer to PROCEDURE DIVISION verbs and items

Table 54. Signature information bytes

Offset in decimal	Signature byte	Bit	Item	
			On	Off
04	28	0	SQL	NOSQL
		1	CICS	NOCICS
		2	MDECK	NOMDECK
		3	SQLCCSID	NOSQLCCSID
		4	OPTFILE	NOOPTFILE
		5	XMLPARSE(XMLSS)	XMLPARSE(COMPAT)
		6	BLOCK0	NOBLOCK0
		7	DISPSIGN(SEP)	DISPSIGN(COMPAT)
05	29	0	Program uses Java-based OO syntax	
		1	Program uses RANDOM function	
		2	Program uses NATIONAL data (Unicode)	
		3	XML PARSE with schema validation	
		4	STGOPT	NOSTGOPT
		5	AFP(VOLATILE)	AFP(NOVOLATILE)
		6	HGPR(PRESERVE)	HGPR(NOPRESERVE)
		7	NOTEST(DWARF)	Not NOTEST(DWARF)

Table 54. Signature information bytes (continued)

Offset in decimal	Signature byte	Bit	Item	
			On	Off
06	30	0	QUALIFY(EXTEND)	QUALIFY(COMPAT)
		1	VLR(COMPAT)	VLR(STANDARD)
		2	COPYRIGHT string specified	COPYRIGHT string unspecified
		3	SERVICE string specified	SERVICE string unspecified
		4	ZONEDATA(MIG)	ZONEDATA(PFD)
		5-7	Reserved	
07	31	0	NUMCHECK(ZON[(ALPHNUM)])	Not NUMCHECK(ZON[(ALPHNUM)])
		1	NUMCHECK(PAC)	Not NUMCHECK(PAC)
		2	NUMCHECK(BIN)	Not NUMCHECK(BIN)
				NONUMCHECK is in effect if bits 0, 1, and 2 are off
		3	NUMCHECK(ABD)	NUMCHECK(MSG) (if any bit of 0, 1, or 2 is on)
		4	PARMCHECK	NOPARMCHECK
		5	PARMCHECK(ABD) (if bit 4 is on)	PARMCHECK(MSG) (if bit 4 is on)
6	NUMCHECK(ZON(NOALPHNUM))	Not NUMCHECK(ZON(NOALPHNUM))		
08	1	0	ADV	NOADV
		1	APOST	QUOTE
		2	DATA(31)	DATA(24)
		3	DECK	NODECK
		4	DUMP	NODUMP
		5	DYNAM	NODYNAM
		6	FASTSRT	NOFASTSRT
		7	SQLIMS	NOSQLIMS
09	2	0	LIB (always on)	
		1	LIST	NOLIST
		2	MAP(HEX), MAP(DEC)	NOMAP
		3	NUM	NONUM
		4	OBJECT	NOOBJECT
		5	OFFSET	NOOFFSET
		6	OPT(1), OPT(2)	NOOPT, OPT(0)
		7	OUTDD	NOOUTDD

Table 54. Signature information bytes (continued)

Offset in decimal	Signature byte	Bit	Item	
			On	Off
10	3	0	NUMPROC (PFD)	NUMPROC (NOPFD)
		1	RENT	NORENT
		2	RESIDENT (always on)	
		3	SEQUENCE	NOSEQUENCE
		4	Reserved	
		5	SOURCE	NOSOURCE
		6	Not NOSSRANGE	NOSSRANGE
		7	TERM	NOTERM
11	4	0	TEST	NOTEST
		1	TRUNC (STD)	Not TRUNC (STD)
		2	WORD	NOWORD
		3	VBREF	NOVBREF
		4	XREF	NOXREF
		5	ZWB	NOZWB
		6	NAME	NONAME
		7		NOCMPR2 (always off)
12	5	0	Reserved	NONUMPROC
		1	NUMCLS=ALT	NUMCLS=PRIM
		2	DBCS	NODBCS
		3	AWO	NOAWO
		4	TRUNC (BIN)	Not TRUNC (BIN)
		5	ADATA	NOADATA
		6	CURRENCY	NOCURRENCY
		7	Compilation unit is a class	Compilation unit is a program
13	6	0	QSAM file descriptor	
		1	VSAM sequential file descriptor	
		2	VSAM indexed file descriptor	
		3	VSAM relative file descriptor	
		4	CODE-SET clause (ASCII files) in file descriptor	
		5	Spanned records	
		6	PIC G or PIC N (DBCS data item)	
		7	OCCURS DEPENDING ON clause in data description entry	

Table 54. Signature information bytes (continued)

Offset in decimal	Signature byte	Bit	Item	
			On	Off
14	7	0	SYNCHRONIZED clause in data description entry	
		1	JUSTIFIED clause in data description entry	
		2	USAGE IS POINTER item	
		3	Complex OCCURS DEPENDING ON clause	
		4	External floating-point items in the DATA DIVISION	
		5	Internal floating-point items in the DATA DIVISION	
		6	Line-sequential file	
		7	USAGE IS PROCEDURE-POINTER or FUNCTION-POINTER item	
15	8	0	FILE STATUS clause in FILE-CONTROL paragraph	
		1	RERUN clause in I-O-CONTROL paragraph of INPUT-OUTPUT SECTION	
		2	UPSI switch defined in SPECIAL-NAMES paragraph	
		4	VSAMOPENFS	
16	9	0	ACCEPT	
		1	ADD	
		2	ALTER	
		3	CALL	
		4	CANCEL	
		6	CLOSE	
17	10	0	COMPUTE	
		2	DELETE	
		4	DISPLAY	
		5	DIVIDE	
18	11	1	END-PERFORM	
		2	ENTER	
		3	ENTRY	
		4	EXIT	
		5	EXEC	
		6	GO TO	
		7	IF	
19	12	0	INITIALIZE	
		1	INVOKE	
		2	INSPECT	
		3	MERGE	
		4	MOVE	
		5	MULTIPLY	
		6	OPEN	
		7	PERFORM	

Table 54. Signature information bytes (continued)

Offset in decimal	Signature byte	Bit	Item	
			On	Off
20	13	0	READ	
		2	RELEASE	
		3	RETURN	
		4	REWRITE	
		5	SEARCH	
		7	SET	
21	14	0	SORT	
		1	START	
		2	STOP	
		3	STRING	
		4	SUBTRACT	
		7	UNSTRING	
22	15	0	USE	
		1	WRITE	
		2	CONTINUE	
		3	END-ADD	
		4	END-CALL	
		5	END-COMPUTE	
		6	END-DELETE	
		7	END-DIVIDE	
23	16	0	END-EVALUATE	
		1	END-IF	
		2	END-MULTIPLY	
		3	END-READ	
		4	END-RETURN	
		5	END-REWRITE	
		6	END-SEARCH	
		7	END-START	
24	17	0	END-STRING	
		1	END-SUBTRACT	
		2	END-UNSTRING	
		3	END-WRITE	
		4	GOBACK	
		5	EVALUATE	
		7	SERVICE	

Table 54. Signature information bytes (continued)

Offset in decimal	Signature byte	Bit	Item		
			On	Off	
25	18	0	END-INVOKE		
		1	END-EXEC		
		2	XML		
		3	END-XML		
26	19	0-7	Reserved		
27	20	0-7	Reserved		
28	21	0	Hexadecimal literal		
		1	Altered GO TO		
		2	I-O ERROR declarative		
		3	LABEL declarative		
		4	DEBUGGING declarative		
		5	Program segmentation		
		6	OPEN . . . EXTEND		
		7	EXIT PROGRAM		
29	22	0	CALL literal		
		1	CALL identifier		
		2	CALL . . . ON OVERFLOW		
		3	CALL . . . LENGTH OF		
		4	CALL . . . ADDRESS OF		
		5	CLOSE . . . REEL/UNIT		
		6	Exponentiation used		
		7	Floating-point items used		
30	23	0	COPY		
		1	BASIS		
		2	DBCS name in program		
		3	Shift-out and Shift-in in program		
		4	Reserved		
		5	SSRANGE(ZLEN) (if bit 6 in byte 3 is on)	SSRANGE(NOZLEN) (if bit 6 in byte 3 is on)	
		6	SSRANGE(ABD) (if bit 6 in byte 3 is on)	SSRANGE(MSG) (if bit 6 in byte 3 is on)	
		7	Reserved		
40	24	0	DBCS literal		
		1	REPLACE		
		2	Reference modification was used.		
		3	Nested program		
		4	INITIAL		
		5	COMMON		
		6	SELECT . . . OPTIONAL		
		7	EXTERNAL		

Table 54. Signature information bytes (continued)

Offset in decimal	Signature byte	Bit	Item	
			On	Off
41	25	0	GLOBAL	
		1	RECORD IS VARYING	
		2	VOLATILE	
		5	Intrinsic function was used	
		6	Z-literal found	
		7	RECURSIVE	
42	26	0	RMODE(ANY)	Not RMODE(ANY)
		1-3	Reserved	
		4	Reserved	
		5	INTDATE(LILIAN)	INTDATE(ANSI)
		6	Reserved	
		7	Reserved	
43	27	0	PGMNAME(LONGUPPER)	Not PGMNAME(LONGUPPER)
		1	PGMNAME(LONGMIXED)	Not PGMNAME(LONGMIXED)
		2	DLL	NODLL
		3	EXPORTALL	NOEXPORTALL
		4	TEST(SOURCE)	Not TEST(SOURCE)
		5	ARITH(EXTEND)	ARITH(COMPAT)
		6	THREAD	NOTHREAD
		7	TEST(EJPD)	TEST(NOEJPD)

Check return code: A return code greater than 4 from the compiler could mean that some of the verbs shown in the information bytes might have been discarded from the program.

RELATED REFERENCES
"LIST" on page 334

Example: program initialization code

A listing of the program initialization code gives you information about the characteristics of the COBOL source program. Interpret the program signature information bytes to verify characteristics of your program.

```

(1)      (2)      (3)      (4)      (5)
000000          000003      PROC      IGYTCARA
000000      47F0 F014      000003      BC      R15,20(,R15)      # Skip over constant area
000004      01C3 C5C5      000003      DC      X'01C3C5C5'      # Eyecatcher: CEE
000008      0000 0978      000003      DC      X'00000978'      # Stack Size
00000C      0000 8910      000003      DC      X'00008910'      # Offset to PPA1
000010      47F0 F001      000003      BC      R15,1(,R15)      # Wrong Entry Point: cause exception
000014          000003      EQU      *
000014      90EC D00C      000003      STM      R14,R12,12(,R13)      # Save GPRs Used
000018      4110 F024      000003      LA      R1,36(,R15)      # Args for boot strap routine
00001C      98EF F034      000003      LM      R14,R15,52(,R15)      #
000020      07FF          000003      BR      R15      # Branch to boot strap routine
000022      0000          000003      DC      X'0000'      # Available half-word
000024          000003      EQU      *      # Boot Strap Info Block
000024      0000 0000      000003      DC      X'00000000'      # address of entry label
000028      0000 0000      000003      DC      X'00000000'      # WSA24 allocation size
00002C      0000 8A0C      000003      DC      X'00008A0C'      # address of Saved Option String
000030      0000 8948      000003      DC      X'00008948'      # address of entry point name
000034      0000 0054      000003      DC      X'00000054'      # A(Label L3283)
000038      0000 0000      000003      DC      X'00000000'      # address of boot strap routine(IGZXBST)
00003C          000003      EQU      *      # CEE Parameter Block
00003C      0000 0024      000003      DC      X'00000024'      # address of infoBlockLabel

```

```

000040 0000 8A1C      000003      DC      X'00008A1C'      # A(PARMCEE-CEEPPARMBlock)
000044      EQU      *      # Handle growing stack
000044 58F0 C31C      000003      L      R15,796(,R12) # Load CEECAOGETS
000048 184E      000003      LR      R4,R14      # Required NAB
00004A 05EF      000003      BALR   R14,R15     # Extend Stack
00004C 0000 0000      000003      DC      X'00000000'  # Argument list size = 0
000050 A7F4 0009      000003      J      L3281      # Branch back
000054      @MAINENT DS      0H      # PRIMARY ENTRY POINT ADDRESS
000054      EQU      *      # User Code Entry Point
000054 18EF      000003      LR      R14,R15     # Load NAB
000056 4100 E978      000003      LA     R0,2424(,R14) # New NAB Address
00005A 5500 C314      000003      CL     R0,788(,R12) # Exceed current storage segment?
00005E A724 FFF3      000003      JH     L3280      # Yes: branch to recovery code
000062      EQU      *      # Stack now has sufficient room
000062 5000 E04C      000003      ST     R0,76(,R14) # Update NAB
000066 A708 0010      000003      LHI   R0,16      # COBOL Language Word upper half
00006A 0900 0010      000003      SLL   R0,16      # shift to upper half of register
00006E A70A 0301      000003      AHI   R0,769     # add COBOL Language Word lower half
000072 5000 E000      000003      ST     R0,0(,R14) # Save Language Word
000076 50D0 E004      000003      ST     R13,4(,R14) # Save Back Chain
00007A 18DE      000003      LR     R13,R14    # Set new DSA
00007C 4100 D6D0      000003      LA     R0,1744(,R13) # Address of COBDSACB
000080 5000 D074      000003      ST     R0,116(,R13) # Saved in member slot1
000084 4100 0000      000003      LA     R0,0(,R0)  #
000088 5000 D070      000003      ST     R0,112(,R13) # zero member slot0

```

- (1) Offset from the start of the COBOL program
- (2) Hexadecimal representation of assembler instructions
- (3) Source line number
- (4) Pseudo-assembler representation of the code generated for the COBOL program
- (5) Comments that explain the pseudo-assembler code

RELATED REFERENCES

“Signature information bytes” on page 406

Example: MD5 signature

The following example shows LIST output about the MD5 signature. This information is also included in the DWARF debugging data in the application module. MD5 signature is located at 16 bytes before the Timestamp and Version Information section.

```

000608 AAEE 60C2 DAA3      =X'AAEE60C2DAA3'  md5 signature
00060E 776D AEB5 E753      =X'776DAEB5E753'  md5 signature
000614 E767 C4E1      =X'E767C4E1'      md5 signature

```

Note: The MD5 signature is shown only if the TEST option is specified or if -g is specified with **cob2** under z/OS UNIX.

The presence or absence of the MD5 signature is indicated by a compilation flag bit of the PPA2. If the bit is set to 1, the MD5 signature is present; if the bit is set to 0, the MD5 signature is absent. For details about PPA2, see *z/OS Language Environment Vendor Interfaces*.

RELATED REFERENCES

“Example: Program prolog areas” on page 416

Example: Timestamp and version information

The following example shows LIST output about the version of the compiler and the data and time of compilation.

```

                                Timestamp and Version Information
0029C8 F2F0 F1F3      =C'2013'          Compiled Year
0029CC F0F3 F2F7      =C'0327'          Compiled Date MMDD
0029D0 F1F2 F3F1 F2F2      =C'123122'        Compiled Time HHMMSS
0029D6 F0F5 F0F1 F0F0      =C'050100'        VERSION/RELEASE/MOD LEVEL OF PROD
                                Timestamp and Version End

```

Example: Compiler options and program information

The following example shows LIST output for the compiler options and program information.

(1)	(2)	(3)	(4)	(5)
			Compiler Options and Program Information Section	
0029DC		0030	=X'0030'	Size of Compiler Options and Prog Info Section
0029DE	(+00)	0474	=X'0474'	UNSIGNED BINARY CODE PAGE CCSID VALUE
0029E0	(+02)	06	=X'06'	ARCHITECTURE LEVEL
0029E1	(+03)	00	=X'00'	OPTIMIZATION LEVEL
0029E2	(+04)	1406	=X'1406'	INFO. BYTES 28-29
0029E4	(+06)	0000	=X'0000'	RESERVED
0029E6	(+08)	A04875CC2001	=X'A04875CC2001'	INFO. BYTES 1-6
0029EC	(+14)	100010884909	=X'100010884909'	INFO. BYTES 7-12
0029F2	(+20)	002008800C00	=X'002008800C00'	INFO. BYTES 13-18
0029F8	(+26)	000001A000	=X'000001A000'	INFO. BYTES 19-23
0029FD	(+31)	00	=X'00'	COBOL SIGNATURE LEVEL
0029FE	(+32)	0000002F	=X'0000002F'	# DATA DIVISION STATEMENTS
002A02	(+36)	0000005B	=X'0000005B'	# PROCEDURE DIVISION STATEMENTS
002A06	(+40)	18808008	=X'18808008'	INFO. BYTES 24-27
002A0A	(+44)	4040404040404040	=C'	USER LEVEL INFO (LVLINFO)
			Compiler Options and Program Information Section End	

- (1) Offset in the program object
- (2) Offset in decimal
- (3) Contents of the bytes in hexadecimal format
- (4) Assembler representation of the bytes
- (5) Explanation of the bytes in the section

Example: assembler code generated from source code

The following example shows a listing of the assembler code that is generated from source code when you use the LIST compiler option. You can use this listing to find the COBOL verb that corresponds to the instruction that failed.

000964:		display "PROGRAM IGYTCARA - Beginning".			(1)
	(2)	(3)	(4)	(5)	(6)
0001EA	E320 3394 0171	000964	LAY R2,5012(,R3)	#	
0001F0	D203 D5E8 2000	000964	MVC 1512(4,R13),0(R2)	#	\$_CONSTANT_AREA+5012
0001F6	E320 3398 0171	000964	LAY R2,5016(,R3)	#	
0001FC	D203 D5EC 2000	000964	MVC 1516(4,R13),0(R2)	#	\$_CONSTANT_AREA+5016
000202	4120 39C8	000964	LA R2,2504(,R3)	#	
000206	5020 D5F0	000964	ST R2,1520(,R13)	#	
00020A	E320 338C 0171	000964	LAY R2,5004(,R3)	#	
000210	D203 D5F4 2000	000964	MVC 1524(4,R13),0(R2)	#	\$_CONSTANT_AREA+5004
000216	E320 339C 0171	000964	LAY R2,5020(,R3)	#	
00021C	D203 D5F8 2000	000964	MVC 1528(4,R13),0(R2)	#	\$_CONSTANT_AREA+5020
000222	D703 D5FC D5FC	000964	XC 1532(4,R13),1532(R13)	#	
000228	4110 D5E8	000964	LA R1,1512(,R13)	#	_ArgumentList
00022C	E3F0 31D4 0158	000964	LY R15,4564(,R3)	#	_ACON
000232	58C0 D080	000964	L R12,128(,R13)	#	@CAA
000236	0DEF	000964	BASR R14,R15	#	Call "IGZXDSP"
000965:		perform 050-create-vsam-master-file.			
000238	5820 D670	000965	L R2,1648(,R13)	#	VN_ce11
00023C	5020 D544	000965	ST R2,1348(,R13)	#	PfmSv_Cell
000240	C020 0000 0007	000965	LARL R2	#	
000246	5020 D670	000965	ST R2,1648(,R13)	#	VN_ce11
00024A	A7F4 02F4	000965	J 050-CREATE-VSAM-MASTER-FILE	#	
00024E	5820 D544	000965	L R2,1348(,R13)	#	PfmSv_Cell
000252	5020 D670	000965	ST R2,1648(,R13)	#	VN_ce11

- (1) Source code interspersed with the pseudo-assembler instructions
- (2) Relative location of the object code instruction in the module, in hexadecimal notation
- (3) Object code instructions, in hexadecimal notation
The first two or four hexadecimal digits are the instruction, and the remaining digits are the instruction operands. Some instructions have two operands.
- (4) Source line number associated with this assembler code
- (5) Object code instructions, in compiler-generated pseudo assembler
- (6) Explanation of the instruction and the operands used by the instructions

RELATED REFERENCES

“Symbols used in LIST and MAP output” on page 404

Example: Program prolog areas

The following example shows LIST output for the program prolog area. The Program Prologue Area (PPA) is comprised of several sections that contain information about the compiled program.

There is a PPA1 for every procedure in your program, including procedures generated by the compiler. The offset to its corresponding PPA1 is recorded at offset 12 (X'C') from the start of each procedure. The PPA1 contains information about the procedure as well as offsets to the PPA2 and PPA3 sections.

For details on how to use the program prolog areas to locate information in the listing file, see *z/OS Language Environment Vendor Interfaces*.

DATA VALIDATION AND UPDATE PROGRAM IGYTCARA Date 03/30/2013 Time 10:48:16

1	2	3	4
	PPA1: Entry Point Constants		
0081E0	1CCEA506	=F'483304710'	Flags
0081E4	00008310	=A(PPA2-IGYTCARA)	
0081E8	00008378	=A(PPA3-IGYTCARA)	
0081EC	00000000	=F'0'	No EPD
0081F0	FFFE0000	=F'-131072'	Register Save Mask
0081F4	40000000	=F'1073741824'	Member Flags
0081F8	90	=AL1(144)	Flags
0081F9	000978	=AL3(2424)	Calllee's DSA use/8
0081FC	0000	=AL1(0)	Flags
0081FE	0012	=H'18'	Offset/2 to CDL
008200	D0006D00	=F'-805304624'	State variable location
008204	00000000	=F'0'	CDL function length/2
008208	00000000	=F'0'	CDL function EP offset
00820C	00000000	=F'0'	CDL prolog
008210	00000000	=F'0'	CDL epilog
008214	00000000	=F'0'	CDL end
008218	0008 ****	AL2(8),C'IGYTCARA'	
	PPA1 End		

There is one PPA2 for each program. The offset to the PPA2 is recorded in each PPA1. The PPA2 contains offsets to the Time Stamp and Version Information section of the listing as well as to the PPA4 section.

If the TEST option is not in effect, the PPA2 section looks like this:

	PPA2: Entry Point Constants		
000800	04002203	=F'67117571'	Flags
000804	FFFFFF800	=A(CEESTART-PPA2)	
000808	00000058	=F'88'	A(PPA4-PPA2)
00080C	FFFFFFFB0	=A(TIMESTAMP-PPA2)	
000810	FFFFFF800	=A(PrimaryEntryPoint-PPA2)	
000814	02200000	=F'35651584'	Flags
	PPA2 End		

If the TEST option is in effect, the PPA2 section looks like this:

	PPA2: Entry Point Constants		
000830	04002203	=F'67117571'	Flags
000834	FFFFFF7D0	=A(CEESTART-PPA2)	
000838	00000058	=F'88'	A(PPA4-PPA2)
00083C	FFFFFFFB0	=A(TIMESTAMP-PPA2)	
000840	FFFFFF7D0	=A(PrimaryEntryPoint-PPA2)	
000844	02600000	=F'39845888'	Flags
	PPA2 End		

There is one PPA3 for each program (including each nested program) in a COBOL source file. Each entry contains offsets, relative to the PPA3 itself, to the base locator table and to the special register table. The PPA3 also contains an offset from the start of the program to the first COBOL statement.

	PPA3: Entry Point Constants		
001408	00000000	=F'0'	Flags
00140C	000000C0	=F'192'	A(Base_Locator_Table-PPA3)
001410	000000D8	=F'216'	A(Special_Register_Table-PPA3)
001414	00000184	=X'184'	A(User_Entry-CUEntry)
	PPA3 End		

There is one PPA4 for each program. It has offsets to various compiler generated tables, such as the writable static area (the Static Map and WSA24 sections). The offset to the PPA4 is recorded in a field of the PPA2.

	PPA4: Entry Point Constants		
008340	08000000	=F'134217728'	Flags 1
008344	00020100	=F'131328'	Flags 2
008348	00000000	=F'0'	A(NORENTstatic)

```

00834C 00000000      =F'0'          Q(RENTstatic)
008350 00000000      =F'0'          A(DATA24_address_cell-RENTstatic)
008354 FFFF7CC0      =F'-33600'     A(Code-PPA4)
008358 00008398      =F'33688'     Code Length
00835C 00000000      =F'0'          Length NORENTstatic
008360 00002204      =F'8708'      Length RE NTstatic
008364 00000000      =F'0'          Length DATA24
008368 002A          =X'2A'        A(CUName-PPA4)
008372 00000090      =X'90'        Offset UsrWrkStrg
008376 0000000B      =X'B'         Length UsrWrkStrg
00837A 00           =X'0'         Has Externals

```

PPA4 End

- 1 Relative location, in hexadecimal format, of the PPA field in the object module
- 2 The contents of the field, in hexadecimal
- 3 An assembler-like syntax defining the field
- 4 A description of the contents of the field.

RELATED REFERENCES

z/OS Language Environment Vendor Interfaces

Example: Static map

The following example shows LIST output about the writable static area.

The STATIC MAP contains the level-1 symbols defined in the WORKING-STORAGE part of the program. If compiled with the RENT option, the first column contains the offset of the level-1 symbol from the start of the Working Storage Area (WSA) for the program. For NORENT compilations, the offset is the start of the level-1 from a block of storage allocated by the compiler. The starting address of this block resides in the Constant Area. The second column is the size of the symbol, including all of its sub-level members. The third column is the name.

```

          * * * * * S T A T I C   M A P   * * * * *
OFFSET (HEX)  LENGTH (HEX)  NAME
          0             14    BLF_Ptrs
          14             C     BLT_Ptrs
          20             4     JNIENVPTR
          28             2     RETURN-CODE
          30             2     SORT-RETURN
          38             8     SORT-CONTROL
          40             4     SORT-CORE-SIZE
          48             4     SORT-FILE-SIZE
          50             4     SORT-MODE-SIZE
          58             8     SORT-MESSAGE
          60             4     TALLY
          68             1     SHIFT-OUT
          70             1     SHIFT-IN
          78             4     XML-CODE
          80             1E    XML-EVENT
          A0             4     XML-INFORMATION
          A8             50    COMMUTER-FILE
          F8             50    COMMUTER-FILE-MST
          148            7A    PRINT-FILE
          1C8            1     WORKING-STORAGE-FOR-IGYCARA
          1D0            2     COMP-CODE
          1D8            3     WS-TYPE
          1E0            2     I-F-STATUS-AREA
          1E8            8     STATUS-AREA
          1F0            2     UPDATE-FILE-STATUS
          1F8            2     LOCCODE-FILE-STATUS
          200            2     UPDPRINT-FILE-STATUS
          208            3     FLAGS

```

If you compile with the compiler option DATA(24), a WSA 24 Map is generated. It shows the names of the symbols that are mapped below the 16 MB line. The symbols in the WORKING-STORAGE area in the source are mapped into the writable static area which is shown in the Static Map.

* * * * * W S A 2 4 M A P * * * * *

OFFSET (HEX)	LENGTH (HEX)	NAME
0	4	JNIENVPTR
8	2	RETURN-CODE
10	2	SORT-RETURN
18	8	SORT-CONTROL
20	4	SORT-CORE-SIZE
28	4	SORT-FILE-SIZE
30	4	SORT-MODE-SIZE
38	8	SORT-MESSAGE
40	4	TALLY
48	1	SHIFT-OUT
50	1	SHIFT-IN
58	4	XML-CODE
60	1E	XML-EVENT
80	4	XML-INFORMATION
88	50	COMMUTER-FILE
D8	50	COMMUTER-FILE-MST
128	7A	PRINT-FILE
1A8	1	WORKING-STORAGE-FOR-IGYCARA
1B0	2	COMP-CODE
1B8	3	WS-TYPE
1C0	2	I-F-STATUS-AREA
1C8	8	STATUS-AREA
1D0	2	UPDATE-FILE-STATUS

Example: Constant area

The following example shows LIST output about strings and other literals from the COBOL source as well as those generated by the compiler.

The compiler generates loads from (and stores to) the Constant Area by loading the starting address of Constant Area and adding the fixed offsets to the respective constants or literals.

(1)	(2)	CONSTANT AREA:	(3)	(4)
006A98 (+0)	00CCDDFF	00000000	C9C7E8E3 C3C1D9C1	00000000 00000000 C9C7E9E2 D9E3C3C4
006ABB (+32)	40000A00	40000000	00000008 00000000	E2E8E2D6 E4E34040 00100000 00000000
006ADB (+64)	0E000000	00000001	0F000000 0000001E	00000000 40000000 00000003 0064003C
006AF8 (+96)	000FE800	9F0F0000	00000011 00000000	E3D9C1D5 E2C1C3E3 4B40C3D6 C4C50000
006B18 (+128)	0000000E	00000000	E2C8C9C6 E340C3D6	C4C54040 40400000 C8D6D4C5 40D3D6C3
006B38 (+160)	4B40C3D6	C4C50000	E6D6D9D2 40D3D6C3	4B40C3D6 C4C50000 D3C1E2E3 40D5C1D4
006B58 (+192)	C5404040	40400000	C9D5C9E3 C9C1D3E2	40404040 40400000 C4E4D7D3 C9C3C1E3
006B78 (+224)	C540D9C5	C34B0000	D9C5C34B 40D5D6E3	40C6D6E4 D5C40000 C1C4C4D9 C5E2E240
006B98 (+256)	40404040	40400000	C3C9E3E8 40404040	40404040 40400000 E2E3C1E3 C540C3D6
006BB8 (+288)	C4C54040	40400000	E9C9D7C3 D6C4C540	40404040 40400000 C8D6D4C5 40D7C8D6
006BD8 (+320)	D5C54040	40400000	E6D6D9D2 40D7C8D6	D5C54040 40400000 C8D6D4C5 40D1E4D5
006BF8 (+352)	C3E3C9D6	D5400000	E6D6D9D2 40D1E4D5	C3E3C9D6 D5400000 C4D9C9E5 C9D5C740
006C18 (+384)	E2E3C1E3	E4E20000	40D9C5D7 D6D9E340	407B7A40 C9C7E8E3 C3C1D9C1 40404040
006C38 (+416)	40404040	40404040	40404040 40404040	40404040 40404040 40404000 00000033
006C58 (+448)	C3D6D4D4	E4E3C5D9	40C6C9D3 C540E4D7	C4C1E3C5 40D3C9E2 E3404040 40404040
006C78 (+480)	40404040	40404040	40404040 40404040	40400000 00000032 40404040 40404040
006C98 (+512)	D7C1C7C5	407B7A40	00000000 00000010	40D7D9D6 C7D9C1D4 407B7A40 C9C7E8E3
006CB8 (+544)	C3C1D9C1	40404040	404040D9 E4D540E3	C9D4C57A 40000000 00000025 7A000000
006CD8 (+576)	00000030	00000000	D9E4D540 C4C1E3C5	7A400000 0000000A 61000000 00000008

- (1) Offset in csect.
- (2) Offset in base 10.
- (3) 8 columns containing the bytes in the Constant Area
- (4) Character representation. A dot (.) is used for non-printable characters.

Example: Base locator table

The following example shows LIST output for the base locator table.

```

Base Locator Table
008AB0 01          =X'1'          Table Version
008AB1 00          =X'0'          Reserved
008AB2 0008       =H'8'          Header length
008AB4 00000010   =F'16'         Array byte length
008AB8 2A00       =X'2A00'       Flags & info (element 1)
008ABA 00000014   =X'14'         Offset to cells
008ABE 03         =X'3'          Cell count
008ABF 0A00       =X'A00'        Flags & info (element 2)
008AC1 00000000   =X'0'          Offset to cells
008AC5 05         =X'5'          Cell count
008AC6 0000       =X'0'          Flags & info (end of array)
Base Locator Table End

```

For more information about the base locator table, see *z/OS Language Environment Vendor Interfaces*.

RELATED REFERENCES

z/OS Language Environment Vendor Interfaces (Base locator table)

Example: special register table

The following example shows LIST output for the special register table. The special register table has a similar format to the base locator table.

```

Special Register Table
0015B0 01          =X'1'          Table Version
0015B1 00          =X'0'          Reserved
0015B2 0008       =H'8'          Header length
0015B4 00000006   =F'6'          Array byte length
0015B8 12         =X'12'         Flags & info (element 1)
0015B9 00000018   =X'18'         Offset to cells
0015BD 00         =X'0'          Flags & info (end of array)
Special Register Table End

```

Each entry in the special register table consists of the following items:

- A byte which represents the following information:
 - Special register ID number (bits 0 - 4). ID = 1 represents the RETURN-CODE register
 - Access mode (bits 5 - 8)
 - MODE = 0; Base Address = Top of Stack
 - MODE = 1; Base Addr = NORENT Static
 - MODE = 2; Base Addr = 32-bit RENT static
 - MODE = 3; 24-bit NORENT static
- An offset to the special register

The end of the special register table is indicated by a null byte.

Example: External symbols

The following example shows LIST output for external symbols defined by, or referred to in your program. The external symbol dictionary contains one entry per external symbol defined by or referred to in the program.

Each entry contains the address, length and symbol type. Symbol types are:

ED External Definition
SD Section Definition
LD Label Definition
ER External Reference
PR Pseudo Register

```

E X T E R N A L   S Y M B O L   D I C T I O N A R Y
TYPE  ID  ADDR  LENGTH  NAME

```

SD	1	000000	000000	IGYTCARA
ED	2	000000	000000	C_CEESG003
ED	3	000000	008AC8	C_CODE
LD	4	000000	000000	IGYTCARA#C
ER	5	000000	000000	CEESTART
ER	6	000000	000000	CEEBETBL
ED	7	000000	000000	C_WSA
PR	8	000000	002204	IGYTCARA#S
ED	9	000000	000022	B_IDRL
ER	10	000000	000000	IGZXBST
ER	11	000000	000000	IGYTCARA
ER	12	000000	000000	IGZXPRS
ER	13	000000	000000	IGZXCMSG
ER	14	000000	000000	IGZXDSP
ER	15	000000	000000	IGZ XVCLS

Example: DSA memory map (Automatic map)

The following example shows LIST output for the dynamic save area (DSA). The DSA contains information about the contents of the storage acquired when a separately compiled procedure is entered.

```

* * * * *  A U T O M A T I C  M A P  * * * * *
      1          2          3
  OFFSET (HEX)  LENGTH (HEX)  NAME
Block name: IGYTCARA

      80          4          _CAA
      C8          3          _BEtemp200
      CC          3          _BEtemp204
      D0          3          _BEtemp208
      D4          3          _BEtemp212
      D8          3          _BEtemp216
      DC          3          _BEtemp220
      E0          3          _BEtemp224
      E4          3          _BEtemp228
      E8          10         _BEtemp232
      F8          20         _BEtemp248
     118          20         _BEtemp280
     138          4          _BEtemp312
     13C          4          _BEtemp316
     140          4          _BEtemp320
     144          4          _BEtemp324
     148          4          _BEtemp328
     14C          4          _BEtemp332
     150          4          _BEtemp336
     154          4          _BEtemp340
     158          4          _BEtemp344
     15C          4          _BEtemp348
     160          4          _BEtemp352
     164          4          _BEtemp356
     168          4          _BEtemp360
     16C          4          _BEtemp364
     170          4          _BEtemp368
     174          4          _BEtemp372
     178          4          _BEtemp376

```

- (1) Hexadecimal offset of the DSA field from the start of the DSA
- (2) Length (in hexadecimal) of the DSA field
- (3) Symbol name

Example: XREF output: data-name cross-references

The following example shows a sorted cross-reference of data-names that is produced by the XREF compiler option. Numbers in parentheses refer to notes after the example.

An "M" preceding a data-name reference indicates that the data-name is modified by this reference.

(1)	(2)	(3)
Defined	Cross-reference of data-names	References
265	ABEND-ITEM1	
266	ABEND-ITEM2	
347	ADD-CODE	1102 1162
381	ADDRESS-ERROR.	M1126
280	AREA-CODE.	1236 1261 1324 1345
382	CITY-ERROR	M1129

(4)

Context usage is indicated by the letter preceding a procedure-name reference. These letters and their meanings are:

- A = ALTER (procedure-name)
- D = GO TO (procedure-name) DEPENDING ON
- E = End of range of (PERFORM) through (procedure-name)
- G = GO TO (procedure-name)
- P = PERFORM (procedure-name)
- T = (ALTER) TO PROCEED TO (procedure-name)
- U = USE FOR DEBUGGING (procedure-name)

(5)	(6)	(7)
Defined	Cross-reference of procedures	References
877	000-DO-MAIN-LOGIC	
930	050-CREATE-STL-MASTER-FILE . .	P879
982	100-INITIALIZE-PARAGRAPH . . .	P880
1441	1100-PRINT-I-F-HEADINGS. . . .	P915
1481	1200-PRINT-I-F-DATA.	P916
1543	1210-GET-MILES-TIME.	P1510
1636	1220-STORE-MILES-TIME.	P1511
1652	1230-PRINT-SUB-I-F-DATA. . . .	P1532
1676	1240-COMPUTE-SUMMARY	P1533
1050	200-EDIT-UPDATE-TRANSACTION. .	P886
1124	210-EDIT-THE-REST.	P1116
1159	300-UPDATE-COMMUTER-RECORD . .	P888
1207	310-FORMAT-COMMUTER-RECORD . .	P1164 P1179
1258	320-PRINT-COMMUTER-RECORD. . .	P1165 P1176 P1182 P1192
1288	330-PRINT-REPORT	P1178 P1202 P1256 P1280 P1340 P1365 P1369
1312	400-PRINT-TRANSACTION-ERRORS .	P890

Cross-reference of data-names:

- (1) Line number where the name was defined.
- (2) Data-name.
- (3) Line numbers where the name was used. If M precedes the line number, the data item was explicitly modified at the location.

Cross-reference of procedure references:

- (4) Explanations of the context usage codes for procedure references.
- (5) Line number where the procedure-name is defined.
- (6) Procedure-name.
- (7) Line numbers where the procedure is referenced, and the context usage code for the procedure.

"Example: XREF output: program-name cross-references" on page 422

"Example: XREF output: COPY/BASIS cross-references" on page 422

"Example: XREF output: embedded cross-reference" on page 423

Example: XREF output: program-name cross-references

The following example shows a sorted cross-reference of program-names produced by the XREF compiler option. Numbers in parentheses refer to notes that follow the example.

(1) Defined	(2) Cross-reference of programs	(3) References
EXTERNAL	EXTERNAL1.	25
2	X.	41
12	X1	33 7
20	X11.	25 16
27	X12.	32 17
35	X2	40 8

- (1) Line number where the program-name was defined. If the program is external, the word EXTERNAL is displayed instead of a definition line number.
- (2) Program-name.
- (3) Line numbers where the program is referenced.

Example: XREF output: COPY/BASIS cross-references

The following example shows a sorted cross-reference of copybooks to the library-names and data-set names of the associated copybooks, produced by the XREF compiler option under z/OS. Numbers in parentheses refer to notes after the example.

COPY/BASIS cross-reference of text-names, library names

(1) Text-name (Member)	(1) Library (DDNAME)	(2) File name (Data set name)	(3) Concat Level	(4) ISPF Created
ACTIONS	OTHERLIB	USERID.COBOL.COPY	0	1992/07/11
ACTIONS	SYSLIB	USERID.COBOL.COPY	0	1992/07/11
CUSTOMER	ALTDDXXY	USERID.COBOL.LIB3	0	2007/06/01
CUSTOMER	SYSLIB	USERID.COBOL.LIB2PDSE	1	2007/06/07
HOUSE	ALTDDXXY	USERID.COBOL.LIB2	1	2007/06/07
HOUSE	SYSLIB	USERID.COBOL.LIB2PDSE	1	
IMOTOR	SYSLIB	USERID.COBOL.LIB4X	3	2007/06/07
ISOVERFY	SYSLIB	USERID.COBOL.COPY	0	
NSMAP	SYSLIB	USERID.COBOL.LIB3	2	

- (1) Text-name and library (an abbreviation for library-name) are from the statement COPY *text-name* OF *library-name* in the source, for example, Copy ACTIONS OF OTHERLIB.
- (2) The name of the data set from which the COPY member was copied.
- (3) Abbreviation for concatenation level. Indicates how many levels deep a given data set is from the first data set in the concatenation for a given ddname.

For example, four data sets in the example above are concatenated to ddname SYSLIB:

DDNAME	DSNAME	(concatenation level)
SYSLIB DD	DSN=USERID.COBOL.COPY,	0
DD	DSN=USERID.COBOL.LIB2PDSE,	1
DD	DSN=USERID.COBOL.LIB3,	2
DD	DSN=USERID.COBOL.LIB4X	3

Thus for example member NSMAP shown in the listing above was found in data set USERID.COBOLE.LIB3, which is two levels down from the first data set in the SYSLIB concatenation.

- (4) Creation date is shown if the PDS or PDSE was edited with STATS ON in ISPF.

Tip: Under z/OS, if there is more than one data set in your SYSLIB concatenation, the COPY/BASIS cross-reference might in some cases be incomplete or missing. For details, see the related reference about the XREF compiler option.

If you compile in the z/OS UNIX shell, the cross-reference looks like the excerpt shown below.

COPY/BASIS cross-reference of text-names, library names, and file names

(5) Text-name	(5) Library-name	(6) File name
'/copydir/copyM.cb1'	SYSLIB	/u/JSMITH/cobol//copydir/copyM.cb1
'/copyA.cpy'	SYSLIB	/u/JSMITH/cobol//copyA.cpy
'cobol/copyA.cpy'	ALTDD2	/u/JSMITH/cobol/copyA.cpy
'copy/stuff.cpy'	ALTDD2	/u/JSMITH/copy/stuff.cpy
'copydir/copyM.cb1'	SYSLIB	/u/JSMITH/cobol/copydir/copyM.cb1
'copydir/copyM.cb1'	SYSLIB (default)	/u/JSMITH/cobol/copydir/copyM.cb1
'stuff.cpy'	ALTDD	/u/JSMITH/copy/stuff.cpy
"copyA.cpy"	(7) SYSLIB (default)	/u/JSMITH/cobol/copyA.cpy
"reallyXXVeryLongLon>	SYSLIB (default)	(8)<JSMITH/cobol/reallyXXVeryLongLongName.cpy
OTHERDD	ALTDD2	/u/JSMITH//copy/other.cob
. . .		

Note: Some names were truncated. > = truncated on right < = truncated on left

- (5) From the COPY statement in the source; for example the COPY statement corresponding to the third item in the cross-reference above would be:
COPY 'cobol/copyA.cpy' Of ALTDD2
- (6) The fully qualified path of the file from which the COPY member was copied
- (7) Truncation of a long text-name or library-name on the right is marked by a greater-than sign (>).
- (8) Truncation of a long file name on the left is marked by a less-than sign (<).

RELATED REFERENCES
"XREF" on page 374

Example: XREF output: embedded cross-reference

The following example shows a modified cross-reference that is embedded in the source listing. The cross-reference is produced by the XREF compiler option.

LineID	PL	SL	-----*A-1-B--*-----2-----3-----4-----5-----6-----7- --*-----8	Map and Cross Reference
000878			procedure division.	
000879			000-do-main-logic.	
000880			display "PROGRAM IGYTCARA - Beginning".	
000881			perform 050-create-vsam-master-file.	932 (1)
000882			perform 100-initialize-paragraph.	984
000883			read update-transaction-file into ws-transaction-record	204 340
000884			at end	
000885	1		set transaction-eof to true	254
000886			end-read.	
000984			100-initialize-paragraph.	
000985			move spaces to ws-transaction-record	IMP 340 (2)
000986			move spaces to ws-commuter-record	IMP 316
000987			move zeroes to commuter-zipcode	IMP 327
000988			move zeroes to commuter-home-phone	IMP 328
000989			move zeroes to commuter-work-phone	IMP 329
000990			move zeroes to commuter-update-date	IMP 333
000991			open input update-transaction-file	204
000992			location-file	193

```

000993          i-o commuter-file          181
000994          output print-file          217
. . .
001442          1100-print-i-f-headings.
001443
001444          open output print-file.    217
001445
001446          move function when-compiled to when-comp.    IFN 698 (2)
001447          move when-comp (5:2) to compile-month.      698 640
001448          move when-comp (7:2) to compile-day.       698 642
001449          move when-comp (3:2) to compile-year.     698 644
001450
001451          move function current-date (5:2) to current-month.    IFN 649
001452          move function current-date (7:2) to current-day.    IFN 651
001453          move function current-date (3:2) to current-year.    IFN 653
001454
001455          write print-record from i-f-header-line-1    222 635
001456          after new-page.                               138
. . .

```

- (1) Line number of the definition of the data-name or procedure-name in the program
- (2) Special definition symbols:
 - UND** The user name is undefined.
 - DUP** The user name is defined more than once.
 - IMP** Implicitly defined name, such as special registers and figurative constants.
 - IFN** Intrinsic function reference.
 - EXT** External reference.
 - *** The program-name is unresolved because the NOCOMPILE option is in effect.

Example: OFFSET compiler output

The following example shows a compiler listing that has a condensed verb listing, global tables, WORKING-STORAGE information, and literals. The listing is output from the OFFSET compiler option.

DATA VALIDATION AND UPDATE PROGRAM IGYTCARA Date 03/30/2013 Time 10:48:16

```

. . .
(1)  (2)  (3)
LINE #  HEXLOC  VERB      LINE #  HEXLOC  VERB      LINE #  HEXLOC  VERB
000880  0026F0  DISPLAY    000881  002702  PERFORM    000933  002702  OPEN
000934  002722  IF         000935  00272C  DISPLAY    000936  002736  PERFORM
001389  002736  DISPLAY    001390  002740  DISPLAY    001391  00274A  DISPLAY
001392  002754  DISPLAY    001393  00275E  DISPLAY    001394  002768  DISPLAY
001395  002772  DISPLAY    000937  00277C  PERFORM    001434  00277C  DISPLAY
001435  002786  STOP       000939  0027A2  MOVE       000940  0027AC  WRITE
000941  0027D6  IF         000942  0027E0  DISPLAY    000943  0027EA  PERFORM
001389  0027EA  DISPLAY    001390  0027F4  DISPLAY    001391  0027FE  DISPLAY
001392  002808  DISPLAY    001393  002812  DISPLAY    001394  00281C  DISPLAY
001395  002826  DISPLAY    000944  002830  DISPLAY    000945  00283A  PERFORM
001403  00283A  DISPLAY    001404  002844  DISPLAY    001405  00284E  DISPLAY
001406  002858  DISPLAY    001407  002862  CALL      000947  002888  CLOSE

```

- (1) Line number. Your line numbers or compiler-generated line numbers are listed.
- (2) Offset, from the start of the program, of the code generated for this verb (in hexadecimal notation).

The verbs are listed in the order in which they occur and are listed once for each time they are used.
- (3) Verb used.

RELATED REFERENCES
"OFFSET" on page 345

Example: VBREF compiler output

The following example shows an alphabetic listing of all the verbs in a program, and shows where each is referenced. The listing is produced by the VBREF compiler option.

(1)	(2)	(3)
2	ACCEPT	1010 1012
2	ADD.	1290 1306
1	CALL	1406
5	CLOSE.	898 945 970 1526 1535
20	COMPUTE.	1506 1640 1644 1657 1660 1663 1664 1665 1678 1682 1686 1691 1696 1701 1709 1713
		1718 1723 1728 1733
2	CONTINUE	1062 1069
2	DELETE	964 1193
48	DISPLAY.	878 906 917 918 919 933 940 942 947 953 960 966 972 996 997 998 999 1003 1006 1037
		1090 1168 1171 1185 1195 1387 1388 1389 1390 1391 1392 1393 1401 1402 1403 1404
		1405 1433 1485 1486 1492 1497 1498 1520 1521 1528 1529 1624
2	EVALUATE	1161 1557
47	IF	887 905 932 939 946 952 959 965 971 993 1002 1036 1051 1054 1071 1074 1077 1089
		1102 1111 1115 1125 1128 1131 1134 1137 1141 1145 1148 1151 1167 1184 1194 1240
		1247 1265 1272 1289 1321 1330 1339 1351 1361 1484 1496 1519 1527
183	MOVE	907 937 957 983 984 985 986 987 988 1004 1011 1013 1025 1038 1052 1055 1060 1067
		1072 1075 1078 1079 1080 1081 1082 1083 1091 1103 1112 1126 1129 1132 1135 1139
		1143 1146 1149 1152 1160 1163 1169 1175 1177 1180 1181 1186 1191 1196 1201 1208
		1209 1210 1211 1212 1213 1214 1215 1216 1217 1218 1219 1220 1221 1222 1229 1230
		1231 1232 1233 1234 1235 1239 1241 1244 1248 1250 1251 1253 1254 1255 1257 1258
		1259 1260 1264 1266 1269 1273 1275 1276 1278 1279 1291 1294 1299 1301 1303 1307
		1313 1314 1315 1316 1317 1318 1319 1320 1322 1323 1327 1328 1331 1333 1334 1336
		1338 1341 1342 1343 1344 1348 1349 1352 1354 1355 1357 1362 1364 1368 1374 1375
		1376 1377 1378 1379 1380 1381 1414 1417 1422 1425 1445 1446 1447 1448 1450 1451
		1452 1457 1464 1489 1502 1507 1508 1509 1517 1551 1561 1566 1571 1576 1581 1586
		1591 1596 1601 1606 1611 1616 1621 1626 1627 1679 1683 1688 1693 1698 1703 1710
		1715 1720 1725 1730 1735
5	OPEN	931 951 989 1443 1483
62	PERFORM.	879 880 885 886 888 890 892 908 909 915 916 934 935 941 943 948 949 954 955 961
		962 967 968 973 974 1000 1005 1008 1023 1039 1092 1093 1116 1164 1165 1170 1172
		1176 1178 1179 1182 1187 1188 1192 1197 1198 1202 1246 1256 1271 1280 1329 1340
		1350 1359 1365 1369 1504 1510 1511 1532 1533
8	READ	881 893 958 1014 1026 1085 1490 1514
1	REWRITE.	1183
4	SEARCH	1058 1065 1413 1421
46	SET.	883 895 1016 1028 1041 1057 1064 1084 1087 1363 1412 1420 1493 1499 1516 1522 1548
		1550 1559 1560 1564 1565 1569 1570 1574 1575 1579 1580 1584 1585 1589 1590 1594
		1595 1599 1600 1604 1605 1609 1610 1614 1615 1619 1620 1639 1643
2	STOP	920 1434
4	STRING	1236 1261 1324 1345
33	WRITE.	938 1166 1292 1293 1295 1296 1297 1298 1300 1302 1305 1454 1459 1462 1465 1467 1469
		1471 1512 1654 1655 1667 1668 1669 1740 1742 1744 1745 1746 1747 1748 1749 1750

- (1) Number of times the verb is used in the program
- (2) Verb
- (3) Line numbers where the verb is used

Part 3. Targeting COBOL programs for certain environments

Chapter 20. Developing COBOL programs for CICS

COBOL programs that are written for CICS can run under CICS Transaction Server. CICS COBOL application programs that use CICS services must use the CICS command-level interface.

When you use the CICS compiler option, the Enterprise COBOL compiler handles both native COBOL statements and embedded CICS statements in the source program. You can still use the separate CICS translator to translate CICS statements to COBOL code, but use of the integrated CICS translator is recommended instead.

After you compile and bind your program, you need to do some other steps such as updating CICS tables before you can run the COBOL program under CICS. However, these CICS topics are beyond the scope of COBOL information. For further information, see the related tasks.

You can determine how runtime errors are handled by setting the CBLPSHPOP runtime option. For information about CICS HANDLE and CBLPSHPOP, see the related tasks.

RELATED CONCEPTS

“Integrated CICS translator” on page 435

RELATED TASKS

“Coding COBOL programs to run under CICS”

“Compiling with the CICS option” on page 433

“Using the separate CICS translator” on page 436

“Handling errors by using CICS HANDLE” on page 438

Language Environment Programming Guide (Condition handling under CICS: using the CBLPSHPOP runtime option)

CICS Application Programming Guide

RELATED REFERENCES

“CICS” on page 312

Coding COBOL programs to run under CICS

To code a program to run under CICS, code CICS commands in the PROCEDURE DIVISION by using the EXEC CICS command format.

```
EXEC CICS command-name command-options  
END-EXEC
```

CICS commands have the basic format shown above. Within EXEC commands, use the space as a word separator; do not use a comma or a semicolon. Do not code COBOL statements within EXEC CICS commands.

Restriction: You cannot run COBOL programs that have object-oriented syntax for Java interoperability in CICS. In addition, if you write programs to run under CICS, do not use the following code:

- FILE-CONTROL entry in the ENVIRONMENT DIVISION, unless the FILE-CONTROL entry is used for a SORT statement

- FILE SECTION of the DATA DIVISION, unless the FILE SECTION is used for a SORT statement
- User-specified parameters to the main program
- USE declaratives (except USE FOR DEBUGGING)
- These COBOL language statements:
 - ACCEPT format 1: data transfer (you can use format-2 ACCEPT to retrieve the system date and time)
 - CLOSE
 - DELETE
 - DISPLAY UPON CONSOLE
 - DISPLAY UPON SYSPUNCH
 - MERGE
 - OPEN
 - READ
 - RERUN
 - REWRITE
 - START
 - STOP *literal*
 - WRITE

If you plan to use the separate CICS translator, you must put any REPLACE statements that contain EXEC commands after the PROCEDURE DIVISION header for the program, otherwise the commands will not be translated.

Coding file input and output: You must use CICS commands for most input and output processing. Therefore, do not describe files or code any OPEN, CLOSE, READ, START, REWRITE, WRITE, or DELETE statements. Instead, use CICS commands to retrieve, update, insert, and delete data.

Coding a COBOL program to run above the 16 MB line: Under Enterprise COBOL, the following restrictions apply when you code a COBOL program to run above the 16 MB line:

- If you use IMS/ESA[®] without DBCTL, DL/I CALL statements are supported only if all the data passed in the call resides below the 16 MB line. Therefore, you must specify the DATA(24) compiler option. However, if you use IMS/ESA with DBCTL, you can use the DATA(31) compiler option instead and pass data that resides above the 16 MB line.
 - If you use EXEC DLI instead of DL/I CALL statements, you can specify DATA(31) regardless of the level of the IMS product.
- If the receiving program is link-edited with AMODE 31, addresses that are passed must be 31 bits long, or 24 bits long with the leftmost byte set to zeros.
- If the receiving program is link-edited with AMODE 24, addresses that are passed must be 24 bits long.

Displaying the contents of data items: DISPLAY to the system logical output device (SYSOUT, SYSLIST, SYSLST) is supported under CICS. The DISPLAY output is written to the Language Environment message file (transient data queue CESE). DISPLAY . . . UPON CONSOLE and DISPLAY . . . UPON SYSPUNCH, however, are not allowed. You can specify the DISPSIGN option to control output formatting for DISPLAY of signed numeric items.

RELATED CONCEPTS

“Integrated CICS translator” on page 435

RELATED TASKS

“Sorting under CICS” on page 237

“Getting the system date under CICS”

“Calling to or from COBOL programs”

“Determining the success of ECI calls” on page 433

“Using the separate CICS translator” on page 436

RELATED REFERENCES

“CICS SORT application restrictions” on page 237

“DISPSIGN” on page 320

Getting the system date under CICS

To retrieve the system date in a CICS program, use a format-2 ACCEPT statement or the CURRENT-DATE intrinsic function.

You can use any of these format-2 ACCEPT statements in CICS to get the system date:

- ACCEPT *identifier-2* FROM DATE (two-digit year)
- ACCEPT *identifier-2* FROM DATE YYYYMMDD
- ACCEPT *identifier-2* FROM DAY (two-digit year)
- ACCEPT *identifier-2* FROM DAY YYYYDDD
- ACCEPT *identifier-2* FROM DAY-OF-WEEK (one-digit integer, where 1 represents Monday)

You can use this format-2 ACCEPT statement in CICS to get the system time:

- ACCEPT *identifier-2* FROM TIME

Alternatively, you can use the CURRENT-DATE intrinsic function, which can also provide the time.

These methods work in both CICS and non-CICS environments.

Do not use a format-1 ACCEPT statement in a CICS program.

RELATED TASKS

“Assigning input from a screen or file (ACCEPT)” on page 34

RELATED REFERENCES

CURRENT-DATE (*Enterprise COBOL Language Reference*)

Calling to or from COBOL programs

You can make calls to or from VS COBOL II, COBOL for MVS & VM, COBOL for OS/390 & VM, and Enterprise COBOL programs by using the CALL statement.

If you are calling a separately compiled COBOL program that was processed with either the separate CICS translator or the integrated CICS translator, you must pass DFHEIBLK and DFHCOMMAREA as the first two parameters in the CALL statement.

Called programs that are processed by the separate CICS translator or the integrated CICS translator can contain any function that is supported by CICS for the language.

Dynamic calls:

You can use COBOL dynamic calls when running under CICS. If a COBOL program contains EXEC CICS statements or contains EXEC SQL statements, the NODYNAM compiler option is required. To dynamically call a program in this case, you can use CALL *identifier* with the NODYNAM compiler option.

If a COBOL program contains no EXEC CICS statements and contains no EXEC SQL statements, there is no requirement to compile with NODYNAM. To dynamically call a program in this case, you can use either CALL *literal* with the DYNAM compiler option, or CALL *identifier*.

Note: END-EXEC cannot be followed by a period when it is associated with EXEC CICS statements even though it is required for EXEC SQL statements.

You must define dynamically called programs in the CICS program processing table (PPT) if you are not using CICS autoinstall. Under CICS, COBOL programs do not support dynamic calls to subprograms that have the RELOAD=YES option coded in their CICS PROGRAM definition. Dynamic calls to programs that are defined with RELOAD=YES can cause a storage shortage. Use the RELOAD=NO option for programs that are to be dynamically called by COBOL.

Interlanguage communication (ILC):

Support for ILC with other high-level languages is available. Where ILC is not supported, you can use CICS LINK, XCTL, and RETURN instead.

The following table shows the calling relationship between COBOL and assembler programs. In the table, assembler programs that conform to the interface that is described in the *Language Environment Programming Guide* are called *Language Environment-conforming* assembler programs. Those that do not conform to the interface are *non-Language Environment-conforming* assembler programs.

Table 55. Calls between COBOL and assembler under CICS

Calls between COBOL and assembler programs	Language Environment-conforming assembler program	Non-Language Environment-conforming assembler program
From an Enterprise COBOL program to the assembler program?	Yes	Yes
From the assembler program to an Enterprise COBOL program?	Yes	No

Nested programs:

When you compile with the integrated CICS translator, the translator generates the DFHEIBLK and DFHCOMMAREA control blocks with the GLOBAL clause in the outermost program. Therefore if you code nested programs, you do not have to pass these control blocks as arguments on calls to the nested programs.

If you code nested programs and you plan to use the separate CICS translator, pass DFHEIBLK and DFHCOMMAREA as parameters to the nested programs that contain EXEC commands or references to the EXEC interface block (EIB). You must pass the same parameters also to any program that forms part of the control hierarchy between such a program and its top-level program.

RELATED CONCEPTS

“Integrated CICS translator” on page 435

RELATED TASKS

“Using the separate CICS translator” on page 436

“Choosing the DYNAM or NODYNAM compiler option” on page 451

“Handling errors when calling programs” on page 250

Language Environment Writing ILC Communication Applications (ILC under CICS)

CICS External Interfaces Guide

Language Environment Programming Guide

RELATED REFERENCES

“DYNAM” on page 323

Determining the success of ECI calls

After calls to the external CICS interface (ECI), the content of the RETURN-CODE special register is set to an unpredictable value. Therefore, even if your COBOL program terminates normally after successfully using the external CICS interface, the job step could end with an undefined return code.

To ensure that a meaningful return code occurs at termination, set the RETURN-CODE special register before you terminate your program. To make the job return code reflect the status of the last call to CICS, set the RETURN-CODE special register based on the response codes from the last call to the external CICS interface.

RELATED TASKS

CICS External Interfaces Guide

Compiling with the CICS option

Use the CICS compiler option to enable the integrated CICS translator and to specify CICS suboptions.

If you specify the NOCICS option, the compiler diagnoses and discards any CICS statements that it finds in your source program. If you have already used the separate CICS translator, you must use NOCICS.

You can specify the CICS option in any of the compiler option sources: compiler invocation, PROCESS or CBL statements, or installation default. If the CICS option is the COBOL installation default, you cannot specify CICS suboptions. However, making the CICS option the installation default is not recommended, because the changes that are made by the integrated CICS translator are not appropriate for non-CICS applications.

All CBL or PROCESS statements must precede any comment lines, in accordance with the rules for Enterprise COBOL.

The COBOL compiler passes to the integrated CICS translator the CICS suboption string that you provide in the CICS compiler option. The compiler does not analyze the suboption string.

When you use the integrated CICS translator, you must compile with the following options:

Table 56. Compiler options required for the integrated CICS translator

Compiler option	Comment
AFP	If your code runs on a version of CICS Transaction Server that is earlier than V4.1, you must specify AFP(VOLATILE).
CICS	If you specify NOLIB, DYNAM, or NORENT, the compiler forces NODYNAM, and RENT on.
NODYNAM	Must be in effect with CICS
RENT	Must be in effect with CICS

In addition, IBM recommends that you use the compiler option WORD(CICS) to cause the compiler to flag language elements that are not supported under CICS.

To compile your program with the integrated CICS translator, you can use the standard JCL procedural statements that are supplied with COBOL. In addition to specifying the above compiler options, you must change your JCL in two ways:

- Specify the STEPLIB override for the COBOL step.
- Add the data set that contains the integrated CICS translator services, unless these services are in the linklist.

The default name of the data set for CICS Transaction Server V5R1 is CICSTS51.CICS.SDFHLOAD, but your installation might have changed the name. For example, you might have the following line in your JCL:

```
//STEPLIB DD DSN=CICSTS41.CICS.SDFHLOAD,DISP=SHR
```

The COBOL compiler listing includes the error diagnostics (such as syntax errors in the CICS statements) that the integrated CICS translator generates. The listing reflects the input source; it does not include the COBOL statements that the integrated CICS translator generates.

Compiling a sequence of programs: When you use the CICS option to compile a source file that contains a sequence of COBOL programs, the order of precedence of the options from highest to lowest is:

- Options that are specified in the CBL or PROCESS card that initiates the unit of compilation
- Options that are specified when the compiler is started
- CICS default options

RELATED CONCEPTS

“Integrated CICS translator” on page 435

RELATED TASKS

“Coding COBOL programs to run under CICS” on page 429

“Separating CICS suboptions” on page 435

CICS Application Programming Guide

RELATED REFERENCES

"CICS" on page 312

"Conflicting compiler options" on page 304

Separating CICS suboptions

You can partition the specification of CICS suboptions into multiple CBL statements. CICS suboptions are cumulative. The compiler concatenates them from multiple sources in the order that they are specified.

For example, suppose that a JCL file has the following code:

```
//STEP1 EXEC IGYWC, . . .  
//PARM.COBOL="CICS("FLAG(I)")"  
//COBOL.SYSIN DD *  
  CBL CICS("DEBUG")  
  CBL CICS("LINKAGE")  
  IDENTIFICATION DIVISION.  
  PROGRAM-ID. COBOL1.
```

During compilation, the compiler passes the following CICS suboption string to the integrated CICS translator:

```
"FLAG(I) DEBUG LINKAGE"
```

The concatenated strings are delimited with single spaces and with a quotation mark or single quotation mark around the group. When the compiler finds multiple instances of the same CICS suboption, the last specification of the suboption in the concatenated string takes effect. The compiler limits the length of the concatenated CICS suboption string to 4 KB.

RELATED REFERENCES

"CICS" on page 312

Integrated CICS translator

When you compile a COBOL program using the CICS compiler option, the COBOL compiler works with the integrated CICS translator to handle both native COBOL and embedded CICS statements in the source program.

When the compiler encounters CICS statements, and at other significant points in the source program, the compiler interfaces with the integrated CICS translator. All text between EXEC CICS and END-EXEC statements is passed to the translator. The translator takes appropriate actions and then returns to the compiler, typically indicating which native language statements to generate.

Although you can still translate embedded CICS statements separately, it is recommended that you use the integrated CICS translator instead. Certain restrictions that apply when you use the separate translator do not apply when you use the integrated translator, and using the integrated translator provides several advantages:

- You can use Debug Tool to debug the original source instead of the expanded source that the separate CICS translator generates.
- You do not need to separately translate the EXEC CICS or EXEC DLI statements that are in copybooks.
- There is no intermediate data set for a translated but not compiled version of the source program.
- Only one output listing instead of two is produced.

- Using nested programs that contain EXEC CICS statements is simpler. DFHCOMMAREA and DFHEIBLK are generated with the GLOBAL attribute in the outermost program. You do not need to pass them as arguments on calls to nested programs or specify them in the USING phrase of the PROCEDURE DIVISION header of nested programs.
- You can keep nested programs that contain EXEC CICS statements in separate files, and include those nested programs by using COPY statements.
- REPLACE statements can affect EXEC CICS statements.
- You can compile programs that contain CICS statements in a batch compilation (compilation of a sequence of programs).
- Because the compiler generates binary fields in CICS control blocks with format COMP-5 instead of BINARY, there is no dependency on the setting of the TRUNC compiler option. You can use any setting of the TRUNC option in CICS programs, subject only to the requirements of the application logic and use of user-defined binary fields.

Note: The CICS documentation states that the EXCI translator option is not supported for programs compiled with the integrated CICS translator, but CICS has reversed this position. You can now compile with the EXCI translator option and ignore the warning message DFH7006I.

RELATED CONCEPTS

CICS Application Programming Guide (The integrated CICS translator)

RELATED TASKS

“Coding COBOL programs to run under CICS” on page 429

“Compiling with the CICS option” on page 433

RELATED REFERENCES

“CICS” on page 312

“TRUNC” on page 368

Using the separate CICS translator

To run a COBOL program under CICS, you can use the separate CICS translator to convert the CICS commands to COBOL statements, and then compile and link the program to create the executable module. However, using the CICS translator that is integrated with Enterprise COBOL is recommended. The separate CICS translator has not been updated for newer COBOL language such as floating comment delimiters and compiler directives. To use the latest features of the COBOL compiler, use the integrated CICS translator.

To translate CICS statements separately, use the COBOL3 translator option. This option causes the following line to be inserted:

```
CBL RENT,NODYNAM,
```

You can suppress the insertion of a CBL statement by using the CICS translator option NOCBLCARD.

After you use the separate CICS translator, use the following compiler options when you compile the program:

Table 57. Compiler options required for the separate CICS translator

Required compiler option	Condition
RENT	
NODYNAM	The program is translated by the CICS translator.

In addition, IBM recommends that you use the compiler option `WORD(CICS)` to cause the compiler to flag language elements that are not supported under CICS.

The following TRUNC compiler option recommendations are based on expected values for binary data items:

Table 58. TRUNC compiler options recommended for the separate CICS translator

Recommended compiler option	Condition
TRUNC(OPT)	All binary data items conform to the PICTURE and USAGE clause for those data items.
TRUNC(BIN)	Not all binary data items conform to the PICTURE and USAGE clause for those data items.

For example, if you use the separate CICS translator and have a data item defined as PIC S9(8) BINARY that might receive a value greater than eight digits, use the TRUNC(BIN) compiler option, change the item to USAGE COMP-5, or change the PICTURE clause.

You might also want to avoid using these options, which have no effect:

- ADV
- FASTSRT
- OUTDD

The input data set for the compiler is the data set that you received as a result of translation, which is SYSPUNCH by default.

RELATED CONCEPTS

“Integrated CICS translator” on page 435

RELATED TASKS

“Compiling with the CICS option” on page 433

CICS reserved-word table

COBOL provides an alternate reserved-word table (IGYCCICS) for CICS application programs. If you use the compiler option `WORD(CICS)`, COBOL words that are not supported under CICS are flagged with an error message.

In addition to the COBOL words restricted by the IBM-supplied default reserved-word table, the IBM-supplied CICS reserved-word table restricts the following COBOL words:

- CLOSE
- DELETE
- FD
- **FILE**

- **FILE-CONTROL**
- **INPUT-OUTPUT**
- I-O-CONTROL
- MERGE
- OPEN
- READ
- RERUN
- REWRITE
- **SD**
- **SORT**
- START
- WRITE

If you intend to use the SORT statement under CICS (COBOL supports an interface for the SORT statement under CICS), you must change the CICS reserved-word table to remove the words in **bold** above from the list of words marked as restricted.

RELATED TASKS

“Compiling with the CICS option” on page 433

“Sorting under CICS” on page 237

RELATED REFERENCES

“WORD” on page 372

Handling errors by using CICS HANDLE

The setting of the CBLPSHPOP runtime option affects the state of the HANDLE specifications when a program calls COBOL subprograms using a CALL statement.

When CBLPSHPOP is ON and a COBOL subprogram (not a nested program) is called with a CALL statement, the following actions occur:

1. As part of program initialization, the run time suspends the HANDLE specifications of the calling program (using EXEC CICS PUSH HANDLE).
2. The default actions for HANDLE apply until the called program issues its own HANDLE commands.
3. As part of program termination, the run time reinstates the HANDLE specifications of the calling program (using EXEC CICS POP HANDLE).

If you use the CICS HANDLE CONDITION or CICS HANDLE AID commands, the LABEL specified for the CICS HANDLE command must be in the same PROCEDURE DIVISION as the CICS command that causes branching to the CICS HANDLE label. You cannot use the CICS HANDLE commands with the LABEL option to handle conditions, aids, or abends that were caused by another program invoked with the COBOL CALL statement. Attempts to perform cross-program branching by using the CICS HANDLE command with the LABEL option result in a transaction abend.

If a condition, aid, or abend occurs in a nested program, the LABEL for the condition, aid, or abend must be in the same nested program; otherwise unpredictable results occur.

Performance considerations: When CBLPSHPOP is OFF, the run time does not perform CICS PUSH or POP on a CALL to any COBOL subprogram. If the subprograms do not use any of the EXEC CICS condition-handling commands, you can run with CBLPSHPOP(OFF), thus eliminating the overhead of the PUSH HANDLE and POP HANDLE commands. As a result, performance can be improved compared to running with CBLPSHPOP(ON).

If you are migrating an application from the VS COBOL II run time to the Language Environment run time, see the related reference for information about the CBLPSHPOP option for additional considerations.

“Example: handling errors by using CICS HANDLE”

RELATED TASKS

“Running efficiently with CICS, IMS, or VSAM” on page 672

RELATED REFERENCES

Enterprise COBOL Migration Guide (CICS HANDLE commands and the CBLPSHPOP runtime option)
Enterprise COBOL Version 4 Performance Tuning

Example: handling errors by using CICS HANDLE

The following example shows the use of CICS HANDLE in COBOL programs.

Program A has a CICS HANDLE CONDITION command and program B has no CICS HANDLE commands. Program A calls program B; program A also calls nested program A1. A condition is handled in one of three scenarios.

- (1) CBLPSHPOP(ON): If the CICS READ command in program B causes a condition, the condition is not handled by program A (the HANDLE specifications are suspended because the run time performs a CICS PUSH HANDLE). The condition turns into a transaction abend.
- (2) CBLPSHPOP(OFF): If the CICS READ command in program B causes a condition, the condition is not handled by program A (the run time diagnoses the attempt to perform cross-program branching by using a CICS HANDLE command with the LABEL option). The condition turns into a transaction abend.
- (3) If the CICS READ command in nested program A1 causes a condition, the flow of control goes to label ERR-1, and unpredictable results occur.

```
*****
* Program A *
*****
ID DIVISION.
PROGRAM-ID. A.
. . .
PROCEDURE DIVISION.
    EXEC CICS HANDLE CONDITION
        ERROR(ERR-1)
        END-EXEC.
    CALL 'B' USING DFHEIBLK DFHCOMMAREA.
    CALL 'A1'.
. . .
THE-END.
    EXEC CICS RETURN END-EXEC.
ERR-1.
. . .
* Nested program A1.
ID DIVISION.
```

```

PROGRAM-ID. A1.
PROCEDURE DIVISION.
    EXEC CICS READ          (3)
        FILE('LEDGER')
        INTO(RECORD)
        RIDFLD(ACCTNO)
        END-EXEC.
END PROGRAM A1.
END PROGRAM A.
*
*****
* Program B *
*****
ID DIVISION.
PROGRAM-ID. B.
. . .
PROCEDURE DIVISION.
    EXEC CICS READ          (1) (2)
        FILE('MASTER')
        INTO(RECORD)
        RIDFLD(ACCTNO)
        END-EXEC.
. . .
END PROGRAM B.

```

Chapter 21. Programming for a DB2 environment

In general, the coding for a COBOL program will be the same if you want the program to access a DB2 database. However, to retrieve, update, insert, and delete DB2 data and use other DB2 services, you must use SQL statements.

To communicate with DB2, do these steps:

- Code any SQL statements that you need, delimiting them with EXEC SQL and END-EXEC statements.
- Either use the DB2 stand-alone precompiler, or compile with the SQL compiler option and use the DB2 coprocessor.

RELATED CONCEPTS

“DB2 coprocessor”

“COBOL and DB2 CCSID determination” on page 447

RELATED TASKS

“Coding SQL statements” on page 442

“Compiling with the SQL option” on page 445

“Choosing the DYNAM or NODYNAM compiler option” on page 451

RELATED REFERENCES

“Differences in how the DB2 precompiler and coprocessor behave” on page 449

DB2 coprocessor

When you use the DB2 coprocessor (called *SQL statement coprocessor* by DB2), the compiler handles your source programs that contain embedded SQL statements without your having to use a separate precompile step.

To use the DB2 coprocessor, specify the SQL compiler option.

When the compiler encounters SQL statements in the source program, it interfaces with the DB2 coprocessor. All text between EXEC SQL and END-EXEC statements is passed to the coprocessor. The coprocessor takes appropriate actions for the SQL statements and indicates to the compiler which native COBOL statements to generate for them.

Although the use of a separate precompile step continues to be supported, it is recommended that you use the coprocessor instead:

- Interactive debugging with Debug Tool is enhanced when you use the coprocessor because you see the SQL statements (not the generated COBOL source) in the listing.
- The COBOL compiler listing includes the error diagnostics (such as syntax errors in the SQL statements) that the DB2 coprocessor generates.
- Certain restrictions on the use of COBOL language that apply when you use the precompile step do not apply when you use the DB2 coprocessor. With the coprocessor:
 - You can use SQL statements in any nested program. (With the precompiler, SQL statements are restricted to the outermost program.)
 - You can use SQL statements in copybooks.

- REPLACE statements work in SQL statements.

Compiling with the DB2 coprocessor generates a DB2 database request module (DBRM) along with the usual COBOL compiler outputs such as object module and listing. The DBRM writes to the data set that you specified in the DBRMLIB DD statement in the JCL for the COBOL compile step. As input to the DB2 bind process, the DBRM data set contains information about the SQL statements and host variables in the program.

RELATED CONCEPTS

“COBOL and DB2 CCSID determination” on page 447

RELATED TASKS

“Compiling with the SQL option” on page 445

RELATED REFERENCES

“Differences in how the DB2 precompiler and coprocessor behave” on page 449

“SQL” on page 358

Coding SQL statements

Delimit SQL statements with EXEC SQL and END-EXEC. The EXEC SQL and END-EXEC delimiters must each be complete on one line. You cannot continue them across multiple lines. Do not code COBOL statements within EXEC SQL statements.

You also need to do these special steps:

- Code an EXEC SQL INCLUDE statement to include an SQL communication area (SQLCA) in the WORKING-STORAGE SECTION or LOCAL-STORAGE SECTION of the outermost program. LOCAL-STORAGE is recommended for recursive programs and programs that use the THREAD compiler option.
- Define all host variables that you use in SQL statements in the WORKING-STORAGE SECTION, LOCAL-STORAGE SECTION, or LINKAGE SECTION. However, you do not need to identify them with EXEC SQL BEGIN DECLARE SECTION and EXEC SQL END DECLARE SECTION.

Restriction: You cannot use SQL statements in object-oriented classes or methods.

RELATED TASKS

“Using SQL INCLUDE with the DB2 coprocessor”

“Using character data in SQL statements” on page 443

“Using national decimal data in SQL statements” on page 444

“Using national group items in SQL statements” on page 444

“Using binary items in SQL statements” on page 445

“Determining the success of SQL statements” on page 445

DB2 Application Programming and SQL Guide (Coding SQL statements in a COBOL application)

RELATED REFERENCES

“Code-page determination for string host variables in SQL statements” on page 447

DB2 SQL Reference

Using SQL INCLUDE with the DB2 coprocessor

An SQL INCLUDE statement is treated identically to a native COBOL COPY statement when you use the SQL compiler option.

The following two lines are therefore treated the same way. (The period that ends the EXEC SQL INCLUDE statement is required.)

```
EXEC SQL INCLUDE name END-EXEC.  
COPY "name".
```

The processing of the *name* in an SQL INCLUDE statement follows the same rules as those of the literal in a COPY *literal-1* statement that does not have a REPLACING phrase.

The library search order for SQL INCLUDE statements is the same SYSLIB concatenation as the compiler uses to resolve COBOL COPY statements that do not specify a library-name.

RELATED REFERENCES

Chapter 18, "Compiler-directing statements," on page 381

"Differences in how the DB2 precompiler and coprocessor behave" on page 449
COPY statement (*Enterprise COBOL Language Reference*)

Using character data in SQL statements

You can code any of the following USAGE clauses to describe host variables for character data that you use in EXEC SQL statements: USAGE DISPLAY for single-byte or UTF-8 data, USAGE DISPLAY-1 for DBCS data, or USAGE NATIONAL for UTF-16 data.

When you use the stand-alone DB2 precompiler, you must specify the code page (CCSID) in EXEC SQL DECLARE statements for host variables that are declared with USAGE NATIONAL. You must specify the code page for host variables that are declared with USAGE DISPLAY or DISPLAY-1 only if the CCSID that is in effect for the COBOL CODEPAGE compiler option does not match the CCSIDs that are used by DB2 for character and graphic data.

Consider the following code. The two highlighted statements are unnecessary when you use the integrated DB2 coprocessor (with the SQLCCSID compiler option, as detailed in the related concept below), because the code-page information is handled implicitly.

```
CBL CODEPAGE(1140) NSYMBOL(NATIONAL)  
. . .  
WORKING-STORAGE SECTION.  
    EXEC SQL INCLUDE SQLCA END-EXEC.  
01  INT1 PIC S9(4) USAGE COMP.  
01  C1140.  
    49 C1140-LEN PIC S9(4) USAGE COMP.  
    49 C1140-TEXT PIC X(50).  
    EXEC SQL DECLARE :C1140 VARIABLE CCSID 1140 END-EXEC.  
01  G1200.  
    49 G1200-LEN PIC S9(4) USAGE COMP.  
    49 G1200-TEXT PIC N(50) USAGE NATIONAL.  
    EXEC SQL DECLARE :G1200 VARIABLE CCSID 1200 END-EXEC.  
. . .  
EXEC SQL FETCH C1 INTO :INT1, :C1140, :G1200 END-EXEC.
```

If you specify EXEC SQL DECLARE *variable-name* VARIABLE CCSID *nnnn* END-EXEC, that specification overrides the implied CCSID. For example, the following code would cause DB2 to treat C1208-TEXT as encoded in UTF-8 (CCSID 1208) rather than as encoded in the CCSID in effect for the COBOL CODEPAGE compiler option:

```
01 C1208.  
   49 C1208-LEN PIC S9(4) USAGE COMP.  
   49 C1208-TEXT PIC X(50).  
EXEC SQL DECLARE :C1208 VARIABLE CCSID 1208 END-EXEC.
```

The NSYMBOL compiler option has no effect on a character literal inside an EXEC SQL statement. Character literals in an EXEC SQL statement follow the SQL rules for character constants.

RELATED CONCEPTS

“COBOL and DB2 CCSID determination” on page 447

RELATED TASKS

DB2 Application Programming and SQL Guide (Coding SQL statements in a COBOL application)

RELATED REFERENCES

“Differences in how the DB2 precompiler and coprocessor behave” on page 449

“CODEPAGE” on page 313

DB2 SQL Reference

Using national decimal data in SQL statements

You can use national decimal host variables in EXEC SQL statements when you use either the integrated DB2 coprocessor or the DB2 precompiler. You do not need to specify the CCSID in EXEC SQL DECLARE statements in either case. CCSID 1200 is used automatically.

Any national decimal host variable that you specify in an EXEC SQL statement must have the following characteristics:

- It must be signed.
- It must be specified with the SIGN LEADING SEPARATE clause.
- USAGE NATIONAL must be in effect implicitly or explicitly.

RELATED CONCEPTS

“Formats for numeric data” on page 47

RELATED TASKS

“Defining national numeric data items” on page 133

RELATED REFERENCES

“Differences in how the DB2 precompiler and coprocessor behave” on page 449

Using national group items in SQL statements

You can use a national group item as a host variable in an EXEC SQL statement. The national group item is treated with group semantics (that is, as shorthand for the set of host variables that are subordinate to the group item) rather than as an elementary item.

Because all subordinate items in a national group must have USAGE NATIONAL, a national group item cannot describe a variable-length string.

RELATED TASKS

“Using national groups” on page 134

Using binary items in SQL statements

For binary data items that you specify in an EXEC SQL statement, you can define the data items as either USAGE COMP-5 or as USAGE BINARY, COMP, or COMP-4.

If you define the binary data items as USAGE BINARY, COMP, or COMP-4, use the TRUNC(BIN) option. (This technique might have a larger effect on performance than using USAGE COMP-5 on individual data items.) If instead TRUNC(OPT) or TRUNC(STD) is in effect, the compiler accepts the items but the data might not be valid because of the decimal truncation rules. You need to ensure that truncation does not affect the validity of the data.

RELATED CONCEPTS

"Formats for numeric data" on page 47

RELATED REFERENCES

"TRUNC" on page 368

Determining the success of SQL statements

When DB2 finishes executing an SQL statement, DB2 sends a return code in the SQLCA structure, with one exception, to indicate whether the operation succeeded or failed. In your program, test the return code and take any necessary action.

The exception occurs when a program runs under DSN from one of the alternate entry points of the TSO batch mode module IKJEFT01 (IKJEFT1A or IKJEFT1B). In this case, the return code is passed in register 15.

After execution of SQL statements, the content of the RETURN-CODE special register might not be valid. Therefore, even if your COBOL program terminates normally after successfully using SQL statements, the job step could end with an undefined return code. To ensure that a meaningful return code is given at termination, set the RETURN-CODE special register before terminating your program.

RELATED TASKS

DB2 Application Programming and SQL Guide (Coding SQL statements in a COBOL application)

Compiling with the SQL option

You use the SQL compiler option to enable the DB2 coprocessor and to specify DB2 suboptions.

You can specify the SQL option in any of the compiler option sources: compiler invocation, PROCESS or CBL statements, or installation default. You cannot specify DB2 suboptions when the SQL option is the COBOL installation default, but you can specify default DB2 suboptions by customizing the DB2 product installation defaults.

The DB2 suboption string that you provide in the SQL compiler option is made available to the DB2 coprocessor. Only the DB2 coprocessor views the contents of the string.

You can use standard JCL procedural statements to compile your program with the DB2 coprocessor. In addition to specifying the above compiler options, specify the following items in your JCL:

- DBRMLIB DD statement with the location for the generated database request module (DBRM).
- STEPLIB override for the COBOL step, adding the data set that contains the DB2 coprocessor services, unless these services are in the LNKLIST. Typically, this data set is this data set is xxxxxx.SDSNLOAD. For example, for DB2 9 it might be DSN910.SDSNLOAD, but your installation might have changed the name.

For example, you might have the following lines in your JCL:

```
//DBRMLIB DD DSN=PAYROLL.MONTHLY.DBRMLIB.DATA(MASTER),DISP=SHR
//STEPLIB DD DSN=DSN910.SDSNLOAD,DISP=SHR
```

Compiling a batch of programs: If you use the SQL option when compiling a source file that contains a sequence of COBOL programs (a batch compile sequence), SQL must be in effect for only the first program of the sequence. Although you can specify SQL upon compiler invocation, the option will be in effect for only the first program. If you specify SQL in a CBL or PROCESS statement for a program other than the first program in the batch, you will receive a compiler diagnostic message.

RELATED CONCEPTS

“DB2 coprocessor” on page 441

“COBOL and DB2 CCSID determination” on page 447

RELATED TASKS

“Separating DB2 suboptions”

“Choosing the DYNAM or NODYNAM compiler option” on page 451

RELATED REFERENCES

“DYNAM” on page 323

“SQL” on page 358

DB2 Command Reference

Separating DB2 suboptions

Because of the concatenation of multiple SQL option specifications, you can separate DB2 suboptions (which might not fit in one CBL statement) into multiple CBL statements.

The options that you include in the suboption string are cumulative. The compiler concatenates these suboptions from multiple sources in the order that they are specified. For example, suppose that your source file has the following code:

```
//STEP1 EXEC IGYWC, . . .
// PARM.COBOL='SQL("string1")'
//COBOL.SYSIN DD *
    CBL SQL("string2")
    CBL SQL("string3")
    IDENTIFICATION DIVISION.
    PROGRAM-ID. DRIVER1.
```

During compilation, the compiler passes the following suboption string to the DB2 coprocessor:

```
"string1 string2 string3"
```

The concatenated strings are delimited with single spaces. If the compiler finds multiple instances of the same SQL suboption, the last specification of that suboption in the concatenated string takes effect. The compiler limits the length of the concatenated DB2 suboption string to 4 KB.

COBOL and DB2 CCSID determination

All DB2 string data other than BLOB, BINARY, and VARBINARY data has an associated encoding scheme and a coded character set ID (CCSID). This is true for fixed-length and variable-length character strings, fixed-length and variable-length graphic character strings, CLOB host variables, and DBCLOB host variables.

When you use the integrated DB2 coprocessor, the determination of the code page CCSID that will be associated with the string host variables used in SQL statement processing depends on the setting of the COBOL SQLCCSID option, on the programming techniques used, and on various DB2 configuration options.

When you use the SQL and SQLCCSID COBOL compiler options, the CCSID value *nnnnn* that is specified in the CODEPAGE compiler option, or that is determined from the COBOL data type of a host variable, is communicated automatically from COBOL to DB2. DB2 associates the COBOL CCSID with host variables, overriding the CCSID that would otherwise be implied by DB2 external mechanisms and defaults. This associated CCSID is used for the processing of the SQL statements that reference host variables.

When you use the SQL and NOSQLCCSID compiler options, the CCSID value *nnnnn* that is specified in the CODEPAGE compiler option is used only for processing COBOL statements within the COBOL program; that CCSID is not used for the processing of SQL statements. Instead, DB2 assumes in processing SQL statements that host variable data values are encoded according to the CCSID or CCSIDs that are specified through DB2 external mechanisms and defaults.

RELATED CONCEPTS

"DB2 coprocessor" on page 441

RELATED TASKS

"Programming with the SQLCCSID or NOSQLCCSID option" on page 448

RELATED REFERENCES

"Code-page determination for string host variables in SQL statements"

"CODEPAGE" on page 313

"SQL" on page 358

"SQLCCSID" on page 359

Code-page determination for string host variables in SQL statements

When you use the integrated DB2 coprocessor (SQL compiler option), the code page for processing string host variables in SQL statements is determined as shown below, in descending order of precedence.

- A host variable that has USAGE NATIONAL is always processed by DB2 using CCSID 1200 (Unicode UTF-16). For example:

```
01 hostvariable pic n(10) usage national.
```

- An alphanumeric host variable that has an explicit FOR BIT DATA declaration is set by DB2 to CCSID 66535, which indicates that the variable does not represent encoded characters. For example:

```
EXEC SQL DECLARE hostvariable VARIABLE FOR BIT DATA END-EXEC
```

- A BLOB, BINARY, or VARBINARY host variable has no CCSID association. These string types do not represent encoded characters.

- A host variable for which you specify an explicit CCSID override in the SQLDA is processed with that CCSID.
- A host variable that you specify in a declaration with an explicit CCSID is processed with that CCSID. For example:
EXEC SQL DECLARE *hostvariable* VARIABLE CCSID *nnnnn* END-EXEC
- An alphanumeric host variable, if the SQLCCSID compiler option is in effect, is processed with the CCSID *nnnnn* from the CODEPAGE compiler option.
- A DBCS host variable, if the SQLCCSID option is in effect, is processed with the mapped value *nnnnnn*, which is the pure DBCS CCSID component of the mixed (MBCS) CCSID *nnnnn* from the CODEPAGE(*nnnnn*) compiler option.
- An alphanumeric or DBCS host variable, if the NOSQLCCSID option is in effect, is processed with the CCSID from the DB2 ENCODING bind option, if specified, or from the APPLICATION ENCODING set in DSNHDECP through the DB2 installation panel DSNTIPF.

RELATED REFERENCES

“CODEPAGE” on page 313

“SQLCCSID” on page 359

Programming with the SQLCCSID or NOSQLCCSID option

In general, the SQLCCSID option is recommended for new applications that use the integrated DB2 coprocessor, and as a long-term direction for existing applications. The NOSQLCCSID option is recommended as a mechanism for migrating existing precompiler-based applications to use the integrated DB2 coprocessor.

The SQLCCSID option is recommended for COBOL-DB2 applications that have any of these characteristics:

- Use COBOL Unicode support
- Use other COBOL syntax that is indirectly sensitive to CCSID encoding, such as XML support or object-oriented syntax for Java interoperability
- Process character data that is encoded in a CCSID that is different from the default CCSID assumed by DB2

The NOSQLCCSID option is recommended for applications that require the highest compatibility with the behavior of the DB2 precompiler.

For applications that use COBOL alphanumeric data items as host variables interacting with DB2 string data that is defined with the FOR BIT DATA subtype, you must either:

- Use the NOSQLCCSID compiler option
- Specify explicit FOR BIT DATA declarations for those host variables, for example:
EXEC SQL DECLARE *hostvariable* VARIABLE FOR BIT DATA END-EXEC

Usage notes

- If you use the DB2 DCLGEN command to generate COBOL declarations for a table, you can optionally create FOR BIT DATA declarations automatically. To do so, specify the DCLBIT(YES) option of the DCLGEN command.
- **Performance consideration:** Using the SQLCCSID compiler option could result in some performance overhead in SQL processing, because with SQLCCSID in effect the default DB2 CCSID association mechanism is overridden with a mechanism that works on a per-host-variable basis.

RELATED CONCEPTS

“DB2 coprocessor” on page 441

RELATED REFERENCES

“SQLCCSID” on page 359

Differences in how the DB2 precompiler and coprocessor behave

The sections that follow enumerate the differences in behavior between the stand-alone COBOL DB2 precompiler and the integrated COBOL DB2 coprocessor.

For details about the CCSID determination under the DB2 precompiler and coprocessor, see “COBOL and DB2 CCSID determination” on page 447.

Period at the end of EXEC SQL INCLUDE statements

Precompiler: The DB2 precompiler does not require that a period end each EXEC SQL INCLUDE statement. If a period is specified, the precompiler processes it as part of the statement. If a period is not specified, the precompiler accepts the statement as if a period had been specified.

Coprocessor: The DB2 coprocessor treats each EXEC SQL INCLUDE statement like a COPY statement, and requires that a period end the statement. For example:

```
IF A = B THEN
    EXEC SQL INCLUDE some_code_here END-EXEC.
ELSE
    . . .
END-IF
```

Note that the period does not terminate the IF statement.

EXEC SQL INCLUDE and nested COPY REPLACING

Precompiler: With the DB2 precompiler, an EXEC SQL INCLUDE statement can reference a copybook that contains a COPY statement that uses the REPLACING phrase.

Coprocessor: With the DB2 coprocessor, an EXEC SQL INCLUDE statement cannot reference a copybook that contains a COPY statement that uses the REPLACING phrase. The coprocessor processes each EXEC SQL INCLUDE statement identically to a COPY statement, and nested COPY statements cannot have the REPLACING phrase.

EXEC SQL and REPLACE or COPY REPLACING

Precompiler: With the DB2 precompiler, COBOL REPLACE statements and the REPLACING phrase of the COPY statement act on the expanded source created from the EXEC SQL statement. COBOL rules for REPLACE and REPLACING are used.

Coprocessor: With the DB2 coprocessor, REPLACE and COPY . . . REPLACING statements act on the original source program, including EXEC SQL statements.

Different behavior can result, as in the following example:

```
REPLACE == ABC == By == XYZ ==.
01 G.
   02 ABC PIC X(10).
   . . .
   EXEC SQL SELECT * INTO :G.ABC FROM TABLE1 END-EXEC
```

With the precompiler, the reference to G.ABC will appear as ABC of G in the expanded source and will be replaced with XYZ of G. With the coprocessor, replacement will not occur, because ABC is not delimited by separators in the original source string G.ABC.

Source code after an END-EXEC statement

Precompiler: The DB2 precompiler ignores any code that follows END-EXEC statements on the same line.

Coprocessor: The DB2 coprocessor processes code that follows END-EXEC statements on the same line.

Multiple definitions of host variables

Precompiler: The DB2 precompiler does not require that host variable references be unique. The first definition that maps to a valid DB2 data type is used.

Coprocessor: The DB2 coprocessor requires that each host variable reference be unique. The coprocessor diagnoses nonunique references to host variables. You must fully qualify host variable references to make them unique.

EXEC SQL statement continuation lines

Precompiler: The DB2 precompiler requires that EXEC SQL statements start in columns 12 through 72. Continuation lines of the statements can start anywhere in columns 8 through 72.

Coprocessor: The DB2 coprocessor requires that all lines of an EXEC SQL statement, including continuation lines, be coded in columns 12 through 72.

Bit-data host variables

Precompiler: With the DB2 precompiler, a COBOL alphanumeric data item can be used as a host variable to hold DB2 character data that has subtype FOR BIT DATA. An explicit EXEC SQL DECLARE VARIABLE statement that declares that host variable as FOR BIT DATA is not required.

Coprocessor: With the DB2 coprocessor, a COBOL alphanumeric data item can be used as a host variable to hold DB2 character data that has subtype FOR BIT DATA if an explicit EXEC SQL DECLARE VARIABLE statement for that host variable is specified in the COBOL program. For example:

```
EXEC SQL DECLARE :HV1 VARIABLE FOR BIT DATA END-EXEC.
```

As an alternative to adding EXEC SQL DECLARE . . . FOR BIT DATA statements, you can use the NOSQLCCSID compiler option. For details, see the related reference about code-page determination below.

SQL-INIT-FLAG

Precompiler: With the DB2 precompiler, if you pass host variables that might be located at different addresses when the program is called more than once, the called program must reset SQL-INIT-FLAG. Resetting this flag indicates to DB2 that storage must be initialized when the next SQL statement runs. To reset the flag, insert the statement MOVE ZERO TO SQL-INIT-FLAG in the PROCEDURE DIVISION of the called program ahead of any executable SQL statements that use those host variables.

Coprocessor: With the DB2 coprocessor, the called program does not need to reset SQL-INIT-FLAG. An SQL-INIT-FLAG is automatically defined in the program to aid program portability. However, statements that modify SQL-INIT-FLAG, such as MOVE ZERO TO SQL-INIT-FLAG, have no effect on the SQL processing in the program.

RELATED CONCEPTS

“DB2 coprocessor” on page 441

“COBOL and DB2 CCSID determination” on page 447

RELATED REFERENCES

“Code-page determination for string host variables in SQL statements” on page 447

“SQLCCSID” on page 359

Choosing the DYNAM or NODYNAM compiler option

For COBOL programs that have EXEC SQL statements, your choice of the compiler option DYNAM or NODYNAM depends on the operating environment.

When you run under:

- TSO or IMS: You can use either the DYNAM or NODYNAM compiler option.
Note that IMS and DB2 share a common alias name, DSNHLI, for the language interface module. You must concatenate your libraries as follows:
 - If you use IMS with the DYNAM option, concatenate the IMS library first.
 - If you run your application only under DB2, concatenate the DB2 library first.
- CICS or the DB2 call attach facility (CAF): You must use the NODYNAM compiler option.

Because stored procedures use CAF, you must also compile COBOL stored procedures with the NODYNAM option.

RELATED TASKS

“Compiling with the SQL option” on page 445

DB2 Application Programming and SQL Guide (Programming for the call attachment facility)

RELATED REFERENCES

“DYNAM” on page 323

Chapter 22. Developing COBOL programs for IMS

Although much of the coding of a COBOL program will be the same when running under IMS, be aware of the following recommendations and restrictions.

In COBOL, IMS message processing programs (MPPs) do not use non-IMS input or output statements such as READ, WRITE, REWRITE, OPEN, and CLOSE.

With Enterprise COBOL, you can invoke IMS facilities using the following interfaces:

- CBLTDLI call
- Language Environment callable service CEETDLI
- EXEC SQLIMS statements

CEETDLI behaves essentially the same way as CBLTDLI, except that CEETDLI enables LE condition handling to be used. There are some instances when you cannot use Language Environment condition handling when using CBLTDLI under IMS.

You can also run object-oriented COBOL programs in a Java dependent region. You can mix the object-oriented COBOL and Java languages in a single application.

RELATED CONCEPTS

“IMS SQL coprocessor”

RELATED TASKS

“Coding SQLIMS statements” on page 454

“Compiling with the SQLIMS option” on page 455

“Compiling and linking COBOL programs for running under IMS” on page 457

“Using object-oriented COBOL and Java under IMS” on page 458

“Calling a COBOL method from a Java application under IMS” on page 458

“Building a mixed COBOL-Java application that starts with COBOL” on page 459

“Writing mixed-language IMS applications” on page 459

IMS SQL coprocessor

When you use the IMS SQL coprocessor (called *SQL statement coprocessor* by IMS), the compiler handles your source programs that contain embedded SQL statements.

When the compiler encounters SQLIMS statements in the source program, it interfaces with the IMS SQL coprocessor. All text between EXEC SQLIMS and END-EXEC statements is passed to the coprocessor. The coprocessor takes appropriate actions for the SQLIMS statements and indicates to the compiler what native COBOL statements to generate for them.

Notes:

- The IMS SQL coprocessor processes embedded SQLIMS statements, not embedded SQL statements.

- IMS program might contain EXEC SQL statements for accessing a DB2 SQL database, EXEC SQLIMS statements for accessing an IMS DLI databases, or both. The SQL option enables EXEC SQL statements while the SQLIMS option enables EXEC SQLIMS statements.

With the IMS SQL coprocessor, you can use statements in the following ways:

- Use EXEC SQLIMS statements in any nested program.
- Use EXEC SQLIMS statements in COPYBOOKS.
- REPLACE statements work in SQLIMS statements.

RELATED TASKS

“Coding SQLIMS statements”

“Compiling with the SQLIMS option” on page 455

“Compiling and linking COBOL programs for running under IMS” on page 457

RELATED REFERENCES

“SQLIMS” on page 360

Coding SQLIMS statements

Delimit SQLIMS statements with EXEC SQLIMS and END-EXEC. The EXEC SQLIMS and END-EXEC delimiters must each be complete on one line. Do not code COBOL statements within EXEC SQLIMS statements.

Code an EXEC SQLIMS INCLUDE statement to include an SQLIMS communication area (SQLCA) in the WORKING-STORAGE SECTION or LOCAL-STORAGE SECTION of the outermost program. The LOCAL-STORAGE SECTION is recommended for recursive programs and programs that use the THREAD compiler option.

Restriction: You cannot use SQLIMS statements in object-oriented classes or methods.

RELATED TASKS

“Using SQLIMS INCLUDE with the IMS SQL coprocessor”

“Using character data in SQLIMS statements” on page 455

“Using binary items in SQLIMS statements” on page 455

“Determining the success of SQLIMS statements” on page 455

Using SQLIMS INCLUDE with the IMS SQL coprocessor

An SQLIMS INCLUDE statement is treated identically to a native COBOL COPY statement when you use the SQLIMS compiler option.

The following two lines are therefore treated the same way. The period that ends the EXEC SQLIMS INCLUDE statement is required.

```
EXEC SQLIMS INCLUDE name END-EXEC.  
COPY "name".
```

The processing of the *name* in an SQLIMS INCLUDE statement follows the same rules as the literal in a COPY *literal-1* statement that does not have a REPLACING phrase.

The library search order for SQLIMS INCLUDE statements is the same SYSLIB concatenation as the compiler uses to resolve COBOL COPY statements that do not specify a library-name.

RELATED REFERENCES

Chapter 18, "Compiler-directing statements," on page 381
COPY statement (*Enterprise COBOL Language Reference*)

Using character data in SQLIMS statements

Alphanumeric host data items for use in EXEC SQLIMS statements (host variables) must be defined as USAGE DISPLAY.

Note: Do not use character data items that are defined with USAGE DISPLAY-1 or USAGE NATIONAL as SQLIMS host variables.

RELATED CONCEPTS

"IMS SQL coprocessor" on page 453

RELATED REFERENCES

"CODEPAGE" on page 313

Using binary items in SQLIMS statements

For binary data items that you specify in an EXEC SQLIMS statement, you can define the data items as either USAGE COMP-5 or as USAGE BINARY, COMP, or COMP-4.

If you define the binary data items as USAGE BINARY, COMP, or COMP-4, use the TRUNC(BIN) compiler option. Using this option might have a larger effect on performance than using USAGE COMP-5 on individual data items. If instead you use the TRUNC(OPT) or TRUNC(STD) compiler options, the compiler accepts the items but the data might not be valid because of the decimal truncation rules. You must ensure that truncation does not affect the validity of the data.

RELATED CONCEPTS

"Formats for numeric data" on page 47

RELATED REFERENCES

"TRUNC" on page 368

Determining the success of SQLIMS statements

When IMS finishes running an SQLIMS statement, IMS sends a return code in the SQLIMSCA structure to indicate whether the operation succeeded or failed. In your program, test the return code and take any necessary action.

After execution of SQLIMS statements, the content of the RETURN-CODE special register might not be valid. Therefore, even if a program terminates normally after successfully using SQLIMS statements, the job step might end with an undefined return code. To ensure that a meaningful return code is given at termination, set the RETURN-CODE special register before you end the program.

RELATED TASKS

IMS Application Programming Guide

Compiling with the SQLIMS option

Use the SQLIMS compiler option to enable the IMS SQL coprocessor and to specify IMS suboptions.

You can specify the SQLIMS option in any of the compiler option sources: compiler invocation, PROCESS or CBL statements, or installation default. However, you cannot specify IMS suboptions when the SQLIMS option is the COBOL installation default. The IMS suboption string in the SQLIMS compiler option is only available to the IMS SQL coprocessor.

To use the IMS SQL coprocessor, you must compile with the SQLIMS option and IMS must be available on the system on which you compile.

You can use standard JCL procedural statements to compile your program with the IMS SQL coprocessor. In addition to specifying the above compiler options, specify the following item in your JCL:

STEPLIB override for the COBOL step, adding the data set that contains the IMS SQL coprocessor services, unless these services are in the LNKST. Typically, the data set is IMS.SDFSRESL but your installation might have changed the name.

For example, you might have the following lines in your JCL:

```
//STEPLIB DD DSN=IMS.SDFSRESL,DISP=SHR
```

Compiling a batch of programs:

If you use the SQLIMS option when you compile a source file that contains a sequence of COBOL programs (a batch compile sequence), SQLIMS is in effect for only the first program of the sequence. Although you can specify SQLIMS upon compiler invocation, the option is in effect for only the first program. If you specify SQLIMS in a CBL or PROCESS statement for a program other than the first program in the batch, a compiler diagnostic message is issued.

RELATED CONCEPTS

“IMS SQL coprocessor” on page 453

RELATED TASKS

“Separating IMS suboptions”

RELATED REFERENCES

“SQL” on page 358

Separating IMS suboptions

Because of the concatenation of multiple SQLIMS option specifications, you can separate IMS suboptions (which might not fit in one CBL statement) into multiple CBL statements.

The options that you include in the suboption string are cumulative. The compiler concatenates these suboptions from multiple sources in the order that they are specified. For example, suppose that your source file contains the following code:

```
//STEP1 EXEC IGYWC, . . .
// PARM.COBOL='SQLIMS("string1")'
//COBOL.SYSIN DD *
    CBL SQLIMS("string2")
    CBL SQLIMS("string3")
    IDENTIFICATION DIVISION.
    PROGRAM-ID. DRIVER1.
```

During compilation, the compiler passes the following suboption string to the IMS SQL coprocessor:

"string1 string2 string3"

The concatenated strings are delimited with single spaces. If the compiler finds multiple instances of the same SQLIMS suboption, the last specification of that suboption in the concatenated string takes effect. The compiler limits the length of the concatenated IMS suboption string to 4 KB.

RELATED CONCEPTS

"IMS SQL coprocessor" on page 453

RELATED TASKS

"Compiling with the SQLIMS option" on page 455

Compiling and linking COBOL programs for running under IMS

For best performance in the IMS environment, use the RENT compiler option. RENT causes COBOL to generate reentrant code. You can then run your application programs in either *preloaded* mode (the programs are always resident in storage) or *nonpreload* mode without having to recompile using different options.

Preloading can boost performance because subsequent requests for a program can be handled faster when the program is already in storage (rather than being fetched from a library each time it is needed).

For IMS programs, using the RENT compiler option is recommended. You must use the RENT compiler option for a program that is to be run preloaded or both preloaded and nonpreloaded. When you preload a program object that contains COBOL programs, all of the COBOL programs in that program object must be compiled using the RENT option.

You can place programs compiled with the RENT option in the z/OS link pack area. There they can be shared among the IMS dependent regions.

To run above the 16 MB line, an application program must be compiled with RENT. The data for IMS application programs can reside above the 16 MB line, and you can use DATA(31) RENT for programs that use IMS services.

For proper execution of COBOL programs under IMS, observe the following guidelines for the link-edit attributes:

- To link program objects that contain only COBOL programs compiled with the RENT compiler option, link as RENT.
- To link program objects that contain a mixture of COBOL RENT programs and other programs, use the link-edit attributes recommended for the other programs.

RELATED CONCEPTS

"Storage and its addressability" on page 39

RELATED TASKS

"Choosing the DYNAM or NODYNAM compiler option" on page 451
Language Environment Programming Guide (Condition handling under IMS)

RELATED REFERENCES

"DATA" on page 318

Using object-oriented COBOL and Java under IMS

You can mix object-oriented COBOL and Java in an application that runs in a Java dependent region.

For example, you can:

- Call a COBOL method from a Java application. You can build the messaging portion of your application in Java and call COBOL methods to access IMS databases.
- Build a mixed COBOL and Java application that starts with the main method of a COBOL class and that invokes Java routines.

You must run these applications in either a Java message processing (JMP) dependent region or a Java batch processing (JBP) dependent region. A program that reads from the message queue (regardless of the language) must run in a JMP dependent region.

RELATED TASKS

"Defining a factory section" on page 621

Chapter 30, "Writing object-oriented programs," on page 589

Chapter 31, "Communicating with Java methods," on page 633

Chapter 16, "Compiling, linking, and running OO applications," on page 291

IMS Application Programming Guide

Calling a COBOL method from a Java application under IMS

You can use the object-oriented language support in Enterprise COBOL to write COBOL methods that a Java program can call under IMS.

When you define a COBOL class and compile it using Enterprise COBOL, the compiler generates a Java class definition with native methods and the object code that implements those native methods. You can then create an instance and invoke the methods of this class from a Java program that runs in a Java dependent region, just as you would use any other class.

For example, you can define a COBOL class that uses the appropriate DL/I calls to access an IMS database. To make the implementation of this class available to a Java program, do the following steps:

1. Compile the COBOL class using Enterprise COBOL. The compiler generates a Java source file (.java) that contains the class definition, and an object module (.o) that contains the implementation of the native methods.
2. Compile the generated Java source file using the Java compiler. The Java compiler creates a class file (.class).
3. Link the object code into a dynamic link library (DLL) in the z/OS UNIX file system (.so). The directory that contains the COBOL DLLs must be listed in the LIBPATH, as specified in the IMS.PROCLIB member that is indicated by the ENVIRON= parameter of the IMS region procedure.
4. Update the sharable application class path in the master JVM options member (ibm.jvm.sharable.application.class.path in the IMS.PROCLIB member that is specified by the JVMOPMAS= parameter of the IMS region procedure) to enable the JVM to access the Java class file.

A Java program cannot call procedural COBOL programs directly. To reuse existing COBOL IMS code, use one of the following techniques:

- Restructure the COBOL code as a method in a COBOL class.
- Write a COBOL class definition and method that serves as a wrapper for the existing procedural code. The wrapper code can use COBOL CALL statements to access procedural COBOL programs.

RELATED TASKS

Chapter 16, “Compiling, linking, and running OO applications,” on page 291

“Structuring OO applications” on page 630

“Wrapping procedure-oriented COBOL programs” on page 630

IMS Application Programming Guide

Building a mixed COBOL-Java application that starts with COBOL

An application that runs in a Java dependent region must start with the main method of a class.

A COBOL class definition that has a main factory method meets this requirement; therefore, you can use a main factory method as the first routine of a mixed COBOL and Java application under IMS.

Enterprise COBOL generates a Java class with a main method, which the Java dependent region can find, instantiate, and invoke. Although you can code the entire application in COBOL, you would probably build this type of application to call a Java routine. When the COBOL run time runs within the JVM of a Java dependent region, it automatically finds and uses this JVM to invoke methods on Java classes.

The COBOL application should use DL/I calls for processing messages (GU and GN) and synchronizing transactions (CHKP).

RELATED TASKS

“Structuring OO applications” on page 630

IMS Application Programming Guide

IBM SDK, Java Technology Edition

Writing mixed-language IMS applications

When you write mixed-language IMS applications, you need to be aware of the effects of the STOP RUN statement. You also need to understand how to process messages and synchronize transactions, access databases, and use the application interface block (AIB).

RELATED TASKS

“Using the STOP RUN statement”

“Processing messages and synchronizing transactions” on page 460

“Accessing databases” on page 460

“Using the application interface block” on page 460

Using the STOP RUN statement

If you use the STOP RUN statement in the COBOL portion of your application, the statement terminates all COBOL and Java routines (including the JVM).

Control is returned immediately to IMS. The program and the transaction are left in a stopped state.

Processing messages and synchronizing transactions

IMS message-processing applications must do all message processing and transaction synchronization either in COBOL or Java, rather than distributing this logic between application components written in both languages.

COBOL components use CALL statements to DL/I services to process messages (GU and GN) and synchronize transactions (CHKP). Java components use Java classes for IMS to do these functions. You can use object instances of classes derived from IMSFieldMessage to communicate entire IMS messages between the COBOL and Java components of the application.

RELATED TASKS

IMS Application Programming Guide

RELATED REFERENCES

IMS Application Programming API Reference

Accessing databases

You can use either Java, COBOL, or a mixture of the two languages to access IMS databases.

Limitation: EXEC SQL statements for DB2 database access are not supported in COBOL routines that run in a Java dependent region.

Recommendation: Do not access the same database program communication block (PCB) from both Java and COBOL. The Java and COBOL parts of the application share the same database position. Changes in database position from calls in one part of the application affect the database position in another part of the application. (This problem occurs whether the affected parts of an application are written in the same language or in different languages.)

Suppose that a Java component of a mixed application builds an SQL SELECT clause and uses Java Database Connectivity (JDBC) to query and retrieve results from an IMS database. The Java class libraries for IMS construct the appropriate request to IMS to establish the correct position in the database. If you then invoke a COBOL method that builds a segment search argument (SSA) and issues a GU (Get Unique) request to IMS against the same database PCB, the request probably altered the position in the database for that PCB. If so, subsequent JDBC requests to retrieve more records by using the initial SQL SELECT clause are incorrect because the database position changed. If you must access the same PCB from multiple languages, reestablish the database position after an interlanguage call before you access more records in the database.

RELATED TASKS

IMS Application Programming Guide

Using the application interface block

COBOL applications that run in a Java dependent region normally must use the AIB interface because the Java dependent region does not provide PCB addresses to its application.

To use the AIB interface, specify the PCB requested for the call by placing the PCB name (which must be defined as part of the PSBGEN) in the resource name field of

the AIB. (The AIB requires that all PCBs in a program specification block (PSB) definition have a name.) You do not specify the PCB address directly, and your application does not need to know the relative PCB position in the PCB list. Upon the completion of the call, the AIB returns the PCB address that corresponds to the PCB name that the application passed.

Alternatively, you can obtain PCB addresses by making an IMS INQY call using subfunction FIND, and the PCB name as the resource name. The call returns the address of the PCB, which you can then pass to a COBOL program. (This approach still requires that the PCB name be defined as part of the PSBGEN, but the application does not have to use the AIB interface.)

“Example: using the application interface block”

RELATED TASKS

IMS Application Programming Guide

Example: using the application interface block:

The following example shows how you can use the AIB interface in a COBOL application.

```
Local-storage section.  
    copy AIB.  
    . . .  
Linkage section.  
01 IOPCB.  
    05 logtterm      pic x(08).  
    05               pic x(02).  
    05 tpstat       pic x(02).  
    05 iodate       pic s9(7)   comp-3.  
    05 iotime       pic s9(7)   comp-3.  
    05               pic x(02).  
    05 seqnum       pic x(02).  
    05 mod          pic x(08).  
Procedure division.  
    Move spaces to input-area  
    Move spaces to AIB  
    Move "DFSAIB" to AIBRID  
    Move length of AIB to AIBRLEN  
    Move "IOPCB" to AIBRSNM1  
    Move length of input-area to AIBOALEN  
    Call "CEETDLI" using GU, AIB, input-area  
    Set address of IOPCB to AIBRESA1  
    If tpstat = spaces  
* . . process input message
```

Chapter 23. Running COBOL programs under z/OS UNIX

To run COBOL programs in the z/OS UNIX environment, compile them using Enterprise COBOL or COBOL for OS/390 & VM. The programs must be reentrant, so use the compiler and linker option RENT.

If you are going to run the programs from the z/OS UNIX file system, use the linker option AMODE 31. Any AMODE 24 program that you call from within a z/OS UNIX application must reside in an MVS PDS or PDSE.

Restrictions: The following restrictions apply to running under z/OS UNIX:

- SORT and MERGE statements are not supported.
- You cannot use the old COBOL interfaces for preinitialization (runtime option RTEREUS) to establish a reusable environment.
- You cannot run a COBOL program compiled with the N0THREAD option in more than one thread. If you start a COBOL application in a second thread, you get a software condition from the COBOL run time. You can run N0THREAD COBOL programs in the initial process thread (IPT) or in one non-IPT that you create from a C or PL/I routine.

You can run a COBOL program in more than one thread if you compile all the COBOL programs in the application with the THREAD option.

You can use Debug Tool to debug z/OS UNIX programs in remote debug mode, for example, by using the Debug Perspective of Rational Developer for System z, or in full-screen mode (MFI) using a VTAM[®] terminal.

RELATED TASKS

Chapter 15, “Compiling under z/OS UNIX,” on page 283

“Running OO applications under z/OS UNIX” on page 293

“Running in z/OS UNIX environments”

“Setting and accessing environment variables” on page 464

“Calling UNIX/POSIX APIs” on page 466

“Accessing main program parameters under z/OS UNIX” on page 468

Language Environment Programming Guide

RELATED REFERENCES

“RENT” on page 352

Running in z/OS UNIX environments

You can run COBOL programs in any of the z/OS UNIX execution environments, either from within a z/OS UNIX shell or from outside a shell.

- You can run programs in either the OMVS shell (OMVS) or the ISPF shell (ISHELL).

Enter the program-name at the shell prompt. The program must be in the current directory or in your search path.

You can specify runtime options only by setting the environment variable `_CEE_RUNOPTS` before starting the program.

You can run programs that reside in a cataloged MVS data set from a shell by using the `tso` utility. For example:

```
tso "call 'my.loadlib(myprog)'"
```

The ISPF shell can direct stdout and stderr only to a z/OS UNIX file, not to your terminal.

- From outside a shell, you can run programs either under TSO/E or in batch. To call a COBOL program that resides in a z/OS UNIX file from the TSO/E prompt, use the BPXBATCH utility or a spawn() syscall in a REXX exec. To call a COBOL program that resides in a z/OS UNIX file with the EXEC JCL statement, use the BPXBATCH utility.

RELATED TASKS

“Running OO applications under z/OS UNIX” on page 293
“Setting and accessing environment variables”
“Calling UNIX/POSIX APIs” on page 466
“Accessing main program parameters under z/OS UNIX” on page 468
“Defining and allocating QSAM files” on page 174
“Allocating line-sequential files” on page 214
“Allocating VSAM files” on page 206
“Displaying values on a screen or in a file (DISPLAY)” on page 35
Language Environment Programming Guide (Running POSIX-enabled programs)

RELATED REFERENCES

“TEST” on page 364
UNIX System Services User’s Guide (The BPXBATCH utility)
Language Environment Programming Reference

Setting and accessing environment variables

You can set environment variables for z/OS UNIX COBOL programs either from the shell with commands export and set, or from the program.

Although setting and resetting environment variables from the shell before you begin to run a program is a typical procedure, you can set, reset, and access environment variables from the program while it is running.

If you are running a program with BPXBATCH, you can set environment variables by using an STDENV DD statement.

To reset an environment variable as if it had not been set, use the z/OS UNIX shell command unset. To reset an environment variable from a COBOL program, call the setenv() function.

To see the values of all environment variables, use the export command with no parameters. To access the value of an environment variable from a COBOL program, call the getenv() function.

“Example: setting and accessing environment variables” on page 466

RELATED TASKS

“Running in z/OS UNIX environments” on page 463
“Setting environment variables that affect execution” on page 465
“Accessing main program parameters under z/OS UNIX” on page 468
“Running OO applications under z/OS UNIX” on page 293
“Setting environment variables under z/OS UNIX” on page 283

RELATED REFERENCES

“Runtime environment variables” on page 465

Setting environment variables that affect execution

To set environment variables for z/OS UNIX COBOL programs from a shell, use the `export` or `set` command. To set environment variables from within the program, call POSIX functions `setenv()` or `putenv()`.

For example, to set the environment variable `MYFILE`:

```
export MYFILE=/usr/mystuff/notes.txt
```

“Example: setting and accessing environment variables” on page 466

RELATED TASKS

“Calling UNIX/POSIX APIs” on page 466

“Setting environment variables under z/OS UNIX” on page 283

RELATED REFERENCES

“Runtime environment variables”

Runtime environment variables

Several runtime variables are of interest for COBOL programs.

These are the runtime environment variables:

_CEE_ENVFILE

Specifies a file from which to read environment variables.

_CEE_RUNOPTS

Specifies runtime options.

CLASSPATH

Specifies directory paths of Java `.class` files required for an OO application.

COBJVMINIOPTIONS

Specifies Java virtual machine (JVM) options to be used when COBOL initializes a JVM.

_IGZ_SYSOUT

Specifies where to direct `DISPLAY` output. `stdout` and `stderr` are the only allowable values.

LIBPATH

Specifies directory paths of dynamic link libraries.

PATH Specifies directory paths of executable programs.

STEPLIB

Specifies location of programs that are not in the `LNKLST`.

RELATED TASKS

“Displaying data on the system logical output device” on page 36

RELATED REFERENCES

XL C/C++ Programming Guide (_CEE_ENVFILE)

Language Environment Programming Reference

Example: setting and accessing environment variables

The following example shows how you can access and set environment variables from a COBOL program by calling the standard POSIX functions `getenv()` and `putenv()`.

Because `getenv()` and `putenv()` are C functions, you must pass arguments BY VALUE. Pass character strings as BY VALUE pointers that point to null-terminated strings. Compile programs that call these functions with the `NODYNAM` and `PGMNAME(LONGMIXED)` options.

```
CBL pgmname(longmixed),nodynam
Identification division.
Program-id. "envdemo".
Data division.
Working-storage section.
01 P pointer.
01 PATH pic x(5) value Z"PATH".
01 var-ptr pointer.
01 var-len pic 9(4) binary.
01 putenv-arg pic x(14) value Z"MYVAR=ABCDEFGH".
01 rc pic 9(9) binary.
Linkage section.
01 var pic x(5000).
Procedure division.
* Retrieve and display the PATH environment variable
  Set P to address of PATH
  Call "getenv" using by value P returning var-ptr
  If var-ptr = null then
    Display "PATH not set"
  Else
    Set address of var to var-ptr
    Move 0 to var-len
    Inspect var tallying var-len
      for characters before initial X"00"
    Display "PATH = " var(1:var-len)
  End-if
* Set environment variable MYVAR to ABCDEFG
  Set P to address of putenv-arg
  Call "putenv" using by value P returning rc
  If rc not = 0 then
    Display "putenv failed"
  Stop run
End-if
Goback.
```

Calling UNIX/POSIX APIs

You can call standard UNIX/POSIX functions from z/OS UNIX COBOL programs and from traditional z/OS COBOL programs by using the `CALL literal` statement. These functions are part of Language Environment.

Because these are C functions, you must pass arguments BY VALUE. Pass character strings as BY VALUE pointers that point to null-terminated strings. You must use the compiler options `NODYNAM` and `PGMNAME(LONGMIXED)` when you compile programs that call these functions.

You can call the `fork()`, `exec()`, and `spawn()` functions from a COBOL program or from a non-COBOL program in the same process as COBOL programs. However, be aware of these restrictions:

- From a forked process you cannot access any COBOL sequential, indexed, or relative files that were open when you issued the `fork`. File status code 92 is

- returned if you attempt such access (CLOSE, READ, WRITE, REWRITE, DELETE, or START). You can access line-sequential files that were open at the time of a fork.
- You cannot use the fork() function in a process in which any of the following conditions are true:
 - A COBOL SORT or MERGE is running.
 - A declarative is running.
 - The process has more than one Language Environment enclave (COBOL run unit).
 - The process has used any of the COBOL reusable environment interfaces.
 - The process has ever run a VS COBOL II program.
 - With one exception, DD allocations are not inherited from a parent process to a child process. The exception is the local spawn, which creates a child process in the same address space as the parent process. You request a local spawn by setting the environment variable `_BPX_SHAREAS=YES` before you invoke the spawn() function.

The exec() and spawn() functions start a new Language Environment enclave in the new UNIX process. Therefore the target program of the exec() or spawn() function is a main program, and all COBOL programs in the process start in initial state with all files closed.

Sample code for calling some of the POSIX routines is provided in the SIGYSAMP data set.

Table 59. Samples with POSIX function calls

Purpose	Sample	Functions used
Shows how to use some of the file and directory routines	IGYTFL1	<ul style="list-style-type: none"> • getcwd() • mkdir() • rmdir() • access()
Shows how to use the iconv routines to convert data	IGYTCNV	<ul style="list-style-type: none"> • iconv_open() • iconv() • iconv_close()
Shows the use of the exec() routine to run a new program along with other process-related routines	IGYTEXC, IGYTEXC1	<ul style="list-style-type: none"> • fork() • getpid() • getppid() • execl() • perror() • wait()
Shows how to get the errno value	IGYTERNO, IGYTGETE	<ul style="list-style-type: none"> • perror() • fopen()

Table 59. Samples with POSIX function calls (continued)

Purpose	Sample	Functions used
Shows the use of the interprocess communication message routines	IGYTMSQ, IGYTMSQ2	<ul style="list-style-type: none"> • ftok() • msgget() • msgsnd() • perror() • fopen() • fclose() • msgrcv() • msgctl() • perror()

RELATED TASKS

“Running in z/OS UNIX environments” on page 463

“Setting and accessing environment variables” on page 464

“Accessing main program parameters under z/OS UNIX”

Language Environment Programming Guide

RELATED REFERENCES

XL C/C++ Run-Time Library Reference

UNIX System Services Programming: Assembler Callable Services Reference

Accessing main program parameters under z/OS UNIX

When you run a COBOL program from the z/OS UNIX shell command line or with an `exec()` or `spawn()` function, the parameter list consists of three parameters passed by reference. You can access these parameters with standard COBOL coding.

argument count

A binary fullword integer that contains the number of elements in each of the arrays that are passed in the second and third parameters.

argument length list

An array of pointers. The *n*th entry in the array is the address of a fullword binary integer that contains the length of the *n*th entry in the argument list.

argument list

An array of pointers. The *n*th entry in the array is the address of the *n*th character string passed as an argument in the `spawn()` or `exec()` function or in the command invocation. Each character string is null-terminated.

This array is never empty. The first argument is the character string that represents the name of the file associated with the process being started.

“Example: accessing main program parameters under z/OS UNIX” on page 469

RELATED TASKS

“Running in z/OS UNIX environments” on page 463

“Setting and accessing environment variables” on page 464

“Calling UNIX/POSIX APIs” on page 466

“Accessing main program parameters under z/OS” on page 505

Example: accessing main program parameters under z/OS UNIX

The following example shows the three parameters that are passed by reference, and shows the coding that you can use to access them.

```

Identification division.
Program-id. "EXECED".
*****
* This sample program displays arguments received via exec() *
* function of z/OS UNIX *
*****
Data division.
Working-storage section.
01 curr-arg-count pic 9(9) binary value zero.
Linkage section.
01 arg-count pic 9(9) binary. (1)
01 arg-length-list. (2)
    05 arg-length-addr pointer occurs 1 to 99999
       depending on curr-arg-count.
01 arg-list. (3)
    05 arg-addr pointer occurs 1 to 99999
       depending on curr-arg-count.
01 arg-length pic 9(9) binary.
01 arg pic X(65536).
Procedure division using arg-count arg-length-list arg-list.
*****
* Display number of arguments received *
*****
    Display "Number of arguments received: " arg-count
*****
* Display each argument passed to this program *
*****
    Perform arg-count times
        Add 1 to curr-arg-count
    * *****
    * * Set address of arg-length to address of current *
    * * argument length and display *
    * *****
        Set Address of arg-length
        to arg-length-addr(curr-arg-count)
        Display
        "Length of Arg " curr-arg-count " = " arg-length
    * *****
    * * Set address of arg to address of current argument *
    * * and display *
    * *****
        Set Address of arg to arg-addr(curr-arg-count)
        Display "Arg " curr-arg-count " = " arg (1:arg-length - 1)
    End-Perform
    Display "Display of arguments complete."
    Goback.

```

- (1) This count contains the number of elements in the arrays that are passed in the second and third parameters.
- (2) This array contains a pointer to the length of the *n*th entry in the argument list.
- (3) This array contains a pointer to the *n*th character string passed as an argument in the spawn() or exec() function or in the command invocation.

Part 4. Structuring complex applications

Chapter 24. Using subprograms

Many applications consist of several separately compiled programs linked together. A *run unit* (the COBOL term that is synonymous with the Language Environment term *enclave*) includes one or more object programs and can include object programs written in other Language Environment member languages.

Language Environment provides interlanguage support that lets your Enterprise COBOL programs call and be called by programs that meet the requirements of Language Environment.

Name prefix alert: Do not use program-names that start with prefixes used by IBM products. If you use programs whose names start with such prefixes, CALL statements might resolve to IBM library or compiler routines rather than to the intended program. For a list of prefixes to avoid, see the related task about identifying a program.

RELATED CONCEPTS

“Main programs, subprograms, and calls”

RELATED TASKS

“Identifying a program” on page 3

“Ending and reentering main programs or subprograms” on page 474

“Transferring control to another program” on page 475

“Making recursive calls” on page 487

“Calling to and from object-oriented programs” on page 487

“Using procedure and function pointers” on page 487

“Making programs reentrant” on page 490

“Handling COBOL limitations with multithreading” on page 522

Language Environment Writing ILC Communication Applications

RELATED REFERENCES

Language Environment Programming Guide (Register conventions)

Main programs, subprograms, and calls

If a COBOL program is the first program in a run unit, that COBOL program is the *main program*. Otherwise, it and all other COBOL programs in the run unit are *subprograms*. No specific source-code statements or options identify a COBOL program as a main program or subprogram.

Whether a COBOL program is a main program or subprogram can be significant for either of two reasons:

- Effect of program termination statements
- State of the program when it is reentered after returning

In the PROCEDURE DIVISION, a program can call another program (generally called a *subprogram*), and this called program can itself call other programs. The program that calls another program is referred to as the *calling* program, and the program it calls is referred to as the *called* program. When the processing of the called program is completed, the called program can either transfer control back to the calling program or end the run unit.

The called COBOL program starts running at the top of the PROCEDURE DIVISION.

RELATED TASKS

“Ending and reentering main programs or subprograms”

“Transferring control to another program” on page 475

“Making recursive calls” on page 487

RELATED REFERENCES

Language Environment Programming Guide

Ending and reentering main programs or subprograms

Whether a program is left in its last-used state or its initial state, and to which caller it returns, can depend on the termination statements that you use.

You can use any of three termination statements in a program, but they have different effects as shown in the following table.

Table 60. Effects of termination statements

Termination statement	Main program	Subprogram
EXIT PROGRAM	No action taken	Return to calling program without ending the run unit. An implicit EXIT PROGRAM statement is generated if the called program has no next executable statement. In a threaded environment, the thread is not terminated unless the program is the first (oldest) one in the thread.
STOP RUN	Return to calling program. ¹ (Might be the operating system, and application will end.) STOP RUN terminates the run unit, and deletes all dynamically called programs in the run unit and all programs link-edited with them. (It does not delete the main program.) In a threaded environment, the entire Language Environment enclave is terminated, including all threads running within the enclave.	Return directly to the program that called the main program. ¹ (Might be the operating system, and application will end.) STOP RUN terminates the run unit, and deletes all dynamically called programs in the run unit and all programs link-edited with them. (It does not delete the main program.) In a threaded environment, the entire Language Environment enclave is terminated, including all threads running within the enclave.
GOBACK	Return to calling program. ¹ (Might be the operating system, and application will end.) GOBACK terminates the run unit, and deletes all dynamically called programs in the run unit and all programs link-edited with them. (It does not delete the main program.) In a threaded environment, the thread is terminated. ²	Return to calling program. In a threaded environment, if the program is the first program in a thread, the thread is terminated. ²

Table 60. Effects of termination statements (continued)

Termination statement	Main program	Subprogram
1.	If the main program is called by a program written in another language that does not follow Language Environment linkage conventions, return is to this calling program.	
2.	If the thread is the initial thread of execution in an enclave, the enclave is terminated.	

A subprogram is usually left in its *last-used state* when it terminates with EXIT PROGRAM or GOBACK. The next time the subprogram is called in the run unit, its internal values are as they were left, except that return values for PERFORM statements are reset to their initial values. (In contrast, a main program is initialized each time it is called.)

There are some cases in which programs will be in their initial state:

- A subprogram that is dynamically called and then canceled will be in the initial state the next time it is called.
- A program that has the INITIAL clause in the PROGRAM-ID paragraph will be in the initial state each time it is called.
- Data items defined in the LOCAL-STORAGE SECTION will be reset to the initial state specified by their VALUE clauses each time the program is called.

RELATED CONCEPTS

“Comparison of WORKING-STORAGE and LOCAL-STORAGE” on page 14
Language Environment Programming Guide (What happens during termination:
 thread termination)

RELATED TASKS

“Calling nested COBOL programs” on page 483
 “Making recursive calls” on page 487

Transferring control to another program

You can use several different methods to transfer control to another program: static calls, dynamic calls, calls to nested programs, and calls to dynamic link libraries (DLLs).

In addition to making calls between Enterprise COBOL programs, you can also make static and dynamic calls between Enterprise COBOL and programs compiled with older compilers in all environments including CICS.

For restrictions about making calls with older levels of programs, see *Interoperability with older levels of IBM COBOL programs* in the *Enterprise COBOL Migration Guide*.

Calling nested programs lets you create applications using structured programming techniques. You can use nested programs in place of PERFORM procedures to prevent unintentional modification of data items. Call nested programs using either the CALL *literal* or CALL *identifier* statement.

Calls to dynamic link libraries (DLLs) are an alternative to COBOL dynamic CALL, and are well suited to object-oriented COBOL applications, z/OS UNIX programs, and applications that interoperate with C/C++.

Under z/OS, linking two program objects together results logically in a single program with a primary entry point and an alternate entry point, each with its own name. Each name by which a subprogram is to be dynamically called must be known to the system. You must specify each such name in binder (linkage-editor) control statements as either a NAME or an ALIAS of the program object that contains the subprogram.

RELATED CONCEPTS

“AMODE switching” on page 479

“Performance considerations of static and dynamic calls” on page 481

“Nested programs” on page 484

RELATED TASKS

“Making static calls”

“Making dynamic calls” on page 477

“Making both static and dynamic calls” on page 481

“Calling nested COBOL programs” on page 483

RELATED REFERENCES

Enterprise COBOL Migration Guide

(Interoperability with older levels of IBM COBOL programs)

Making static calls

When you use the CALL *literal* statement in a program that is compiled using the NODYNAM and NODLL compiler options, a static call occurs. With these options, all CALL *literal* calls are handled as static calls.

With static calls statement, the COBOL program and all called programs are part of the same program object. When control is transferred, the called program already resides in storage, and a branch to it takes place. Subsequent executions of the CALL statement make the called program available in its last-used state unless the called program has the INITIAL attribute. In that case, the called program and each program directly or indirectly contained within it are placed into their initial state each time the called program is called within a run unit.

If you specify alternate entry points, a static CALL statement can use any alternate entry point to enter the called subprogram.

“Examples: static and dynamic CALL statements” on page 482

RELATED CONCEPTS

“Performance considerations of static and dynamic calls” on page 481

RELATED TASKS

“Making dynamic calls” on page 477

“Making both static and dynamic calls” on page 481

“Calling to and from object-oriented programs” on page 487

RELATED REFERENCES

“DLL” on page 321

“DYNAM” on page 323

CALL statement (*Enterprise COBOL Language Reference*)

Making dynamic calls

When you use a *CALL literal* statement in a program that is compiled using the DYNAM and the NODLL compiler options, or when you use the *CALL identifier* statement in a program that is compiled using the NODLL compiler option, a dynamic call occurs.

In these forms of the CALL statement, the called COBOL subprogram is not link-edited with the main program. Instead, it is link-edited into a separate program object, and is loaded at run time only when it is required (that is, when called). The program-name in the PROGRAM-ID paragraph or ENTRY statement must be identical to the corresponding program object name or program object alias of the program object that contains the program.

Each subprogram that you call with a dynamic CALL statement can be part of a different program object that is a member of either the system link library or a private library that you supply. In either case it must be in an MVS load library; it cannot reside in the z/OS UNIX file system. When a dynamic CALL statement calls a subprogram that is not resident in storage, the subprogram is loaded from secondary storage into the region or partition that contains the main program, and a branch to the subprogram is performed.

The first dynamic call to a subprogram within a run unit obtains a fresh copy of the subprogram. Subsequent calls to the same subprogram (by either the original caller or any other subprogram within the same run unit) result in a branch to the same copy of the subprogram in its last-used state, provided the subprogram does not possess the INITIAL attribute. Therefore, the reinitialization of either of the following items is your responsibility:

- GO TO statements that have been altered
- Data items

If you call the same COBOL program in different run units, a separate copy of WORKING-STORAGE is allocated for each run unit.

Restrictions: You cannot make dynamic calls to:

- COBOL DLL programs
- COBOL programs compiled with the PGMNAME(LONGMIXED) option, unless the program-name is less than or equal to eight characters in length and is all uppercase
- COBOL programs compiled with the PGMNAME(LONGUPPER) option, unless the program-name is less than or equal to eight characters in length
- More than one entry point in the same COBOL program (unless an intervening CANCEL statement was executed)

“Examples: static and dynamic CALL statements” on page 482

RELATED CONCEPTS

“When to use a dynamic call with subprograms” on page 478

“Performance considerations of static and dynamic calls” on page 481

RELATED TASKS

“Canceling a subprogram” on page 478

“Making static calls” on page 476

“Making both static and dynamic calls” on page 481

RELATED REFERENCES

“DLL” on page 321

“DYNAM” on page 323

ENTRY statement (*Enterprise COBOL Language Reference*)

CALL statement (*Enterprise COBOL Language Reference*)

Language Environment Programming Reference

Canceling a subprogram

When you issue a CANCEL statement for a subprogram, the storage that is occupied by the subprogram is freed. A subsequent call to the subprogram functions as though it were the first call. You can cancel a subprogram from a program other than the original caller.

If the called subprogram has more than one entry point, ensure that an intervening CANCEL statement is executed before you specify different entry points in a dynamic CALL statement to that subprogram.

After a CANCEL statement is processed for a dynamically called contained program, the program will be in its first-used state. However, the program is not loaded with the initial call, and storage is not freed after the program is canceled.

“Examples: static and dynamic CALL statements” on page 482

RELATED CONCEPTS

“Performance considerations of static and dynamic calls” on page 481

When to use a dynamic call with subprograms

Your decision to use dynamic calls with subprograms depends on factors such as location of the program object, frequency of calls to the subprograms, size of the subprograms, ease of maintenance, the need to call subprograms in their unused state, the need for AMODE switching, and when the program-names are known.

The program object that you want to dynamically call must be in an MVS load library rather than in the z/OS UNIX file system.

If subprograms are called in only a few conditions, you can use dynamic calls to bring in the subprograms only when needed.

If the subprograms are very large or there are many of them, using static calls might require too much main storage. Less total storage might be required to call and cancel one, then call and cancel another, than to statically call both.

If you are concerned about ease of maintenance, dynamic calls can help. Applications do not have to be link-edited again when dynamically called subprograms are changed.

When you cannot use the INITIAL attribute to ensure that a subprogram is placed in its unused state each time that it is called, you can set the unused state by using a combination of dynamic CALL and CANCEL statements. When you cancel a subprogram that was first called by a COBOL program, the next call causes the subprogram to be reinitialized to its unused state.

Using the CANCEL statement to explicitly cancel a subprogram that was dynamically loaded and branched to by a non-COBOL program does not result in any action being taken to release the subprogram's storage or to delete the subprogram.

Suppose you have an AMODE 24 program in the same run unit with Enterprise COBOL programs that you want to run in 31-bit addressing mode. COBOL dynamic call processing includes AMODE switching for AMODE 24 programs that call AMODE 31 programs, and vice versa. To have this implicit AMODE switching done, the Language Environment runtime options ALL31(OFF) and STACK(, ,BELOW) must be in effect.

When dynamic call is performed, control is passed from the caller to a Language Environment library routine. After the switching is performed, control passes to the called program; the save area for the library routine will be positioned between the save area for the caller program and the save area for the called program.

If you do not know the program-name to be called until run time, use the format CALL *identifier*, where *identifier* is a data item that will contain the name of the called program at run time. For example, you could use CALL *identifier* when the program to be called varies depending on conditional processing in your program. CALL *identifier* is always dynamic, even if you use the NODYNAM compiler option.

“Examples: static and dynamic CALL statements” on page 482

RELATED CONCEPTS

“AMODE switching”

“Performance considerations of static and dynamic calls” on page 481

RELATED TASKS

“Making dynamic calls” on page 477

RELATED REFERENCES

“DYNAM” on page 323

CALL statement (*Enterprise COBOL Language Reference*)
Language Environment Programming Reference

AMODE switching

When you have an application that has COBOL subprograms, some of the COBOL subprograms can be AMODE 31 and some can be AMODE 24. To have this mixed AMODE support, the calls must be dynamic and the Language Environment runtime options ALL31(OFF) and STACK(, ,BELOW) must be in effect.

If your application consists of only COBOL programs, and you are using dynamic calls, each COBOL subprogram will always be entered in the proper AMODE. For example, if you are using a dynamic call from an AMODE 31 COBOL program to an AMODE 24 COBOL program, the AMODE is automatically switched.

However, if you are using procedure pointers, function pointers, or other languages that call COBOL subprograms, you must ensure that when a COBOL program is called more than once in an enclave, it is entered in the same AMODE each time that it is called. The AMODE is not automatically switched in this case.

The following scenario shows that AMODE problems can arise when procedure pointers are used to call COBOL subprograms. This scenario is not supported because the COBOL program COBOLY is not entered in the same AMODE each time that it is called.

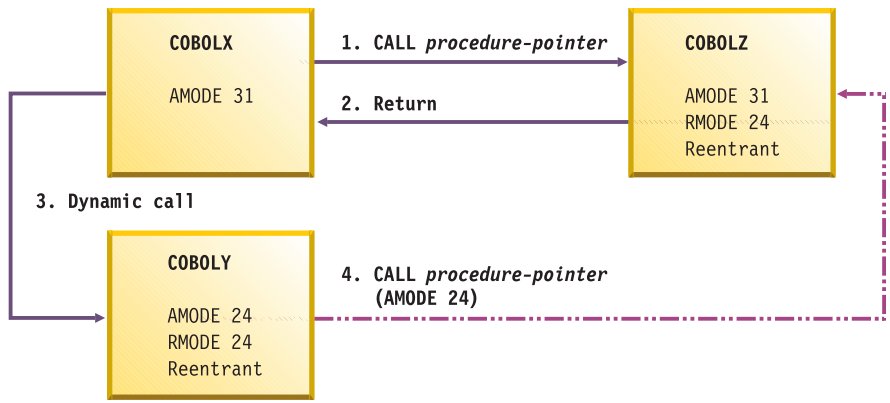

Legend	
Successful call	—————→
Erroneous call	- - - - -→

1. COBOLX is AMODE 31. It uses the SET statement to set a procedure pointer to COBOLZ. COBOLZ is a reentrant program object and is AMODE 31 and RMODE 24. COBOLX calls COBOLZ using the procedure pointer. COBOLZ is entered in AMODE 31.
2. COBOLZ returns to COBOLX.
3. COBOLX dynamically calls COBOLY, passing the procedure pointer for COBOLZ. COBOLY is a reentrant program object, and is AMODE 24 and RMODE 24. COBOLY is entered in AMODE 24.
4. COBOLY calls COBOLZ using the procedure pointer. This call causes COBOLZ to be entered in AMODE 24, which is not the same AMODE in which COBOLZ was entered when it was called the first time.

The following scenario uses a mix of COBOL and assembler language. This scenario is not supported because the COBOL program COBOLB is not entered in the same AMODE each time that it is called.

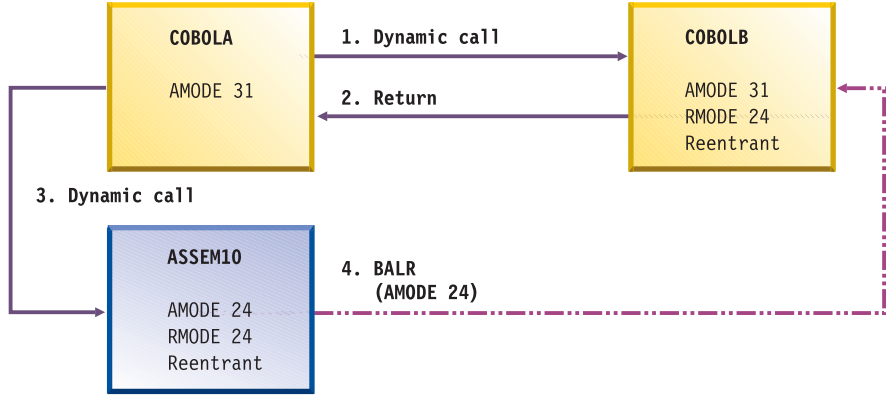

Legend	
Successful call	—————→
Erroneous call	- - - - -→

1. COBOLA is AMODE 31. COBOLA dynamically calls COBOLB. COBOLB is a reentrant program object and is AMODE 31 and RMODE 24. COBOLB is entered in AMODE 31.
2. COBOLB returns to COBOLA.

3. COBOLA dynamically calls ASSEM10, which is in assembler language. ASSEM10 is a reentrant program object, and is AMODE 24 and RMODE 24. ASSEM10 is entered in AMODE 24.
4. ASSEM10 loads COBOLB. ASSEM10 does a BALR instruction to COBOLB. COBOLB is entered in AMODE 24, which is not the same AMODE in which COBOLB was entered when it was called the first time.

RELATED CONCEPTS

“Storage and its addressability” on page 39

“When to use a dynamic call with subprograms” on page 478

RELATED TASKS

“Making dynamic calls” on page 477

RELATED REFERENCES

Language Environment Programming Reference (ALL31)

Performance considerations of static and dynamic calls

Because a statically called program is link-edited into the same program object as the calling program, a static call is faster than a dynamic call. A static call is the preferred method if your application does not require the services of the dynamic call.

Statically called programs cannot be deleted using CANCEL, so static calls might take more main storage. If storage is a concern, think about using dynamic calls. Storage usage of calls depends on whether:

- The subprogram is called only a few times. Regardless of whether it is called, a statically called program is loaded into storage; a dynamically called program is loaded only when it is called.
- You subsequently delete the dynamically called subprogram with a CANCEL statement.

You cannot delete a statically called program, but you can delete a dynamically called program. Using a dynamic call and then a CANCEL statement to delete the dynamically called program after it is no longer needed in the application (and not after each call to it) might require less storage than using a static call.

RELATED CONCEPTS

“When to use a dynamic call with subprograms” on page 478

RELATED TASKS

“Making static calls” on page 476

“Making dynamic calls” on page 477

Making both static and dynamic calls

You can use both static and dynamic CALL statements in the same program if you compile the program with the NODYNAM compiler option.

In this case, with the CALL *literal* statement, the called subprogram will be link-edited with the main program into one program object. The CALL *identifier* statement results in the dynamic invocation of a separate program object.

When a dynamic CALL statement and a static CALL statement to the same subprogram are issued within one program, a second copy of the subprogram is

loaded into storage. Because this arrangement does not guarantee that the subprogram will be left in its last-used state, results can be unpredictable.

RELATED REFERENCES
 "DYNAM" on page 323

Examples: static and dynamic CALL statements

This example shows how you can code static and dynamic calls.

The example has three parts:

- Code that uses a static call to call a subprogram
- Code that uses a dynamic call to call the same subprogram
- The subprogram that is called by the two types of calls

The following example shows how you would code static calls:

```
PROCESS NODYNAM NODLL
IDENTIFICATION DIVISION.
DATA DIVISION.
WORKING-STORAGE SECTION.
01 RECORD-2                PIC X.                (6)
01 RECORD-1.              (2)
   05 PAY                  PICTURE S9(5)V99.
   05 HOURLY-RATE          PICTURE S9V99.
   05 HOURS                PICTURE S99V9.
. . .
PROCEDURE DIVISION.
CALL "SUBPROG" USING RECORD-1.          (1)
CALL "PAYMASTR" USING RECORD-1 RECORD-2. (5)
STOP RUN.
```

The following example shows how you would code dynamic calls:

```
DATA DIVISION.
WORKING-STORAGE SECTION.
77 PGM-NAME                PICTURE X(8).
01 RECORD-2                PIC x.                (6)
01 RECORD-1.              (2)
   05 PAY                  PICTURE S9(5)V99.
   05 HOURLY-RATE          PICTURE S9V99.
   05 HOURS                PICTURE S99V9.
. . .
PROCEDURE DIVISION.
. . .
MOVE "SUBPROG" TO PGM-NAME.
CALL PGM-NAME USING RECORD-1.          (1)
CANCEL PGM-NAME.
MOVE "PAYMASTR" TO PGM-NAME.          (4)
CALL PGM-NAME USING RECORD-1 RECORD-2. (5)
STOP RUN.
```

The following example shows a called subprogram that is called by each of the two preceding calling programs:

```
IDENTIFICATION DIVISION.
PROGRAM-ID. SUBPROG.
DATA DIVISION.
LINKAGE SECTION.
01 PAYREC.                (2)
   10 PAY                  PICTURE S9(5)V99.
   10 HOURLY-RATE          PICTURE S9V99.
   10 HOURS                PICTURE S99V9.
77 PAY-CODE                PICTURE 9.          (6)
PROCEDURE DIVISION USING PAYREC.      (1)
```

```

. . .
EXIT PROGRAM. (3)
ENTRY "PAYMASTR" USING PAYREC PAY-CODE. (5)
. . .
GOBACK. (7)

```

- (1) Processing begins in the calling program. When the first CALL statement is executed, control is transferred to the first statement of the PROCEDURE DIVISION in SUBPROG, which is the called program.
In each of the CALL statements, the operand of the first USING option is identified as RECORD-1.
- (2) When SUBPROG receives control, the values within RECORD-1 are made available to SUBPROG; however, in SUBPROG they are referred to as PAYREC.
The PICTURE character-strings within PAYREC and PAY-CODE contain the same number of characters as RECORD-1 and RECORD-2, although the descriptions are not identical.
- (3) When processing within SUBPROG reaches the EXIT PROGRAM statement, control is returned to the calling program. Processing continues in that program until the second CALL statement is executed.
- (4) In the example of a dynamically called program, because the second CALL statement refers to another entry point within SUBPROG, a CANCEL statement is executed before the second CALL statement.
- (5) With the second CALL statement in the calling program, control is again transferred to SUBPROG, but this time processing begins at the statement following the ENTRY statement in SUBPROG.
- (6) The values within RECORD-1 are again made available to PAYREC. In addition, the value in RECORD-2 is now made available to SUBPROG through the corresponding USING operand, PAY-CODE.
When control is transferred the second time from the statically linked program, SUBPROG is made available in its last-used state (that is, if any values in SUBPROG storage were changed during the first execution, those changed values are still in effect). When control is transferred from the dynamically linked program, however, SUBPROG is made available in its initial state, because of the CANCEL statement that has been executed.
- (7) When processing reaches the GOBACK statement, control is returned to the calling program at the statement immediately after the second CALL statement.

In any given execution of the called program and either of the two calling programs, if the values within RECORD-1 are changed between the time of the first CALL and the second, the values passed at the time of the second CALL statement will be the changed, not the original, values. If you want to use the original values, you must save them.

Calling nested COBOL programs

By calling nested programs, you can create applications that use structured programming techniques. You can also call nested programs instead of PERFORM procedures to prevent unintentional modification of data items.

Use either CALL *literal* or CALL *identifier* statements to make calls to nested programs.

You can call a contained program only from its directly containing program unless you identify the contained program as `COMMON` in its `PROGRAM-ID` paragraph. In that case, you can call the *common program* from any program that is contained (directly or indirectly) in the same program as the common program. Only contained programs can be identified as `COMMON`. Recursive calls are not allowed.

Follow these guidelines when using nested program structures:

- Code an `IDENTIFICATION DIVISION` in each program. All other divisions are optional.
- Optionally make the name of each contained program unique. Although the names of contained programs are not required to be unique (as described in the related reference about scope of names), making the names unique could help make your application more maintainable. You can use any valid user-defined word or an alphanumeric literal as the name of a contained program.
- In the outermost program, code any `CONFIGURATION SECTION` entries that might be required. Contained programs cannot have a `CONFIGURATION SECTION`.
- Include each contained program in the containing program immediately before the `END PROGRAM` marker of the containing program.
- Use an `END PROGRAM` marker to terminate contained and containing programs.

You cannot use the `THREAD` option when compiling programs that contain nested programs.

RELATED CONCEPTS

“Nested programs”

RELATED REFERENCES

“Scope of names” on page 486

Nested programs

A COBOL program can *nest*, or contain, other COBOL programs. The nested programs can themselves contain other programs. A nested program can be directly or indirectly contained in a program.

There are four main advantages to nesting called programs:

- Nested programs provide a method for creating modular functions and maintaining structured programming techniques. They can be used analogously to perform procedures (using the `PERFORM` statement), but with more structured control flow and with the ability to protect local data items.
- Nested programs let you debug a program before including it in an application.
- Nested programs enable you to compile an application with a single invocation of the compiler.
- Calls to nested programs have the best performance of all the forms of COBOL `CALL` statements.

The following example describes a nested structure that has directly and indirectly contained programs:

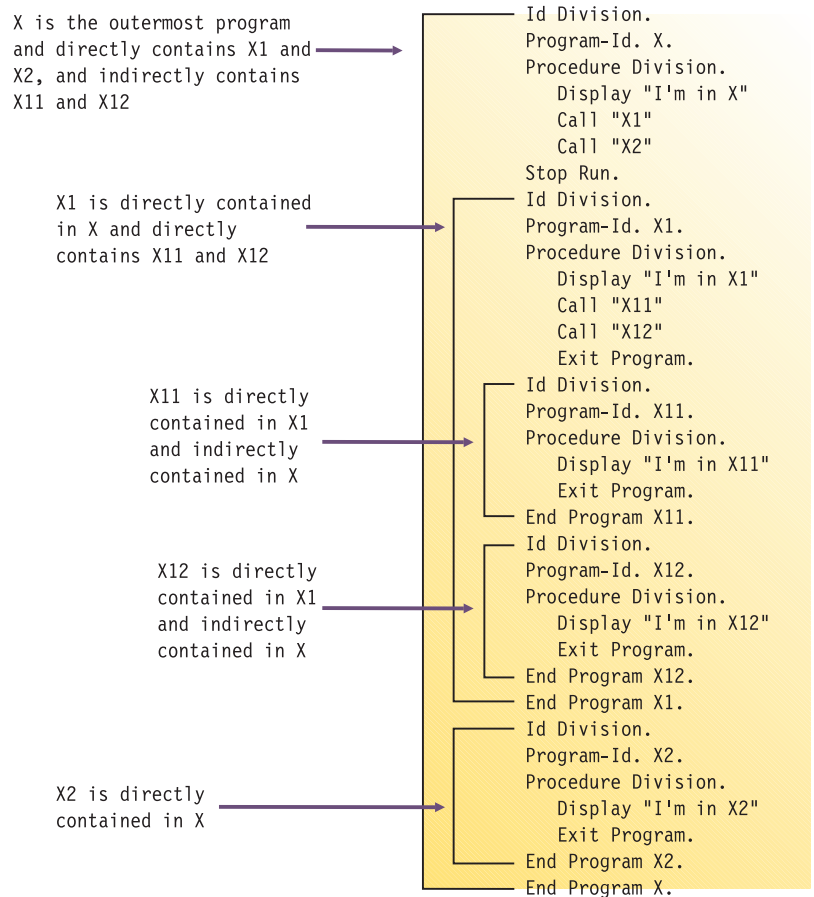

“Example: structure of nested programs”

RELATED TASKS

“Calling nested COBOL programs” on page 483

RELATED REFERENCES

“Scope of names” on page 486

Example: structure of nested programs

The following example shows a nested structure with some contained programs that are identified as COMMON.

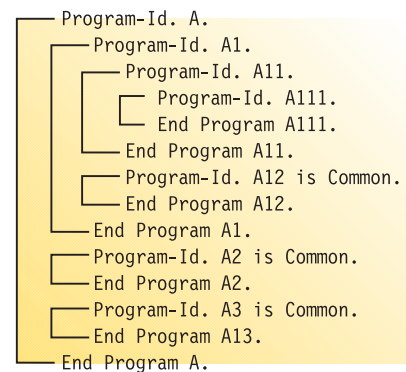

The following table describes the calling hierarchy for the structure that is shown in the example above. Programs A12, A2, and A3 are identified as COMMON, and the calls associated with them differ.

This program	Can call these programs	And can be called by these programs
A	A1, A2, A3	None
A1	A11, A12, A2, A3	A
A11	A111, A12, A2, A3	A1
A111	A12, A2, A3	A11
A12	A2, A3	A1, A11, A111
A2	A3	A, A1, A11, A111, A12, A3
A3	A2	A, A1, A11, A111, A12, A2

In this example, note that:

- A2 cannot call A1 because A1 is not common and is not contained in A2.
- A1 can call A2 because A2 is common.

Scope of names

Names in nested structures are divided into two classes: local and global. The class determines whether a name is known beyond the scope of the program that declares it. A specific search sequence locates the declaration of a name after it is referenced in a program.

Local names:

Names (except the program-name) are local unless declared to be otherwise. Local names are visible or accessible only within the program in which they are declared. They are not visible or accessible to contained and containing programs.

Global names:

A name that is global (indicated by using the GLOBAL clause) is visible and accessible to the program in which it is declared and to all the programs that are directly and indirectly contained in that program. Therefore, the contained programs can share common data and files from the containing program simply by referencing the names of the items.

Any item that is subordinate to a global item (including condition-names and indexes) is automatically global.

You can declare the same name with the GLOBAL clause more than one time, provided that each declaration occurs in a different program. Be aware that you can mask, or hide, a name in a nested structure by having the same name occur in different programs in the same containing structure. However, such masking could cause problems during a search for a name declaration.

Searches for name declarations:

When a name is referenced in a program, a search is made to locate the declaration for that name. The search begins in the program that contains the reference and continues outward to the containing programs until a match is found. The search follows this process:

1. Declarations in the program are searched.

2. If no match is found, only global declarations are searched in successive outer containing programs.
3. The search ends when the first matching name is found. If no match is found, an error exists.

The search is for a global name, not for a particular type of object associated with the name such as a data item or file connector. The search stops when any match is found, regardless of the type of object. If the object declared is of a different type than that expected, an error condition exists.

Making recursive calls

A called program can directly or indirectly execute its caller. For example, program X calls program Y, program Y calls program Z, and program Z then calls program X. This type of call is *recursive*.

To make a recursive call, you must code the RECURSIVE clause in the PROGRAM-ID paragraph of the recursively called program. If you try to recursively call a COBOL program that does not have the RECURSIVE clause in the PROGRAM-ID paragraph, a condition is signaled. If the condition remains unhandled, the run unit will end.

RELATED TASKS

“Identifying a program as recursive” on page 4

RELATED REFERENCES

PROGRAM-ID paragraph (*Enterprise COBOL Language Reference*)

Calling to and from object-oriented programs

When you create applications that contain object-oriented (OO) programs, the OO COBOL programs are DLL programs and can be in one or more dynamic link libraries (DLLs). Each class definition must be in a separate DLL, however.

Calls to or from COBOL DLL programs must either use DLL linkage or be static calls. COBOL dynamic calls to or from COBOL DLL programs are not supported.

If you must call a COBOL DLL program from a COBOL non-DLL program, other means to ensure that the DLL linkage mechanism is followed are available.

Using procedure and function pointers

You can set procedure-pointer and function-pointer data items only by using format 6 of the SET statement.

Procedure pointers are data items defined with the USAGE IS PROCEDURE-POINTER clause. *Function pointers* are data items defined with the USAGE IS FUNCTION-POINTER clause. In this information, “pointer” refers to either a procedure-pointer data item or a function-pointer data item. You can set either of these data items to contain entry addresses of, or pointers to, these entry points:

- Another COBOL program that is not nested. For example, to have a user-written error-handling routine take control when an exception condition occurs, you must first pass the entry address of the routine to CEEHDLR, a condition-management Language Environment callable service, so that the routine is registered.

- A program written in another language. For example, to receive the entry address of a C function, call the function with the CALL RETURNING statement. It will return a pointer that you can either use as a function pointer or convert to a procedure pointer by using a form of the SET statement.
- An alternate entry point in another COBOL program (as defined in an ENTRY statement).

The SET statement sets the pointer to refer either to an entry point in the same program object as your program, to a separate program object, or to an entry point that is exported from a DLL, depending on the DYNAM|NODYNAM and DLL|NODLL compiler options. Therefore, consider these factors when using these pointer data items:

- If you compile a program with the NODYNAM and NODLL options and set a pointer item to a literal value (to an actual name of an entry point), the value must refer to an entry point in the same program object. Otherwise the reference cannot be resolved.
- If you compile a program with the NODLL option and either set a pointer item to an identifier that will contain the name of the entry point at run time or set the pointer item to a literal and compile with the DYNAM option, then the pointer item, whether a literal or variable, must point to an entry point in a separate program objectlink. The entry point can be either the primary entry point or an alternate entry point named in an ALIAS binder (linkage-editor) statement.
- If you compile with the NODYNAM and DLL options and set a pointer item to a literal value (the actual name of an entry point), the value must refer to an entry point in the same program object or to an entry-point name that is exported from a DLL module. In the latter case you must include the DLL side file for the target DLL module in the link-edit of your program object.
- If you compile with the NODYNAM and DLL options and set a pointer item to an identifier (a data item that contains the entry point name at run time), the identifier value must refer to the entry-point name that is exported from a DLL module. In this case the DLL module name must match the name of the exported entry point.

If you set a pointer item to an entry address in a dynamically called program object, and your program subsequently cancels that dynamically called module, then that pointer item becomes undefined. Reference to it thereafter is not reliable.

Procedure pointer and function pointer calls are supported for AMODE 24 applications. However, the addressing mode cannot be switched for these calls, so the called and calling programs must have the same addressing mode at execution time.

COBOL entry points with the AMODE ANY attribute can be entered in either AMODE 31 or AMODE 24. However, the AMODE value that is in effect when the program is entered for the first time must also be in effect for all subsequent reentries of the program during the current Language Environment enclave.

RELATED TASKS

“Deciding which type of pointer to use” on page 489

“Calling alternate entry points” on page 489

“Using procedure or function pointers with DLLs” on page 512

RELATED REFERENCES

“DLL” on page 321

“DYNAM” on page 323

CANCEL statement (*Enterprise COBOL Language Reference*)
Format 6: SET for procedure-pointer and function-pointer data items
(*Enterprise COBOL Language Reference*)
ENTRY statement (*Enterprise COBOL Language Reference*)
MVS Program Management: User's Guide and Reference

Deciding which type of pointer to use

Use procedure pointers to call other COBOL programs and to call Language Environment callable services. Use function pointers to communicate with C/C++ programs or with services provided by the Java Native Interface.

Procedure pointers are more efficient than function pointers for COBOL-to-COBOL calls, and are required for calls to Language Environment condition-handling services.

Many callable services written in C return function pointers. You can call such a C function pointer from your COBOL program by using COBOL function pointers as shown below.

```
IDENTIFICATION DIVISION.  
PROGRAM-ID. DEMO.  
ENVIRONMENT DIVISION.  
DATA DIVISION.  
*  
WORKING-STORAGE SECTION.  
01 FP USAGE FUNCTION-POINTER.  
*  
PROCEDURE DIVISION.  
    CALL "c-function" RETURNING FP.  
    CALL FP.
```

RELATED TASKS

"Using procedure or function pointers with DLLs" on page 512
"Accessing JNI services" on page 633

Calling alternate entry points

Static calls to alternate entry points work without restriction.

Dynamic calls to alternate entry points require the following elements:

- Either explicitly specified NAME or ALIAS binder (linkage-editor) control statements, or use of the NAME compiler option which generates them automatically.
- An intervening CANCEL for any dynamic call to the same module at a different entry point. CANCEL causes the program to be invoked in initial state when it is called at a new entry point.

You can specify another entry point at which a program will begin running by using the ENTRY label in the called program. However, this method is not recommended in a structured program.

"Examples: static and dynamic CALL statements" on page 482

RELATED REFERENCES

"NAME" on page 339
CANCEL statement (*Enterprise COBOL Language Reference*)
ENTRY statement (*Enterprise COBOL Language Reference*)
MVS Program Management: User's Guide and Reference

Making programs reentrant

If more than one user will run an application program at the same time (for example, users in different address spaces accessing a program that resides in the link pack area), you must make the program *reentrant* by compiling with the RENT option.

You do not need to worry about multiple copies of variables. The compiler creates the necessary reentrancy controls in the object module.

The following Enterprise COBOL programs must be reentrant:

- Programs to be used with CICS
- Programs to be preloaded with IMS
- Programs to be used as DB2 stored procedures
- Programs to be run in the z/OS UNIX environment
- Programs that are enabled for DLL support
- Programs that use object-oriented syntax

For reentrant programs, use the DATA compiler option and the HEAP and ALL31 runtime options to control whether dynamic data areas, such as WORKING-STORAGE, are obtained from storage below or above the 16 MB line.

RELATED CONCEPTS

“Storage and its addressability” on page 39

RELATED TASKS

“Compiling programs to create DLLs” on page 508

Chapter 16, “Compiling, linking, and running OO applications,” on page 291

RELATED REFERENCES

“RENT” on page 352

“DATA” on page 318

Language Environment Programming Reference (ALL31, HEAP)

Chapter 25. Sharing data

If a run unit consists of several separately compiled programs that call each other, the programs must be able to communicate with each other. They also usually need access to common data.

This information describes how you can write programs that share data with other programs. In this information, a *subprogram* is any program that is called by another program.

RELATED TASKS

“Using data from another program” on page 16

“Sharing data with Java” on page 637

“Passing data”

“Coding the LINKAGE SECTION” on page 495

“Coding the PROCEDURE DIVISION for passing arguments” on page 496

“Passing return-code information” on page 500

“Sharing data by using the EXTERNAL clause” on page 501

“Sharing files between programs (external files)” on page 501

“Accessing main program parameters under z/OS” on page 505

Passing data

You can choose among three ways of passing data between programs: BY REFERENCE, BY CONTENT, or BY VALUE.

BY REFERENCE

The subprogram refers to and processes the data items in the storage of the calling program rather than working on a copy of the data. BY REFERENCE is the assumed passing mechanism for a parameter if none of the three ways is specified or implied for the parameter.

BY CONTENT

The calling program passes only the contents of the *literal* or *identifier*. The called program cannot change the value of the *literal* or *identifier* in the calling program, even if it modifies the data item in which it received the *literal* or *identifier*.

BY VALUE

The calling program or method passes the value of the *literal* or *identifier*, not a reference to the sending data item. The called program or invoked method can change the parameter. However, because the subprogram or method has access only to a temporary copy of the sending data item, any change does not affect the argument in the calling program.

The following figure shows the differences in values passed BY REFERENCE, BY CONTENT, and BY VALUE:

```

MOVE 16 TO X.
CALL ABC USING
  BY REFERENCE X
  BY CONTENT X
  BY VALUE X
  BY CONTENT ADDRESS OF X

```

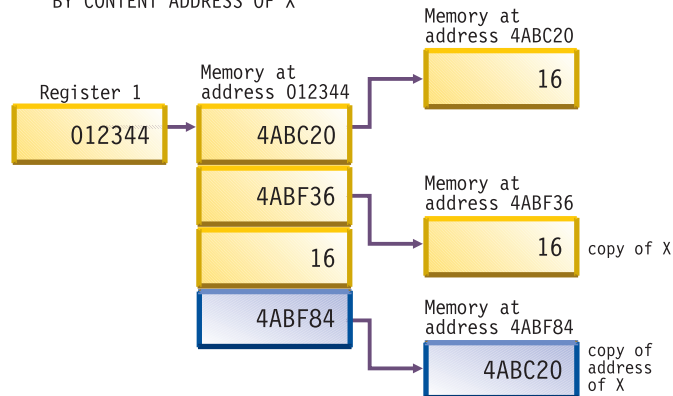

Determine which of these data-passing methods to use based on what you want your program to do with the data.

Table 61. Methods for passing data in the CALL statement

Code	Purpose	Comments
CALL . . . BY REFERENCE <i>identifier</i>	To have the definition of the argument of the CALL statement in the calling program and the definition of the parameter in the called program share the same memory	Any changes made by the subprogram to the parameter affect the argument in the calling program.
CALL . . . BY REFERENCE ADDRESS OF <i>identifier</i>	To pass the address of <i>identifier</i> to a called program, where <i>identifier</i> is an item in the LINKAGE SECTION	Any changes made by the subprogram to the address affect the address in the calling program.
CALL . . . BY REFERENCE <i>file-name</i>	To pass a data control block (DCB) to assembler programs	The file-name must reference a QSAM sequential file. ¹
CALL . . . BY CONTENT ADDRESS OF <i>identifier</i>	To pass a copy of the address of <i>identifier</i> to a called program	Any changes to the copy of the address will not affect the address of <i>identifier</i> , but changes to <i>identifier</i> using the copy of the address will cause changes to <i>identifier</i> .
CALL . . . BY CONTENT <i>identifier</i>	To pass a copy of the identifier to the subprogram	Changes to the parameter by the subprogram will not affect the caller's identifier.
CALL . . . BY CONTENT <i>literal</i>	To pass a copy of a literal value to a called program	
CALL . . . BY CONTENT LENGTH OF <i>identifier</i>	To pass a copy of the length of a data item	The calling program passes the length of the <i>identifier</i> from its LENGTH special register.
A combination of BY REFERENCE and BY CONTENT such as: CALL 'ERRPROC' USING BY REFERENCE A BY CONTENT LENGTH OF A.	To pass both a data item and a copy of its length to a subprogram	
CALL . . . BY VALUE <i>identifier</i>	To pass data to a program, such as a C/C++ program, that uses BY VALUE parameter linkage conventions	A copy of the identifier is passed directly in the parameter list.

Table 61. Methods for passing data in the CALL statement (continued)

Code	Purpose	Comments
CALL . . . BY VALUE <i>literal</i>	To pass data to a program, such as a C/C++ program, that uses BY VALUE parameter linkage conventions	A copy of the literal is passed directly in the parameter list.
CALL . . . BY VALUE ADDRESS OF <i>identifier</i>	To pass the address of <i>identifier</i> to a called program. This is the recommended way to pass data to a C/C++ program that expects a pointer to the data.	Any changes to the copy of the address will not affect the address of <i>identifier</i> , but changes to <i>identifier</i> using the copy of the address will cause changes to <i>identifier</i> .
CALL . . . RETURNING	To call a C/C++ function with a function return value	
<p>1. File-names as CALL operands are allowed as an IBM extension to COBOL. Any use of the extension generally depends on the specific internal implementation of the compiler. Control block field settings might change in future releases. Any changes made to the control block are the user's responsibility and are not supported by IBM.</p>		

RELATED CONCEPTS

"Storage and its addressability" on page 39

RELATED TASKS

"Describing arguments in the calling program"

"Describing parameters in the called program" on page 494

"Testing for OMITTED arguments" on page 495

"Specifying CALL . . . RETURNING" on page 501

"Sharing data by using the EXTERNAL clause" on page 501

"Sharing files between programs (external files)" on page 501

"Sharing data with Java" on page 637

RELATED REFERENCES

CALL statement (*Enterprise COBOL Language Reference*)

The USING phrase (*Enterprise COBOL Language Reference*)

INVOKE statement (*Enterprise COBOL Language Reference*)

Describing arguments in the calling program

In the calling program, describe arguments in the DATA DIVISION in the same manner as other data items in the DATA DIVISION.

Storage for arguments is allocated only in the outermost program. For example, program A calls program B, which calls program C. Data items are allocated in program A. They are described in the LINKAGE SECTION of programs B and C, making the one set of data available to all three programs.

If you reference data in a file, the file must be open when the data is referenced.

Code the USING phrase of the CALL statement to pass the arguments. If you pass a data item BY VALUE, it must be an elementary item.

To pass CALL arguments from AMODE 31 programs to AMODE 24 programs, you must ensure that the arguments are in storage below the 16 MB line to be addressed by the AMODE 24 subprogram.

- For reentrant AMODE 31 programs, compile the program with the DATA(24) option, or specify the Language Environment runtime option HEAP(, ,BELOW) if

WORKING-STORAGE is allocated from HEAP storage. For more information about when WORKING-STORAGE is allocated from HEAP storage, see “Storage and its addressability” on page 39.

- For nonreentrant programs that are compiled with the NORENT option, compile with the RMODE(24) or RMODE(AUTO) option. Consequently, the following items are allocated below the 16 MB line, and can be passed as arguments to AMODE 24 programs:
 - WORKING-STORAGE data items without the EXTERNAL clause
 - FD record areas
 - QSAM buffers
- For mixed AMODE applications, the Language Environment runtime options ALL31(OFF) and STACK(, ,BELOW) are required. Consequently, the LOCAL-STORAGE SECTION data items and data items with the EXTERNAL attributes will be allocated below the 16 MB line, and can be passed as arguments to AMODE 24 programs.

RELATED CONCEPTS

“Storage and its addressability” on page 39

RELATED TASKS

“Coding the LINKAGE SECTION” on page 495

“Coding the PROCEDURE DIVISION for passing arguments” on page 496

RELATED REFERENCES

The USING phrase (*Enterprise COBOL Language Reference*)

Describing parameters in the called program

You must know what data is being passed from the calling program and describe it in the LINKAGE SECTION of each program that is called directly or indirectly by the calling program.

Code the USING phrase after the PROCEDURE DIVISION header to name the parameters that receive the data that is passed from the calling program.

When arguments are passed to the subprogram BY REFERENCE, it is invalid for the subprogram to specify any relationship between its parameters and any fields other than those that are passed and defined in the main program. The subprogram must not:

- Define a parameter to be larger in total number of bytes than the corresponding argument.
- Use subscript references to refer to elements beyond the limits of tables that are passed as arguments by the calling program.
- Use reference modification to access data beyond the length of defined parameters.
- Manipulate the address of a parameter in order to access other data items that are defined in the calling program.

If any of the rules above are violated, unexpected results might occur.

RELATED TASKS

“Coding the LINKAGE SECTION” on page 495

RELATED REFERENCES

The USING phrase (*Enterprise COBOL Language Reference*)

Testing for OMITTED arguments

You can specify that one or more BY REFERENCE arguments are not to be passed to a called program by coding the OMITTED keyword in place of those arguments in the CALL statement.

For example, to omit the second argument when calling program sub1, code this statement:

```
Call 'sub1' Using PARM1, OMITTED, PARM3
```

The arguments in the USING phrase of the CALL statement must match the parameters of the called program in number and position.

In a called program, you can test whether an argument was passed as OMITTED by comparing the address of the corresponding parameter to NULL. For example:

```
Program-ID. sub1.  
.  
.  
Procedure Division Using RPARAM1, RPARAM2, RPARAM3.  
  If Address Of RPARAM2 = Null Then  
    Display 'No 2nd argument was passed this time'  
  Else  
    Perform Process-Param-2  
  End-If
```

RELATED REFERENCES

CALL statement (*Enterprise COBOL Language Reference*)

The USING phrase (*Enterprise COBOL Language Reference*)

Coding the LINKAGE SECTION

Code the same number of data-names in the identifier list of the called program as the number of arguments in the calling program. Synchronize by position, because the compiler passes the first argument from the calling program to the first identifier of the called program, and so on.

You will introduce errors if the number of data-names in the identifier list of a called program is greater than the number of arguments passed from the calling program. The compiler does not try to match arguments and parameters.

The following figure shows a data item being passed from one program to another (implicitly BY REFERENCE):

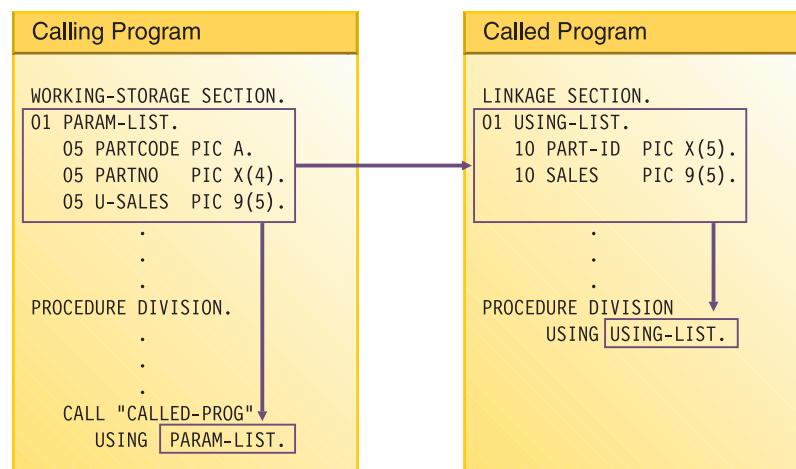

In the calling program, the code for parts (PARTCODE) and the part number (PARTNO) are distinct data items. In the called program, by contrast, the code for parts and the part number are combined into one data item (PART-ID). In the called program, a reference to PART-ID is the only valid reference to these items.

RELATED TASKS

“Accessing main program parameters under z/OS” on page 505

Coding the PROCEDURE DIVISION for passing arguments

If you pass an argument BY VALUE, code the USING BY VALUE clause in the PROCEDURE DIVISION header of the subprogram. If you pass an argument BY REFERENCE or BY CONTENT, you do not need to indicate in the header how the argument was passed.

```
PROCEDURE DIVISION USING BY VALUE. . .  
PROCEDURE DIVISION USING. . .  
PROCEDURE DIVISION USING BY REFERENCE. . .
```

The first header above indicates that the data items are passed BY VALUE; the second or third headers indicate that the items are passed BY REFERENCE or BY CONTENT.

RELATED REFERENCES

The procedure division header (*Enterprise COBOL Language Reference*)

The USING phrase (*Enterprise COBOL Language Reference*)

CALL statement (*Enterprise COBOL Language Reference*)

Grouping data to be passed

Consider grouping all the data items that you need to pass between programs and putting them under one level-01 item. If you do so, you can pass a single level-01 record.

Note that if you pass a data item BY VALUE, it must be an elementary item.

To lessen the possibility of mismatched records, put the level-01 record into a copy library and copy it into both programs. That is, copy it in the WORKING-STORAGE SECTION of the calling program and in the LINKAGE SECTION of the called program.

RELATED TASKS

“Coding the LINKAGE SECTION” on page 495

RELATED REFERENCES

CALL statement (*Enterprise COBOL Language Reference*)

Handling null-terminated strings

COBOL supports null-terminated strings when you use string-handling verbs together with null-terminated literals and the hexadecimal literal X'00'.

You can manipulate null-terminated strings (passed from a C program, for example) by using string-handling mechanisms such as those in the following code:

```
01 L      pic X(20) value z'ab'.  
01 M      pic X(20) value z'cd'.  
01 N      pic X(20).  
01 N-Length pic 99 value zero.  
01 Y      pic X(13) value 'Hello, World!'.
```

To determine the length of a null-terminated string, and display the value of the string and its length, code:

```
Inspect N tallying N-length for characters before initial X'00'  
Display 'N: ' N(1:N-length) ' Length: ' N-length
```

To move a null-terminated string to an alphanumeric string, but delete the null, code:

```
Unstring N delimited by X'00' into X
```

To create a null-terminated string, code:

```
String Y delimited by size  
X'00' delimited by size  
into N.
```

To concatenate two null-terminated strings, code:

```
String L delimited by x'00'  
M delimited by x'00'  
X'00' delimited by size  
into N.
```

RELATED TASKS

“Manipulating null-terminated strings” on page 110

RELATED REFERENCES

Null-terminated alphanumeric literals (*Enterprise COBOL Language Reference*)

Using pointers to process a chained list

When you need to pass and receive addresses of record areas, you can use pointer data items, which are either data items that are defined with the `USAGE IS POINTER` clause or are `ADDRESS OF` special registers.

A typical application for using pointer data items is in processing a *chained list*, a series of records in which each record points to the next.

When you pass addresses between programs in a chained list, you can use `NULL` to assign the value of an address that is not valid (nonnumeric 0) to a pointer item in either of two ways:

- Use a `VALUE IS NULL` clause in its data definition.
- Use `NULL` as the sending field in a `SET` statement.

In the case of a chained list in which the pointer data item in the last record contains a null value, you can use this code to check for the end of the list:

```
IF PTR-NEXT-REC = NULL  
  . . .  
  (logic for end of chain)
```

If the program has not reached the end of the list, the program can process the record and move on to the next record.

The data passed from a calling program might contain header information that you want to ignore. Because pointer data items are not numeric, you cannot directly perform arithmetic on them. However, to bypass header information, you can use the `SET` statement to increment the passed address.

“Example: using pointers to process a chained list” on page 498

RELATED TASKS

“Coding the LINKAGE SECTION” on page 495

“Coding the PROCEDURE DIVISION for passing arguments” on page 496

RELATED REFERENCES

SET statement (*Enterprise COBOL Language Reference*)

Example: using pointers to process a chained list

The following example shows how you might process a linked list, that is, a chained list of data items.

For this example, picture a chained list of data that consists of individual salary records. The following figure shows one way to visualize how the records are linked in storage. The first item in each record except the last points to the next record. The first item in the last record contains a null value (instead of a valid address) to indicate that it is the last record.

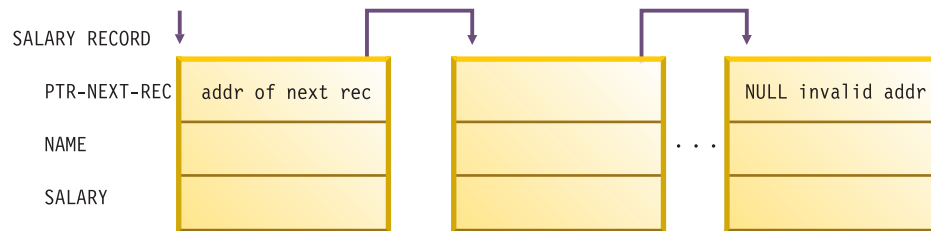

The high-level pseudocode for an application that processes these records might be:

```

Obtain address of first record in chained list from routine
Check for end of the list
Do until end of the list
  Process record
  Traverse to the next record
End

```

The following code contains an outline of the calling program, LISTS, used in this example of processing a chained list.

```

IDENTIFICATION DIVISION.
PROGRAM-ID. LISTS.
ENVIRONMENT DIVISION.
DATA DIVISION.
*****
WORKING-STORAGE SECTION.
77 PTR-FIRST          POINTER VALUE IS NULL.          (1)
77 DEPT-TOTAL         PIC 9(4) VALUE IS 0.
*****
LINKAGE SECTION.
01 SALARY-REC.
   02 PTR-NEXT-REC    POINTER.                        (2)
   02 NAME            PIC X(20).
   02 DEPT            PIC 9(4).
   02 SALARY          PIC 9(6).
01 DEPT-X            PIC 9(4).
*****
PROCEDURE DIVISION USING DEPT-X.
*****
* FOR EVERYONE IN THE DEPARTMENT RECEIVED AS DEPT-X,
* GO THROUGH ALL THE RECORDS IN THE CHAINED LIST BASED ON THE
* ADDRESS OBTAINED FROM THE PROGRAM CHAIN-ANCH
* AND ACCUMULATE THE SALARIES.
* IN EACH RECORD, PTR-NEXT-REC IS A POINTER TO THE NEXT RECORD

```

```

* IN THE LIST; IN THE LAST RECORD, PTR-NEXT-REC IS NULL.
* DISPLAY THE TOTAL.
*****
      CALL "CHAIN-ANCH" USING PTR-FIRST           (3)
      SET ADDRESS OF SALARY-REC TO PTR-FIRST      (4)
*****
      PERFORM WITH TEST BEFORE UNTIL ADDRESS OF SALARY-REC = NULL (5)

      IF DEPT = DEPT-X
        THEN ADD SALARY TO DEPT-TOTAL
        ELSE CONTINUE
      END-IF
      SET ADDRESS OF SALARY-REC TO PTR-NEXT-REC   (6)

      END-PERFORM
*****
      DISPLAY DEPT-TOTAL
      GOBACK.

```

- (1) PTR-FIRST is defined as a pointer data item with an initial value of NULL. On a successful return from the call to CHAIN-ANCH, PTR-FIRST contains the address of the first record in the chained list. If something goes wrong with the call, and PTR-FIRST never receives the value of the address of the first record in the chain, a null value remains in PTR-FIRST and, according to the logic of the program, the records will not be processed.
- (2) The LINKAGE SECTION of the calling program contains the description of the records in the chained list. It also contains the description of the department code that is passed in the USING clause of the CALL statement.
- (3) To obtain the address of the first SALARY-REC record area, the LISTS program calls the program CHAIN-ANCH.
- (4) The SET statement bases the record description SALARY-REC on the address contained in PTR-FIRST.
- (5) The chained list in this example is set up so that the last record contains an address that is not valid. This check for the end of the chained list is accomplished with a do-while structure where the value NULL is assigned to the pointer data item in the last record.
- (6) The address of the record in the LINKAGE-SECTION is set equal to the address of the next record by means of the pointer data item sent as the first field in SALARY-REC. The record-processing routine repeats, processing the next record in the chained list.

To increment addresses received from another program, you could set up the LINKAGE SECTION and PROCEDURE DIVISION like this:

```

LINKAGE SECTION.
01 RECORD-A.
   02 HEADER          PIC X(12).
   02 REAL-SALARY-REC PIC X(30).
. . .
01 SALARY-REC.
   02 PTR-NEXT-REC    POINTER.
   02 NAME            PIC X(20).
   02 DEPT            PIC 9(4).
   02 SALARY          PIC 9(6).
. . .
PROCEDURE DIVISION USING DEPT-X.
. . .
      SET ADDRESS OF SALARY-REC TO ADDRESS OF REAL-SALARY-REC

```

The address of SALARY-REC is now based on the address of REAL-SALARY-REC, or RECORD-A + 12.

RELATED TASKS

“Using pointers to process a chained list” on page 497

Passing return-code information

Use the RETURN-CODE special register to pass return codes between programs. (Methods do not return information in the RETURN-CODE special register, but they can check the register after a call to a program.)

You can also use the RETURNING phrase in the PROCEDURE DIVISION header of a method to return information to an invoking program or method. If you use PROCEDURE DIVISION . . . RETURNING with CALL . . . RETURNING, the RETURN-CODE register will not be set.

Using the RETURN-CODE special register

When a COBOL program returns to its caller, the contents of the RETURN-CODE special register are stored into register 15.

When control is returned to a COBOL program or method from a call, the contents of register 15 are stored into the RETURN-CODE special register of the calling program or method. When control is returned from a COBOL program to the operating system, the special register contents are returned as a user return code.

You might need to think about this handling of the RETURN-CODE special register when control is returned to a COBOL program from a non-COBOL program. If the non-COBOL program does not use register 15 to pass back the return code, the RETURN-CODE special register of the COBOL program might be updated with an invalid value. Unless you set this special register to a meaningful value before your Enterprise COBOL program returns to the operating system, a return code that is invalid will be passed to the system.

For equivalent function between COBOL and C programs, have your COBOL program call the C program with the RETURNING phrase. If the C program (function) correctly declares a function value, the RETURNING value of the calling COBOL program will be set.

You cannot set the RETURN-CODE special register by using the INVOKE statement.

Using PROCEDURE DIVISION RETURNING . . .

Use the RETURNING phrase in the PROCEDURE DIVISION header of a program to return information to the calling program.

```
PROCEDURE DIVISION RETURNING dataname2
```

When the called program in the example above successfully returns to its caller, the value in *dataname2* is stored into the identifier that was specified in the RETURNING phrase of the CALL statement:

```
CALL . . . RETURNING dataname2
```

CEEPIPI: The results of specifying PROCEDURE DIVISION RETURNING in programs that are called with the Language Environment preinitialization service (CEEPIPI) are undefined.

Specifying CALL . . . RETURNING

You can specify the RETURNING phrase of the CALL statement for calls to C/C++ functions or to COBOL subroutines.

The RETURNING phrase has the following format.

```
CALL . . . RETURNING dataname2
```

The return value of the called program is stored into *dataname2*. You must define *dataname2* in the DATA DIVISION of the calling program. The data type of the return value that is declared in the target function must be identical to the data type of *dataname2*.

Sharing data by using the EXTERNAL clause

Use the EXTERNAL clause to enable separately compiled programs and methods (including programs in a batch sequence) to share data items. Code EXTERNAL in the level-01 data description in the WORKING-STORAGE SECTION.

The following rules apply:

- Items that are subordinate to an EXTERNAL group item are themselves EXTERNAL.
- You cannot use the name of an EXTERNAL data item as the name for another EXTERNAL item in the same program.
- You cannot code the VALUE clause for any group item or subordinate item that is EXTERNAL.

In the run unit, any COBOL program or method that has the same data description for the item as the program that contains the item can access and process that item. For example, suppose program A has the following data description:

```
01 EXT-ITEM1    EXTERNAL    PIC 99.
```

Program B can access that data item if B has the identical data description in its WORKING-STORAGE SECTION.

Any program that has access to an EXTERNAL data item can change the value of that item. Therefore do not use this clause for data items that you need to protect.

Sharing files between programs (external files)

To enable separately compiled programs or methods in a run unit to access a file as a common file, use the EXTERNAL clause for the file.

It is recommended that you follow these guidelines:

- Use the same data-name in the FILE STATUS clause of all the programs that check the file status code.
- For each program that checks the same file status field, code the EXTERNAL clause in the level-01 data definition for the file status field.

Using an external file has these benefits:

- Even if the main program does not contain any input or output statements, it can reference the record area of the file.
- Each subprogram can control a single input or output function, such as OPEN or READ.
- Each program has access to the file.

“Example: using external files”

RELATED TASKS

“Using data in input and output operations” on page 11

RELATED REFERENCES

EXTERNAL clause (*Enterprise COBOL Language Reference*)

Example: using external files

The following example shows the use of an external file in several programs. COPY statements ensure that each subprogram contains an identical description of the file.

The following table describes the main program and subprograms.

Name	Function
ef1	The main program, which calls all the subprograms and then verifies the contents of a record area
ef1openo	Opens the external file for output and checks the file status code
ef1write	Writes a record to the external file and checks the file status code
ef1openi	Opens the external file for input and checks the file status code
ef1read	Reads a record from the external file and checks the file status code
ef1close	Closes the external file and checks the file status code

Each program uses three copybooks:

- efselect is placed in the FILE-CONTROL paragraph:
Select ef1
Assign To ef1
File Status Is efs1
Organization Is Sequential.
- effile is placed in the FILE SECTION:
Fd ef1 Is External
 Record Contains 80 Characters
 Recording Mode F.
01 ef-record-1.
 02 ef-item-1 Pic X(80).
- efwrkstg is placed in the WORKING-STORAGE SECTION:
01 efs1 Pic 99 External.

Input/output using external files

```
IDENTIFICATION DIVISION.  
Program-Id.  
    ef1.  
*  
* This main program controls external file processing.  
*  
ENVIRONMENT DIVISION.  
Input-Output Section.  
File-Control.  
    Copy efselect.  
DATA DIVISION.  
FILE SECTION.  
    Copy effile.  
WORKING-STORAGE SECTION.  
    Copy efwrkstg.
```

```

PROCEDURE DIVISION.
  Call "eflopeno"
  Call "eflwrite"
  Call "eflclose"
  Call "eflopeni"
  Call "eflread"
  If ef-record-1 = "First record" Then
    Display "First record correct"
  Else
    Display "First record incorrect"
    Display "Expected: " "First record"
    Display "Found   : " ef-record-1
  End-If
  Call "eflclose"
  Goback.
End Program ef1.
IDENTIFICATION DIVISION.
Program-Id.
  eflopeno.
*
* This program opens the external file for output.
*
ENVIRONMENT DIVISION.
Input-Output Section.
File-Control.
  Copy efselect.
DATA DIVISION.
FILE SECTION.
  Copy effile.
WORKING-STORAGE SECTION.
  Copy efwrkstg.
PROCEDURE DIVISION.
  Open Output ef1
  If efs1 Not = 0
    Display "file status " efs1 " on open output"
    Stop Run
  End-If
  Goback.
End Program eflopeno.
IDENTIFICATION DIVISION.
Program-Id.
  eflwrite.
*
* This program writes a record to the external file.
*
ENVIRONMENT DIVISION.
Input-Output Section.
File-Control.
  Copy efselect.
DATA DIVISION.
FILE SECTION.
  Copy effile.
WORKING-STORAGE SECTION.
  Copy efwrkstg.
PROCEDURE DIVISION.
  Move "First record" to ef-record-1
  Write ef-record-1
  If efs1 Not = 0
    Display "file status " efs1 " on write"
    Stop Run
  End-If
  Goback.
End Program eflwrite.
Identification Division.
Program-Id.
  eflopeni.
*

```

```

* This program opens the external file for input.
*
ENVIRONMENT DIVISION.
Input-Output Section.
File-Control.
    Copy efselect.
DATA DIVISION.
FILE SECTION.
    Copy effile.
WORKING-STORAGE SECTION.
    Copy efwrkstg.
PROCEDURE DIVISION.
    Open Input ef1
    If efs1 Not = 0
        Display "file status " efs1 " on open input"
        Stop Run
    End-If
    Goback.
End Program eflopeni.
Identification Division.
Program-Id.
    eflread.
*
* This program reads a record from the external file.
*
ENVIRONMENT DIVISION.
Input-Output Section.
File-Control.
    Copy efselect.
DATA DIVISION.
FILE SECTION.
    Copy effile.
WORKING-STORAGE SECTION.
    Copy efwrkstg.
PROCEDURE DIVISION.
    Read ef1
    If efs1 Not = 0
        Display "file status " efs1 " on read"
        Stop Run
    End-If
    Goback.
End Program eflread.
Identification Division.
Program-Id.
    eflclose.
*
* This program closes the external file.
*
ENVIRONMENT DIVISION.
Input-Output Section.
File-Control.
    Copy efselect.
DATA DIVISION.
FILE SECTION.
    Copy effile.
WORKING-STORAGE SECTION.
    Copy efwrkstg.
PROCEDURE DIVISION.
    Close ef1
    If efs1 Not = 0
        Display "file status " efs1 " on close"
        Stop Run
    End-If
    Goback.
End Program eflclose.

```

Accessing main program parameters under z/OS

When you run an Enterprise COBOL program under z/OS and pass the program a parameter string, for example, by using JCL or a TSO command, the parameter list consists of a character string that has a halfword prefix that contains the string length.

You can access the parameter string by using a LINKAGE SECTION and standard COBOL coding as shown in the example referenced below:

“Example: accessing main program parameters under z/OS”

Alternatively, you can obtain the parameter string by calling either of the following Language Environment callable services, which are described in the related references below:

- CEE3PRM (query parameter string): obtain the parameter string (if not longer than 80 characters)
- CEE3PR2 (query parameter string long): obtain the parameter string and its length

In either case, the parameter string might contain program arguments, runtime options, or both. The setting of the CBLOPTS runtime option determines the relative order in which program arguments and runtime options are expected. If CBLOPTS(ON) (the default) is in effect, and program arguments and runtime options are both passed in the parameter string, they must appear in the following order, separated by a forward slash:

program_arguments/runtime_options

For further details, see the related information referenced below.

RELATED TASKS

“Coding the LINKAGE SECTION” on page 495

“Accessing main program parameters under z/OS UNIX” on page 468

Language Environment Programming Guide (Specifying runtime options and program arguments, Preparing your main routine to receive parameters)

RELATED REFERENCES

Language Environment Customization (CBLOPTS (COBOL only))

Language Environment Programming Reference (CEE3PRM, CEE3PR2)

Example: accessing main program parameters under z/OS

The following example shows how to receive a parameter string that is passed to a COBOL program that runs under z/OS, and shows the coding that you can use to access the parameter string.

```
IDENTIFICATION DIVISION.  
PROGRAM-ID. "testarg".  
*  
ENVIRONMENT DIVISION.  
CONFIGURATION SECTION.  
*  
DATA DIVISION.  
WORKING-STORAGE SECTION.  
*  
  linkage section.  
  01  os-parm.  
      05  parm-len          pic s999 comp.  
      05  parm-string.
```

```

        10 parm-char    pic x occurs 0 to 100 times
                        depending on parm-len.
*
PROCEDURE DIVISION using os-parm.
  display "parm-len=" parm-len
  display "parm-string=" parm-string ""
  evaluate parm-string
    when "01" display "case one"
    when "02" display "case two"
    when "95" display "case ninety-five"
    when other display "case unknown"
  end-evaluate
GOBACK.

```

Suppose that the CBLOPTS(ON) runtime option is in effect, and that you pass the following argument in the JCL or TSO command that you use to run the program:

```
'95/'
```

Then the resulting output is:

```

parm-len=002
parm-string='95'
case ninety-five

```

Chapter 26. Creating a DLL or a DLL application

Creating a dynamic link library (DLL) or a DLL application is similar to creating a regular COBOL application. It involves writing, compiling, and linking your source code.

Special considerations when writing a DLL or a DLL application include:

- Determining how the parts of the program object or the application relate to each other or to other DLLs
- Deciding what linking or calling mechanisms to use

Depending on whether you want to create a DLL program object or a program object that references a separate DLL, you need to use slightly different compiler and binder (linkage-editor) options.

RELATED CONCEPTS

“Dynamic link libraries (DLLs)”

RELATED TASKS

“Creating a DLL under z/OS UNIX” on page 286

“Compiling programs to create DLLs” on page 508

“Linking DLLs” on page 509

“Using CALL identifier with DLLs” on page 510

“Using DLL linkage and dynamic calls together” on page 512

“Using COBOL DLLs with C/C++ programs” on page 515

“Using DLLs in OO COBOL applications” on page 516

“Using procedure or function pointers with DLLs” on page 512

Dynamic link libraries (DLLs)

A DLL is a program object that can be accessed from other separate program objects.

A DLL differs from a traditional program object in that it *exports* definitions of programs, functions, or variables to DLLs, DLL applications, or non-DLLs. Therefore, you do not need to link the target routines into the same program object as the referencing routine. When an application references a separate DLL for the first time, the system automatically loads the DLL into memory. In other words, calling a program in a DLL is similar to calling a program object with a dynamic CALL.

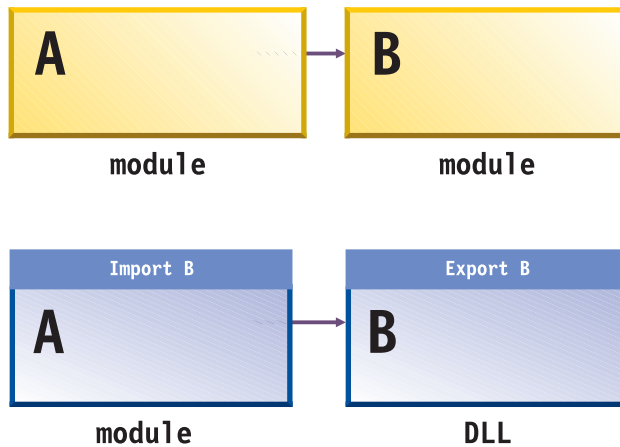

A DLL application is an application that references imported definitions of programs, functions, or variables.

Although some functions of z/OS DLLs overlap the functions provided by COBOL dynamic CALL statements, DLLs have several advantages over regular z/OS program objects and dynamic calls:

- DLLs are common across COBOL and C/C++, thus providing better interoperation for applications that use multiple programming languages. Reentrant COBOL and C/C++ DLLs can also interoperate smoothly.
- You can make calls to programs in separate DLL modules that have long program-names. (Dynamic call resolution truncates program-names to eight characters.) Using the COBOL option PGMNAME(LONGUPPER) or PGMNAME(LONGMIXED) and the COBOL DLL support, you can make calls between program objects with names of up to 160 characters.

DLLs are supported by IBM z/OS Language Environment, based on function provided by the z/OS program management binder. DLL support is available for applications running under z/OS in batch or in TSO, CICS, z/OS UNIX, or IMS environments.

RELATED REFERENCES

“PGMNAME” on page 348

MVS Program Management: User's Guide and Reference (Binder support for DLLs)

Compiling programs to create DLLs

When you compile a COBOL program with the DLL option, it becomes enabled for DLL support. Applications that use DLL support must be reentrant. Therefore, you must compile them with the RENT compiler option and link them with the RENT binder option.

In an application with DLL support, use the following compiler options depending on where the programs or classes are:

Table 62. Compiler options for DLL applications

Programs or classes in:	Compile with:
Root program object	DLL, RENT, NOEXPORTALL
DLL program objects used by other program objects	DLL, RENT, EXPORTALL

If a DLL program object includes some programs that are used only from within the DLL module, you can hide these routines by compiling them with NOEXPORTALL.

“Example: sample JCL for a procedural DLL application” on page 510

RELATED TASKS

“Creating a DLL under z/OS UNIX” on page 286

“Linking DLLs”

Chapter 26, “Creating a DLL or a DLL application,” on page 507

RELATED REFERENCES

“DLL” on page 321

“EXPORTALL” on page 326

“RENT” on page 352

Linking DLLs

You can link DLL-enabled object modules into separate DLL program objects, or you can link them together statically. You can decide whether to package the application as one module or as several DLL modules at link time.

The DLL support in the z/OS binder is recommended for linking DLL applications. The binder can directly receive the output of COBOL compilers.

A binder-based DLL must reside in a PDSE or in a z/OS UNIX file rather than in a PDS.

When using the binder to link a DLL application, use the following options:

Table 63. Binder options for DLL applications

Type of code	Link using binder parameters:
DLL applications	DYNAM(DLL), RENT
Applications that use mixed-case exported program-names	CASE(MIXED)
Class definitions or INVOKE statements	

You must specify a SYSDEFS DD statement to indicate the data set in which the binder should create a DLL definition side file. This side file contains IMPORT control statements for each symbol exported by a DLL. The binder SYSLIN input (the binding code that references the DLL code) must include the DLL definition side files for DLLs that are to be referenced from the module being linked.

If there are programs in the module that you do not want to make available with DLL linkage, you can edit the definition side file to remove these programs.

“Example: sample JCL for a procedural DLL application” on page 510

RELATED TASKS

“Creating a DLL under z/OS UNIX” on page 286

Chapter 26, “Creating a DLL or a DLL application,” on page 507

“Compiling programs to create DLLs” on page 508

RELATED REFERENCES

MVS Program Management: User's Guide and Reference (Binder support for DLLs)

Example: sample JCL for a procedural DLL application

The following example shows how to create an application that consists of a main program that calls a DLL subprogram.

The first step creates the DLL program object that contains the subprogram DemoDLLSubprogram. The second step creates the main program object that contains the program MainProgram. The third step runs the application.

```
//DILLSAMP JOB ,
// TIME=(1),MSGLEVEL=(1,1),MSGCLASS=H,CLASS=A,
// NOTIFY=&SYSUID,USER=&SYSUID
// SET LEPFX='SYS1'
/*-----
/* Compile COBOL subprogram, bind to form a DLL.
/*-----
//STEP1 EXEC IGYWCL,REGION=80M,GOPGM=DEMDDL,
// PARM.COBOL='RENT,PGMN(LM),DLL,EXPORTALL',
// PARM.LKED='RENT,LIST,XREF,LET,MAP,DYNAM(DLL),CASE(MIXED)'
//COBOL.SYSIN DD *
    Identification division.
    Program-id. "DemoDLLSubprogram".
    Procedure division.
        Display "Hello from DemoDLLSubprogram!".
    End program "DemoDLLSubprogram".
/*
//LKED.SYSDEFSD DD DSN=&&SIDEDECK,UNIT=SYSDA,DISP=(NEW,PASS),
// SPACE=(TRK,(1,1))
//LKED.SYSLMOD DD DSN=&&GOSET(&GOPGM),DSNTYPE=LIBRARY,DISP=(MOD,PASS)
//LKED.SYSIN DD DUMMY
/*-----
/* Compile and bind COBOL main program
/*-----
//STEP2 EXEC IGYWCL,REGION=80M,GOPGM=MAINPGM,
// PARM.COBOL='RENT,PGMNAME(LM),DLL',
// PARM.LKED='RENT,LIST,XREF,LET,MAP,DYNAM(DLL),CASE(MIXED)'
//COBOL.SYSIN DD *
    Identification division.
    Program-id. "MainProgram".
    Procedure division.
        Call "DemoDLLSubprogram"
        Stop Run.
    End program "MainProgram".
/*
//LKED.SYSIN DD DSN=&&SIDEDECK,DISP=(OLD,DELETE)
/*-----
/* Execute the main program, calling the subprogram DLL.
/*-----
//STEP3 EXEC PGM=MAINPGM,REGION=80M
//STEPLIB DD DSN=&&GOSET,DISP=(OLD,DELETE)
// DD DSN=&LEPFX..SCEERUN,DISP=SHR
// DD DSN=&LEPFX..SCEERUN2,DISP=SHR
//SYSOUT DD SYSOUT=*
//CEEDUMP DD SYSOUT=*
```

Using CALL identifier with DLLs

In a COBOL program that has been compiled with the DLL option, you can use CALL *identifier* and CALL *literal* statements to make calls to DLLs. However, there are a few additional considerations for the CALL *identifier* case.

For the content of the *identifier* or for the *literal*, use the name of either of the following programs:

- A nested program in the same compilation unit that is eligible to be called from the program that contains the CALL *identifier* statement.
- A program in a separately bound DLL module. The target program-name must be exported from the DLL, and the DLL module name must match the exported name of the target program.

In the nonnested case, the runtime environment interprets the program-name in the *identifier* according to the setting of the PGMNAME compiler option of the program that contains the CALL statement, and interprets the program-name that is exported from the target DLL according to the setting of the PGMNAME option used when the target program was compiled.

The search for the target DLL in the z/OS UNIX file system is case sensitive. If the target DLL is a PDS or PDSE member, the DLL member name must be eight characters or less. For the purpose of the search for the DLL as a PDS or PDSE member, the run time automatically converts the name to uppercase.

If the runtime environment cannot resolve the CALL statement in either of these cases, control is transferred to the ON EXCEPTION or ON OVERFLOW phrase of the CALL statement. If the CALL statement does not specify one of these phrases in this situation, Language Environment raises a severity-3 condition.

RELATED TASKS

- “Using DLL linkage and dynamic calls together” on page 512
- “Compiling programs to create DLLs” on page 508
- “Linking DLLs” on page 509

RELATED REFERENCES

- “DLL” on page 321
- “PGMNAME” on page 348
- CALL statement (*Enterprise COBOL Language Reference*)
- “Search order for DLLs in the z/OS UNIX file system”

Search order for DLLs in the z/OS UNIX file system

When you use the z/OS UNIX file system, the search order for resolving a DLL reference in a CALL statement depends on the setting of the Language Environment POSIX runtime option.

If the POSIX runtime option is ON, the search order is as follows:

1. The runtime environment looks for the DLL in the z/OS UNIX file system. If the LIBPATH environment variable is set, the run time searches each directory listed. Otherwise, it searches just the current directory. The search for the DLL in the z/OS UNIX file system is case sensitive.
2. If the runtime environment does not find the DLL in the z/OS UNIX file system, it tries to load the DLL from the MVS load library search order of the caller. In this case, the DLL name must be eight characters or less. The run time automatically converts the DLL name to uppercase for this search.

If the POSIX runtime option is set to OFF, the search order is reversed:

1. The runtime environment tries to load the DLL from the search order for the load library of the caller.
2. If the runtime environment cannot load the DLL from this load library, it tries to load the DLL from the z/OS UNIX file system.

RELATED TASKS

“Using CALL identifier with DLLs” on page 510

RELATED REFERENCES

Language Environment Programming Reference (POSIX)

Using DLL linkage and dynamic calls together

For applications (that is, Language Environment enclaves) that are structured as multiple separately bound modules, each module can be invoked by using dynamic call linkage or DLL linkage. For a certain module, use exclusively one form of linkage to enter it. However, the caller can contain CALL statements with both linkage types, calling out to different modules.

DLL linkage refers to a call in a program that is compiled with the DLL and NODYNAM options, or a call with the CALLINTERFACE compiler directive that specifies DLL. In such calls, the called subprogram is resolved to an exported name in a separate module. DLL linkage can also refer to an invocation of a method that is defined in a separate module.

Within a compilation unit you can call a specific program with only one of the calling conventions: Dynamic, DLL or Static. If a program is called by using different calling conventions, the compiler diagnoses this case and force all the calls to have the same convention as the first call statement that is encountered for that program.

A program can contain CALL statements with both dynamic call linkage and DLL linkage. It can do so by using the CALLINTERFACE compiler directive to specify the linkage type of a particular call. All components of a DLL application must have the same AMODE. The automatic AMODE switching normally provided by COBOL dynamic calls is not available for DLL linkages. You cannot cancel programs that are called by using DLL linkage.

All components of a DLL application must have the same AMODE. The automatic AMODE switching normally provided by COBOL dynamic calls is not available for DLL linkages.

RELATED CONCEPTS

“Dynamic link libraries (DLLs)” on page 507

RELATED TASKS

“Compiling programs to create DLLs” on page 508

“Linking DLLs” on page 509

“Using procedure or function pointers with DLLs”

“Calling DLLs from non-DLLs” on page 513

RELATED REFERENCES

“DLL” on page 321

“EXPORTALL” on page 326

CALLINTERFACE (*Enterprise COBOL Language Reference*)

Using procedure or function pointers with DLLs

In run units that contain both DLLs and non-DLLs, use procedure- and function-pointer data items with care.

The SET *procedure-pointer-1* TO ENTRY *entry-name* statement, SET *function-pointer-1* TO ENTRY *entry-name* statement, and the CALL statement have a call linkage type that associates with them. The call linkage type is determined by the compiler options and the CALLINTERFACE directive that are in effect on that statement. In a program that is compiled with the DLL option, the default call linkage type is DLL. Otherwise, the linkage type is non-DLL. This default can be overridden by the CALLINTERFACE directive.

For a procedure-pointer or function-pointer data item that is set by a SET statement with linkage type non-DLL, it must not be used by a CALL statement with linkage type DLL. For a SET statement with linkage type DLL and the *entry-name* is an identifier, and if the NODYNAM option is in effect, the *entry-name* identifier value must refer to the entry-point name that is exported from a DLL module. The DLL module name must match the name of the exported entry point. In this case, note also that:

- The program-name that is contained in the identifier is interpreted according to the setting of the PGMNAME (COMPAT|LONGUPPER|LONGMIXED) compiler option of the program that contains the CALL statement.
- The program-name that is exported from the target DLL is interpreted according to the setting of the PGMNAME option used when compiling the target program.
- The search for the target DLL in the z/OS UNIX file system is case sensitive.
- If the target DLL is a PDS or PDSE member, the DLL member name must have eight characters or less. For the purpose of the search for the DLL as a PDS or PDSE member, the name is automatically converted to uppercase.

RELATED TASKS

“Using CALL identifier with DLLs” on page 510

“Using procedure and function pointers” on page 487

“Compiling programs to create DLLs” on page 508

“Linking DLLs” on page 509

RELATED REFERENCES

“DLL” on page 321

“EXPORTALL” on page 326

CALLINTERFACE (*Enterprise COBOL Language Reference*)

Calling DLLs from non-DLLs

It is possible to call a DLL from a COBOL program that is compiled with the NODLL option, but there are restrictions.

You can use the following methods to ensure that the DLL linkage is followed:

- Put the COBOL DLL programs that you want to call from the COBOL non-DLL programs in the program object that contains the main program. Use static calls from the COBOL non-DLL programs to call the COBOL DLL programs.

The COBOL DLL programs in the program object that contains the main program can call COBOL DLL programs in other DLLs.

- Put the COBOL DLL programs in DLLs and call them from COBOL non-DLL programs with CALL *function-pointer*, where *function-pointer* is set to a function descriptor of the target program. You can obtain the address of the function descriptor for the program in the DLL by calling a C routine that uses `dllload` and `dllqueryfn`.

“Example: calling DLLs from non-DLLs” on page 514

Example: calling DLLs from non-DLLs

The following example shows how a COBOL program that is not in a DLL (COBOL1) can call a COBOL program that is in a DLL (program ooc05R in DLL OOC05R).

```

CBL NODYNAM
  IDENTIFICATION DIVISION.
  PROGRAM-ID. 'COBOL1'.
  ENVIRONMENT DIVISION.
  CONFIGURATION SECTION.
  INPUT-OUTPUT SECTION.
  FILE-CONTROL.
  DATA DIVISION.
  FILE SECTION.
  WORKING-STORAGE SECTION.
  01 DLL-INFO.
     03 DLL-LOADMOD-NAME PIC X(12).
     03 DLL-PROGRAM-NAME PIC X(160).
     03 DLL-PROGRAM-HANDLE FUNCTION-POINTER.
  77 DLL-RC PIC S9(9) BINARY.
  77 DLL-STATUS PIC X(1) VALUE 'N'.
     88 DLL-LOADED VALUE 'Y'.
     88 DLL-NOT-LOADED VALUE 'N'.

  PROCEDURE DIVISION.

     IF DLL-NOT-LOADED
     THEN
  *      Move the names in. They must be null terminated.
     MOVE Z'OOC05R' TO DLL-LOADMOD-NAME
     MOVE Z'ooc05r' TO DLL-PROGRAM-NAME

  *      Call the C routine to load the DLL and to get the
  *      function descriptor address.
     CALL 'A1CCDLGT' USING BY REFERENCE DLL-INFO
                        BY REFERENCE DLL-RC

     IF DLL-RC = 0
     THEN
       SET DLL-LOADED TO TRUE
     ELSE
       DISPLAY 'A1CCDLGT failed with rc = '
         DLL-RC
       MOVE 16 TO RETURN-CODE
       STOP RUN
     END-IF
  END-IF

  *      Use the function pointer on the call statement to call the
  *      program in the DLL.
  *      Call the program in the DLL.
     CALL DLL-PROGRAM-HANDLE

  GOBACK.

#include <stdio.h>
#include <dll.h>
#pragma linkage (A1CCDLGT,COBOL)

typedef struct dll_lm {
  char      dll_loadmod_name[(12)];
  char      dll_func_name[(160)];
  void      (*fptr) (void); /* function pointer */

```

```

    } dll_lm;

void A1CCDLGT (dll_lm *dll, int *rc)
{
    dllhandle *handle;
    void (*fptr1)(void);
    *rc = 0;
    /* Load the DLL */
    handle = dllload(dll->dll_loadmod_name);
    if (handle == NULL) {
        perror("A1CCDLGT failed on call to load DLL./n");
        *rc = 1;
        return;
    }

    /* Get the address of the function */
    fptr1 = (void (*)(void))
        dllqueryfn(handle,dll->dll_func_name);
    if (fptr1 == NULL) {
        perror("A1CCDLGT failed on retrieving function./n");
        *rc = 2;
        return;
    }
    /* Return the function pointer */
    dll->fptr = fptr1;
    return;
}

```

Using COBOL DLLs with C/C++ programs

COBOL support for DLLs interoperates with the DLL support in the z/OS C/C++ products, except for COBOL EXTERNAL data. In particular, COBOL applications can call functions that are exported from C/C++ DLLs, and C/C++ applications can call COBOL programs that are exported from COBOL DLLs.

COBOL data items that are declared with the EXTERNAL attribute are independent of DLL support. These data items are accessible by name from any COBOL program in the run unit that declares them, regardless of whether the programs are in DLLs.

The COBOL options DLL, RENT, and EXPORTALL work much the same way as the C/C++ DLL, RENT, and EXPORTALL options. (The DLL option applies only to C.) However, the C/C++ compiler produces DLL-enabled code by default.

You can pass a C/C++ DLL function pointer to COBOL and use it within COBOL, receiving the C/C++ function pointer as a function-pointer data item. The following example shows a COBOL call to a C function that returns a function pointer to a service, followed by a COBOL call to the service.

```

Identification Division.
Program-id. Demo.
Data Division.
Working-Storage section.
01 fp usage function-pointer.
Procedure Division.
    Call "c-function" returning fp.
    Call fp.

```

RELATED TASKS

“Compiling programs to create DLLs” on page 508

“Linking DLLs” on page 509

RELATED REFERENCES

"DLL" on page 321

"EXPORTALL" on page 326

"RENT" on page 352

EXTERNAL clause (*Enterprise COBOL Language Reference*)

CALLINTERFACE (*Enterprise COBOL Language Reference*)

Using DLLs in OO COBOL applications

You must compile each COBOL class definition using the DLL, THREAD, RENT, and DBCS compiler options, and link-edit it into a separate DLL module using the RENT binder option.

RELATED TASKS

Chapter 16, "Compiling, linking, and running OO applications," on page 291

"Compiling programs to create DLLs" on page 508

"Linking DLLs" on page 509

RELATED REFERENCES

"DLL" on page 321

"THREAD" on page 366

"RENT" on page 352

"DBCS" on page 319

Chapter 27. Preparing COBOL programs for multithreading

You can run COBOL programs in multiple threads within a process under batch, TSO, IMS, or z/OS UNIX.

There is no explicit COBOL language to use for multithreaded execution; rather, you compile with the THREAD compiler option.

COBOL does not directly support managing program threads. However, you can run COBOL programs that you compile with the THREAD compiler option in multithreaded application servers, in applications that use a C/C++ driver program to create the threads, in programs that interoperate with Java and use Java threads, and in applications that use PL/I tasking. In other words, other programs can call COBOL programs in such a way that the COBOL programs run in multiple threads within a process or as multiple program invocation instances within a thread. Your threaded application must run within a single Language Environment enclave.

Choosing LOCAL-STORAGE or WORKING-STORAGE: Because you must code your multithreaded programs as recursive, the persistence of data is that of any recursive program:

- Data items in the LOCAL-STORAGE SECTION are automatically allocated for each instance of a program invocation. When a program runs in multiple threads simultaneously, each invocation has a separate copy of LOCAL-STORAGE data.
- Data items in the WORKING-STORAGE SECTION are allocated once for each program and are thus available in their last-used state to all invocations of the program.

For the data that you want to isolate to an individual program invocation instance, define the data in the LOCAL-STORAGE SECTION. In general, this choice is appropriate for working data in threaded programs. If you define data in WORKING-STORAGE and your program changes the contents of the data, you must take one of the following actions:

- Structure your application so that you do not access data in WORKING-STORAGE simultaneously from multiple threads.
- If you do access data simultaneously from separate threads, write appropriate serialization code.

RELATED CONCEPTS

“Multithreading” on page 518

RELATED TASKS

“Choosing THREAD to support multithreading” on page 519

“Transferring control to multithreaded programs” on page 519

“Ending multithreaded programs” on page 520

“Processing files with multithreading” on page 520

“Handling COBOL limitations with multithreading” on page 522

RELATED REFERENCES

“THREAD” on page 366

PROGRAM-ID paragraph (*Enterprise COBOL Language Reference*)

Multithreading

To use COBOL support for multithreading, you need to understand how processes, threads, run units, and program invocation instances relate to each other.

The operating system and multithreaded applications can handle execution flow within a *process*, which is the course of events when all or part of a program runs. Programs that run within a process can share resources. Processes can be manipulated. For example, they can have a high or low priority in terms of the amount of time that the system devotes to running the process.

Within a process, an application can initiate one or more *threads*, each of which is a stream of computer instructions that controls that thread. A multithreaded process begins with one stream of instructions (one thread) and can later create other instruction streams to perform tasks. These multiple threads can run concurrently. Within a thread, control is transferred between executing programs.

In a multithreaded environment, a COBOL *run unit* is the portion of the process that includes threads that have actively executing COBOL programs. The COBOL run unit continues until no COBOL program is active in the execution stack for any of the threads. For example, a called COBOL program contains a GOBACK statement and returns control to a C program. Within the run unit, COBOL programs can call non-COBOL programs, and vice versa.

Within a thread, control is transferred between separate COBOL and non-COBOL programs. For example, a COBOL program can call another COBOL program or a C program. Each separately called program is a *program invocation instance*. Program invocation instances of a particular program can exist in multiple threads within a given process.

The following illustration shows these relationships between processes, threads, run units, and program invocation instances.

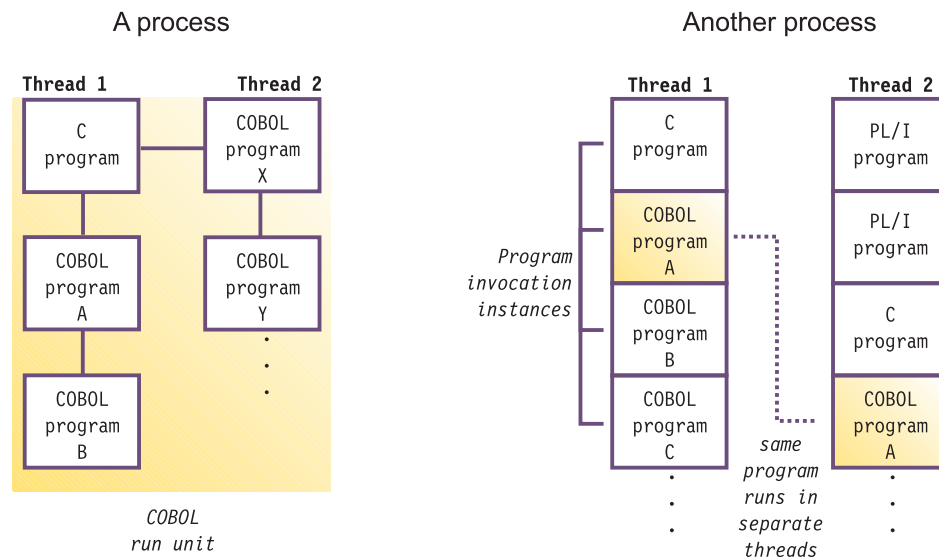

RELATED CONCEPTS

Language Environment Programming Guide (Program management model, Understanding the basics: threads)

RELATED TASKS

- “Choosing THREAD to support multithreading”
- “Transferring control to multithreaded programs”
- “Ending multithreaded programs” on page 520
- “Processing files with multithreading” on page 520
- “Handling COBOL limitations with multithreading” on page 522

RELATED REFERENCES

- “THREAD” on page 366

Choosing THREAD to support multithreading

Use the THREAD compiler option for multithreading support. Use THREAD if your program will be called in more than one thread in a single process by an application. However, THREAD might adversely affect performance because of the serialization logic that is automatically generated.

In order to run COBOL programs in more than one thread, you must compile all of the COBOL programs in the application using the THREAD compiler option. You must also compile them with the RENT compiler option and link them with the RENT option of the binder (linkage-editor).

Use the THREAD option when you compile object-oriented (OO) clients and classes.

Language restrictions: When you use the THREAD option, you cannot use certain language elements. For details, see the related reference below.

Recursion: Before you compile a program using the THREAD compiler option, you must specify the RECURSIVE phrase in the PROGRAM-ID paragraph. If you do not do so, an error will occur.

RELATED TASKS

- “Sharing data in recursive or multithreaded programs” on page 17
- “Compiling OO applications under z/OS UNIX” on page 291

RELATED REFERENCES

- “THREAD” on page 366

Transferring control to multithreaded programs

When you write COBOL programs for a multithreaded environment, choose appropriate program linkage statements.

As in single-threaded environments, a called program is in its initial state when it is first called within a run unit and when it is first called after a CANCEL to the called program. Ensure that the program that you name on a CANCEL statement is not active on any thread. If you try to cancel an active program, a severity-3 Language Environment condition occurs.

If your threaded application requires preinitialization, use the Language Environment services (CEEPIPI interface). You cannot use the COBOL-specific interfaces for preinitialization (runtime option RTEREUS) to establish a reusable environment from any program that has been compiled with the THREAD option.

RELATED CONCEPTS

Language Environment Programming Guide (What happens during termination: enclave termination)

RELATED TASKS

“Ending multithreaded programs”

“Ending and reentering main programs or subprograms” on page 474

Ending multithreaded programs

You can end a multithreaded program by using GOBACK, EXIT PROGRAM, or STOP RUN.

Use GOBACK to return to the caller of the program. When you use GOBACK from the first program in a thread, the thread is terminated. If that thread is the initial thread in an enclave, the entire enclave is terminated.

Use EXIT PROGRAM as you would GOBACK, except from a main program where it has no effect.

Use STOP RUN to terminate the entire Language Environment enclave and to return control to the caller of the main program (which might be the operating system). All threads that are executing within the enclave are terminated.

RELATED CONCEPTS

Language Environment Programming Guide (What happens during termination: enclave termination)

RELATED TASKS

“Ending and reentering main programs or subprograms” on page 474

Processing files with multithreading

In threaded applications, you can code COBOL statements for input and output in QSAM, VSAM, and line-sequential files.

Each file definition (FD) has an implicit serialization lock. This lock is used with automatic serialization logic during the input or output operation that is associated with the execution of the following statements:

- OPEN
- CLOSE
- READ
- WRITE
- REWRITE
- START
- DELETE

Automatic serialization also occurs for the implicit MOVE that is associated with the following statements:

```
WRITE record-name FROM identifier  
READ file-name INTO identifier
```

Automatic serialization is not applied to any statements specified within the following conditional phrases:

- AT END

- NOT AT END
- INVALID KEY
- NOT INVALID KEY
- AT END-OF-PAGE
- NOT AT END-OF-PAGE

RELATED CONCEPTS

“File-definition (FD) storage”

RELATED TASKS

“Closing QSAM files” on page 173

“Closing VSAM files” on page 200

“Coding ERROR declaratives” on page 244

“Serializing file access with multithreading”

File-definition (FD) storage

On all program invocations, the storage that is associated with a file definition (such as FD records and the record area that is associated with the SAME RECORD AREA clause) is allocated and available in its last-used state.

All threads of execution share this storage. You can depend on automatic serialization for this storage during the execution of the OPEN, CLOSE, READ, WRITE, REWRITE, START, and DELETE statements, but not between uses of these statements.

RELATED TASKS

“Serializing file access with multithreading”

Serializing file access with multithreading

To take full advantage of automatic serialization and to avoid explicitly writing your own serialization logic, use one of the recommended file organizations and usage patterns when you access files in threaded programs.

Use one of the following file organizations:

- Sequential organization
- Line-sequential organization
- Relative organization with sequential access
- Indexed organization with sequential access

Use the following pattern for input:

```
OPEN INPUT fn
. . .
READ fn INTO local-storage-item
. . .
* Process the record from the local-storage item
. . .
CLOSE fn
```

Use the following pattern for output:

```
OPEN OUTPUT fn
. . .
* Construct output record in local-storage item
. . .
WRITE rec FROM local-storage-item
. . .
CLOSE fn
```

With other usage patterns, you must take one of the following actions:

- Verify the safety of your application logic. Ensure that two instances of the program are never simultaneously active on different threads.
- Code explicit serialization logic by using calls to POSIX services.

To avoid serialization problems when you access a file from multiple threads, define the data items that are associated with the file (such as file-status data items and key arguments) in the LOCAL-STORAGE SECTION.

“Example: usage patterns of file input and output with multithreading”

RELATED TASKS

“Calling UNIX/POSIX APIs” on page 466

Example: usage patterns of file input and output with multithreading

The following examples show the need for explicit serialization logic when you deviate from the recommended usage pattern for file input and output in your multithreaded applications. These examples also explain the unexpected behavior that might result if you fail to handle serialization properly.

In each example, two instances of a program that contains the sample operations are running within one run unit on two different threads.

```
READ F1
. . .
REWRITE R1
```

In the example above, the second thread might execute the READ statement after the READ statement is executed on the first thread but before the REWRITE statement is executed on the first thread. The REWRITE statement might not update the record that you intended. To ensure the results that you want, write explicit serialization logic.

```
READ F1
. . .
* Process the data in the FD record description entry for F1
. . .
```

In the example above, the second thread might execute the READ statement while the first thread is still processing a record in the FD record description entry. The second READ statement would overlay the record that the first thread is processing. To avoid this problem, use the recommended technique:

```
READ F1 INTO LOCAL-STORAGE-item
```

Other cases: You must give similar consideration to other usage patterns that involve a sequence of related input and output operations, such as START followed by READ NEXT, or READ followed by DELETE. Take appropriate steps to ensure the correct processing of file input and output.

Handling COBOL limitations with multithreading

Some COBOL applications depend on subsystems or other applications. In a multithreaded environment, these dependencies and others result in some limitations on COBOL programs.

In general, you must synchronize access to resources that are visible to the application within a run unit. Exceptions to this requirement are `DISPLAY` and `ACCEPT`, which you can use from multiple threads, and supported COBOL file I/O statements that have the recommended usage pattern; all synchronization is provided for these by the runtime environment.

CICS: You cannot run multithreaded applications in CICS. In CICS, you can run a COBOL program that has been compiled with the `THREAD` option and that is part of an application that has no multiple threads or PL/I tasks.

Recursive: Because you must code the programs in a multithreaded application as recursive, you must adhere to all the restrictions and programming considerations that apply to recursive programs, such as not coding nested programs.

Reentrancy: You must compile your multithreading programs with the `RENT` compiler option and link them with the `RENT` option of the binder (linkage-editor).

POSIX and PL/I: If you use POSIX threads in your multithreaded application, you must specify the Language Environment runtime option `POSIX(ON)`. If the application uses PL/I tasking, you must specify `POSIX(OFF)`. You cannot mix POSIX threads and PL/I tasks in the same application.

PL/I tasking: To include COBOL programs in applications that contain multiple PL/I tasks, follow these guidelines:

- Compile all COBOL programs that you run in multiple PL/I tasks with the `THREAD` option. If you compile any COBOL program with the `NOTHREAD` option, all of the COBOL programs must run in one PL/I task.
- You can call COBOL programs compiled with the `THREAD` option from one or more PL/I tasks. However, calls from PL/I programs to COBOL programs cannot include the `TASK` or `EVENT` option. The PL/I tasking call must first call a PL/I program or function that in turn calls the COBOL program. This indirection is required because you cannot specify the COBOL program directly as the target of a PL/I `CALL` statement that includes the `TASK` or `EVENT` option.
- Be aware that issuing a `STOP RUN` statement from a COBOL program or a `STOP` statement from a PL/I program terminates the entire Language Environment enclave, including all the tasks of execution.
- Do not code explicit POSIX threading (calls to `pthread_create()`) in any run unit that includes PL/I tasking.

C and Language Environment conforming assembler: You can combine your multithreaded COBOL programs with C programs and Language Environment conforming assembler programs in the same run unit when those programs are also appropriately coded for multithreaded execution.

AMODE: You must run your multithreaded applications with `AMODE 31`. You can run a COBOL program that has been compiled with the `THREAD` option with `AMODE 24` as part of an application that does not have multiple threads or PL/I tasks.

Asynchronous signals: In a threaded application your COBOL program might be interrupted by an asynchronous signal or interrupt. If your program contains logic that cannot tolerate such an interrupt, you must disable the interrupts for the duration of that logic. Call a C/C++ function to set the signal mask appropriately.

Older COBOL programs: To run your COBOL programs on multiple threads of a multithreaded application, you must compile them with Enterprise COBOL and use the THREAD option. Run applications that contain programs compiled by older compilers only on one thread.

IGZETUN and IGZEOPT: Do not use the modules IGZETUN (for storage tuning) or IGZEOPT (for runtime options) for applications in which the main program has been compiled with the THREAD option; these CSECTs are ignored.

UPSI switches: All programs and all threads in an application share a single copy of UPSI switches. If you modify switches in a threaded application, you must code appropriate serialization logic.

RELATED TASKS

“Making recursive calls” on page 487

“Serializing file access with multithreading” on page 521

XL C/C++ Programming Guide (Using threads in z/OS UNIX System Services applications)

Language Environment Writing ILC Communication Applications

Part 5. Using XML and COBOL together

Chapter 28. Processing XML input

You can process XML input in a COBOL program by using the XML PARSE statement.

The XML PARSE statement is the COBOL language interface to either of two high-speed XML parsers. You use the XMLPARSE compiler option to select the appropriate parser for your application:

- XMLPARSE(XMLSS) selects the z/OS XML System Services parser.
This option provides enhanced features such as namespace processing, validation of XML documents with respect to an XML schema, and conversion of text fragments to national character representation (Unicode UTF-16).
- XMLPARSE(COMPAT) selects the XML parser that is built into the COBOL library.
This option provides compatibility with XML parsing in Enterprise COBOL Version 3 and Version 4.

Processing XML input involves passing control between the XML parser and a processing procedure in which you handle parser events.

Use the following COBOL facilities to process XML input:

- The XML PARSE statement to begin XML parsing and to identify the source XML document and the processing procedure.
You can also use the following optional phrases of the XML PARSE statement:
 - ENCODING to specify the encoding of the XML document
 - VALIDATING to identify an XML schema against which the XML document is to be validated
- The processing procedure to control the parsing, that is, receive and process XML events and associated document fragments, and return to the parser for continued processing
- Special registers to exchange information between the parser and the processing procedure:
 - XML-CODE to receive the status of XML parsing and, in some cases, to return information to the parser
 - XML-EVENT to receive the name of each XML event from the parser
 - XML-INFORMATION provides a mechanism to easily determine whether an XML event is complete
 - XML-NTEXT to receive XML document fragments that are returned as national character data
 - XML-TEXT to receive document fragments that are returned as alphanumeric data
 - XML-NAMESPACE or XML-NNAMESPACE to receive a namespace identifier for a NAMESPACE-DECLARATION XML event, or for an element name or attribute name that is in a namespace
 - XML-NAMESPACE-PREFIX or XML-NNAMESPACE-PREFIX to receive a namespace prefix for a NAMESPACE-DECLARATION XML event, or for an element name or attribute name that is prefixed
- The optional RETURNING NATIONAL phrase of the XML PARSE statement to indicate that the fragments of an XML document in an alphanumeric data item are to be

converted to UTF-16 and returned to the processing procedure in the national special registers XML-NTEXT, XML-NNAMESPACE, and XML-NNAMESPACE-PREFIX

You can use the ENCODING, VALIDATING, and RETURNING NATIONAL phrases of the XML PARSE statement only if XMLPARSE(XMLSS) is in effect.

Link-edit consideration: COBOL programs that contain the XML PARSE statement must be link-edited with AMODE 31.

RELATED CONCEPTS

“XML parser in COBOL”

RELATED TASKS

“Accessing XML documents” on page 530

“Parsing XML documents” on page 530

“Handling XML PARSE exceptions” on page 552

“Terminating XML parsing” on page 556

RELATED REFERENCES

“XMLPARSE” on page 373 (compiler option)

“The encoding of XML documents” on page 546

Appendix C, “XML reference material,” on page 701

Extensible Markup Language (XML)

XML parser in COBOL

Enterprise COBOL provides an event-based interface that lets you parse XML documents and transform them to COBOL data structures.

The XML parser finds fragments within the source XML document, and your processing procedure acts on those fragments. The fragments are associated with XML events; you code the processing procedure to handle each XML event.

Execution of the XML PARSE statement begins the parsing and establishes the processing procedure with the parser. The parser transfers control to the processing procedure for each XML event that it detects while processing the document. After processing the event, the processing procedure automatically returns control to the parser. Each normal return from the processing procedure causes the parser to continue analyzing the XML document to report the next event. Throughout this operation, control passes back and forth between the parser and the processing procedure.

In the XML PARSE statement, you can also specify two imperative statements to which you want control to be passed at the end of the parsing: one if a normal end occurs, and the other if an exception condition exists.

The following figure shows a high-level overview of the basic exchange of control between the parser and your COBOL program:

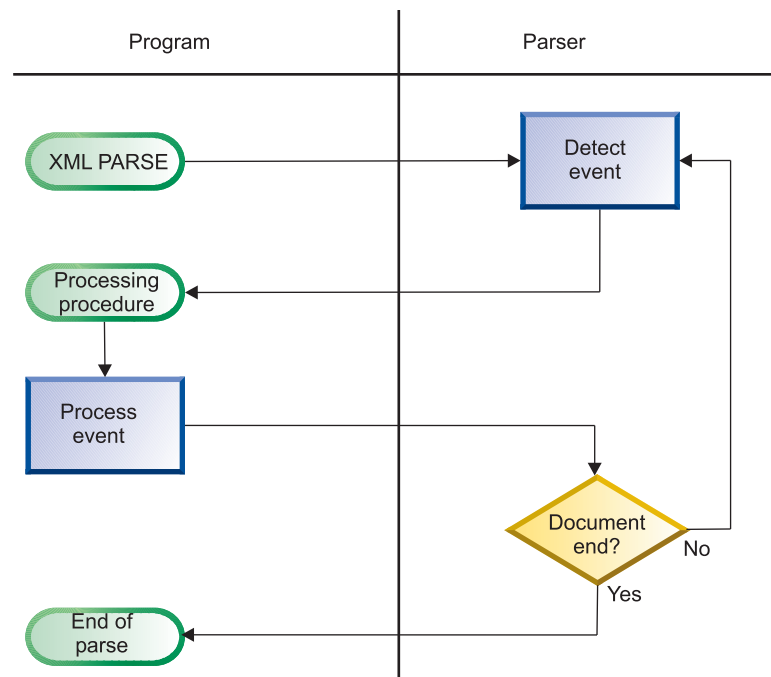

Normally, parsing continues until the entire XML document has been parsed.

The XML parser checks XML documents for most aspects of well formedness. A document is *well formed* if it adheres to the XML syntax in the *XML specification* and follows some additional rules such as proper use of end tags and uniqueness of attribute names.

When you parse an XML document with validation against an XML schema, the z/OS XML System Services parser additionally verifies that the XML document adheres to the content and structure prescribed in the schema. For example, the parser checks that there are no unexpected elements or attributes, that no required elements or attributes are missing, and that any values of elements or attributes are legal.

RELATED CONCEPTS

“XML schemas” on page 542

“XML input document encoding” on page 547

RELATED TASKS

“Parsing XML documents” on page 530

“Parsing XML documents with validation” on page 540

“Handling XML PARSE exceptions” on page 552

“Terminating XML parsing” on page 556

RELATED REFERENCES

“The encoding of XML documents” on page 546

XML specification

Accessing XML documents

Before you can parse an XML document using an XML PARSE statement, you must make the document available to your program. Common methods of acquiring an XML document are by retrieval from a WebSphere MQ message, a CICS transient queue or communication area, or an IMS message processing queue; or by reading the document from a file.

If the XML document that you want to parse is held in a file, use ordinary COBOL facilities to place the document into a data item in your program:

- A FILE-CONTROL entry to define the file to your program.
- An OPEN statement to open the file.
- READ statements to read all the records from the file into a data item (either an elementary item of category alphanumeric or national, or an alphanumeric or national group). You can define the data item in the WORKING-STORAGE SECTION or the LOCAL-STORAGE SECTION.
- Optionally, the STRING statement to string all of the separate records together into one continuous stream, to remove extraneous blanks, and to handle variable-length records.

| If the XMLPARSE(XMLSS) option is in effect, you can parse an XML document that is
| in a file by passing the parser one record (or *segment*) of text from the file at a
| time. This capability is useful for parsing very large XML documents.

RELATED TASKS

"Coding COBOL programs to run under CICS" on page 429
Chapter 22, "Developing COBOL programs for IMS," on page 453
"Parsing XML documents one segment at a time" on page 543

RELATED REFERENCES

"XMLPARSE" on page 373 (compiler option)

Parsing XML documents

To parse XML documents, use the XML PARSE statement, specifying the XML document that is to be parsed and the processing procedure for handling XML events that occur during parsing, as shown in the following code fragment.

```
XML PARSE xml-document
  PROCESSING PROCEDURE xml-event-handler
  ON EXCEPTION
    DISPLAY 'XML document error ' XML-CODE
    STOP RUN
  NOT ON EXCEPTION
    DISPLAY 'XML document was successfully parsed.'
END-XML
```

In the XML PARSE statement, you first identify the *parse data item* (xml-document in the example above) that contains the XML document character stream. In the DATA DIVISION, define the parse data item as an elementary data item of category national or as a national group item if the encoding of the document is Unicode UTF-16; otherwise, define the parse data item as an elementary alphanumeric data item or an alphanumeric group item:

- If the parse data item is national, the XML document must be encoded in UTF-16, CCSID 1200.

- If the parse data item is alphanumeric, its content must be encoded in one of the supported code pages described in the related reference about the encoding of XML documents.

Next, specify the name of the processing procedure (`xml-event-handler` in the example above) that is to handle the XML events that occur during parsing of the document.

If the `XMLPARSE(XMLSS)` compiler option is in effect, you can also use any of these optional phrases of the `XML PARSE` statement:

- `ENCODING`, to specify the CCSID of the document
- `RETURNING NATIONAL`, to cause the parser to automatically convert UTF-8 or single-byte characters to national characters for return to the processing procedure
- `VALIDATING`, to cause the parser to validate the document against an XML schema

In addition, you can specify either or both of the following optional phrases (as shown in the fragment above) to indicate the action to be taken after parsing finishes:

- `ON EXCEPTION`, to receive control if an unhandled exception occurs during parsing
- `NOT ON EXCEPTION`, to receive control otherwise

You can end the `XML PARSE` statement with the explicit scope terminator `END-XML`. Use `END-XML` to nest an `XML PARSE` statement that uses the `ON EXCEPTION` or `NOT ON EXCEPTION` phrase in a conditional statement.

The parser passes control to the processing procedure for each XML event. Control returns to the parser at the end of the processing procedure. This exchange of control between the XML parser and the processing procedure continues until one of the following events occurs:

- The entire XML document was parsed, as indicated by the `END-OF-DOCUMENT` event.
- If `XMLPARSE(XMLSS)` is in effect, either:
 - The parser detects an error in the document and signals an `EXCEPTION` event (regardless of the kind of exception).
 - The parser signals an `END-OF-INPUT` event, and the processing procedure returns to the parser with special register `XML-CODE` still set to zero, which indicates that no further XML data will be provided to the parser.
- If `XMLPARSE(COMPAT)` is in effect, either:
 - The parser signals an encoding conflict `EXCEPTION` event, and the processing procedure does not reset special register `XML-CODE` to zero or to the correct CCSID before returning to the parser.
 - The parser detects an error in the document and signals an `EXCEPTION` event (other than an encoding conflict), and the processing procedure does not reset special register `XML-CODE` to zero before returning to the parser.
- The parsing process is terminated deliberately by the user's code in the processing procedure that sets the `XML-CODE` special register to `-1` before it returns to the parser.

RELATED CONCEPTS

"XML events" on page 534

“XML-CODE” on page 535
 “XML schemas” on page 542
 “XML-INFORMATION” on page 536

RELATED TASKS

“Writing procedures to process XML”
 “Parsing XML documents with validation” on page 540
 “Parsing XML documents one segment at a time” on page 543
 “Parsing XML documents encoded in UTF-8” on page 551

RELATED REFERENCES

“XMLPARSE” on page 373 (compiler option)
 “The encoding of XML documents” on page 546
 “XML PARSE exceptions with XMLPARSE(XMLSS) in effect” on page 701
 “XML PARSE exceptions with XMLPARSE(COMPAT) in effect” on page 703
 XML PARSE statement (*Enterprise COBOL Language Reference*)

Writing procedures to process XML

In your processing procedure, code statements to handle XML events.

For each event that the parser encounters, the parser passes information to the processing procedure in several special registers. Use the content of those special registers to populate COBOL data structures and to control the processing.

Examine the XML-EVENT special register to determine which event the parser passed to the processing procedure. XML-EVENT contains an event name, such as 'START-OF-ELEMENT'. Obtain the text associated with the event from the XML-TEXT or XML-NTEXT special register.

If the XMLPARSE(XMLSS) option is in effect, you can use special register XML-NAMESPACE or XML-NNAMESPACE to determine the namespace identifier, if any, that is associated with the XML event, and examine the XML-NAMESPACE-PREFIX or XML-NNAMESPACE-PREFIX special register to determine the associated prefix, if any.

When used in nested programs, the XML special registers are implicitly defined as GLOBAL in the outermost program.

For additional details about the XML special registers, see the following table.

Table 64. Special registers used by the XML parser

Special register	Implicit definition and usage	Content
XML-EVENT ¹	PICTURE X(30) USAGE DISPLAY VALUE SPACE	The name of the XML event
XML-CODE ²	PICTURE S9(9) USAGE BINARY VALUE ZERO	An exception code or zero for each XML event
XML-INFORMATION ¹	PICTURE S9(9) USAGE BINARY VALUE 0	A mechanism to easily determine whether an XML EVENT is complete
XML-TEXT ¹	Variable-length elementary category alphanumeric item	Text (corresponding to the event that the parser encountered) from the XML document if you specify an alphanumeric item for the XML PARSE identifier ³
XML-NTEXT ¹	Variable-length elementary category national item	Text (corresponding to the event that the parser encountered) from the XML document if you specify a national item for the XML PARSE identifier ³
XML-NAMESPACE ^{1, 4}	Variable-length elementary category alphanumeric item	The namespace identifier for a NAMESPACE-DECLARATION XML event or for an element or attribute name that is in a namespace, if the XML document is in an alphanumeric data item ³

Table 64. Special registers used by the XML parser (continued)

Special register	Implicit definition and usage	Content
XML-NNAMESPACE ^{1, 4}	Variable-length elementary category national item	The namespace identifier for a NAMESPACE-DECLARATION XML event or for an element or attribute name that is in a namespace, if the XML document is in a national data item or the RETURNING NATIONAL phrase is specified in the XML PARSE statement
XML-NAMESPACE-PREFIX ^{1, 4}	Variable-length elementary category national item	The prefix, if any, for a NAMESPACE-DECLARATION XML event or for an element or attribute name that is in a nondefault namespace, if the XML document is in an alphanumeric data item ³
XML-NNAMESPACE-PREFIX ^{1, 4}	Variable-length elementary category national item	The prefix, if any, for a NAMESPACE-DECLARATION XML event or for an element or attribute name that is in a nondefault namespace, if the XML document is in a national data item or the RETURNING NATIONAL phrase is specified in the XML PARSE statement

1. You cannot use this special register as a receiving data item.
2. The XML GENERATE statement also uses XML-CODE. Therefore, if you have an XML GENERATE statement in the processing procedure, save the value of XML-CODE before the XML GENERATE statement, and restore the saved value after the XML GENERATE statement.
3. If you specify the RETURNING NATIONAL phrase in the XML PARSE statement for an alphanumeric data item, text is returned in the corresponding national special register. You can specify the RETURNING NATIONAL phrase only if the XMLPARSE(XMLSS) option is in effect.
4. The parser sets the namespace special registers only if the XMLPARSE(XMLSS) option is in effect.

Restrictions:

- A processing procedure must not directly execute an XML PARSE statement. However, if a processing procedure passes control to a method or outermost program by using an INVOKE or CALL statement, the target method or program can execute the same or a different XML PARSE statement. You can also execute the same XML statement or different XML statements simultaneously from a program that is running on multiple threads.
- The range of the processing procedure must not cause the execution of any GOBACK or EXIT PROGRAM statement, except to return control from a method or program to which control was passed by an INVOKE or CALL statement, respectively, that is executed in the range of the processing procedure.
You can code a STOP RUN statement in a processing procedure to end the run unit.

The compiler inserts a return mechanism after the last statement in each processing procedure.

“Example: program for processing XML” on page 558

RELATED CONCEPTS

- “XML events” on page 534
- “XML-CODE” on page 535
- “XML-TEXT and XML-NTEXT” on page 537
- “XML-NAMESPACE and XML-NNAMESPACE” on page 537
- “XML-NAMESPACE-PREFIX and XML-NNAMESPACE-PREFIX” on page 538

RELATED TASKS

- “Parsing XML documents one segment at a time” on page 543
- “Parsing XML documents with validation” on page 540
- “Terminating XML parsing” on page 556

RELATED REFERENCES

"XMLPARSE" on page 373 (compiler option)
XML-EVENT (*Enterprise COBOL Language Reference*)

XML events

An *XML event* results when the XML parser detects various conditions (such as END-OF-INPUT or EXCEPTION) or encounters document fragments (such as CONTENT-CHARACTERS or START-OF-CDATA-SECTION) while processing an XML document.

For each event that occurs during XML parsing, the parser sets the associated event name in the XML-EVENT special register, and passes the XML-EVENT special register to the processing procedure. Depending on the event, the parser sets other special registers to contain additional information about the event.

In most cases, the parser sets the XML-TEXT or XML-NTEXT special register to the XML fragment that caused the event:

- If the XMLPARSE(COMPAT) compiler option is in effect, the parser sets XML-NTEXT if the XML document is in a national data item, or if the parser finds a character reference; otherwise, the parser sets XML-TEXT.
- If XMLPARSE(XMLSS) is in effect, the parser sets XML-NTEXT if the RETURNING NATIONAL phrase is specified in the XML PARSE statement, or if the XML document is in a national data item; otherwise, the parser sets XML-TEXT.

If XMLPARSE(XMLSS) is in effect, the parser sets the namespace special registers for a NAMESPACE-DECLARATION event, or if it encounters a name that is in a namespace.

When the parser detects an encoding conflict or a well-formedness or validation error in the document, it sets XML-EVENT to 'EXCEPTION' and provides additional information about the exception in the XML-CODE special register. You can parse with validation only if XMLPARSE(XMLSS) is in effect. For further details, see the related task about parsing with validation.

For a detailed description of the set of XML events, see the related reference about XML-EVENT.

"Example: parsing a simple document" on page 557

RELATED CONCEPTS

"XML parser in COBOL" on page 528
"XML-CODE" on page 535
"XML-INFORMATION" on page 536
"XML-TEXT and XML-NTEXT" on page 537
"XML-NAMESPACE and XML-NNAMESPACE" on page 537
"XML-NAMESPACE-PREFIX and XML-NNAMESPACE-PREFIX" on page 538

RELATED TASKS

"Writing procedures to process XML" on page 532
"Parsing XML documents with validation" on page 540

RELATED REFERENCES

"XMLPARSE" on page 373 (compiler option)
"XML PARSE exceptions with XMLPARSE(XMLSS) in effect" on page 701
"XML PARSE exceptions with XMLPARSE(COMPAT) in effect" on page 703
XML-EVENT (*Enterprise COBOL Language Reference*)

XML-CODE

For each XML event except an EXCEPTION event, the parser sets the value of the XML-CODE special register to zero. For an EXCEPTION event, the parser sets XML-CODE to a value that identifies the specific exception.

For information about the possible exception codes, see the related references.

When the parser returns control to the XML PARSE statement from your processing procedure, XML-CODE generally contains the most recent value that was set by the parser. However, for any event other than EXCEPTION, if you set XML-CODE to -1 in your processing procedure, parsing terminates with a user-initiated exception condition when control returns to the parser, and XML-CODE retains the value -1.

For an EXCEPTION XML event when XMLPARSE(COMPAT) is in effect, your processing procedure can, in some cases, set XML-CODE to a meaningful value before control returns to the parser. (For details, see the related tasks about handling XML PARSE exceptions and handling encoding conflicts.) If you set XML-CODE to any other nonzero value or set it for any other exception, the parser resets XML-CODE to the original exception code.

For a START-OF-DOCUMENT XML event when compiler option XMLPARSE(COMPAT) is in effect, your processing procedure can set XML-CODE to 1 before control returns to the parser. This action instructs the parser to release (at the end of parsing) any Language Environment resources acquired during parsing.

The following table shows the results of setting XML-CODE to various values. The leftmost column shows the type of XML event passed to the processing procedure; the other column headings show the XML-CODE value set by the processing procedure. The cell at the intersection of each row and column shows the action that the parser takes upon return from the processing procedure for a given combination of XML event and XML-CODE value.

Table 65. Results of processing-procedure changes to XML-CODE with XMLPARSE(XMLSS) in effect

XML event type	XML-CODE set to -1	XML-CODE set to 0	XML-CODE set to 1	XML-CODE set to other nonzero values
Fatal EXCEPTION	Ignores setting; keeps original XML-CODE value	Ignores setting; keeps original XML-CODE value	Ignores setting; keeps original XML-CODE value	Ignores setting; keeps original XML-CODE value
Warning EXCEPTION (Reason code 800 or 801)	Ignores setting; keeps original XML-CODE value	Next event is ATTRIBUTE-NAME or START-OF-ELEMENT	Ignores setting; keeps original XML-CODE value	Ignores setting; keeps original XML-CODE value
END-OF-INPUT	Ends immediately; XML-CODE = -1 ¹	Next event is END-OF-DOCUMENT ²	Next event depends on input ²	Fatal runtime error (message 230S)
Normal event	Ends immediately; XML-CODE = -1 ¹	XML-CODE already 0, no change	Fatal runtime error (message 230S)	Fatal runtime error (message 230S)

1. See the related task about terminating XML parsing.

2. See the related task about parsing documents one segment at a time.

Table 66. Results of processing-procedure changes to XML-CODE with XMLPARSE (COMPAT) in effect

XML event type	-1	0	XML-CODE-100,000	Other nonzero value
Encoding-conflict exception (exception codes 50 - 99)	Ignores setting; keeps original XML-CODE value	Chooses encoding depending on the specific exception code ¹	Ignores setting; keeps original XML-CODE value	Ignores setting; keeps original XML-CODE value
Encoding-choice exception (exception codes > 100,000)	Ignores setting; keeps original XML-CODE value	Parses using the CODEPAGE value ²	Parses using the difference (shown above) as the encoding value ²	Ignores setting; keeps original XML-CODE value
Other exception	Ignores setting; keeps original XML-CODE value	Limited continuation only for exception codes 1 - 49 ³	Ignores setting; keeps original XML-CODE value	Ignores setting; keeps original XML-CODE value
Normal event (except START-OF-DOCUMENT)	Ends immediately; XML-CODE = -1 ⁴	[No apparent change to XML-CODE]	Ends immediately; XML-CODE = -1	Ends immediately; XML-CODE = -1
START-OF-DOCUMENT	Ends immediately; XML-CODE = -1 ⁴	[No apparent change to XML-CODE]	Ends immediately; XML-CODE = -1	<ul style="list-style-type: none"> • XML-CODE = 1 • Else ends immediately; XML-CODE = -1

1. See the exception codes in the related reference about XML PARSE exceptions with XMLPARSE (COMPAT) in effect.
2. See the related task about handling encoding conflicts.
3. See the related task about handling XML PARSE exceptions.
4. See the related task about terminating XML parsing.

XML generation also uses the XML-CODE special register. For details, see the related task about handling XML GENERATE exceptions.

RELATED CONCEPTS

“How the XML parser handles errors” on page 554

RELATED TASKS

“Writing procedures to process XML” on page 532

“Parsing XML documents one segment at a time” on page 543

“Handling XML PARSE exceptions” on page 552

“Terminating XML parsing” on page 556

“Handling XML GENERATE exceptions” on page 577

RELATED REFERENCES

“XML PARSE exceptions with XMLPARSE (XMLSS) in effect” on page 701

“XML PARSE exceptions with XMLPARSE (COMPAT) in effect” on page 703

“XML GENERATE exceptions” on page 710

XML-CODE (*Enterprise COBOL Language Reference*)

XML-EVENT (*Enterprise COBOL Language Reference*)

XML-INFORMATION

For most XML events, the parser sets XML-INFORMATION to indicate whether an XML EVENT is complete or whether the XML content spans multiple events.

The application program logic can use the XML-INFORMATION special register to concatenate pieces of parsed XML content together.

RELATED CONCEPTS

“XML events” on page 534

“XML-CODE” on page 535

RELATED TASKS

“Writing procedures to process XML” on page 532

RELATED REFERENCES

XML-TEXT (*Enterprise COBOL Language Reference*)

XML-NTEXT (*Enterprise COBOL Language Reference*)

XML-TEXT and XML-NTEXT

For most XML events, the parser sets XML-TEXT or XML-NTEXT to an associated document fragment.

Typically, the parser sets XML-TEXT if the XML document is in an alphanumeric data item. The parser sets XML-NTEXT if:

- The XML document is in a national data item.
- The XMLPARSE(XMLSS) option is in effect and the RETURNING NATIONAL phrase is specified in the XML PARSE statement.
- The ATTRIBUTE-NATIONAL-CHARACTER or CONTENT-NATIONAL-CHARACTER event occurs.

The special registers XML-TEXT and XML-NTEXT are mutually exclusive. When the parser sets XML-TEXT, XML-NTEXT is empty with length zero. When the parser sets XML-NTEXT, XML-TEXT is empty with length zero.

To determine the number of character encoding units in XML-NTEXT, use the LENGTH intrinsic function; for example FUNCTION LENGTH(XML-NTEXT). To determine the number of bytes in XML-NTEXT, use special register LENGTH OF XML-NTEXT. The number of character encoding units differs from the number of bytes.

To determine the number of bytes in XML-TEXT, use either special register LENGTH OF XML-TEXT or the LENGTH intrinsic function; each returns the number of bytes.

The XML-TEXT and XML-NTEXT special registers are undefined outside the processing procedure.

RELATED CONCEPTS

“XML events” on page 534

“XML-CODE” on page 535

RELATED TASKS

“Writing procedures to process XML” on page 532

RELATED REFERENCES

“XMLPARSE” on page 373 (compiler option)

XML-TEXT (*Enterprise COBOL Language Reference*)

XML-NTEXT (*Enterprise COBOL Language Reference*)

XML-NAMESPACE and XML-NNAMESPACE

If the XMLPARSE(XMLSS) option is in effect, the XML parser sets the XML-NAMESPACE or XML-NNAMESPACE special register to the namespace identifier for a NAMESPACE-DECLARATION XML event, or if it encounters an element name or attribute name that is in a namespace.

The parser sets XML-NNAMESPACE if the XML document is in a national data item, or if the RETURNING NATIONAL phrase is specified in the XML PARSE statement. Otherwise, the parser sets XML-namespace.

The special registers XML-namespace and XML-NNAMESPACE are mutually exclusive: If the parser sets XML-namespace, XML-NNAMESPACE is empty with length zero. If the parser sets XML-NNAMESPACE, XML-namespace is empty with length zero.

To determine the number of character encoding units in XML-NNAMESPACE, use the LENGTH intrinsic function; for example: FUNCTION LENGTH(XML-NNAMESPACE). To determine the number of bytes in XML-NNAMESPACE, use special register LENGTH OF XML-NNAMESPACE. The number of character encoding units differs from the number of bytes.

To determine the number of bytes in XML-namespace, use either special register LENGTH OF XML-namespace or the LENGTH intrinsic function; each returns the number of bytes.

The XML namespace special registers are undefined outside the processing procedure.

RELATED CONCEPTS

"XML events" on page 534

"XML-CODE" on page 535

"XML-namespace-PREFIX and XML-NNAMESPACE-PREFIX"

"XML-TEXT and XML-NTEXT" on page 537

RELATED TASKS

"Writing procedures to process XML" on page 532

RELATED REFERENCES

"XMLPARSE" on page 373 (compiler option)

XML-namespace-PREFIX and XML-NNAMESPACE-PREFIX

If the XMLPARSE(XMLSS) option is in effect, the XML parser sets the XML-namespace-PREFIX special register or the XML-NNAMESPACE-PREFIX special register for a namespace-DECLARATION XML event that also defines a namespace prefix, or if an element name or attribute name in a namespace is prefixed.

The parser sets XML-NNAMESPACE-PREFIX if the XML document is in a national data item, or the RETURNING NATIONAL phrase is specified in the XML PARSE statement. Otherwise, the parser sets XML-namespace-PREFIX.

The special registers XML-namespace-PREFIX and XML-NNAMESPACE-PREFIX are mutually exclusive: If the parser sets XML-namespace-PREFIX, XML-NNAMESPACE-PREFIX is empty with length zero. If the parser sets XML-NNAMESPACE-PREFIX, XML-namespace-PREFIX is empty with length zero.

To determine the number of character encoding units in XML-NNAMESPACE-PREFIX, use the LENGTH intrinsic function; for example: FUNCTION LENGTH(XML-NNAMESPACE-PREFIX). To determine the number of bytes in XML-NNAMESPACE-PREFIX, use special register LENGTH OF XML-NNAMESPACE-PREFIX. The number of character encoding units differs from the number of bytes.

To determine the number of bytes in XML-NAMESPACE-PREFIX, use either special register LENGTH OF XML-NAMESPACE-PREFIX or the LENGTH intrinsic function; each returns the number of bytes.

The XML namespace-prefix special registers are undefined outside the processing procedure.

RELATED CONCEPTS

“XML events” on page 534

“XML-NAMESPACE and XML-NNAMESPACE” on page 537

RELATED TASKS

“Writing procedures to process XML” on page 532

RELATED REFERENCES

“XMLPARSE” on page 373 (compiler option)

Transforming XML text to COBOL data items

Because XML data is neither fixed length nor fixed format, you need to use special techniques when you move XML data to a COBOL data item.

For alphanumeric items, decide whether the XML data should go at the left (default) end, or at the right end, of the COBOL data item. If the data should go at the right end, specify the JUSTIFIED RIGHT clause in the definition of the item.

Give special consideration to numeric XML values, particularly “decorated” monetary values such as '\$1,234.00' or '\$1234'. These two strings might mean the same thing in XML, but need quite different definitions if used as COBOL sending fields.

Use one of the following techniques when you move XML data to COBOL data items:

- If the format is reasonably regular, code a MOVE to an alphanumeric item that you redefine appropriately as a numeric-edited item. Then do the final move to a numeric (operational) item by moving from, and thus de-editing, the numeric-edited item. (A regular format would have the same number of digits after the decimal point, a comma separator for values greater than 999, and so on.)
- For simplicity and vastly increased flexibility, use the following intrinsic functions for alphanumeric XML data:
 - NUMVAL to extract and decode simple numeric values from XML data that represents plain numbers
 - NUMVAL-C to extract and decode numeric values from XML data that represents monetary quantities

However, using these functions is at the expense of performance.

RELATED TASKS

“Converting to numbers (NUMVAL, NUMVAL-C)” on page 117

“Using national data (Unicode) in COBOL” on page 130

“Writing procedures to process XML” on page 532

Parsing XML documents with validation

Validating an XML document determines whether the structure and content of the document conform to a set of rules. In Enterprise COBOL, the rules are expressed in an *XML schema*, which is essentially a blueprint for a class of documents.

To validate XML documents while parsing, use the `VALIDATING` phrase of the `XML PARSE` statement. To do so, you must compile your program using the `XMLPARSE(XMLSS)` compiler option.

You can validate XML documents only against an XML schema.

In Enterprise COBOL, a schema used for XML validation must be in a preprocessed format known as *Optimized Schema Representation*, or *OSR*. To generate a schema in OSR format from a text-form schema, use the `z/OS UNIX` command `xsdosrg`, which invokes the OSR generator provided by `z/OS System Services`. (Alternatively, you can call the OSR generator programmatically. For details, see the related reference about `z/OS XML System Services`.)

For example, to convert the text-form schema in file `item.xsd` to a schema in preprocessed format in file `item.osr`, you can use the following `z/OS UNIX` command:

```
xsdosrg -v -o /u/HLQ/xml/item.osr /u/HLQ/xml/item.xsd
```

Use one of two forms of the `VALIDATING` phrase, depending on the location of the preprocessed schema:

- In one form, you use the `FILE` keyword and specify an XML schema name. In this case, the schema must be in an MVS data set or a `z/OS UNIX` file.
- In the other form, you specify the identifier of a data item that contains the schema.

If you use the `FILE` keyword and specify an XML schema name, the COBOL runtime library automatically retrieves the schema during execution of the `XML PARSE` statement. The following code fragment shows this method of specifying validation:

```
XML PARSE document-item
    VALIDATING WITH FILE schema-name
    PROCESSING PROCEDURE xml-event-handler
ON EXCEPTION
    DISPLAY 'Document has an error.'
    GOBACK
NOT ON EXCEPTION
    DISPLAY 'Document is valid.'
END-XML
```

To associate an XML schema name with the external file that contains the schema, code the `XML-SCHEMA` clause in the `SPECIAL-NAMES` paragraph, specifying either a literal or a user-defined word to identify the file.

For example, you can associate the XML schema name `schema-name` shown in the fragment above with the `ddname` `DDSCHEMA` by coding the `ddname` as a literal in the `XML-SCHEMA` clause as follows:

```
ENVIRONMENT DIVISION.
CONFIGURATION SECTION.
SPECIAL-NAMES.
    XML-SCHEMA schema-name IS 'DDSCHEMA'.
```

For running the program, you can associate ddname DDSHEMA with the z/OS UNIX file item.osr by coding a DD statement as follows:

```
//GO.DDSHEMA DD PATH='/u/HLQ/xml/item.osr'
```

Or you can use an analogous TSO ALLOCATE command.

Alternatively, DDSHEMA in the example above could be the name of an environment variable that identifies the external file by means of a DSN option that specifies an MVS data set or a PATH option that specifies a z/OS UNIX file.

If your schema is in an MVS data set, the data set can be any sequential data set (for example, QSAM fixed blocked or variable blocked, or VSAM ESDS).

For further details about how to associate an XML schema name with the external file that contains the schema, see the related reference about the XML-SCHEMA clause.

Restriction: XML validation using the FILE keyword is not supported under CICS.

The automatic retrieval that occurs when you use the FILE keyword is convenient. But if you have several XML documents of the same type to validate, reading the schema into memory once and then reusing the schema for each of the documents provides better performance than automatic retrieval. In this case, you use the other form of the VALIDATING phrase, in which you specify an identifier that references an alphanumeric data item that contains the XML schema. For example:

```
XML PARSE document-item
    VALIDATING WITH xmlschema
    PROCESSING PROCEDURE xml-event-handler
    ON EXCEPTION
    DISPLAY 'Document has an error.'
    GOBACK
    NOT ON EXCEPTION
    DISPLAY 'Document is valid.'
END-XML
```

Read the preprocessed schema into the data item, for example by using normal COBOL statements.

For more information about this form of the VALIDATING phrase, see the related reference about the XML PARSE statement.

During parsing with validation, normal XML events are returned until an exception occurs due to a validation error or well-formedness error. If an XML document is not valid, the parser signals an XML exception and passes control to the processing procedure with special register XML-EVENT containing 'EXCEPTION' and special register XML-CODE containing return code 24 in the high-order halfword and a specific validation reason code in the low-order halfword.

For information about the return code and reason code for exceptions that might occur when parsing XML documents with validation, see the related reference about exceptions with XMLPARSE(XMLSS) in effect.

“Example: parsing XML documents with validation” on page 568

RELATED CONCEPTS

“XML-CODE” on page 535

“XML schemas” on page 542

RELATED TASKS

“Handling XML PARSE exceptions” on page 552

RELATED REFERENCES

“XMLPARSE” on page 373 (compiler option)

“XML PARSE exceptions with XMLPARSE(XMLSS) in effect” on page 701

XML PARSE statement (*Enterprise COBOL Language Reference*)

XML-SCHEMA clause (*Enterprise COBOL Language Reference*)

z/OS XML System Services User's Guide and Reference

XML schemas

An *XML schema* is a mechanism, defined by the W3C, for describing and constraining the structure and content of XML documents. An XML schema, which is itself expressed in XML, effectively defines a class of XML documents of a given type, for example, purchase orders.

For Enterprise COBOL, XML schemas used for validating XML documents must be in a preprocessed format known as *Optimized Schema Representation (OSR)*. For information about this format, see the related reference about z/OS XML System Services.

Consider an XML document that describes an item for stock-keeping purposes:

```
<stockItem itemNumber="453-SR">
  <itemName>Stainless steel rope thimbles</itemName>
  <quantityOnHand>23</quantityOnHand>
</stockItem>
```

The example document above is both well formed and valid according to the following schema. (The numbers that precede each line are not part of the schema, but are used in the explanations after the schema.)

```
1. <xsd:schema xmlns:xsd="http://www.w3.org/2001/XMLSchema">
2.
3.   <xsd:element name="stockItem" type="stockItemType"/>
4.
5.   <xsd:complexType name="stockItemType">
6.     <xsd:sequence>
7.       <xsd:element name="itemName" type="xsd:string" minOccurs="0"/>
8.       <xsd:element name="quantityOnHand">
9.         <xsd:simpleType>
10.          <xsd:restriction base="xsd:nonNegativeInteger">
11.            <xsd:maxExclusive value="100"/>
12.          </xsd:restriction>
13.        </xsd:simpleType>
14.      </xsd:element>
15.    </xsd:sequence>
16.    <xsd:attribute name="itemNumber" type="SKU" use="required"/>
17.  </xsd:complexType>
18.
19.  <xsd:simpleType name="SKU">
20.    <xsd:restriction base="xsd:string">
21.      <xsd:pattern value="\d{3}-[A-Z]{2}"/>
22.    </xsd:restriction>
23.  </xsd:simpleType>
24.
25. </xsd:schema>
```

The schema declares (line 3) that the root element is `stockItem`, which has a mandatory `itemNumber` attribute (line 16) of type `SKU`, and includes a sequence (lines 6 - 15) of other elements:

- An optional `itemName` element of type `string` (line 7)

- A required `quantityOnHand` element that has a constrained range of 1 - 99 based on the type `nonNegativeInteger` (lines 8 - 14)

Type declarations can be inline and unnamed, as in lines 9 - 13, which include the `maxExclusive` facet to specify the legal values for the `quantityOnHand` element.

For the `itemNumber` attribute, by contrast, the named type `SKU` is declared separately in lines 19 - 23, which include a pattern facet that uses regular expression syntax to specify that the legal values for that type consist of (in order): 3 digits, a hyphen-minus, then two uppercase letters.

The example referenced below shows a program that parses documents against this schema.

“Example: parsing XML documents with validation” on page 568

RELATED TASKS

“Parsing XML documents with validation” on page 540

RELATED REFERENCES

z/OS XML System Services User's Guide and Reference

Parsing XML documents one segment at a time

You can parse XML documents by passing the parser one *segment* (or record) of XML text at a time. Processing very large documents, or processing XML documents that reside in a data set, are two possible major applications of this technique.

To use this feature, compile your program with the `XMLPARSE(XMLSS)` compiler option in effect.

You parse an XML document a segment at a time by initializing the parse data item to the first segment of the XML document, and then executing the `XML PARSE` statement. The parser processes the XML text and returns XML events to your processing procedure as usual.

At the end of the text segment, the parser signals an `END-OF-INPUT XML` event, with `XML-CODE` set to zero. If there is another segment of the document to process, in your processing procedure move the next segment of XML data to the parse data item, set `XML-CODE` to one, and return to the parser. To signal the end of XML segments to the parser, return to the parser with `XML-CODE` still set to zero.

The length of the parse data item is evaluated for each segment, and determines the segment length.

Variable-length segments: If the XML document segments are variable length, specify a variable-length item for the parse data item. For example, for variable-length XML segments, you can define the parse data item as one of the following items:

- A variable-length group item that contains an `OCCURS DEPENDING ON` clause
- A reference-modified item
- An FD record that specifies the `RECORD IS VARYING DEPENDING ON` clause, where the depending-on data item is used as the length in a reference modifier or ODO object for the FD record

When you send an XML document to the parser in multiple segments, document content is in some cases returned to the processing procedure in multiple fragments by means of multiple events, rather than as one large fragment in a single event.

For example, if the document is split into two segments with the split point in the middle of a string of content characters, the parser returns the content in two separate CONTENT-CHARACTERS events. In the processing procedure, you must reassemble the string of content as needed by the application.

Starting element tags, attribute names, namespace declarations, and ending element tags are always delivered to the processing procedure in a single event, even if those items are split between two segments of a document.

If a segment split occurs between the bytes of a multibyte character, the parser detects the split and reassembles the character for delivery in a single event.

If you are parsing an XML document with an unknown number of repetitive elements to be processed, use unbounded tables. For more information on unbounded tables, see “Working with unbounded tables and groups” on page 90.

For each such element in a given document, manage the table size using one of the following methods:

- Calculating number of elements:
 1. Count the number of elements in the document during an initial parse.
 2. Set the OCCURS DEPENDING ON object for the table to that size
 3. Allocate storage for the table
 4. Parse the document a second time to process the XML
- Incremental expansion:
 1. Set an initial size in the OCCURS DEPENDING ON object for the unbounded table
 2. Parse the document normally. For each element
 - a. Check the limit and expand the unbounded table if necessary.
 3. Allocate a new, larger storage area:
 4. Copy the data from the smaller area
 5. Free the smaller area
 6. Set the table pointer to the address of the larger storage area.

QSAM and VSAM files: You can process XML documents stored in a QSAM or VSAM file as follows:

1. Open the file and read the first record of the XML document.
2. Execute the XML PARSE statement with the FD record as the parse data item.
3. In the processing-procedure logic for handling the END-OF-INPUT event, read the next record of the XML document into the parse data item. If not end-of-file (file status code 10), set XML-CODE to one and return to the parser. If end-of-file, return to the parser with XML-CODE still set to zero.
4. In your processing procedure logic for the END-OF-DOCUMENT event, close the file.

Miscellaneous information after the root element:

The root element of an XML document might be followed by zero or more occurrences of a comment or processing instruction, in any order. If you parse the document one segment at a time, the parser signals an END-OF-INPUT XML event

after processing the end tag of the root element only if the last item in the segment is incomplete. If the segment ends with a complete XML item (such as the root element end tag, or after that tag, a complete comment or processing instruction), the next XML event after the event for the item itself is the END-OF-DOCUMENT XML event.

Tip: To provide successive segments of XML data after the end of the root element, include at least the first non-space character of an XML item at the end of each segment. Include a complete item only on the last segment that you want the parser to process.

For instance, in the following example, in which each line represents a segment of an XML document, the segment that includes the text `This comment ends this` segment is the last segment to be parsed:

```
<Tagline>  
COBOL is the language of the future!  
</Tagline> <  
!--First comment--  
> <?pi data?> <!--  
-This comment ends this segment-->  
<!-- This segment is not included in the parse-->
```

“Example: parsing an XML document one segment at a time” on page 566

RELATED CONCEPTS

“XML events” on page 534

“XML-CODE” on page 535

RELATED TASKS

“Parsing XML documents one segment at a time” on page 543

“XML-CODE” on page 535

RELATED REFERENCES

“XMLPARSE” on page 373 (compiler option)

Handling splits using the XML-INFORMATION special register

You can parse large XML documents by using the XML-INFORMATION special register.

To use this feature, compile your program with the XMLPARSE(XMLSS) compiler option in effect.

Splits in character content might occur at arbitrary points in the XML data stream, even with unsegmented input. The XML-INFORMATION special register simplifies the reassembly of content. This register may be required for any and all attribute values and element character content.

The length of the parse data item is evaluated for each segment, and determines the segment length.

The example, “Example: program for processing XML” on page 558, demonstrates various ways of assigning values obtained from the XML document to program data items for later processing.

The XML data is provided to the parser in 40-byte records, imitating the way an XML document might be acquired from an external source such as a data file. The

record boundaries are designed so that all data splits but one are accommodated by the parser. For example, the sample treats as an error a split in any content except the content of the "filling" element.

In the example, the XML-INFORMATION special register is only used to simplify the reassembly of content for the "filling" element. This register could be used for any attribute values and element character content. An XML-INFORMATION value of 2 indicates that the character data for an ATTRIBUTE-CHARACTERS or CONTENT-CHARACTERS XML event is continued in a subsequent XML event, and should thus be buffered in order to accumulate the complete character string. A subsequent XML event of the same type with an XML-INFORMATION value of 1 indicates that XML-TEXT or XML-NTEXT contains the final piece of the character content, and that the complete string can be moved to the appropriate data item.

In the example, the STRING ... WITH POINTER statement accumulates and describes properly the complete character value for assignment to the "filling" identifier.

```
String xml-text delimited by size into
  content-buffer with pointer tally
On overflow
  Display 'content buffer ('
    length of content-buffer
    ' bytes) is too small'
  Move -1 to xml-code
End-string
```

RELATED CONCEPTS

"XML events" on page 534

"XML-CODE" on page 535

RELATED REFERENCES

"XMLPARSE" on page 373 (compiler option)

"Example: program for processing XML" on page 558

The encoding of XML documents

XML documents must be encoded in a supported code page.

XML documents generated in or parsed from national data items must be encoded in Unicode UTF-16 in big-endian format, CCSID 1200.

For XML GENERATE statements, documents generated in alphanumeric data items must be encoded in Unicode UTF-8 (CCSID 1208) or one of the single-byte EBCDIC encodings listed in the table below. You can use any CCSID from that table in the ENCODING phrase of the XML GENERATE statement.

For XML PARSE statements, documents in alphanumeric data items must be encoded as follows:

- If XMLPARSE (XMLSS) is in effect:
 - If the RETURNING NATIONAL phrase is specified in the XML PARSE statement, in any EBCDIC or ASCII encoding that is supported by z/OS Unicode Services for conversion to UTF-16
 - If the RETURNING NATIONAL phrase is not specified in the XML PARSE statement, in UTF-8 (CCSID 1208) or one of the single-byte EBCDIC encodings listed in the table below

- If XMLPARSE (COMPAT) is in effect: in one of the single-byte EBCDIC encodings listed in the table below

If XMLPARSE (XMLSS) is in effect, you can use any supported CCSID (as described above for XML PARSE) in the ENCODING phrase of the XML PARSE statement.

Table 67. Coded character sets for XML documents

CCSID	Description
1208	UTF-8 ¹
1047	Latin 1 / Open Systems
1140, 37	USA, Canada, . . . Euro Country Extended Code Page (ECECP), Country Extended Code Page (CECP)
1141, 273	Austria, Germany ECECP, CECP
1142, 277	Denmark, Norway ECECP, CECP
1143, 278	Finland, Sweden ECECP, CECP
1144, 280	Italy ECECP, CECP
1145, 284	Spain, Latin America (Spanish) ECECP, CECP
1146, 285	UK ECECP, CECP
1147, 297	France ECECP, CECP
1148, 500	International ECECP, CECP
1149, 871	Iceland ECECP, CECP
1. Supported for the XML PARSE statement in the ENCODING phrase if XMLPARSE (XMLSS) is in effect	

RELATED CONCEPTS

“XML input document encoding”

RELATED TASKS

“Specifying the encoding” on page 549

“Parsing XML documents encoded in UTF-8” on page 551

Chapter 29, “Producing XML output,” on page 571

RELATED REFERENCES

“CODEPAGE” on page 313

“XMLPARSE” on page 373 (compiler option)

XML input document encoding

To parse an XML document using the XML PARSE statement, the document must be encoded in a supported encoding.

The supported encodings for a given parse operation depend on:

- The category of the data item that contains the XML document
- The setting of the XMLPARSE compiler option
- The optional phrases that are specified in the XML PARSE statement

For XML documents that are contained in a national data item, the supported encoding is Unicode UTF-16 in big-endian format, CCSID 1200.

For XML documents that are contained in an alphanumeric data item, the supported encodings if the XMLPARSE(XMLSS) compiler option is in effect are as follows:

- If the RETURNING NATIONAL phrase is specified in the XML PARSE statement: UTF-8 or any EBCDIC or ASCII encoding that is supported by the z/OS Unicode Services for conversion to UTF-16
- If the RETURNING NATIONAL phrase is not specified: UTF-8 or any of the single-byte EBCDIC CCSIDs listed in the related reference about the encoding of XML documents

For XML documents that are contained in an alphanumeric data item, the supported CCSIDs if XMLPARSE(COMPAT) is in effect are those specified in the related reference about the encoding of XML documents.

To parse an XML document that is encoded in an unsupported code page, first convert the document to national character data (UTF-16) by using the NATIONAL-OF intrinsic function. You can convert the individual pieces of document text that are passed to the processing procedure in special register XML-NTEXT back to the original code page by using the DISPLAY-OF intrinsic function.

XML declaration and white space:

XML documents can begin with *white space* only if they do not have an XML declaration:

- If an XML document begins with an XML declaration, the first angle bracket (<) in the document must be the first character in the document.
- If an XML document does not begin with an XML declaration, the first angle bracket in the document can be preceded only by white space.

White-space characters have the hexadecimal values shown in the following table.

Table 68. Hexadecimal values of white-space characters

White-space character	EBCDIC	Unicode
Space	X'40'	X'0020'
Horizontal tabulation	X'05'	X'0009'
Carriage return	X'0D'	X'000D'
Line feed	X'25'	X'000A'
New line / next line	X'15'	X'0085'

Determining the encoding of an input XML document

The parser must know the encoding of an XML document in order to process the document correctly.

If the specified encoding is not one of the supported coded character sets, the parser signals an XML exception event before beginning the parse operation. If the *actual document encoding* does not match the specified encoding, the parser signals an appropriate XML exception after beginning the parse operation.

Several sources are used in determining the encoding of an XML document:

- If the XMLPARSE(XMLSS) option is in effect:
 - The data type of the data item that contains the XML document
 - The ENCODING phrase (if used) of the XML PARSE statement

- The CCSID specified in the CODEPAGE compiler option
- If the XMLPARSE (COMPAT) option is in effect:
 - The data type of the data item that contains the XML document
 - The actual encoding determined when the parser examines the first few bytes of the document
 - The *encoding declaration* specified within the XML document
 - The CCSID specified in the CODEPAGE compiler option

If XMLPARSE (XMLSS) is in effect:

- Any encoding declaration specified within the XML document is ignored.
- For XML documents that are contained in a national data item, the ENCODING phrase of the XML PARSE statement must be omitted or must specify CCSID 1200. The CCSID specified in the CODEPAGE compiler option is ignored. The parser signals an XML exception event if the actual document encoding is not UTF-16 in big-endian format.
- For XML documents that are contained in an alphanumeric data item, the CCSID specified in the ENCODING phrase overrides the CODEPAGE compiler option. The parser raises an XML exception event at the beginning of the parse operation if the actual document encoding is not consistent with the specified CCSID.

RELATED TASKS

“Converting to or from national (Unicode) representation” on page 137

“Specifying the encoding”

“Parsing XML documents encoded in UTF-8” on page 551

“Handling XML PARSE exceptions” on page 552

RELATED REFERENCES

“XMLPARSE” on page 373 (compiler option)

“The encoding of XML documents” on page 546

“EBCDIC code-page-sensitive characters in XML markup” on page 550

Specifying the encoding

You can choose how to specify the encoding for parsing an XML document that is in an alphanumeric data item.

The preferred way is to omit the encoding declaration from the document and to specify the encoding using one of the following means:

- If XMLPARSE (XMLSS) is in effect: the ENCODING phrase of the XML PARSE statement, or the CODEPAGE compiler option
- If XMLPARSE (COMPAT) is in effect: the CODEPAGE compiler option

Omitting the encoding declaration makes it possible to more easily transmit an XML document between heterogeneous systems. (If you included an encoding declaration, you would need to update it to reflect any code-page translation imposed by the transmission process.)

For XMLPARSE (COMPAT):

You can instead specify an encoding declaration in the XML declaration with which most XML documents begin. For example:

```
<?xml version="1.0" encoding="ibm-1140"?>
```

Note that the XML parser generates an exception if it encounters an XML declaration that does not begin in the first byte of an XML document.

If you specify an encoding declaration, do so in one of the following ways:

- Specify the CCSID number (with or without any number of leading zeros) prefixed by one of the following strings in any mixture of uppercase and lowercase letters:
 - IBM-
 - IBM_
 - CCSID-
 - CCSID_
- Use one of the aliases listed in the following table. You can code the aliases in any mixture of uppercase and lowercase letters.

Table 69. Aliases for XML encoding declarations

CCSID	Supported aliases
037	EBCDIC-CP-US, EBCDIC-CP-CA, EBCDIC-CP-WT, EBCDIC-CP-NL
500	EBCDIC-CP-BE, EBCDIC-CP-CH
1200	UTF-16
1208	UTF-8

For more information about the CCSIDs that are supported for XML parsing, see the related reference about the encoding of XML documents.

RELATED CONCEPTS

“XML input document encoding” on page 547

RELATED TASKS

“Parsing XML documents encoded in UTF-8” on page 551

“Handling encoding conflicts” on page 555

RELATED REFERENCES

“The encoding of XML documents” on page 546

EBCDIC code-page-sensitive characters in XML markup

Several special characters that are used in XML markup have different hexadecimal representations in different EBCDIC code pages.

The following table shows those special characters and their hexadecimal values for various EBCDIC CCSIDs.

Table 70. Hexadecimal values of special characters for various EBCDIC CCSIDs

Character	1047	1140	1141	1142	1143	1144	1145	1146	1147	1148	1149
[X'AD'	X'BA'	X'63'	X'9E'	X'B5'	X'90'	X'4A'	X'B1'	X'90'	X'4A'	X'AE'
]	X'BD'	X'BB'	X'FC'	X'9F'	X'9F'	X'51'	X'5A'	X'BB'	X'B5'	X'5A'	X'9E'
!	X'5A'	X'5A'	X'4F'	X'4F'	X'4F'	X'4F'	X'BB'	X'5A'	X'4F'	X'4F'	X'4F'
	X'4F'	X'4F'	X'BB'	X'BB'	X'BB'	X'BB'	X'4F'	X'4F'	X'BB'	X'BB'	X'BB'
#	X'7B'	X'7B'	X'7B'	X'4A'	X'63'	X'B1'	X'69'	X'7B'	X'B1'	X'7B'	X'7B'

Parsing XML documents encoded in UTF-8

If the XMLPARSE(XMLSS) compiler option is in effect, you can parse XML documents that are encoded in Unicode UTF-8 in a manner similar to parsing other XML documents. However, some additional requirements apply.

To parse a UTF-8 XML document, you must specify CCSID 1208 in the ENCODING phrase of the XML PARSE statement, as shown in the following code fragment:

```
XML PARSE xml-document
    WITH ENCODING 1208
    PROCESSING PROCEDURE xml-event-handler
    . . .
END-XML
```

You define xml-document as an alphanumeric data item or alphanumeric group item in WORKING-STORAGE or LOCAL-STORAGE.

If you do not code the RETURNING NATIONAL phrase in the XML PARSE statement, the parser returns the XML document fragments in the alphanumeric special registers XML-TEXT, XML-NAMESPACE, and XML-NAMESPACE-PREFIX.

UTF-8 characters are encoded using a variable number of bytes per character. Most COBOL operations on alphanumeric data assume a single-byte encoding, in which each character is encoded in 1 byte. When you operate on UTF-8 characters as alphanumeric data, you must ensure that the data is processed correctly. Avoid operations (such as reference modification and moves that involve truncation) that can split a multibyte character between bytes. You cannot reliably use statements such as INSPECT to process multibyte characters in alphanumeric data.

You can more reliably process UTF-8 document fragments by specifying the RETURNING NATIONAL phrase in the XML PARSE statement. If you use the RETURNING NATIONAL phrase, XML document fragments are efficiently converted to UTF-16 encoding and are returned to the application in the national special registers XML-NTEXT, XML-NNAMESPACE, and XMLNNAMESPACE-PREFIX. Then you can process the XML text fragments in national data items. (The UTF-16 encoding in national data items greatly facilitates Unicode processing in COBOL.)

The following code fragment illustrates the use of both the ENCODING phrase and the RETURNING NATIONAL phrase for parsing a UTF-8 XML document:

```
XML PARSE xml-document
    WITH ENCODING 1208 RETURNING NATIONAL
    PROCESSING PROCEDURE xml-event-handler
    ON EXCEPTION
        DISPLAY 'XML document error ' XML-CODE
        STOP RUN
    NOT ON EXCEPTION
        DISPLAY 'XML document was successfully parsed.'
END-XML
```

RELATED CONCEPTS

“XML-TEXT and XML-NTEXT” on page 537

“XML-NAMESPACE and XML-NNAMESPACE” on page 537

“XML-NAMESPACE-PREFIX and XML-NNAMESPACE-PREFIX” on page 538

RELATED TASKS

“Processing UTF-8 data” on page 141

“Parsing XML documents” on page 530

“Specifying the encoding” on page 549

RELATED REFERENCES

"XMLPARSE" on page 373 (compiler option)

"The encoding of XML documents" on page 546

XML PARSE statement (*Enterprise COBOL Language Reference*)

Handling XML PARSE exceptions

If the XML parser encounters an anomaly or error during parsing, it sets an exception code in the XML-CODE special register and signals an XML exception event. The specific exception codes that can occur and the subsequent actions that you can take differ depending on the setting of the XMLPARSE compiler option.

For XMLPARSE(XMLSS):

Return code and reason code: The exception code is formed from the return code and the reason code that the parser generates. The return code and the reason code are each a halfword binary value. The value in XML-CODE is a concatenation of these two values.

As an example, the following XML document is not well formed because the element end tag `mmsg` does not match the element start tag `msg`:

```
<msg>Hello</mmsg>
```

The return code is hexadecimal 000C (XRC_NOT_WELL_FORMED), and the reason code is hexadecimal 3035 (XRSN_ENDTAG_NAME_MISMATCH), if you parse the document without validation. The concatenation of these two values, hexadecimal 000C3035, is returned to the processing procedure in the XML-CODE special register.

If you parse a document with validation, the values returned in XML-CODE for any well-formedness errors differ from the values returned for the same errors when you parse without validation. The return code generated by the z/OS XML System Services parser for any validation error is 24 (hexadecimal 0018).

For more information about the return codes and reason codes that can be generated, see the related reference about exceptions with XMLPARSE(XMLSS) in effect.

If XMLPARSE(XMLSS) is in effect, processing procedures cannot handle exception events and cannot cause parsing to resume. When a processing procedure returns to the parser from an exception event, the parser does not signal any further events. The parser transfers control to the statement that is specified in the ON EXCEPTION phrase of the XML PARSE statement. If you did not code an ON EXCEPTION phrase, control is passed to the end of the XML PARSE statement. XML-CODE contains the original exception code set by the parser.

If no exception occurs during parsing, control is passed to the statement specified in the NOT ON EXCEPTION phrase. If you did not code a NOT ON EXCEPTION phrase, control is passed to the end of the XML PARSE statement. XML-CODE contains zero.

For XMLPARSE(COMPAT):

If the exception code is within a certain range, you might be able to handle the exception event within your processing procedure, and resume parsing.

To handle an exception in the processing procedure, follow these steps:

1. Check the contents of XML-CODE.
2. Handle the exception appropriately.
3. Set XML-CODE to zero to indicate that you handled the exception.
4. Return control to the parser.

The exception condition no longer exists.

You can handle exceptions in this way only if the exception code that is passed in XML-CODE is within one of the following ranges, which indicates that an encoding conflict was detected:

- 50 - 99
- 100,001 - 165,535

Exception codes 1 - 49: In the processing procedure, you can do limited handling of exceptions for which the exception code is within the range 1 - 49. After an exception in this range occurs, the parser does not signal any further normal events, except the END-OF-DOCUMENT event, even if you set XML-CODE to zero before returning. If you set XML-CODE to zero, the parser continues parsing the document and signals any exceptions that it finds. (Doing so can provide a useful way to discover multiple errors in the document.)

Restriction: The compatibility-mode COBOL XML parser might not signal all additional exception events. The number of exceptions is limited to the remaining space in the XML PARSE event token array, probably 8192 events.

At the end of parsing after an exception that has an exception code in the range 1 - 49, control is passed to the statement specified in the ON EXCEPTION phrase. If you did not code an ON EXCEPTION phrase, control is passed to the end of the XML PARSE statement. XML-CODE contains the code set by the parser for the most recent exception.

For all exceptions other than those having an exception code within one of the ranges described above, the parser does not signal any further events, but passes control to the statement specified in the ON EXCEPTION phrase. XML-CODE contains the original exception code even if you set XML-CODE in the processing procedure before returning control to the parser.

If you do not want to handle an exception, return control to the parser without changing the value of XML-CODE. The parser transfers control to the statement specified in the ON EXCEPTION phrase. If you did not code an ON EXCEPTION phrase, control is transferred to the end of the XML PARSE statement.

If no unhandled exceptions occur before the end of parsing, control is passed to the statement specified in the NOT ON EXCEPTION phrase. If you did not code a NOT ON EXCEPTION phrase, control is transferred to the end of the XML PARSE statement. XML-CODE contains zero.

RELATED CONCEPTS

“XML-CODE” on page 535

“XML input document encoding” on page 547

“How the XML parser handles errors” on page 554

RELATED TASKS

“Writing procedures to process XML” on page 532

“Parsing XML documents with validation” on page 540
“Handling encoding conflicts” on page 555

RELATED REFERENCES

“XMLPARSE” on page 373 (compiler option)
“The encoding of XML documents” on page 546
“XML PARSE exceptions with XMLPARSE(XMLSS) in effect” on page 701
“XML PARSE exceptions with XMLPARSE(COMPAT) in effect” on page 703
z/OS XML System Services User’s Guide and Reference

How the XML parser handles errors

When the XML parser detects an error in an XML document, it generates an XML exception event and passes control to your processing procedure.

The parser passes the following information in special registers to the processing procedure:

- XML-EVENT contains 'EXCEPTION'.
- XML-CODE contains a numeric exception code.
The exception codes are described in the related references about XML PARSE exceptions.
- For fatal exceptions, XML-TEXT or XML-NTEXT contains the document text up to and including the point where the exception was detected.
- For the warning exceptions issued for using an undeclared prefix, XML-TEXT or XML-NTEXT contains the fully qualified attribute name or element name. That is, the name includes the undeclared prefix and the separator colon (:).
- If XMLPARSE(COMPAT) is in effect, XML-TEXT or XML-NTEXT contains the document text up to and including the point where the exception was detected.
- If XMLPARSE(XMLSS) is in effect, XML-TEXT or XML-NTEXT contains the document text up to the point where the error or anomaly was detected. If you process the XML document one segment at a time, the applicable special register contains only the current segment.

All other XML special registers are empty with length zero.

For XMLPARSE(XMLSS):

Parsing cannot continue after a fatal exception even if you set XML-CODE to zero in the processing procedure. Upon return to the parser from the processing procedure, the parser transfers control to the ON EXCEPTION phrase, if specified; otherwise the parser transfers control to the end of the XML PARSE statement. XML-CODE contains the original exception code set by the parser.

For XMLPARSE(COMPAT):

The processing procedure might be able to handle an exception so that parsing continues if the exception code is within one of the following ranges:

- 1 - 99
- 100,001 - 165,535

If the exception code has any other nonzero value, parsing cannot continue.

Encoding conflicts: The exceptions for encoding conflicts (50 - 99 and 300 - 399) are signaled before the parsing of the document begins. For these exceptions, XML-TEXT or XML-NTEXT is either length zero or contains only the encoding declaration value from the document.

Exception codes 1 - 49: An exception for which the exception code is in the range 1 - 49 is a fatal error according to the *XML specification*. Therefore, the parser does not continue normal parsing even if the processing procedure handles the exception. However, the parser does continue scanning for further errors until it reaches the end of the document, or until the existing XML EVENT token array is exhausted. For these exceptions, the parser does not signal any further normal events except the END-OF-DOCUMENT event.

RELATED CONCEPTS

"XML events" on page 534

"XML-CODE" on page 535

"XML input document encoding" on page 547

RELATED TASKS

"Parsing XML documents one segment at a time" on page 543

"Handling XML PARSE exceptions" on page 552

"Handling encoding conflicts"

"Terminating XML parsing" on page 556

RELATED REFERENCES

"XMLPARSE" on page 373 (compiler option)

"The encoding of XML documents" on page 546

"XML PARSE exceptions with XMLPARSE(XMLSS) in effect" on page 701

"XML PARSE exceptions with XMLPARSE(COMPAT) in effect" on page 703

z/OS XML System Services User's Guide and Reference

XML specification

Handling encoding conflicts

The way that you handle encoding-conflict exceptions depends on the setting of the XMLPARSE compiler option.

For XMLPARSE(XMLSS):

The parser does not continue after an encoding-conflict exception or after any other type of exception. Any changes that you make in the processing procedure to the value of XML-CODE are ignored. The value in XML-CODE when the parser returns to the XML PARSE statement is the original exception code that the parser set.

For XMLPARSE(COMPAT):

Your processing procedure might be able to handle exceptions for document encoding conflicts. Exception events in which the parse data item is alphanumeric and the exception code in XML-CODE is within the range 100,001 - 165,535 indicate that the code page of the document (as specified by its encoding declaration) conflicts with the external code-page information.

In this special case, you can choose to parse using the code page of the document by subtracting 100,000 from the value in XML-CODE. For instance, if XML-CODE

contains 101,140, the code page of the document is 1140. Alternatively, you can choose to parse using the *external code page* by setting XML-CODE to zero before returning to the parser.

The parser takes one of three actions after returning from a processing procedure for an encoding-conflict exception event:

- If you set XML-CODE to zero, the parser uses the external code page: the value of the CODEPAGE compiler option.
- If you set XML-CODE to the code page of the document (that is, the original XML-CODE value minus 100,000), the parser uses the code page of the document. This is the only case in which the parser continues when XML-CODE has a nonzero value upon returning from a processing procedure.
- Otherwise, the parser stops processing the document and returns control to the XML PARSE statement with an exception condition. XML-CODE contains the exception code that was originally passed with the exception event.

RELATED CONCEPTS

“XML-CODE” on page 535

“XML input document encoding” on page 547

“How the XML parser handles errors” on page 554

RELATED TASKS

“Handling XML PARSE exceptions” on page 552

RELATED REFERENCES

“XMLPARSE” on page 373 (compiler option)

“The encoding of XML documents” on page 546

“XML PARSE exceptions with XMLPARSE(XMLSS) in effect” on page 701

“XML PARSE exceptions with XMLPARSE(COMPAT) in effect” on page 703

z/OS XML System Services User's Guide and Reference

Terminating XML parsing

You can terminate parsing immediately, without processing any remaining XML text, by setting XML-CODE to -1 in your processing procedure before the procedure returns to the parser from any normal XML event (that is, any event other than EXCEPTION).

You can use this technique when the processing procedure has examined enough of the document or has detected some irregularity in the document that precludes further meaningful processing.

If you terminate parsing in this way, the parser does not signal any further XML events, including the exception event. Control transfers to the ON EXCEPTION phrase of the XML PARSE statement, if that phrase was specified.

In the imperative statement of the ON EXCEPTION phrase, you can determine whether parsing was deliberately terminated by testing whether XML-CODE contains -1. If you do not specify the ON EXCEPTION phrase, control transfers to the end of the XML PARSE statement.

If the XMLPARSE(COMPAT) compiler option is in effect, you can also terminate parsing after any XML EXCEPTION event by returning to the parser from the processing procedure without changing the value in XML-CODE. The result is similar to the

result of deliberate termination, except that the parser returns to the XML PARSE statement with XML-CODE containing the original exception code.

If the XMLPARSE(XMLSS) option is in effect, parsing always terminates after any exception event.

RELATED CONCEPTS

“XML-CODE” on page 535

“How the XML parser handles errors” on page 554

RELATED TASKS

“Writing procedures to process XML” on page 532

“Handling XML PARSE exceptions” on page 552

XML PARSE examples

The examples that are referenced below illustrate various uses of the XML PARSE statement.

Use these examples to understand the basic use of XML PARSE and for XMLPARSE(XMLSS), specialized uses such as parsing documents that include namespaces, parsing documents one segment at a time, and parsing documents with validation against a schema.

“Example: parsing a simple document”

“Example: program for processing XML” on page 558

“Example: parsing an XML document that uses namespaces” on page 563

“Example: parsing an XML document one segment at a time” on page 566

“Example: parsing XML documents with validation” on page 568

Example: parsing a simple document

This example shows the flow of events and the contents of special register XML-TEXT that result from the parsing of a simple XML document.

Assume that the COBOL program contains the following XML document in data item Doc:

```
<?xml version="1.0"?><msg type="short">Hello, World!</msg>
```

The following code fragment shows an XML PARSE statement for parsing Doc, and a processing procedure, P, for handling the XML events:

```
XML Parse Doc
  Processing procedure P
  .
  .
  .
P. Display XML-Event XML-Text.
```

The processing procedure displays the content of XML-EVENT and XML-TEXT for each event that the parser signals during parsing. The following table shows the events and the text.

Table 71. XML events and special registers

XML-EVENT	XML-TEXT
START-OF-DOCUMENT	
VERSION-INFORMATION	1.0
START-OF-ELEMENT	msg

Table 71. XML events and special registers (continued)

XML-EVENT	XML-TEXT
ATTRIBUTE-NAME	type
ATTRIBUTE-CHARACTERS	short
CONTENT-CHARACTERS	Hello, World!
END-OF-ELEMENT	msg
END-OF-DOCUMENT	

RELATED CONCEPTS

“XML events” on page 534

“XML-TEXT and XML-NTEXT” on page 537

Example: program for processing XML

This example shows the parsing of an XML document, and a processing procedure that reports the various XML events and their associated text fragments.

The XML document is shown in the program source to make it easier to follow the flow of the parsing. The output of the program with XMLPARSE(XMLSS) and with XMLPARSE(COMPAT) in effect is shown after the example.

To understand the interaction of the parser and the processing procedure, and to match events to document fragments, compare the XML document to the output of the program.

```

Process codepage(1047)
  Identification division.
  Program-id. XMLSAMPL.
  Data division.
  Working-storage section.
*****
* XML document data, encoded as initial values of data items. *
*****
1 xml-document-data.
2 pic x(39) value '<?xml version="1.0" encoding="IBM-1047"'.
2 pic x(19) value ' standalone="yes"?>'.
2 pic x(39) value '<!--This document is just an example-->'.
2 pic x(10) value '<sandwich>'.
2 pic x(33) value '<bread type="baker&apos;s best"/>'.
2 pic x(36) value '<?spread We'll use real mayonnaise?>'.
2 pic x(29) value '<meat>Ham & turkey</meat>'.
2 pic x(34) value '<filling>Cheese, lettuce, tomato, '.
2 pic x(32) value 'and that's all, Folks!</filling>'.
2 pic x(25) value '<![CDATA[We should add a '.
2 pic x(20) value '<relish> element!]]>'.
2 pic x(28) value '<listprice>$4.99</listprice>'.
2 pic x(25) value '<discount>0.10</discount>'.
2 pic x(31) value '</sandwich>'.
*****
* XML document, represented as fixed-length records. *
*****
1 xml-document redefines xml-document-data.
2 xml-segment pic x(40) occurs 10 times.
1 xml-segment-no comp pic s9(4).
1 content-buffer pic x(100).
1 current-element-stack.
2 current-element pic x(30) occurs 10 times.
*****
* Sample data definitions for processing numeric XML content. *
*****

```

```

1 element-depth comp pic s9(4).
1 discount computational pic 9v99 value 0.
1 display-price pic $$9.99.
1 filling pic x(4095).
1 list-price computational pic 9v99 value 0.
1 ofr-ed pic x(9) justified.
1 ofr-ed-1 redefines ofr-ed pic 999999.99.
Procedure division.
Mainline section.
  Move 1 to xml-segment-no
  Display 'Initial segment {' xml-segment(xml-segment-no) }'
  Display ' '
  XML parse xml-segment(xml-segment-no)
    processing procedure XML-handler
  On exception
    Display 'XML processing error, XML-Code=' XML-Code '.'
    Move 16 to return-code
    Goback
  Not on exception
    Display 'XML document successfully parsed.'
  End-XML
*****
* Process the transformed content and calculate promo price. *
*****
  Display ' '
  Display '-----+++++***** Using information from XML '
    '*****+++++-----'
  Display ' '
  Move list-price to Display-price
  Display ' Sandwich list price: ' Display-price
  Compute Display-price = list-price * (1 - discount)
  Display ' Promotional price: ' Display-price
  Display ' Get one today!'
  Goback.
XML-handler section.
  Evaluate XML-Event
* ==> Order XML events most frequent first
  When 'START-OF-ELEMENT'
    Display 'Start element tag: {' XML-Text }'
    Add 1 to element-depth
    Move XML-Text to current-element(element-depth)
  When 'CONTENT-CHARACTERS'
    Display 'Content characters: {' XML-Text }'
* ==> In general, a split can occur for any element or attribute
* ==> data, but in this sample, it only occurs for "filling"...
  If xml-information = 2 and
    current-element(element-depth) not = 'filling'
    Display 'Unexpected split in content for element '
      current-element(element-depth)
    Move -1 to xml-code
  End-if
* ==> Transform XML content to operational COBOL data item...
  Evaluate current-element(element-depth)
  When 'filling'
* ==> After reassembling separate pieces of character content...
  String xml-text delimited by size into
    content-buffer with pointer tally
  On overflow
    Display 'content buffer ('
      length of content-buffer
      ' bytes) is too small'
    Move -1 to xml-code
  End-string
  Evaluate xml-information
  When 2
    Display ' Character data for element "filling" '
      'is incomplete.'

```

```

        Display ' The partial data was buffered for '
        'content assembly.'
    When 1
        subtract 1 from tally
        move content-buffer(1:tally) to filling
        Display ' Element "filling" data (' tally
        ' bytes) is now complete:'
        Display ' {' filling(1:tally) }'
    End-evaluate
    When 'listprice'
* ==> Using function NUMVAL-C...
        Move XML-Text to content-buffer
        Compute list-price =
            function numval-c(content-buffer)
    When 'discount'
* ==> Using de-editing of a numeric edited item...
        Move XML-Text to ofr-ed
        Move ofr-ed-1 to discount
    End-evaluate
    When 'END-OF-ELEMENT'
        Display 'End element tag: {' XML-Text }'
        Subtract 1 from element-depth
    When 'END-OF-INPUT'
        Display 'End of input'
        Add 1 to xml-segment-no
        Display ' Next segment: {' xml-segment(xml-segment-no)
        '}'
        Display ' '
        Move 1 to xml-code
    When 'START-OF-DOCUMENT'
        Display 'Start of document'
        Move 0 to element-depth
        Move 1 to tally
    When 'END-OF-DOCUMENT'
        Display 'End of document.'
    When 'VERSION-INFORMATION'
        Display 'Version: {' XML-Text }'
    When 'ENCODING-DECLARATION'
        Display 'Encoding: {' XML-Text }'
    When 'STANDALONE-DECLARATION'
        Display 'Standalone: {' XML-Text }'
    When 'ATTRIBUTE-NAME'
        Display 'Attribute name: {' XML-Text }'
    When 'ATTRIBUTE-CHARACTERS'
        Display 'Attribute value characters: {' XML-Text }'
    When 'ATTRIBUTE-CHARACTER'
        Display 'Attribute value character: {' XML-Text }'
    When 'START-OF-CDATA-SECTION'
        Display 'Start of CData section'
    When 'END-OF-CDATA-SECTION'
        Display 'End of CData section'
    When 'CONTENT-CHARACTER'
        Display 'Content character: {' XML-Text }'
    When 'PROCESSING-INSTRUCTION-TARGET'
        Display 'PI target: {' XML-Text }'
    When 'PROCESSING-INSTRUCTION-DATA'
        Display 'PI data: {' XML-Text }'
    When 'COMMENT'
        Display 'Comment: {' XML-Text }'
    When 'EXCEPTION'
        Compute tally = function length (XML-Text)
        Display 'Exception ' XML-Code ' at offset ' tally '.'
    When other
        Display 'Unexpected XML event: ' XML-Event '.'
    End-evaluate
    .
End program XMLSAMPL.

```

Output from parsing with XMLPARSE(XMLSS)

From the following output you can see which fragments of the document were associated with the events that occurred during parsing:

```
Initial segment {<?xml version="1.0" encoding="ibm-1047" }

Start of document
End of input
  Next segment: {standalone="yes"?><!--This document is j}

Version: {1.0}
Encoding: {ibm-1047}
Standalone: {yes}
Comment: {This document is j}
End of input
  Next segment: {ust an example--><sandwich><bread type="}

Comment: {ust an example}
Start element tag: {sandwich}
End of input
  Next segment: {baker&apos;s best"/><?spread We'll use r}

Start element tag: {bread}
Attribute name: {type}
Attribute value characters: {baker's best}
End element tag: {bread}
PI target: {spread}
PI data: {We'll use r}
End of input
  Next segment: {eal mayonnaise?><meat>Ham & turkey</}

PI target: {spread}
PI data: {eal mayonnaise}
Start element tag: {meat}
Content characters: {Ham & turkey}
End of input
  Next segment: {meat}<filling>Cheese, lettuce, tomato, a}

End element tag: {meat}
Start element tag: {filling}
Content characters: {Cheese, lettuce, tomato, a}
  Character data for element "filling" is incomplete.
  The partial data was buffered for content assembly.
End of input
  Next segment: {nd that's all, Folks!</filling><![CDATA[}

Content characters: {nd that's all, Folks!}
  Element "filling" data (00047 bytes) is now complete:
  {Cheese, lettuce, tomato, and that's all, Folks!}
End element tag: {filling}
End of input
  Next segment: {We should add a <relish> element!]}><lis}

Start of CData section
Content characters: {We should add a <relish> element!}
End of CData section
End of input
  Next segment: {tprice>$4.99</listprice><discount>0.10</}

Start element tag: {listprice}
Content characters: {$4.99}
End element tag: {listprice}
Start element tag: {discount}
Content characters: {0.10}
End of input
  Next segment: {discount}</sandwich> }
```

```
End element tag: {discount}
End element tag: {sandwich}
End of document.
XML document successfully parsed.
```

```
-----+***** Using information from XML *****-----
```

```
Sandwich list price: $4.99
Promotional price: $4.49
Get one today!
```

Output from parsing with XMLPARSE (COMPAT)

From the following output you can see which fragments of the document were associated with the events that occurred during parsing:

```
Start of document
Version: {1.0}
Encoding: {IBM-1047}
Standalone: {yes}
Comment: {This document is just an example}
Start element tag: {sandwich}
Content characters: { }
Start element tag: {bread}
Attribute name: {type}
Attribute value characters: {baker}
Attribute value character: {'}
Attribute value characters: {s best}
End element tag: {bread}
Content characters: { }
PI target: {spread}
PI data: {please use real mayonnaise }
Content characters: { }
Start element tag: {meat}
Content characters: {Ham }
Content character: {&}
Content characters: {turkey}
End element tag: {meat}
Content characters: { }
Start element tag: {filling}
Content characters: {Cheese, lettuce, tomato, etc.}
End element tag: {filling}
Content characters: { }
Start of CData: {<![CDATA[}
Content characters: {We should add a <relish> element in future!}
End of CData: {]}>}
Content characters: { }
Start element tag: {listprice}
Content characters: {$4.99 }
End element tag: {listprice}
Content characters: { }
Start element tag: {discount}
Content characters: {0.10}
End element tag: {discount}
End element tag: {sandwich}
End of document.
XML document successfully parsed
```

```
-----+***** Using information from XML *****-----
```

```
Sandwich list price: $4.99
Promotional price: $4.49
Get one today!
```

RELATED CONCEPTS

“XML events” on page 534

RELATED TASKS

“Handling splits using the XML-INFORMATION special register” on page 545

RELATED REFERENCES

“XMLPARSE” on page 373 (compiler option)

XML-EVENT (*Enterprise COBOL Language Reference*)

Example: parsing an XML document that uses namespaces

This example shows the parsing of a document that uses namespaces and namespace prefixes. The program must be compiled using the XMLPARSE(XMLSS) compiler option.

Namespace identifiers and namespace prefixes are used in the program to qualify element names and attribute names. This qualification makes it possible to use the same name in more than one context: title is used both as an author's title (Mr) and as a book title (Writing COBOL for Fun and Profit).

Sample XML document

The following XML document contains several namespace declarations: a default namespace; then three namespace identifiers with prefixes (bk, pi, and isbn). Notice that the default namespace is set to the empty string for the element comment (xmlns=''). This setting “undeclares” the default namespace, with the result that there is no default namespace.

```

<section
  xmlns="http://www.ibm.com/events"
  xmlns:bk="urn:loc.gov:books"
  xmlns:pi="urn:personalInformation"
  xmlns:isbn="urn:ISBN:0-395-36341-6">
  <title>Book-Signing Event</title>
  <signing>
    <bk:author pi:title="Mr" pi:name="Jim Ross"/>
    <book bk:title="Writing COBOL for Fun and Profit" isbn:number="0426070806"/>
    <comment xmlns="">What a great issue!</comment>
  </signing>
</section>

```

Results from parsing

The following table shows the sequence of events that the processing procedure receives from the parser, and shows the content of the associated XML special registers.

Table 72. XML events and special registers

XML-EVENT	XML-TEXT	XML-NAMESPACE-PREFIX	XML-NAMESPACE
START-OF-DOCUMENT			
START-OF-ELEMENT	section		http://www.ibm.com/events
NAMESPACE-DECLARATION			http://www.ibm.com/events
NAMESPACE-DECLARATION		bk	urn:loc.gov:books
NAMESPACE-DECLARATION		pi	urn:personalInformation
NAMESPACE-DECLARATION		isbn	urn:ISBN:0-395-36341-6
START-OF-ELEMENT	title		http://www.ibm.com/events
CONTENT-CHARACTERS	Book-Signing Event		
END-OF-ELEMENT	title		http://www.ibm.com/events
START-OF-ELEMENT	signing		http://www.ibm.com/events

Table 72. XML events and special registers (continued)

XML-EVENT	XML-TEXT	XML-NAMESPACE-PREFIX	XML-NAMESPACE
START-OF-ELEMENT	author	bk	urn:loc.gov:books
ATTRIBUTE-NAME	title	pi	urn:personalInformation
ATTRIBUTE-CHARACTERS	Mr		
ATTRIBUTE-NAME	name	pi	urn:personalInformation
ATTRIBUTE-CHARACTERS	Jim Ross		
END-OF-ELEMENT	author	bk	urn:loc.gov:books
START-OF-ELEMENT	book		http://www.ibm.com/events
ATTRIBUTE-NAME	title	bk	urn:loc.gov:books
ATTRIBUTE-CHARACTERS	Writing COBOL for Fun and Profit		
ATTRIBUTE-NAME	number	isbn	urn:ISBN:0-395-36341-6
ATTRIBUTE-CHARACTERS	0426070806		
END-OF-ELEMENT	book		http://www.ibm.com/events
START-OF-ELEMENT	comment		
NAMESPACE-DECLARATION			
CONTENT-CHARACTERS	What a great issue!		
END-OF-ELEMENT	comment		
END-OF-ELEMENT	signing		http://www.ibm.com/events
END-OF-ELEMENT	section		http://www.ibm.com/events
END-OF-DOCUMENT			

XML PARSE example with an undeclared namespace prefix

The following XML document contains undeclared namespace prefixes:

Identification division.

Program-id. XMLup.

Data division.

Working-storage section.

1 d.

2 pic x(40) value '<pfx0:root xmlns:pfx1="http://whatever">|

2 pic x(19) value '<pfx1:localE1Name1>|

2 pic x(20) value '<pfx2:localE1Name2/>|

2 pic x(40) value '<pfx3:localE1Name3 pfx4:localAtName4="">|

2 pic x(02) value 'c1|

2 pic x(41) value '<pfx5:localE1Name5 pfx6:localAtName6=""/>|

2 pic x(24) value 'c2</pfx3:localE1Name3>c3|

2 pic x(32) value '</pfx1:localE1Name1></pfx0:root>|

Procedure division.

main.

display 'XML document: ' d

display ' '

xml parse d processing procedure h

goback.

h.

if xml-event = 'EXCEPTION'

display ' '

end-if

display xml-event xml-code '|' xml-text '|'

xml-namespace-prefix '|'

xml-namespace '|'

if xml-event = 'EXCEPTION' and xml-code = 264192 or 264193

```

        move 0 to xml-code
    end-if
    .
End program XMLup.

```

Results from parsing XML document with an undeclared namespace prefix

The following table lists the sequence of events that the processing procedure receives from the parser, and shows the content of the associated XML special registers.

Table 73. XML events and special registers from parsing XML document with an undeclared namespace prefix

XML-EVENT	XML-CODE	XML-TEXT	XML-NAMESPACE-PREFIX	XML-NAMESPACE
START-OF-DOCUMENT	000000000			
EXCEPTION	000264193	px0:root		
START-OF-ELEMENT	000000000	root	px0	
NAMESPACE-DECLARATION	000000000		px1	http://whatever
START-OF-ELEMENT	000000000	localE1Name1	px1	http://whatever
EXCEPTION	000264193	px2:localE1Name2		
START-OF-ELEMENT	000000000	localE1Name2	px2	
END-OF-ELEMENT	000000000	localE1Name2	px2	
EXCEPTION	000264193	px3:localE1Name3		
START-OF-ELEMENT	000000000	localE1Name3	px3	
EXCEPTION	000264192	px4:localAtName4		
ATTRIBUTE-NAME	000000000	localAtName4	px4	
ATTRIBUTE-CHARACTERS	000000000			
CONTENT-CHARACTERS	000000000	c1		
EXCEPTION	000264193	px5:localE1Name5		
START-OF-ELEMENT	000000000	localE1Name5	px5	
EXCEPTION	000264192	px6:localAtName6		
ATTRIBUTE-NAME	000000000	localAtName6	px6	
ATTRIBUTE-CHARACTERS	000000000			
END-OF-ELEMENT	000000000	localE1Name5	px5	
CONTENT-CHARACTERS	000000000	c2		
END-OF-ELEMENT	000000000	localE1Name3	px3	
CONTENT-CHARACTERS	000000000	c3		
END-OF-ELEMENT	000000000	localE1Name1	px1	http://whatever
END-OF-ELEMENT	000000000	root	px0	
END-OF-DOCUMENT	000000000			

For a detailed description of the set of XML events, see the related reference about XML-EVENT.

RELATED CONCEPTS

"XML events" on page 534

"XML-TEXT and XML-NTEXT" on page 537

"XML-NAMESPACE and XML-NNAMESPACE" on page 537

"XML-NAMESPACE-PREFIX and XML-NNAMESPACE-PREFIX" on page 538

RELATED REFERENCES

"XMLPARSE" on page 373 (compiler option)

XML-EVENT (*Enterprise COBOL Language Reference*)

Example: parsing an XML document one segment at a time

This example shows the parsing of a document one segment at a time. The program must be compiled using the XMLPARSE(XMLSS) compiler option.

The example shows the XML content of a file, the program that reads and submits XML text to the parser, and the sequence of events that results from parsing the input records.

Content of infile

The XML document that will be parsed a segment at a time is contained in file infile, shown below.

```
<?xml version='1.0'?>
<Tagline>
COBOL is the language of the future!
</Tagline>
```

Program PARSESEG

Program PARSESEG reads a segment (a record) of the XML document from file infile, then passes the record to the parser using the XML PARSE statement. The parser processes the XML text and transfers control to the processing procedure for each XML event. The processing procedure handles each event and returns to the parser.

At the end of the segment, the parser sets XML-EVENT to END-OF-INPUT, sets XML-CODE to zero, and transfers control to the processing procedure. The processing procedure reads the next XML record into the parse data item, sets XML-CODE to one, and returns to the parser.

The exchange between the processing procedure and the parser continues until the READ statement returns the end-of-file status code. The processing procedure returns to the parser with XML-CODE still set to zero to indicate the end of segment processing.

```
Identification division.
Program-id. PARSESEG.
Environment division.
Input-output section.
File-control.
    Select Input-XML
    Assign to infile
    File status is Input-XML-status.
Data division.
File section.
FD Input-XML
    Record is varying from 1 to 255 depending on Rec-length
    Recording mode V.
1 fdrec.
    2 pic X occurs 1 to 255 depending on Rec-length .
Working-storage section.
```

```

1 Event-number comp pic 99.
1 Rec-length comp-5 pic 9(4).
1 Input-XML-status pic 99.
Procedure division.
  Open input Input-XML
  If Input-XML-status not = 0
    Display 'Open failed, file status: ' Input-XML-status
    Goback
  End-if
  Read Input-XML
  If Input-XML-status not = 0
    Display 'Read failed, file status: ' Input-XML-status
    Goback
  End-if
  Move 0 to Event-number
  Display 'Starting with: ' fdrec
  Display 'Event number and name      Content of XML-text'
  XML parse fdrec processing procedure Handle-parse-events
  Close Input-XML
  Goback
.
Handle-parse-events.
  Add 1 to Event-number
  Display ' ' Event-number ': ' XML-event '{' XML-text '}'
  Evaluate XML-event
    When 'END-OF-INPUT'
      Read Input-XML
      Evaluate Input-XML-status
        When 0
          Move 1 to XML-code
          Display 'Continuing with: ' fdrec
        When 10
          Display 'At EOF; no more input.'
        When other
          Display 'Read failed, file status:' Input-XML-status
          Goback
      End-evaluate
    When other
      Continue
  End-evaluate
.
End program PARSESEG.

```

Results from parsing

To show parsing results, the processing procedure displayed each record of input, followed by the sequence of XML events and any associated text fragments in XML-TEXT. The content of XML-TEXT is displayed in braces ({}); empty braces signify that XML-TEXT is empty.

Notice the extra zero-length CONTENT-CHARACTERS XML event at event number 08. (Such anomalies are typical when supplying XML text piecemeal.)

```

Starting with:  <?xml version='1.0'?>
Event number and name      Content of XML-TEXT
01: START-OF-DOCUMENT      {}
02: VERSION-INFORMATION    {1.0}
03: END-OF-INPUT          {}
Continuing with:  <Tagline>
04: START-OF-ELEMENT      {Tagline}
05: END-OF-INPUT          {}
Continuing with:  COBOL is the language of the future!
06: CONTENT-CHARACTERS    {COBOL is the language of the future!}
07: END-OF-INPUT          {}

```

```
Continuing with:  </Tagline>
08: CONTENT-CHARACTERS  {}
09: END-OF-ELEMENT      {Tagline}
10: END-OF-DOCUMENT     {}
```

For a detailed description of the XML events that were detected, see the related reference about XML-EVENT.

RELATED REFERENCES

“XMLPARSE” on page 373 (compiler option)
XML-EVENT (*Enterprise COBOL Language Reference*)

Example: parsing XML documents with validation

This example shows the parsing of several XML documents with validation against a schema, and a processing procedure that captures the return code and reason code that the parser generates after parsing each document. All of the XML documents are well formed but not necessarily valid.

The program must be compiled using the XMLPARSE(XMLSS) compiler option.

The example uses the schema that was described in the related concept about XML schemas.

Assume that file `item.xsd` contains the schema in text format, and that the preprocessed schema was generated in file `item.osr` by means of the following z/OS UNIX command:

```
xsdosrg -v -o /u/HLQ/xml/item.osr /u/HLQ/xml/item.xsd
```

The example uses the XML-SCHEMA clause to associate the XML schema name `schema` with the ddname `ddschema`. The following DD statement associates the ddname with the external z/OS UNIX file that contains the schema:

```
//GO.DDSHEMA DD PATH='/u/HLQ/xml/item.osr'
```

Program ValidCk

Identification division.

Program-id. ValidCk.

Environment division.

Configuration section.

Special-names.

xml-schema schema is 'ddschema'.

Data division.

Working-storage section.

1 xml-decode.

2 rtn comp Pic 9(2).

2 rsn comp-5 Pic 9(4).

1 hv pic x(16) value '0123456789ABCDEF'.

1 T Pic 999 COMP.

1 xml-document-1.

2 pic x(52) value

'<!--Valid: the "itemName" element can be omitted-->'.

2 pic x(31) value '<stockItem itemNumber="123-AB">'.

2 pic x(36) value ' <quantityOnHand>1</quantityOnHand>'.

2 pic x(12) value '</stockItem>'.

1 xml-document-2.

2 pic x(44)

value '<!--Invalid: missing attribute itemNumber-->'.

2 pic x(11) value '<stockItem>'.

2 pic x(30) value ' <itemName>No name</itemName>'.

2 pic x(36) value ' <quantityOnHand>1</quantityOnHand>'.

2 pic x(12) value '</stockItem>'.

```

1 xml-document-3.
2 pic x(47)
  value '<!--Invalid: unexpected attribute warehouse-->'.
2 pic x(46) value
  '<stockItem itemNumber="074-UN" warehouse="NJ">'.
2 pic x(37) value ' <quantityOnHand>10</quantityOnHand>'.
2 pic x(32) value ' <itemName>Not here!</itemName>'.
2 pic x(12) value '</stockItem>'.
1 xml-document-4.
2 pic x(46)
  value '<!--Invalid: illegal attribute value 123-Ab-->'.
2 pic x(31) value '<stockItem itemNumber="123-Ab">'.
2 pic x(33) value ' <itemName>Paintbrush</itemName>'.
2 pic x(37) value ' <quantityOnHand>10</quantityOnHand>'.
2 pic x(12) value '</stockItem>'.
1 xml-document-5.
2 pic x(46)
  value '<!--Invalid: missing element quantityOnHand-->'.
2 pic x(31) value '<stockItem itemNumber="074-UN">'.
2 pic x(32) value ' <itemName>Not here!</itemName>'.
2 pic x(12) value '</stockItem>'.
1 xml-document-6.
2 pic x(42)
  value '<!--Invalid: unexpected element comment-->'.
2 pic x(31) value '<stockItem itemNumber="123-AB">'.
2 pic x(33) value ' <itemName>Paintbrush</itemName>'.
2 pic x(36) value ' <quantityOnHand>1</quantityOnHand>'.
2 pic x(35) value ' <comment>Nylon bristles</comment>'.
2 pic x(12) value '</stockItem>'.
1 xml-document-7.
2 pic x(46) value
  '<!--Invalid: out-of-range element value 100-->'.
2 pic x(31) value '<stockItem itemNumber="123-AB">'.
2 pic x(33) value ' <itemName>Paintbrush</itemName>'.
2 pic x(38) value ' <quantityOnHand>100</quantityOnHand>'.
2 pic x(12) value '</stockItem>'.
Procedure division.
m.
  xml parse xml-document-1 validating with file schema
  processing procedure p
  xml parse xml-document-2 validating with file schema
  processing procedure p
  xml parse xml-document-3 validating with file schema
  processing procedure p
  xml parse xml-document-4 validating with file schema
  processing procedure p
  xml parse xml-document-5 validating with file schema
  processing procedure p
  xml parse xml-document-6 validating with file schema
  processing procedure p
  xml parse xml-document-7 validating with file schema
  processing procedure p
  goback
  .
p.
  evaluate xml-event
  when 'COMMENT'
    display ' '
    display xml-text
  when 'END-OF-DOCUMENT'
    display ' Document successfully parsed.'
  when 'EXCEPTION'
    move xml-code to xml-decode
    Divide rsn by 16 giving tally remainder T
    display ' RC=' rtn ', reason=x'''
      hv(function mod(rsn / 4096 16) + 1:1)
      hv(function mod(rsn / 256 16) + 1:1)

```

```

                hv(function mod(rsn / 16 16) + 1:1)
                hv(T + 1:1) ''''
            end-evaluate
        .
End program ValidCk.

```

Output from program ValidCk

In the following output, you can see which XML documents in the source program failed validation against the schema.

For those documents that were not valid, the parser signaled an XML exception and passed control to the processing procedure with special register XML-EVENT containing 'EXCEPTION' and special-register XML-CODE containing the return code and a specific reason code.

Valid: the "itemName" element can be omitted
Document successfully parsed.

Invalid: missing attribute itemNumber
RC=24, reason=x'8613'

Invalid: unexpected attribute warehouse
RC=24, reason=x'8612'

Invalid: illegal attribute value 123-Ab
RC=24, reason=x'8809'

Invalid: missing element quantityOnHand
RC=24, reason=x'8611'

Invalid: unexpected element comment
RC=24, reason=x'8607'

Invalid: out-of-range element value 100
RC=24, reason=x'8803'

RELATED CONCEPTS

"XML-CODE" on page 535

"XML schemas" on page 542

RELATED TASKS

"Parsing XML documents with validation" on page 540

"Handling XML PARSE exceptions" on page 552

RELATED REFERENCES

"XML PARSE exceptions with XMLPARSE(XMLSS) in effect" on page 701

Chapter 29. Producing XML output

You can produce XML output from a COBOL program by using the XML GENERATE statement.

In the XML GENERATE statement, you identify the source and the output data items. You can optionally also identify:

- A field to receive a count of the XML characters generated
- A code page in which the generated XML document is to be encoded
- A *namespace* for the generated document
- A namespace prefix to qualify the start and end tag of each element, if you specify a namespace
- A user-defined element or attribute name in the generated XML document
- Attributes or elements to be suppressed according to some specified conditions
- Particular items to be specified as attributes, elements or content in the generated XML output.
- A statement to receive control if an exception occurs

Optionally, you can generate an XML declaration for the document, and can cause eligible source data items to be expressed as attributes in the output rather than as elements.

You can use the XML-CODE special register to determine the status of XML generation.

After you transform COBOL data items to XML, you can use the resulting XML output in various ways, such as deploying it in a web service, passing it as a message to WebSphere MQ, or transmitting it for subsequent conversion to a CICS communication area.

Link-edit considerations: COBOL programs that contain the XML GENERATE statement must be link-edited with AMODE 31.

RELATED TASKS

“Generating XML output”

“Controlling the encoding of generated XML output” on page 576

“Handling XML GENERATE exceptions” on page 577

“Enhancing XML output” on page 583

RELATED REFERENCES

Extensible Markup Language (XML)

XML GENERATE statement (*Enterprise COBOL Language Reference*)

Generating XML output

To transform COBOL data to XML, use the XML GENERATE statement as in the example below.

```
XML GENERATE XML-OUTPUT FROM SOURCE-REC
COUNT IN XML-CHAR-COUNT
ON EXCEPTION
DISPLAY 'XML generation error ' XML-CODE
```

```

        STOP RUN
        NOT ON EXCEPTION
        DISPLAY 'XML document was successfully generated.'
END-XML

```

In the XML GENERATE statement, you first identify the data item (XML-OUTPUT in the example above) that is to receive the XML output. Define the data item to be large enough to contain the generated XML output, typically five to 10 times the size of the COBOL source data depending on the length of its data-name or data-names.

In the DATA DIVISION, you can define the receiving identifier as alphanumeric (either an alphanumeric group item or an elementary item of category alphanumeric) or as national (either a national group item or an elementary item of category national).

Next you identify the source data item that is to be transformed to XML format (SOURCE-REC in the example). The source data item can be an alphanumeric group item, national group item, or elementary data item of class alphanumeric or national.

Some COBOL data items are not transformed to XML, but are ignored. Subordinate data items of an alphanumeric group item or national group item that you transform to XML are ignored if they:

- Specify the REDEFINES clause, or are subordinate to such a redefining item
- Specify the RENAMES clause

These items in the source data item are also ignored when you generate XML:

- Elementary FILLER (or unnamed) data items
- Slack bytes inserted for SYNCHRONIZED data items

No extra white space (for example, new lines or indentation) is inserted to make the generated XML more readable.

Optionally, you can code the COUNT IN phrase to obtain the number of XML character encoding units that are filled during generation of the XML output. If the receiving identifier has category national, the count is in UTF-16 character encoding units. For all other encodings (including UTF-8), the count is in bytes.

You can use the count field as a reference modification length to obtain only that portion of the receiving data item that contains the generated XML output. For example, XML-OUTPUT(1:XML-CHAR-COUNT) references the first XML-CHAR-COUNT character positions of XML-OUTPUT.

Consider the following program excerpt:

```

01 doc pic x(512).
01 docSize pic 9(9) binary.
01 G.
   05 A pic x(3) value "aaa".
   05 B.
      10 C pic x(3) value "ccc".
      10 D pic x(3) value "ddd".
   05 E pic x(3) value "eee".
   . . .
XML Generate Doc from G

```

The code above generates the following XML document, in which A, B, and E are expressed as child elements of element G, and C and D become child elements of element B:

```
<G><A>aaa</A><B><C>ccc</C><D>ddd</D></B><E>eee</E></G>
```

Alternatively, you can specify the ATTRIBUTES phrase of the XML GENERATE statement. The ATTRIBUTES phrase causes every eligible data item included in the generated XML document to be expressed as an attribute of the containing XML element, rather than as a child element of the containing XML element. To be eligible, the data item must be elementary, must have a name other than FILLER, and must not have an OCCURS clause in its data description entry. The containing XML element corresponds to the group data item that is immediately superordinate to the elementary data item. Optionally, you can specify more precise control of which data items should be expressed as attributes or elements by using the TYPE OF phrase.

For example, suppose that the XML GENERATE statement in the program excerpt above had instead been coded as follows:

```
XML Generate Doc from G with attributes
```

The code would then generate the following XML document, in which A and E are expressed as attributes of element G, and C and D become attributes of element B:

```
<G A="aaa" E="eee"><B C="ccc" D="ddd"></B></G>
```

Optionally, you can code the ENCODING phrase of the XML GENERATE statement to specify the CCSID of the generated XML document. If you do not use the ENCODING phrase, the document encoding is determined by the category of the receiving data item and by the CODEPAGE compiler option. For further details, see the related task below about controlling the encoding of generated XML output.

Optionally, you can code the XML-DECLARATION phrase to cause the generated XML document to have an XML declaration that includes version information and an encoding declaration. If the receiving data item is of category:

- National: The encoding declaration has the value UTF-16 (encoding="UTF-16").
- Alphanumeric: The encoding declaration is derived from the ENCODING phrase, if specified, or from the CODEPAGE compiler option in effect for the program if the ENCODING phrase is not specified.

For example, the program excerpt below specifies the XML-DECLARATION phrase of XML GENERATE, and specifies encoding with CCSID 1208 (UTF-8):

```
01 Greeting.  
   05 msg pic x(80) value 'Hello, world!'.  
   . . .  
   XML Generate Doc from Greeting  
     with Encoding 1208  
     with XML-declaration  
   End-XML
```

The code above generates the following XML document:

```
<?xml version="1.0" encoding="UTF-8"?><Greeting><msg>Hello, world!</msg></Greeting>
```

If you do not code the XML-DECLARATION phrase, an XML declaration is not generated.

Optionally, you can code the NAMESPACE phrase to specify a *namespace* for the generated XML document. The namespace value must be a valid *Uniform Resource*

Identifier (URI), for example, a URL (Uniform Resource Locator); for further details, see the related concept about URI syntax below.

Specify the namespace in an identifier or literal of either category national or alphanumeric.

If you specify a namespace, but do not specify a namespace prefix (described below), the namespace becomes the *default namespace* for the document. That is, the namespace define on the root element applies by default to each element name in the document, including the root element.

For example, consider the following data definitions and XML GENERATE statement:

```
01 Greeting.  
    05 msg pic x(80) value 'Hello, world!'.  
01 NS pic x(20) value 'http://example'.  
    . . .  
    XML Generate Doc from Greeting  
    namespace is NS
```

The resulting XML document has a default namespace (`http://example`), as follows:

```
<Greeting xmlns="http://example"><msg>Hello, world!</msg></Greeting>
```

If you do not specify a namespace, the element names in the generated XML document are not in any namespace.

Optionally, you can code the NAMESPACE-PREFIX phrase to specify a prefix to be applied to the start and end tag of each element in the generated document. You can specify a prefix only if you have specified a namespace as described above.

When the XML GENERATE statement is executed, the prefix value must be a valid XML name, but without the colon (:); see the related reference below about namespaces for details. The value can have trailing spaces, which are removed before the prefix is used.

Specify the namespace prefix in an identifier or literal of either category national or alphanumeric.

It is recommended that the prefix be short, because it qualifies the start and end tag of each element.

For example, consider the following data definitions and XML GENERATE statement:

```
01 Greeting.  
    05 msg pic x(80) value 'Hello, world!'.  
01 NS pic x(20) value 'http://example'.  
01 NP pic x(5) value 'pre'.  
    . . .  
    XML Generate Doc from Greeting  
    namespace is NS  
    namespace-prefix is NP
```

The resulting XML document has an explicit namespace (`http://example`), and the prefix `pre` is applied to the start and end tag of the elements `Greeting` and `msg`, as follows:

```
<pre:Greeting xmlns:pre="http://example"><pre:msg>Hello, world!</pre:msg></pre:Greeting>
```

Optionally, you can code the NAME phrase to specify attribute and element names in the generated XML document. The attribute and element names must be alphanumeric or national literals and must be legal names according to the XML 1.0 standard.

For example, consider the following data structure and XML GENERATE statement:

```
01 Msg.
  02 Msg-Severity pic 9 value 1.
  02 Msg-Date pic 9999/99/99 value "2012/04/12".
  02 Msg-Text pic X(50) value "Sell everything!".
01 Doc pic X(500).
  XML Generate Doc from Msg
  With attributes
  Name of Msg      is "Message"
  Msg-Severity     is "Severity"
  Msg-Date        is "Date"
  Msg-Text        is "Text"
End-XML
```

The resulting XML document is as follows:

```
<Message Severity="1" Date="2012/04/12" Text="Sell everything!"></Message>
```

Optionally, you can code the SUPPRESS phrase to specify whether individual data items are generated based on whether or not they meet certain criteria.

For example, consider the following data structure and XML GENERATE statement to suppress spaces and zeros:

```
01 G.
  02 SensitiveInfo.
    03 SSN pic x(11) value '123-45-6789'.
    03 HomeAddress pic x(50) value '123 Main St, Anytown, USA'.
  02 Aarray value spaces.
    03 A pic AAA occurs 5.
  02 Barray value spaces.
    03 B pic XXX occurs 5.
  02 Carray value zeros.
    03 C pic 999 occurs 5.
  Move 'abc' to A(1)
  Move 123 to C(3)
  XML Generate Doc from G
  Suppress SensitiveInfo
    every nonnumeric element when space
    every numeric element when zero
End-XML
```

The resulting XML document is as follows:

```
<G>
  <Aarray><A>abc</A></Aarray>
  <Carray><C>123</C></Carray>
</G>
```

Optionally, you can use the TYPE OF phrase to specify whether individual data items are expressed as attributes, elements or content.

For example, consider the following data structure and XML GENERATE statement:

```
01 Msg.
  02 Msg-Severity pic 9 value 1.
  02 Msg-Date pic 9999/99/99 value "2012/04/12".
  02 Msg-Text pic X(50) value "Sell everything!".
01 Doc pic X(500).
  XML Generate Doc from Msg
  With attributes
```

Type of Msg-Severity is attribute
Msg-Date is attribute
Msg-Text is element
End-XML

The resulting XML document is as follows:

```
<Msg Msg-Severity="1" Msg-Date="2012/04/12">  
  <Msg-Text>Sell everything!</Msg-Text></Msg>
```

In addition, you can specify either or both of the following phrases to receive control after generation of the XML document:

- ON EXCEPTION, to receive control if an error occurs during XML generation
- NOT ON EXCEPTION, to receive control if no error occurs

You can end the XML GENERATE statement with the explicit scope terminator END-XML. Code END-XML to nest an XML GENERATE statement that has the ON EXCEPTION or NOT ON EXCEPTION phrase in a conditional statement.

XML generation continues until either the COBOL source record has been transformed to XML or an error occurs. If an error occurs, the results are as follows:

- The XML-CODE special register contains a nonzero exception code.
- Control is passed to the ON EXCEPTION phrase, if specified, otherwise to the end of the XML GENERATE statement.

If no error occurs during XML generation, the XML-CODE special register contains zero, and control is passed to the NOT ON EXCEPTION phrase if specified or to the end of the XML GENERATE statement otherwise.

“Example: generating XML” on page 578

RELATED CONCEPTS

Uniform Resource Identifier (URI): Generic Syntax

RELATED TASKS

“Controlling the encoding of generated XML output”

“Handling XML GENERATE exceptions” on page 577

“Processing UTF-8 data” on page 141

RELATED REFERENCES

XML GENERATE statement (*Enterprise COBOL Language Reference*)

Extensible Markup Language (XML)

Namespaces in XML 1.0

Controlling the encoding of generated XML output

When you generate XML output by using the XML GENERATE statement, you can control the encoding of the output by the category of the data item that receives the output, and by identifying the code page using the WITH ENCODING phrase of the XML GENERATE statement.

If you specify the WITH ENCODING *codepage* phrase to designate the coded character set identifier (CCSID) of the output document, *codepage* must specify an unsigned integer data item or unsigned integer literal that identifies one of the code pages supported for COBOL XML processing as described in the related reference below about the encoding of XML documents:

- If the data item that receives the generated XML is of category national, the WITH ENCODING phrase must specify 1200, the CCSID for Unicode UTF-16.
- If the receiving identifier is of category alphanumeric, the WITH ENCODING phrase must specify CCSID 1208 or the CCSID of a supported EBCDIC code page.

If you do not code the WITH ENCODING phrase, the generated XML output is encoded as shown in the table below.

Table 74. Encoding of generated XML if the ENCODING phrase is omitted

If you define the receiving XML identifier as:	The generated XML output is encoded in:
Alphanumeric	The code page specified by the CODEPAGE compiler option in effect when the source was compiled
National	UTF-16 big-endian (UTF-16BE, CCSID 1200)

A byte order mark is not generated.

For details about how data items are converted to XML and how the XML element names and attributes names are formed from the COBOL data-names, see the related reference below about the operation of the XML GENERATE statement.

RELATED REFERENCES

“CODEPAGE” on page 313

“The encoding of XML documents” on page 546

XML GENERATE statement (*Enterprise COBOL Language Reference*)

Operation of XML GENERATE (*Enterprise COBOL Language Reference*)

Handling XML GENERATE exceptions

When an error is detected during generation of XML output, an exception condition exists. You can write code to check the XML-CODE special register, which contains a numeric exception code that indicates the error type.

To handle errors, use either or both of the following phrases of the XML GENERATE statement:

- ON EXCEPTION
- COUNT IN

If you code the ON EXCEPTION phrase in the XML GENERATE statement, control is transferred to the imperative statement that you specify. You might code an imperative statement, for example, to display the XML-CODE value. If you do not code an ON EXCEPTION phrase, control is transferred to the end of the XML GENERATE statement.

When an error occurs, one problem might be that the data item that receives the XML output is not large enough. In that case, the XML output is not complete, and the XML-CODE special register contains error code 400.

You can examine the generated XML output by doing these steps:

1. Code the COUNT IN phrase in the XML GENERATE statement.

The count field that you specify holds a count of the XML character encoding units that are filled during XML generation. If you define the XML output as

national, the count is in UTF-16 character encoding units; for all other encodings (including for UTF-8), the count is in bytes.

2. Use the count field as a reference modification length to refer to the substring of the receiving data item that contains the XML characters that were generated until the point when the error occurred.

For example, if XML-OUTPUT is the data item that receives the XML output, and XML-CHAR-COUNT is the count field, then XML-OUTPUT(1:XML-CHAR-COUNT) references the XML output.

Use the contents of XML-CODE to determine what corrective action to take. For a list of the exceptions that can occur during XML generation, see the related reference below.

RELATED TASKS

“Referring to substrings of data items” on page 111

RELATED REFERENCES

“XML GENERATE exceptions” on page 710

XML-CODE (*Enterprise COBOL Language Reference*)

Example: generating XML

The following example simulates the building of a purchase order in a group data item, and generates an XML version of that purchase order.

Program XGFX uses XML GENERATE to produce XML output in elementary data item xmlP0 from the source record, group data item purchaseOrder. Elementary data items in the source record are converted to character format as necessary, and the characters are inserted as the values of XML attributes whose names are derived from the data-names in the source record.

XGFX calls program Pretty, which uses the XML PARSE statement with processing procedure p to format the XML output with new lines and indentation so that the XML content can more easily be verified.

Program XGFX

```
Identification division.
  Program-id. XGFX.
Data division.
  Working-storage section.
    01 numItems pic 99 global.
    01 purchaseOrder global.
      05 orderDate pic x(10).
      05 shipTo.
        10 country pic xx value 'US'.
        10 name pic x(30).
        10 street pic x(30).
        10 city pic x(30).
        10 state pic xx.
        10 zip pic x(10).
      05 billTo.
        10 country pic xx value 'US'.
        10 name pic x(30).
        10 street pic x(30).
        10 city pic x(30).
        10 state pic xx.
        10 zip pic x(10).
      05 orderComment pic x(80).
      05 items occurs 0 to 20 times depending on numItems.
```

```

    10 item.
        15 partNum pic x(6).
        15 productName pic x(50).
        15 quantity pic 99.
        15 USPrice pic 999v99.
        15 shipDate pic x(10).
        15 itemComment pic x(40).
    01 numChars comp pic 999.
    01 xmlPO pic x(999).
Procedure division.
m.
    Move 20 to numItems
    Move spaces to purchaseOrder

    Move '1999-10-20' to orderDate

    Move 'US' to country of shipTo
    Move 'Alice Smith' to name of shipTo
    Move '123 Maple Street' to street of shipTo
    Move 'Mill Valley' to city of shipTo
    Move 'CA' to state of shipTo
    Move '90952' to zip of shipTo

    Move 'US' to country of billTo
    Move 'Robert Smith' to name of billTo
    Move '8 Oak Avenue' to street of billTo
    Move 'Old Town' to city of billTo
    Move 'PA' to state of billTo
    Move '95819' to zip of billTo
    Move 'Hurry, my lawn is going wild!' to orderComment

    Move 0 to numItems
    Call 'addFirstItem'
    Call 'addSecondItem'
    Move space to xmlPO
    Xml generate xmlPO from purchaseOrder count in numChars
        with xml-declaration with attributes
            namespace 'http://www.example.com' namespace-prefix 'po'
    Call 'pretty' using xmlPO value numChars
    Goback
    .

Identification division.
    Program-id. 'addFirstItem'.
Procedure division.
    Add 1 to numItems
    Move '872-AA' to partNum(numItems)
    Move 'Lawnmower' to productName(numItems)
    Move 1 to quantity(numItems)
    Move 148.95 to USPrice(numItems)
    Move 'Confirm this is electric' to itemComment(numItems)
    Goback.
End program 'addFirstItem'.

Identification division.
    Program-id. 'addSecondItem'.
Procedure division.
    Add 1 to numItems
    Move '926-AA' to partNum(numItems)
    Move 'Baby Monitor' to productName(numItems)
    Move 1 to quantity(numItems)
    Move 39.98 to USPrice(numItems)
    Move '1999-05-21' to shipDate(numItems)
    Goback.
End program 'addSecondItem'.

End program XGFX.

```

Program Pretty

```
Process xmlparse(xmlss), codepage(37)
Identification division.
  Program-id. Pretty.
Data division.
Working-storage section.
  01 prettyPrint.
    05 pose pic 999.
    05 posd pic 999.
    05 depth pic 99.
    05 inx pic 999.
    05 elementName pic x(30).
    05 indent pic x(40).
    05 buffer pic x(998).
    05 lastitem pic 9.
      88 unknown value 0.
      88 xml-declaration value 1.
      88 element value 2.
      88 attribute value 3.
      88 charcontent value 4.
Linkage section.
  1 doc.
  2 pic x occurs 16384 times depending on len.
  1 len comp-5 pic 9(9).
Procedure division using doc value len.
  m.
    Move space to prettyPrint
    Move 0 to depth
    Move 1 to posd pose
    Xml parse doc processing procedure p
    Goback
  .
  p.
    Evaluate xml-event
      When 'VERSION-INFORMATION'
        String '<?xml version="' xml-text '"' delimited by size
          into buffer with pointer posd
        Set xml-declaration to true
      When 'ENCODING-DECLARATION'
        String ' encoding="' xml-text '"' delimited by size
          into buffer with pointer posd
      When 'STANDALONE-DECLARATION'
        String ' standalone="' xml-text '"' delimited by size
          into buffer with pointer posd
      When 'START-OF-ELEMENT'
        Evaluate true
          When xml-declaration
            String '?>' delimited by size into buffer
              with pointer posd
            Set unknown to true
            Perform printline
            Move 1 to posd
          When element
            String '>' delimited by size into buffer
              with pointer posd
          When attribute
            String '>' delimited by size into buffer
              with pointer posd
        End-evaluate
        If elementName not = space
          Perform printline
        End-if
        Move xml-text to elementName
        Add 1 to depth
        Move 1 to pose
        Set element to true
```

```

If xml-namespace-prefix = space
  String '<' xml-text delimited by size
    into buffer with pointer pose
Else
  String '<' xml-namespace-prefix ':' xml-text
    delimited by size into buffer with pointer pose
End-if
Move pose to posd
When 'ATTRIBUTE-NAME'
If element
  String ' ' delimited by size into buffer
    with pointer posd
Else
  String '"' delimited by size into buffer
    with pointer posd
End-if
If xml-namespace-prefix = space
  String xml-text '=' delimited by size into buffer
    with pointer posd
Else
  String xml-namespace-prefix ':' xml-text '='
    delimited by size into buffer with pointer posd
End-if
Set attribute to true
When 'NAMESPACE-DECLARATION'
If element
  String ' ' delimited by size into buffer
    with pointer posd
Else
  String '"' delimited by size into buffer
    with pointer posd
End-if
If xml-namespace-prefix = space
  String 'xmlns=' xml-namespace delimited by size
    into buffer with pointer posd
Else
  String 'xmlns:' xml-namespace-prefix '=' xml-namespace
    delimited by size into buffer with pointer posd
End-if
Set attribute to true
When 'ATTRIBUTE-CHARACTERS'
String xml-text delimited by size into buffer
  with pointer posd
When 'ATTRIBUTE-CHARACTER'
String xml-text delimited by size into buffer
  with pointer posd
When 'CONTENT-CHARACTERS'
Evaluate true
  When element
    String '>' delimited by size into buffer
      with pointer posd
  When attribute
    String '>' delimited by size into buffer
      with pointer posd
End-evaluate
String xml-text delimited by size into buffer
  with pointer posd
Set charcontent to true
When 'CONTENT-CHARACTER'
Evaluate true
  When element
    String '>' delimited by size into buffer
      with pointer posd
  When attribute
    String '>' delimited by size into buffer
      with pointer posd
End-evaluate

```

```

String xml-text delimited by size into buffer
  with pointer posd
Set charcontent to true
When 'END-OF-ELEMENT'
Move space to elementName
Evaluate true
  When element
    String '/>' delimited by size into buffer
    with pointer posd
  When attribute
    String '">' delimited by size into buffer
    with pointer posd
  When other
    If xml-namespace-prefix = space
      String '</' xml-text '>' delimited by size
      into buffer with pointer posd
    Else
      String '</' xml-namespace-prefix ':' xml-text '>'
      delimited by size into buffer with pointer posd
    End-if
  End-evaluate
Set unknown to true
Perform printline
Subtract 1 from depth
Move 1 to posd
When other
Continue
End-evaluate
.
printline.
Compute inx = function max(0 2 * depth - 2) + posd - 1
If inx > 120
  compute inx = 117 - function max(0 2 * depth - 2)
  If depth > 1
    Display indent(1:2 * depth - 2) buffer(1:inx) '...'
  Else
    Display buffer(1:inx) '...'
  End-if
Else
  If depth > 1
    Display indent(1:2 * depth - 2) buffer(1:posd - 1)
  Else
    Display buffer(1:posd - 1)
  End-if
End-if
.
End program Pretty.

```

Output from program XGFX

```

<?xml version="1.0" encoding="IBM-037"?>
<po:purchaseOrder xmlns:po="http://www.example.com" orderDate="1999-10-20" orderComment="Hurry, my lawn is going wild!">
  <po:shipTo country="US" name="Alice Smith" street="123 Maple Street" city="Mill Valley" state="CA" zip="90952"/>
  <po:billTo country="US" name="Robert Smith" street="8 Oak Avenue" city="Old Town" state="PA" zip="95819"/>
  <po:items>
    <po:item partNum="872-AA" productName="Lawnmower" quantity="1" USPrice="148.95" shipDate=" " itemComment="Confirm...">
  </po:items>
  <po:items>
    <po:item partNum="926-AA" productName="Baby Monitor" quantity="1" USPrice="39.98" shipDate="1999-05-21" itemComme...>
  </po:items>
</po:purchaseOrder>

```

RELATED TASKS

Chapter 28, "Processing XML input," on page 527

RELATED REFERENCES

“XMLPARSE” on page 373 (compiler option)
Operation of XML GENERATE (*Enterprise COBOL Language Reference*)

Enhancing XML output

It might happen that the information that you want to express in XML format already exists in a group item in the DATA DIVISION, but you are unable to use that item directly to generate an XML document because of one or more factors.

For example:

- In addition to the required data, the item has subordinate data items that contain values that are irrelevant to the XML output document.
- The names of the required data items are unsuitable for external presentation, and are possibly meaningful only to programmers.
- The required data items are broken up into too many components, and should be output as the content of the containing group.

There are various ways that you can deal with such situations. One possible technique is to define a new data item that has the appropriate characteristics, and move the required data to the appropriate fields of this new data item. However, this approach is somewhat laborious and requires careful maintenance to keep the original and new data items synchronized.

A superior approach that addresses most such problems is to use the new optional phrases of the XML GENERATE statement in order to:

- Provide more meaningful and appropriate names for the selected elementary items and for the group items that contain them.
- Exclude irrelevant data items from the generated XML by suppressing them based on their values.

The example that is referenced below shows a way to do so.

“Example: enhancing XML output”

RELATED REFERENCES

Operation of XML GENERATE (*Enterprise COBOL Language Reference*)

Example: enhancing XML output

The following example shows how you can modify XML output.

Consider the following data structure. The XML that is generated from the structure suffers from several problems that can be corrected.

```
01 CDR-LIFE-BASE-VALUES-BOX.  
   15 CDR-LIFE-BASE-VAL-DATE    PIC X(08).  
   15 CDR-LIFE-BASE-VALUE-LINE OCCURS 2 TIMES.  
     20 CDR-LIFE-BASE-DESC.  
       25 CDR-LIFE-BASE-DESC1 PIC X(15).  
       25 FILLER                PIC X(01).  
       25 CDR-LIFE-BASE-LIT    PIC X(08).  
       25 CDR-LIFE-BASE-DTE    PIC X(08).  
     20 CDR-LIFE-BASE-PRICE.  
       25 CDR-LIFE-BP-SPACE    PIC 9(08).  
       25 CDR-LIFE-BP-DASH     PIC X.  
       25 CDR-LIFE-BP-SPACE1   PIC X(02).  
     20 CDR-LIFE-BASE-PRICE-ED REDEFINES
```

```

        CDR-LIFE-BASE-PRICE  PIC $$$.$$
20  CDR-LIFE-BASE-QTY.
        25  CDR-LIFE-QTY-SPACE  PIC X(08).
        25  CDR-LIFE-QTY-DASH    PIC X.
        25  CDR-LIFE-QTY-SPACE1 PIC X(03).
        25  FILLER                PIC X(02).
20  CDR-LIFE-BASE-VALUE  PIC $$$9.99
        BLANK WHEN ZERO.
15  CDR-LIFE-BASE-TOT-VALUE  PIC X(15)

```

When this data structure is populated with some sample values, and XML is generated directly from it and then formatted using program Pretty (shown in "Example: generating XML" on page 578), the result is as follows:

```

<CDR-LIFE-BASE-VALUES-BOX>
  <CDR-LIFE-BASE-VAL-DATE>01/02/03</CDR-LIFE-BASE-VAL-DATE>
  <CDR-LIFE-BASE-VALUE-LINE>
    <CDR-LIFE-BASE-DESC>
      <CDR-LIFE-BASE-DESC1>First</CDR-LIFE-BASE-DESC1>
      <CDR-LIFE-BASE-LIT> </CDR-LIFE-BASE-LIT>
      <CDR-LIFE-BASE-DTE>01/01/01</CDR-LIFE-BASE-DTE>
    </CDR-LIFE-BASE-DESC>
    <CDR-LIFE-BASE-PRICE>
      <CDR-LIFE-BP-SPACE>23</CDR-LIFE-BP-SPACE>
      <CDR-LIFE-BP-DASH>.</CDR-LIFE-BP-DASH>
      <CDR-LIFE-BP-SPACE1>00</CDR-LIFE-BP-SPACE1>
    </CDR-LIFE-BASE-PRICE>
    <CDR-LIFE-BASE-QTY>
      <CDR-LIFE-QTY-SPACE>123</CDR-LIFE-QTY-SPACE>
      <CDR-LIFE-QTY-DASH>.</CDR-LIFE-QTY-DASH>
      <CDR-LIFE-QTY-SPACE1>000</CDR-LIFE-QTY-SPACE1>
    </CDR-LIFE-BASE-QTY>
    <CDR-LIFE-BASE-VALUE>$765.00</CDR-LIFE-BASE-VALUE>
  </CDR-LIFE-BASE-VALUE-LINE>
  <CDR-LIFE-BASE-VALUE-LINE>
    <CDR-LIFE-BASE-DESC>
      <CDR-LIFE-BASE-DESC1>Second</CDR-LIFE-BASE-DESC1>
      <CDR-LIFE-BASE-LIT> </CDR-LIFE-BASE-LIT>
      <CDR-LIFE-BASE-DTE>02/02/02</CDR-LIFE-BASE-DTE>
    </CDR-LIFE-BASE-DESC>
    <CDR-LIFE-BASE-PRICE>
      <CDR-LIFE-BP-SPACE>34</CDR-LIFE-BP-SPACE>
      <CDR-LIFE-BP-DASH>.</CDR-LIFE-BP-DASH>
      <CDR-LIFE-BP-SPACE1>00</CDR-LIFE-BP-SPACE1>
    </CDR-LIFE-BASE-PRICE>
    <CDR-LIFE-BASE-QTY>
      <CDR-LIFE-QTY-SPACE>234</CDR-LIFE-QTY-SPACE>
      <CDR-LIFE-QTY-DASH>.</CDR-LIFE-QTY-DASH>
      <CDR-LIFE-QTY-SPACE1>000</CDR-LIFE-QTY-SPACE1>
    </CDR-LIFE-BASE-QTY>
    <CDR-LIFE-BASE-VALUE>$654.00</CDR-LIFE-BASE-VALUE>
  </CDR-LIFE-BASE-VALUE-LINE>
  <CDR-LIFE-BASE-TOT-VALUE>Very high!</CDR-LIFE-BASE-TOT-VALUE>
</CDR-LIFE-BASE-VALUES-BOX>

```

This generated XML suffers from several problems:

- The element names are long and not very meaningful. There may also be an XML schema that specifies required tag names.
- The XML schema may require some tag names that are COBOL reserved words such as DATE/TIME
- Some fields that are elements should be attributes such as, CDR-LIFE-BASE-VAL-DATE and CDR-LIFE-BASE-DESC1.
- There is unwanted data, for example, CDR-LIFE-BASE-LIT and CDR-LIFE-BASE-DTE.

- Other required fields are split into too many subcomponents. For example, CDR-LIFE-BASE-PRICE has three subcomponents for one amount.

These and other characteristics of the XML output can be remedied by using additional phrases of the XML GENERATE statement as follows:

- Use the NAME OF phrase to provide appropriate tag or attribute names.
- Use the TYPE OF ... IS ATTRIBUTE phrase to select the fields which should be XML attributes rather than elements.
- Use the TYPE OF ... IS CONTENT phrase to suppress tags for excessive subcomponents.
- Use the SUPPRESS ... WHEN phrase to exclude fields that contain uninteresting values.

Here is an example of the XML GENERATE statement to address those problems:

```
XML generate Doc from CDR-LIFE-BASE-VALUES-BOX
Count in tally
Name of
    CDR-LIFE-BASE-VALUES-BOX
is 'Base_Values'
    CDR-LIFE-BASE-VAL-DATE
is 'Date'
    CDR-LIFE-BASE-DTE
is 'Date'
    CDR-LIFE-BASE-VALUE-LINE
is 'BaseValueLine'
    CDR-LIFE-BASE-DESC1
is 'Description'
    CDR-LIFE-BASE-PRICE
is 'BasePrice'
    CDR-LIFE-BASE-QTY
is 'BaseQuantity'
    CDR-LIFE-BASE-VALUE
is 'BaseValue'
    CDR-LIFE-BASE-TOT-VALUE
is 'TotalValue'
Type of
    CDR-LIFE-BASE-VAL-DATE is attribute
    CDR-LIFE-BASE-DESC1 is attribute
    CDR-LIFE-BP-SPACE is content
    CDR-LIFE-BP-DASH is content
    CDR-LIFE-BP-SPACE1 is content
    CDR-LIFE-QTY-SPACE is content
    CDR-LIFE-QTY-DASH is content
    CDR-LIFE-QTY-SPACE1 is content
Suppress every nonnumeric when space
every numeric when zero
```

The result of generating and formatting XML from the statement shown above is more usable:

```
<Base_Values Date="01/02/03">
  <BaseValueLine Description="First">
    <Date>01/01/01</Date>
    <BasePrice>23.00</BasePrice>
    <BaseQuantity>123.000</BaseQuantity>
    <BaseValue>$765.00</BaseValue>
  </BaseValueLine>
  <BaseValueLine Description="Second">
    <Date>02/02/02</Date>
    <BasePrice>34.00</BasePrice>
    <BaseQuantity>234.000</BaseQuantity>
```

```
<BaseValue>$654.00</BaseValue>
</BaseValueLine>
<TotalValue>Very high!</TotalValue>
</Base_Values>
```

Note that the COBOL reserved word DATE can now be used as an XML tag name in the output. Characters such as accented letters and period . that are illegal in single-byte data names can also be used.

RELATED REFERENCES

Operation of XML GENERATE (*Enterprise COBOL Language Reference*)
REPLACE statement (*Enterprise COBOL Language Reference*)

Part 6. Developing object-oriented programs

Chapter 30. Writing object-oriented programs

When you write an object-oriented (OO) program, you have to determine what classes you need and the methods and data that the classes need to do their work.

OO programs are based on *objects* (entities that encapsulate state and behavior) and their classes, methods, and data. A *class* is a template that defines the state and the capabilities of an object. Usually a program creates and works with multiple *object instances* (or simply, *instances*) of a class, that is, multiple objects that are members of that class. The state of each instance is stored in data known as *instance data*, and the capabilities of each instance are called *instance methods*. A class can define data that is shared by all instances of the class, known as *factory* or *static* data, and methods that are supported independently of any object instance, known as *factory* or *static* methods.

Using Enterprise COBOL, you can:

- Define classes, with methods and data implemented in COBOL.
- Create instances of Java and COBOL classes.
- Invoke methods on Java and COBOL objects.
- Write classes that inherit from Java classes or other COBOL classes.
- Define and invoke overloaded methods.

In Enterprise COBOL programs, you can call the services provided by the Java Native Interface (JNI) to obtain Java-oriented capabilities in addition to the basic OO capabilities available directly in the COBOL language.

In Enterprise COBOL classes, you can code CALL statements to interface with procedural COBOL programs. Thus COBOL class definition syntax can be especially useful for writing *wrapper* classes for procedural COBOL logic, enabling existing COBOL code to be accessed from Java.

Java code can create instances of COBOL classes, invoke methods of these classes, and can extend COBOL classes.

It is recommended that you develop and run OO COBOL programs and Java programs in the z/OS UNIX environment.

Restrictions:

- COBOL class definitions and methods cannot contain EXEC SQL statements and cannot be compiled using the SQL compiler option.
- COBOL class definitions and methods cannot contain EXEC SQLIMS statements and cannot be compiled using the SQLIMS compiler option.
- COBOL programs that use object-oriented syntax for Java interoperability cannot contain EXEC CICS statements, and cannot be run in CICS. They cannot be compiled using the CICS compiler option.

“Example: accounts” on page 590

RELATED TASKS

“Defining a class” on page 592

“Defining a class instance method” on page 597

"Defining a client" on page 606
"Defining a subclass" on page 617
"Defining a factory section" on page 621
Chapter 16, "Compiling, linking, and running OO applications," on page 291
Upgrading IBM COBOL source programs
(*Enterprise COBOL Migration Guide*)

RELATED REFERENCES
The Java Language Specification

Example: accounts

Consider the example of a bank in which customers can open accounts and make deposits to and withdrawals from their accounts. You could represent an account by a general-purpose class, called Account. Because there are many customers, multiple instances of the Account class could exist simultaneously.

After you determine the classes that you need, the next step is to determine the methods that the classes need to do their work. An Account class must provide the following services:

- Open the account.
- Get the current balance.
- Deposit to the account.
- Withdraw from the account.
- Report account status.

The following methods for an Account class meet those needs:

init Open an account and assign it an account number.

getBalance
Return the current balance of the account.

credit Deposit a given sum to the account.

debit Withdraw a given sum from the account.

print Display account number and account balance.

As you design an Account class and its methods, you discover the need for the class to keep some instance data. Typically, an Account object needs the following instance data:

- Account number
- Account balance
- Customer information: name, address, home phone, work phone, social security number, and so forth

To keep the example simple, however, it is assumed that the account number and account balance are the only instance data that the Account class needs.

Diagrams are helpful when you design classes and methods. The following diagram depicts a first attempt at a design of the Account class:

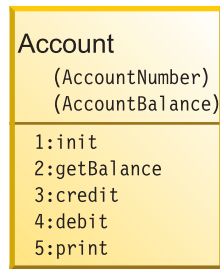

The words in parentheses in the diagrams are the names of the instance data, and the words that follow a number and colon are the names of the instance methods.

The structure below shows how the classes relate to each other, and is known as the *inheritance hierarchy*. The Account class inherits directly from the class `java.lang.Object`.

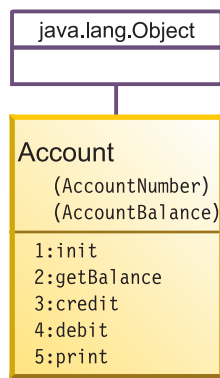

Subclasses

In the account example, Account is a general-purpose class. However, a bank could have many different types of accounts: checking accounts, savings accounts, mortgage loans, and so forth, all of which have all the general characteristics of accounts but could have additional characteristics not shared by all types of accounts.

For example, a `CheckingAccount` class could have, in addition to the account number and account balance that all accounts have, a check fee that applies to each check written on the account. A `CheckingAccount` class also needs a method to process checks (that is, to read the amount, debit the payer, credit the payee, and so forth). So it makes sense to define `CheckingAccount` as a subclass of `Account`, and to define in the subclass the additional instance data and instance methods that the subclass needs.

As you design the `CheckingAccount` class, you discover the need for a class that models checks. An instance of class `Check` needs, at a minimum, instance data for payer, payee, and the check amount.

Many additional classes (and database and transaction-processing logic) would need to be designed in a real-world OO account system, but have been omitted to keep the example simple. The updated inheritance diagram is shown below.

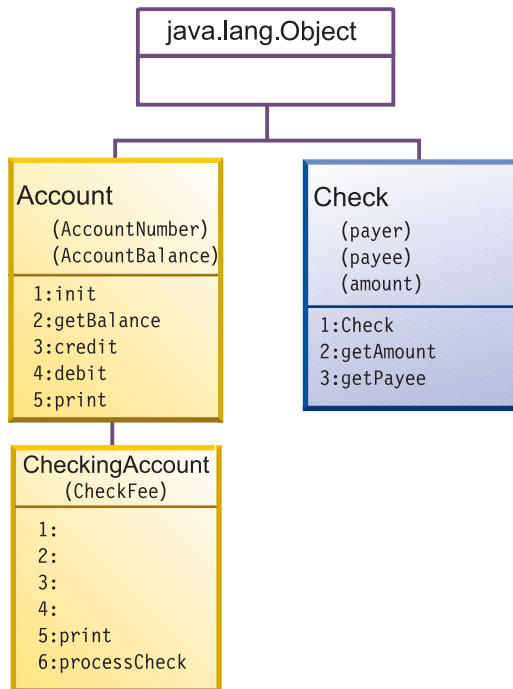

A number and colon with no method-name following them indicate that the method with that number is inherited from the superclass.

Multiple inheritance: You cannot use *multiple inheritance* in OO COBOL applications. All classes that you define must have exactly one parent, and `java.lang.Object` must be at the root of every inheritance hierarchy. The class structure of any object-oriented system defined in an OO COBOL application is thus a tree.

“Example: defining a method” on page 604

RELATED TASKS

“Defining a class”

“Defining a class instance method” on page 597

“Defining a subclass” on page 617

Defining a class

A COBOL class definition consists of an IDENTIFICATION DIVISION and ENVIRONMENT DIVISION, followed by an optional factory definition and optional object definition, followed by an END CLASS marker.

Table 75. Structure of class definitions

Section	Purpose	Syntax
IDENTIFICATION DIVISION (required)	Name the class. Provide inheritance information for it.	“CLASS-ID paragraph for defining a class” on page 594 (required) AUTHOR paragraph (optional) INSTALLATION paragraph (optional) DATE-WRITTEN paragraph (optional) DATE-COMPILED paragraph (optional)

Table 75. Structure of class definitions (continued)

Section	Purpose	Syntax
ENVIRONMENT DIVISION (required)	Describe the computing environment. Relate class-names used within the class definition to the corresponding external class-names known outside the compilation unit.	CONFIGURATION SECTION (required) "REPOSITORY paragraph for defining a class" on page 594 (required) SOURCE-COMPUTER paragraph (optional) OBJECT-COMPUTER paragraph (optional) SPECIAL-NAMES paragraph (optional)
Factory definition (optional)	Define data to be shared by all instances of the class, and methods supported independently of any object instance.	IDENTIFICATION DIVISION. FACTORY. DATA DIVISION. WORKING-STORAGE SECTION. * (Factory data here) PROCEDURE DIVISION. * (Factory methods here) END FACTORY.
Object definition (optional)	Define instance data and instance methods.	IDENTIFICATION DIVISION. OBJECT. DATA DIVISION. WORKING-STORAGE SECTION. * (Instance data here) PROCEDURE DIVISION. * (Instance methods here) END OBJECT.

If you specify the SOURCE-COMPUTER, OBJECT-COMPUTER, or SPECIAL-NAMES paragraphs in a class CONFIGURATION SECTION, they apply to the entire class definition including all methods that the class introduces.

A class CONFIGURATION SECTION can consist of the same entries as a program CONFIGURATION SECTION, except that a class CONFIGURATION SECTION cannot contain an INPUT-OUTPUT SECTION. You define an INPUT-OUTPUT SECTION only in the individual methods that require it rather than defining it at the class level.

As shown above, you define instance data and methods in the DATA DIVISION and PROCEDURE DIVISION, respectively, within the OBJECT paragraph of the class definition. In classes that require data and methods that are to be associated with the class itself rather than with individual object instances, define a separate DATA DIVISION and PROCEDURE DIVISION within the FACTORY paragraph of the class definition.

Each COBOL class definition must be in a separate source file.

"Example: defining a class" on page 597

RELATED TASKS

"WORKING-STORAGE SECTION for defining class instance data" on page 596

"Defining a class instance method" on page 597

"Defining a subclass" on page 617

"Defining a factory section" on page 621

"Describing the computing environment" on page 5

Chapter 16, "Compiling, linking, and running OO applications," on page 291

RELATED REFERENCES

COBOL class definition structure (*Enterprise COBOL Language Reference*)

CLASS-ID paragraph for defining a class

Use the CLASS-ID paragraph in the IDENTIFICATION DIVISION to name a class and provide inheritance information for it.

```
Identification Division.           Required  
Class-id. Account inherits Base. Required
```

Use the CLASS-ID paragraph to identify these classes:

- The class that you are defining (Account in the example above).
- The immediate superclass from which the class that you are defining inherits its characteristics. The superclass can be implemented in Java or COBOL.

In the example above, `inherits Base` indicates that the Account class inherits methods and data from the class known within the class definition as Base. It is recommended that you use the name Base in your OO COBOL programs to refer to `java.lang.Object`.

A class-name must use single-byte characters and must conform to the normal rules of formation for a COBOL user-defined word.

Use the REPOSITORY paragraph in the CONFIGURATION SECTION of the ENVIRONMENT DIVISION to associate the superclass name (Base in the example) with the name of the superclass as it is known externally (`java.lang.Object` for Base). You can optionally also specify the name of the class that you are defining (Account in the example) in the REPOSITORY paragraph and associate it with its corresponding external class-name.

You must derive all classes directly or indirectly from the `java.lang.Object` class.

RELATED TASKS

“REPOSITORY paragraph for defining a class”

RELATED REFERENCES

CLASS-ID paragraph (*Enterprise COBOL Language Reference*)

User-defined words (*Enterprise COBOL Language Reference*)

REPOSITORY paragraph for defining a class

Use the REPOSITORY paragraph to declare to the compiler that the specified words are class-names when you use them within a class definition, and to optionally relate the class-names to the corresponding external class-names (the class-names as they are known outside the compilation unit).

External class-names are case sensitive and must conform to Java rules of formation. For example, in the Account class definition you might code this:

```
Environment Division.           Required  
Configuration Section.         Required  
Repository.                     Required  
    Class Base is "java.lang.Object" Required  
    Class Account is "Account".     Optional
```

The REPOSITORY paragraph entries indicate that the external class-names of the classes referred to as Base and Account within the class definition are `java.lang.Object` and Account, respectively.

In the REPOSITORY paragraph, you must code an entry for each class-name that you explicitly reference in the class definition. For example:

- Base
- A superclass from which the class that you are defining inherits
- The classes that you reference in methods within the class definition

In a REPOSITORY paragraph entry, you must specify the external class-name if the name contains non-COBOL characters. You must also specify the external class-name for any referenced class that is part of a Java *package*. For such a class, specify the external class-name as the fully qualified name of the package, followed by period (`.`), followed by the simple name of the Java class. For example, the Object class is part of the `java.lang` package, so specify its external name as `java.lang.Object` as shown above.

An external class-name that you specify in the REPOSITORY paragraph must be an alphanumeric literal that conforms to the rules of formation for a fully qualified Java class-name.

If you do not include the external class-name in a REPOSITORY paragraph entry, the external class-name is formed from the class-name in the following manner:

- The class-name is converted to uppercase.
- Each hyphen is changed to zero.
- The first character, if a digit, is changed:
 - 1-9 are changed to A-I.
 - 0 is changed to J.
- Underscores are not changed.

In the example above, class Account is known externally as Account (in mixed case) because the external name is spelled using mixed case.

You can optionally include in the REPOSITORY paragraph an entry for the class that you are defining (Account in this example). You must include an entry for the class that you are defining if the external class-name contains non-COBOL characters, or to specify a fully package-qualified class-name if the class is to be part of a Java package.

“Example: external class-names and Java packages”

RELATED TASKS

“Declaring arrays and strings for Java” on page 639

RELATED REFERENCES

REPOSITORY paragraph (*Enterprise COBOL Language Reference*)

The Java Language Specification (Identifiers)

The Java Language Specification (Packages)

Example: external class-names and Java packages

The following example shows how external class-names are determined from entries in a REPOSITORY paragraph.

```

Environment division.
Configuration section.
Repository.
    Class Employee is "com.acme.Employee"
    Class JavaException is "java.lang.Exception"
    Class Orders.

```

The local class-names (the class-names as used within the class definition), the Java packages that contain the classes, and the associated external class-names are as shown in the table below.

Local class-name	Java package	External class-name
Employee	com.acme	com.acme.Employee
JavaException	java.lang	java.lang.Exception
Orders	(unnamed)	ORDERS

The external class-name (the name after the class-name and optional IS in the REPOSITORY paragraph entry) is composed of the fully qualified name of the package (if any) followed by a period, followed by the simple name of the class.

RELATED TASKS

“REPOSITORY paragraph for defining a class” on page 594

RELATED REFERENCES

REPOSITORY paragraph (*Enterprise COBOL Language Reference*)

WORKING-STORAGE SECTION for defining class instance data

Use the WORKING-STORAGE SECTION in the DATA DIVISION of the OBJECT paragraph to describe the *instance data* that a COBOL class needs, that is, the data to be allocated for each instance of the class.

The OBJECT keyword, which you must immediately precede with an IDENTIFICATION DIVISION declaration, indicates the beginning of the definitions of the instance data and instance methods for the class. For example, the definition of the instance data for the Account class might look like this:

```

IDENTIFICATION DIVISION.
Object.
    DATA DIVISION.
    WORKING-STORAGE SECTION.
    01 AccountNumber pic 9(6).
    01 AccountBalance pic S9(9) value zero.
    . . .
End Object.

```

The instance data is allocated when an object instance is created, and exists until garbage collection of the instance by the Java run time.

You can initialize simple instance data by using VALUE clauses as shown above. You can initialize more complex instance data by coding customized methods to create and initialize instances of classes.

COBOL instance data is equivalent to Java private nonstatic member data. No other class or subclass (nor factory method in the same class, if any) can reference COBOL instance data directly. Instance data is global to all instance methods that

the OBJECT paragraph defines. If you want to make instance data accessible from outside the OBJECT paragraph, define attribute (get or set) instance methods for doing so.

The syntax of the WORKING-STORAGE SECTION for instance data definition is generally the same as in a program, with these exceptions:

- You cannot use the EXTERNAL attribute.
- You can use the GLOBAL attribute, but it has no effect.

RELATED TASKS

“Creating and initializing instances of classes” on page 614

“Freeing instances of classes” on page 616

“Defining a factory method” on page 622

“Coding attribute (get and set) methods” on page 603

Example: defining a class

The following example shows a first attempt at the definition of the Account class, excluding method definitions.

```
cb1 dll,thread,pgmname(longmixed)
IDENTIFICATION DIVISION.
Class-id. Account inherits Base.
ENVIRONMENT DIVISION.
Configuration section.
Repository.
    Class Base is "java.lang.Object"
    Class Account is "Account".
*
IDENTIFICATION DIVISION.
Object.
DATA DIVISION.
WORKING-STORAGE SECTION.
01 AccountNumber pic 9(6).
01 AccountBalance pic S9(9) value zero.
*
PROCEDURE DIVISION.
*
* (Instance method definitions here)
*
End Object.
*
End class Account.
```

RELATED TASKS

Chapter 16, “Compiling, linking, and running OO applications,” on page 291

“Defining a client” on page 606

Defining a class instance method

Define COBOL *instance methods* in the PROCEDURE DIVISION of the OBJECT paragraph of a class definition. An instance method defines an operation that is supported for each object instance of a class.

A COBOL instance method definition consists of four divisions (like a COBOL program), followed by an END METHOD marker.

Table 76. Structure of instance method definitions

Division	Purpose	Syntax
IDENTIFICATION (required)	Name a method.	“METHOD-ID paragraph for defining a class instance method” (required) AUTHOR paragraph (optional) INSTALLATION paragraph (optional) DATE-WRITTEN paragraph (optional) DATE-COMPILED paragraph (optional)
ENVIRONMENT (optional)	Relate the file-names used in a method to the corresponding file-names known to the operating system.	“INPUT-OUTPUT SECTION for defining a class instance method” on page 599 (optional)
DATA (optional)	Define external files. Allocate a copy of the data.	“DATA DIVISION for defining a class instance method” on page 599 (optional)
PROCEDURE (optional)	Code the executable statements to complete the service provided by the method.	“PROCEDURE DIVISION for defining a class instance method” on page 600 (optional)

Definition: The *signature* of a method consists of the name of the method and the number and type of its formal parameters. (You define the formal parameters of a COBOL method in the USING phrase of the method's PROCEDURE DIVISION header.)

Within a class definition, you do not need to make each method-name unique, but you do need to give each method a unique signature. (You *overload* methods by giving them the same name but a different signature.)

COBOL instance methods are equivalent to Java public nonstatic methods.

“Example: defining a method” on page 604

RELATED TASKS

“PROCEDURE DIVISION for defining a class instance method” on page 600

“Overloading an instance method” on page 602

“Overriding an instance method” on page 601

“Invoking methods (INVOKE)” on page 610

“Defining a subclass instance method” on page 619

“Defining a factory method” on page 622

METHOD-ID paragraph for defining a class instance method

Use the METHOD-ID paragraph to name an instance method. Immediately precede the METHOD-ID paragraph with an IDENTIFICATION DIVISION declaration to indicate the beginning of the method definition.

For example, the definition of the credit method in the Account class begins like this:

```
Identification Division.
Method-id. "credit".
```

Code the method-name as an alphanumeric or national literal. The method-name is processed in a case-sensitive manner and must conform to the rules of formation for a Java method-name.

Other Java or COBOL methods or programs (that is, clients) use the method-name to invoke a method.

RELATED TASKS

“Invoking methods (INVOKE)” on page 610

“Using national data (Unicode) in COBOL” on page 130

RELATED REFERENCES

The Java Language Specification (Meaning of method names)

The Java Language Specification (Identifiers)

METHOD-ID paragraph (*Enterprise COBOL Language Reference*)

INPUT-OUTPUT SECTION for defining a class instance method

The ENVIRONMENT DIVISION of an instance method can have only one section, the INPUT-OUTPUT SECTION. This section relates the file-names used in a method definition to the corresponding file-names as they are known to the operating system.

For example, if the Account class defined a method that read information from a file, the Account class might have an INPUT-OUTPUT SECTION that is coded like this:

```
Environment Division.  
Input-Output Section.  
File-Control.  
    Select account-file Assign AcctFile.
```

The syntax for the INPUT-OUTPUT SECTION of a method is the same as the syntax for the INPUT-OUTPUT SECTION of a program.

RELATED TASKS

“Describing the computing environment” on page 5

RELATED REFERENCES

INPUT-OUTPUT section (*Enterprise COBOL Language Reference*)

DATA DIVISION for defining a class instance method

The DATA DIVISION of an instance method consists of any of the following four sections: FILE SECTION, LOCAL-STORAGE SECTION, WORKING-STORAGE SECTION, and LINKAGE SECTION.

FILE SECTION

The same as a program FILE SECTION, except that a method FILE SECTION can define EXTERNAL files only.

LOCAL-STORAGE SECTION

A separate copy of the LOCAL-STORAGE data is allocated for each invocation of the method, and is freed on return from the method. The method LOCAL-STORAGE SECTION is similar to a program LOCAL-STORAGE SECTION.

If you specify the VALUE clause on a data item, the item is initialized to that value on each invocation of the method.

WORKING-STORAGE SECTION

A single copy of the WORKING-STORAGE data is allocated. The data persists in

its last-used state until the run unit ends. The same copy of the data is used whenever the method is invoked, regardless of the invoking object or thread. The method WORKING-STORAGE SECTION is similar to a program WORKING-STORAGE SECTION.

If you specify the VALUE clause on a data item, the item is initialized to that value on the first invocation of the method. You can specify the EXTERNAL clause for the data items.

LINKAGE SECTION

The same as a program LINKAGE SECTION.

If you define a data item with the same name in both the DATA DIVISION of an instance method and the DATA DIVISION of the OBJECT paragraph, a reference in the method to that data-name refers only to the method data item. The method DATA DIVISION takes precedence.

RELATED TASKS

“Describing the data” on page 11

“Sharing data by using the EXTERNAL clause” on page 501

RELATED REFERENCES

DATA DIVISION overview (*Enterprise COBOL Language Reference*)

PROCEDURE DIVISION for defining a class instance method

Code the executable statements to implement the service that an instance method provides in the PROCEDURE DIVISION of the instance method.

You can code most COBOL statements in the PROCEDURE DIVISION of a method that you can code in the PROCEDURE DIVISION of a program. You cannot, however, code the following statements in a method:

- ENTRY
- EXIT PROGRAM
- The following obsolete elements of the 85 COBOL Standard:
 - ALTER
 - GOTO without a specified procedure-name
 - SEGMENT-LIMIT
 - USE FOR DEBUGGING

Additionally, because you must compile all COBOL class definitions with the THREAD compiler option, you cannot use SORT or MERGE statements in a COBOL method.

You can code the EXIT METHOD or GOBACK statement in an instance method to return control to the invoking client. Both statements have the same effect. If you specify the RETURNING phrase upon invocation of the method, the EXIT METHOD or GOBACK statement returns the value of the data item to the invoking client.

An implicit EXIT METHOD is generated as the last statement in the PROCEDURE DIVISION of each method.

You can specify STOP RUN in a method; doing so terminates the entire run unit including all threads executing within it.

You must terminate a method definition with an END METHOD marker. For example, the following statement marks the end of the credit method:

```
End method "credit".
```

USING phrase for obtaining passed arguments: Specify the formal parameters to a method, if any, in the USING phrase of the method's PROCEDURE DIVISION header. You must specify that the arguments are passed BY VALUE. Define each parameter as a level-01 or level-77 item in the method's LINKAGE SECTION. The data type of each parameter must be one of the types that are interoperable with Java.

RETURNING phrase for returning a value: Specify the data item to be returned as the method result, if any, in the RETURNING phrase of the method's PROCEDURE DIVISION header. Define the data item as a level-01 or level-77 item in the method's LINKAGE SECTION. The data type of the return value must be one of the types that are interoperable with Java.

RELATED TASKS

"Coding interoperable data types in COBOL and Java" on page 638

"Overriding an instance method"

"Overloading an instance method" on page 602

"Comparing and setting object references" on page 609

"Invoking methods (INVOKE)" on page 610

Chapter 16, "Compiling, linking, and running OO applications," on page 291

RELATED REFERENCES

"THREAD" on page 366

The procedure division header (*Enterprise COBOL Language Reference*)

Overriding an instance method

An instance method that is defined in a subclass is said to *override* an inherited instance method that would otherwise be accessible in the subclass if the two methods have the same signature.

To override a superclass instance method m1 in a COBOL subclass, define an instance method m1 in the subclass that has the same name and whose PROCEDURE DIVISION USING phrase (if any) has the same number and type of formal parameters as the superclass method has. (If the superclass method is implemented in Java, you must code formal parameters that are interoperable with the data types of the corresponding Java parameters.) When a client invokes m1 on an instance of the subclass, the subclass method rather than the superclass method is invoked.

For example, the Account class defines a method debit whose LINKAGE SECTION and PROCEDURE DIVISION header look like this:

```
Linkage section.  
01 inDebit    pic S9(9) binary.  
Procedure Division using by value inDebit.
```

If you define a CheckingAccount subclass and want it to have a debit method that overrides the debit method defined in the Account superclass, define the subclass method with exactly one input parameter also specified as pic S9(9) binary. If a client invokes debit using an object reference to a CheckingAccount instance, the CheckingAccount debit method (rather than the debit method in the Account superclass) is invoked.

The presence or absence of a method return value and the data type of the return value used in the PROCEDURE DIVISION RETURNING phrase (if any) must be identical in the subclass instance method and the overridden superclass instance method.

An instance method must not override a factory method in a COBOL superclass nor a static method in a Java superclass.

“Example: defining a method” on page 604

RELATED TASKS

“PROCEDURE DIVISION for defining a class instance method” on page 600

“Coding interoperable data types in COBOL and Java” on page 638

“Invoking methods (INVOKE)” on page 610

“Invoking overridden superclass methods” on page 614

“Defining a subclass” on page 617

“Hiding a factory or static method” on page 623

RELATED REFERENCES

The Java Language Specification (Inheritance, overriding, and hiding)

Overloading an instance method

Two methods that are supported in a class (whether defined in the class or inherited from a superclass) are said to be *overloaded* if they have the same name but different signatures.

You overload methods when you want to enable clients to invoke different versions of a method, for example, to initialize data using different sets of parameters.

To overload a method, define a method whose PROCEDURE DIVISION USING phrase (if any) has a different number or type of formal parameters than an identically named method that is supported in the same class. For example, the Account class defines an instance method `init` that has exactly one formal parameter. The LINKAGE SECTION and PROCEDURE DIVISION header of the `init` method look like this:

```
Linkage section.  
01 inAccountNumber pic S9(9) binary.  
Procedure Division using by value inAccountNumber.
```

Clients invoke this method to initialize an Account instance with a given account number (and a default account balance of zero) by passing exactly one argument that matches the data type of `inAccountNumber`.

But the Account class could define, for example, a second instance method `init` that has an additional formal parameter that allows the opening account balance to also be specified. The LINKAGE SECTION and PROCEDURE DIVISION header of this `init` method could look like this:

```
Linkage section.  
01 inAccountNumber pic S9(9) binary.  
01 inBalance      pic S9(9) binary.  
Procedure Division using by value inAccountNumber  
                                inBalance.
```

Clients could invoke either `init` method by passing arguments that match the signature of the required method.

The presence or absence of a method return value does not have to be consistent in overloaded methods, and the data type of the return value given in the PROCEDURE DIVISION RETURNING phrase (if any) does not have to be identical in overloaded methods.

You can overload factory methods in exactly the same way that you overload instance methods.

The rules for overloaded method definition and resolution of overloaded method invocations are based on the corresponding rules for Java.

RELATED TASKS

“Invoking methods (INVOKE)” on page 610

“Defining a factory method” on page 622

RELATED REFERENCES

The Java Language Specification (Overloading)

Coding attribute (get and set) methods

You can provide access to an instance variable *X* from outside the class in which *X* is defined by coding accessor (get) and mutator (set) methods for *X*.

Instance variables in COBOL are *private*: the class that defines instance variables fully encapsulates them, and only the instance methods defined in the same OBJECT paragraph can access them directly. Normally a well-designed object-oriented application does not need to access instance variables from outside the class.

COBOL does not directly support the concept of a public instance variable as defined in Java and other object-oriented languages, nor the concept of a class attribute as defined by CORBA. (A CORBA *attribute* is an instance variable that has an automatically generated get method for accessing the value of the variable, and an automatically generated set method for modifying the value of the variable if the variable is not read-only.)

“Example: coding a get method”

RELATED TASKS

“WORKING-STORAGE SECTION for defining class instance data” on page 596

“Processing the data” on page 17

Example: coding a get method

The following example shows the definition in the Account class of an instance method, `getBalance`, to return the value of the instance variable `AccountBalance` to a client. `getBalance` and `AccountBalance` are defined in the OBJECT paragraph of the Account class definition.

```
Identification Division.
Class-id. Account inherits Base.
* (ENVIRONMENT DIVISION not shown)
* (FACTORY paragraph not shown)
*
Identification division.
Object.
Data division.
WORKING-STORAGE SECTION.
01 AccountBalance pic S9(9) value zero.
* (Other instance data not shown)
*
```

```

Procedure Division.
*
  Identification Division.
  Method-id. "getBalance".
  Data division.
  Linkage section.
  01 outBalance pic S9(9) binary.
*
  Procedure Division returning outBalance.
  Move AccountBalance to outBalance.
  End method "getBalance".
*
* (Other instance methods not shown)
End Object.
*
End class Account.

```

Example: defining a method

The following example adds to the previous example the instance method definitions of the Account class, and shows the definition of the Java Check class.

(The previous example was "Example: defining a class" on page 597.)

Account class

```

cbl dll,thread,pgmname(longmixed)
Identification Division.
Class-id. Account inherits Base.
Environment Division.
Configuration section.
Repository.
  Class Base is "java.lang.Object"
  Class Account is "Account".
*
* (FACTORY paragraph not shown)
*
  Identification division.
  Object.
  Data division.
  Working-storage section.
  01 AccountNumber pic 9(6).
  01 AccountBalance pic S9(9) value zero.
*
  Procedure Division.
*
*   init method to initialize the account:
  Identification Division.
  Method-id. "init".
  Data division.
  Linkage section.
  01 inAccountNumber pic S9(9) binary.
  Procedure Division using by value inAccountNumber.
  Move inAccountNumber to AccountNumber.
  End method "init".
*
*   getBalance method to return the account balance:
  Identification Division.
  Method-id. "getBalance".
  Data division.
  Linkage section.
  01 outBalance pic S9(9) binary.
  Procedure Division returning outBalance.
  Move AccountBalance to outBalance.
  End method "getBalance".
*
*   credit method to deposit to the account:

```

```

    Identification Division.
    Method-id. "credit".
    Data division.
    Linkage section.
    01 inCredit    pic S9(9) binary.
    Procedure Division using by value inCredit.
        Add inCredit to AccountBalance.
    End method "credit".
*
*   debit method to withdraw from the account:
    Identification Division.
    Method-id. "debit".
    Data division.
    Linkage section.
    01 inDebit    pic S9(9) binary.
    Procedure Division using by value inDebit.
        Subtract inDebit from AccountBalance.
    End method "debit".
*
*   print method to display formatted account number and balance:
    Identification Division.
    Method-id. "print".
    Data division.
    Local-storage section.
    01 PrintableAccountNumber pic ZZZZZ999999.
    01 PrintableAccountBalance pic $$$,$$$,$$9CR.
    Procedure Division.
        Move AccountNumber to PrintableAccountNumber
        Move AccountBalance to PrintableAccountBalance
        Display " Account: " PrintableAccountNumber
        Display " Balance: " PrintableAccountBalance.
    End method "print".
*
    End Object.
*
    End class Account.

```

Check class

```

/**
 * A Java class for check information
 */
public class Check {
    private CheckingAccount payer;
    private Account         payee;
    private int              amount;

    public Check(CheckingAccount inPayer, Account inPayee, int inAmount) {
        payer=inPayer;
        payee=inPayee;
        amount=inAmount;
    }

    public int getAmount() {
        return amount;
    }

    public Account getPayee() {
        return payee;
    }
}

```

RELATED TASKS

Chapter 16, "Compiling, linking, and running OO applications," on page 291

Defining a client

A program or method that requests services from one or more methods in a class is called a *client* of that class.

In a COBOL or Java client, you can:

- Create object instances of Java and COBOL classes.
- Invoke instance methods on Java and COBOL objects.
- Invoke COBOL factory methods and Java static methods.

In a COBOL client, you can also call services provided by the Java Native Interface (JNI).

A COBOL client program consists of the usual four divisions:

Table 77. Structure of COBOL clients

Division	Purpose	Syntax
IDENTIFICATION (required)	Name a client.	Code as usual, except that a client program must be: <ul style="list-style-type: none">• Recursive (declared RECURSIVE in the PROGRAM-ID paragraph)• Thread-enabled (compiled with the THREAD option, and conforming to the coding guidelines for threaded applications)
ENVIRONMENT (required)	Describe the computing environment. Relate class-names used in the client to the corresponding external class-names known outside the compilation unit.	CONFIGURATION SECTION (required) “REPOSITORY paragraph for defining a client” on page 607 (required)
DATA (optional)	Describe the data that the client needs.	“DATA DIVISION for defining a client” on page 608 (optional)
PROCEDURE (optional)	Create instances of classes, manipulate object reference data items, and invoke methods.	Code using INVOKE, IF, and SET statements.

Because you must compile all COBOL programs that contain object-oriented syntax or that interoperate with Java with the THREAD compiler option, you cannot use the following language elements in a COBOL client:

- SORT or MERGE statements
- Nested programs

Any programs that you compile with the THREAD compiler option must be recursive. You must specify the RECURSIVE clause in the PROGRAM-ID paragraph of each OO COBOL client program.

“Example: defining a client” on page 616

RELATED TASKS

Chapter 16, "Compiling, linking, and running OO applications," on page 291
Chapter 27, "Preparing COBOL programs for multithreading," on page 517
Chapter 31, "Communicating with Java methods," on page 633
"Coding interoperable data types in COBOL and Java" on page 638
"Creating and initializing instances of classes" on page 614
"Comparing and setting object references" on page 609
"Invoking methods (INVOKE)" on page 610
"Invoking factory or static methods" on page 624

RELATED REFERENCES

"THREAD" on page 366

REPOSITORY paragraph for defining a client

Use the REPOSITORY paragraph to declare to the compiler that the specified words are class-names when you use them in a COBOL client, and to optionally relate the class-names to the corresponding external class-names (the class-names as they are known outside the compilation unit).

External class-names are case sensitive, and must conform to Java rules of formation. For example, in a client program that uses the Account and Check classes you might code this:

```
Environment division.      Required  
Configuration section.    Required  
    Source-Computer.      IBM-390.  
    Object-Computer.     IBM-390.  
Repository.               Required  
    Class Account is "Account"  
    Class Check  is "Check".
```

The REPOSITORY paragraph entries indicate that the external class-names of the classes referred to as Account and Check within the client are Account and Check, respectively.

In the REPOSITORY paragraph, you must code an entry for each class-name that you explicitly reference in the client. In a REPOSITORY paragraph entry, you must specify the external class-name if the name contains non-COBOL characters.

You must specify the external class-name for any referenced class that is part of a Java package. For such a class, specify the external class-name as the fully qualified name of the package, followed by period (.), followed by the simple name of the Java class.

An external class-name that you specify in the REPOSITORY paragraph must be an alphanumeric literal that conforms to the rules of formation for a fully qualified Java class-name.

If you do not include the external class-name in a REPOSITORY paragraph entry, the external class-name is formed from the class-name in the same manner as it is when an external class-name is not included in a REPOSITORY paragraph entry in a class definition. In the example above, class Account and class Check are known externally as Account and Check (in mixed case), respectively, because the external names are spelled using mixed case.

The SOURCE-COMPUTER, OBJECT-COMPUTER, and SPECIAL-NAMES paragraphs of the CONFIGURATION SECTION are optional.

RELATED TASKS

“REPOSITORY paragraph for defining a class” on page 594

RELATED REFERENCES

REPOSITORY paragraph (*Enterprise COBOL Language Reference*)

The Java Language Specification (Identifiers)

The Java Language Specification (Packages)

DATA DIVISION for defining a client

You can use any of the sections of the DATA DIVISION to describe the data that the client needs.

Data Division.

Local-storage section.

```
01  anAccount          usage object reference Account.
01  aCheckingAccount  usage object reference CheckingAccount.
01  aCheck            usage object reference Check.
01  payee             usage object reference Account.
. . .
```

Because a client references classes, it needs one or more special data items called *object references*, that is, references to instances of those classes. All requests to instance methods require an object reference to an instance of a class in which the method is supported (that is, either defined or available by inheritance). You code object references to refer to instances of Java classes using the same syntax as you use to refer to instances of COBOL classes. In the example above, the phrase *usage object reference* indicates an object reference data item.

All four object references in the code above are called *typed* object references because a class-name appears after the OBJECT REFERENCE phrase. A typed object reference can refer only to an instance of the class named in the OBJECT REFERENCE phrase or to one of its subclasses. Thus *anAccount* can refer to instances of the *Account* class or one of its subclasses, but cannot refer to instances of any other class. Similarly, *aCheck* can refer only to instances of the *Check* class or any subclasses that it might have.

Another type of object reference, not shown above, does not have a class-name after the OBJECT REFERENCE phrase. Such a reference is called a *universal* object reference, which means that it can refer to instances of any class. Avoid coding universal object references, because they are interoperable with Java in only very limited circumstances (when used in the RETURNING phrase of the INVOKE *class-name NEW . . .* statement).

You must define, in the REPOSITORY paragraph of the CONFIGURATION SECTION, class-names that you use in the OBJECT REFERENCE phrase.

RELATED TASKS

“Choosing LOCAL-STORAGE or WORKING-STORAGE” on page 609

“Coding interoperable data types in COBOL and Java” on page 638

“Invoking methods (INVOKE)” on page 610

“REPOSITORY paragraph for defining a client” on page 607

RELATED REFERENCES

RETURNING phrase (*Enterprise COBOL Language Reference*)

Choosing LOCAL-STORAGE or WORKING-STORAGE

You can in general use the WORKING-STORAGE SECTION to define working data that a client program needs. However, if the program could simultaneously run on multiple threads, you might instead want to define the data in the LOCAL-STORAGE SECTION.

Each thread has access to a separate copy of LOCAL-STORAGE data but shares access to a single copy of WORKING-STORAGE data. If you define the data in the WORKING-STORAGE SECTION, you need to synchronize access to the data or ensure that no two threads can access it simultaneously.

RELATED TASKS

Chapter 27, "Preparing COBOL programs for multithreading," on page 517

Comparing and setting object references

You can compare object references by coding conditional statements or a call to the JNI service `IsSameObject`, and you can set object references by using the `SET` statement.

For example, code either IF statement below to check whether the object reference `anAccount` refers to no object instance:

```
If anAccount = Null . . .  
If anAccount = Nulls . . .
```

You can code a call to `IsSameObject` to check whether two object references, `object1` and `object2`, refer to the same object instance or whether each refers to no object instance. To ensure that the arguments and return value are interoperable with Java and to establish addressability to the callable service, code the following data definitions and statements before the call to `IsSameObject`:

Local-storage Section.

```
. . .  
01 is-same Pic X.  
   88 is-same-false Value X'00'.  
   88 is-same-true  Value X'01' Through X'FF'.
```

Linkage Section.

Copy JNI.

Procedure Division.

```
Set Address Of JNIEnv To JNIEnvPtr  
Set Address Of JNINativeInterface To JNIEnv  
Call IsSameObject Using By Value JNIEnvPtr object1 object2  
   Returning is-same  
If is-same-true . . .
```

Within a method you can check whether an object reference refers to the object instance on which the method was invoked by coding a call to `IsSameObject` that compares the object reference and `SELF`.

You can instead invoke the Java `equals` method (inherited from `java.lang.Object`) to determine whether two object references refer to the same object instance.

You can make an object reference refer to no object instance by using the `SET` statement. For example:

```
Set anAccount To Null.
```

You can also make one object reference refer to the same instance as another object reference does by using the `SET` statement. For example:

```
Set anotherAccount To anAccount.
```

This SET statement causes anotherAccount to refer to the same object instance as anAccount does. If the receiver (anotherAccount) is a universal object reference, the sender (anAccount) can be either a universal or a typed object reference. If the receiver is a typed object reference, the sender must be a typed object reference bound to the same class as the receiver or to one of its subclasses.

Within a method you can make an object reference refer to the object instance on which the method was invoked by setting it to SELF. For example:

```
Set anAccount To Self.
```

RELATED TASKS

“Coding interoperable data types in COBOL and Java” on page 638

“Accessing JNI services” on page 633

RELATED REFERENCES

The Java Native Interface (IsSameObject)

Invoking methods (INVOKE)

In a Java client, you can create object instances of classes that were implemented in COBOL and invoke methods on those objects using standard Java syntax. In a COBOL client, you can invoke methods that are defined in Java or COBOL classes by coding the INVOKE statement.

```
Invoke Account "createAccount"  
    using by value 123456  
    returning anAccount  
Invoke anAccount "credit" using by value 500.
```

The first example INVOKE statement above uses the class-name Account to invoke a method called createAccount. This method must be either defined or inherited in the Account class, and must be one of the following types:

- A Java static method
- A COBOL factory method

The phrase using by value 123456 indicates that 123456 is an input argument to the method, and is passed by value. The input argument 123456 and the returned data item anAccount must conform to the definition of the formal parameters and return type, respectively, of the (possibly overloaded) createAccount method.

The second INVOKE statement uses the returned object reference anAccount to invoke the instance method credit, which is defined in the Account class. The input argument 500 must conform to the definition of the formal parameters of the (possibly overloaded) credit method.

Code the name of the method to be invoked either as a literal or as an identifier whose value at run time matches the method-name in the signature of the target method. The method-name must be an alphanumeric or national literal or a category alphabetic, alphanumeric, or national data item, and is interpreted in a case-sensitive manner.

When you code an INVOKE statement using an object reference (as in the second example statement above), the statement begins with one of the following two forms:

```
Invoke objRef "literal-name" . . .  
Invoke objRef identifier-name . . .
```

When the method-name is an identifier, you must define the object reference (objRef) as USAGE OBJECT REFERENCE with no specified type, that is, as a universal object reference.

If an invoked method is not supported in the class to which the object reference refers, a severity-3 Language Environment condition is raised at run time unless you code the ON EXCEPTION phrase in the INVOKE statement.

You can use the optional scope terminator END-INVOKE with the INVOKE statement.

The INVOKE statement does not set the RETURN-CODE special register.

RELATED TASKS

- “USING phrase for passing arguments”
- “RETURNING phrase for obtaining a returned value” on page 613
- “PROCEDURE DIVISION for defining a class instance method” on page 600
- “Coding interoperable data types in COBOL and Java” on page 638
- “Invoking overridden superclass methods” on page 614
- “Invoking factory or static methods” on page 624

RELATED REFERENCES

INVOKE statement (*Enterprise COBOL Language Reference*)

USING phrase for passing arguments

If you pass arguments to a method, specify the arguments in the USING phrase of the INVOKE statement. Code the data type of each argument so that it conforms to the type of the corresponding formal parameter in the intended target method.

Table 78. Conformance of arguments in a COBOL client

Programming language of the target method	Is the argument an object reference?	Then code the DATA DIVISION definition of the argument as:	Restriction
COBOL	No	The same as the definition of the corresponding formal parameter	
Java	No	Interoperable with the corresponding Java parameter	
COBOL or Java	Yes	An object reference that is typed to the same class as the corresponding parameter in the target method	In a COBOL client (unlike in a Java client), the class of an argument cannot be a subclass of the class of the corresponding parameter.

See the example referenced below for a way to make an object-reference argument conform to the type of a corresponding formal parameter by using the SET statement or the REDEFINES clause.

“Example: passing conforming object-reference arguments from a COBOL client” on page 612

If the target method is overloaded, the data types of the arguments are used to select from among the methods that have the same name.

You must specify that the arguments are passed BY VALUE. In other words, the arguments are not affected by any change to the corresponding formal parameters in the invoked method.

The data type of each argument must be one of the types that are interoperable with Java.

RELATED TASKS

“PROCEDURE DIVISION for defining a class instance method” on page 600

“Overloading an instance method” on page 602

“Coding interoperable data types in COBOL and Java” on page 638

“Passing data” on page 491

RELATED REFERENCES

INVOKE statement (*Enterprise COBOL Language Reference*)

SET statement (*Enterprise COBOL Language Reference*)

REDEFINES clause (*Enterprise COBOL Language Reference*)

Example: passing conforming object-reference arguments from a COBOL client

The following example shows a way to make an object-reference argument in a COBOL client conform to the expected class of the corresponding formal parameter in an invoked method.

Class C defines a method M that has one parameter, a reference to an object of class `java.lang.Object`:

```
. . .
Class-id. C inherits Base.
. . .
Repository.
    Class Base      is "java.lang.Object"
    Class JavaObject is "java.lang.Object".
Identification division.
Factory.
. . .
Procedure Division.
    Identification Division.
    Method-id. "M".
    Data division.
    Linkage section.
    01 obj object reference JavaObject.
    Procedure Division using by value obj.
. . .
```

To invoke method M, a COBOL client must pass an argument that is a reference to an object of class `java.lang.Object`. The client below defines a data item `aString`, which cannot be passed as an argument to M because `aString` is a reference to an object of class `java.lang.String`. The client first uses a SET statement to assign `aString` to a data item, `anObj`, that is a reference to an object of class `java.lang.Object`. (This SET statement is legal because `java.lang.String` is a subclass of `java.lang.Object`.) The client then passes `anObj` as the argument to M.

```
. . .
Repository.
    Class jstring   is "java.lang.String"
    Class JavaObject is "java.lang.Object".
Data division.
Local-storage section.
01 aString object reference jstring.
01 anObj  object reference JavaObject.
*
```

```

Procedure division.
  . . . (statements here assign a value to aString)
  Set anObj to aString
  Invoke C "M"
    using by value anObj

```

Instead of using a SET statement to obtain anObj as a reference to an object of class java.lang.Object, the client could define aString and anObj with the REDEFINES clause as follows:

```

. . .
01 aString object reference jstring.
01 anObj redefines aString object reference JavaObject.

```

After the client assigns a value to data item aString (that is, a valid reference to an object of class java.lang.String), anObj can be passed as the argument to M. For an example of the use of the REDEFINES clause to obtain argument conformance, see the example referenced below.

“Example: J2EE client written in COBOL” on page 644

RELATED TASKS

“Coding interoperable data types in COBOL and Java” on page 638

“PROCEDURE DIVISION for defining a class instance method” on page 600

RELATED REFERENCES

INVOKE statement (*Enterprise COBOL Language Reference*)

SET statement (*Enterprise COBOL Language Reference*)

REDEFINES clause (*Enterprise COBOL Language Reference*)

RETURNING phrase for obtaining a returned value

If a data item is to be returned as the method result, specify the item in the RETURNING phrase of the INVOKE statement. Define the returned item in the DATA DIVISION of the client.

The item that you specify in the RETURNING phrase of the INVOKE statement must conform to the type returned by the target method, as shown in the table below.

Table 79. Conformance of the returned data item in a COBOL client

Programming language of the target method	Is the returned item an object reference?	Then code the DATA DIVISION definition of the returned item as:
COBOL	No	The same as the definition of the RETURNING item in the target method
Java	No	Interoperable with the returned Java data item
COBOL or Java	Yes	An object reference that is typed to the same class as the object reference that is returned by the target method

In all cases, the data type of the returned value must be one of the types that are interoperable with Java.

RELATED TASKS

“Coding interoperable data types in COBOL and Java” on page 638

RELATED REFERENCES

INVOKE statement (*Enterprise COBOL Language Reference*)

Invoking overridden superclass methods

Sometimes within a class you need to invoke an overridden superclass method instead of invoking a method that has the same signature and is defined in the current class.

For example, suppose that the `CheckingAccount` class overrides the `debit` instance method defined in its immediate superclass, `Account`. You could invoke the `Account` `debit` method within a method in the `CheckingAccount` class by coding this statement:

```
Invoke Super "debit" Using By Value amount.
```

You would define `amount` as `PIC S9(9) BINARY` to match the signature of the `debit` methods.

The `CheckingAccount` class overrides the `print` method that is defined in the `Account` class. Because the `print` method has no formal parameters, a method in the `CheckingAccount` class could invoke the superclass `print` method with this statement:

```
Invoke Super "print".
```

The keyword `SUPER` indicates that you want to invoke a superclass method rather than a method in the current class. (`SUPER` is an implicit reference to the object used in the invocation of the currently executing method.)

“Example: accounts” on page 590

RELATED TASKS

“Overriding an instance method” on page 601

RELATED REFERENCES

INVOKE statement (*Enterprise COBOL Language Reference*)

Creating and initializing instances of classes

Before you can use the instance methods that are defined in a Java or COBOL class, you must first create an instance of the class.

To create a new instance of class *class-name* and to obtain a reference *object-reference* to the created object, code a statement of the following form, where *object-reference* is defined in the DATA DIVISION of the client:

```
INVOKE class-name NEW . . . RETURNING object-reference
```

When you code the `INVOKE . . . NEW` statement within a method, and the use of the returned object reference is not limited to the duration of the method invocation, you must convert the returned object reference to a global reference by calling the JNI service `NewGlobalRef`:

```
Call NewGlobalRef using by value JNIEnvPtr object-reference  
returning object-reference
```

If you do not call `NewGlobalRef`, the returned object reference is only a local reference, which means that it is automatically freed after the method returns.

RELATED TASKS

“Instantiating Java classes”

“Instantiating COBOL classes”

“Accessing JNI services” on page 633

“Managing local and global references” on page 636

“DATA DIVISION for defining a client” on page 608

“Invoking methods (INVOKE)” on page 610

“Coding interoperable data types in COBOL and Java” on page 638

RELATED REFERENCES

INVOKE statement (*Enterprise COBOL Language Reference*)

Instantiating Java classes

To instantiate a Java class, invoke any parameterized constructor that the class supports by coding the USING phrase in the INVOKE . . . NEW statement immediately before the RETURNING phrase, passing BY VALUE the number and types of arguments that match the signature of the constructor.

The data type of each argument must be one of the types that are interoperable with Java. To invoke the default (parameterless) constructor, omit the USING phrase.

For example, to create an instance of the Check class, initialize its instance data, and obtain reference aCheck to the Check instance created, you could code this statement in a COBOL client:

```
Invoke Check New
  using by value aCheckingAccount, payee, 125
  returning aCheck
```

RELATED TASKS

“Invoking methods (INVOKE)” on page 610

“Coding interoperable data types in COBOL and Java” on page 638

RELATED REFERENCES

VALUE clause (*Enterprise COBOL Language Reference*)

INVOKE statement (*Enterprise COBOL Language Reference*)

Instantiating COBOL classes

To instantiate a COBOL class, you can specify either a typed or universal object reference in the RETURNING phrase of the INVOKE . . . NEW statement. However, you cannot code the USING phrase: the instance data is initialized as specified in the VALUE clauses in the class definition.

Thus the INVOKE . . . NEW statement is useful for instantiating COBOL classes that have only simple instance data. For example, the following statement creates an instance of the Account class, initializes the instance data as specified in VALUE clauses in the WORKING-STORAGE SECTION of the OBJECT paragraph of the Account class definition, and provides reference outAccount to the new instance:

```
Invoke Account New returning outAccount
```

To make it possible to initialize COBOL instance data that cannot be initialized using VALUE clauses alone, when designing a COBOL class you must define a parameterized creation method in the FACTORY paragraph and a parameterized initialization method in the OBJECT paragraph:

1. In the parameterized factory creation method, do these steps:

- a. Code `INVOKE class-name NEW RETURNING objectRef` to create an instance of `class-name` and to give initial values to the instance data items that have `VALUE` clauses.
 - b. Invoke the parameterized initialization method on the instance (`objectRef`), passing `BY VALUE` the arguments that were supplied to the factory method.
2. In the initialization method, code logic to complete the instance data initialization using the values supplied through the formal parameters.

To create an instance of the COBOL class and properly initialize it, the client invokes the parameterized factory method, passing `BY VALUE` the required arguments. The object reference returned to the client is a local reference. If the client code is within a method, and the use of the returned object reference is not limited to the duration of that method, the client code must convert the returned object reference to a global reference by calling the JNI service `NewGlobalRef`.

“Example: defining a factory (with methods)” on page 625

RELATED TASKS

“Accessing JNI services” on page 633

“Managing local and global references” on page 636

“Invoking methods (INVOKE)” on page 610

“Defining a factory section” on page 621

RELATED REFERENCES

`VALUE` clause (*Enterprise COBOL Language Reference*)

`INVOKE` statement (*Enterprise COBOL Language Reference*)

Freeing instances of classes

You do not need to take any action to free individual object instances of any class. No syntax is available for doing so. The Java runtime system automatically performs *garbage collection*, that is, it reclaims the memory for objects that are no longer in use.

There could be times, however, when you need to explicitly free local or global references to objects within a native COBOL client in order to permit garbage collection of the referenced objects to occur.

RELATED TASKS

“Managing local and global references” on page 636

Example: defining a client

The following example shows a small client program of the `Account` class.

The program does this:

- Invokes a factory method `createAccount` to create an `Account` instance with a default balance of zero
- Invokes the instance method `credit` to deposit \$500 to the new account
- Invokes the instance method `print` to display the account status

(The `Account` class was shown in “Example: defining a method” on page 604.)

```
cb1 dll,thread,pgmname(longmixed)
Identification division.
Program-id. "TestAccounts" recursive.
Environment division.
```



```

Configuration section.
Repository.
    Class Account is "Account".
Data Division.
* Working data is declared in LOCAL-STORAGE instead of
* WORKING-STORAGE so that each thread has its own copy:
Local-storage section.
01 anAccount usage object reference Account.
*
Procedure division.
Test-Account-section.
    Display "Test Account class"
* Create account 123456 with 0 balance:
    Invoke Account "createAccount"
        using by value 123456
        returning anAccount
* Deposit 500 to the account:
    Invoke anAccount "credit" using by value 500
    Invoke anAccount "print"
    Display space
*
    Stop Run.
End program "TestAccounts".

```

“Example: defining a factory (with methods)” on page 625

RELATED TASKS

“Defining a factory method” on page 622

“Invoking factory or static methods” on page 624

Chapter 16, “Compiling, linking, and running OO applications,” on page 291

Defining a subclass

You can make a class (called a *subclass*, derived class, or child class) a specialization of another class (called a *superclass*, base class, or parent class).

A subclass inherits the methods and instance data of its superclasses, and is related to its superclasses by an *is-a* relationship. For example, if subclass P inherits from superclass Q, and subclass Q inherits from superclass S, then an instance of P is an instance of Q and also (by transitivity) an instance of S. An instance of P inherits the methods and data of Q and S.

Using subclasses has several advantages:

- **Reuse of code:** Through inheritance, a subclass can reuse methods that already exist in a superclass.
- **Specialization:** In a subclass you can add new methods to handle cases that the superclass does not handle. You can also add new data items that the superclass does not need.
- **Change in action:** A subclass can override a method that it inherits from a superclass by defining a method of the same signature as that in the superclass. When you override a method, you might make only a few minor changes or completely change what the method does.

Restriction: You cannot use *multiple inheritance* in your COBOL programs. Each COBOL class that you define must have exactly one immediate superclass that is implemented in Java or COBOL, and each class must be derived directly or indirectly from `java.lang.Object`. The semantics of inheritance are as defined by Java.

The structure and syntax of a subclass definition are identical to those of a class definition: Define instance data and methods in the DATA DIVISION and PROCEDURE DIVISION, respectively, within the OBJECT paragraph of the subclass definition. In subclasses that require data and methods that are to be associated with the subclass itself rather than with individual object instances, define a separate DATA DIVISION and PROCEDURE DIVISION within the FACTORY paragraph of the subclass definition.

COBOL instance data is private. A subclass can access the instance data of a COBOL superclass only if the superclass defines attribute (get or set) instance methods for doing so.

“Example: accounts” on page 590

“Example: defining a subclass (with methods)” on page 620

RELATED TASKS

“Defining a class” on page 592

“Overriding an instance method” on page 601

“Coding attribute (get and set) methods” on page 603

“Defining a subclass instance method” on page 619

“Defining a factory section” on page 621

RELATED REFERENCES

The Java Language Specification (Inheritance, overriding, and hiding)

COBOL class definition structure (*Enterprise COBOL Language Reference*)

CLASS-ID paragraph for defining a subclass

Use the CLASS-ID paragraph to name the subclass and indicate from which immediate Java or COBOL superclass it inherits its characteristics.

Identification Division.

Required

Class-id. CheckingAccount inherits Account. **Required**

In the example above, CheckingAccount is the subclass being defined. CheckingAccount inherits all the methods of the class known within the subclass definition as Account. CheckingAccount methods can access Account instance data only if the Account class provides attribute (get or set) methods for doing so.

You must specify the name of the immediate superclass in the REPOSITORY paragraph in the CONFIGURATION SECTION of the ENVIRONMENT DIVISION. You can optionally associate the superclass name with the name of the class as it is known externally. You can also specify the name of the subclass that you are defining (here, CheckingAccount) in the REPOSITORY paragraph and associate it with its corresponding external class-name.

RELATED TASKS

“CLASS-ID paragraph for defining a class” on page 594

“Coding attribute (get and set) methods” on page 603

“REPOSITORY paragraph for defining a subclass”

REPOSITORY paragraph for defining a subclass

Use the REPOSITORY paragraph to declare to the compiler that the specified words are class-names when you use them within a subclass definition, and to optionally relate the class-names to the corresponding external class-names (the class-names as they are known outside the compilation unit).

For example, in the CheckingAccount subclass definition, these REPOSITORY paragraph entries indicate that the external class-names of the classes referred to as CheckingAccount, Check, and Account within the subclass definition are CheckingAccount, Check, and Account, respectively.

Environment Division.		Required
Configuration Section.		Required
Repository.		Required
Class CheckingAccount	is "CheckingAccount"	Optional
Class Check	is "Check"	Required
Class Account	is "Account".	Required

In the REPOSITORY paragraph, you must code an entry for each class-name that you explicitly reference in the subclass definition. For example:

- A user-defined superclass from which the subclass that you are defining inherits
- The classes that you reference in methods within the subclass definition

The rules for coding REPOSITORY paragraph entries in a subclass are identical to those for coding REPOSITORY paragraph entries in a class.

RELATED TASKS

“REPOSITORY paragraph for defining a class” on page 594

RELATED REFERENCES

REPOSITORY paragraph (*Enterprise COBOL Language Reference*)

WORKING-STORAGE SECTION for defining subclass instance data

Use the WORKING-STORAGE SECTION in the DATA DIVISION of the subclass OBJECT paragraph to describe any instance data that the subclass needs in addition to the instance data defined in its superclasses. Use the same syntax that you use to define instance data in a class.

For example, the definition of the instance data for the CheckingAccount subclass of the Account class might look like this:

```
IDENTIFICATION DIVISION.  
Object.  
DATA DIVISION.  
WORKING-STORAGE SECTION.  
01 CheckFee pic S9(9) value 1.  
.  
.  
End Object.
```

RELATED TASKS

“WORKING-STORAGE SECTION for defining class instance data” on page 596

Defining a subclass instance method

A subclass inherits the methods of its superclasses. In a subclass definition, you can override any instance method that the subclass inherits by defining an instance method with the same signature as the inherited method. You can also define new methods that the subclass needs.

The structure and syntax of a subclass instance method are identical to those of a class instance method. Define subclass instance methods in the PROCEDURE DIVISION of the OBJECT paragraph of the subclass definition.

“Example: defining a subclass (with methods)” on page 620

RELATED TASKS

"Defining a class instance method" on page 597

"Overriding an instance method" on page 601

"Overloading an instance method" on page 602

Example: defining a subclass (with methods)

The following example shows the instance method definitions for the CheckingAccount subclass of the Account class.

The processCheck method invokes the Java instance methods getAmount and getPayee of the Check class to get the check data. It invokes the credit and debit instance methods inherited from the Account class to credit the payee and debit the payer of the check.

The print method overrides the print instance method defined in the Account class. It invokes the overridden print method to display account status, and also displays the check fee. CheckFee is an instance data item defined in the subclass.

(The Account class was shown in "Example: defining a method" on page 604.)

CheckingAccount class (subclass of Account)

```
cb1 dll,thread,pgmname(longmixed)
Identification Division.
Class-id. CheckingAccount inherits Account.
Environment Division.
Configuration section.
Repository.
    Class CheckingAccount is "CheckingAccount"
    Class Check          is "Check"
    Class Account        is "Account".
*
* (FACTORY paragraph not shown)
*
Identification division.
Object.
Data division.
Working-storage section.
01 CheckFee pic S9(9) value 1.
Procedure Division.
*
*   processCheck method to get the check amount and payee,
*   add the check fee, and invoke inherited methods debit
*   to debit the payer and credit to credit the payee:
Identification Division.
Method-id. "processCheck".
Data division.
Local-storage section.
01 amount pic S9(9) binary.
01 payee usage object reference Account.
Linkage section.
01 aCheck usage object reference Check.
*
Procedure Division using by value aCheck.
    Invoke aCheck "getAmount" returning amount
    Invoke aCheck "getPayee" returning payee
    Invoke payee "credit" using by value amount
    Add checkFee to amount
    Invoke self "debit" using by value amount.
End method "processCheck".
*
*   print method override to display account status:
Identification Division.
```

```

Method-id. "print".
Data division.
Local-storage section.
01 printableFee pic $$,$$$,$$9.
Procedure Division.
    Invoke super "print"
    Move CheckFee to printableFee
    Display " Check fee: " printableFee.
End method "print".
*
End Object.
*
End class CheckingAccount.

```

RELATED TASKS

Chapter 16, “Compiling, linking, and running OO applications,” on page 291
 “Invoking methods (INVOKE)” on page 610
 “Overriding an instance method” on page 601
 “Invoking overridden superclass methods” on page 614

Defining a factory section

Use the `FACTORY` paragraph in a class definition to define data and methods that are to be associated with the class itself rather than with individual object instances.

COBOL *factory data* is equivalent to Java private static data. A single copy of the data is instantiated for the class and is shared by all object instances of the class. You most commonly use factory data when you want to gather data from all the instances of a class. For example, you could define a factory data item to keep a running total of the number of instances of the class that are created.

COBOL *factory methods* are equivalent to Java public static methods. The methods are supported by the class independently of any object instance. You most commonly use factory methods to customize object creation when you cannot use `VALUE` clauses alone to initialize instance data.

By contrast, you use the `OBJECT` paragraph in a class definition to define data that is created for each object instance of the class, and methods that are supported for each object instance of the class.

A factory definition consists of three divisions, followed by an `END FACTORY` statement:

Table 80. Structure of factory definitions

Division	Purpose	Syntax
IDENTIFICATION (required)	Identify the start of the factory definition.	IDENTIFICATION DIVISION. FACTORY.
DATA (optional)	Describe data that is allocated once for the class (as opposed to data allocated for each instance of a class).	“WORKING-STORAGE SECTION for defining factory data” on page 622 (optional)
PROCEDURE (optional)	Define factory methods.	Factory method definitions: “Defining a factory method” on page 622

“Example: defining a factory (with methods)” on page 625

RELATED TASKS

“Defining a class” on page 592

“Instantiating COBOL classes” on page 615

“Wrapping procedure-oriented COBOL programs” on page 630

“Structuring OO applications” on page 630

WORKING-STORAGE SECTION for defining factory data

Use the WORKING-STORAGE SECTION in the DATA DIVISION of the FACTORY paragraph to describe the *factory data* that a COBOL class needs, that is, statically allocated data to be shared by all object instances of the class.

The FACTORY keyword, which you must immediately precede with an IDENTIFICATION DIVISION declaration, indicates the beginning of the definitions of the factory data and factory methods for the class. For example, the definition of the factory data for the Account class might look like this:

```
IDENTIFICATION DIVISION.  
Factory.  
DATA DIVISION.  
WORKING-STORAGE SECTION.  
01 NumberOfAccounts pic 9(6) value zero.  
.  
.  
End Factory.
```

You can initialize simple factory data by using VALUE clauses as shown above.

COBOL factory data is equivalent to Java private static data. No other class or subclass (nor instance method in the same class, if any) can reference COBOL factory data directly. Factory data is global to all factory methods that the FACTORY paragraph defines. If you want to make factory data accessible from outside the FACTORY paragraph, define factory attribute (get or set) methods for doing so.

RELATED TASKS

“Coding attribute (get and set) methods” on page 603

“Instantiating COBOL classes” on page 615

Defining a factory method

Define COBOL *factory methods* in the PROCEDURE DIVISION of the FACTORY paragraph of a class definition. A factory method defines an operation that is supported by a class independently of any object instance of the class. COBOL factory methods are equivalent to Java public static methods.

You typically define factory methods for classes whose instances require complex initialization, that is, to values that you cannot assign by using VALUE clauses alone. Within a factory method you can invoke instance methods to initialize the instance data. A factory method cannot directly access instance data.

You can code factory attribute (get and set) methods to make factory data accessible from outside the FACTORY paragraph, for example, to make the data accessible from instance methods in the same class or from a client program. For example, the Account class could define a factory method getNumberOfAccounts to return the current tally of the number of accounts.

You can use factory methods to wrap procedure-oriented COBOL programs so that they are accessible from Java programs. You can code a factory method called main

to enable you to run an OO application by using the java command, and to structure your applications in keeping with standard Java practice. See the related tasks for details.

In defining factory methods, you use the same syntax that you use to define instance methods. A COBOL factory method definition consists of four divisions (like a COBOL program), followed by an END METHOD marker:

Table 81. Structure of factory method definitions

Division	Purpose	Syntax
IDENTIFICATION (required)	Same as for a class instance method	Same as for a class instance method (required)
ENVIRONMENT (optional)	Same as for a class instance method	Same as for a class instance method
DATA (optional)	Same as for a class instance method	Same as for a class instance method
PROCEDURE (optional)	Same as for a class instance method	Same as for a class instance method

Within a class definition, you do not need to make each factory method-name unique, but you do need to give each factory method a unique signature. You can overload factory methods in exactly the same way that you overload instance methods. For example, the CheckingAccount subclass provides two versions of the factory method createCheckingAccount: one that initializes the account to have a default balance of zero, and one that allows the opening balance to be passed in. Clients can invoke either createCheckingAccount method by passing arguments that match the signature of the intended method.

If you define a data item with the same name in both the DATA DIVISION of a factory method and the DATA DIVISION of the FACTORY paragraph, a reference in the method to that data-name refers only to the method data item. The method DATA DIVISION takes precedence.

“Example: defining a factory (with methods)” on page 625

RELATED TASKS

“Structuring OO applications” on page 630

“Wrapping procedure-oriented COBOL programs” on page 630

“Instantiating COBOL classes” on page 615

“Defining a class instance method” on page 597

“Coding attribute (get and set) methods” on page 603

“Overloading an instance method” on page 602

“Hiding a factory or static method”

“Invoking factory or static methods” on page 624

“Using object-oriented COBOL and Java under IMS” on page 458

Hiding a factory or static method

A factory method defined in a subclass is said to *hide* an inherited COBOL or Java method that would otherwise be accessible in the subclass if the two methods have the same signature.

To hide a superclass factory method f1 in a COBOL subclass, define a factory method f1 in the subclass that has the same name and whose PROCEDURE DIVISION USING phrase (if any) has the same number and type of formal parameters as the

superclass method has. (If the superclass method is implemented in Java, you must code formal parameters that are interoperable with the data types of the corresponding Java parameters.) When a client invokes f1 using the subclass name, the subclass method rather than the superclass method is invoked.

The presence or absence of a method return value and the data type of the return value used in the PROCEDURE DIVISION RETURNING phrase (if any) must be identical in the subclass factory method and the hidden superclass method.

A factory method must not hide an instance method in a Java or COBOL superclass.

“Example: defining a factory (with methods)” on page 625

RELATED TASKS

“Coding interoperable data types in COBOL and Java” on page 638

“Overriding an instance method” on page 601

“Invoking methods (INVOKE)” on page 610

RELATED REFERENCES

The Java Language Specification (Inheritance, overriding, and hiding)

The procedure division header (*Enterprise COBOL Language Reference*)

Invoking factory or static methods

To invoke a COBOL factory method or Java static method in a COBOL method or client program, code the class-name as the first operand of the INVOKE statement.

For example, a client program could invoke one of the overloaded CheckingAccount factory methods called createCheckingAccount to create a checking account with account number 777777 and an opening balance of \$300 by coding this statement:

```
Invoke CheckingAccount "createCheckingAccount"  
  using by value 777777 300  
  returning aCheckingAccount
```

To invoke a factory method from within the same class in which you define the factory method, you also use the class-name as the first operand in the INVOKE statement.

Code the name of the method to be invoked either as a literal or as an identifier whose value at run time is the method-name. The method-name must be an alphanumeric or national literal or a category alphabetic, alphanumeric, or national data item, and is interpreted in a case-sensitive manner.

If an invoked method is not supported in the class that you name in the INVOKE statement, a severity-3 Language Environment condition is raised at run time unless you code the ON EXCEPTION phrase in the INVOKE statement.

The conformance requirements for passing arguments to a COBOL factory method or Java static method in the USING phrase, and receiving a return value in the RETURNING phrase, are the same as those for invoking instance methods.

“Example: defining a factory (with methods)” on page 625

RELATED TASKS

“Invoking methods (INVOKE)” on page 610

“Using national data (Unicode) in COBOL” on page 130
“Coding interoperable data types in COBOL and Java” on page 638

RELATED REFERENCES

INVOKE statement (*Enterprise COBOL Language Reference*)

Example: defining a factory (with methods)

The following example updates the previous examples to show the definition of factory data and methods.

These updates are shown:

- The Account class adds factory data and a parameterized factory method, createAccount, which allows an Account instance to be created using an account number that is passed in.
- The CheckingAccount subclass adds factory data and an overloaded parameterized factory method, createCheckingAccount. One implementation of createCheckingAccount initializes the account with a default balance of zero, and the other allows the opening balance to be passed in. Clients can invoke either method by passing arguments that match the signature of the required method.
- The TestAccounts client invokes the services provided by the factory methods of the Account and CheckingAccount classes, and instantiates the Java Check class.
- The output from the TestAccounts client program is shown.

(The previous examples were “Example: defining a method” on page 604, “Example: defining a client” on page 616, and “Example: defining a subclass (with methods)” on page 620.)

You can also find the complete source code for this example in the cobol/demo/oosample subdirectory in the z/OS UNIX file system. Typically the complete path for the source is /usr/lpp/cobol/demo/oosample. You can use the makefile there to compile and link the code.

Account class

```
cb1 dll,thread,pgmname(longmixed)
Identification Division.
Class-id. Account inherits Base.
Environment Division.
Configuration section.
Repository.
    Class Base is "java.lang.Object"
    Class Account is "Account".
*
Identification division.
Factory.
Data division.
Working-storage section.
01 NumberOfAccounts pic 9(6) value zero.
*
Procedure Division.
*
*   createAccount method to create a new Account
*   instance, then invoke the OBJECT paragraph's init
*   method on the instance to initialize its instance data:
Identification Division.
Method-id. "createAccount".
Data division.
Linkage section.
01 inAccountNumber pic S9(6) binary.
01 outAccount object reference Account.
```

```

*       Facilitate access to JNI services:
      Copy JNI.
      Procedure Division using by value inAccountNumber
        returning outAccount.
*       Establish addressability to JNI environment structure:
      Set address of JNIEnv to JNIEnvPtr
      Set address of JNINativeInterface to JNIEnv
      Invoke Account New returning outAccount
      Invoke outAccount "init" using by value inAccountNumber
      Add 1 to NumberOfAccounts.
      End method "createAccount".
*
      End Factory.
*
      Identification division.
      Object.
      Data division.
      Working-storage section.
      01 AccountNumber pic 9(6).
      01 AccountBalance pic S9(9) value zero.
*
      Procedure Division.
*
*       init method to initialize the account:
      Identification Division.
      Method-id. "init".
      Data division.
      Linkage section.
      01 inAccountNumber pic S9(9) binary.
      Procedure Division using by value inAccountNumber.
        Move inAccountNumber to AccountNumber.
      End method "init".
*
*       getBalance method to return the account balance:
      Identification Division.
      Method-id. "getBalance".
      Data division.
      Linkage section.
      01 outBalance pic S9(9) binary.
      Procedure Division returning outBalance.
        Move AccountBalance to outBalance.
      End method "getBalance".
*
*       credit method to deposit to the account:
      Identification Division.
      Method-id. "credit".
      Data division.
      Linkage section.
      01 inCredit pic S9(9) binary.
      Procedure Division using by value inCredit.
        Add inCredit to AccountBalance.
      End method "credit".
*
*       debit method to withdraw from the account:
      Identification Division.
      Method-id. "debit".
      Data division.
      Linkage section.
      01 inDebit pic S9(9) binary.
      Procedure Division using by value inDebit.
        Subtract inDebit from AccountBalance.
      End method "debit".
*
*       print method to display formatted account number and balance:
      Identification Division.
      Method-id. "print".
      Data division.

```

```

Local-storage section.
01 PrintableAccountNumber pic ZZZZZ999999.
01 PrintableAccountBalance pic $$$,$$$,$$9CR.
Procedure Division.
    Move AccountNumber to PrintableAccountNumber
    Move AccountBalance to PrintableAccountBalance
    Display " Account: " PrintableAccountNumber
    Display " Balance: " PrintableAccountBalance.
End method "print".
*
End Object.
*
End class Account.

```

CheckingAccount class (subclass of Account)

```

cbl dll,thread,pgmname(longmixed)
Identification Division.
Class-id. CheckingAccount inherits Account.
Environment Division.
Configuration section.
Repository.
    Class CheckingAccount is "CheckingAccount"
    Class Check          is "Check"
    Class Account        is "Account".
*
Identification division.
Factory.
Data division.
Working-storage section.
01 NumberOfCheckingAccounts pic 9(6) value zero.
*
Procedure Division.
*
*   createCheckingAccount overloaded method to create a new
*   CheckingAccount instance with a default balance, invoke
*   inherited instance method init to initialize the account
*   number, and increment factory data tally of checking accounts:
Identification Division.
Method-id. "createCheckingAccount".
Data division.
Linkage section.
01 inAccountNumber pic S9(6) binary.
01 outCheckingAccount object reference CheckingAccount.
*   Facilitate access to JNI services:
    Copy JNI.
Procedure Division using by value inAccountNumber
    returning outCheckingAccount.
*   Establish addressability to JNI environment structure:
    Set address of JNIEnv to JNIEnvPtr
    Set address of JNINativeInterface to JNIEnv
    Invoke CheckingAccount New returning outCheckingAccount
    Invoke outCheckingAccount "init"
        using by value inAccountNumber
    Add 1 to NumberOfCheckingAccounts.
End method "createCheckingAccount".
*
*   createCheckingAccount overloaded method to create a new
*   CheckingAccount instance, invoke inherited instance methods
*   init to initialize the account number and credit to set the
*   balance, and increment factory data tally of checking accounts:
Identification Division.
Method-id. "createCheckingAccount".
Data division.
Linkage section.
01 inAccountNumber pic S9(6) binary.
01 inInitialBalance pic S9(9) binary.
01 outCheckingAccount object reference CheckingAccount.

```

```

Copy JNI.
Procedure Division using by value inAccountNumber
                                inInitialBalance
    returning outCheckingAccount.
Set address of JNIEnv to JNIEnvPtr
Set address of JNINativeInterface to JNIEnv
Invoke CheckingAccount New returning outCheckingAccount
Invoke outCheckingAccount "init"
    using by value inAccountNumber
Invoke outCheckingAccount "credit"
    using by value inInitialBalance
Add 1 to NumberOfCheckingAccounts.
End method "createCheckingAccount".
*
End Factory.
*
Identification division.
Object.
Data division.
Working-storage section.
01 CheckFee pic S9(9) value 1.
Procedure Division.
*
*   processCheck method to get the check amount and payee,
*   add the check fee, and invoke inherited methods debit
*   to debit the payer and credit to credit the payee:
Identification Division.
Method-id. "processCheck".
Data division.
Local-storage section.
01 amount pic S9(9) binary.
01 payee usage object reference Account.
Linkage section.
01 aCheck usage object reference Check.
Procedure Division using by value aCheck.
    Invoke aCheck "getAmount" returning amount
    Invoke aCheck "getPayee" returning payee
    Invoke payee "credit" using by value amount
    Add checkFee to amount
    Invoke self "debit" using by value amount.
End method "processCheck".
*
*   print method override to display account status:
Identification Division.
Method-id. "print".
Data division.
Local-storage section.
01 printableFee pic $$,$$$,$$9.
Procedure Division.
    Invoke super "print"
    Move CheckFee to printableFee
    Display " Check fee: " printableFee.
End method "print".
*
End Object.
*
End class CheckingAccount.

```

Check class

```

/**
 * A Java class for check information
 */
public class Check {
    private CheckingAccount payer;
    private Account        payee;
    private int             amount;

```

```

public Check(CheckingAccount inPayer, Account inPayee, int inAmount) {
    payer=inPayer;
    payee=inPayee;
    amount=inAmount;
}

public int getAmount() {
    return amount;
}

public Account getPayee() {
    return payee;
}
}

```

TestAccounts client program

```

cbl dll,thread,pgmname(longmixed)
Identification division.
Program-id. "TestAccounts" recursive.
Environment division.
Configuration section.
Repository.
    Class Account          is "Account"
    Class CheckingAccount is "CheckingAccount"
    Class Check           is "Check".
Data Division.
* Working data is declared in Local-storage
* so that each thread has its own copy:
Local-storage section.
01 anAccount          usage object reference Account.
01 aCheckingAccount  usage object reference CheckingAccount.
01 aCheck            usage object reference Check.
01 payee             usage object reference Account.
*
Procedure division.
Test-Account-section.
    Display "Test Account class"
* Create account 123456 with 0 balance:
    Invoke Account "createAccount"
        using by value 123456
        returning anAccount
* Deposit 500 to the account:
    Invoke anAccount "credit" using by value 500
    Invoke anAccount "print"
    Display space
*
    Display "Test CheckingAccount class"
* Create checking account 777777 with balance of 300:
    Invoke CheckingAccount "createCheckingAccount"
        using by value 777777 300
        returning aCheckingAccount
* Set account 123456 as the payee:
    Set payee to anAccount
* Initialize check for 125 to be paid by account 777777 to payee:
    Invoke Check New
        using by value aCheckingAccount, payee, 125
        returning aCheck
* Debit the payer, and credit the payee:
    Invoke aCheckingAccount "processCheck"
        using by value aCheck
    Invoke aCheckingAccount "print"
    Invoke anAccount "print"
*
    Stop Run.
End program "TestAccounts".

```

Output produced by the TestAccounts client program

```
Test Account class
Account:    123456
Balance:    $500
```

```
Test CheckingAccount class
Account:    777777
Balance:    $174
Check fee:  $1
Account:    123456
Balance:    $625
```

RELATED TASKS

“Creating and initializing instances of classes” on page 614
“Defining a factory method” on page 622
“Invoking factory or static methods” on page 624
Chapter 16, “Compiling, linking, and running OO applications,” on page 291

Wrapping procedure-oriented COBOL programs

A *wrapper* is a class that provides an interface between object-oriented code and procedure-oriented code. Factory methods provide a convenient means for writing wrappers for existing procedural COBOL code to make it accessible from Java programs.

To wrap COBOL code, do these steps:

1. Create a simple COBOL class that contains a FACTORY paragraph.
2. In the FACTORY paragraph, code a factory method that uses a CALL statement to call the procedural program.

A Java program can invoke the factory method by using a static method invocation expression, thus invoking the COBOL procedural program.

RELATED TASKS

“Defining a class” on page 592
“Defining a factory section” on page 621
“Defining a factory method” on page 622

Structuring OO applications

You can structure applications that use object-oriented COBOL syntax in one of three ways.

An OO application can begin with:

- A COBOL program, which can have any name.
Under z/OS UNIX, you can run the application by specifying the name of the linked module (which should match the program name) at the command prompt. You can also bind the program as a module in a PDSE and run it in JCL using the EXEC PGM statement.
- A Java class definition that contains a method called `main`. Declare `main` as `public`, `static`, and `void`, with a single parameter of type `String[]`.
You can run the application with the `java` command, specifying the name of the class that contains `main`, and zero or more strings as command-line arguments.
- A COBOL class definition that contains a factory method called `main`. Declare `main` with no RETURNING phrase and a single USING parameter, an object reference

to a class that is an array with elements of type `java.lang.String`. (Thus `main` is in effect `public`, `static`, and `void`, with a single parameter of type `String[]`.)

You can run the application with the `java` command, specifying the name of the class that contains `main`, and zero or more strings as command-line arguments.

Structure an OO application this way if you want to:

- Run the application by using the `java` command.
- Run the application in an environment where applications must start with the `main` method of a Java class (such as a Java dependent region).
- Follow standard Java programming practice.

“Examples: COBOL applications that run using the `java` command”

RELATED TASKS

Chapter 16, “Compiling, linking, and running OO applications,” on page 291

“Defining a factory method” on page 622

“Declaring arrays and strings for Java” on page 639

Chapter 22, “Developing COBOL programs for IMS,” on page 453

Examples: COBOL applications that run using the `java` command

The following examples show COBOL class definitions that contain a factory method called `main`.

In each case, `main` has no `RETURNING` phrase and has a single `USING` parameter, an object reference to a class that is an array with elements of type `java.lang.String`. You can run these applications by using the `java` command.

Displaying a message

```
cb1 dll,thread
Identification Division.
Class-id. CBLmain inherits Base.
Environment Division.
Configuration section.
Repository.
    Class Base is "java.lang.Object"
    Class stringArray is "jobjectArray:java.lang.String"
    Class CBLmain is "CBLmain".
*
Identification Division.
Factory.
    Procedure division.
*
    Identification Division.
    Method-id. "main".
    Data division.
    Linkage section.
    01 SA usage object reference stringArray.
    Procedure division using by value SA.
        Display " >> COBOL main method entered"
        .
    End method "main".
End factory.
End class CBLmain.
```

Echoing the input strings

```
cb1 dll,thread,pgmname(longmixed),ssrange
Identification Division.
Class-id. Echo inherits Base.
Environment Division.
```

```

Configuration section.
Repository.
  Class Base is "java.lang.Object"
  Class stringArray is "jobjectArray:java.lang.String"
  Class jstring is "java.lang.String"
  Class Echo is "Echo".
*
Identification Division.
Factory.
  Procedure division.
*
  Identification Division.
  Method-id. "main".
  Data division.
  Local-storage section.
  01 SALen      pic s9(9) binary.
  01 I          pic s9(9) binary.
  01 SAelement  object reference jstring.
  01 SAelementlen pic s9(9) binary.
  01 Sbuffer    pic X(65535).
  01 P          pointer.
  Linkage section.
  01 SA        object reference stringArray.
  Copy "JNI.cpy" suppress.
  Procedure division using by value SA.
  Set address of JNIEnv to JNIEnvPtr
  Set address of JNIInterface to JNIEnv
  Call GetArrayLength using by value JNIEnvPtr SA
  returning SALen
  Display "Input string array length: " SALen
  Display "Input strings:"
  Perform varying I from 0 by 1 until I = SALen
  Call GetObjectArrayElement
  using by value JNIEnvPtr SA I
  returning SAelement
  Call "GetStringPlatformLength"
  using by value JNIEnvPtr
  SAelement
  address of SAelementlen
  0
  Call "GetStringPlatform"
  using by value JNIEnvPtr
  SAelement
  address of Sbuffer
  length of Sbuffer
  0
  Display Sbuffer(1:SAelementlen)
  End-perform
  .
  End method "main".
  End factory.
  End class Echo.

```

RELATED TASKS

Chapter 16, "Compiling, linking, and running OO applications," on page 291

"Defining a factory method" on page 622

Chapter 31, "Communicating with Java methods," on page 633

Chapter 31. Communicating with Java methods

To achieve interlanguage interoperability with Java, you need to follow certain rules and guidelines for using services in the Java Native Interface (JNI), coding data types, and compiling COBOL programs.

You can invoke methods that are written in Java from COBOL programs, and you can invoke methods that are written in COBOL from Java programs. You need to code COBOL object-oriented language for basic Java object capabilities. For additional Java capabilities, you can call JNI services.

Because Java programs might be multithreaded and use asynchronous signals, compile COBOL programs with the `THREAD` option.

“Example: J2EE client written in COBOL” on page 644

RELATED TASKS

Chapter 16, “Compiling, linking, and running OO applications,” on page 291

“Accessing JNI services”

“Sharing data with Java” on page 637

Chapter 30, “Writing object-oriented programs,” on page 589

Chapter 27, “Preparing COBOL programs for multithreading,” on page 517

RELATED REFERENCES

JDK 5.0 Documentation

Accessing JNI services

The Java Native Interface (JNI) provides many callable services that you can use when you develop applications that mix COBOL and Java. To facilitate access to these services, copy `JNI.cpy` into the `LINKAGE SECTION` of your COBOL program.

The `JNI.cpy` copybook contains these definitions:

- COBOL data definitions that correspond to the Java JNI types
- `JNINativeInterface`, the JNI environment structure that contains function pointers for accessing the callable service functions

You obtain the JNI environment structure by two levels of indirection from the JNI environment pointer, as the following illustration shows:

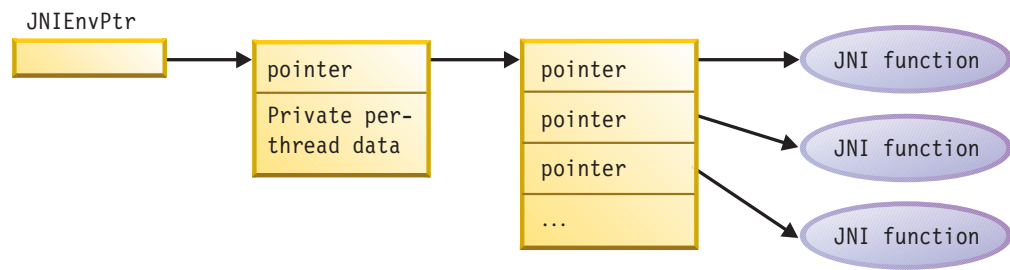

Use the special register `JNIEnvPtr` to reference the JNI environment pointer to obtain the address for the JNI environment structure. `JNIEnvPtr` is implicitly

defined as USAGE POINTER; do not use it as a receiving data item. Before you reference the contents of the JNI environment structure, you must code the following statements to establish its addressability:

```
Linkage section.  
COPY JNI  
.  
.  
.  
Procedure division.  
    Set address of JNIEnv to JNIEnvPtr  
    Set address of JNINativeInterface to JNIEnv  
    .  
    .  
    .
```

The code above sets the addresses of the following items:

- JNIEnv, a pointer data item that JNI.cpy provides. JNIEnvPtr is the COBOL special register that contains the environment pointer.
- JNINativeInterface, the COBOL group structure that JNI.cpy contains. This structure maps the JNI environment structure, which contains an array of function pointers for the JNI callable services.

After you code the statements above, you can access the JNI callable services with CALL statements that reference the function pointers. You can pass the JNIEnvPtr special register as the first argument to the services that require the environment pointer, as shown in the following example:

```
01 InputArrayObj usage object reference jlongArray.  
01 ArrayLen pic S9(9) comp-5.  
.  
.  
.  
    Call GetArrayLength using by value JNIEnvPtr InputArrayObj  
        returning ArrayLen
```

Important: Pass all arguments to the JNI callable services by value.

Some JNI callable services require a Java class-object reference as an argument. To obtain a reference to the class object that is associated with a class, use one of the following JNI callable services:

- GetObjectClass
- FindClass

Restriction: The JNI environment pointer is thread specific. Do not pass it from one thread to another.

RELATED TASKS

“Managing local and global references” on page 636

“Handling Java exceptions”

“Coding interoperable data types in COBOL and Java” on page 638

“Defining a client” on page 606

RELATED REFERENCES

Appendix E, “JNI.cpy copybook,” on page 731

The Java Native Interface

Handling Java exceptions

Use JNI services to throw and catch Java exceptions.

Throwing an exception: Use one of the following services to throw a Java exception from a COBOL method:

- Throw

- ThrowNew

You must make the thrown object an instance of a subclass of `java.lang.Throwable`.

The Java virtual machine (JVM) does not recognize and process the thrown exception until the method that contains the call has completed and returned to the JVM.

Catching an exception: After you invoke a method that might have thrown a Java exception, you can do these steps:

1. Test whether an exception occurred.
2. If an exception occurred, process the exception.
3. Clear the exception, if clearing is appropriate.

Use the following JNI services:

- ExceptionOccurred
- ExceptionCheck
- ExceptionDescribe
- ExceptionClear

To do error analysis, use the methods supported by the exception object that is returned. This object is an instance of the `java.lang.Throwable` class.

“Example: handling Java exceptions”

Example: handling Java exceptions

The following example shows the use of JNI services for catching an exception from Java and the use of the `printStackTrace` method of `java.lang.Throwable` for error analysis.

```
Repository.
  Class JavaException is "java.lang.Exception".
. . .
Local-storage section.
01 ex usage object reference JavaException.
Linkage section.
COPY "JNI.cpy".
. . .
Procedure division.
  Set address of JNIEnv to JNIEnvPtr
  Set address of JNINativeInterface to JNIEnv
. . .
  Invoke anObj "someMethod"
  Perform ErrorCheck
. . .
ErrorCheck.
  Call ExceptionOccurred
    using by value JNIEnvPtr
    returning ex
  If ex not = null then
    Call ExceptionClear using by value JNIEnvPtr
    Display "Caught an unexpected exception"
    Invoke ex "printStackTrace"
  Stop run
End-if
```

Managing local and global references

The Java virtual machine tracks the object references that you use in native methods, such as COBOL methods. This tracking ensures that the objects are not prematurely released during garbage collection.

There are two classes of such references:

Local references

Local references are valid only while the method that you invoke runs. Automatic freeing of the local references occurs after the native method returns.

Global references

Global references remain valid until you explicitly delete them. You can create global references from local references by using the JNI service `NewGlobalRef`.

The following object references are always local:

- Object references that are received as method parameters
- Object references that are returned as the method RETURNING value from a method invocation
- Object references that are returned by a call to a JNI function
- Object references that you create by using the INVOKE . . . NEW statement

You can pass either a local reference or a global reference as an object reference argument to a JNI service.

You can code methods to return either local or global references as RETURNING values. However, in either case, the reference that is received by the invoking program is a local reference.

You can pass either local or global references as USING arguments in a method invocation. However, in either case, the reference that is received by the invoked method is a local reference.

Local references are valid only in the thread in which you create them. Do not pass them from one thread to another.

RELATED TASKS

“Accessing JNI services” on page 633

“Deleting, saving, and freeing local references”

Deleting, saving, and freeing local references

You can manually delete local references at any point within a method. Save local references only in object references that you define in the LOCAL-STORAGE SECTION of a method.

Use a SET statement to convert a local reference to a global reference if you want to save a reference in any of these data items:

- An object instance variable
- A factory variable
- A data item in the WORKING-STORAGE SECTION of a method

Otherwise, an error occurs. These storage areas persist when a method returns; therefore a local reference is no longer valid.

In most cases you can rely on the automatic freeing of local references that occurs when a method returns. However, in some cases you should explicitly free a local reference within a method by using the JNI service `DeleteLocalRef`. Here are two situations where explicit freeing is appropriate:

- In a method you access a large object, thereby creating a local reference to the object. After extensive computations, the method returns. Free the large object if you do not need it for the additional computations, because the local reference prevents the object from being released during garbage collection.
- You create a large number of local references in a method, but do not use all of them at the same time. Because the Java virtual machine requires space to keep track of each local reference, you should free those that you no longer need. Freeing the local references helps prevent the system from running out of memory.

For example, in a COBOL method you loop through a large array of objects, retrieve the elements as local references, and operate on one element at each iteration. You can free the local reference to the array element after each iteration.

Use the following callable services to manage local references and global references.

Table 82. JNI services for local and global references

Service	Input arguments	Return value	Purpose
<code>NewGlobalRef</code>	<ul style="list-style-type: none"> • The JNI environment pointer • A local or global object reference 	The global reference, or NULL if the system is out of memory	To create a new global reference to the object that the input object reference refers to
<code>DeleteGlobalRef</code>	<ul style="list-style-type: none"> • The JNI environment pointer • A global object reference 	None	To delete a global reference to the object that the input object reference refers to
<code>DeleteLocalRef</code>	<ul style="list-style-type: none"> • The JNI environment pointer • A local object reference 	None	To delete a local reference to the object that the input object reference refers to

RELATED TASKS

“Accessing JNI services” on page 633

Java access controls

The Java access modifiers `protected` and `private` are not enforced when you use the Java Native Interface. Therefore a COBOL program could invoke a `protected` or `private` Java method that is not invocable from a Java client. This usage is not recommended.

Sharing data with Java

You can share the COBOL data types that have Java equivalents. (Some COBOL data types have Java equivalents, but others do not.)

Share data items with Java in these ways:

- Pass them as arguments in the `USING` phrase of an `INVOKE` statement.
- Receive them as parameters in the `USING` phrase from a Java method.

- Receive them as the RETURNING value in an INVOKE statement.
- Return them as the value in the RETURNING phrase of the PROCEDURE DIVISION header in a COBOL method.

To pass or receive arrays and strings, declare them as object references:

- Declare an array as an object reference that contains an instance of one of the special array classes.
- Declare a string as an object reference that contains an instance of the jstring class.

RELATED TASKS

“Coding interoperable data types in COBOL and Java”

“Declaring arrays and strings for Java” on page 639

“Manipulating Java arrays” on page 640

“Manipulating Java strings” on page 642

“Invoking methods (INVOKE)” on page 610

Chapter 25, “Sharing data,” on page 491

Coding interoperable data types in COBOL and Java

Your COBOL program can use only certain data types when communicating with Java.

Table 83. Interoperable data types in COBOL and Java

Primitive Java data type	Corresponding COBOL data type
boolean ¹	PIC X followed by exactly two condition-names of this form: <i>level-number data-name</i> PIC X. 88 <i>data-name-false</i> value X'00'. 88 <i>data-name-true</i> value X'01' through X'FF'.
byte ¹	Single-byte alphanumeric: PIC X or PIC A
short	USAGE BINARY, COMP, COMP-4, or COMP-5, with PICTURE clause of the form S9(<i>n</i>), where 1<= <i>n</i> <=4
int	USAGE BINARY, COMP, COMP-4, or COMP-5, with PICTURE clause of the form S9(<i>n</i>), where 5<= <i>n</i> <=9
long	USAGE BINARY, COMP, COMP-4, or COMP-5, with PICTURE clause of the form S9(<i>n</i>), where 10<= <i>n</i> <=18
float ²	USAGE COMP-1
double ²	USAGE COMP-2
char	Single-character elementary national: PIC N USAGE NATIONAL. (Cannot be a national group.)
class types (object references)	USAGE OBJECT REFERENCE <i>class-name</i>
<ol style="list-style-type: none"> 1. You must distinguish boolean from byte, because they each correspond to PIC X. PIC X is interpreted as boolean only if you define an argument or a parameter with the two condition-names as shown. Otherwise, a PIC X data item is interpreted as the Java byte type. 2. Java floating-point data is formatted according to the <i>IEEE Standard for Binary Floating Point Arithmetic</i>. Enterprise COBOL, however, uses hexadecimal floating-point representation. When you pass floating-point arguments by using an INVOKE statement, or you receive floating-point data from a Java method, the arguments and data are automatically converted as needed. 	

RELATED TASKS

“Using national data (Unicode) in COBOL” on page 130

Declaring arrays and strings for Java

When you communicate with Java, declare arrays by using the special array classes, and declare strings by using `jstring`. Code the COBOL data types shown in the table below.

Table 84. Interoperable arrays and strings in COBOL and Java

Java data type	Corresponding COBOL data type
<code>boolean[]</code>	object reference <code>jbooleanArray</code>
<code>byte[]</code>	object reference <code>jbyteArray</code>
<code>short[]</code>	object reference <code>jshortArray</code>
<code>int[]</code>	object reference <code>jintArray</code>
<code>long[]</code>	object reference <code>jlongArray</code>
<code>char[]</code>	object reference <code>jcharArray</code>
<code>Object[]</code>	object reference <code>jobjectArray</code>
<code>String</code>	object reference <code>jstring</code>

To use one of these classes for interoperability with Java, you must code an entry in the REPOSITORY paragraph. For example:

Configuration section.

Repository.

```
Class jbooleanArray is "jbooleanArray".
```

The REPOSITORY paragraph entry for an object array type must specify an external class-name in one of these forms:

```
"jobjectArray"
```

```
"jobjectArray:external-classname-2"
```

In the first case, the REPOSITORY entry specifies an array class in which the elements of the array are objects of type `java.lang.Object`. In the second case, the REPOSITORY entry specifies an array class in which the elements of the array are objects of type `external-classname-2`. Code a colon as the separator between the specification of the `jobjectArray` type and the external class-name of the array elements.

The following example shows both cases. In the example, `oa` defines an array of elements that are objects of type `java.lang.Object`. `aDepartment` defines an array of elements that are objects of type `com.acme.Employee`.

Environment Division.

Configuration Section.

Repository.

```
Class jobjectArray is "jobjectArray"
```

```
Class Employee is "com.acme.Employee"
```

```
Class Department is "jobjectArray:com.acme.Employee".
```

. . .

Linkage section.

```
01 oa usage object reference jobjectArray.
```

```
01 aDepartment usage object reference Department.
```

. . .

Procedure division using by value aDepartment.

. . .

“Examples: COBOL applications that run using the `java` command” on page 631

The following Java array types are currently not supported for interoperation with COBOL programs.

Table 85. Noninteroperable array types in COBOL and Java

Java data type	Corresponding COBOL data type
float[]	object reference jfloatArray
double[]	object reference jdoubleArray

RELATED TASKS

“REPOSITORY paragraph for defining a class” on page 594

Manipulating Java arrays

To represent an array in a COBOL program, code a group item that contains a single elementary item that is of the data type that corresponds to the Java type of the array. Specify an OCCURS or OCCURS DEPENDING ON clause that is appropriate for the array.

For example, the following code specifies a structure to receive 500 or fewer integer values from a jlongArray object:

```
01 jlongArray.
   02 X pic S9(10) comp-5 occurs 1 to 500 times depending on N.
```

To operate on objects of the special Java-array classes, call the services that the JNI provides. You can use services to access and set individual elements of an array and for the following purposes, using the services cited:

Table 86. JNI array services

Service	Input arguments	Return value	Purpose
GetArrayLength	<ul style="list-style-type: none"> The JNI environment pointer The array object reference 	The array length as a binary fullword integer	To get the number of elements in a Java array object
NewBooleanArray, NewByteArray, NewCharArray, NewShortArray, NewIntArray, NewLongArray	<ul style="list-style-type: none"> The JNI environment pointer The number of elements in the array, as a binary fullword integer 	The array object reference, or NULL if the array cannot be constructed	To create a new Java array object
GetBooleanArrayElements, GetByteArrayElements, GetCharArrayElements, GetShortArrayElements, GetIntArrayElements, GetLongArrayElements	<ul style="list-style-type: none"> The JNI environment pointer The array object reference A pointer to a boolean item. If the pointer is not null, the boolean item is set to true if a copy of the array elements was made. If a copy was made, the corresponding ReleasexxxArrayElements service must be called if changes are to be written back to the array object. 	A pointer to the storage buffer	To extract the array elements from a Java array into a storage buffer. The services return a pointer to the storage buffer, which you can use as the address of a COBOL group data item defined in the LINKAGE SECTION.

Table 86. JNI array services (continued)

Service	Input arguments	Return value	Purpose
ReleaseBooleanArrayElements, ReleaseByteArrayElements, ReleaseCharArrayElements, ReleaseShortArrayElements, ReleaseIntArrayElements, ReleaseLongArrayElements	<ul style="list-style-type: none"> • The JNI environment pointer • The array object reference • A pointer to the storage buffer • The release mode, as a binary fullword integer. See Java JNI documentation for details. (Recommendation: Specify 0 to copy back the array content and free the storage buffer.) 	None; the storage for the array is released.	To release the storage buffer that contains elements that have been extracted from a Java array, and conditionally map the updated array values back into the array object
NewObjectArray	<ul style="list-style-type: none"> • The JNI environment pointer • The number of elements in the array, as a binary fullword integer • An object reference for the array element class • An object reference for the initial element value. All array elements are set to this value. 	The array object reference, or NULL if the array cannot be constructed ¹	To create a new Java object array
GetObjectArrayElement	<ul style="list-style-type: none"> • The JNI environment pointer • The array object reference • An array element index, as a binary fullword integer using origin zero 	An object reference ²	To return the element at a given index within an object array
SetObjectArrayElement	<ul style="list-style-type: none"> • The JNI environment pointer • The array object reference • The array element index, as a binary fullword integer using origin zero • The object reference for the new value 	None ³	To set an element within an object array
<ol style="list-style-type: none"> 1. NewObjectArray throws an exception if the system runs out of memory. 2. GetObjectArrayElement throws an exception if the index is not valid. 3. SetObjectArrayElement throws an exception if the index is not valid or if the new value is not a subclass of the element class of the array. 			

“Examples: COBOL applications that run using the java command” on page 631
 “Example: processing a Java integer array”

RELATED TASKS

“Coding interoperable data types in COBOL and Java” on page 638
 “Declaring arrays and strings for Java” on page 639
 “Accessing JNI services” on page 633

Example: processing a Java integer array

The following example shows the use of the Java-array classes and JNI services to process a Java integer array in COBOL.

```

cbl thread,dll
Identification division.
Class-id. 00ARRAY inherits Base.
    
```

```

Environment division.
Configuration section.
Repository.
    Class Base is "java.lang.Object"
    Class jintArray is "jintArray".
Identification division.
Object.
Procedure division.
    Identification division.
    Method-id. "ProcessArray".
    Data Division.
    Local-storage section.
    01 intArrayPtr pointer.
    01 intArrayLen pic S9(9) comp-5.
    Linkage section.
        COPY JNI.
    01 inIntArrayObj usage object reference jintArray.
    01 intArrayGroup.
        02 X pic S9(9) comp-5
            occurs 1 to 1000 times depending on intArrayLen.
    Procedure division using by value inIntArrayObj.
        Set address of JNIEnv to JNIEnvPtr
        Set address of JNINativeInterface to JNIEnv

        Call GetArrayLength
            using by value JNIEnvPtr inIntArrayObj
            returning intArrayLen
        Call GetIntArrayElements
            using by value JNIEnvPtr inIntArrayObj 0
            returning IntArrayPtr
        Set address of intArrayGroup to intArrayPtr

* . . . process the array elements X(I) . . .

        Call ReleaseIntArrayElements
            using by value JNIEnvPtr inIntArrayObj intArrayPtr 0.
    End method "ProcessArray".
End Object.
End class OOARRAY.

```

Manipulating Java strings

COBOL represents Java String data in Unicode. To represent a Java String in a COBOL program, declare the string as an object reference of the `jstring` class. Then use JNI services to set or extract COBOL alphanumeric or national (Unicode) data from the object.

Services for Unicode: Use the following standard services to convert between `jstring` object references and COBOL `USAGE NATIONAL` data items. Use these services for applications that you intend to be portable between the workstation and the mainframe. Access these services by using function pointers in the `JNINativeInterface` environment structure.

Table 87. Services that convert between jstring references and national data

Service	Input arguments	Return value
<code>NewString</code> ¹	<ul style="list-style-type: none"> The JNI environment pointer A pointer to a Unicode string, such as a COBOL national data item The number of characters in the string; binary fullword 	<code>jstring</code> object reference

Table 87. Services that convert between jstring references and national data (continued)

Service	Input arguments	Return value
GetStringLength	<ul style="list-style-type: none"> The JNI environment pointer A jstring object reference 	The number of Unicode characters in the jstring object reference; binary fullword
GetStringChars ¹	<ul style="list-style-type: none"> The JNI environment pointer A jstring object reference A pointer to a boolean data item, or NULL 	<ul style="list-style-type: none"> A pointer to the array of Unicode characters extracted from the jstring object, or NULL if the operation fails. The pointer is valid until it is released with ReleaseStringChars. If the pointer to the boolean data item is not null, the boolean value is set to true if a copy is made of the string and to false if no copy is made.
ReleaseStringChars	<ul style="list-style-type: none"> The JNI environment pointer A jstring object reference A pointer to the array of Unicode characters that was returned from GetStringChars 	None; the storage for the array is released.

1. This service throws an exception if the system runs out of memory.

Services for EBCDIC: Use the following z/OS services, an extension of the JNI, to convert between jstring object references and COBOL alphanumeric data (PIC X(n)).

Table 88. Services that convert between jstring references and alphanumeric data

Service	Input arguments	Return value
NewStringPlatform	<ul style="list-style-type: none"> The JNI environment pointer Pointer to the null-terminated EBCDIC character string that you want to convert to a jstring object Pointer to the jstring object reference in which you want the result Pointer to the Java encoding name for the string, represented as a null-terminated EBCDIC character string¹ 	Return code as a binary fullword integer: <ul style="list-style-type: none"> 0 Success. -1 Malformed input or illegal input character. -2 Unsupported encoding; the jstring object reference pointer is set to NULL.
GetStringPlatformLength	<ul style="list-style-type: none"> The JNI environment pointer jstring object reference for which you want the length Pointer to a binary fullword integer for the result Pointer to the Java encoding name for the string, represented as a null-terminated EBCDIC character string¹ 	Return code as a binary fullword integer: <ul style="list-style-type: none"> 0 Success. -1 Malformed input or illegal input character. -2 Unsupported encoding; the jstring object reference pointer is set to NULL. Returns, in the third argument, the needed length in bytes of the output buffer to hold the converted Java string, including the terminating null byte referenced by the second argument.

Table 88. Services that convert between jstring references and alphanumeric data (continued)

Service	Input arguments	Return value
GetStringPlatform	<ul style="list-style-type: none"> The JNI environment pointer jstring object reference that you want to convert to a null-terminated string Pointer to the output buffer in which you want the converted string Length of the output buffer as a binary fullword integer Pointer to the Java encoding name for the string, represented as a null-terminated EBCDIC character string¹ 	Return code as a binary fullword integer: 0 Success. -1 Malformed input or illegal input character. -2 Unsupported encoding; the output string is set to a null string. -3 Conversion buffer is full.
1. If the pointer is NULL, the encoding from the Java file.encoding property is used.		

These EBCDIC services are packaged as a DLL that is part of your IBM Java Software Development Kit. For details about the services, see `jni_convert.h` in the IBM Java Software Development Kit.

Use CALL *literal* statements to call the services. The calls are resolved through the `libjvm.x` DLL side file, which you must include in the link step of any COBOL program that uses object-oriented language.

For example, the following code creates a Java String object from the EBCDIC string 'MyConverter'. (This code fragment is from the J2EE client program, which is shown in full in "Example: J2EE client written in COBOL.")

```

Move z"MyConverter" to stringBuffer
Call "NewStringPlatform"
  using by value JNIEnvPtr
                address of stringBuffer
                address of jstring1
                0
  returning rc
  
```

If the EBCDIC services are the only JNI services that you call from a COBOL program, you do not need to copy the `JNI.cpy` copybook. You also do not need to establish addressability with the JNI environment pointer.

Services for UTF-8: The Java Native Interface also provides services for conversion between jstring object references and UTF-8 strings. These services are not recommended for use in COBOL programs due to the difficulty in handling UTF-8 character strings on the z/OS platform.

RELATED TASKS

"Accessing JNI services" on page 633

"Coding interoperable data types in COBOL and Java" on page 638

"Declaring arrays and strings for Java" on page 639

"Using national data (Unicode) in COBOL" on page 130

Chapter 16, "Compiling, linking, and running OO applications," on page 291

Example: J2EE client written in COBOL

The following example shows a COBOL client program that can access enterprise beans that run on a J2EE-compliant EJB server.

The COBOL client is equivalent to the J2EE client program in the Getting Started section of the *Java 2 Enterprise Edition Developer's Guide*. For your convenience in comparing implementations, the second example shows the equivalent Java client from the guide. (The enterprise bean is the Java implementation of the simple currency-converter enterprise bean, and is in the same guide.)

You can find an alternate version of the Java enterprise bean and client code in *The Java EE 5 Tutorial*, referenced below.

COBOL client (ConverterClient.cbl)

```

Process pgmname(longmixed),dll,thread
*****
* Demo J2EE client written in COBOL. *
* *
* Based on the sample J2EE client written in Java, which is *
* given in the "Getting Started" chapter of "The Java(TM) 2 *
* Enterprise Edition Developer's Guide." *
* *
* The client: *
* - Locates the home interface of a session enterprise bean *
* (a simple currency converter bean) *
* - Creates an enterprise bean instance *
* - Invokes a business method (currency conversion) *
*****
Identification division.
Program-id. "ConverterClient" is recursive.
Environment Division.
Configuration section.
Repository.
    Class InitialContext is "javax.naming.InitialContext"
    Class PortableRemoteObject
        is "javax.rmi.PortableRemoteObject"
    Class JavaObject is "java.lang.Object"
    Class JavaClass is "java.lang.Class"
    Class JavaException is "java.lang.Exception"
    Class jstring is "jstring"
    Class Converter is "Converter"
    Class ConverterHome is "ConverterHome".
Data division.
Working-storage section.
01 initialCtx object reference InitialContext.
01 obj object reference JavaObject.
01 classObj object reference JavaClass.
01 ex object reference JavaException.
01 currencyConverter object reference Converter.
01 home object reference ConverterHome.
01 homeObject redefines home object reference JavaObject.
01 jstring1 object reference jstring.
01 stringBuffer pic X(500) usage display.
01 len pic s9(9) comp-5.
01 rc pic s9(9) comp-5.
01 amount comp-2.
Linkage section.
    Copy JNI.
Procedure division.
    Set address of JNIenv to JNIenvPtr
    Set address of JNINativeInterface to JNIenv

*****
* Create JNDI naming context. *
*****
    Invoke InitialContext New returning initialCtx
    Perform JavaExceptionCheck

```

```

*****
* Create a jstring object for the string "MyConverter" for use *
* as argument to the lookup method. *
*****
    Move z"MyConverter" to stringBuffer
    Call "NewStringPlatform"
        using by value JNIEnvPtr
            address of stringBuffer
            address of jstring1
            0
    returning rc
    If rc not = zero then
        Display "Error occurred creating jstring object"
        Stop run
    End-if

*****
* Use the lookup method to obtain a reference to the home *
* object bound to the name "MyConverter". (This is the JNDI *
* name specified when deploying the J2EE application.) *
*****
    Invoke initialCtx "lookup" using by value jstring1
    returning obj
    Perform JavaExceptionCheck

*****
* Narrow the home object to be of type ConverterHome. *
* First obtain class object for the ConverterHome class, by *
* passing the null-terminated ASCII string "ConverterHome" to *
* the FindClass API. Then use this class object as the *
* argument to the static method "narrow". *
*****
    Move z"ConverterHome" to stringBuffer
    Call "_etoa"
        using by value address of stringBuffer
        returning len
    If len = -1 then
        Display "Error occurred on ASCII conversion"
        Stop run
    End-if
    Call FindClass
        using by value JNIEnvPtr
            address of stringBuffer
        returning classObj
    If classObj = null
        Display "Error occurred locating ConverterHome class"
        Stop run
    End-if
    Invoke PortableRemoteObject "narrow"
        using by value obj
            classObj
        returning homeObject
    Perform JavaExceptionCheck

*****
* Create the ConverterEJB instance and obtain local object *
* reference for its remote interface *
*****
    Invoke home "create" returning currencyConverter
    Perform JavaExceptionCheck

*****
* Invoke business methods *
*****
    Invoke currencyConverter "dollarToYen"
        using by value +100.00E+0
        returning amount

```

```

Perform JavaExceptionCheck

Display amount

Invoke currencyConverter "yenToEuro"
    using by value +100.00E+0
    returning amount
Perform JavaExceptionCheck

Display amount

*****
* Remove the object and return.                                     *
*****
    Invoke currencyConverter "remove"
    Perform JavaExceptionCheck

Goback
.

*****
* Check for thrown Java exceptions                                 *
*****
JavaExceptionCheck.
    Call ExceptionOccurred using by value JNIEnvPtr
    returning ex
    If ex not = null then
        Call ExceptionClear using by value JNIEnvPtr
        Display "Caught an unexpected exception"
        Invoke ex "printStackTrace"
        Stop run
    End-if
.
End program "ConverterClient".

```

Java client (ConverterClient.java)

```

/*
 *
 * Copyright 2000 Sun Microsystems, Inc. All Rights Reserved.
 *
 * This software is the proprietary information of Sun Microsystems, Inc.
 * Use is subject to license terms.
 *
 */

import javax.naming.Context;
import javax.naming.InitialContext;
import javax.rmi.PortableRemoteObject;

import Converter;
import ConverterHome;

public class ConverterClient {

    public static void main(String[] args) {
        try {
            Context initial = new InitialContext();
            Object objref = initial.lookup("MyConverter");

            ConverterHome home =
                (ConverterHome)PortableRemoteObject.narrow(objref,
                                                            ConverterHome.class);

            Converter currencyConverter = home.create();

            double amount = currencyConverter.dollarToYen(100.00);

```

```
        System.out.println(String.valueOf(amount));
        amount = currencyConverter.yenToEuro(100.00);
        System.out.println(String.valueOf(amount));

        currencyConverter.remove();

    } catch (Exception ex) {
        System.err.println("Caught an unexpected exception!");
        ex.printStackTrace();
    }
}
}
```

RELATED TASKS

Chapter 16, "Compiling, linking, and running OO applications," on page 291

WebSphere for z/OS: Applications

Java 2 Enterprise Edition Developer's Guide (Getting Started)

The Java EE 5 Tutorial (Getting Started with Enterprise Beans)

Part 7. Specialized processing

Chapter 32. Interrupts and checkpoint/restart

When programs run for an extended period of time, interruptions might halt processing before the end of a job. The checkpoint/restart functions of z/OS let an interrupted program be restarted at the beginning of a job step or at a checkpoint that you have set.

Because the checkpoint/restart functions cause a lot of extra processing, use them only when you anticipate interruptions caused by machine malfunctions, input or output errors, or intentional operator intervention.

The checkpoint routine starts from the COBOL program object that contains your program. While your program is running, the checkpoint routine creates records at points that you have designated using the COBOL RERUN clause. A checkpoint record contains a snapshot of the information in the registers and main storage when the program reached the checkpoint.

The restart routine restarts an interrupted program. You can perform a restart at any time after the program was interrupted: either immediately (automatic restart), or later (deferred restart).

RELATED TASKS

“Setting checkpoints”

“Restarting programs” on page 654

“Resubmitting jobs for restart” on page 657

z/OS DFSMS: Checkpoint/Restart

RELATED REFERENCES

“DD statements for defining checkpoint data sets” on page 653

“Messages generated during checkpoint” on page 654

“Formats for requesting deferred restart” on page 656

Setting checkpoints

To set checkpoints, use job control statements and use the RERUN clause in the ENVIRONMENT DIVISION. Associate each RERUN clause with a particular COBOL file.

The RERUN clause indicates that a checkpoint record is to be written to a checkpoint data set whenever a specified number of records in the COBOL file have been processed or when END OF VOLUME is reached. You cannot use the RERUN clause with files that are defined with the EXTERNAL attribute.

You can write checkpoint records from several COBOL files to one checkpoint data set, but you must use a separate data set exclusively for checkpoint records. You cannot embed checkpoint records in one of your program data sets.

Restrictions: A checkpoint data set must have sequential organization. You cannot write checkpoints in VSAM data sets or in data sets that are allocated to extended-format QSAM data sets. Also, a checkpoint cannot be taken if any program in the run unit has an extended-format QSAM data set that is open.

Checkpoint records are written in the checkpoint data set defined by a DD statement. In the DD statement, you also choose the checkpoint method:

Single (store single checkpoints)

Only one checkpoint record exists at any given time. After the first checkpoint record is written, any succeeding checkpoint record overlays the previous one.

This method is acceptable for most programs. You save space in the checkpoint data set, and you can restart your program at the latest checkpoint.

Multiple (store multiple contiguous checkpoints)

Checkpoints are recorded and numbered sequentially. Each checkpoint is saved.

Use this method if you want to restart a program at a checkpoint other than the latest one taken.

You must use the multiple checkpoint method for complete compliance with the 85 COBOL Standard.

Checkpoints during sort operations have the following requirements:

- If checkpoints are to be taken during a sort operation, add a DD statement for SORTCKPT in the job control procedure for execution.
- You can take checkpoint records on ASCII-collated sorts, but the *system-name* that indicates the checkpoint data set must not specify an ASCII file.

RELATED TASKS

“Using checkpoint/restart with DFSORT” on page 236

“Designing checkpoints”

“Testing for a successful checkpoint”

RELATED REFERENCES

“DD statements for defining checkpoint data sets” on page 653

Designing checkpoints

Design your checkpoints at critical points in your program so that data can be easily reconstructed. Do not change the contents of files between the time of a checkpoint and the time of the restart.

In a program that uses disk files, design the program so that you can identify previously processed records. For example, consider a disk file that contains loan records that are periodically updated for interest due. If a checkpoint is taken, records are updated, and then the program is interrupted, you would want to test that the records that are updated after the last checkpoint are not updated again when the program is restarted. To do this, set up a date field in each record, and update the field each time the record is processed. Then, after the restart, test the field to determine whether the record was already processed.

For efficient repositioning of a print file, take checkpoints on the file only after printing the last line of a page.

Testing for a successful checkpoint

After each input or output statement that issues a checkpoint, the RETURN-CODE special register is updated with the return code from the checkpoint routine. Therefore, you can test whether the checkpoint was successful and decide whether conditions are right to allow a restart.

If the return code is greater than 4, an error has occurred in the checkpoint. Check the return code to prevent a restart that could cause incorrect output.

RELATED REFERENCES

z/OS DFSMS: Checkpoint/Restart (Return codes)

DD statements for defining checkpoint data sets

To define checkpoint data sets, use DD statements.

For tape:

```
//ddname DD DSNAME=data-set-name,  
//          [VOLUME=SER=volser,]UNIT=device-type,  
//          DISP=({NEW|MOD},PASS)
```

For direct-access devices:

```
//ddname DD DSNAME=data-set-name,  
//          [VOLUME=(PRIVATE,RETAIN,SER=volser),]  
//          UNIT=device-type,SPACE=(subparms),  
//          DISP=({NEW|MOD},PASS,KEEP)
```

ddname

Provides a link to the DD statement. The same as the *ddname* portion of the *assignment-name* used in the COBOL RERUN clause.

data-set-name

Identifies the checkpoint data set to the restart procedure. The name given to the data set used to record checkpoint records.

volser

Identifies the volume by serial number.

device-type

Identifies the device.

subparms

Specifies the amount of track space needed for the data set.

MOD Specifies the multiple contiguous checkpoint method.

NEW Specifies the single checkpoint method.

PASS Prevents deletion of the data set at successful completion of the job step, unless the job step is the last in the job. If it is the last step, the data set is deleted.

KEEP Keeps the data set if the job step abnormally ends.

“Examples: defining checkpoint data sets”

Examples: defining checkpoint data sets

The following examples show the JCL and COBOL coding you can use to define checkpoint data sets.

Writing single checkpoint records, using tape:

```
//CHECKPT DD DSNAME=CHECK1,VOLUME=SER=ND0003,  
//          UNIT=TAPE,DISP=(NEW,KEEP),LABEL=(,NL)  
          . . .  
          ENVIRONMENT DIVISION.  
          . . .  
          RERUN ON CHECKPT EVERY  
          5000 RECORDS OF ACCT-FILE.
```

Writing single checkpoint records, using disk:

```
//CHEK DD DSNAME=CHECK2,  
//      VOLUME=(PRIVATE,RETAIN,SER=DB0030),  
//      UNIT=3380,DISP=(NEW,KEEP),SPACE=(CYL,5)  
      . . .  
ENVIRONMENT DIVISION.  
      . . .  
RERUN ON CHEK EVERY  
      20000 RECORDS OF PAYCODE.  
RERUN ON CHEK EVERY  
      30000 RECORDS OF IN-FILE.
```

Writing multiple contiguous checkpoint records, using tape:

```
//CHEKPT DD DSNAME=CHECK3,VOLUME=SER=111111,  
//        UNIT=TAPE,DISP=(MOD,PASS),LABEL=(,NL)  
      . . .  
ENVIRONMENT DIVISION.  
      . . .  
RERUN ON CHEKPT EVERY  
      10000 RECORDS OF PAY-FILE.
```

Messages generated during checkpoint

The system checkpoint routine advises the operator of the status of the checkpoints taken by displaying informative messages on the console.

Each time a checkpoint is successfully completed, a message is displayed that associates the jobname (*ddname, unit, volser*) with the checkpoint taken (*checkid*).

The control program assigns *checkid* as an eight-character string. The first character is the letter C, followed by a decimal number that indicates the checkpoint. For example, the following message indicates the fourth checkpoint taken in the job step:

```
checkid C0000004
```

Restarting programs

The system restart routine retrieves the information recorded in a checkpoint record, restores the contents of main storage and all registers, and restarts the program.

You can begin the restart routine in one of two ways:

- Automatically at the time an interruption stopped the program
- At a later time as a deferred restart

The RD parameter of the job control language determines the type of restart. You can use the RD parameter on either the JOB or the EXEC statement. If coded on the JOB statement, the parameter overrides any RD parameters on the EXEC statement.

To suppress both restart and writing checkpoints, code RD=NC.

Restriction: If you try to restart at a checkpoint taken by a COBOL program during a SORT or MERGE operation, an error message is issued and the restart is canceled. Only checkpoints taken by DFSORT are valid.

Data sets that have the SYSOUT parameter coded in their DD statements are handled in various ways depending on the type of restart.

If the checkpoint data set is multivolume, include in the VOLUME parameter the sequence number of the volume on which the checkpoint entry was written. If the checkpoint data set is on a 7-track tape with nonstandard labels or no labels, the SYSCHK DD statement must contain DCB=(TRTCH=C,. . .).

RELATED TASKS

“Using checkpoint/restart with DFSORT” on page 236

“Requesting automatic restart”

“Requesting deferred restart”

Requesting automatic restart

Automatic restart occurs only at the latest checkpoint taken. If no checkpoint was taken before interruption, automatic restart occurs at the beginning of the job step.

Whenever automatic restart is to occur, the system repositions all devices except unit-record devices.

If you want automatic restart, code RD=R or RD=RNC:

- RD=R indicates that restart is to occur at the latest checkpoint. Code the RERUN clause for at least one data set in the program in order to record checkpoints. If no checkpoint is taken before interruption, restart occurs at the beginning of the job step.
- RD=RNC indicates that no checkpoint is to be written, and that any restart is to occur at the beginning of the job step. In this case, RERUN clauses are unnecessary; if any are present, they are ignored.

If you omit the RD parameter, the CHKPT macro instruction remains active, and checkpoints can be taken during processing. If an interrupt occurs after the first checkpoint, automatic restart will occur.

To restart automatically, a program must satisfy the following conditions:

- In the program you must request restart by using the RD parameter or by taking a checkpoint.
- An abend that terminated the job must return a code that allows restart.
- The operator must authorize the restart.

“Example: requesting a step restart” on page 657

Requesting deferred restart

Deferred restart can occur at any checkpoint, not necessarily the latest one taken. You can restart your program at a checkpoint other than at the beginning of the job step.

When a deferred restart has been successfully completed, the system displays a message on the console stating that the job has been restarted. Control is then given to your program.

If you want deferred restart, code the RD parameter as RD=NR. This form of the parameter suppresses automatic restart but allows a checkpoint record to be written provided that a RERUN clause was coded.

Request a deferred restart by using the RESTART parameter on the JOB card and a SYSCHK DD statement to identify the checkpoint data set. If a SYSCHK DD statement is present in a job and the JOB statement does not contain the RESTART parameter, the

SYSCHK DD statement is ignored. If a RESTART parameter without the CHECKID subparameter is included in a job, a SYSCHK DD statement must not appear before the first EXEC statement for the job.

“Example: restarting a job at a specific checkpoint step” on page 657

RELATED REFERENCES

“Formats for requesting deferred restart”

Formats for requesting deferred restart

The formats for the RESTART parameter of the JOB statement and the SYSCHK DD statements are as shown below.

```
//jobname JOB MSGLEVEL=1,RESTART=(request[,checkid])
//SYSCHK DD DSNAME=data-set-name,
//          DISP=OLD[,UNIT=device-type,
//          VOLUME=SER=volser]
```

MSGLEVEL=1 (or MSGLEVEL=(1,y))

MSGLEVEL is required.

RESTART=(request,[checkid])

Identifies the particular checkpoint at which restart is to occur.

request

Takes one of the following forms:

- * Indicates restart at the beginning of the job.

stepname

Indicates restart at the beginning of a job step.

stepname.procstep

Indicates restart at a procedure step within the job step.

checkid

Identifies the checkpoint where restart is to occur.

SYSCHK

The ddname used to identify a checkpoint data set to the control program. The SYSCHK DD statement must immediately precede the first EXEC statement of the resubmitted job, and must follow any JOBLIB statement.

data-set-name

Identifies the checkpoint data set. It must be the same name that was used when the checkpoint was taken.

device-type and volser

Identify the device type and the serial number of the volume that contains the checkpoint data set.

“Example: requesting a deferred restart”

Example: requesting a deferred restart

This example shows JCL to restart the G0 step of an IGYWCLG procedure at checkpoint identifier (CHECKID) C0000003.

```
//jobname JOB MSGLEVEL=1,RESTART=(stepname.G0,C0000003)
//SYSCHK DD DSNAME=CHKPT,
//          DISP=OLD[,UNIT=3380,VOLUME=SER=111111]
. . .
```

Resubmitting jobs for restart

When you resubmit a job for restart, be careful with any DD statements that might affect the execution of the restarted job step. The restart routine uses information from DD statements in the resubmitted job to reset files for use after restart.

If you want a data set to be deleted at the end of a job step, give it a conditional disposition of PASS or KEEP (rather than DELETE). This disposition allows the data set to be available if an interruption forces a restart. If you want to restart a job at the beginning of a step, you must first discard any data set created (defined as NEW in a DD statement) in the previous run, or change the DD statement to mark the data set as OLD.

The system automatically repositions input data sets that are on tape or disk.

“Example: resubmitting a job for a step restart”

“Example: resubmitting a job for a checkpoint restart” on page 658

Example: restarting a job at a specific checkpoint step

This example shows a sequence of job control statements for restarting a job at a specific step.

```
//PAYROLL JOB MSGLEVEL=1,REGION=80K,  
//          RESTART=(STEP1,CHECKPT4)  
//JOBLIB DD DSNAME=PRIV.LIB3,DISP=OLD  
//SYSCHK DD DSNAME=CHKPTLIB,  
//          [UNIT=TAPE,VOL=SER=456789,]  
//          DISP=(OLD,KEEP)  
//STEP1 EXEC PGM=PROG4,TIME=5
```

Example: requesting a step restart

This example shows the use of the RD parameter, which requests step restart for any abnormally terminated job step.

```
//J1234 JOB 386,SMITH,MSGLEVEL=1,RD=R  
//S1 EXEC PGM=MYPROG  
//INDATA DD DSNAME=INVENT[,UNIT=TAPE],DISP=OLD,  
//          [VOLUME=SER=91468,]  
//          LABEL=RETPD=14  
//REPORT DD SYSOUT=A  
//WORK DD DSNAME=T91468,DISP=(,KEEP),  
//          UNIT=SYSDA,SPACE=(3000,(5000,500)),  
//          VOLUME=(PRIVATE,RETAIN,,6)  
//DDCKPNT DD UNIT=TAPE,DISP=(MOD,PASS,CATLG),  
//          DSNAME=C91468,LABEL=(,NL)
```

The DDCKPNT DD statement defines a checkpoint data set. For this step, after a RERUN clause is performed, only automatic checkpoint restart can occur unless a CHKPT cancel is issued.

Example: resubmitting a job for a step restart

This example shows the changes that you might make to the JCL before you resubmit a job for step restart.

```
//J3412 JOB 386,SMITH,MSGLEVEL=1,RD=R,RESTART=*  
//S1 EXEC PGM=MYPROG  
//INDATA DD DSNAME=INVENT[,UNIT=TAPE],DISP=OLD,  
//          [VOLUME=SER=91468,]LABEL=RETPD=14  
//REPORT DD SYSOUT=A  
//WORK DD DSNAME=S91468,  
//          DISP=(,KEEP),UNIT=SYSDA,
```

```
//          SPACE=(3000,(5000,500)),
//          VOLUME=(PRIVATE,RETAIN,,6)
//DDCHKPNT DD UNIT=TAPE,DISP=(MOD,PASS,CATLG),
//          DSNAME=R91468,LABEL=(,NL)
```

The following changes were made in the example above:

- The job name has been changed (from J1234 to J3412) to distinguish the original job from the restarted job.
- The RESTART parameter has been added to the JOB statement, and indicates that restart is to begin with the first job step.
- The WORK DD statement was originally assigned a conditional disposition of KEEP for this data set:
 - If the step terminated normally in the previous run of the job, the data set was deleted, and no changes need to be made to this statement.
 - If the step abnormally terminated, the data set was kept. In that case, define a new data set (S91468 instead of T91468, as shown), or change the status of the data set to OLD before resubmitting the job.
- A new data set (R91468 instead of C91468) has also been defined as the checkpoint data set.

“Example: requesting a step restart” on page 657

Example: resubmitting a job for a checkpoint restart

This example shows the changes that you might make to JCL before you resubmit a job for checkpoint restart.

```
//J3412   JOB 386,SMITH,MSGLEVEL=1,RD=R,
//          RESTART=(*,C0000002)
//SYSCHK DD DSNAME=C91468,DISP=OLD
//S1     EXEC PGM=MYPROG
//INDATA DD DSNAME=INVENT,UNIT=TAPE,DISP=OLD,
//          VOLUME=SER=91468,LABEL=RETPD=14
//REPORT DD SYSOUT=A
//WORK   DD DSNAME=T91468,DISP=(,KEEP),
//          UNIT=SYSDA,SPACE=(3000,(5000,500)),
//          VOLUME=(PRIVATE,RETAIN,,6)
//DDCKPNT DD UNIT=TAPE,DISP=(MOD,KEEP,CATLG),
//          DSNAME=C91468,LABEL=(,NL)
```

The following changes were made in the example above:

- The job name has been changed (from J1234 to J3412) to distinguish the original job from the restarted job.
- The RESTART parameter has been added to the JOB statement, and indicates that restart is to begin with the first step at the checkpoint entry named C0000002.
- The DD statement DDCKPNT was originally assigned a conditional disposition of CATLG for the checkpoint data set:
 - If the step terminated normally in the previous run of the job, the data set was kept. In that case, the SYSCHK DD statement must contain all of the information necessary for retrieving the checkpoint data set.
 - If the job abnormally terminated, the data set was cataloged. In that case, the only parameters required on the SYSCHK DD statement are DSNAME and DISP as shown.

If a checkpoint is taken in a job that is running when V=R is specified, the job cannot be restarted until adequate nonpageable dynamic storage becomes available.

Part 8. Improving performance and productivity

Chapter 33. Tuning your program

When a program is comprehensible, you can assess its performance. A tangled control flow makes a program difficult to understand and maintain, and inhibits the optimization of its code.

To improve the performance of your program, examine at least these aspects:

- Underlying algorithms: For best performance, using sound algorithms is essential. For example:
 - A sophisticated algorithm for sorting a million items might be hundreds of thousands of times faster than a simple algorithm.
 - If the program frequently accesses data, reduce the number of steps to access the data.
- Data structures: Using data structures that are appropriate for the algorithms is essential.

You can write programs that result in better generated code sequences and use system services more efficiently. These additional aspects can affect performance:

- Coding techniques: Use a programming style that enables the optimizer to choose efficient data types and handle tables efficiently.
- Optimization: You can optimize code by using the OPTIMIZE compiler option.
- Compiler options and USE FOR DEBUGGING ON ALL PROCEDURES: Some compiler options and language affect program efficiency.
- Runtime environment: Consider your choice of runtime options.
- Running under CICS, IMS, or VSAM: Heeding various tips can help make these programs run more efficiently.

RELATED CONCEPTS

“Optimization” on page 667
Enterprise COBOL Version 4 Performance Tuning

RELATED TASKS

“Using an optimal programming style”
“Choosing efficient data types” on page 662
“Handling tables efficiently” on page 664
“Optimizing your code” on page 667
“Choosing compiler features to enhance performance” on page 668
“Running efficiently with CICS, IMS, or VSAM” on page 672
Language Environment Programming Guide (Specifying runtime options)

RELATED REFERENCES

“Performance-related compiler options” on page 669
Language Environment Programming Guide (Storage performance considerations)

Using an optimal programming style

The coding style you use can affect how the optimizer handles your code. You can improve optimization by using structured programming techniques, factoring expressions, using symbolic constants, and grouping constant and duplicate computations.

RELATED TASKS

“Using structured programming”

“Factoring expressions”

“Using symbolic constants”

Using structured programming

Using structured programming statements, such as EVALUATE and inline PERFORM, makes your program more comprehensible and generates a more linear control flow. As a result, the optimizer can operate over larger regions of the program, which gives you more efficient code.

Use top-down programming constructs. Out-of-line PERFORM statements are a natural means of doing top-down programming. Out-of-line PERFORM statements can often be as efficient as inline PERFORM statements, because the optimizer can simplify or remove the linkage code.

Avoid using the following constructs:

- ALTER statements
- Explicit GO TO statements
- PERFORM procedures that involve irregular control flow (such as preventing control from passing to the end of the procedure and returning to the PERFORM statement)

Factoring expressions

By factoring expressions in your programs, you can potentially eliminate a lot of unnecessary computation.

For example, the first block of code below is more efficient than the second block of code:

```
MOVE ZERO TO TOTAL
PERFORM VARYING I FROM 1 BY 1 UNTIL I = 10
  COMPUTE TOTAL = TOTAL + ITEM(I)
END-PERFORM
COMPUTE TOTAL = TOTAL * DISCOUNT

MOVE ZERO TO TOTAL
PERFORM VARYING I FROM 1 BY 1 UNTIL I = 10
  COMPUTE TOTAL = TOTAL + ITEM(I) * DISCOUNT
END-PERFORM
```

The optimizer does not factor expressions.

Using symbolic constants

To have the optimizer recognize a data item as a constant throughout the program, initialize it with a VALUE clause and do not change it anywhere in the program.

If you pass a data item to a subprogram BY REFERENCE, the optimizer treats it as an external data item and assumes that it is changed at every subprogram call.

Choosing efficient data types

Using the SYNCHRONIZED clause can produce more efficient code.

Consistent data types can reduce the need for conversions during operations on data items. You can also improve program performance by carefully determining when to use fixed-point and floating-point data types.

RELATED CONCEPTS

“Formats for numeric data” on page 47

RELATED TASKS

“Choosing efficient computational data items”

“Using consistent data types”

“Making arithmetic expressions efficient” on page 664

“Making exponentiations efficient” on page 664

Choosing efficient computational data items

When you use a data item mainly for arithmetic or as a subscript, code `USAGE BINARY` on the data description entry for the item. The operations for manipulating binary data are faster than those for manipulating decimal data.

However, if a fixed-point arithmetic statement has intermediate results with a large precision (number of significant digits), the compiler uses decimal arithmetic anyway, after converting the operands to packed-decimal form. For fixed-point arithmetic statements, the compiler normally uses binary arithmetic for simple computations with binary operands if the precision is eight or fewer digits. Above 18 digits, the compiler always uses decimal arithmetic. With a precision of nine to 18 digits, the compiler uses either form.

To produce the most efficient code for a `BINARY` data item, ensure that it has:

- A sign (an `S` in its `PICTURE` clause)
- Eight or fewer digits

For a data item that is larger than eight digits or is used with `DISPLAY` or `NATIONAL` data items, use `PACKED-DECIMAL`. The code generated for `PACKED-DECIMAL` data items can be as fast as that for `BINARY` data items in some cases, especially if the statement is complicated or specifies rounding.

To produce the most efficient code for a `PACKED-DECIMAL` data item, ensure that it has:

- A sign (an `S` in its `PICTURE` clause)
- An odd number of digits (9s in the `PICTURE` clause), so that it occupies an exact number of bytes without a half byte left over
- 15 or fewer digits in the `PICTURE` specification on `ARCH(7)` machines. If a `PACKED-DECIMAL` data item has more than 31 digits, library routines are used. For a `PACKED-DECIMAL` data item with 16-31 digits on `ARCH(8)` or higher level machines, the compiler uses instructions that are more efficient than library calls, but not as fast as if the data item has 15 or fewer digits.

Using consistent data types

In operations on operands of different types, one of the operands must be converted to the same type as the other. Each conversion requires several instructions. For example, one of the operands might need to be scaled to give it the appropriate number of decimal places.

You can largely avoid conversions by using consistent data types and by giving both operands the same usage and also appropriate `PICTURE` specifications. That is,

you should ensure that two numbers to be compared, added, or subtracted not only have the same usage but also the same number of decimal places (9s after the V in the PICTURE clause).

Making arithmetic expressions efficient

Computation of arithmetic expressions that are evaluated in floating point is most efficient when the operands need little or no conversion. Use operands that are COMP-1 or COMP-2 to produce the most efficient code.

Define integer items as BINARY or PACKED-DECIMAL with nine or fewer digits to afford quick conversion to floating-point data. Also, conversion from a COMP-1 or COMP-2 item to a fixed-point integer with nine or fewer digits, without SIZE ERROR in effect, is efficient when the value of the COMP-1 or COMP-2 item is less than 1,000,000,000.

Making exponentiations efficient

Use floating point for exponentiations for large exponents to achieve faster evaluation and more accurate results.

For example, the first statement below is computed more quickly and accurately than the second statement:

```
COMPUTE fixed-point1 = fixed-point2 ** 100000.E+00
```

```
COMPUTE fixed-point1 = fixed-point2 ** 100000
```

A floating-point exponent causes floating-point arithmetic to be used to compute the exponentiation.

Using VOLATILE clauses efficiently

Optimization of data items that are defined with the VOLATILE clause is significantly restricted. Therefore, use the VOLATILE clause only when appropriate.

In particular, it is important to understand that when the VOLATILE clause is used on a group item, the compiler treats all data items subordinate to the group item as volatile, and all higher-level group items that contain the volatile group item are treated as volatile, too. If a particular member of a group needs to be treated as volatile, specify the VOLATILE clause on the data description entry for that item only, where possible.

At present, the primary reason to use the VOLATILE clause is for data items that are set or referenced inside an LE condition handler but are defined outside the LE condition handler program. The VOLATILE clause guarantees that such items are handled correctly by the optimizer. For more information on when to use VOLATILE, see *VOLATILE clause* in the *Enterprise COBOL Language Reference*.

Handling tables efficiently

You can use several techniques to improve the efficiency of table-handling operations, and to influence the optimizer. The return for your efforts can be significant, particularly when table-handling operations are a major part of an application.

The following two guidelines affect your choice of how to refer to table elements:

- Use indexing rather than subscripting.

Although the compiler can eliminate duplicate indexes and subscripts, the original reference to a table element is more efficient with indexes (even if the subscripts were BINARY). The value of an index has the element size factored into it, whereas the value of a subscript must be multiplied by the element size when the subscript is used. The index already contains the displacement from the start of the table, and this value does not have to be calculated at run time. However, subscripting might be easier to understand and maintain.

- Use relative indexing.

Relative index references (that is, references in which an unsigned numeric literal is added to or subtracted from the index-name) are executed at least as fast as direct index references, and sometimes faster. There is no merit in keeping alternative indexes with the offset factored in.

Whether you use indexes or subscripts, the following coding guidelines can help you get better performance:

- Specify the element length so that it matches that of related tables.

When you index or subscript tables, it is most efficient if all the tables have the same element length. That way, the stride for the last dimension of the tables is the same, and the optimizer can reuse the rightmost index or subscript computed for one table. If both the element lengths and the number of occurrences in each dimension are equal, then the strides for dimensions other than the last are also equal, resulting in greater commonality between their subscript computations. The optimizer can then reuse indexes or subscripts other than the rightmost.

- Avoid errors in references by coding index and subscript checks into your program.

If you need to validate indexes and subscripts, it might be faster to code your own checks than to use the SSRANGE compiler option.

You can also improve the efficiency of tables by using these guidelines:

- Use binary data items for all subscripts.

When you use subscripts to address a table, use a BINARY signed data item with eight or fewer digits. In some cases, using four or fewer digits for the data item might also improve processing time.

- Use binary data items for variable-length table items.

For tables with variable-length items, you can improve the code for OCCURS DEPENDING ON (ODO). To avoid unnecessary conversions each time the variable-length items are referenced, specify BINARY for OCCURS . . . DEPENDING ON objects.

- Use fixed-length data items whenever possible.

Copying variable-length data items into a fixed-length data item before a period of high-frequency use can reduce some of the overhead associated with using variable-length data items.

- Organize tables according to the type of search method used.

If the table is searched sequentially, put the data values most likely to satisfy the search criteria at the beginning of the table. If the table is searched using a binary search algorithm, put the data values in the table sorted alphabetically on the search key field.

RELATED CONCEPTS

“Optimization of table references” on page 666

RELATED TASKS

“Referring to an item in a table” on page 70

“Choosing efficient data types” on page 662

RELATED REFERENCES

“SSRANGE” on page 361

Optimization of table references

The COBOL compiler optimizes table references in several ways.

For the table element reference `ELEMENT(S1 S2 S3)`, where `S1`, `S2`, and `S3` are subscripts, the compiler evaluates the following expression:

```
comp_s1 * d1 + comp_s2 * d2 + comp_s3 * d3 + base_address
```

Here `comp_s1` is the value of `S1` after conversion to binary, `comp_s2` is the value of `S2` after conversion to binary, and so on. The strides for each dimension are `d1`, `d2`, and `d3`. The *stride* of a given dimension is the distance in bytes between table elements whose occurrence numbers in that dimension differ by 1 and whose other occurrence numbers are equal. For example, the stride `d2` of the second dimension in the above example is the distance in bytes between `ELEMENT(S1 1 S3)` and `ELEMENT(S1 2 S3)`.

Index computations are similar to subscript computations, except that no multiplication needs to be done. Index values have the stride factored into them. They involve loading the indexes into registers, and these data transfers can be optimized, much as the individual subscript computation terms are optimized.

Optimization of variable-length items

A group item that contains a subordinate `OCCURS DEPENDING ON` data item has a variable length. The program must perform special code every time a variable-length data item is referenced.

Because this code is out-of-line, it might interrupt optimization. Furthermore, the code to manipulate variable-length data items is much less efficient than that for fixed-size data items and can significantly increase processing time. For instance, the code to compare or move a variable-length data item might involve calling a library routine and is much slower than the same code for fixed-length data items.

Comparison of direct and relative indexing

Relative index references are as fast as or faster than direct index references.

The direct indexing in `ELEMENT (I5, J3, K2)` requires this preprocessing:

```
SET I5 TO I  
SET I5 UP BY 5  
SET J3 TO J  
SET J3 DOWN BY 3  
SET K2 TO K  
SET K2 UP BY 2
```

This processing makes the direct indexing less efficient than the relative indexing in `ELEMENT (I + 5, J - 3, K + 2)`.

RELATED CONCEPTS

“Optimization” on page 667

Optimizing your code

When your program is ready for final testing, specify the `OPTIMIZE(1|2)` compiler option so that the tested code and the production code are identical.

If you frequently run a program without recompiling it during development, you might also want to use `OPTIMIZE(1|2)`. However, if you recompile frequently, the overhead for `OPTIMIZE(1|2)` might outweigh its benefits unless you are using the assembler language expansion (`LIST` compiler option) to fine-tune the program.

For unit-testing a program, you will probably find it easier to debug code that has not been optimized.

To see how the optimizer works on a program, compile it with different levels of optimization and compare the generated code. (Use the `LIST` compiler option to request the assembler listing of the generated code.)

RELATED CONCEPTS

"Optimization"

RELATED REFERENCES

"LIST" on page 334

"OPTIMIZE" on page 346

Optimization

To improve the efficiency of the generated code, you can use the `OPTIMIZE(1)` or `OPTIMIZE(2)` compiler option.

`OPTIMIZE(1)` causes the COBOL optimizer to do the following optimizations:

- Eliminate unnecessary transfers of control and inefficient branches, including those generated by the compiler that are not evident from looking at the source program.
- Simplify the compiled code for a `PERFORM` statement. The compiler replicates the `PERFORM` a number of times to avoid linkage code.
- Eliminate duplicate computations (such as subscript computations and repeated statements) that have no effect on the results of the program.
- Eliminate constant computations by performing them when the program is compiled.
- Eliminate constant conditional expressions.
- Aggregate moves of contiguous items (such as those that often occur with the use of `MOVE CORRESPONDING`) into a single move. Both the source and target must be contiguous for the moves to be aggregated.
- Delete from the program, and identify with a warning message, code that can never be performed (unreachable code elimination).
- Discard unreferenced data items from the `DATA DIVISION`, and suppress generation of code to initialize these data items to their `VALUE` clauses. (The optimizer takes this action only when you use the `STGOPT` option.)

`OPTIMIZE(2)` causes the COBOL optimizer to do further optimizations:

- Simplify operations more aggressively and schedule instructions.

- Do interblock optimizations such as global value propagation and loop invariant code motion.

Contained program procedure integration

In contained program procedure integration, the contained program code replaces a CALL to a contained program. The resulting program runs faster without the overhead of CALL linkage and with more linear control flow.

Program size: If several CALL statements call contained programs and these programs replace each such statement, the containing program can become large. The optimizer then chooses the next best optimization for the CALL statement.

RELATED CONCEPTS

“Optimization of table references” on page 666

“PERFORM procedure integration”

RELATED REFERENCES

“OPTIMIZE” on page 346

PERFORM procedure integration

PERFORM procedure integration is the process whereby a PERFORM statement is replaced by its performed procedures. The advantage is that the resulting program runs faster without the overhead of PERFORM linkage and with more orderly control flow.

Program size: If the performed procedures are invoked by several PERFORM statements and replace each such statement, the program could become large. The optimizer limits this increase, after which it no longer integrates these procedures.

Choosing compiler features to enhance performance

Your choice of performance-related compiler options and your use of the USE FOR DEBUGGING ON ALL PROCEDURES statement can affect how well your program is optimized.

You might have a customized system that requires certain options for optimum performance. Do these steps:

1. To see what your system defaults are, get a short listing for any program and review the listed option settings.
2. Determine which options are fixed as nonoverridable at your installation by checking with your system programmer.
3. For the options not fixed at installation, select performance-related options for compiling your programs.

Important: Confer with your system programmer about how to tune COBOL programs. Doing so will ensure that the options you choose are appropriate for programs at your site.

Another compiler feature to consider is the USE FOR DEBUGGING ON ALL PROCEDURES statement. It can greatly affect the compiler optimizer. The ON ALL PROCEDURES option generates extra code at each transfer to a procedure name. Although very useful for debugging, it can make the program significantly larger and inhibit optimization substantially.

Although COBOL allows segmentation language, you will not improve storage allocation by using it, because COBOL does not perform overlay.

RELATED CONCEPTS

“Optimization” on page 667

RELATED TASKS

“Optimizing your code” on page 667

“Getting listings” on page 395

RELATED REFERENCES

“Performance-related compiler options”

Performance-related compiler options

In the table below you can see a description of the purpose of each option, its performance advantages and disadvantages, and usage notes where applicable.

Table 89. Performance-related compiler options

Compiler option	Purpose	Performance advantages	Performance disadvantages	Usage notes
AFP(NOVOLATILE) (see “AFP” on page 307)	To control the compiler usage of the Additional Floating Point (AFP) registers that are provided by z/Architecture processors	AFP(NOVOLATILE) lets the compiler generate more efficient code sequences for programs with floating point operations.	None	Poorly behaved assembler code might not adhere to the standard calling convention and might fail to correctly preserve values in Floating Point registers. With AFP(NOVOLATILE), COBOL programs can safely call such routines.
ARCH (see “ARCH” on page 307)	To specify the machine architecture for which the executable program instructions are to be generated	If you specify a higher ARCH level, the machine generates code that uses newer and faster instructions instead of the sequences of common instructions.	None	Your application might abend if it runs on a processor with an architecture level lower than that specified for the ARCH option.
ARITH(EXTEND) (see “ARITH” on page 309)	To increase the maximum number of digits allowed for decimal numbers	None	ARITH(EXTEND) causes some degradation in performance for all decimal data types because of larger intermediate results.	The amount of degradation that you experience depends directly on the amount of decimal data that you use.
AWO (see “AWO” on page 310)	To get optimum use of buffer and device space for QSAM files	Can result in performance savings, because this option results in fewer calls to data management services to handle input and output	None	If you use AWO, the APPLY WRITE-ONLY clause is in effect for all QSAM files in the program that have V-mode records.
BLOCK0 (see “BLOCK0” on page 310)	To take advantage of system-determined block size for QSAM output files	Can result in enhanced processing speed and minimized storage requirements for QSAM output files	None	If you use BLOCK0, a BLOCK CONTAINS 0 clause is activated for all QSAM files in the program that specify neither BLOCK CONTAINS nor RECORDING MODE U in the file description entry.
DATA(31) (see “DATA” on page 318)	To have DFSMS allocate QSAM buffers above the 16 MB line (by using the RENT and DATA(31) compiler options)	Because extended-format QSAM data sets can require many buffers, allocating the buffers in unrestricted storage avoids virtual storage constraint problems.	None	On a z/OS system with DFSMS, if your application processes striped extended-format QSAM data sets, use the RENT and DATA(31) compiler options to have the input-output buffers for your QSAM files allocated from storage above the 16 MB line.

Table 89. Performance-related compiler options (continued)

Compiler option	Purpose	Performance advantages	Performance disadvantages	Usage notes
DYNAM (see "DYNAM" on page 323)	To have subprograms (called through the CALL statement) dynamically loaded at run time	Subprograms are easier to maintain, because the application does not have to be link-edited again if a subprogram is changed.	There is a slight performance penalty, because the call must go through a Language Environment routine.	To free virtual storage that is no longer needed, issue the CANCEL statement.
FASTSRT (see "FASTSRT" on page 327)	To specify that the IBM DFSORT product (or equivalent) will handle all of the input and output	Eliminates the overhead of returning to Enterprise COBOL after each record is processed	None	FASTSRT is recommended if direct work files are used for the sort work files. Not all sorts are eligible for this option.
HGPR (see "HGPR" on page 331)	To control the compiler usage of the 64-bit registers provided by z/Architecture processors.	If you specify HGPR(NOPRESERVE), the compiler omits preserving the high-halves of the 64-bit GPRs that a program is using, which improves performance.	None	If your program modifies and does not save the high-halves of the registers, but calling programs depend on the unchanged values, the application might give incorrect results. Exception: It does not apply if the caller of this program is Enterprise COBOL, Enterprise PL/I or z/OS XL C/C++ programs.
MAXPCF (see "MAXPCF" on page 336)	To reduce optimization in programs that require excessive compilation time or excessive storage requirements because of large sizes or complexity.	None	If you specify MAXPCF(<i>n</i>) and <i>n</i> is not zero, when the program complexity factor exceeds <i>n</i> , any specification of OPTIMIZE(1) or OPTIMIZE(2) is reset to OPTIMIZE(0), and a warning message is generated.	None
NUMPROC(PFD) (see "NUMPROC" on page 343)	To have invalid sign processing bypassed for numeric operations	Generates significantly more efficient code for numeric comparisons	For most references to COMP-3 and DISPLAY numeric data items, NUMPROC(PFD) inhibits extra code from being generated to "fix up" signs. This extra code might also inhibit some other types of optimizations. The extra code is generated with NUMPROC(NOPFD).	If you use NUMPROC(PFD), the compiler assumes and requires that all decimal items contain the preferred sign values and bypasses the sign "fix-up" process. However, because not all external data files contain the proper signs for COMP-3 or DISPLAY numeric data, and programs might use REDEFINES, group moves, or parameter passing in ways that do not ensure preferred signs, the NUMPROC(PFD) might not be appropriate for many programs.
OPTIMIZE(0 1 2) (see "OPTIMIZE" on page 346)	To optimize generated code for better performance	Generally results in more efficient runtime code	Longer compile time: OPTIMIZE(1 2) requires more processing time for compiles than OPTIMIZE(0).	OPTIMIZE(0) is generally used during program development when frequent compiles are needed; it also allows for symbolic debugging. For production runs, OPTIMIZE(1 2) is recommended.
STGOPT (see "STGOPT" on page 362)	To optimize storage allocation in DATA DIVISION	Generally results in less storage usage	None	STGOPT deletes unused data items, which might be undesirable in the case of time stamps or data items that are used only as markers for dump reading.
RENT (see "RENT" on page 352)	To generate a reentrant program	Enables the program to be placed in shared storage (LPA/ELPA) for faster execution	Generates additional code to ensure that the program is reentrant	None

Table 89. Performance-related compiler options (continued)

Compiler option	Purpose	Performance advantages	Performance disadvantages	Usage notes
RMODE (ANY) (see "RMODE" on page 353)	To let the program be loaded anywhere	None	None	None
SSRANGE (see "SSRANGE" on page 361)	To verify that all table references and reference modification expressions are in proper bounds	SSRANGE generates additional code for verifying table references. Using NOSSRANGE causes that code not to be generated.	With SSRANGE specified, checks for valid ranges do affect compiler performance.	In general, if you need to verify the table references only a few times instead of at every reference, coding your own checks might be faster than using SSRANGE. For performance-sensitive applications, NOSSRANGE is recommended.
TEST (see "TEST" on page 364)	To get full debugging capability when using Debug Tool and to get a symbolic dump of the data items in CEEDUMP. You can also get a symbolic dump of the data items in CEEDUMP with NOTEST (DWARF).	None	Some reduction in optimization occurs when the TEST option is used. More reduction in optimization occurs when the EJPD suboption of TEST is used.	For production runs, using NOTEST or TEST (NOEJPD) is recommended. If during a production run, you want a symbolic dump of the data items in a formatted dump if the program abends, compile using TEST or with NOTEST (DWARF).
THREAD (see "THREAD" on page 366)	To enable programs for execution in a Language Environment enclave that has multiple POSIX threads or PL/I tasks	None	There is a slight performance penalty because of the overhead of serialization logic.	A slight performance penalty occurs in either a threaded or nonthreaded environment.
TRUNC (OPT) (see "TRUNC" on page 368)	To avoid having code generated to truncate the receiving fields of arithmetic operations	Does not generate extra code and generally improves performance	Both TRUNC (BIN) and TRUNC (STD) generate extra code whenever a BINARY data item is changed. TRUNC (BIN) is usually the slowest of these options.	TRUNC (STD) conforms to the 85 COBOL Standard, but TRUNC (BIN) and TRUNC (OPT) do not. With TRUNC (OPT), the compiler assumes that the data conforms to the PICTURE and USAGE specifications. TRUNC (OPT) is recommended where possible.

RELATED CONCEPTS

- "Optimization" on page 667
- "Storage and its addressability" on page 39

RELATED TASKS

- "Generating a list of compiler messages" on page 280
- "Evaluating performance" on page 672
- "Optimizing buffer and device space" on page 10
- "Choosing compiler features to enhance performance" on page 668
- "Improving sort performance with FASTSORT" on page 231
- "Using striped extended-format QSAM data sets" on page 180
- "Handling tables efficiently" on page 664

RELATED REFERENCES

- "Sign representation of zoned and packed-decimal data" on page 53
- "Allocation of buffers for QSAM files" on page 181
- Chapter 17, "Compiler options," on page 301
- "Conflicting compiler options" on page 304

Evaluating performance

Fill in the following worksheet to help you evaluate the performance of your program. If you answer yes to each question, you are probably improving the performance.

In thinking about the performance tradeoff, be sure you understand the function of each option as well as the performance advantages and disadvantages. You might prefer function over increased performance in many instances.

Table 90. Performance-tuning worksheet

Compiler option	Consideration	Yes?
ARCH	Do you use the highest architecture level possible for all environments in which your programs will run? For example, if the lowest level architecture you have including your disaster recovery machines is z10™, are you using ARCH(8)?	
AWO	Do you use the AWO option when possible?	
BLOCK0	Do you use BLOCK0 for QSAM files?	
DATA	When you use QSAM striped data sets, do you use the RENT and DATA(31) options? Is the program object AMODE 31? Are you running with ALL31(ON)?	
DYNAM	Can you use NODYNAM? Consider the performance tradeoffs.	
FASTSRT	When you use direct work files for the sort work files, did you use the FASTSRT option?	
NUMPROC	Do you use NUMPROC(PFD) when possible?	
OPTIMIZE	Do you use a non-zero OPTIMIZE level for production runs?	
SSRANGE	Do you use NOSSRANGE for production runs?	
TEST	Do you use NOTEST or TEST(NOEJPD) for production runs?	
TRUNC	Do you use TRUNC(OPT) when possible?	
ZONEDATA	Do you use ZONEDATA(PFD) when possible?	

RELATED CONCEPTS

“Storage and its addressability” on page 39

RELATED TASKS

“Choosing compiler features to enhance performance” on page 668

RELATED REFERENCES

“Performance-related compiler options” on page 669

Running efficiently with CICS, IMS, or VSAM

You can improve performance for online programs running under CICS or IMS, or programs that use VSAM, by following these tips.

CICS: If your application runs under CICS, convert EXEC CICS LINK commands to COBOL CALL statements to improve transaction response time.

IMS: If your application runs under IMS, preloading the application program and the library routines can help reduce the overhead of loading and searching. It can also reduce the input-output activity.

For better system performance, use the RENT compiler option and preload the applications and library routines when possible. You can also use the Language Environment library routine retention (LRR) function to improve performance in IMS/TM regions.

VSAM: When you use VSAM files, increase the number of data buffers for sequential access or index buffers for random access. Also, select a control interval size (CISZ) that is appropriate for the application. A smaller CISZ results in faster retrieval for random processing at the expense of inserts. A larger CISZ is more efficient for sequential processing.

For better performance, access the records sequentially and avoid using multiple alternate indexes when possible. If you use alternate indexes, access method services builds them more efficiently than the AIXBLD runtime option.

RELATED TASKS

“Coding COBOL programs to run under CICS” on page 429
Chapter 22, “Developing COBOL programs for IMS,” on page 453
“Improving VSAM performance” on page 209
Language Environment Customization

RELATED REFERENCES

Language Environment Programming Guide (Specifying runtime options)

Choosing static or dynamic calls

If you can arrange your modules, and the programs that frequently call each other are in one module, static calls are faster than dynamic calls.

For more information, see “Performance considerations of static and dynamic calls” on page 481.

RELATED CONCEPTS

“Performance considerations of static and dynamic calls” on page 481

Chapter 34. Simplifying coding

You can use coding techniques to improve your productivity. By using the COPY statement, the format 2 SORT statement, COBOL intrinsic functions, and Language Environment callable services, you can avoid repetitive coding and having to code many arithmetic calculations or other complex tasks.

If your program contains frequently used code sequences (such as blocks of common data items, input-output routines, error routines, or even entire COBOL programs), write the code sequences once and put them in a COBOL copy library. You can use the COPY statement to retrieve these code sequences and have them included in your program at compile time. Using copybooks in this manner eliminates repetitive coding.

To sort a table, you can use the format 2 SORT statement to simplify coding. It provides a much simpler way compared to the format 1 SORT statement.

COBOL provides various capabilities for manipulating strings and numbers. These capabilities can help you simplify your coding.

The Language Environment date and time callable services store dates as fullword binary integers and store time stamps as long (64-bit) floating-point values. These formats let you do arithmetic calculations on date and time values simply and efficiently. You do not need to write special subroutines that use services outside the language library to perform such calculations.

RELATED TASKS

“Using numeric intrinsic functions” on page 57

“Using math-oriented callable services” on page 59

“Using date callable services” on page 60

“Eliminating repetitive coding”

“Converting data items (intrinsic functions)” on page 116

“Evaluating data items (intrinsic functions)” on page 119

“Using Language Environment callable services” on page 677

RELATED REFERENCES

“Using the format 2 SORT statement to sort a table” on page 681

Eliminating repetitive coding

To include stored source statements in a program, use the COPY statement in any program division and at any code sequence level. You can nest COPY statements to any depth.

To specify more than one copy library, use either multiple system definitions or a combination of multiple definitions and the IN/OF phrase (*IN/OF library-name*):

MVS batch

Use JCL to concatenate data sets in your SYSLIB DD statement.

Alternatively, define multiple DD statements and use the IN/OF phrase of the COPY statement.

TSO Use the ALLOCATE command to concatenate data sets for SYSLIB. Alternatively, issue multiple ALLOCATE statements and use the IN/OF phrase of the COPY statement.

z/OS UNIX

Use the SYSLIB environment variable to define multiple paths to your copybooks. Alternatively, use multiple environment variables and use the IN/OF phrase of the COPY statement.

For example:

```
COPY MEMBER1 OF COPYLIB
```

If you omit this qualifying phrase, the default is SYSLIB.

COPY and debugging line: In order for the text copied to be treated as debug lines, for example, as if there were a D inserted in column 7, put the D on the first line of the COPY statement. A COPY statement cannot itself be a debugging line; if it contains a D, and WITH DEBUGGING mode is not specified, the COPY statement is nevertheless processed.

“Example: using the COPY statement”

RELATED REFERENCES

Chapter 18, “Compiler-directing statements,” on page 381

Example: using the COPY statement

These examples show how you can use the COPY statement to include library text in a program.

Suppose the library entry CFILEA consists of the following FD entries:

```
      BLOCK CONTAINS 20 RECORDS
      RECORD CONTAINS 120 CHARACTERS
      LABEL RECORDS ARE STANDARD
      DATA RECORD IS FILE-OUT.
01  FILE-OUT      PIC X(120).
```

You can retrieve the text-name CFILEA by using the COPY statement in a source program as follows:

```
FD FILEA
      COPY CFILEA.
```

The library entry is copied into your program, and the resulting program listing looks like this:

```
FD FILEA
      COPY CFILEA.
C  BLOCK CONTAINS 20 RECORDS
C  RECORD CONTAINS 120 CHARACTERS
C  LABEL RECORDS ARE STANDARD
C  DATA RECORD IS FILE-OUT.
C  01  FILE-OUT      PIC X(120).
```

In the compiler source listing, the COPY statement prints on a separate line. C precedes copied lines.

Assume that a copybook with the text-name DOWORK is stored by using the following statements:

```
COMPUTE QTY-ON-HAND = TOTAL-USED-NUMBER-ON-HAND
MOVE QTY-ON-HAND to PRINT-AREA
```

To retrieve the copybook identified as DOWORK, code:

```
paragraph-name.
COPY DOWORK.
```

The statements that are in the DOWORK procedure will follow *paragraph-name*.

If you use the EXIT compiler option to provide a LIBEXIT module, your results might differ from those shown here.

Note: To save compile time, you might group related items in a copybook, but not necessarily have a single large copybook with unrelated items in it.

RELATED TASKS

“Eliminating repetitive coding” on page 675

RELATED REFERENCES

Chapter 18, “Compiler-directing statements,” on page 381

Using Language Environment callable services

Language Environment callable services make many types of programming tasks easier. You call them by using the CALL statement.

Language Environment services help you with the following tasks:

- Handling conditions

The Language Environment condition-handling facilities enable COBOL applications to react to unexpected errors. You can use language constructs or runtime options to select the level at which to handle each condition. For example, you can handle a particular error in your COBOL program, let Language Environment take care of it, or have the operating system handle it.

In support of Language Environment condition handling, COBOL provides procedure-pointer data items.

- Managing dynamic storage

These services enable you to get, free, and reallocate storage. You can also create your own storage pools.

- Calculating dates and times

If you use the date and time services, you can get the current local time and date in several formats, and perform date and time conversions. Two callable services, CEEQCEN and CEESCEN, provide a predictable way to handle two-digit years, such as 91 for 1991 or 09 for 2009.

- Making math calculations

Calculations that are easy to perform with mathematical callable services include logarithmic, exponential, trigonometric, square root, and integer functions.

COBOL also supports a set of intrinsic functions that include some of the same mathematical and date functions as those provided by the callable services. The Language Environment callable services and intrinsic functions provide equivalent results, with a few exceptions. You should be familiar with these differences before deciding which to use.

- Handling messages

Message-handling services include services for getting, dispatching, and formatting messages. Messages for non-CICS applications can be directed to files or printers. CICS messages are directed to a CICS transient data queue. Language Environment splits messages to accommodate the record length of the destination, and presents messages in the correct national language such as Japanese or English.

- Supporting national languages

These services make it easy for your applications to support the language that application users want. You can set the language and country, and obtain default date, time, number, and currency formats. For example, you might want dates to appear as 23 June 09 or as 6,23,09.

- General services such as starting Debug Tool and obtaining a Language Environment formatted dump

Debug Tool provides advanced debugging functions for COBOL applications, including both batch and interactive debugging of CICS programs. Debug Tool enables you to debug a COBOL application from the host or, in conjunction with the Debug Perspective of Rational Developer for System z, from a Windows-based workstation.

Depending on the options that you select, the Language Environment formatted dump might contain the names and values of data items, and information about conditions, program tracebacks, control blocks, storage, and files. All Language Environment dumps have a common, well-labeled, easy-to-read format.

“Example: Language Environment callable services” on page 680

RELATED CONCEPTS

“Sample list of Language Environment callable services”

RELATED TASKS

“Using numeric intrinsic functions” on page 57

“Using math-oriented callable services” on page 59

“Using date callable services” on page 60

“Calling Language Environment services” on page 679

“Using procedure and function pointers” on page 487

Sample list of Language Environment callable services

The following table shows some examples of the callable services that are available with Language Environment. Many more services are available than those listed.

Table 91. Language Environment callable services

Function type	Service	Purpose
Condition handling	CEEHDLR	To register a user condition handler
	CEESGL	To raise or signal a condition
	CEEMRCR	To indicate where the program will resume running after the condition handler has finished
Dynamic storage	CEEGTST	To get storage
	CEECZST	To change the size of a previously allocated storage block
	CEEFRST	To free storage

Table 91. Language Environment callable services (continued)

Function type	Service	Purpose
Date and time	CEECBLDY	To convert a string that represents a date into COBOL integer date format, which represents a date as the number of days since 31 December 1600
	CEEQCEN, CEESCEN	To query and set the Language Environment century window, which is valuable when a program uses two digits to express a year
	CEEGMTO	To calculate the difference between the local system time and Greenwich Mean Time
	CEELOCT	To get the current local time in your choice of three formats
Math	CEESIABS	To calculate the absolute value of an integer
	CEESSNWN	To calculate the nearest whole number for a single-precision floating-point number
	CEESSCOS	To calculate the cosine of an angle
Message handling	CEEMOUT	To dispatch a message
	CEEMGET	To retrieve a message
National language support	CEE3LNG	To change or query the current national language
	CEE3CTY	To change or query the current national country
	CEE3MCS	To obtain the default currency symbol for a given country
General	CEE3DMP	To obtain a Language Environment formatted dump
	CEETEST	To start a debugging tool, such as Debug Tool

RELATED REFERENCES

Language Environment Programming Reference

Calling Language Environment services

To invoke a Language Environment service, use a CALL statement with the correct parameters for that service. Define the variables for the CALL statement in the DATA DIVISION with the definitions that are required by that service.

```

77 argument          comp-1.
77 feedback-code    pic x(12) display.
77 result           comp-1.
. . .
CALL "CEESSQT" using argument, feedback-code, result

```

In the example above, Language Environment service CEESSQT calculates the value of the square root of the variable argument and returns this value in the variable result.

You can choose whether to specify the feedback code parameter. If you specify it, the value returned in feedback-code indicates whether the service completed successfully. If you specify OMITTED instead of the feedback code, and the service is not successful, a Language Environment condition is automatically signaled to the Language Environment condition manager. You can handle such a condition by recovery logic implemented in a user-written condition handler, or let the default Language Environment processing for unhandled conditions occur. In either case, you avoid having to write logic to check the feedback code explicitly after each call.

If you call a Language Environment callable service and specify OMITTED for the feedback code, the RETURN-CODE special register is set to 0 if the service is successful. It is not altered if the service is unsuccessful. If you do not specify OMITTED for the feedback code, the RETURN-CODE special register is always set to 0 regardless of whether the service completed successfully.

“Example: Language Environment callable services”

RELATED CONCEPTS

Language Environment Programming Guide (General callable services)

RELATED REFERENCES

Language Environment Programming Reference (General callable services)

CALL statement (*Enterprise COBOL Language Reference*)

Example: Language Environment callable services

This example shows a COBOL program that uses the Language Environment services CEEDAYS and CEEDATE to format and display a date from the results of a COBOL ACCEPT statement.

Using CEEDAYS and CEEDATE reduces the coding that would be required without Language Environment.

```

ID DIVISION.
PROGRAM-ID. HOHOHO.
*****
* FUNCTION:  DISPLAY TODAY'S DATE IN THE FOLLOWING FORMAT: *
*           WWWWWWWW, MMMMMMM DD, YYYY                    *
*           *                                           *
*           For example: TUESDAY, SEPTEMBER 15, 2009      *
*           *                                           *
*****
ENVIRONMENT DIVISION.
DATA DIVISION.
WORKING-STORAGE SECTION.
01  CHRDATE.
    05 CHRDATE-LENGTH      PIC S9(4) COMP VALUE 10.
    05 CHRDATE-STRING      PIC X(10).
01  PICSTR.
    05 PICSTR-LENGTH        PIC S9(4) COMP.
    05 PICSTR-STRING        PIC X(80).
*
77  LILIAN PIC              S9(9) COMP.
77  FORMATTED-DATE          PIC X(80).
*
PROCEDURE DIVISION.
*****
*   USE LANGUAGE ENVIRONMENT CALLABLE SERVICES TO PRINT OUT *
*   TODAY'S DATE FROM COBOL ACCEPT STATEMENT.                *
*****
ACCEPT CHRDATE-STRING FROM DATE.
*
MOVE "YMMDD" TO PICSTR-STRING.
MOVE 6 TO PICSTR-LENGTH.
CALL "CEEDAYS" USING CHRDATE , PICSTR , LILIAN , OMITTED.
*
MOVE " WWWWWWWWZ, MMMMMMMZ DD, YYYY " TO PICSTR-STRING.
MOVE 50 TO PICSTR-LENGTH.
CALL "CEEDATE" USING LILIAN , PICSTR , FORMATTED-DATE ,
    OMITTED.
*
DISPLAY "*****".

```



```

DISPLAY FORMATTED-DATE.
DISPLAY "*****".
*
STOP RUN.

```

Using the format 2 SORT statement to sort a table

It is recommended to use the format 2 SORT statement to sort a table. It provides the following benefits when compared to the format 1 SORT statement.

Table 92. Comparison of format 1 and format 2 SORT statements

Characteristics	Format 1 SORT statements	Format 2 SORT statements
Can be used to sort a file or a table	Yes	No, it is for tables only
Requires DFSORT or equivalent sorting program	Yes	No
Supported in CICS	Limited	Yes
Supported in UNIX System Services	No	Yes
Supported in programs that are compiled with the THREAD option	No	Yes
Table can be sorted by using a single SORT statement, which simplifies coding	No, it requires the SELECT clauses, SD entries with record descriptions, and input and output procedures	Yes
Keys for sorting can be specified as part of the table definition, which can also be used in the SEARCH ALL statement	No, keys must be specified in the SORT statement. If the table is to be searched by using SEARCH ALL as well, the keys must also be redundantly specified as part of the table definition.	Yes, and it also supports specifying keys in the SORT statement if needed
Can filter or preprocess table elements during the sorting process	Yes, using input and output procedures	No, all of the table elements are passed to SORT as-is
Uses special registers that include SORT-CONTROL, SORT-CORE-SIZE, SORT-FILE-SIZE, SORT-MESSAGE, SORT-MODE-SIZE, and SORT-RETURN	Yes	No

Part 9. Appendixes

Appendix A. Intermediate results and arithmetic precision

The compiler handles arithmetic statements as a succession of operations performed according to operator precedence, and sets up intermediate fields to contain the results of those operations. The compiler uses algorithms to determine the number of integer and decimal places to reserve.

Intermediate results are possible in the following cases:

- In an ADD or SUBTRACT statement that contains more than one operand immediately after the verb
- In a COMPUTE statement that specifies a series of arithmetic operations or multiple result fields
- In an arithmetic expression contained in a conditional statement or in a reference-modification specification
- In an ADD, SUBTRACT, MULTIPLY, or DIVIDE statement that uses the GIVING option and multiple result fields
- In a statement that uses an intrinsic function as an operand
- In a statement that contains the ROUNDED phrase

“Example: calculation of intermediate results” on page 687

The precision of intermediate results depends on whether you compile using the default option ARITH(COMPAT) (referred to as *compatibility mode*) or using ARITH(EXTEND) (referred to as *extended mode*).

In compatibility mode, evaluation of arithmetic operations is unchanged from that in releases of IBM COBOL before COBOL for OS/390 & VM Version 2 Release 2:

- A maximum of 30 digits is used for fixed-point intermediate results.
- Floating-point intrinsic functions return long-precision (64-bit) floating-point results.
- Expressions that contain floating-point operands, fractional exponents, or floating-point intrinsic functions are evaluated as if all operands that are not in floating point are converted to long-precision floating point and floating-point operations are used to evaluate the expression.
- Floating-point literals and external floating-point data items are converted to long-precision floating point for processing.

In extended mode, evaluation of arithmetic operations has the following characteristics:

- A maximum of 31 digits is used for fixed-point intermediate results.
- Floating-point intrinsic functions return extended-precision (128-bit) floating-point results.
- Expressions that contain floating-point operands, fractional exponents, or floating-point intrinsic functions are evaluated as if all operands that are not in floating point are converted to extended-precision floating point and floating-point operations are used to evaluate the expression.
- Floating-point literals and external floating-point data items are converted to extended-precision floating point for processing.

RELATED CONCEPTS

"Formats for numeric data" on page 47

"Fixed-point contrasted with floating-point arithmetic" on page 62

RELATED REFERENCES

"Fixed-point data and intermediate results" on page 687

"Floating-point data and intermediate results" on page 692

"Arithmetic expressions in nonarithmetic statements" on page 693

"ARITH" on page 309

Terminology used for intermediate results

To understand this information about intermediate results, you need to understand the following terminology.

i The number of integer places carried for an intermediate result. (If you use the **ROUNDED** phrase, one more integer place might be carried for accuracy if necessary.)

d The number of decimal places carried for an intermediate result. (If you use the **ROUNDED** phrase, one more decimal place might be carried for accuracy if necessary.)

dmax In a particular statement, the largest of the following items:

- The number of decimal places needed for the final result field or fields
- The maximum number of decimal places defined for any operand, except divisors or exponents
- The *outer-dmax* for any function operand

inner-dmax

In reference to a function, the largest of the following items:

- The number of decimal places defined for any of its elementary arguments
- The *dmax* for any of its arithmetic expression arguments
- The *outer-dmax* for any of its embedded functions

outer-dmax

The number of decimal places that a function result contributes to operations outside of its own evaluation (for example, if the function is an operand in an arithmetic expression, or an argument to another function).

op1 The first operand in a generated arithmetic statement (in division, the divisor).

op2 The second operand in a generated arithmetic statement (in division, the dividend).

i1 , i2 The number of integer places in *op1* and *op2*, respectively.

d1 , d2

The number of decimal places in *op1* and *op2*, respectively.

ir The intermediate result when a generated arithmetic statement or operation is performed. (Intermediate results are generated either in registers or storage locations.)

ir1 , ir2

Successive intermediate results. (Successive intermediate results might have the same storage location.)

Example: calculation of intermediate results

The following example shows how the compiler performs an arithmetic statement as a succession of operations, storing intermediate results as needed.

```
COMPUTE Y = A + B * C - D / E + F ** G
```

The result is calculated in the following order:

1. Exponentiate F by G yielding *ir1*.
2. Multiply B by C yielding *ir2*.
3. Divide E into D yielding *ir3*.
4. Add A to *ir2* yielding *ir4*.
5. Subtract *ir3* from *ir4* yielding *ir5*.
6. Add *ir5* to *ir1* yielding Y.

RELATED TASKS

“Using arithmetic expressions” on page 57

RELATED REFERENCES

“Terminology used for intermediate results” on page 686

Fixed-point data and intermediate results

The compiler determines the number of integer and decimal places in an intermediate result.

Addition, subtraction, multiplication, and division

The following table shows the precision theoretically possible as the result of addition, subtraction, multiplication, or division.

Operation	Integer places	Decimal places
+ or -	$(i1 \text{ or } i2) + 1$, whichever is greater	$d1 \text{ or } d2$, whichever is greater
*	$i1 + i2$	$d1 + d2$
/	$i2 + d1$	$(d2 - d1)$ or $dmax$, whichever is greater

You must define the operands of any arithmetic statements with enough decimal places to obtain the accuracy you want in the final result.

The following table shows the number of places the compiler carries for fixed-point intermediate results of arithmetic operations that involve addition, subtraction, multiplication, or division in *compatibility mode* (that is, when the default compiler option ARITH(COMPAT) is in effect):

Value of $i + d$	Value of d	Value of $i + dmax$	Number of places carried for ir
<30 or =30	Any value	Any value	i integer and d decimal places

Value of $i + d$	Value of d	Value of $i + d_{max}$	Number of places carried for ir
>30	< d_{max} or = d_{max}	Any value	30- d integer and d decimal places
	> d_{max}	<30 or =30	i integer and 30- i decimal places
		>30	30- d_{max} integer and d_{max} decimal places

The following table shows the number of places the compiler carries for fixed-point intermediate results of arithmetic operations that involve addition, subtraction, multiplication, or division in *extended mode* (that is, when the compiler option ARITH(EXTEND) is in effect):

Value of $i + d$	Value of d	Value of $i + d_{max}$	Number of places carried for ir
<31 or =31	Any value	Any value	i integer and d decimal places
>31	< d_{max} or = d_{max}	Any value	31- d integer and d decimal places
	> d_{max}	<31 or =31	i integer and 31- i decimal places
		>31	31- d_{max} integer and d_{max} decimal places

Exponentiation

Exponentiation is represented by the expression $op1 ** op2$. Based on the characteristics of $op2$, the compiler handles exponentiation of fixed-point numbers in one of three ways:

- When $op2$ is expressed with decimals, floating-point instructions are used.
- When $op2$ is an integral literal or constant, the value d is computed as

$$d = d1 * |op2|$$

and the value i is computed based on the characteristics of $op1$:

- When $op1$ is a data-name or variable,
$$i = i1 * |op2|$$
- When $op1$ is a literal or constant, i is set equal to the number of integers in the value of $op1 ** |op2|$.

In compatibility mode (compilation using ARITH(COMPAT)), the compiler having calculated i and d takes the action indicated in the table below to handle the intermediate results ir of the exponentiation.

Value of $i + d$	Other conditions	Action taken
<30	Any	i integer and d decimal places are carried for ir .
=30	$op1$ has an odd number of digits.	i integer and d decimal places are carried for ir .
	$op1$ has an even number of digits.	Same action as when $op2$ is an integral data-name or variable (shown below). Exception: for a 30-digit integer raised to the power of literal 1, i integer and d decimal places are carried for ir .
>30	Any	Same action as when $op2$ is an integral data-name or variable (shown below)

In extended mode (compilation using ARITH(EXTEND)), the compiler having calculated i and d takes the action indicated in the table below to handle the intermediate results ir of the exponentiation.

Value of $i + d$	Other conditions	Action taken
<31	Any	i integer and d decimal places are carried for ir .
=31 or >31	Any	Same action as when $op2$ is an integral data-name or variable (shown below). Exception: for a 31-digit integer raised to the power of literal 1, i integer and d decimal places are carried for ir .

If $op2$ is negative, the value of 1 is then divided by the result produced by the preliminary computation. The values of i and d that are used are calculated following the division rules for fixed-point data already shown above.

- When $op2$ is an integral data-name or variable, $dmax$ decimal places and $30-dmax$ (compatibility mode) or $31-dmax$ (extended mode) integer places are used. $op1$ is multiplied by itself ($|op2| - 1$) times for nonzero $op2$.

If $op2$ is equal to 0, the result is 1. Division-by-0 and exponentiation SIZE ERROR conditions apply.

Fixed-point exponents with more than nine significant digits are always truncated to nine digits. If the exponent is a literal or constant, an E-level compiler diagnostic message is issued; otherwise, an informational message is issued at run time.

“Example: exponentiation in fixed-point arithmetic”

RELATED REFERENCES

“Terminology used for intermediate results” on page 686

“Truncated intermediate results” on page 690

“Binary data and intermediate results” on page 690

“Floating-point data and intermediate results” on page 692

“Intrinsic functions evaluated in fixed-point arithmetic” on page 690

“ARITH” on page 309

SIZE ERROR phrases (*Enterprise COBOL Language Reference*)

Example: exponentiation in fixed-point arithmetic

The following example shows how the compiler performs an exponentiation to a nonzero integer power as a succession of multiplications, storing intermediate results as needed.

```
COMPUTE Y = A ** B
```

If B is equal to 4, the result is computed as shown below. The values of i and d that are used are calculated according to the multiplication rules for fixed-point data and intermediate results (referred to below).

1. Multiply A by A yielding an internal intermediate result $iir1$.
2. Multiply $iir1$ by A yielding an internal intermediate result $iir2$.
3. Multiply $iir2$ by A yielding an internal intermediate result $iir3$.
4. Move $iir3$ to $ir4$.

$ir4$ has $dmax$ decimal places. Because B is positive, $ir4$ is moved to Y. If B were equal to -4, however, an additional fifth step would be performed:

5. Divide $ir4$ into 1 yielding $ir5$.

$ir5$ has $dmax$ decimal places, and would then be moved to Y.

| **Note:** The internal intermediate results (*iir1*, *iir2*, and *iir3*) obtained by the internal
| library routine performing the exponential calculation in steps 1, 2, and 3 above do
| not use the same decimal precision as *ir4* and *ir5* above. Instead, those
| intermediate results are much more precise, ensuring the most accurate result
| possible in *ir4* or *ir5*.

RELATED REFERENCES

“Terminology used for intermediate results” on page 686

“Fixed-point data and intermediate results” on page 687

Truncated intermediate results

Whenever the number of digits in an intermediate result exceeds 30 in compatibility mode or 31 in extended mode, the compiler truncates to 30 (compatibility mode) or 31 (extended mode) digits and issues a warning. If truncation occurs at run time, a message is issued and the program continues running.

If you want to avoid the truncation of intermediate results that can occur in fixed-point calculations, use floating-point operands (COMP-1 or COMP-2) instead.

RELATED CONCEPTS

“Formats for numeric data” on page 47

RELATED REFERENCES

“Fixed-point data and intermediate results” on page 687

“ARITH” on page 309

Binary data and intermediate results

If an operation that involves binary operands requires intermediate results longer than 18 digits, the compiler converts the operands to internal decimal before performing the operation. If the result field is binary, the compiler converts the result from internal decimal to binary.

Binary operands are most efficient when intermediate results will not exceed nine digits.

RELATED REFERENCES

“Fixed-point data and intermediate results” on page 687

“ARITH” on page 309

Intrinsic functions evaluated in fixed-point arithmetic

The compiler determines the *inner-dmax* and *outer-dmax* values for an intrinsic function from the characteristics of the function.

Integer functions

Integer intrinsic functions return an integer; thus their *outer-dmax* is always zero. For those integer functions whose arguments must all be integers, the *inner-dmax* is thus also always zero.

The following table summarizes the *inner-dmax* and the precision of the function result.

Function	<i>Inner-dmax</i>	Digit precision of function result
DATE-OF-INTEGER	0	8
DATE-TO-YYYYMMDD	0	8
DAY-OF-INTEGER	0	7
DAY-TO-YYYYDDD	0	7
FACTORIAL	0	30 in compatibility mode, 31 in extended mode
INTEGER-OF-DATE	0	7
INTEGER-OF-DAY	0	7
LENGTH	n/a	9
MOD	0	$\min(i1\ i2)$
ORD	n/a	3
ORD-MAX		9
ORD-MIN		9
YEAR-TO-YYYY	0	4
INTEGER		For a fixed-point argument: one more digit than in the argument. For a floating-point argument: 30 in compatibility mode, 31 in extended mode.
INTEGER-PART		For a fixed-point argument: same number of digits as in the argument. For a floating-point argument: 30 in compatibility mode, 31 in extended mode.

Mixed functions

A *mixed* intrinsic function is a function whose result type depends on the type of its arguments. A mixed function is fixed point if all of its arguments are numeric and none of its arguments is floating point. (If any argument of a mixed function is floating point, the function is evaluated with floating-point instructions and returns a floating-point result.) When a mixed function is evaluated with fixed-point arithmetic, the result is integer if all of the arguments are integer; otherwise, the result is fixed point.

For the mixed functions MAX, MIN, RANGE, REM, and SUM, the *outer-dmax* is always equal to the *inner-dmax* (and both are thus zero if all the arguments are integer). To determine the precision of the result returned for these functions, apply the rules for fixed-point arithmetic and intermediate results (as referred to below) to each step in the algorithm.

MAX

1. Assign the first argument to the function result.
2. For each remaining argument, do the following steps:
 - a. Compare the algebraic value of the function result with the argument.
 - b. Assign the greater of the two to the function result.

MIN

1. Assign the first argument to the function result.
2. For each remaining argument, do the following steps:
 - a. Compare the algebraic value of the function result with the argument.
 - b. Assign the lesser of the two to the function result.

RANGE

1. Use the steps for MAX to select the maximum argument.
2. Use the steps for MIN to select the minimum argument.
3. Subtract the minimum argument from the maximum.
4. Assign the difference to the function result.

REM

1. Divide argument one by argument two.
2. Remove all noninteger digits from the result of step 1.
3. Multiply the result of step 2 by argument two.
4. Subtract the result of step 3 from argument one.
5. Assign the difference to the function result.

SUM

1. Assign the value 0 to the function result.
2. For each argument, do the following steps:
 - a. Add the argument to the function result.
 - b. Assign the sum to the function result.

RELATED REFERENCES

“Terminology used for intermediate results” on page 686

“Fixed-point data and intermediate results” on page 687

“Floating-point data and intermediate results”

“ARITH” on page 309

Floating-point data and intermediate results

If any operation in an arithmetic expression is computed in floating-point arithmetic, the entire expression is computed as if all operands were converted to floating point and the operations were performed using floating-point instructions.

Floating-point instructions are used to compute an arithmetic expression if any of the following conditions is true of the expression:

- A receiver or operand is COMP-1, COMP-2, external floating point, or a floating-point literal.
- An exponent contains decimal places.
- An exponent is an expression that contains an exponentiation or division operator, and *dmax* is greater than zero.
- An intrinsic function is a floating-point function.

In compatibility mode, if an expression is computed in floating-point arithmetic, the precision used to evaluate the arithmetic operations is determined as follows:

- Single precision is used if all receivers and operands are COMP-1 data items and the expression contains no multiplication or exponentiation operations.
- In all other cases, long precision is used.

Whenever long-precision floating point is used for one operation in an arithmetic expression, all operations in the expression are computed as if long floating-point instructions were used.

In extended mode, if an expression is computed in floating-point arithmetic, the precision used to evaluate the arithmetic operations is determined as follows:

- Single precision is used if all receivers and operands are COMP-1 data items and the expression contains no multiplication or exponentiation operations.
- Long precision is used if all receivers and operands are COMP-1 or COMP-2 data items, at least one receiver or operand is a COMP-2 data item, and the expression contains no multiplication or exponentiation operations.
- In all other cases, extended precision is used.

Whenever extended-precision floating point is used for one operation in an arithmetic expression, all operations in the expression are computed as if extended-precision floating-point instructions were used.

Alert: If a floating-point operation has an intermediate result field in which exponent overflow occurs, the job is abnormally terminated.

Exponentiations evaluated in floating-point arithmetic

In compatibility mode, floating-point exponentiations are always evaluated using long floating-point arithmetic. In extended mode, floating-point exponentiations are always evaluated using extended-precision floating-point arithmetic.

The value of a negative number raised to a fractional power is undefined in COBOL. For example, $(-2)^3$ is equal to -8, but $(-2)^{3.000001}$ is undefined. When an exponentiation is evaluated in floating point and there is a possibility that the result is undefined, the exponent is evaluated at run time to determine if it has an integral value. If not, a diagnostic message is issued.

Intrinsic functions evaluated in floating-point arithmetic

In compatibility mode, floating-point intrinsic functions always return a long (64-bit) floating-point value. In extended mode, floating-point intrinsic functions always return an extended-precision (128-bit) floating-point value.

Mixed functions that have at least one floating-point argument are evaluated using floating-point arithmetic.

RELATED REFERENCES

“Terminology used for intermediate results” on page 686
 “ARITH” on page 309

Arithmetic expressions in nonarithmetic statements

Arithmetic expressions can appear in contexts other than arithmetic statements. For example, you can use an arithmetic expression with the IF or EVALUATE statement.

In such statements, the rules for intermediate results with fixed-point data and for intermediate results with floating-point data apply, with the following changes:

- Abbreviated IF statements are handled as though the statements were not abbreviated.
- In an explicit relation condition where at least one of the comparands is an arithmetic expression, *dmax* is the maximum number of decimal places for any operand of either comparand, excluding divisors and exponents. The rules for floating-point arithmetic apply if any of the following conditions is true:
 - Any operand in either comparand is COMP-1, COMP-2, external floating point, or a floating-point literal.
 - An exponent contains decimal places.

- An exponent is an expression that contains an exponentiation or division operator, and *dmax* is greater than zero.

For example:

```
IF operand-1 = expression-1 THEN . . .
```

If *operand-1* is a data-name defined to be COMP-2, the rules for floating-point arithmetic apply to *expression-1* even if it contains only fixed-point operands, because it is being compared to a floating-point operand.

- When the comparison between an arithmetic expression and another data item or arithmetic expression does not use a relational operator (that is, there is no explicit relation condition), the arithmetic expression is evaluated without regard to the attributes of its comparand. For example:

```
EVALUATE expression-1  
  WHEN expression-2 THRU expression-3  
  WHEN expression-4  
  . . .  
END-EVALUATE
```

In the statement above, each arithmetic expression is evaluated in fixed-point or floating-point arithmetic based on its own characteristics.

RELATED CONCEPTS

“Fixed-point contrasted with floating-point arithmetic” on page 62

RELATED REFERENCES

“Terminology used for intermediate results” on page 686

“Fixed-point data and intermediate results” on page 687

“Floating-point data and intermediate results” on page 692

IF statement (*Enterprise COBOL Language Reference*)

EVALUATE statement (*Enterprise COBOL Language Reference*)

Conditional expressions (*Enterprise COBOL Language Reference*)

Appendix B. Converting double-byte character set (DBCS) data

The Language Environment service routines IGZCA2D and IGZCD2A were intended for converting alphanumeric data items that contain DBCS data to and from pure DBCS data items in order to reliably perform operations such as STRING, UNSTRING, and reference modification.

These service routines continue to be provided for compatibility; however, using national data items and the national conversion operations is now recommended instead for this purpose.

The service routines do not support a code-page argument and are not sensitive to the code page specified by the CODEPAGE compiler option. The DBCS compiler option does not affect their operation.

RELATED TASKS

“Converting to or from national (Unicode) representation” on page 137

“Processing alphanumeric data items that contain DBCS data” on page 152

RELATED REFERENCES

“DBCS notation”

“Alphanumeric to DBCS data conversion (IGZCA2D)”

“DBCS to alphanumeric data conversion (IGZCD2A)” on page 698

“CODEPAGE” on page 313

DBCS notation

The symbols shown below are used in the DBCS data conversion examples to describe DBCS items.

Symbols	Meaning
< and >	Shift-out (SO) and shift-in (SI), respectively
D0, D1, D2, . . . , Dn	Any DBCS character except for double-byte EBCDIC characters that correspond to single-byte EBCDIC characters
.A, .B, .C, . . .	Any double-byte EBCDIC character that corresponds to a single-byte EBCDIC character. The period (.) represents the value X'42'.
A single letter, such as A, B, or s	Any single-byte EBCDIC character

Alphanumeric to DBCS data conversion (IGZCA2D)

The Language Environment IGZCA2D service routine converts alphanumeric data that contains double-byte characters to pure DBCS data.

IGZCA2D syntax

To use the IGZCA2D service routine, pass the following four parameters to the routine by using the CALL statement:

parameter-1

The sending field for the conversion, handled as an alphanumeric data item.

parameter-2

The receiving field for the conversion, handled as a DBCS data item.

You cannot use reference modification with *parameter-2*.

parameter-3

The number of bytes in *parameter-1* to be converted.

It can be the LENGTH OF special register of *parameter-1*, or a 4-byte USAGE IS BINARY data item containing the number of bytes of *parameter-1* to be converted. Shift codes count as 1 byte each.

parameter-4

The number of bytes in *parameter-2* that will receive the converted data.

It can be the LENGTH OF special register of *parameter-2*, or a 4-byte USAGE IS BINARY data item containing the number of bytes of *parameter-2* to receive the converted data.

Usage notes

- You can pass *parameter-1*, *parameter-3*, and *parameter-4* to the routine BY REFERENCE or BY CONTENT, but you must pass *parameter-2* BY REFERENCE.
- The compiler does not perform syntax checking on these parameters. Ensure that the parameters are correctly set and passed in the CALL statement to the conversion routine. Otherwise, results are unpredictable.
- When creating *parameter-2* from *parameter-1*, IGZCA2D makes these changes:
 - Removes the shift codes, leaving the DBCS data unchanged
 - Converts the single-byte (nonspace) EBCDIC character X'*nm*' to a character represented by X'42*nm*'
 - Converts the single-byte space (X'40') to DBCS space (X'4040'), instead of X'4240'
- IGZCA2D does not change the contents of *parameter-1*, *parameter-3*, or *parameter-4*.
- The valid range for the contents of *parameter-3* and for the contents of *parameter-4* is 1 to 134,217,727.

“Example: IGZCA2D” on page 697

RELATED REFERENCES

“IGZCA2D return codes”

IGZCA2D return codes

IGZCA2D sets the RETURN-CODE special register to reflect the status of the conversion.

Table 93. IGZCA2D return codes

Return code	Explanation
0	<i>parameter-1</i> was converted and the results were placed in <i>parameter-2</i> .
2	<i>parameter-1</i> was converted and the results were placed in <i>parameter-2</i> . <i>parameter-2</i> was padded on the right with DBCS spaces.
4	<i>parameter-1</i> was converted and the results were placed in <i>parameter-2</i> . The DBCS data placed in <i>parameter-2</i> was truncated on the right.

Table 93. IGZCA2D return codes (continued)

Return code	Explanation
6	<i>parameter-1</i> was converted and the results were placed in <i>parameter-2</i> . A single-byte character in the range X'00' to X'3F' or X'FF' was encountered. The valid single-byte character was converted into an out-of-range DBCS character.
8	<i>parameter-1</i> was converted and the results were placed in <i>parameter-2</i> . A single-byte character in the range X'00' to X'3F' or X'FF' was encountered. The valid single-byte character was converted into an out-of-range DBCS character. <i>parameter-2</i> was padded on the right with DBCS spaces.
10	<i>parameter-1</i> was converted and the results were placed in <i>parameter-2</i> . A single-byte character in the range X'00' to X'3F' or X'FF' was encountered. The valid single-byte character was converted into an out-of-range DBCS character. The DBCS data in <i>parameter-2</i> was truncated on the right.
12	An odd number of bytes was found between paired shift codes in <i>parameter-1</i> . No conversion occurred.
13	Unpaired or nested shift codes were found in <i>parameter-1</i> . No conversion occurred.
14	<i>parameter-1</i> and <i>parameter-2</i> were overlapping. No conversion occurred.
15	The value provided for <i>parameter-3</i> or <i>parameter-4</i> was out of range. No conversion occurred.
16	An odd number of bytes was coded in <i>parameter-4</i> . No conversion occurred.

Example: IGZCA2D

This example CALL statement converts the alphanumeric data in *alpha-item* to DBCS data. The results of the conversion are placed in *dbcs-item*.

```
CALL "IGZCA2D" USING BY REFERENCE alpha-item dbc-item
    BY CONTENT LENGTH OF alpha-item LENGTH OF dbc-item
```

Suppose the contents of *alpha-item* and *dbcs-item* and the lengths before the conversion are:

```
alpha-item = AB<D1D2D3>CD
dbcs-item  = D4D5D6D7D8D9D0
LENGTH OF alpha-item = 12
LENGTH OF dbc-item   = 14
```

Then after the conversion, *alpha-item* and *dbcs-item* will contain:

```
alpha-item = AB<D1D2D3>CD
dbcs-item  = .A.BD1D2D3.C.D
```

The content of the RETURN-CODE register is 0.

RELATED REFERENCES

"DBCS notation" on page 695

DBCS to alphanumeric data conversion (IGZCD2A)

The Language Environment IGZCD2A routine converts pure DBCS data to alphanumeric data that can contain double-byte characters.

IGZCD2A syntax

To use the IGZCD2A service routine, pass the following four parameters to the routine using the CALL statement:

parameter-1

The sending field for the conversion, handled as a DBCS data item.

parameter-2

The receiving field for the conversion, handled as an alphanumeric data item.

parameter-3

The number of bytes in *parameter-1* to be converted.

It can be the LENGTH OF special register of *parameter-1*, or a 4-byte USAGE IS BINARY data item containing the number of bytes of *parameter-1* to be converted.

parameter-4

The number of bytes in *parameter-2* that will receive the converted data.

It can be the LENGTH OF special register of *parameter-2*, or a 4-byte USAGE IS BINARY data item containing the number of bytes of *parameter-2* to receive the converted data. Shift codes count as 1 byte each.

Usage notes

- You can pass *parameter-1*, *parameter-3*, and *parameter-4* to the routine BY REFERENCE or BY CONTENT, but you must pass *parameter-2* BY REFERENCE.
- The compiler does not perform syntax checking on these parameters. Ensure that the parameters are correctly set and passed to the conversion routine. Otherwise, results are unpredictable.
- When creating *parameter-2* from *parameter-1*, IGZCD2A makes these changes:
 - Inserts shift codes around DBCS characters that do not correspond to single-byte EBCDIC characters
 - Converts DBCS characters to single-byte characters when the DBCS characters correspond to single-byte EBCDIC characters
 - Converts the DBCS space (X'4040') to a single-byte space (X'40')
- IGZCD2A does not change the contents of *parameter-1*, *parameter-3*, or *parameter-4*.
- If the converted data contains double-byte characters, shift codes are counted in the length of *parameter-2*.
- The valid range for the contents of *parameter-3* and for the contents of *parameter-4* is 1 to 134,217,727.

“Example: IGZCD2A” on page 699

RELATED REFERENCES

“IGZCD2A return codes” on page 699

IGZCD2A return codes

IGZCD2A sets the RETURN-CODE special register to reflect the status of the conversion.

Table 94. IGZCD2A return codes

Return code	Explanation
0	<i>parameter-1</i> was converted and the results were placed in <i>parameter-2</i> .
2	<i>parameter-1</i> was converted and the results were placed in <i>parameter-2</i> . <i>parameter-2</i> was padded on the right with single-byte spaces.
4	<i>parameter-1</i> was converted and the results were placed in <i>parameter-2</i> . <i>parameter-2</i> was truncated on the right. ¹
14	<i>parameter-1</i> and <i>parameter-2</i> were overlapping. No conversion occurred.
15	The value of <i>parameter-3</i> or <i>parameter-4</i> was out of range. No conversion occurred.
16	An odd number of bytes was coded in <i>parameter-3</i> . No conversion occurred.
1. If a truncation occurs within the DBCS characters, the truncation is on an even-byte boundary and a shift-in (SI) is inserted. If necessary, the alphanumeric data is padded with a single-byte space after the shift-in.	

Example: IGZCD2A

This example CALL statement converts the DBCS data in *dbcs-item* to alphanumeric data with double-byte characters. The results of the conversion are placed in *alpha-item*.

```
CALL "IGZCD2A" USING BY REFERENCE dbcs-item alpha-item  
BY CONTENT LENGTH OF dbcs-item LENGTH OF alpha-item
```

Suppose the contents of *dbcs-item* and *alpha-item* and the lengths before the conversion are:

```
dbcs-item = .A.BD1D2D3.C.D  
alpha-item = ssssssssss  
LENGTH OF dbcs-item = 14  
LENGTH OF alpha-item = 12
```

Then after the conversion, *dbcs-item* and *alpha-item* will contain:

```
dbcs-item = .A.BD1D2D3.C.D  
alpha-item = AB<D1D2D3>CD
```

The content of the RETURN-CODE register is 0.

RELATED REFERENCES

"DBCS notation" on page 695

Appendix C. XML reference material

The following information describes the XML exception codes that might be returned during XML parsing or XML generation.

RELATED REFERENCES

“XML PARSE exceptions with XMLPARSE(XMLSS) in effect”

“XML PARSE exceptions with XMLPARSE(COMPAT) in effect” on page 703

“XML GENERATE exceptions” on page 710

XML specification

XML PARSE exceptions with XMLPARSE(XMLSS) in effect

When the z/OS XML System Services parser passes control to your processing procedure for an exception event, the XML-CODE special register contains the exception code, which is formed from a return code and a reason code.

The return code and reason code are each a halfword binary value. The exception code is the concatenation of those two values: the return code in the high-order halfword, and the reason code in the low-order halfword.

The return codes and reason codes are documented as hexadecimal values in the *z/OS XML System Services User's Guide and Reference*, referenced below, and in Table 95 on page 702 below.

After most exception events, the parser does not continue processing; the value in XML-CODE at the end of the XML PARSE statement is the original exception code set by the parser.

When the processing procedure returns to the parser after the exception event, control transfers to the statement specified in the ON EXCEPTION phrase, or to the end of the XML PARSE statement if you did not code an ON EXCEPTION phrase.

Validation exceptions:

If you code an XML PARSE statement that contains the VALIDATING phrase, and the z/OS XML System Services parser determines that the document is not valid, the parser generates return code 24 (hexadecimal 18, XRC_NOT_VALID).

Exceptions that are unique to Enterprise COBOL:

Some exceptions are unique to Enterprise COBOL and thus are not documented in the *z/OS XML System Services User's Guide and Reference*, for example, errors that occur during XML schema retrieval. The return code for exceptions with reason codes in the hexadecimal range 800 to 899 is 4 (hexadecimal 0004, XRC_WARNING). For other exceptions, the return code is 16 (hexadecimal 0010, XRC_FATAL). The exception code (the value in special register XML-CODE), is formed from this return code concatenated with one of the reason codes shown in the following table.

Table 95. Reason codes for XML PARSE exceptions that are unique to Enterprise COBOL

Reason code (hexadecimal)	Description
700	VALIDATING WITH FILE is not supported under CICS.
701	The optimized XML schema that was read in was too short, or the file was empty.
702	The file identifier for the schema was not a ddname or environment-variable name.
703	The DSN value contained a space character in a position where a space is not allowed.
704	The DSN value specified a temporary data set.
705	The PATH value contained an unescaped space character.
706	The PATH value contained a path name that was not an absolute path.
707	Memory allocation for the XML schema buffer failed.
708	The environment variable was null or contained only spaces.
709	The environment variable contained an invalid keyword.
710	The DSN value contained an invalid character after the member name.
711	The DSN value did not specify a member name.
712	The DSN value did not specify a data set name, or parentheses were not specified correctly.
713	The PATH value did not specify a path name, or parentheses were not specified correctly.
714	The DSN value contained an extra parenthesis.
715	The PATH value contained an extra parenthesis.
716	The DSN value was missing the closing parenthesis.
717	The PATH value was missing the closing parenthesis.
718	The DSN value contained an escape character.
720	A character reference for an unrepresentable character was not resolved.
721	An unrepresentable character reference in the document type declaration is not supported.
800	The attribute name used an undeclared prefix.
801	The START-OF-ELEMENT name used an undeclared prefix. (The END-OF-ELEMENT name must match, so using the same undeclared prefix does not cause another exception.)
900	Internal error. Report the error to your service representative.

For any of the reason codes except 900, correct the error and then retry your program.

RELATED CONCEPTS

“XML-CODE” on page 535
 “XML events” on page 534

RELATED TASKS

“Handling XML PARSE exceptions” on page 552

RELATED REFERENCES

"XMLPARSE" on page 373 (compiler option)
XML PARSE statement (*Enterprise COBOL Language Reference*)
z/OS XML System Services User's Guide and Reference

XML PARSE exceptions with XMLPARSE(COMPAT) in effect

When an exception event occurs, the XML parser that is provided with the Enterprise COBOL library sets special register XML-CODE to a value that identifies the exception. Depending on the value in XML-CODE, the parser might or might not be able to continue processing after the exception, as detailed in the information referenced below.

RELATED REFERENCES

"XML PARSE exceptions that allow continuation"
"XML PARSE exceptions that do not allow continuation" on page 707

XML PARSE exceptions that allow continuation

If the XMLPARSE(COMPAT) compiler option is in effect, whether the XML parser can continue processing after an exception event depends upon the value of the exception code.

The parser can continue processing if the exception code, which is in special register XML-CODE, is within one of the following ranges:

- 1 - 99
- 100,001 - 165,535

The following table describes each exception, and identifies the actions that the parser takes if you request that it continue after the exception. Some of the descriptions use the following terms:

- *Actual document encoding*
- *Document encoding declaration*

For definitions of the terms, see the related concept about XML input document encoding.

Table 96. XML PARSE exceptions that allow continuation

Exception code (decimal)	Description	Parser action on continuation
1	The parser found an invalid character while scanning white space outside element content. For further information about white space, see the related concept about XML input document encoding.	The parser continues detecting errors until it reaches the end of the document or encounters an error that does not allow continuation. The parser does not signal any further normal events, except for the END-OF-DOCUMENT event.
2	The parser found an invalid start of a processing instruction, element, comment, or document type declaration outside element content.	The parser continues detecting errors until it reaches the end of the document or encounters an error that does not allow continuation. The parser does not signal any further normal events, except for the END-OF-DOCUMENT event.

Table 96. XML PARSE exceptions that allow continuation (continued)

Exception code (decimal)	Description	Parser action on continuation
3	The parser found a duplicate attribute name.	The parser continues detecting errors until it reaches the end of the document or encounters an error that does not allow continuation. The parser does not signal any further normal events, except for the END-OF-DOCUMENT event.
4	The parser found the markup character '<' in an attribute value.	The parser continues detecting errors until it reaches the end of the document or encounters an error that does not allow continuation. The parser does not signal any further normal events, except for the END-OF-DOCUMENT event.
5	The start and end tag names of an element did not match.	The parser continues detecting errors until it reaches the end of the document or encounters an error that does not allow continuation. The parser does not signal any further normal events, except for the END-OF-DOCUMENT event.
6	The parser found an invalid character in element content.	The parser continues detecting errors until it reaches the end of the document or encounters an error that does not allow continuation. The parser does not signal any further normal events, except for the END-OF-DOCUMENT event.
7	The parser found an invalid start of an element, comment, processing instruction, or CDATA section in element content.	The parser continues detecting errors until it reaches the end of the document or encounters an error that does not allow continuation. The parser does not signal any further normal events, except for the END-OF-DOCUMENT event.
8	The parser found in element content the CDATA closing character sequence ']]>' without the matching opening character sequence '<![CDATA['.	The parser continues detecting errors until it reaches the end of the document or encounters an error that does not allow continuation. The parser does not signal any further normal events, except for the END-OF-DOCUMENT event.
9	The parser found an invalid character in a comment.	The parser continues detecting errors until it reaches the end of the document or encounters an error that does not allow continuation. The parser does not signal any further normal events, except for the END-OF-DOCUMENT event.
10	The parser found in a comment the character sequence '--' (two hyphens) not followed by '>'.	The parser continues detecting errors until it reaches the end of the document or encounters an error that does not allow continuation. The parser does not signal any further normal events, except for the END-OF-DOCUMENT event.

Table 96. XML PARSE exceptions that allow continuation (continued)

Exception code (decimal)	Description	Parser action on continuation
11	The parser found an invalid character in a processing instruction data segment.	The parser continues detecting errors until it reaches the end of the document or encounters an error that does not allow continuation. The parser does not signal any further normal events, except for the END-OF-DOCUMENT event.
12	The XML declaration was not at the beginning of the document.	The parser continues detecting errors until it reaches the end of the document or encounters an error that does not allow continuation. The parser does not signal any further normal events, except for the END-OF-DOCUMENT event.
13	The parser found an invalid digit in a hexadecimal character reference (of the form <code>&#xddd;</code>).	The parser continues detecting errors until it reaches the end of the document or encounters an error that does not allow continuation. The parser does not signal any further normal events, except for the END-OF-DOCUMENT event.
14	The parser found an invalid digit in a decimal character reference (of the form <code>&#ddd;</code>).	The parser continues detecting errors until it reaches the end of the document or encounters an error that does not allow continuation. The parser does not signal any further normal events, except for the END-OF-DOCUMENT event.
15	The encoding declaration value in the XML declaration did not begin with lowercase or uppercase A through Z.	The parser continues detecting errors until it reaches the end of the document or encounters an error that does not allow continuation. The parser does not signal any further normal events, except for the END-OF-DOCUMENT event.
16	A character reference did not refer to a legal XML character.	The parser continues detecting errors until it reaches the end of the document or encounters an error that does not allow continuation. The parser does not signal any further normal events, except for the END-OF-DOCUMENT event.
17	The parser found an invalid character in an entity reference name.	The parser continues detecting errors until it reaches the end of the document or encounters an error that does not allow continuation. The parser does not signal any further normal events, except for the END-OF-DOCUMENT event.
18	The parser found an invalid character in an attribute value.	The parser continues detecting errors until it reaches the end of the document or encounters an error that does not allow continuation. The parser does not signal any further normal events, except for the END-OF-DOCUMENT event.

Table 96. XML PARSE exceptions that allow continuation (continued)

Exception code (decimal)	Description	Parser action on continuation
70	The actual document encoding was EBCDIC, and the CODEPAGE compiler option specified a supported EBCDIC code page, but the document encoding declaration did not specify a supported EBCDIC code page.	The parser uses the encoding specified by the CODEPAGE compiler option.
71	The actual document encoding was EBCDIC, and the document encoding declaration specified a supported EBCDIC encoding, but the CODEPAGE compiler option did not specify a supported EBCDIC code page.	The parser uses the encoding specified by the document encoding declaration.
72	The actual document encoding was EBCDIC, the CODEPAGE compiler option did not specify a supported EBCDIC code page, and the document did not contain an encoding declaration.	The parser uses EBCDIC code page 1140 (USA, Canada, . . . Euro Country Extended Code Page).
73	The actual document encoding was EBCDIC, but neither the CODEPAGE compiler option nor the document encoding declaration specified a supported EBCDIC code page.	The parser uses EBCDIC code page 1140 (USA, Canada, . . . Euro Country Extended Code Page).
82	The actual document encoding was ASCII, but the document did not contain an encoding declaration.	The parser uses ASCII code page 819 (ISO-8859-1 Latin 1/Open Systems).
83	The actual document encoding was ASCII, but the document encoding declaration did not specify code page 813, 819, or 920.	The parser uses ASCII code page 819 (ISO-8859-1 Latin 1/Open Systems).
92	The document data item was alphanumeric, but the actual document encoding was Unicode UTF-16.	The parser uses code page 1200 (Unicode UTF-16).
100,001 - 165,535	The CODEPAGE compiler option and the document encoding declaration specified different supported EBCDIC code pages. XML-CODE contains the code page CCSID for the encoding declaration plus 100,000.	If you set XML-CODE to zero before returning from the EXCEPTION event, the parser uses the encoding specified by the CODEPAGE compiler option. If you set XML-CODE to the CCSID for the document encoding declaration (by subtracting 100,000), the parser uses this encoding.

RELATED CONCEPTS

“XML-CODE” on page 535

“XML input document encoding” on page 547

RELATED TASKS

“Handling XML PARSE exceptions” on page 552

RELATED REFERENCES

“XMLPARSE” on page 373 (compiler option)

XML PARSE exceptions that do not allow continuation

If the XMLPARSE(COMPAT) compiler option is in effect, the XML parser cannot continue processing if any of the exceptions described below occurs.

No further events are returned from the parser for any of these exceptions even if the processing procedure sets XML-CODE to zero before passing control back to the parser. The parser transfers control to the statement in the ON EXCEPTION phrase, if specified, otherwise to the end of the XML PARSE statement.

Table 97. XML PARSE exceptions that do not allow continuation (for XMLPARSE(COMPAT))

Exception code (decimal)	Description
100	The parser reached the end of the document while scanning the start of the XML declaration.
101	The parser reached the end of the document while looking for the end of the XML declaration.
102	The parser reached the end of the document while looking for the root element.
103	The parser reached the end of the document while looking for the version information in the XML declaration.
104	The parser reached the end of the document while looking for the version information value in the XML declaration.
106	The parser reached the end of the document while looking for the encoding declaration value in the XML declaration.
108	The parser reached the end of the document while looking for the standalone declaration value in the XML declaration.
109	The parser reached the end of the document while scanning an attribute name.
110	The parser reached the end of the document while scanning an attribute value.
111	The parser reached the end of the document while scanning a character reference or entity reference in an attribute value.
112	The parser reached the end of the document while scanning an empty element tag.
113	The parser reached the end of the document while scanning the root element name.
114	The parser reached the end of the document while scanning an element name.
115	The parser reached the end of the document while scanning character data in element content.

Table 97. XML PARSE exceptions that do not allow continuation (for XMLPARSE (COMPAT)) (continued)

Exception code (decimal)	Description
116	The parser reached the end of the document while scanning a processing instruction in element content.
117	The parser reached the end of the document while scanning a comment or CDATA section in element content.
118	The parser reached the end of the document while scanning a comment in element content.
119	The parser reached the end of the document while scanning a CDATA section in element content.
120	The parser reached the end of the document while scanning a character reference or entity reference in element content.
121	The parser reached the end of the document while scanning after the close of the root element.
122	The parser found a possible invalid start of a document type declaration.
123	The parser found a second document type declaration.
124	The first character of the root element name was not a letter, '_', or ':'.
125	The first character of the first attribute name of an element was not a letter, '_', or ':'.
126	The parser found an invalid character either in or following an element name.
127	The parser found a character other than '=' following an attribute name.
128	The parser found an invalid attribute value delimiter.
130	The first character of an attribute name was not a letter, '_', or ':'.
131	The parser found an invalid character either in or following an attribute name.
132	An empty element tag was not terminated by a '>' following the '/'.
133	The first character of an element end tag name was not a letter, '_', or ':'.
134	An element end tag name was not terminated by a '>'.
135	The first character of an element name was not a letter, '_', or ':'.
136	The parser found an invalid start of a comment or CDATA section in element content.
137	The parser found an invalid start of a comment.
138	The first character of a processing instruction target name was not a letter, '_', or ':'.
139	The parser found an invalid character in or following a processing instruction target name.
140	A processing instruction was not terminated by the closing character sequence '?>'.
141	The parser found an invalid character following '&' in a character reference or entity reference.
142	The version information was not present in the XML declaration.
143	'version' in the XML declaration was not followed by '='.
144	The version declaration value in the XML declaration is either missing or improperly delimited.

Table 97. XML PARSE exceptions that do not allow continuation (for XMLPARSE (COMPAT)) (continued)

Exception code (decimal)	Description
145	The version information value in the XML declaration specified a bad character, or the start and end delimiters did not match.
146	The parser found an invalid character following the version information value closing delimiter in the XML declaration.
147	The parser found an invalid attribute instead of the optional encoding declaration in the XML declaration.
148	'encoding' in the XML declaration was not followed by '='.
149	The encoding declaration value in the XML declaration is either missing or improperly delimited.
150	The encoding declaration value in the XML declaration specified a bad character, or the start and end delimiters did not match.
151	The parser found an invalid character following the encoding declaration value closing delimiter in the XML declaration.
152	The parser found an invalid attribute instead of the optional standalone declaration in the XML declaration.
153	standalone in the XML declaration was not followed by =.
154	The standalone declaration value in the XML declaration is either missing or improperly delimited.
155	The standalone declaration value was neither 'yes' nor 'no' only.
156	The standalone declaration value in the XML declaration specified a bad character, or the start and end delimiters did not match.
157	The parser found an invalid character following the standalone declaration value closing delimiter in the XML declaration.
158	The XML declaration was not terminated by the proper character sequence '?>', or contained an invalid attribute.
159	The parser found the start of a document type declaration after the end of the root element.
160	The parser found the start of an element after the end of the root element.
315	The <i>actual document encoding</i> was UTF-16 little-endian, which the parser does not support on this platform.
316	The actual document encoding was UCS4, which the parser does not support.
317	The parser cannot determine the document encoding. The document might be damaged.
318	The actual document encoding was UTF-8, which the parser does not support.
320	The document data item was national, but the actual document encoding was EBCDIC.
321	The document data item was national, but the actual document encoding was ASCII.
500 - 599	Internal error. Report the error to your service representative.

RELATED CONCEPTS

"XML-CODE" on page 535

XML GENERATE exceptions

One of several exception codes might be returned in the XML-CODE special register during XML generation. If one of these exceptions occurs, control is passed to the statement in the ON EXCEPTION phrase, or to the end of the XML GENERATE statement if you did not code an ON EXCEPTION phrase.

Table 98. XML GENERATE exceptions

Exception code (decimal)	Description
400	The receiver was too small to contain the generated XML document. The COUNT IN data item, if specified, contains the count of character positions that were actually generated.
401	A DBCS data-name contained a character that, when converted to Unicode, was not valid in an XML element or attribute name.
402	The first character of a DBCS data-name, when converted to Unicode, was not valid as the first character of an XML element or attribute name.
403	The value of an OCCURS DEPENDING ON variable exceeded 16,777,215.
410	The CCSID page specified by the CODEPAGE compiler option is not supported for conversion to Unicode.
411	The CCSID specified by the CODEPAGE compiler option is not a supported single-byte EBCDIC CCSID.
414	The CCSID specified for the XML document was invalid or was not supported.
415	The receiver was national, but the encoding specified for the document was not UTF-16.
416	The XML namespace identifier contained invalid XML characters.
417	Element character content or an attribute value contained characters that are illegal in XML content. XML generation has continued, with the element tag name or the attribute name prefixed with 'hex.' and the original data value represented in the document in hexadecimal. Any TYPE IS CONTENT specification is ignored, and the item is treated as an element.
418	Substitution characters were generated by encoding conversion.
419	The XML namespace prefix was invalid.
420	The receiver was alphanumeric and the input included national or DBCS data or names, but the encoding specified for the document was not 1208.
600-699	Internal error. Report the error to your service representative.

Appendix D. EXIT compiler option

You can use the EXIT compiler option to provide user-supplied modules in place of various compiler functions. For details about processing of each exit module, error handling for exit modules, or using the EXIT option with CICS, SQL and SQLIMS statements, see the following topics.

RELATED TASKS

“Using the user-exit work area”

“Calling from exit modules” on page 712

Using the EXIT compiler option with CICS, SQL and SQLIMS statements

RELATED REFERENCES

“EXIT” on page 324

“Processing of INEXIT” on page 712

“Processing of LIBEXIT” on page 713

“Processing of PRTEXTIT” on page 716

“Processing of ADEXIT” on page 717

“Processing of MSGEXIT” on page 719

“Error handling for exit modules” on page 727

Using the user-exit work area

When you use one of the user exits, the compiler provides a work area in which you can save the address of GETMAIN storage obtained by the exit module. Having such a work area lets the module be reentrant.

The user-exit work area consists of 6 fullwords that reside on a fullword boundary. These fullwords are initialized to binary zeros before the first exit routine is invoked. The address of the work area is passed to the exit module in a parameter list. After initialization, the compiler makes no further reference to the work area.

The words in the user-exit work area are used by the individual exit modules as shown in the following table.

Table 99. Layout of the user-exit work area

Word number	Used by module:
1	INEXIT
2	LIBEXIT
3	PRTEXTIT
4	ADEXIT
5	(Reserved)
6	MSGEXIT

RELATED REFERENCES

“Processing of INEXIT” on page 712

“Processing of LIBEXIT” on page 713

“Processing of PRTEXIT” on page 716
“Processing of ADEXIT” on page 717
“Processing of MSGEXIT” on page 719

Calling from exit modules

To call COBOL programs or library routines within your exit modules, use standard COBOL linkage. You need to be aware of the register conventions in order to trace the call chain correctly.

When a call is made to a program or to a routine in an exit module, the registers are set up as follows:

- R1** Points to the parameter list passed to the called program or library routine
- R13** Points to the register save area provided by the calling program or routine
- R14** Holds the return address of the calling program or routine
- R15** Holds the address of the called program or routine

Exit modules must have RMODE attribute 24 and AMODE attribute ANY.

RELATED CONCEPTS

“Storage and its addressability” on page 39

Processing of INEXIT

The INEXIT exit module is used to read source code from a user-supplied program object in place of SYSIN.

Table 100. INEXIT processing

Action by compiler	Action by exit module
Loads the exit module (<i>mod1</i>) during initialization	
Calls the exit module with an OPEN operation code (op code)	Prepares its source for processing. Passes the status of the OPEN request back to the compiler.
Calls the exit module with a GET op code when a source statement is needed	Returns either the address and length of the next statement or the end-of-data indication (if no more source statements exist)
Calls the exit module with a CLOSE op code when the end-of-data is presented	Releases any resources that are related to its output

INEXIT parameters

The compiler uses 10 parameters, passed by reference, to communicate with the exit module. The return code, data length, and data parameters are set by the exit module for return to the compiler; the other items are passed from the compiler to the exit module.

Table 101. INEXIT parameters

Parameter number	Parameter item	Description of item
1	User-exit type	Halfword that identifies which user exit is to perform the operation. 1=INEXIT
2	Operation code	Halfword that indicates the type of operation: <ul style="list-style-type: none"> • 0=OPEN • 1=CLOSE • 2=GET
3	Return code	Fullword, set by the exit module, that indicates the success of the requested operation: <ul style="list-style-type: none"> • 0=Operation was successful • 4=End-of-data • 12=Operation failed
4	User-exit work area	Six-fullword work area provided by the compiler for use by the user-exit module. First word: for use by INEXIT
5	Data length	Fullword, set by the exit module, that specifies the length of the record being returned by the GET operation (must be 80)
6	Data or <i>str1</i>	Fullword, set by the exit module, that contains the address of the record in a user-owned buffer, for the GET operation. <i>str1</i> applies only to OPEN. The first halfword (on a halfword boundary) contains the length of the string, followed by the string.
7	Not used	(Used only by LIBEXIT and MSGEXIT)
8	Not used	(Used only by LIBEXIT)
9	Not used	(Used only by LIBEXIT)
10	Not used	(Used only by LIBEXIT)

RELATED TASKS

“Using the user-exit work area” on page 711

“Calling from exit modules” on page 712

Using the EXIT compiler option with CICS, SQL and SQLIMS statements

Processing of LIBEXIT

The LIBEXIT exit module is used in place of the SYSLIB, or *library-name*, data set. Calls are made to the module by the compiler to obtain copybooks whenever COPY or BASIS statements are encountered.

Table 102. LIBEXIT processing

Action by compiler	Action by exit module
Loads the exit module (<i>mod2</i>) during initialization	

Table 102. LIBEXIT processing (continued)

Action by compiler	Action by exit module
Calls the exit module with an OPEN operation code (op code)	Prepares the specified <i>library-name</i> for processing. Passes the status of the OPEN request to the compiler.
Calls the exit module with a FIND op code if the <i>library-name</i> was successfully opened	Establishes positioning at the requested <i>text-name</i> (or <i>basis-name</i>) in the specified <i>library-name</i> ; this place becomes the active copybook. Passes an appropriate return code to the compiler when positioning is complete.
Calls the exit module with a GET op code	Passes the compiler either the length and address of the record to be copied from the active copybook or the end-of-data indicator
Calls the exit module with a CLOSE op code when the end-of-data is presented	Releases any resources that are related to its input

Processing of LIBEXIT with nested COPY statements

Any record from the active copybook can contain a COPY statement. (However, nested COPY statements cannot contain the REPLACING phrase, and a COPY statement with the REPLACING phrase cannot contain nested COPY statements.)

You cannot make recursive calls to *text-name*. That is, a copybook can be named only once in a set of nested COPY statements until the end-of-data for that copybook is reached.

The following table shows how the processing of LIBEXIT changes when there are one or more valid COPY statements that are not nested.

Table 103. LIBEXIT processing with nonnested COPY statements

Action by compiler	Action by exit module
Loads the exit module (<i>mod2</i>) during initialization	
Calls the exit module with an OPEN operation code (op code)	Prepares the specified <i>library-name</i> for processing. Passes the status of the OPEN request to the compiler.
Calls the exit module with a FIND op code if the <i>library-name</i> was successfully opened	Establishes positioning at the requested <i>text-name</i> (or <i>basis-name</i>) in the specified <i>library-name</i> ; this place becomes the active copybook. Passes an appropriate return code to the compiler when positioning is complete.
Calls the exit module with a FIND op code if the <i>library-name</i> was successfully opened	Reestablishes positioning at the previous active copybook. Passes an appropriate return code to the compiler when positioning is complete.
Calls the exit module with a GET op code. Verifies that the same record was passed.	Passes the compiler the same record as was passed previously from this copybook. After verification, passes either the length and address of the record to be copied from the active copybook or the end-of-data indicator.
Calls the exit module with a CLOSE op code when the end-of-data is presented	Releases any resources that are related to its input

The following table shows how the processing of LIBEXIT changes when the compiler encounters a valid nested COPY statement.

Table 104. LIBEXIT processing with nested COPY statements

Action by compiler	Action by exit module
If the requested <i>library-name</i> from the nested COPY statement was not previously opened, calls the exit module with an OPEN op code	Pushes its control information about the active copybook onto a stack. Completes the requested action (OPEN). The newly requested <i>text-name</i> (or <i>basis-name</i>) becomes the active copybook.
Calls the exit module with a FIND op code for the requested new <i>text-name</i>	Pushes its control information about the active copybook onto a stack. Completes the requested action (FIND). The newly requested <i>text-name</i> (or <i>basis-name</i>) becomes the active copybook.
Calls the exit module with a GET op code	Passes the compiler either the length and address of the record to be copied from the active copybook or the end-of-data indicator. At end-of-data, pops its control information from the stack.

LIBEXIT parameters

The compiler uses 10 parameters, passed by reference, to communicate with the exit module. The return code, data length, and data parameters are set by the exit module for return to the compiler; the other items are passed from the compiler to the exit module.

Table 105. LIBEXIT parameters

Parameter number	Parameter item	Description of item
1	User-exit type	Halfword that identifies which user exit is to perform the operation. 2=LIBEXIT
2	Operation code	Halfword that indicates the type of operation: <ul style="list-style-type: none"> • 0=OPEN • 1=CLOSE • 2=GET • 4=FIN
3	Return code	Fullword, set by the exit module, that indicates the success of the requested operation: <ul style="list-style-type: none"> • 0=Operation was successful • 4=End-of-data • 12=Operation failed
4	User-exit work area	Six-fullword work area provided by the compiler for use by the user-exit module. Second word: for use by LIBEXIT
5	Data length	Fullword, set by the exit module, that specifies the length of the record being returned by the GET operation (must be 80)

Table 105. LIBEXIT parameters (continued)

Parameter number	Parameter item	Description of item
6	Data or <i>str2</i>	Fullword, set by the exit module, that contains the address of the record in a user-owned buffer, for the GET operation. <i>str2</i> applies only to OPEN. The first halfword (on a halfword boundary) contains the length of the string, followed by the string.
7	System <i>library-name</i>	Eight-character area that contains the <i>library-name</i> from the COPY statement. Processing and conversion rules for a program-name are applied. Padded with blanks if required. Applies to OPEN, CLOSE, and FIND.
8	System <i>text-name</i>	Eight-character area that contains the <i>text-name</i> from the COPY statement (<i>basis-name</i> from BASIS statement). Processing and conversion rules for a program-name are applied. Padded with blanks if required. Applies only to FIND.
9	Library-name	Thirty-character area that contains the full <i>library-name</i> from the COPY statement. Padded with blanks if required, and used as is (not folded to uppercase). Applies to OPEN, CLOSE, and FIND.
10	Text-name	Thirty-character area that contains the full <i>text-name</i> from the COPY statement. Padded with blanks if required, and used as is (not folded to uppercase). Applies only to FIND.

RELATED TASKS

“Using the user-exit work area” on page 711

“Calling from exit modules” on page 712

Using the EXIT compiler option with CICS, SQL and SQLIMS statements

Processing of PRTEXT

The PRTEXT exit module is used in place of the SYSPRINT data set.

Table 106. PRTEXT processing

Action by compiler	Action by exit module
Loads the exit module (<i>mod3</i>) during initialization	
Calls the exit module with an OPEN operation code (op code)	Prepares its output destination for processing. Passes the status of the OPEN request to the compiler.
Calls the exit modules with a PUT op code when a line is to be printed, supplying the address and length of the record that is to be printed	Passes the status of the PUT request to the compiler by a return code. The first byte of the record to be printed contains an ANSI printer control character.
Calls the exit module with a CLOSE op code when the end-of-data is presented	Releases any resources that are related to its output destination

PRTEXT parameters

The compiler uses 10 parameters, passed by reference, to communicate with the exit module. The return code, data length, and data buffer parameters are set by the exit module for return to the compiler; the other items are passed from the compiler to the exit module.

Table 107. PRTEXT parameters

Parameter number	Parameter item	Description of item
1	User-exit type	Halfword that identifies which user exit is to perform the operation. 3=PRTEXT
2	Operation code	Halfword that indicates the type of operation: <ul style="list-style-type: none">• 0=OPEN• 1=CLOSE• 3=PUT
3	Return code	Fullword, set by the exit module, that indicates the success of the requested operation: <ul style="list-style-type: none">• 0=Operation was successful• 12=Operation failed
4	User-exit work area	Six-fullword work area provided by the compiler for use by the user-exit module. Third word: for use by PRTEXT
5	Data length	Fullword that specifies the length of the record being supplied by the PUT operation (the compiler sets this value to 133)
6	Data buffer or <i>str3</i>	Data buffer where the compiler has placed the record to be printed by the PUT operation. <i>str3</i> applies only to OPEN. The first halfword (on a halfword boundary) contains the length of the string, followed by the string.
7	Not used	(Used only by LIBEXIT and MSGEXIT)
8	Not used	(Used only by LIBEXIT)
9	Not used	(Used only by LIBEXIT)
10	Not used	(Used only by LIBEXIT)

RELATED TASKS

“Using the user-exit work area” on page 711

“Calling from exit modules” on page 712

Using the EXIT compiler option with CICS, SQL and SQLIMS statements

Processing of ADEXIT

The ADEXIT module is called for each SYSADATA record immediately after the record has been written out to the file.

To use an ADEXIT module, you must compile using the ADATA option to produce SYSADATA output, and code the SYSADATA DD statement.

Table 108. ADEXIT processing

Action by compiler	Action by exit module
Loads the exit module (<i>mod4</i>) during initialization	
Calls the exit module with an OPEN operation code (op code)	Prepares its output destination for processing. Passes the status of the OPEN request to the compiler.
Calls the exit module with a PUT op code when the compiler has written a SYSADATA record, supplying the address and length of the SYSADATA record	Passes the status of the PUT request to the compiler by a return code
Calls the exit module with a CLOSE op code when the end-of-data is presented	Releases any resources

ADEXIT parameters

The compiler uses 10 parameters, passed by reference, to communicate with the exit module. The return code, data length, and data buffer parameters are set by the exit module for return to the compiler; the other items are passed from the compiler to the exit module.

Table 109. ADEXIT parameters

Parameter number	Parameter item	Description of item
1	User-exit type	Halfword that identifies which user exit is to perform the operation. 4=ADEXIT
2	Operation code	Halfword that indicates the type of operation: <ul style="list-style-type: none"> • 0=OPEN • 1=CLOSE • 3=PUT
3	Return code	Fullword, set by the exit module, that indicates the success of the requested operation: <ul style="list-style-type: none"> • 0=Operation was successful • 12=Operation failed
4	User-exit work area	Six-fullword work area provided by the compiler for use by the user-exit module. Fourth word: for use by ADEXIT
5	Data length	Fullword that specifies the length of the record being supplied by the PUT operation
6	Data buffer or <i>str4</i>	Fullword that contains the address of the data buffer where the compiler has placed the record to be printed by the PUT operation. <i>str4</i> applies only to OPEN. The first halfword (on a halfword boundary) contains the length of the string, followed by the string.
7	Not used	(Used only by LIBEXIT and MSGEXIT)
8	Not used	(Used only by LIBEXIT)
9	Not used	(Used only by LIBEXIT)

Table 109. ADEXIT parameters (continued)

Parameter number	Parameter item	Description of item
10	Not used	(Used only by LIBEXIT)

RELATED TASKS

“Using the user-exit work area” on page 711
 “Calling from exit modules” on page 712
 Using the EXIT compiler option with CICS, SQL and SQLIMS statements

RELATED REFERENCES

“ADATA” on page 305

Processing of MSGEXIT

The MSGEXIT module is used to customize compiler diagnostic messages and FIPS messages. The module can customize a message either by changing its severity or suppressing it.

If the MSGEXIT module assigns a severity to a FIPS message, the message is converted into a diagnostic message. (The message is shown in the summary of diagnostic messages in the listing.)

A MSGEXIT summary at the end of the compiler listing shows how many messages were changed in severity and how many messages were suppressed.

Table 110. MSGEXIT processing

Action by compiler	Action by exit module
Loads the exit module (<i>mod5</i>) during initialization	
Calls the exit module with an OPEN operation code (op code)	Optionally processes <i>str5</i> and passes the status of the OPEN request to the compiler
Calls the exit module with a MSGSEV operation code (op code) when the compiler is about to issue a diagnostic message or FIPS message	One of the following actions: <ul style="list-style-type: none"> Indicates no customization of the message (by setting return code to 0) Specifies a new severity for (or suppression of) the message, and sets return code to 4 Indicates that the operation failed (by setting return code to 12)
Calls the exit module with a CLOSE op code	Optionally frees storage and passes the status of the CLOSE request to the compiler
Deletes the exit module (<i>mod5</i>) during compiler termination	

MSGEXIT parameters

The compiler uses 10 parameters, passed by reference, to communicate with the exit module. The return code and user-requested severity parameters are set by the exit module for return to the compiler; the other items are passed from the compiler to the exit module.

Table 111. MSGEXIT parameters

Parameter number	Parameter item	Description of item
1	User-exit type	Halfword that identifies which user exit is to perform the operation. 6=MSGEXIT
2	Operation code	Halfword that indicates the type of operation: <ul style="list-style-type: none"> • 0=OPEN • 1=CLOSE • 5=MSGSEV: customize message severity
3	Return code	Fullword, set by the exit module, that indicates the success of the requested operation. For op code MSGSEV: <ul style="list-style-type: none"> • 0=Message not customized • 4=Message found and customized • 12=Operation failed
4	User-exit work area	Six-fullword work area provided by the compiler for use by the user-exit module. Sixth word: for use by MSGEXIT
5	Not used	(Used by the other exits)
6	Message exit data	Three-halfword area (on a halfword boundary). <ul style="list-style-type: none"> • First halfword: the message number of the message to be customized • Second halfword: for a diagnostic message, the default severity; for a FIPS message, the FIPS category as a numeric code • Third halfword: the user-requested severity for the message (-1 to indicate suppression)
7	<i>str5</i>	First halfword (on a halfword boundary): the length of the string, followed by the string
8	Not used	(Used only by LIBEXIT)
9	Not used	(Used only by LIBEXIT)
10	Not used	(Used only by LIBEXIT)

“Example: MSGEXIT user exit” on page 723

RELATED TASKS

“Using the user-exit work area” on page 711

“Calling from exit modules” on page 712

“Customizing compiler-message severities”

Using the EXIT compiler option with CICS, SQL and SQLIMS statements

Customizing compiler-message severities

To change the severities of compiler messages or suppress compiler messages (including FIPS messages), do the steps described below.

1. Code and compile a COBOL program named ERRMSG. The program needs only a PROGRAM-ID paragraph, as described in the related task.

2. Review the ERRMSG listing, which contains a complete list of compiler messages with their message numbers, severities, and message text.
3. Decide which messages you want to customize.
To understand the customizations that are possible, see the related reference about customizable compiler-message severities.
4. Code a MSGEXIT module to implement the customizations:
 - a. Verify that the operation-code parameter indicates message-severity customization.
 - b. Check the two input values in the message-exit-data parameter: the message number; and the default severity for a diagnostic message or the FIPS category for a FIPS message.
The FIPS category is expressed as numeric code. For details, see the related reference about customizable compiler-message severities.
 - c. For a message that you want to customize, set the user-requested severity in the message-exit-data parameter to indicate either:
 - A new message severity, by coding severity 0, 4, 8, or 12
 - Message suppression, by coding severity -1
 - d. Set the return code to one of the following values:
 - 0, to indicate that the message was not customized
 - 4, to indicate that the message was found and customized
 - 12, to indicate that the operation failed and that compilation should be terminated
5. Compile and link your MSGEXIT module.
6. Add the data set that contains your MSGEXIT module to the compiler concatenation by using a STEPLIB or JOBLIB DD statement.
7. Recompile program ERRMSG, but use compiler option EXIT(MSGEXIT(*msgmod*)), where *msgmod* is the name of your MSGEXIT module.
8. Review the listing and check for:
 - Updated message severities
 - Suppressed messages (indicated by XX in place of the severity)
 - Unsupported severity changes or unsupported message suppression (indicated by a severity-U diagnostic message, and compiler termination with return code 16)

RELATED TASKS

“Generating a list of compiler messages” on page 280

RELATED REFERENCES

“Severity codes for compiler diagnostic messages” on page 282

“Customizable compiler-message severities”

“Effect of message customization on compilation return code” on page 722

“Error handling for exit modules” on page 727

Customizable compiler-message severities

To customize compiler-message severities, you need to understand the possible severities of compiler diagnostic messages, the levels or categories of FIPS messages, and the permitted customizations of message severities.

The possible severity codes for compiler diagnostic messages are described in the related reference about severity codes.

The eight categories of FIPS (FLAGSTD) messages are shown in the following table. The category of any given FIPS message is passed as a numeric code to the MSGEXIT module. Those numeric codes are shown in the second column.

Table 112. FIPS (FLAGSTD) message categories

FIPS level or category	Numeric code	Description
D	81	Debug module level 1
E	82	Extension (IBM)
H	83	High level
I	84	Intermediate level
N	85	Segmentation module level 1
O	86	Obsolete elements
Q	87	High-level and obsolete elements
S	88	Segmentation module level 2

FIPS messages have an implied severity of zero (severity I).

Permitted message-severity customizations:

You can change the severity of a compiler message in the following ways:

- Severity-I and severity-W compiler diagnostic messages, and FIPS messages, can be changed to have any severity from I through S.

Assigning a severity to a FIPS message converts the FIPS message to a diagnostic message of the assigned severity.

As examples, you can:

- Lower an optimizer warning to severity I.
- Disallow REDEFINING a smaller item with a larger item by raising the severity of message 1154.
- Disallow complex OCCURS DEPENDING ON by changing FIPS message 8235 from a category-E FIPS message to a severity-S compiler diagnostic message.
- Severity-E messages can be raised to severity S, but not lowered to severity I or W, because an error condition has occurred in the program.
- Severity-S and severity-U messages cannot be changed to have a different severity.

You can request suppression of compiler messages as follows:

- I, W, and FIPS messages can be suppressed.
- E and S messages cannot be suppressed.

RELATED REFERENCES

“Severity codes for compiler diagnostic messages” on page 282

“FLAGSTD” on page 329

“Effect of message customization on compilation return code”

Effect of message customization on compilation return code

If you use a MSGEXIT module, the final return code from the compilation of a program could be affected as described below.

If you change the severity of a message, the return code from the compilation might also be changed. For example, if a compilation produces one diagnostic

message, and it is a severity-E message, the compilation return code would normally be 8. But if the MSGEXIT module changes the severity of that message to severity S, then the return code from compilation would be 12.

If you suppress a message, the return code from the compilation is no longer affected by the severity of that message. For example, if a compilation produces one diagnostic message, and it is a severity-W message, the compilation return code would normally be 4. But if the MSGEXIT module suppresses that message, then the return code from compilation would be 0.

RELATED TASKS

“Customizing compiler-message severities” on page 720

RELATED REFERENCES

“Severity codes for compiler diagnostic messages” on page 282

Example: MSGEXIT user exit

The following example shows a MSGEXIT user-exit module that changes message severities and suppresses messages.

For helpful tips about using a message-exit module, see the comments within the code.

```
*****
* IGYMSGXT - Sample COBOL program for MSGEXIT *
*****
* Function: This is a SAMPLE user exit for the MSGEXIT *
*           suboption of the EXIT compiler option. This exit *
*           can be used to customize the severity of or *
*           suppress compiler diagnostic messages and FIPS *
*           messages. This example program includes several *
*           sample customizations to show how customizations *
*           are done. If you do not want the sample *
*           customizations then either delete the unwanted *
*           lines of code or comment them out with a comment *
*           indicator in column 7 (*). *
* *
*-----*
* *
* USAGE NOTE: To use this user exit program, make the *
* link-edited program object available to your *
* compiles that will use the MSGEXIT suboption of *
* the EXIT compiler option. Also, the name should *
* be changed, since IBM recommends that you avoid *
* having programs with names that start with IGY. *
* Sample steps to take: *
* 1) Make your customizations *
* 2) Change program name (E.G. MSGEXT) *
* 3) Compile and link into a data set *
* 4) Include that data set in your compile *
* JCL concatenation for the compile step. *
* If you link into USER.COBOLLIB: *
* *
* //COBOL.STEPLIB DD DSNAME=SYS1.SIGYCOMP,DISP=SHR *
* // DD DSNAME=USER.COBOLLIB,DISP=SHR *
* *
*****
Id Division.
Program-Id. IGYMSGXT.
Data Division.
```

Working-Storage Section.

```

*****
*
*   Local variables.
*
*****

    77 EXIT-TYPEN          PIC 9(4).
    77 EXIT-DEFAULT-SEV-FIPS PIC X.

*****
*
*   Definition of the User-Exit Parameter List, which is
*   passed from the COBOL compiler to the user-exit module.
*
*****

Linkage Section.
01 EXIT-TYPE          PIC 9(4)  COMP.
01 EXIT-OPERATION    PIC 9(4)  COMP.
01 EXIT-RETURNCODE   PIC 9(9)  COMP.
01 EXIT-WORK-AREA.
    02 EXIT-WORK-AREA-PTR OCCURS 6 POINTER.
01 EXIT-DUMMY        POINTER.
01 EXIT-MESSAGE-PARMS.
    02 EXIT-MESSAGE-NUM PIC 9(4)  COMP.
    02 EXIT-DEFAULT-SEV PIC 9(4)  COMP.
    02 EXIT-USER-SEV   PIC S9(4)  COMP.
01 EXIT-STRING.
    02 EXIT-STR-LEN PIC 9(4)  COMP.
    02 EXIT-STR-TXT PIC X(64).

*****
*****
*
*   Begin PROCEDURE DIVISION
*
*   Check parameters and perform the operation requested.
*
*****
*****

Procedure Division Using EXIT-TYPE          EXIT-OPERATION
                        EXIT-RETURNCODE    EXIT-WORK-AREA
                        EXIT-DUMMY         EXIT-MESSAGE-PARMS
                        EXIT-STRING        EXIT-DUMMY
                        EXIT-DUMMY         EXIT-DUMMY.

    Compute EXIT-RETURNCODE = 0

    Evaluate TRUE

*****
*   Handle a bad invocation of this exit by the compiler.
*   This could happen if this routine was used for one of the
*   other EXITS, such as INEXIT, PRTEXTIT or LIBEXIT.
*****
    When EXIT-TYPE Not = 6
        Move EXIT-TYPE to EXIT-TYPEN
        Display '**** Invalid exit routine identifier'
        Display '**** EXIT TYPE = ' EXIT-TYPE
        Compute EXIT-RETURNCODE = 16

*****
*   Handle the OPEN call to this exit by the compiler
*   Display the exit string (str5 in syntax diagram) from
*   the EXIT(MSGEXIT('str5',mod5)) option specification.
*****

```

```

        When EXIT-OPERATION = 0
*       Display 'Opening MSGEXIT'
*       If EXIT-STR-LEN Not Zero Then
*         Display ' str5 len = ' EXIT-STR-LEN
*         Display ' str5 = ' EXIT-STR-TXT(1:EXIT-STR-LEN)
*       End-If
        Continue

*****
* Handle the CLOSE call to this exit by the compiler *
*****
        When EXIT-OPERATION = 1
*       Display 'Closing MSGEXIT'
        GOBACK

*****
* Handle the customize message severity call to this exit *
*       Display information about every customized severity. *
*****
        When EXIT-OPERATION = 5
*       Display 'MSGEXIT called with MSGSEV'
        If EXIT-MESSAGE-NUM < 8000 Then
            Perform Error-Messages-Severity
        Else
            Perform FIPS-Messages-Severity
        End-If

*       If EXIT-RETURNCODE = 4 Then
*         Display '>>>> Customizing message ' EXIT=MESSAGE-NUM
*           ' with new severity ' EXIT-USER-SEV ' <<<<'
*         If EXIT-MESSAGE-NUM > 8000 Then
*           Display 'FIPS sev =' EXIT-DEFAULT-SEV-FIPS '<<<<'
*         End-If
*       End-If

*****
* Handle a bad invocation of this exit by the compiler *
* The compiler should not invoke this exit with EXIT-TYPE = 6 *
* and an opcode other than 0, 1, or 5. This should not happen *
* and IBM service should be contacted if it does. *
*****
        When Other
            Display '**** Invalid MSGEXIT routine operation '
            Display '**** EXIT OPCODE = ' EXIT-OPERATION
            Compute EXIT-RETURNCODE = 16

        End-Evaluate

        Goback.

*****
*       ERROR MESSAGE PROCESSOR *
*****
        Error-Messages-Severity.

*       Assume message severity will be customized...
        Compute EXIT-RETURNCODE = 4

        Evaluate EXIT-MESSAGE-NUM

*****
*       Change severity of message 1154(W) to 12 ('S')
*       This is the case of redefining a large item
*       with a smaller item, IBM Req # MR0904063236
*****
        When(1154)
            Compute EXIT-USER-SEV = 12

```

```

*****
*   Change severity of messages 3188(W) and 3189(W)
*   to 12 ('S'). This is to force a fix for all
*   SEARCH ALL cases that might behave differently
*   between COBOL compilers previous to Enterprise
*   COBOL release V3R4 and later compilers such as
*   Enterprise COBOL Version 4 Release 2.
*   Another way to handle this migration is to analyze all of
*   the warnings you get and then change them to I-level when
*   the analysis is complete.
*****
      When(3188) When(3189)
        Compute EXIT-USER-SEV = 12

*****
*   Message severity Not customized
*****
      When Other
        Compute EXIT-RETURNCODE = 0

      End-Evaluate
      .
*****
*   FIPS MESSAGE PROCESSOR
*****
      Fips-Messages-Severity.

*   Assume message severity will be customized...
      Compute EXIT-RETURNCODE = 4

*   Convert numeric FIPS(FLAGSTD) 'category' to character
*   See the Programming Guide for description of FIPS category

      EVALUATE EXIT-DEFAULT-SEV
        When 81
          MOVE 'D' To EXIT-DEFAULT-SEV-FIPS
        When 82
          MOVE 'E' To EXIT-DEFAULT-SEV-FIPS
        When 83
          MOVE 'H' To EXIT-DEFAULT-SEV-FIPS
        When 84
          MOVE 'I' To EXIT-DEFAULT-SEV-FIPS
        When 85
          MOVE 'N' To EXIT-DEFAULT-SEV-FIPS
        When 86
          MOVE 'O' To EXIT-DEFAULT-SEV-FIPS
        When 87
          MOVE 'Q' To EXIT-DEFAULT-SEV-FIPS
        When 88
          MOVE 'S' To EXIT-DEFAULT-SEV-FIPS
        When Other
          Continue
      End-Evaluate

*****
*   Example of using FIPS category to force coding
*   restrictions. This is not a recommendation!
*   Change severity of all OBSOLETE item FIPS
*   messages to 'S'
*****
*   If EXIT-DEFAULT-SEV-FIPS = 'O' Then
*   Display '>>>> Default customizing FIPS category '
*   EXIT-DEFAULT-SEV-FIPS ' msg ' EXIT-MESSAGE-NUM '<<<<'
*   Compute EXIT-USER-SEV = 12
*   End-If

```

```

        Evaluate EXIT-MESSAGE-NUM
*****
*      Change severity of message 8062(0) to 8 ('E')
*      8062 = GO TO without proc name
*****
        When(8062)
            Compute EXIT-USER-SEV = 8

*****
*      Change severity of message 8193(E) to 0('I')
*      8193 = GOBACK
*****
        When(8193)
            Compute EXIT-USER-SEV = 0

*****
*      Change severity of message 8235(E) to 8 (Error)
*      to disallow Complex Occurs Depending On
*      8235 = Complex Occurs Depending On
*****
        When(8235)
            Compute EXIT-USER-SEV = 08

*****
*      Change severity of message 8270(0) to -1 (Suppress)
*      8270 = SERVICE LABEL
*****
        When(8270)
            Compute EXIT-USER-SEV = -1

*****
*      Message severity Not customized
*****
        When Other
            For the default set '0' to 'S' case...
            If EXIT-USER-SEV = 12 Then
                Compute EXIT-RETURNCODE = 4
            Else
                Compute EXIT-RETURNCODE = 0
            End-If

        End-Evaluate
    .
END PROGRAM IGYMSGXT.

```

Error handling for exit modules

The conditions described below can occur during processing of the user exits.

Exit load failure:

Message IGYSI5207-U is written to the operator if a LOAD request for any of the user exits fails:

An error occurred while attempting to load user exit *exit-name*.

Exit open failure:

Message IGYSI5208-U is written to the operator if an OPEN request for any of the user exits fails:

An error occurred while attempting to open user exit *exit-name*.

PRTEXIT PUT failure:

- Message IGYSI5203-U is written to the listing:

A PUT request to the PRTEXT user exit failed with return code *nn*.

- Message IGYSI5217-U is written to the operator:
An error occurred in PRTEXT user exit *exit-name*. Compiler terminated.

SYSIN GET failures:

The following messages might be written to the listing:

- IGYSI5204-U:
The record address was not set by the *exit-name* user exit.
- IGYSI5205-U:
A GET request from the INEXIT user exit failed with return code *nn*.
- IGYSI5206-U:
The record length was not set by the *exit-name* user exit.

ADEXIT PUT failure:

- Message IGYSI5225-U is written to the operator:
An error occurred in ADEXIT user exit *exit-name*. Compiler terminated.
- Message IGYSI5226-U is written to the listing:
A PUT request to the ADEXIT user exit failed with return code *nn*.

MSGEXIT failures:

Customization failure: Message IGYPP5293-U is written to the listing if an unsupported severity change or unsupported message suppression is attempted:

MSGEXIT user exit *exit-name* specified a message severity customization that is not supported. The message number, default severity, and user-specified severity were: *mm*, *ds*, *us*. Change MSGEXIT user exit *exit-name* to correct this error.

General failure: Message IGYPP5064-U is written to the listing if the MSGEXIT module sets the return code to a nonzero value other than 4:

A call to the MSGEXIT user exit routine *exit-name* failed with return code *nn*.

In the MSGEXIT messages, the two characters *PP* indicate the phase of the compiler that issued the message that resulted in a call to the MSGEXIT module.

RELATED TASKS

“Customizing compiler-message severities” on page 720

Using the EXIT compiler option with CICS, SQL and SQLIMS statements

When you compile using suboptions of the EXIT compiler option, and your program contains EXEC CICS, EXEC SQL, or EXEC SQLIMS statements, the actions that you can take in the exit modules depend on whether you use the separate CICS translator and DB2 precompiler, or the integrated CICS translator and DB2 coprocessor.

If the program contains EXEC SQLIMS statements, the actions that you can take in the exit modules are the actions that are listed for the integrated translator.

The following table shows which actions you can take in the exit modules depending on whether you use the integrated or separate translators.

Table 113. Actions possible in exit modules for CICS, SQL and SQLIMS statements

Compile with suboption	Translated with integrated or separate CICS and DB2 translators?	Possible actions	Comments
INEXIT	Integrated	Can process EXEC CICS, EXEC SQL, and EXEC SQLIMS statements in the INEXIT module	The INEXIT module does not get control of the COBOL statements that are generated for the EXEC statements.
	Separate	Can process the COBOL statements that are generated for the EXEC statements in the INEXIT module	You can change the generated statements in the INEXIT module, but doing so is not supported by IBM.
LIBEXIT	Integrated	Can process in the LIBEXIT module the statements that are brought in by the EXEC SQL INCLUDE and EXEC SQLIMS INCLUDE statements. Can process EXEC CICS source statements in the LIBEXIT module.	EXEC SQL INCLUDE and EXEC SQLIMS INCLUDE statements are processed like COBOL COPY statements.
	Separate	Can process the COBOL statements that are generated for the EXEC CICS statements in the LIBEXIT module	You can process the input statements that are brought in by the EXEC SQL INCLUDE and SQLIMS INCLUDE statements only by using the INEXIT suboption.
PRTEXIT	Integrated	Can process the EXEC CICS , EXEC SQL, and EXEC SQLIMS source statements from the SOURCE listing in the PRTEXIT module	The PRTEXIT module does not have access to the COBOL statements that are generated.
	Separate	Can process the COBOL SOURCE listing statements that are generated for the EXEC statements in the PRTEXIT module	
ADEXIT	Integrated	Can process the EXEC CICS, EXEC SQL, and EXEC SQLIMS source statements in the ADEXIT module	The ADEXIT module does not have access to the COBOL statements that are generated.
	Separate	Can process the COBOL SYSADATA statements that are generated for the EXEC statements in the ADEXIT module	
MSGEXIT	Integrated	Can process CICS and DB2 messages in the MSGEXIT module	
	Separate	Cannot process CICS and DB2 messages in the MSGEXIT module	Messages from CICS are shown in the separate CICS translator listing; messages from DB2 are shown in the DB2 precompiler listing.

RELATED CONCEPTS

“Integrated CICS translator” on page 435

“DB2 coprocessor” on page 441

RELATED TASKS

“Compiling with the CICS option” on page 433

“Compiling with the SQL option” on page 445

RELATED REFERENCES

“Processing of INEXIT” on page 712

"Processing of LIBEXIT" on page 713
"Processing of PRTEXT" on page 716
"Processing of ADEXIT" on page 717
"Processing of MSGEXIT" on page 719

Appendix E. JNI.cpy copybook

This listing shows the JNI.cpy copybook, which you can use to access the Java Native Interface (JNI) services from your COBOL programs.

JNI.cpy contains sample COBOL data definitions that correspond to the Java JNI types, and contains JNINativeInterface, the JNI environment structure that contains function pointers for accessing the JNI callable services.

JNI.cpy is in the z/OS UNIX file system in the include subdirectory of the COBOL install directory (typically /usr/lpp/cobol/include). JNI.cpy is analogous to the header file jni.h that C programmers use to access the JNI.

```
*****
* COBOL declarations for Java native method interoperation      *
*                                                                *
* To use the Java Native Interface callable services from a    *
* COBOL program:                                              *
* 1) Use a COPY statement to include this file into the        *
*    the Linkage Section of the program, e.g.                  *
*        Linkage Section.                                     *
*        Copy JNI                                             *
* 2) Code the following statements at the beginning of the     *
*    Procedure Division:                                       *
*        Set address of JNIEnv to JNIEnvPtr                    *
*        Set address of JNINativeInterface to JNIEnv          *
*****
*
* Sample JNI type definitions in COBOL
*
*01 jboolean1 pic X.
* 88 jboolean1-true value X'01' through X'FF'.
* 88 jboolean1-false value X'00'.
*
*01 jbyte1 pic X.
*
*01 jchar1 pic N usage national.
*
*01 jshort1 pic s9(4) comp-5.
*01 jint1 pic s9(9) comp-5.
*01 jlong1 pic s9(18) comp-5.
*
*01 jfloat1 comp-1.
*01 jdouble1 comp-2.
*
*01 jobject1 object reference.
*01 jclass1 object reference.
*01 jstring1 object reference jstring.
*01 jarray1 object reference jarray.
*
*01 jbooleanArray1 object reference jbooleanArray.
*01 jbyteArray1 object reference jbyteArray.
*01 jcharArray1 object reference jcharArray.
*01 jshortArray1 object reference jshortArray.
*01 jintArray1 object reference jintArray.
*01 jlongArray1 object reference jlongArray.
*01 floatArray1 object reference floatArray.
*01 jdoubleArray1 object reference jdoubleArray.
*01 jobjectArray1 object reference jobjectArray.
```

```
* Possible return values for JNI functions.
```

```

01 JNI-RC pic S9(9) comp-5.
* success
  88 JNI-OK      value 0.
* unknown error
  88 JNI-ERR     value -1.
* thread detached from the VM
  88 JNI-EDETACHED value -2.
* JNI version error
  88 JNI-EVERSION value -3.
* not enough memory
  88 JNI-ENOMEM  value -4.
* VM already created
  88 JNI-EEXIST  value -5.
* invalid arguments
  88 JNI-EINVAL  value -6.

* Used in ReleaseScalarArrayElements
01 releaseMode pic s9(9) comp-5.
  88 JNI-COMMIT value 1.
  88 JNI-ABORT  value 2.

01 JNIenv pointer.

* JNI Native Method Interface - environment structure.
01 JNINativeInterface.
  02 pointer.
  02 pointer.
  02 pointer.
  02 pointer.
  02 GetVersion                function-pointer.
  02 DefineClass               function-pointer.
  02 FindClass                 function-pointer.
  02 FromReflectedMethod      function-pointer.
  02 FromReflectedField      function-pointer.
  02 ToReflectedMethod        function-pointer.
  02 GetSuperclass             function-pointer.
  02 IsAssignableFrom         function-pointer.
  02 ToReflectedField         function-pointer.
  02 Throw                     function-pointer.
  02 ThrowNew                  function-pointer.
  02 ExceptionOccurred         function-pointer.
  02 ExceptionDescribe         function-pointer.
  02 ExceptionClear            function-pointer.
  02 FatalError                function-pointer.
  02 PushLocalFrame           function-pointer.
  02 PopLocalFrame             function-pointer.
  02 NewGlobalRef              function-pointer.
  02 DeleteGlobalRef           function-pointer.
  02 DeleteLocalRef            function-pointer.
  02 IsSameObject              function-pointer.
  02 NewLocalRef               function-pointer.
  02 EnsureLocalCapacity       function-pointer.
  02 AllocObject               function-pointer.
  02 NewObject                  function-pointer.
  02 NewObjectV                 function-pointer.
  02 NewObjectA                 function-pointer.
  02 GetObjectClass             function-pointer.
  02 IsInstanceOf               function-pointer.
  02 GetMethodID                function-pointer.
  02 CallObjectMethod           function-pointer.
  02 CallObjectMethodV          function-pointer.
  02 CallObjectMethodA          function-pointer.
  02 CallBooleanMethod         function-pointer.
  02 CallBooleanMethodV        function-pointer.
  02 CallBooleanMethodA        function-pointer.
  02 CallByteMethod            function-pointer.
  02 CallByteMethodV           function-pointer.

```

02 CallByteMethodA	function-pointer.
02 CallCharMethod	function-pointer.
02 CallCharMethodV	function-pointer.
02 CallCharMethodA	function-pointer.
02 CallShortMethod	function-pointer.
02 CallShortMethodV	function-pointer.
02 CallShortMethodA	function-pointer.
02 CallIntMethod	function-pointer.
02 CallIntMethodV	function-pointer.
02 CallIntMethodA	function-pointer.
02 CallLongMethod	function-pointer.
02 CallLongMethodV	function-pointer.
02 CallLongMethodA	function-pointer.
02 CallFloatMethod	function-pointer.
02 CallFloatMethodV	function-pointer.
02 CallFloatMethodA	function-pointer.
02 CallDoubleMethod	function-pointer.
02 CallDoubleMethodV	function-pointer.
02 CallDoubleMethodA	function-pointer.
02 CallVoidMethod	function-pointer.
02 CallVoidMethodV	function-pointer.
02 CallVoidMethodA	function-pointer.
02 CallNonvirtualObjectMethod	function-pointer.
02 CallNonvirtualObjectMethodV	function-pointer.
02 CallNonvirtualObjectMethodA	function-pointer.
02 CallNonvirtualBooleanMethod	function-pointer.
02 CallNonvirtualBooleanMethodV	function-pointer.
02 CallNonvirtualBooleanMethodA	function-pointer.
02 CallNonvirtualByteMethod	function-pointer.
02 CallNonvirtualByteMethodV	function-pointer.
02 CallNonvirtualByteMethodA	function-pointer.
02 CallNonvirtualCharMethod	function-pointer.
02 CallNonvirtualCharMethodV	function-pointer.
02 CallNonvirtualCharMethodA	function-pointer.
02 CallNonvirtualShortMethod	function-pointer.
02 CallNonvirtualShortMethodV	function-pointer.
02 CallNonvirtualShortMethodA	function-pointer.
02 CallNonvirtualIntMethod	function-pointer.
02 CallNonvirtualIntMethodV	function-pointer.
02 CallNonvirtualIntMethodA	function-pointer.
02 CallNonvirtualLongMethod	function-pointer.
02 CallNonvirtualLongMethodV	function-pointer.
02 CallNonvirtualLongMethodA	function-pointer.
02 CallNonvirtualFloatMethod	function-pointer.
02 CallNonvirtualFloatMethodV	function-pointer.
02 CallNonvirtualFloatMethodA	function-pointer.
02 CallNonvirtualDoubleMethod	function-pointer.
02 CallNonvirtualDoubleMethodV	function-pointer.
02 CallNonvirtualDoubleMethodA	function-pointer.
02 CallNonvirtualVoidMethod	function-pointer.
02 CallNonvirtualVoidMethodV	function-pointer.
02 CallNonvirtualVoidMethodA	function-pointer.
02 GetFieldID	function-pointer.
02 GetObjectField	function-pointer.
02 GetBooleanField	function-pointer.
02 GetByteField	function-pointer.
02 GetCharField	function-pointer.
02 GetShortField	function-pointer.
02 GetIntField	function-pointer.
02 GetLongField	function-pointer.
02 GetFloatField	function-pointer.
02 GetDoubleField	function-pointer.
02 SetObjectField	function-pointer.
02 SetBooleanField	function-pointer.
02 SetByteField	function-pointer.
02 SetCharField	function-pointer.
02 SetShortField	function-pointer.

02 SetIntField	function-pointer.
02 SetLongField	function-pointer.
02 SetFloatField	function-pointer.
02 SetDoubleField	function-pointer.
02 GetStaticMethodID	function-pointer.
02 CallStaticObjectMethod	function-pointer.
02 CallStaticObjectMethodV	function-pointer.
02 CallStaticObjectMethodA	function-pointer.
02 CallStaticBooleanMethod	function-pointer.
02 CallStaticBooleanMethodV	function-pointer.
02 CallStaticBooleanMethodA	function-pointer.
02 CallStaticByteMethod	function-pointer.
02 CallStaticByteMethodV	function-pointer.
02 CallStaticByteMethodA	function-pointer.
02 CallStaticCharMethod	function-pointer.
02 CallStaticCharMethodV	function-pointer.
02 CallStaticCharMethodA	function-pointer.
02 CallStaticShortMethod	function-pointer.
02 CallStaticShortMethodV	function-pointer.
02 CallStaticShortMethodA	function-pointer.
02 CallStaticIntMethod	function-pointer.
02 CallStaticIntMethodV	function-pointer.
02 CallStaticIntMethodA	function-pointer.
02 CallStaticLongMethod	function-pointer.
02 CallStaticLongMethodV	function-pointer.
02 CallStaticLongMethodA	function-pointer.
02 CallStaticFloatMethod	function-pointer.
02 CallStaticFloatMethodV	function-pointer.
02 CallStaticFloatMethodA	function-pointer.
02 CallStaticDoubleMethod	function-pointer.
02 CallStaticDoubleMethodV	function-pointer.
02 CallStaticDoubleMethodA	function-pointer.
02 CallStaticVoidMethod	function-pointer.
02 CallStaticVoidMethodV	function-pointer.
02 CallStaticVoidMethodA	function-pointer.
02 GetStaticFieldID	function-pointer.
02 GetStaticObjectField	function-pointer.
02 GetStaticBooleanField	function-pointer.
02 GetStaticByteField	function-pointer.
02 GetStaticCharField	function-pointer.
02 GetStaticShortField	function-pointer.
02 GetStaticIntField	function-pointer.
02 GetStaticLongField	function-pointer.
02 GetStaticFloatField	function-pointer.
02 GetStaticDoubleField	function-pointer.
02 SetStaticObjectField	function-pointer.
02 SetStaticBooleanField	function-pointer.
02 SetStaticByteField	function-pointer.
02 SetStaticCharField	function-pointer.
02 SetStaticShortField	function-pointer.
02 SetStaticIntField	function-pointer.
02 SetStaticLongField	function-pointer.
02 SetStaticFloatField	function-pointer.
02 SetStaticDoubleField	function-pointer.
02 NewString	function-pointer.
02 GetStringLength	function-pointer.
02 GetStringChars	function-pointer.
02 ReleaseStringChars	function-pointer.
02 NewStringUTF	function-pointer.
02 GetStringUTFLength	function-pointer.
02 GetStringUTFChars	function-pointer.
02 ReleaseStringUTFChars	function-pointer.
02 GetArrayLength	function-pointer.
02 NewObjectArray	function-pointer.
02 GetObjectArrayElement	function-pointer.
02 SetObjectArrayElement	function-pointer.
02 NewBooleanArray	function-pointer.

02 NewByteArray	function-pointer.
02 NewCharArray	function-pointer.
02 NewShortArray	function-pointer.
02 NewIntArray	function-pointer.
02 NewLongArray	function-pointer.
02 NewFloatArray	function-pointer.
02 NewDoubleArray	function-pointer.
02 GetBooleanArrayElements	function-pointer.
02 GetByteArrayElements	function-pointer.
02 GetCharArrayElements	function-pointer.
02 GetShortArrayElements	function-pointer.
02 GetIntArrayElements	function-pointer.
02 GetLongArrayElements	function-pointer.
02 GetFloatArrayElements	function-pointer.
02 GetDoubleArrayElements	function-pointer.
02 ReleaseBooleanArrayElements	function-pointer.
02 ReleaseByteArrayElements	function-pointer.
02 ReleaseCharArrayElements	function-pointer.
02 ReleaseShortArrayElements	function-pointer.
02 ReleaseIntArrayElements	function-pointer.
02 ReleaseLongArrayElements	function-pointer.
02 ReleaseFloatArrayElements	function-pointer.
02 ReleaseDoubleArrayElements	function-pointer.
02 GetBooleanArrayRegion	function-pointer.
02 GetByteArrayRegion	function-pointer.
02 GetCharArrayRegion	function-pointer.
02 GetShortArrayRegion	function-pointer.
02 GetIntArrayRegion	function-pointer.
02 GetLongArrayRegion	function-pointer.
02 GetFloatArrayRegion	function-pointer.
02 GetDoubleArrayRegion	function-pointer.
02 SetBooleanArrayRegion	function-pointer.
02 SetByteArrayRegion	function-pointer.
02 SetCharArrayRegion	function-pointer.
02 SetShortArrayRegion	function-pointer.
02 SetIntArrayRegion	function-pointer.
02 SetLongArrayRegion	function-pointer.
02 SetFloatArrayRegion	function-pointer.
02 SetDoubleArrayRegion	function-pointer.
02 RegisterNatives	function-pointer.
02 UnregisterNatives	function-pointer.
02 MonitorEnter	function-pointer.
02 MonitorExit	function-pointer.
02 GetJavaVM	function-pointer.
02 GetStringRegion	function-pointer.
02 GetStringUTFRegion	function-pointer.
02 GetPrimitiveArrayCritical	function-pointer.
02 ReleasePrimitiveArrayCritical	function-pointer.
02 GetStringCritical	function-pointer.
02 ReleaseStringCritical	function-pointer.
02 NewWeakGlobalRef	function-pointer.
02 DeleteWeakGlobalRef	function-pointer.
02 ExceptionCheck	function-pointer.

RELATED TASKS

“Compiling OO applications under z/OS UNIX” on page 291

“Accessing JNI services” on page 633

Appendix F. COBOL SYSADATA file contents

When you use the ADATA compiler option, the compiler produces a file, the SYSADATA file, that contains additional program data. You can use this file instead of the compiler listing to extract information about the program. For example, you can extract information about the program for symbolic debugging tools or cross-reference tools.

“Example: SYSADATA” on page 739

RELATED REFERENCES

“ADATA” on page 305

“Compiler options that affect the SYSADATA file”

“SYSADATA record types” on page 738

“SYSADATA record descriptions” on page 740

Compiler options that affect the SYSADATA file

Several compiler options could affect the contents of the SYSADATA file.

COMPILE

NOCOMPILE(W|E|S) might stop compilation prematurely, resulting in the loss of specific messages.

EXIT INEXIT prohibits identification of the compilation source file.

LANGUAGE

LANGUAGE controls the message text (Uppercase English, Mixed-Case English, or Japanese). Selection of Japanese could result in DBCS characters written to Error Identification records.

NUM NUM causes the compiler to use the contents of columns 1-6 in the source records for line numbering, rather than using generated sequence numbers. Any invalid (nonnumeric) or out-of-sequence numbers are replaced with a number one higher than that of the previous record.

TEST TEST causes additional object text records to be created that also affect the contents of the SYSADATA file.

The SYSADATA fields shown in the following table contain line numbers whose contents differ depending on the NUM|NONUM setting.

Type	Field	Record
0020	AE_LINE	External Symbol record
0030	ATOK_LINE	Token record
0032	AF_STMT	Source Error record
0038	AS_STMT	Source record
0039	AS_REP_EXP_SLIN	COPY REPLACING record
0039	AS_REP_EXP_ELIN	COPY REPLACING record
0042	ASY_STMT	Symbol record
0044	AX_DEFN	Symbol Cross Reference record
0044	AX_STMT	Symbol Cross Reference record

Type	Field	Record
0046	AN_STMT	Nested Program record

The Type 0038 Source record contains two fields that relate to line numbers and record numbers:

- AS_STMT contains the compiler line number in both the NUM and NONUM cases.
- AS_CUR_REC# contains the physical source record number.

These two fields can always be used to correlate the compiler line numbers, used in all the above fields, with physical source record numbers.

The remaining compiler options have no direct effect on the SYSADATA file, but might trigger generation of additional error messages associated with the specific option, such as FLAGSTD or SSRANGE.

“Example: SYSADATA” on page 739

RELATED REFERENCES

“SYSADATA record types”

“COMPILE” on page 316

“EXIT” on page 324

“LANGUAGE” on page 333

“NUMBER” on page 340

“TEST” on page 364

SYSADATA record types

The SYSADATA file contains records classified into different record types. Each type of record provides information about the COBOL program being compiled.

Each record consists of two parts:

- A 12-byte header section, which has the same structure for all record types, and contains the record code that identifies the type of record
- A variable-length data section, which varies by record type

Table 114. SYSADATA record types

Record type	What it does
“Job identification record: X'0000” on page 743	Provides information about the environment used to process the source data
“ADATA identification record: X'0001” on page 744	Provides common information about the records in the SYSADATA file
“Compilation unit start end record: X'0002” on page 744	Marks the beginning and ending of compilation units in a source file
“Options record: X'0010” on page 745	Describes the compiler options used for the compilation
“External symbol record: X'0020” on page 755	Describes all external names in the program, definitions, and references
“Parse tree record: X'0024” on page 755	Defines a node in the parse tree of the program
“Token record: X'0030” on page 771	Defines a source token
“Source error record: X'0032” on page 785	Describes errors in source program statements

Table 114. SYSADATA record types (continued)

Record type	What it does
"Source record: X'0038'" on page 785	Describes a single source line
"COPY REPLACING record: X'0039'" on page 786	Describes an instance of text replacement as a result of a match of COPY. . .REPLACING <i>operand-1</i> with text in the copybook
"Symbol record: X'0042'" on page 787	Describes a single symbol defined in the program. There is one symbol record for each symbol defined in the program.
"Symbol cross-reference record: X'0044'" on page 798	Describes references to a single symbol
"Nested program record: X'0046'" on page 799	Describes the name and nesting level of a program
"Library record: X'0060'" on page 800	Describes the library files and members used from each library
"Statistics record: X'0090'" on page 800	Describes the statistics about the compilation
"EVENTS record: X'0120'" on page 801	EVENTS records provide compatibility with COBOL/370. The record format is identical with that in COBOL/370, with the addition of the standard ADATA header at the beginning of the record and a field indicating the length of the EVENTS record data.

Example: SYSADATA

The following sample shows part of the listing of a COBOL program. If this COBOL program were compiled with the ADATA option, the records produced in the associated data file would be in the sequence shown in the table below.

```

000001      IDENTIFICATION DIVISION.                AD000020
000002      PROGRAM-ID. AD04202.                    AD000030
000003      ENVIRONMENT DIVISION.                   AD000040
000004      DATA DIVISION.                         AD000050
000005      WORKING-STORAGE SECTION.                AD000060
000006      77  COMP3-FLD2 pic S9(3)v9.             AD000070
000007      PROCEDURE DIVISION.                     AD000080
000008      STOP RUN.
```

Type	Description
X'0120'	EVENTS Timestamp record
X'0120'	EVENTS Processor record
X'0120'	EVENTS File-ID record
X'0120'	EVENTS Program record
X'0001'	ADATA Identification record
X'0000'	Job Identification record
X'0010'	Options record
X'0038'	Source record for statement 1
X'0038'	Source record for statement 2
X'0038'	Source record for statement 3
X'0038'	Source record for statement 4
X'0038'	Source record for statement 5

Type	Description
X'0038'	Source record for statement 6
X'0038'	Source record for statement 7
X'0038'	Source record for statement 8
X'0020'	External Symbol record for AD04202
X'0044'	Symbol Cross Reference record for STOP
X'0044'	Symbol Cross Reference record for COMP3-FLD2
X'0044'	Symbol Cross Reference record for AD04202
X'0042'	Symbol record for AD04202
X'0042'	Symbol record for COMP3-FLD2
X'0090'	Statistics record
X'0120'	EVENTS FileEnd record

RELATED REFERENCES
 "SYSADATA record descriptions"

SYSADATA record descriptions

The formats of the records written to the associated data file are shown in the related references below.

In the fields described in each of the record types, these symbols occur:

- C Indicates character (EBCDIC or ASCII) data
- H Indicates 2-byte binary integer data
- F Indicates 4-byte binary integer data
- A Indicates 4-byte binary integer address and offset data
- X Indicates hexadecimal (bit) data or 1-byte binary integer data

No boundary alignments are implied by any data type, and the implied lengths above might be changed by the presence of a length indicator (*Ln*). All integer data is in big-endian or little-endian format depending on the indicator bit in the header flag byte. *Big-endian* format means that bit 0 is always the most significant bit and bit *n* is the least significant bit. *Little-endian* refers to "byte-reversed" integers as seen on Intel processors.

All undefined fields and unused values are reserved.

RELATED REFERENCES
 "Common header section" on page 741
 "Job identification record: X'0000'" on page 743
 "ADATA identification record: X'0001'" on page 744
 "Compilation unit start | end record: X'0002'" on page 744
 "Options record: X'0010'" on page 745
 "External symbol record: X'0020'" on page 755
 "Parse tree record: X'0024'" on page 755
 "Token record: X'0030'" on page 771
 "Source error record: X'0032'" on page 785
 "Source record: X'0038'" on page 785
 "COPY REPLACING record: X'0039'" on page 786

"Symbol record: X'0042'" on page 787
 "Symbol cross-reference record: X'0044'" on page 798
 "Nested program record: X'0046'" on page 799
 "Library record: X'0060'" on page 800
 "Statistics record: X'0090'" on page 800
 "EVENTS record: X'0120'" on page 801

Common header section

The table below shows the format of the header section that is common for all record types. For MVS and VSE, each record is preceded by a 4-byte RDW (record-descriptor word) that is normally used only by access methods and stripped off by download utilities.

Table 115. SYSADATA common header section

Field	Size	Description
Language code	XL1	16 High Level Assembler
		17 COBOL on all platforms
		40 PL/I on supported platforms

Table 115. SYSADATA common header section (continued)

Field	Size	Description
Record type	HL2	The record type, which can be any of the following ones: X'0000' Job Identification record ¹ X'0001' ADATA Identification record X'0002' Compilation unit start/end record X'0010' Options record ¹ X'0020' External Symbol record X'0024' Parse Tree record X'0030' Token record X'0032' Source Error record X'0038' Source record X'0039' COPY REPLACING record X'0042' Symbol record X'0044' Symbol Cross-Reference record X'0046' Nested Program record X'0060' Library record X'0090' Statistics record ¹ X'0120' EVENTS record
Associated data architecture level	XL1	3 Definition level for the header structure
Flag	XL11. ADATA record integers are in little-endian (Intel) format 1 This record is continued in the next record 1111 11.. Reserved for future use
Associated data record edition level	XL1	Used to indicate a new format for a specific record type, usually 0
Reserved	CL4	Reserved for future use

Table 115. **SYSADATA common header section** (continued)

Field	Size	Description
Associated data field length	HL2	The length in bytes of the data following the header
1. When a batch compilation (sequence of programs) is run with the ADATA option, there will be multiple Job Identification, Options, and Statistics records for each compilation.		

The mapping of the 12-byte header does not include the area used for the variable-length record-descriptor word required by the access method on MVS and VSE.

Job identification record: X'0000'

The following table shows the contents of the job identification record.

Table 116. **SYSADATA job identification record**

Field	Size	Description
Date	CL8	The date of the compilation in the format YYYYMMDD
Time	CL4	The time of the compilation in the format HHMM
Product number	CL8	The product number of the compiler that produced the associated data file
Product version	CL8	The version number of the product that produced the associated data file, in the form V.R.M
PTF level	CL8	The PTF level number of the product that produced the associated data file. (This field is blank if the PTF number is not available.)
System ID	CL24	The system identification of the system on which the compilation was run
Job name	CL8	The MVS job name of the compilation job
Step name	CL8	The MVS step name of the compilation step
Proc step	CL8	The MVS procedure step name of the compilation procedure
Number of input files ¹	HL2	The number of input files recorded in this record. The following group of seven fields will occur <i>n</i> times depending on the value in this field.
...Input file number	HL2	The assigned sequence number of the file
...Input file name length	HL2	The length of the following input file name
...Volume serial number length	HL2	The length of the volume serial number
...Member name length	HL2	The length of the member name
...Input file name	CL(<i>n</i>)	The name of the input file for the compilation
...Volume serial number	CL(<i>n</i>)	The volume serial number of the (first) volume on which the input file resides
...Member name	CL(<i>n</i>)	Where applicable, the name of the member in the input file

Table 116. SYSADATA job identification record (continued)

Field	Size	Description
		1. Where the number of input files would exceed the record size for the associated data file, the record is continued on the next record. The current number of input files (for that record) is stored in the record, and the record is written to the associated data file. The next record contains the rest of the input files. The count of the number of input files is a count for the current record.

ADATA identification record: X'0001'

The following table shows the contents of the ADATA identification record.

Table 117. ADATA identification record

Field	Size	Description
Time (binary)	XL8	Universal Time (UT) as a binary number of microseconds since midnight Greenwich Mean Time, with the low-order bit representing 1 microsecond. This time can be used as a time-zone-independent time stamp. On Windows and AIX systems, only bytes 5-8 of the field are used as a fullword binary field that contains the time.
CCSID ¹	XL2	Coded Character Set Identifier
Character-set flags	XL1	X'80' EBCDIC (IBM-037) X'40' ASCII (IBM-1252)
Code-page name length	XL2	Length of the code-page name that follows
Code-page name	CL(<i>n</i>)	Name of the code page
		1. The appropriate CCS flag will always be set. If the CCSID is set to nonzero, the code-page name length will be zero. If the CCSID is set to zero, the code-page name length will be nonzero and the code-page name will be present.

Compilation unit start | end record: X'0002'

The following table shows the contents of the compilation unit start | end record.

Table 118. SYSADATA compilation unit start | end record

Field	Size	Description
Type	HL2	Compilation unit type, which is one of the following options: X'0000' Start compilation unit X'0001' End compilation unit
Reserved	CL2	Reserved for future use
Reserved	FL4	Reserved for future use

Options record: X'0010'

The following table shows the contents of the options record.

Table 119. SYSADATA options record

Field	Size	Description
Option byte 0	XL1	1111 1111 Reserved for future use
Option byte 1	XL1	<p>1... .. Bit 1 = DECK, Bit 0 = NODECK</p> <p>.1.. Bit 1 = ADATA, Bit 0 = NOADATA</p> <p>..1. Bit 1 = COLLSEQ(EBCDIC), Bit 0 = COLLSEQ(LOCALE BINARY) (Windows and AIX only)</p> <p>...1 Bit 1 = SEPOBJ, Bit 0 = NOSEPOBJ (Windows and AIX only)</p> <p>.... 1... Bit 1 = NAME, Bit 0 = NONAME</p> <p>.... .1.. Bit 1 = OBJECT, Bit 0 = NOOBJECT</p> <p>.... ..1. Bit 1 = SQL, Bit 0 = NOSQL</p> <p>.... ...1 Bit 1 = CICS, Bit 0 = NOCICS</p>
Option byte 2	XL1	<p>1... .. Bit 1 = OFFSET, Bit 0 = NOOFFSET</p> <p>.1.. Bit 1 = MAP, Bit 0 = NOMAP</p> <p>..1. Bit 1 = LIST, Bit 0 = NOLIST</p> <p>...1 Bit 1 = DBCSXREF, Bit 0 = NOBCSXREF</p> <p>.... 1... Bit 1 = XREF(SHORT), Bit 0 = not XREF(SHORT). This flag should be used in combination with the flag at bit 7. XREF(FULL) is indicated by this flag being off and the flag at bit 7 being on.</p> <p>.... .1.. Bit 1 = SOURCE, Bit 0 = NOSOURCE</p> <p>.... ..1. Bit 1 = VBREF, Bit 0 = NOVREF</p> <p>.... ...1 Bit 1 = XREF, Bit 0 = not XREF. See also flag at bit 4 above.</p>

Table 119. SYSADATA options record (continued)

Field	Size	Description
Option byte 3	XL1	<p>1... .. Bit 1 = FLAG imbedded diagnostics level specified (a value <i>y</i> is specified as in FLAG(<i>x,y</i>))</p> <p>.1.. Bit 1 = FLAGSTD, Bit 0 = NOFLAGSTD</p> <p>..1. Bit 1 = NUM, Bit 0 = NONUM</p> <p>...1 Bit 1 = SEQUENCE, Bit 0 = NOSEQUENCE</p> <p>.... 1... Bit 1 = SOSI, Bit 0 = NOSOSI (Windows and AIX only)</p> <p>.... .1.. Bit 1 = NSYMBOL(NATIONAL), Bit 0 = NSYMBOL(DBCS)</p> <p>.... ..1. Bit 1 = PROFILE, Bit 0 = NOPROFILE (AIX only)</p> <p>.... ...1 Bit 1 = WORD, Bit 0 = NOWORD</p>
Option byte 4	XL1	<p>1... .. Bit 1 = ADV, Bit 0 = NOADV</p> <p>.1.. Bit 1 = APOST, Bit 0 = QUOTE</p> <p>..1. Bit 1 = DYNAM, Bit 0 = NODYNAM</p> <p>...1 Bit 1 = AWO, Bit 0 = NOAWO</p> <p>.... 1... Bit 1 = RMODE specified, Bit 0 = RMODE(AUTO)</p> <p>.... .1.. Bit 1 = RENT, Bit 0 = NORENT</p> <p>.... ..1. Bit 1 = RES: this flag will always be set on for COBOL.</p> <p>.... ...1 Bit 1 = RMODE(24), Bit 0 = RMODE(ANY)</p>

Table 119. SYSADATA options record (continued)

Field	Size	Description
Option byte 5	XL1	<p>1... .. Bit 1 = SQLCCSID, Bit 0 = NOSQLCCSID</p> <p>.1.. Bit 1 = OPT(1 2), Bit 0 = OPT(0)</p> <p>..1. Bit 1 = SQLIMS, Bit 0 = NOSQLIMS</p> <p>...1 Bit 1 = DBCS, Bit 0 = NODBCS</p> <p>.... 1... Bit 1 = AFP(VOLATILE), Bit 0 = AFP(NOVOLATILE)</p> <p>.... .1.. Bit 1 = SSRANGE, Bit 0 = NOSSRANGE</p> <p>.... ..1. Bit 1 = TEST, Bit 0 = NOTEST</p> <p>.... ...1 Bit 1 = PROBE, Bit 0 = NOPROBE (Windows only)</p>
Option byte 6	XL1	<p>1... .. Bit 1 = SRCFORMAT(EXTEND), Bit 0 = SRCFORMAT(COMPAT)</p> <p>..1. Bit 1 = NUMPROC(PFD), Bit 0 = NUMPROC(NOPFD)</p> <p>...1 Bit 1 = NUMCLS(ALT), Bit 0 = NUMCLS(PRIM)</p> <p>.... .1.. Bit 1 = BINARY(S390), Bit 0 = BINARY(NATIVE) (Windows and AIX only)</p> <p>.... ..1. Bit 1 = TRUNC(STD), Bit 0 = TRUNC(OPT)</p> <p>.... ...1 Bit 1 = ZWB, Bit 0 = NOZWB</p> <p>.1.. 1... Reserved for future use</p>
Option byte 7	XL1	<p>1... .. Bit 1 = ALLOWCBL, Bit 0 = NOALLOWCBL</p> <p>.1.. Bit 1 = TERM, Bit 0 = NOTERM</p> <p>..1. Bit 1 = DUMP, Bit 0 = NODUMP</p> <p>.... ..1. Bit 1 = CURRENCY, Bit 0 = NOCURRENCY</p> <p>...1 11.1 Reserved for future use</p>

Table 119. SYSADATA options record (continued)

Field	Size	Description
Option byte 8	XL1	<p>1... .. Bit 1 = RULES, Bit 0 = NORULES</p> <p>.1.. Bit 1 = OPTFILE, Bit 0 = not OPTFILE</p> <p>..1. Bit 1 = ADDR(64), Bit 0 = ADDR(32) (AIX only)</p> <p>.... 1... Bit 1 = BLOCK0, Bit 0 = NOBLOCK0</p> <p>.... ..1. Bit 1 = DISPSIGN(SEP), Bit 0 = DISPSIGN(COMPAT)</p> <p>.... ...1 Bit 1 = STGOPT, Bit 0 = NOSTGOPT</p> <p>1..1 .1.. Reserved for future use</p>
Option byte 9	XL1	<p>1... .. Bit 1 = DATA(24), Bit 0 = DATA(31)</p> <p>.1.. Bit 1 = FASTSRT, Bit 0 = NOFASTSRT</p> <p>.... .1.. Bit 1 = THREAD, Bit 0 = NOTHREAD</p> <p>..11 1.11 Reserved for future use</p>
Option byte A	XL1	<p>1... .. Bit 1 = HGPR(PRESERVE), Bit 0 = HGPR(NOPRESERVE)</p> <p>.1.. Bit 1 = XMLPARSE(XMLSS), Bit 0 = XMLPARSE(COMPAT)</p> <p>..1. Bit 1 = MAP(DEC), Bit 0 = MAP(HEX)</p> <p>...1 1... Reserved for future use</p> <p>.... .1.. Bit 1 = VSAMOPENFS(SUCC), BIT 0 = VSAMOPENFS(COMPAT)</p> <p>.... ..11 Reserved for future use</p>
Option byte B	XL1	<p>1111 1111 Reserved for future use</p>

Table 119. SYSADATA options record (continued)

Field	Size	Description
Option byte C	XL1	<p>1... .. Bit 1 = NCOLLSEQ(LOCALE) (Windows and AIX only)</p> <p>.1... .. Reserved for future use</p> <p>..1. Bit 1 = INTDATE(LILIAN), Bit 0 = INTDATE(ANSI)</p> <p>...1 Bit 1 = NCOLLSEQ(BINARY) (Windows and AIX only)</p> <p>.... 1... Bit 1 = CHAR(EBCDIC), Bit 0 = CHAR(NATIVE) (Windows and AIX only)</p> <p>.... .1.. Bit 1 = FLOAT(HEX), Bit 0 = FLOAT(NATIVE) (Windows and AIX only)</p> <p>.... ..1. Bit 1 = COLLSEQ(BINARY) (Windows and AIX only)</p> <p>.... ...1 Bit 1 = COLLSEQ(LOCALE) (Windows and AIX only)</p>
Option byte D	XL1	<p>1... .. Bit 1 = DLL, Bit 0 = NODLL</p> <p>.1... .. Bit 1 = EXPORTALL, Bit 0 = NOEXPORTALL</p> <p>..1. Bit 1 = CODEPAGE</p> <p>...1 Bit 1 = SOURCEFORMAT(EXTEND), Bit 0 = SOURCEFORMAT(COMPAT) (Windows and AIX only)</p> <p>.... ..1. Bit 1 = WSCLEAR, Bit 0 = NOWSCLEAR (Windows and AIX only)</p> <p>.... ...1 Bit 1 = BEOPT, Bit 0 = NOBEOPT (Windows and AIX only)</p> <p>.... 11.. Reserved for future use</p>

Table 119. SYSADATA options record (continued)

Field	Size	Description
Option byte E	XL1	<p>1..... Bit 1 = VLR(COMPAT), Bit 0 = VLR(STANDARD)</p> <p>.1.. Bit 1 = DIAGTRUNC, Bit 0 = NODIAGTRUNC</p> <p>.... .1.. Bit 1 = LSTFILE(UTF-8), Bit 0 = LSTFILE(LOCALE) (Windows and AIX only)</p> <p>.... ..1. Bit 1 = MDECK, Bit 0 = NOMDECK</p> <p>.... ...1 Bit 1 = MDECK(NOCOMPILE)</p> <p>..11 1... Reserved for future use</p>
Option byte F	XL1	<p>1... Bit 1 = DIVIDE(S390), Bit 0 = DIVIDE(NATIVE) (AIX Only)</p> <p>.1.. Bit 1 = COPYRIGHT, Bit 0 = NOCOPYRIGHT</p> <p>..1. Bit 1 = QUALIFY(EXTEND), Bit 0 = QUALIFY(COMPAT)</p> <p>...1 Bit 1 = SERVICE, Bit 0 = NOSERVICE</p> <p>.... 1... Bit 1 = ZONEDATA(MIG)</p> <p>.... .1.. Bit 1 = ZONEDATA(NOPFD)</p> <p>.... ..1. Bit 1 = NUMCHECK(ZON PAC BIN ABD MSG), Bit 0 = NONUMCHECK</p> <p>.... ..111 Reserved for future use</p>
Option byte G	XL1	<p>1... Bit 1 = NUMCHECK(ZON), Bit 0 = NUMCHECK(NOZON)</p> <p>.1.. Bit 1 = NUMCHECK(PAC), Bit 0 = NUMCHECK(NOPAC)</p> <p>..1. Bit 1 = NUMCHECK(BIN), Bit 0 = NUMCHECK(NOBIN)</p> <p>...1 Bit 1 = NUMCHECK(MSG), Bit 0 = NUMCHECK(ABD)</p> <p>.... 1... Bit 1 = NUMCHECK(ZON(NOALPHNUM)), Bit 0 = NUMCHECK(ZON(ALPHNUM))</p> <p>.... ..111 Reserved for future use</p>

Table 119. SYSADATA options record (continued)

Field	Size	Description
Flag level	XL1	X'00' Flag(I) X'04' Flag(W) X'08' Flag(E) X'0C' Flag(S) X'10' Flag(U) X'FF' Noflag
Imbedded diagnostic level	XL1	X'00' Flag(I) X'04' Flag(W) X'08' Flag(E) X'0C' Flag(S) X'10' Flag(U) X'FF' Noflag
FLAGSTD (FIPS) specification	XL1	1... .. Minimum .1.. .. Intermediate ..1. High ...1 IBM extensions 1... Level-1 segmentation1.. Level-2 segmentation1. Debugging1 Obsolete
Reserved for flagging	XL1	1111 1111 Reserved for future use
Compiler mode	XL1	X'00' Unconditional Nocompile, Nocompile(I) X'04' Nocompile(W) X'08' Nocompile(E) X'0C' Nocompile(S) X'FF' Compile
Space value	CL1	

Table 119. SYSADATA options record (continued)

Field	Size	Description
Data for 3-valued options	XL1	<p>1... .. NAME(ALIAS) specified</p> <p>.1.. .. Reserved for future use</p> <p>..1. TRUNC(BIN) specified</p> <p>...1 1111 Reserved for future use</p>
TEST suboptions	XL1	<p>..1. TEST(EJPD)</p> <p>...1 TEST(SOURCE)</p> <p>11.. 1111 Reserved for TEST suboptions</p>
OUTDD name length	HL2	Length of OUTDD name
RWT ID Length	HL2	Length of Reserved Word Table identifier
LVLINFO	CL8	User-specified LVLINFO data
PGMNAME suboptions	XL1	<p>1... .. Bit 1 = PGMNAME(COMPAT)</p> <p>.1.. .. Bit 1 = PGMNAME(LONGUPPER)</p> <p>..1. Bit 1 = PGMNAME(LONGMIXED)</p> <p>...1 1111 Reserved for future use</p>
Entry interface suboptions	XL1	<p>1... .. Bit 1 = EntryInterface(System) (Windows only)</p> <p>.1.. .. Bit 1 = EntryInterface(OptLink) (Windows only)</p> <p>..11 1111 Reserved for future use</p>
CALLINTERFACE suboptions	XL1	<p>1... .. Bit 1 = CALLINTERFACE(DLL)</p> <p>.1.. .. Bit 1 = CALLINTERFACE(DYNAMIC)</p> <p>..11 1111 Reserved for future use</p>
ARITH suboption	XL1	<p>1... .. Bit 1 = ARITH(COMPAT)</p> <p>.1.. .. Bit 1 = ARITH(EXTEND)</p> <p>..11 1111 Reserved for future use</p>

Table 119. SYSADATA options record (continued)

Field	Size	Description
DBCS Req	FL4	DBCS XREF storage requirement
DBCS ORDPGM length	HL2	Length of name of DBCS Ordering Program
DBCS ENCTBL length	HL2	Length of name of DBCS Encode Table
DBCS ORD TYPE	CL2	DBCS Ordering type
Reserved	CL5	Reserved for future use
Optimize level	XL1	Optimization level $0 \leq n \leq 2$
Converted SO	CL1	Converted SO hexadecimal value
Converted SI	CL1	Converted SI hexadecimal value
Language ID	CL2	This field holds the two-character abbreviation (one of <i>EN</i> , <i>UE</i> , <i>JA</i> , or <i>JP</i>) from the LANGUAGE option.
Reserved	CL8	Reserved for future use
INEXIT name length	HL2	Length of SYSIN user-exit name
PRTEXIT name length	HL2	Length of SYSPRINT user-exit name
LIBEXIT name length	HL2	Length of Libraryuser-exit name
ADEXIT name length	HL2	Length of ADATA user-exit name
CURROPT	CL5	CURRENCY option value
ARCH	XL1	ARCH level number
Reserved	CL2	Reserved for future use
CODEPAGE	HL2	CODEPAGE CCSID option value
Reserved	CL50	Reserved for future use
LINECNT	HL2	LINECOUNT value
Reserved	CL2	Reserved for future use
BUFSIZE	FL4	BUFSIZE option value
Reserved	FL4	Reserved for future use
Phase residence bits byte 1	XL1	<p>1... .. Bit 1 = IGYCLIBR in user region</p> <p>.1.. .. Bit 1 = IGYCSCAN in user region</p> <p>..1. Bit 1 = IGYCDSCN in user region</p> <p>...1 Bit 1 = IGYCGROU in user region</p> <p>.... 1... Bit 1 = IGYCPSCN in user region</p> <p>.... .1.. Bit 1 = IGYCPANA in user region</p> <p>.... ..1. Bit 1 = IGYCFGEN in user region</p> <p>.... ...1 Bit 1 = IGYCPGEN in user region</p>

Table 119. SYSADATA options record (continued)

Field	Size	Description
Phase residence bits byte 2	XL1	.1.. Bit 1 = IGYCLSTR in user region ..1. Bit 1 = IGYCXREF in user region ...1 Bit 1 = IGYCDMAP in user region 1. Bit 1 = IGYCDIAG in user region 1 Bit 1 = IGYCDGEN in user region 1... 11.. Reserved for future use
Phase residence bits bytes 3 and 4	XL2	Reserved
Reserved	CL8	Reserved for future use
OUTDD name	CL(<i>n</i>)	OUTDD name
RWT	CL(<i>n</i>)	Reserved word table identifier
DBCS ORDPGM	CL(<i>n</i>)	DBCS Ordering program name
DBCS ENCTBL	CL(<i>n</i>)	DBCS Encode table name
INEXIT name	CL(<i>n</i>)	SYSIN user-exit name
PRTEXT name	CL(<i>n</i>)	SYSPRINT user-exit name
LIBEXIT name	CL(<i>n</i>)	Library user-exit name
ADEXIT name	CL(<i>n</i>)	ADATA user-exit name

External symbol record: X'0020'

The following table shows the contents of the external symbol record.

Table 120. SYSADATA external symbol record

Field	Size	Description
Section type	XL1	X'00' PROGRAM-ID name (main entry point name) X'01' ENTRY name (secondary entry point name) X'02' External reference (referenced external entry point) X'04' Not applicable for COBOL X'05' Not applicable for COBOL X'06' Not applicable for COBOL X'0A' Not applicable for COBOL X'12' Internal reference (referenced internal subprogram) X'C0' External class-name (OO COBOL class definition) X'C1' METHOD-ID name (OO COBOL method definition) X'C6' Method reference (OO COBOL method reference) X'FF' Not applicable for COBOL Types X'12', X'C0', X'C1' and X'C6' are for COBOL only.
Flags	XL1	Not applicable for COBOL
Reserved	HL2	Reserved for future use
Symbol-ID	FL4	Symbol-ID of program that contains the reference (only for types x'02' and x'12')
Line number	FL4	Line number of statement that contains the reference (only for types x'02' and x'12')
Section length	FL4	Not applicable for COBOL
LD ID	FL4	Not applicable for COBOL
Reserved	CL8	Reserved for future use
External name length	HL2	Number of characters in the external name
Alias name length	HL2	Not applicable for COBOL
External name	CL(<i>n</i>)	The external name
Alias section name	CL(<i>n</i>)	Not applicable for COBOL

Parse tree record: X'0024'

The following table shows the contents of the parse tree record.

Table 121. SYSADATA parse tree record

Field	Size	Description
Node number	FL4	The node number generated by the compiler, starting at 1

Table 121. SYSADATA parse tree record (continued)

Field	Size	Description
Node type	HL2	The type of the node:
		001 Program
		002 Class
		003 Method
		101 IDENTIFICATION DIVISION
		102 ENVIRONMENT DIVISION
		103 DATA DIVISION
		104 PROCEDURE DIVISION
		105 End Program/Method/Class
		201 Declaratives body
		202 Nondeclaratives body
		301 Section
		302 Procedure section
		401 Paragraph
		402 Procedure paragraph
		501 Sentence
		502 File definition
		503 Sort file definition
		504 Program-name
		505 Program attribute
		508 ENVIRONMENT DIVISION clause
		509 CLASS attribute
		510 METHOD attribute
		511 USE statement
		601 Statement
		602 Data description clause
		603 Data entry
		604 File description clause
		605 Data entry name
		606 Data entry level
		607 EXEC entry

Table 121. SYSADATA parse tree record (continued)

Field	Size	Description
		701 EVALUATE subject phrase
		702 EVALUATE WHEN phrase
		703 EVALUATE WHEN OTHER phrase
		704 SEARCH WHEN phrase
		705 INSPECT CONVERTING phrase
		706 INSPECT REPLACING phrase
		707 INSPECT TALLYING phrase
		708 PERFORM UNTIL phrase
		709 PERFORM VARYING phrase
		710 PERFORM AFTER phrase
		711 Statement block
		712 Scope terminator
		713 INITIALIZE REPLACING phrase
		714 EXEC CICS Command
		720 DATA DIVISION phrase
		801 Phrase
		802 ON phrase
		803 NOT phrase
		804 THEN phrase
		805 ELSE phrase
		806 Condition
		807 Expression
		808 Relative indexing
		809 EXEC CICS Option
		810 Reserved word
		811 INITIALIZE REPLACING category

Table 121. SYSADATA parse tree record (continued)

Field	Size	Description
		901 Section or paragraph name 902 Identifier 903 Alphabet-name 904 Class-name 905 Condition-name 906 File-name 907 Index-name 908 Mnemonic-name 910 Symbolic-character 911 Literal 912 Function identifier 913 Data-name 914 Special register 915 Procedure reference 916 Arithmetic operator 917 All procedures 918 INITIALIZE literal (no tokens) 919 ALL literal or figcon 920 Keyword class test name 921 Reserved word at identifier level 922 Unary operator 923 Relational operator
		1001 Subscript 1002 Reference modification
Node subtype	HL2	The subtype of the node. For Section type: 0001 CONFIGURATION Section 0002 INPUT-OUTPUT Section 0003 FILE SECTION 0004 WORKING-STORAGE SECTION 0005 LINKAGE SECTION 0006 LOCAL-STORAGE SECTION 0007 REPOSITORY Section

Table 121. SYSADATA parse tree record (continued)

Field	Size	Description
		For Paragraph type: 0001 PROGRAM-ID paragraph 0002 AUTHOR paragraph 0003 INSTALLATION paragraph 0004 DATE-WRITTEN paragraph 0005 SECURITY paragraph 0006 SOURCE-COMPUTER paragraph 0007 OBJECT-COMPUTER paragraph 0008 SPECIAL-NAMES paragraph 0009 FILE-CONTROL paragraph 0010 I-O-CONTROL paragraph 0011 DATE-COMPILED paragraph 0012 CLASS-ID paragraph 0013 METHOD-ID paragraph 0014 REPOSITORY paragraph
		For ENVIRONMENT DIVISION clause type: 0001 WITH DEBUGGING MODE 0002 MEMORY-SIZE 0003 SEGMENT-LIMIT 0004 CURRENCY-SIGN 0005 DECIMAL POINT 0006 PROGRAM COLLATING SEQUENCE 0007 ALPHABET 0008 SYMBOLIC-CHARACTER 0009 CLASS 0010 ENVIRONMENT NAME 0011 SELECT 0012 XML-SCHEMA

Table 121. SYSADATA parse tree record (continued)

Field	Size	Description
		For data description clause type:
		0001 BLANK WHEN ZERO
		0002 DATA-NAME OR FILLER
		0003 JUSTIFIED
		0004 OCCURS
		0005 PICTURE
		0006 REDEFINES
		0007 RENAMES
		0008 SIGN
		0009 SYNCHRONIZED
		0010 USAGE
		0011 VALUE
		0012 VOLATILE
		0023 GLOBAL
		0024 EXTERNAL

|

Table 121. SYSADATA parse tree record (continued)

Field	Size	Description
		For file description clause type:
		0001 FILE STATUS
		0002 ORGANIZATION
		0003 ACCESS MODE
		0004 RECORD KEY
		0005 ASSIGN
		0006 RELATIVE KEY
		0007 PASSWORD
		0008 PROCESSING MODE
		0009 RECORD DELIMITER
		0010 PADDING CHARACTER
		0011 BLOCK CONTAINS
		0012 RECORD CONTAINS
		0013 LABEL RECORDS
		0014 VALUE OF
		0015 DATA RECORDS
		0016 LINAGE
		0017 ALTERNATE KEY
		0018 LINES AT TOP
		0019 LINES AT BOTTOM
		0020 CODE-SET
		0021 RECORDING MODE
		0022 RESERVE
		0023 GLOBAL
		0024 EXTERNAL
		0025 LOCK

Table 121. SYSADATA parse tree record (continued)

Field	Size	Description
		For Statement type:
		0002 NEXT SENTENCE
		0003 ACCEPT
		0004 ADD
		0005 ALTER
		0006 CALL
		0007 CANCEL
		0008 CLOSE
		0009 COMPUTE
		0010 CONTINUE
		0011 DELETE
		0012 DISPLAY
		0013 DIVIDE (INTO)
		0113 DIVIDE (BY)
		0014 ENTER
		0015 ENTRY
		0016 EVALUATE
		0017 EXIT
		0018 GO
		0019 GOBACK
		0020 IF
		0021 INITIALIZE
		0022 INSPECT

Table 121. SYSADATA parse tree record (continued)

Field	Size	Description
		0023 INVOKE
		0024 MERGE
		0025 MOVE
		0026 MULTIPLY
		0027 OPEN
		0028 PERFORM
		0029 READ
		0030 READY
		0031 RELEASE
		0032 RESET
		0033 RETURN
		0034 REWRITE
		0035 SEARCH
		0036 SERVICE
		0037 SET
		0038 SORT
		0039 START
		0040 STOP
		0041 STRING
		0042 SUBTRACT
		0043 UNSTRING
		0044 EXEC SQL
		0144 EXEC CICS
		0045 WRITE
		0046 XML

Table 121. SYSADATA parse tree record (continued)

Field	Size	Description
		For Phrase type:
		0001 INTO
		0002 DELIMITED
		0003 INITIALIZE. .REPLACING
		0004 INSPECT. .ALL
		0005 INSPECT. .LEADING
		0006 SET. .TO
		0007 SET. .UP
		0008 SET. .DOWN
		0009 PERFORM. .TIMES
		0010 DIVIDE. .REMAINDER
		0011 INSPECT. .FIRST
		0012 SEARCH. .VARYING
		0013 MORE-LABELS
		0014 SEARCH ALL
		0015 SEARCH. .AT END
		0016 SEARCH. .TEST INDEX
		0017 GLOBAL
		0018 LABEL
		0019 DEBUGGING
		0020 SEQUENCE
		0021 Reserved for future use
		0022 Reserved for future use
		0023 Reserved for future use
		0024 TALLYING
		0025 Reserved for future use
		0026 ON SIZE ERROR
		0027 ON OVERFLOW
		0028 ON ERROR
		0029 AT END
		0030 INVALID KEY
		0031 END-OF-PAGE
		0032 USING

Table 121. SYSADATA parse tree record (continued)

Field	Size	Description
		0033 BEFORE
		0034 AFTER
		0035 EXCEPTION
		0036 CORRESPONDING
		0037 Reserved for future use
		0038 RETURNING
		0039 GIVING
		0040 THROUGH
		0041 KEY
		0042 DELIMITER
		0043 POINTER
		0044 COUNT
		0045 METHOD
		0046 PROGRAM
		0047 INPUT
		0048 OUTPUT
		0049 I-O
		0050 EXTEND
		0051 RELOAD
		0052 ASCENDING
		0053 DESCENDING
		0054 DUPLICATES
		0055 NATIVE (USAGE)
		0056 INDEXED
		0057 FROM
		0058 FOOTING
		0059 LINES AT BOTTOM
		0060 LINES AT TOP
		0061 XML ENCODING
		0062 XML GENERATE XML-DECLARATION
		0063 XML GENERATE ATTRIBUTES
		0064 XML GENERATE NAMESPACE
		0065 XML PARSE PROCESSING
		0066 XML PARSE VALIDATING
		0067 XML GENERATE NAME
		0068 XML GENERATE TYPE
		0069 XML GENERATE SUPPRESS

Table 121. SYSADATA parse tree record (continued)

Field	Size	Description
		For Function identifier type:
		0001 COS
		0002 LOG
		0003 MAX
		0004 MIN
		0005 MOD
		0006 ORD
		0007 REM
		0008 SIN
		0009 SUM
		0010 TAN
		0011 ACOS
		0012 ASIN
		0013 ATAN
		0014 CHAR
		0015 MEAN
		0016 SQRT
		0017 LOG10
		0018 RANGE
		0019 LENGTH
		0020 MEDIAN
		0021 NUMVAL
		0022 RANDOM
		0023 ANNUITY
		0024 INTEGER
		0025 ORD-MAX
		0026 ORD-MIN
		0027 REVERSE
		0028 MIDRANGE
		0029 NUMVAL-C
		0030 VARIANCE
		0031 FACTORIAL
		0032 LOWER-CASE

Table 121. SYSADATA parse tree record (continued)

Field	Size	Description
		0033 UPPER-CASE 0034 CURRENT-DATE 0035 INTEGER-PART 0036 PRESENT-VALUE 0037 WHEN-COMPILED 0038 DAY-OF-INTEGERS 0039 INTEGER-OF-DAY 0040 DATE-OF-INTEGERS 0041 INTEGER-OF-DATE 0042 STANDARD-DEVIATION 0043 YEAR-TO-YYYY 0044 DAY-TO-YYYYDDD 0045 DATE-TO-YYYYMMDD 0049 DISPLAY-OF 0050 NATIONAL-OF 0051 UPOS 0052 UVALID 0053 UWIDTH 0054 ULENGTH 0055 USUBSTR 0056 USUPPLEMENTARY
		For Special Register type: 0001 ADDRESS OF 0002 LENGTH OF
		For Keyword Class Test Name type: 0001 ALPHABETIC 0002 ALPHABETIC-LOWER 0003 ALPHABETIC-UPPER 0004 DBCS 0005 KANJI 0006 NUMERIC 0007 NEGATIVE 0008 POSITIVE 0009 ZERO

Table 121. SYSADATA parse tree record (continued)

Field	Size	Description
		For Reserved Word type: 0001 TRUE 0002 FALSE 0003 ANY 0004 THRU
		For Identifier, Data-name, Index-name, Condition-name or Mnemonic-name type: 0001 REFERENCED 0002 CHANGED 0003 REFERENCED & CHANGED
		For Initialize literal type: 0001 ALPHABETIC 0002 ALPHANUMERIC 0003 NUMERIC 0004 ALPHANUMERIC-EDITED 0005 NUMERIC-EDITED 0006 DBCS/EGCS 0007 NATIONAL 0008 NATIONAL-EDITED
		For Procedure-name type: 0001 SECTION 0002 PARAGRAPH

Table 121. SYSADATA parse tree record (continued)

Field	Size	Description
		For Reserved word at identifier level type:
		0001 ROUNDED
		0002 TRUE
		0003 ON
		0004 OFF
		0005 SIZE
		0006 DATE
		0007 DAY
		0008 DAY-OF-WEEK
		0009 TIME
		0010 WHEN-COMPILED
		0011 PAGE
		0012 DATE YYYYMMDD
		0013 DAY YYYYDDD
		0014 Attribute
		0015 Element
		0016 Content
		0017 Numeric
		0018 Nonnumeric
		0019 Every
		0020 When
		For Arithmetic Operator type:
		0001 PLUS
		0002 MINUS
		0003 TIMES
		0004 DIVIDE
		0005 DIVIDE REMAINDER
		0006 EXPONENTIATE
		0007 NEGATE

Table 121. SYSADATA parse tree record (continued)

Field	Size	Description
		<p>For Relational Operator type:</p> <p>0008 LESS</p> <p>0009 LESS OR EQUAL</p> <p>0010 EQUAL</p> <p>0011 NOT EQUAL</p> <p>0012 GREATER</p> <p>0013 GREATER OR EQUAL</p> <p>0014 AND</p> <p>0015 OR</p> <p>0016 CLASS CONDITION</p> <p>0017 NOT CLASS CONDITION</p>
Parent node number	FL4	The node number of the parent of the node
Left sibling node number	FL4	The node number of the left sibling of the node, if any. If none, the value is zero.
Symbol ID	FL4	<p>The Symbol ID of the node, if it is a user-name of one of the following types:</p> <ul style="list-style-type: none"> • Data entry • Identifier • File-name • Index-name • Procedure-name • Condition-name • Mnemonic-name <p>This value corresponds to the Symbol ID in a Symbol (Type 42) record, except for procedure-names where it corresponds to the Paragraph ID.</p> <p>For all other node types this value is zero.</p>
Section Symbol ID	FL4	<p>The Symbol ID of the section containing the node, if it is a qualified paragraph-name reference. This value corresponds to the Section ID in a Symbol (Type 42) record.</p> <p>For all other node types this value is zero.</p>
First token number	FL4	The number of the first token associated with the node
Last token number	FL4	The number of the last token associated with the node
Reserved	FL4	Reserved for future use
Flags	CL1	<p>Information about the node:</p> <p>X'80' Reserved</p> <p>X'40' Generated node, no tokens</p>
Reserved	CL3	Reserved for future use

Token record: X'0030'

The compiler does not generate token records for any lines that are treated as comment lines, which include, but are not limited to, items in the following list.

- Comment lines, which are source lines that have an asterisk (*) or a slash (/) in column 7
- The following compiler-directing statements:
 - *CBL (*CONTROL)
 - BASIS
 - COPY
 - DELETE
 - EJECT
 - INSERT
 - REPLACE
 - SKIP1
 - SKIP2
 - SKIP3
 - TITLE
- Debugging lines, which are source lines that have a D in column 7, if WITH DEBUGGING MODE is not specified

Table 122. SYSADATA token record

Field	Size	Description
Token number	FL4	The token number within the source file generated by the compiler, starting at 1. Any copybooks have already been included in the source.

Table 122. SYSADATA token record (continued)

Field	Size	Description
Token code	HL2	<p>The type of token (user-name, literal, reserved word, and so forth).</p> <p>For reserved words, the compiler reserved-word table values are used.</p> <p>For PICTURE strings, the special code 0000 is used.</p> <p>For each piece (other than the last) of a continued token, the special code 3333 is used.</p> <p>Otherwise, the following codes are used:</p> <p>0001 ACCEPT</p> <p>0002 ADD</p> <p>0003 ALTER</p> <p>0004 CALL</p> <p>0005 CANCEL</p> <p>0007 CLOSE</p> <p>0009 COMPUTE</p> <p>0011 DELETE</p> <p>0013 DISPLAY</p> <p>0014 DIVIDE</p> <p>0017 READY</p> <p>0018 END-PERFORM</p> <p>0019 ENTER</p> <p>0020 ENTRY</p> <p>0021 EXIT</p> <p>0022 EXEC</p> <p>EXECUTE</p> <p>0023 GO</p> <p>0024 IF</p> <p>0025 INITIALIZE</p> <p>0026 INVOKE</p> <p>0027 INSPECT</p> <p>0028 MERGE</p> <p>0029 MOVE</p>

Table 122. SYSADATA token record (continued)

Field	Size	Description
		0030 MULTIPLY
		0031 OPEN
		0032 PERFORM
		0033 READ
		0035 RELEASE
		0036 RETURN
		0037 REWRITE
		0038 SEARCH
		0040 SET
		0041 SORT
		0042 START
		0043 STOP
		0044 STRING
		0045 SUBTRACT
		0048 UNSTRING
		0049 USE
		0050 WRITE
		0051 CONTINUE
		0052 END-ADD
		0053 END-CALL
		0054 END-COMPUTE
		0055 END-DELETE
		0056 END-DIVIDE
		0057 END-EVALUATE
		0058 END-IF
		0059 END-MULTIPLY
		0060 END-READ
		0061 END-RETURN
		0062 END-REWRITE
		0063 END-SEARCH
		0064 END-START
		0065 END-STRING
		0066 END-SUBTRACT
		0067 END-UNSTRING
		0068 END-WRITE
		0069 GOBACK

Table 122. SYSADATA token record (continued)

Field	Size	Description
		0070 EVALUATE
		0071 RESET
		0072 SERVICE
		0073 END-INVOKE
		0074 END-EXEC
		0075 XML
		0076 END-XML
		0099 FOREIGN-VERB
		0101 DATA-NAME
		0105 DASHED-NUM
		0106 DECIMAL
		0107 DIV-SIGN
		0108 EQ
		0109 EXPONENTIATION
		0110 GT
		0111 INTEGER
		0112 LT
		0113 LPAREN
		0114 MINUS-SIGN
		0115 MULT-SIGN
		0116 NONUMLIT
		0117 PERIOD
		0118 PLUS-SIGN
		0121 RPAREN
		0122 SIGNED-INTEGER
		0123 QUID
		0124 COLON
		0125 IEOF
		0126 EGCS-LIT
		0127 COMMA-SPACE
		0128 SEMICOLON-SPACE
		0129 PROCEDURE-NAME
		0130 FLT-POINT-LIT
		0131 Language Environment

Table 122. SYSADATA token record (continued)

Field	Size	Description
		0132 GE
		0133 IDREF
		0134 EXPREF
		0136 CICS
		0137 NEW
		0138 NATIONAL-LIT
		0200 ADDRESS
		0201 ADVANCING
		0202 AFTER
		0203 ALL
		0204 ALPHABETIC
		0205 ALPHANUMERIC
		0206 ANY
		0207 AND
		0208 ALPHANUMERIC-EDITED
		0209 BEFORE
		0210 BEGINNING
		0211 FUNCTION
		0212 CONTENT
		0213 CORR
		CORRESPONDING
		0214 DAY
		0215 DATE
		0216 DEBUG-CONTENTS
		0217 DEBUG-ITEM
		0218 DEBUG-LINE
		0219 DEBUG-NAME
		0220 DEBUG-SUB-1
		0221 DEBUG-SUB-2
		0222 DEBUG-SUB-3
		0223 DELIMITED
		0224 DELIMITER
		0225 DOWN

Table 122. SYSADATA token record (continued)

Field	Size	Description
		0226 NUMERIC-EDITED
		0227 XML-EVENT
		0228 END-OF-PAGE EOP
		0229 EQUAL
		0230 ERROR
		0231 XML-NTEXT
		0232 EXCEPTION
		0233 EXTEND
		0234 FIRST
		0235 FROM
		0236 GIVING
		0237 GREATER
		0238 I-O
		0239 IN
		0240 INITIAL
		0241 INTO
		0242 INVALID
		0243 SQL
		0244 LESS
		0245 LINAGE-COUNTER
		0246 XML-TEXT
		0247 LOCK
		0248 GENERATE
		0249 NEGATIVE
		0250 NEXT
		0251 NO
		0252 NOT
		0253 NUMERIC
		0254 KANJI
		0255 OR
		0256 OTHER
		0257 OVERFLOW
		0258 PAGE
		0259 CONVERTING

Table 122. SYSADATA token record (continued)

Field	Size	Description
		0260 POINTER
		0261 POSITIVE
		0262 DBCS
		0263 PROCEDURES
		0264 PROCEED
		0265 REFERENCES
		0266 DAY-OF-WEEK
		0267 REMAINDER
		0268 REMOVAL
		0269 REPLACING
		0270 REVERSED
		0271 REWIND
		0272 ROUNDED
		0273 RUN
		0274 SENTENCE
		0275 STANDARD
		0276 RETURN-CODE
		SORT-CORE-SIZE
		SORT-FILE-SIZE
		SORT-MESSAGE
		SORT-MODE-SIZE
		SORT-RETURN
		TALLY
		XML-CODE
		0277 TALLYING
		0278 SUM
		0279 TEST
		0280 THAN
		0281 UNTIL
		0282 UP
		0283 UPON
		0284 VARYING
		0285 RELOAD
		0286 TRUE

Table 122. SYSADATA token record (continued)

Field	Size	Description
		0287 THEN
		0288 RETURNING
		0289 ELSE
		0290 SELF
		0291 SUPER
		0292 WHEN-COMPILED
		0293 ENDING
		0294 FALSE
		0295 REFERENCE
		0296 NATIONAL-EDITED
		0297 COM-REG
		0298 ALPHABETIC-LOWER
		0299 ALPHABETIC-UPPER
		0301 REDEFINES
		0302 OCCURS
		0303 SYNC
		SYNCHRONIZED
		0304 MORE-LABELS
		0305 JUST
		JUSTIFIED
		0306 SHIFT-IN
		0307 BLANK
		0308 VALUE
		0309 COMP
		COMPUTATIONAL
		0310 COMP-1
		COMPUTATIONAL-1
		0311 COMP-3
		COMPUTATIONAL-3
		0312 COMP-2
		COMPUTATIONAL-2
		0313 COMP-4
		COMPUTATIONAL-4
		0314 DISPLAY-1
		0315 SHIFT-OUT

Table 122. SYSADATA token record (continued)

Field	Size	Description
		0316 INDEX
		0317 USAGE
		0318 SIGN
		0319 LEADING
		0320 SEPARATE
		0321 INDEXED
		0322 LEFT
		0323 RIGHT
		0324 PIC
		PICTURE
		0325 VALUES
		0326 GLOBAL
		0327 EXTERNAL
		0328 BINARY
		0329 PACKED-DECIMAL
		0330 EGCS
		0331 PROCEDURE-POINTER
		0332 COMP-5
		COMPUTATIONAL-5
		0333 FUNCTION-POINTER
		0334 TYPE
		0335 JNIENVPTR
		0336 NATIONAL
		0337 GROUP-USAGE
		0342 VOLATILE
		0401 HIGH-VALUE
		HIGH-VALUES
		0402 LOW-VALUE
		LOW-VALUES
		0403 QUOTE
		QUOTES
		0404 SPACE
		SPACES
		0405 ZERO

I

Table 122. SYSADATA token record (continued)

Field	Size	Description
		0406 ZEROES ZEROS
		0407 NULL NULLS
		0501 BLOCK
		0502 BOTTOM
		0505 CHARACTER
		0506 CODE
		0507 CODE-SET
		0514 FILLER
		0516 FOOTING
		0520 LABEL
		0521 LENGTH
		0524 LINAGE
		0526 OMITTED
		0531 RENAMES
		0543 TOP
		0545 TRAILING
		0549 RECORDING
		0601 INHERITS
		0603 RECURSIVE
		0701 ACCESS
		0702 ALSO
		0703 ALTERNATE
		0704 AREA AREAS
		0705 ASSIGN
		0707 COLLATING
		0708 COMMA
		0709 CURRENCY
		0710 CLASS
		0711 DECIMAL-POINT
		0712 DUPLICATES
		0713 DYNAMIC
		0714 EVERY

Table 122. SYSADATA token record (continued)

Field	Size	Description
		0716 MEMORY
		0717 MODE
		0718 MODULES
		0719 MULTIPLE
		0720 NATIVE
		0721 OFF
		0722 OPTIONAL
		0723 ORGANIZATION
		0724 POSITION
		0725 PROGRAM
		0726 RANDOM
		0727 RELATIVE
		0728 RERUN
		0729 RESERVE
		0730 SAME
		0731 SEGMENT-LIMIT
		0732 SELECT
		0733 SEQUENCE
		0734 SEQUENTIAL
		0736 SORT-MERGE
		0737 STANDARD-1
		0738 TAPE
		0739 WORDS
		0740 PROCESSING
		0741 APPLY
		0742 WRITE-ONLY
		0743 COMMON
		0744 ALPHABET
		0745 PADDING
		0746 SYMBOLIC
		0747 STANDARD-2
		0748 OVERRIDE
		0750 PASSWORD
		0751 XML-SCHEMA

Table 122. SYSADATA token record (continued)

Field	Size	Description
		0801 ARE
		IS
		0802 ASCENDING
		0803 AT
		0804 BY
		0805 CHARACTERS
		0806 CONTAINS
		0808 COUNT
		0809 DEBUGGING
		0810 DEPENDING
		0811 DESCENDING
		0812 DIVISION
		0814 FOR
		0815 ORDER
		0816 INPUT
		0817 REPLACE
		0818 KEY
		0819 LINE
		LINES
		0820 XML-INFORMATION
		0821 OF
		0822 ON
		0823 OUTPUT
		0825 RECORD
		0826 RECORDS
		0827 REEL
		0828 SECTION
		0829 SIZE
		0830 STATUS
		0831 THROUGH
		THRU
		0832 TIME
		0833 TIMES
		0834 TO
		0836 UNIT
		840 SQLIMS

I

Table 122. SYSADATA token record (continued)

Field	Size	Description
		0837 USING
		0838 WHEN
		0839 WITH
		0840 SQLIMS
		0901 PROCEDURE
		0902 DECLARATIVES
		0903 END
		1001 DATA
		1002 FILE
		1003 FD
		1004 SD
		1005 WORKING-STORAGE
		1006 LOCAL-STORAGE
		1007 LINKAGE
		1101 ENVIRONMENT
		1102 CONFIGURATION
		1103 SOURCE-COMPUTER
		1104 OBJECT-COMPUTER
		1105 SPECIAL-NAMES
		1106 REPOSITORY
		1107 INPUT-OUTPUT
		1108 FILE-CONTROL
		1109 I-O-CONTROL
		1201 ID
		IDENTIFICATION
		1202 PROGRAM-ID
		1203 AUTHOR
		1204 INSTALLATION
		1205 DATE-WRITTEN
		1206 DATE-COMPILED
		1207 SECURITY
		1208 CLASS-ID
		1209 METHOD-ID
		1210 METHOD
		1211 FACTORY

Table 122. SYSADATA token record (continued)

Field	Size	Description
		1212 OBJECT
		2020 TRACE
		2046 SUPPRESS
		3000 DATADEF
		3001 F-NAME
		3002 UPSI-SWITCH
		3003 CONDNAME
		3004 CONDVAR
		3005 BLOB
		3006 CLOB
		3007 DBCLOB
		3008 BLOB-LOCATOR
		3009 CLOB-LOCATOR
		3010 DBCLOB-LOCATOR
		3011 BLOB-FILE
		3012 CLOB-FILE
		3013 DBCLOB-FILE
		3014 DFHRESP
		5001 PARSE
		5002 AUTOMATIC
		5003 PREVIOUS
		5004 ENCODING
		5005 NAMESPACE
		5006 NAMESPACE-PREFIX
		5007 XML-DECLARATION
		5008 ATTRIBUTES
		5009 VALIDATING
		5010 UNBOUNDED
		5011 ATTRIBUTE
		5012 ELEMENT
		5013 NONNUMERIC
		5014 NAME
		5015 CYCLE
		5016 PARAGRAPH
		9999 COBOL
Token length	HL2	The length of the token
Token column	FL4	The starting column number of the token in the source listing

Table 122. SYSADATA token record (continued)

Field	Size	Description
Token line	FL4	The line number of the token in the source listing
Flags	CL1	Information about the token: X'80' Token is continued X'40' Last piece of continued token Note that for PICTURE strings, even if the source token is continued, there will be only one Token record generated. It will have a token code of 0000, the token column and line of the first piece, the length of the complete string, no continuation flags set, and the token text of the complete string.
Reserved	CL7	Reserved for future use
Token text	CL(<i>n</i>)	The actual token string

Source error record: X'0032'

The following table shows the contents of the source error record.

Table 123. SYSADATA source error record

Field	Size	Description
Statement number	FL4	The statement number of the statement in error
Error identifier	CL16	The error message identifier (left-justified and padded with blanks)
Error severity	HL2	The severity of the error
Error message length	HL2	The length of the error message text
Line position	XL1	The line position indicator provided in FIPS messages
Reserved	CL7	Reserved for future use
Error message	CL(<i>n</i>)	The error message text

Source record: X'0038'

The following table shows the contents of the source record.

Table 124. SYSADATA source record

Field	Size	Description
Line number	FL4	The listing line number of the source record
Input record number	FL4	The input source record number in the current input file
Primary file number	HL2	The input file's assigned sequence number if this record is from the primary input file. (Refer to the Input file <i>n</i> field in the Job identification record).
Library file number	HL2	The library input file's assigned sequence number if this record is from a COPY BASIS input file. (Refer to the Member File ID <i>n</i> field in the Library record.)
Reserved	CL8	Reserved for future use
Parent record number	FL4	The parent source record number. This will be the record number of the COPY BASIS statement.

Table 124. SYSADATA source record (continued)

Field	Size	Description
Parent primary file number	HL2	The parent file's assigned sequence number if the parent of this record is from the primary input file. (Refer to the Input file <i>n</i> field in the Job Identification Record.)
Parent library assigned file number	HL2	The parent library file's assigned sequence number if this record's parent is from a COPY/BASIS input file. (Refer to the COPY/BASIS Member File ID <i>n</i> field in the Library record.)
Reserved	CL8	Reserved for future use
Length of source record	HL2	The length of the actual source record following
Reserved	CL10	Reserved for future use
Source record	CL(<i>n</i>)	

COPY REPLACING record: X'0039'

One COPY REPLACING type record will be emitted each time a REPLACING action takes place. That is, whenever *operand-1* of the REPLACING phrase is matched with text in the copybook, a COPY REPLACING TEXT record will be written.

The following table shows the contents of the COPY REPLACING record.

Table 125. SYSADATA COPY REPLACING record

Field	Size	Description
Starting line number of replaced string	FL4	The listing line number of the start of the text that resulted from REPLACING
Starting column number of replaced string	FL4	The listing column number of the start of the text that resulted from REPLACING
Ending line number of replaced string	FL4	The listing line number of the end of the text that resulted from REPLACING
Ending column number of replaced string	FL4	The listing column number of the end of the text that resulted from REPLACING
Starting line number of original string	FL4	The source file line number of the start of the text that was changed by REPLACING
Starting column number of original string	FL4	The source file column number of the start of the text that was changed by REPLACING
Ending line number of original string	FL4	The source file line number of the end of the text that was changed by REPLACING
Ending column number of original string	FL4	The source file column number of the end of the text that was changed by REPLACING

Symbol record: X'0042'

The following table shows the contents of the symbol record.

Table 126. SYSADATA symbol record

Field	Size	Description
Symbol ID	FL4	Unique ID of symbol
Line number	FL4	The listing line number of the source record in which the symbol is defined or declared
Level	XL1	True level-number of symbol (or relative level-number of a data item within a structure). For COBOL, this can be in the range 01-49, 66 (for RENAMES items), 77, or 88 (for condition items).
Qualification indicator	XL1	<p>X'00' Unique name; no qualification needed.</p> <p>X'01' This data item needs qualification. The name is not unique within the program. This field applies only when this data item is <i>not</i> the level-01 name.</p>
Symbol type	XL1	<p>X'68' Class-name (Class-ID)</p> <p>X'58' Method-name</p> <p>X'40' Data-name</p> <p>X'20' Procedure-name</p> <p>X'10' Mnemonic-name</p> <p>X'08' Program-name</p> <p>X'81' Reserved</p> <p>The following ORed are into the above types, when applicable:</p> <p>X'04' External</p> <p>X'02' Global</p>

Table 126. SYSADATA symbol record (continued)

Field	Size	Description
Symbol attribute	XL1	<p>X'01' Numeric</p> <p>X'02' Elementary character of one of these classes:</p> <ul style="list-style-type: none"> • Alphabetic • Alphanumeric • DBCS • National <p>X'03' Group</p> <p>X'04' Pointer</p> <p>X'05' Index data item</p> <p>X'06' Index-name</p> <p>X'07' Condition</p> <p>X'0F' File</p> <p>X'10' Sort file</p> <p>X'17' Class-name (repository)</p> <p>X'18' Object reference</p> <p>X'19' Currency-sign symbol</p> <p>X'1A' XML schema name</p>

Table 126. SYSADATA symbol record (continued)

Field	Size	Description
Clauses	XL1	<p>Clauses specified in symbol definition.</p> <p>For symbols that have a symbol attribute of Numeric (X'01'), Elementary character (X'02'), Group (X'03'), Pointer (X'04'), Index data item (X'05'), or Object reference (X'18'):</p> <p>1... Value</p> <p>.1.. Indexed</p> <p>..1. Redefines</p> <p>...1 Renames</p> <p>.... 1... Occurs</p> <p>.... .1.. Has Occurs keys</p> <p>.... ..1. Occurs Depending On</p> <p>.... ...1 Occurs in parent</p> <p>For file types:</p> <p>1... Select</p> <p>.1.. Assign</p> <p>..1. Rerun</p> <p>...1 Same area</p> <p>.... 1... Same record area</p> <p>.... .1.. Recording mode</p> <p>.... ..1. Reserved</p> <p>.... ...1 Record</p>

Table 126. SYSADATA symbol record (continued)

Field	Size	Description
		For mnemonic-name symbols:
		01 CSP
		02 C01
		03 C02
		04 C03
		05 C04
		06 C05
		07 C06
		08 C07
		09 C08
		10 C09
		11 C10
		12 C11
		13 C12
		14 S01
		15 S02
		16 S03
		17 S04
		18 S05
		19 CONSOLE
		20 SYSIN SYSIPT
		22 SYSOUT SYSLST SYSLIST
		24 SYSPUNCH SYSPCH
		26 UPSI-0
		27 UPSI-1
		28 UPSI-2
		29 UPSI-3
		30 UPSI-4
		31 UPSI-5
		32 UPSI-6
		33 UPSI-7
		34 AFP-5A

Table 126. SYSADATA symbol record (continued)

Field	Size	Description
Data flags 1	XL1	<p>For file types, and for symbols that have a symbol attribute of Numeric (X'01'), Elementary character (X'02'), Group (X'03'), Pointer (X'04'), Index data item (X'05'), or Object reference (X'18'):</p> <p>1... Redefined</p> <p>.1.. Renamed</p> <p>..1. Synchronized</p> <p>...1 Implicitly redefined</p> <p>.... 1... Volatile</p> <p>.... .1.. Implicit redefines</p> <p>.... ..1. FILLER</p> <p>.... ...1 Level 77</p>

Table 126. SYSADATA symbol record (continued)

Field	Size	Description
Data flags 2	XL1	<p>For symbols that have a symbol attribute of Numeric (X'01'):</p> <p>1... Binary</p> <p>.1.. External floating point (of USAGE DISPLAY or USAGE NATIONAL)</p> <p>..1. Internal floating point</p> <p>...1 Packed</p> <p>.... 1... External decimal (of USAGE DISPLAY or USAGE NATIONAL)</p> <p>.... .1.. Scaled negative</p> <p>.... ..1. Numeric edited (of USAGE DISPLAY or USAGE NATIONAL)</p> <p>.... ...1 Reserved for future use</p> <p>For symbols that have a symbol attribute of Elementary character (X'02') or Group (X'03'):</p> <p>1... Alphabetic</p> <p>.1.. Alphanumeric</p> <p>..1. Alphanumeric edited</p> <p>...1 Group contains its own ODO object</p> <p>.... 1... DBCS item</p> <p>.... .1.. Group variable length</p> <p>.... ..1. EGCS item</p> <p>.... ...1 EGCS edited</p>

Table 126. SYSADATA symbol record (continued)

Field	Size	Description
		<p>For file types:</p> <p>1... Object of ODO in record</p> <p>.1.. Subject of ODO in record</p> <p>..1. Sequential access</p> <p>...1 Random access</p> <p>.... 1... Dynamic access</p> <p>.... .1.. Locate mode</p> <p>.... ..1. Record area</p> <p>.... ...1 Reserved for future use</p>
Data flags 3	XL1	<p>1... All records are the same length</p> <p>.1.. Fixed length</p> <p>..1. Variable length</p> <p>...1 Undefined</p> <p>.... 1... Spanned</p> <p>.... .1.. Blocked</p> <p>.... ..1. Apply write only</p> <p>.... ...1 Same sort merge area</p>

Table 126. SYSADATA symbol record (continued)

Field	Size	Description
File organization and attributes	XL1	<p>1... .. Physical sequential (on host, QSAM)</p> <p>.1.. .. ASCII</p> <p>..1. Standard label</p> <p>...1 User label</p> <p>.... 1... Sequential organization</p> <p>.... .1.. Indexed organization</p> <p>.... ..1. Relative organization</p> <p>.... ...1 Line sequential</p>
USAGE clause	FL1	<p>X'00' USAGE IS DISPLAY</p> <p>X'01' USAGE IS COMP-1</p> <p>X'02' USAGE IS COMP-2</p> <p>X'03' USAGE IS PACKED-DECIMAL or USAGE IS COMP-3</p> <p>X'04' USAGE IS BINARY, USAGE IS COMP, USAGE IS COMP-4, or USAGE IS COMP-5</p> <p>X'05' USAGE IS DISPLAY-1</p> <p>X'06' USAGE IS POINTER</p> <p>X'07' USAGE IS INDEX</p> <p>X'08' USAGE IS PROCEDURE-POINTER</p> <p>X'09' USAGE IS OBJECT-REFERENCE</p> <p>X'0A' FUNCTION-POINTER</p> <p>X'0B' NATIONAL</p>
Sign clause	FL1	<p>X'00' No SIGN clause</p> <p>X'01' SIGN IS LEADING</p> <p>X'02' SIGN IS LEADING SEPARATE CHARACTER</p> <p>X'03' SIGN IS TRAILING</p> <p>X'04' SIGN IS TRAILING SEPARATE CHARACTER</p>
Indicators	FL1	<p>X'01' Has JUSTIFIED clause. Right-justified attribute is in effect.</p> <p>X'02' Has BLANK WHEN ZERO clause.</p>

Table 126. SYSADATA symbol record (continued)

Field	Size	Description
Size	FL4	The size of this data item. The actual number of bytes this item occupies in storage. If a DBCS item, the number is in bytes, not characters. For variable-length items, this field will reflect the maximum size of storage reserved for this item by the compiler. Also known as the "Length attribute."
Precision	FL1	The precision of a fixed or float data item
Scale	FL1	The scale factor of a fixed data item. This is the number of digits to the right of the decimal point.
Storage type	FL1	<p>00 Not applicable</p> <p>01 Files</p> <p>02 Working-Storage</p> <p>03 Linkage Section</p> <p>05 Special registers</p> <p>07 Indexed by variable</p> <p>10 UPSI switch</p> <p>13 Variably located items</p> <p>14 External data</p> <p>15 Alphanumeric FUNC</p> <p>16 Alphanumeric EVAL</p> <p>17 Object data</p> <p>19 Local-Storage</p> <p>20 Factory data</p> <p>21 XML-TEXT and XML-NTEXT</p>
Date format	FL1	Reserved for future use
Data flags 4	XL1	<p>For symbols that have a symbol attribute of Numeric (X'01'):</p> <p>1... .. Numeric national</p> <p>For symbols that have a symbol attribute of Elementary character (X'02'):</p> <p>1... .. National</p> <p>.1... .. National edited</p> <p>For symbols that have a symbol attribute of Group (X'03'):</p> <p>1... .. Group-Usage National</p> <p>.1... .. Unbounded length group</p>

Table 126. SYSADATA symbol record (continued)

Field	Size	Description
Data flags 5	XL1	OCCURS flags: 1 UNBOUNDED
Base locator Cell	FL2	Base locator cell number
Symbol Identifier	FL4	Number identifying the symbol
Structure displacement	AL4	Offset of symbol within structure. This offset is set to 0 for variably located items.
Parent displacement	AL4	Byte offset from immediate parent of the item being defined.
Parent ID	FL4	The symbol ID of the immediate parent of the item being defined.
Redefined ID	FL4	The symbol ID of the data item that this item redefines, if applicable.
Start-renamed ID	FL4	If this item is a level-66 item, the symbol ID of the starting COBOL data item that this item renames. If not a level-66 item, this field is set to 0.
End-renamed ID	FL4	If this item is a level-66 item, the symbol ID of the ending COBOL data item that this item renames. If not a level-66 item, this field is set to 0.
Program-name symbol ID	FL4	ID of the program-name of the program or the class-name of the class where this symbol is defined.
OCCURS minimum	FL4	Minimum value for OCCURS
Paragraph ID		Proc-name ID for a paragraph-name
OCCURS maximum	FL4	Maximum value for OCCURS
Section ID		Proc-name ID for a section-name
Dimensions	FL4	Number of dimensions
Case bit vector	XL4	The case of the characters in the symbol name is represented with one bit per character. Each bit has the following meaning: 0 Uppercase 1 Lowercase Bit 0 represents the case of the first character, bit 1 represents the case of the second character, and so forth.
Reserved	CL8	Reserved for future use
Value pairs count	HL2	Count of value pairs
Symbol name length	HL2	Number of characters in the symbol name

Table 126. SYSADATA symbol record (continued)

Field	Size	Description
Picture data length for data-name or Assignment-name length for file-name	HL2	Number of characters in the picture data; zero if symbol has no associated PICTURE clause. (Length of the PICTURE field.) Length represents the field as it is found in the source input. This length does not represent the expanded field for PICTURE items that contain a replication factor. The maximum COBOL length for a PICTURE string is 50 bytes. Zero in this field indicates no PICTURE specified. Number of characters in the external file-name if this is a file-name. This is the DD name part of the assignment-name. Zero if file-name and ASSIGN USING specified.
Initial Value length for data-name External class-name length for CLASS-ID	HL2	Number of characters in the symbol value; zero if symbol has no initial value Number of characters in the external class-name for CLASS-ID
ODO symbol name ID for data-name ID of ASSIGN data-name if file-name	FL4	If data-name, ID of the ODO symbol name; zero if ODO not specified If file-name, Symbol-ID for ASSIGN USING data-name; zero if ASSIGN TO specified
Keys count	HL2	The number of keys defined
Index count	HL2	Count of Index symbol IDs; zero if none specified
Symbol name	CL(n)	
Picture data string for data-name or Assignment-name for file-name	CL(n)	The PICTURE character string <i>exactly</i> as the user types it in. The character string includes all symbols, parentheses, and replication factor. The external file-name if this is a file-name. This is the DD name part of the assignment-name.
Index ID list	(n)FL4	ID of each index symbol name
Keys	(n)XL8	This field contains data describing keys specified for an array. The following three fields are repeated as many times as specified in the 'Keys count' field.
...Key Sequence	FL1	Ascending or descending indicator. X'00' DESCENDING X'01' ASCENDING
...Filler	CL3	Reserved
...Key ID	FL4	The symbol ID of the data item that is the key field in the array
Initial Value data for data-name External class-name for CLASS-ID	CL(n)	This field contains the data specified in the INITIAL VALUE clause for this symbol. The following four subfields are repeated according to the count in the 'Value pairs count' field. The total length of the data in this field is contained in the 'Initial value length' field. The external class-name for CLASS-ID.
...1st value length	HL2	Length of first value

Table 126. SYSADATA symbol record (continued)

Field	Size	Description
...1st value data	CL(n)	1st value. This field contains the literal (or figurative constant) as it is specified in the VALUE clause in the source file. It includes any beginning and ending delimiters, embedded quotation marks, and SHIFT IN and SHIFT OUT characters. If the literal spans multiple lines, the lines are concatenated into one long string. If a figurative constant is specified, this field contains the actual reserved word, not the value associated with that word.
...2nd value length	HL2	Length of second value, zero if not a THRU value pair
...2nd value data	CL(n)	2nd value. This field contains the literal (or figurative constant) as it is specified in the VALUE clause in the source file. It includes any beginning and ending delimiters, embedded quotation marks, and SHIFT IN and SHIFT OUT characters. If the literal spans multiple lines, the lines are concatenated into one long string. If a figurative constant is specified, this field contains the actual reserved word, not the value associated with that word.

Symbol cross-reference record: X'0044'

The following table shows the contents of the symbol cross-reference record.

Table 127. SYSADATA symbol cross-reference record

Field	Size	Description
Symbol length	HL2	The length of the symbol
Statement definition	FL4	The statement number where the symbol is defined or declared For VERB XREF only: Verb count - total number of references to this verb.
Number of references ¹	HL2	The number of references in this record to the symbol following
Cross-reference type	XL1	X'01' Program X'02' Procedure X'03' Verb X'04' Symbol or data-name X'05' Method X'06' Class
Reserved	CL7	Reserved for future use
Symbol name	CL(n)	The symbol. Variable length.

Table 127. SYSADATA symbol cross-reference record (continued)

Field	Size	Description
...Reference flag	CL1	For symbol or data-name references: C' ' Blank means reference only C'M' Modification reference flag For Procedure type symbol references: C'A' ALTER (procedure-name) C'D' GO TO (procedure-name) DEPENDING ON C'E' End of range of (PERFORM) through (procedure-name) C'G' GO TO (procedure-name) C'P' PERFORM (procedure-name) C'T' (ALTER) TO PROCEED TO (procedure-name) C'U' Use for debugging (procedure-name)
...Statement number	XL4	The statement number on which the symbol or verb is referenced
1. The reference flag field and the statement number field occur as many times as the number of references field dictates. For example, if there is a value of 10 in the number of references field, there will be 10 occurrences of the reference flag and statement number pair for data-name, procedure, or program symbols, or 10 occurrences of the statement number for verbs. Where the number of references would exceed the record size for the SYSADATA file, the record is continued on the next record. The continuation flag is set in the common header section of the record.		

Nested program record: X'0046'

The following table shows the contents of the nested program record.

Table 128. SYSADATA nested program record

Field	Size	Description
Statement definition	FL4	The statement number where the symbol is defined or declared
Nesting level	XL1	Program nesting level
Program attributes	XL1	1... .. Initial .1... .. Common ..1. PROCEDURE DIVISION using ...1 1111 Reserved for future use
Reserved	XL1	Reserved for future use
Program-name length	XL1	Length of the following field
Program-name	CL(<i>n</i>)	The program-name

Library record: X'0060'

The following table shows the contents of the SYSADATA library record.

Table 129. SYSADATA library record

Field	Size	Description
Number of members ¹	HL2	Count of the number of COPY/INCLUDE code members described in this record
Library name length	HL2	The length of the library name
Library volume length	HL2	The length of the library volume ID
Concatenation number	XL2	Concatenation number of the library
Library ddname length	HL2	The length of the library ddname
Reserved	CL4	Reserved for future use
Library name	CL(<i>n</i>)	The name of the library from which the COPY/INCLUDE member was retrieved
Library volume	CL(<i>n</i>)	The volume identification of the volume where the library resides
Library ddname	CL(<i>n</i>)	The ddname (or equivalent) used for this library
...COPY/BASIS member file ID ²	HL2	The library file ID of the name following
...COPY/BASIS name length	HL2	The length of the name following
...COPY/BASIS name	CL(<i>n</i>)	The name of the COPY/BASIS member that has been used
<p>1. If 10 COPY members are retrieved from a library, the "Number of members" field will contain 10 and there will be 10 occurrences of the "COPY/BASIS member file ID" field, the "COPY/BASIS name length" field, and the "COPY/BASIS name" field.</p> <p>2. If COPY/BASIS members are retrieved from different libraries, a library record is written to the SYSADATA file for each unique library.</p>		

Statistics record: X'0090'

The following table shows the contents of the statistics record.

Table 130. SYSADATA statistics record

Field	Size	Description
Source records	FL4	The number of source records processed
DATA DIVISION statements	FL4	The number of DATA DIVISION statements processed
PROCEDURE DIVISION statements	FL4	The number of PROCEDURE DIVISION statements processed
Compilation number	HL2	Batch compilation number
Error severity	XL1	The highest error message severity

Table 130. SYSADATA statistics record (continued)

Field	Size	Description
Flags	XL1	1... .. End of Job indicator .1... .. Class definition indicator ..11 1111 Reserved for future use
EOJ severity	XL1	The maximum return code for the compile job
Program-name length	XL1	The length of the program-name
Program-name	CL(<i>n</i>)	Program-name

EVENTS record: X'0120'

Events records are included in the ADATA file to provide compatibility with previous levels of the compiler.

Events records are of the following types:

- Time stamp
- Processor
- File end
- Program
- File ID
- Error

Table 131. SYSADATA EVENTS TIMESTAMP record layout

Field	Size	Description
Header	CL12	Standard ADATA record header
Record length	HL2	Length of following EVENTS record data (excluding this halfword)
EVENTS record type TIMESTAMP record	CL12	C'TIMESTAMP'
Blank separator	CL1	
Revision level	XL1	
Blank separator	CL1	
Date	XL8	YYYYMMDD
Hour	XL2	HH
Minutes	XL2	MI
Seconds	XL2	SS

Table 132. SYSADATA EVENTS PROCESSOR record layout

Field	Size	Description
Header	CL12	Standard ADATA record header
Record length	HL2	Length of following EVENTS record data (excluding this halfword)

Table 132. SYSADATA EVENTS PROCESSOR record layout (continued)

Field	Size	Description
EVENTS record type PROCESSOR record	CL9	C'PROCESSOR'
Blank separator	CL1	
Revision level	XL1	
Blank separator	CL1	
Output file ID	XL1	
Blank separator	CL1	
Line-class indicator	XL1	

Table 133. SYSADATA EVENTS FILE END record layout

Field	Size	Description
Header	CL12	Standard ADATA record header
Record length	HL2	Length of following EVENTS record data (excluding this halfword)
EVENTS record type FILE END record	CL7	C'FILEEND'
Blank separator	CL1	
Revision level	XL1	
Blank separator	CL1	
Input file ID	XL1	
Blank separator	CL1	
Expansion indicator	XL1	

Table 134. SYSADATA EVENTS PROGRAM record layout

Field	Size	Description
Header	CL12	Standard ADATA record header
Record length	HL2	Length of following EVENTS record data (excluding this halfword)
EVENTS record type PROGRAM record	CL7	C'PROGRAM'
Blank separator	CL1	
Revision level	XL1	
Blank separator	CL1	
Output file ID	XL1	
Blank separator	CL1	
Program input record number	XL1	

Table 135. SYSADATA EVENTS FILE ID record layout

Field	Size	Description
Header	CL12	Standard ADATA record header

Table 135. SYSADATA EVENTS FILE ID record layout (continued)

Field	Size	Description
Record length	HL2	Length of following EVENTS record data (excluding this halfword)
EVENTS record type FILE ID record	CL7	C'FILEID'
Blank separator	CL1	
Revision level	XL1	
Blank separator	CL1	
Input source file ID	XL1	File ID of source file
Blank separator	CL1	
Reference indicator	XL1	
Blank separator	CL1	
Source file name length	H2	
Blank separator	CL1	
Source file name	CL(n)	

Table 136. SYSADATA EVENTS ERROR record layout

Field	Size	Description
Header	CL12	Standard ADATA record header
Record length	HL2	Length of following EVENTS record data (excluding this halfword)
EVENTS record type ERROR record	CL5	C'ERROR'
Blank separator	CL1	
Revision level	XL1	
Blank separator	CL1	
Input source file ID	XL1	File ID of source file
Blank separator	CL1	
Annot class	XL1	Annot-class message placement
Blank separator	CL1	
Error input record number	XL10	
Blank separator	CL1	
Error start line number	XL10	
Blank separator	CL1	
Error token start number	XL1	Column number of error token start
Blank separator	CL1	
Error end line number	XL10	
Blank separator	CL1	

Table 136. SYSADATA EVENTS ERROR record layout (continued)

Field	Size	Description
Error token end number	XL1	Column number of error token end
Blank separator	CL1	
Error message ID number	XL9	
Blank separator	CL1	
Error message severity code	XL1	
Blank separator	CL1	
Error message severity level number	XL2	
Blank separator	CL1	
Error message length	HL3	
Blank separator	CL1	
Error message text	CL(n)	

Appendix G. Using sample programs

The sample programs, which are included on your product tape, demonstrate many language elements and concepts of COBOL.

This information contains the following items:

- Overview of the programs, including program charts for two of the samples
- Format and sample of the input data
- Sample of reports produced
- Information about how to run the programs
- List of the language elements and concepts that are illustrated

Pseudocode and other comments about the programs are included in the program prolog, which you can obtain in a program listing.

There are three sample programs:

- IGYTCARA is an example of using QSAM files and VSAM indexed files, and shows how to use many COBOL intrinsic functions.
- IGYTCARB is an example of using IBM Interactive System Product Facility (ISPF).
- IGYTSALE is an example of using several of the features of the Language Environment callable services.

RELATED CONCEPTS

“IGYTCARA: batch application”

“IGYTCARB: interactive program” on page 809

“IGYTSALE: nested program application” on page 812

IGYTCARA: batch application

A company that has several local offices wants to establish employee carpools. Application IGYTCARA validates the transaction-file entries (QSAM sequential file processing) and updates a master file (VSAM indexed file processing).

This batch application does two tasks:

- Produces reports of employees who can share rides from the same home location to the same work location
- Updates the carpool data:
 - Adds data for new employees
 - Changes information for participating employees
 - Deletes employee records
 - Lists update requests that are not valid

The following diagram shows the parts of the application and how they are organized:

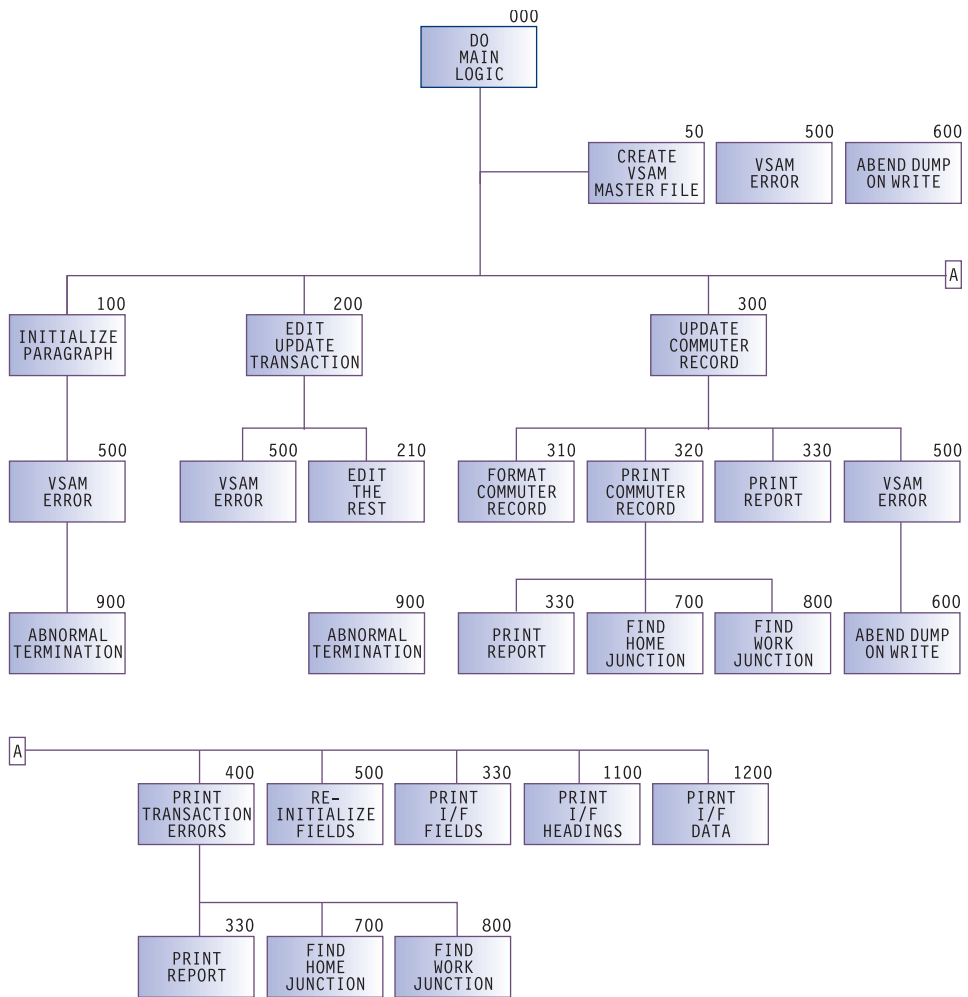

RELATED TASKS

“Preparing to run IGYTCARA” on page 808

RELATED REFERENCES

“Input data for IGYTCARA”

“Report produced by IGYTCARA” on page 807

“Language elements and concepts that are illustrated” on page 819

Input data for IGYTCARA

As input to the program, the company collected information from interested employees, coded the information, and produced an input file. Here is an example of the format of the input file (spaces between fields are left out, as they would be in your input file) with an explanation of each item.

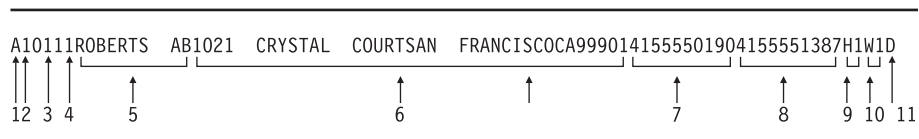

1. Transaction code
2. Shift
3. Home code

4. Work code
5. Commuter name
6. Home address
7. Home phone
8. Work phone
9. Home location code
10. Work location code
11. Driving status code

This sample below shows a section of the input file:

```

A10111ROBERTS AB1021 CRYSTAL COURTSAN FRANCISCOCA9990141555501904155551387H1W1D
A20212KAHN DE789 EMILY LANE SAN FRANCISCOCA9992141555518904155552589H2W2D
P48899 99ASDFG0005557890123ASDFGHJ T
R10111ROBERTS AB1221 CRYSTAL COURTSAN FRANCISCOCA9990141555501904155551387H1W1D
A20212KAHN DE789 EMILY LANE SAN FRANCISCOCA9992141555518904155552589H2W2D
D20212KAHN DE
D20212KAHN DE
A20212KAHN DE789 EMILY LANE SAN FRANCISCOCA9992141555518904155552589H2W2D
A10111BONNICK FD1025 FIFTH AVENUE SAN FRANCISCOCA9990541555595904155557895H8W3
A10111PETERSON SW435 THIRD AVENUE SAN FRANCISCOCA9990541555546904155553717H3W4
. . .

```

Report produced by IGYTCARA

The following sample shows the first page of the output report produced by IGYTCARA. Your actual output might vary slightly in appearance, depending on your system.

1-REPORT #: IGYTCAR1 COMMUTER FILE UPDATE LIST PAGE #: 1									
-PROGRAM #: IGYTCAR1 RUN TIME: 01:40 RUN DATE: 11/24/2003									
TRANS CODE	RE-CORD TYPE	SHIFT HOME CODE WORK CODE	COMMUTER NAME	HOME ADDRESS	HOME PHONE WORK PHONE	HOME LOCATION WORK LOCATION	JUNCTION JUNCTION	STA-TUS CODE	TRANS. ERROR
A	NEW	1 01 11	ROBERTS	AB 1021 CRYSTAL COURT SAN FRANCISCO CA 99901	(415) 555-0190 (415) 555-1387	RODNEY/CRYSTAL BAYFAIR PLAZA		D	
A	NEW	2 02 12	KAHN	DE 789 EMILY LANE SAN FRANCISCO CA 99921	(415) 555-1890 (415) 555-2589	COYOTE 14TH STREET/166TH AVENUE		D	
P		4 88 99			(000) 555-7890 99 ASDFG (123) ASD-FGHJ	HOME CODE ' ' NOT FOUND. WORK CODE ' ' NOT FOUND.		T	TRANSACTION CODE SHIFT CODE HOME LOC. CODE WORK LOC. CODE LAST NAME INITIALS ADDRESS CITY STATE CODE ZIPCODE HOME PHONE WORK PHONE HOME JUNCTION WORK JUNCTION DRIVING STATUS
R	OLD	1 01 11	ROBERTS	AB 1021 CRYSTAL COURT SAN FRANCISCO CA 99901	(415) 555-0190 (415) 555-1387	RODNEY/CRYSTAL BAYFAIR PLAZA		D	
	NEW	1 01 11	ROBERTS	AB 1221 CRYSTAL COURT SAN FRANCISCO CA 99901	(415) 555-0190 (415) 555-1387	RODNEY/CRYSTAL BAYFAIR PLAZA		D	
A		2 02 12	KAHN	DE 789 EMILY LANE SAN FRANCISCO CA 99921	(415) 555-1890 (415) 555-2589	COYOTE 14TH STREET/166TH AVENUE		D	DUPLICATE REC.
D	OLD	2 02 12	KAHN	DE 789 EMILY LANE SAN FRANCISCO CA 99921	(415) 555-1890 (415) 555-2589	COYOTE 14TH STREET/166TH AVENUE		D	
D		2 02 12	KAHN	DE					REC. NOT FOUND
A	NEW	2 02 12	KAHN	DE 789 EMILY LANE SAN FRANCISCO CA 99921	(415) 555-1890 (415) 555-2589	COYOTE 14TH STREET/166TH AVENUE		D	
A	NEW	1 01 11	BONNICK	FD 1025 FIFTH AVENUE SAN FRANCISCO CA 99905	(415) 555-9590 (415) 555-7895	RODNEY 17TH FREEWAY SAN LEANDRO			
A	NEW	1 01 11	PETERSON	SW 435 THIRD AVENUE	(415) 555-4690	RODNEY/THIRD AVENUE			

Preparing to run IGYTCARA

All files required by the IGYTCARA program (IGYTCARA, IGYTCODE, and IGYTRANX) are supplied on the product installation tape. These files are located in the IGY.V5R1M0.SIGYSAMP data set.

Data-set and procedure names might be changed at installation time. Check with your system programmer to verify these names.

Do not change these options on the CBL statement in the source file for IGYTCARA:

- NOADV
- NODYNAM
- NONAME
- NONUMBER
- QUOTE
- SEQUENCE

With these options in effect, the program will not cause any diagnostic messages to be issued. You can use the sequence number string in the source file to search for the language elements used.

RELATED CONCEPTS

"IGYTCARA: batch application" on page 805

RELATED TASKS

"Running IGYTCARA"

RELATED REFERENCES

"Input data for IGYTCARA" on page 806

"Report produced by IGYTCARA" on page 807

"Language elements and concepts that are illustrated" on page 819

Running IGYTCARA

The following procedure compiles, link-edits, and runs the IGYTCARA program. If you want only to compile or only to compile and link-edit the program, you must change the IGYWCLG cataloged procedure.

To run IGYTCARA under z/OS, use JCL to define a VSAM cluster and compile the program. Insert the information specific to your system and installation (accounting information, volume serial number, unit name, cluster prefix) in the fields that are shown in lowercase letters. These examples use the name IGYTCAR.MASTFILE; you can use another name if you want to.

1. Use this JCL to create the required VSAM cluster:

```
//CREATE JOB (acct-info), 'IGYTCAR CREATE VSAM',MSGLEVEL=(1,1),
// TIME=(0,29)
//CREATE EXEC PGM=IDCAMS
//VOL1 DD VOL=ser=your-volume-serial,UNIT=your-unit,DISP=SHR
//SYSPRINT DD SYSOUT=A
//SYSIN DD *
DELETE your-prefix.IGYTCAR.MASTFILE -
FILE(VOL1) -
PURGE
DEFINE CLUSTER -
(NAME(your-prefix.IGYTCAR.MASTFILE) -
VOLUME(your-volume-serial) -
FILE(VOL1) -
```



```

INDEXED -
RECSZ(80 80) -
KEYS(16 0) -
CYLINDERS(2)
/*

```

To remove any existing cluster, a DELETE is issued before the VSAM cluster is created.

2. Use the following JCL to compile, link-edit, and run the IGYTCARA program:

```

//IGYTCARA JOB (acct-info), 'IGYTCAR',MSGLEVEL=(1,1),TIME=(0,29)
//TEST EXEC IGYWCLG
//COBOL.SYSLIB DD DSN=IGY.V5R1M0.SIGYSAMP,DISP=SHR
//COBOL.SYSIN DD DSN=IGY.V5R1M0.SIGYSAMP(IGYTCARA),DISP=SHR
//GO.SYSOUT DD SYSOUT=A
//GO.COMMUTR DD DSN=your-prefix.IGYTCAR.MASTFILE,DISP=SHR
//GO.LOCCODE DD DSN=IGY.V5R1M0.SIGYSAMP(IGYTCODE),DISP=SHR
//GO.UPDTRANS DD DSN=IGY.V5R1M0.SIGYSAMP(IGYTRANX),DISP=SHR
//GO.UPDPRINT DD SYSOUT=A,DCB=BLKSIZE=133
//

```

RELATED TASKS

Chapter 10, "Processing VSAM files," on page 185

RELATED REFERENCES

"Compile, link-edit, and run procedure (IGYWCLG)" on page 259

IGYTCARB: interactive program

IGYTCARB contains an interactive program for entering carpool data by using IBM Interactive System Productivity Facility (ISPF) to invoke Dialog Manager and Enterprise COBOL. IGYTCARB creates a file that can be used as input for a carpool listing or matching program such as IGYTCARA.

The input data for IGYTCARB is the same as that for IGYTCARA. IGYTCARB lets you append to the information in your input file by using an ISPF panel. An example of the panel used by IGYTCARB is shown below:

```

----- CARPOOL DATA ENTRY -----
                New Data Entry
Type =====> -                A, R, or D   Previous Entry
Shift =====> -                1, 2, or 3   1
Home Code ==> --                2 Chars     01
Work Code ==> --                2 Chars     11
Name =====> -----            9 Chars     POPOWICH
Initials ==> --                2 Chars     AD
Address =====> -----          18 Chars    134 SIXTH AVENUE
City =====> -----            13 Chars    SAN FRANCISCO
State =====> --                2 Chars     CA
Zip Code ==> -----              5 Chars     99903
Home Phone => -----            10 Chars    4155553390
Work Phone => -----            10 Chars    4155557855
Home Jnc code > --                2 Chars     H3
Work Jnc Code > --                2 Chars     W7
Commuter Stat > -                D, R or blank

```

RELATED TASKS

"Preparing to run IGYTCARB" on page 810

Preparing to run IGYTCARB

Run the IGYTCARB program under Interactive System Productivity Facility (ISPF). All files required by IGYTCARB (IGYTCARB, IGYTRANB, and IGYTPNL) are supplied on the product installation tape in the IGY.V5R1M0.SIGYSAMP data set.

Data-set names and procedure-names might be changed at installation time. Check with your system programmer to verify the names.

Do not change the following options in the CBL statement in the source file for IGYTCARB:

- NONUMBER
- QUOTE
- SEQUENCE

With these options in effect, the program will not cause any diagnostic messages to be issued. You can use the sequence number string in the source file to search for language elements.

RELATED CONCEPTS

“IGYTCARB: interactive program” on page 809

RELATED TASKS

“Running IGYTCARB”

RELATED REFERENCES

“Language elements and concepts that are illustrated” on page 819

Running IGYTCARB

The following procedure compiles, link-edits, and runs the IGYTCARB program. If you want only to compile or only to compile and link-edit the program, you must change the procedure.

To run IGYTCARB under z/OS, do the following steps:

1. Using the ISPF editor, change the ISPF/PDF Primary Option Panel (ISR@PRIM) or some other panel to include the IGYTCARB invocation. Panel ISR@PRIM is in your site's PDF panel data set (normally ISRPLIB).

The following example shows an ISR@PRIM panel modified, in two identified locations, to include the IGYTCARB invocation. If you add or change an option in the upper portion of the panel definition, you must also add or change the corresponding line on the lower portion of the panel.

```
%----- ISPF/PDF PRIMARY OPTION PANEL -----+
%OPTION ==>_ZCMD
%
% 0 +ISPF PARMS - Specify terminal and user parameters +USERID - &ZUSER
% 1 +BROWSE - Display source data or output listings +TIME - &ZTIME
% 2 +EDIT - Create or change source data +PF KEYS - &ZKEYS
% 3 +UTILITIES - Perform utility functions
% 4 +FOREGROUND - Invoke language processors in foreground
% 5 +BATCH - Submit to batch for language processing
% 6 +COMMAND - Enter TSO or Workstation commands
% 7 +DIALOG TEST - Perform dialog testing
% 8 +LM UTILITIES- Perform library management utility functions
% C +IGYTCARB - Run IGYTCARB UPDATE TRANSACTION PROGRAM (1)
% T +TUTORIAL - Display information about ISPF/PDF
% X +EXIT - Terminate using console, log, and list defaults
%
%
```

+Enter%END+command to terminate ISPF.

```
%
)INIT
  .HELP = ISR00003
  &ZPRIM = YES          /* ALWAYS A PRIMARY OPTION MENU */
  &ZHTOP = ISR00003     /* TUTORIAL TABLE OF CONTENTS */
  &ZHINDEX = ISR91000  /* TUTORIAL INDEX - 1ST PAGE */
  VPUT (ZHTOP,ZHINDEX) PROFILE
)PROC
  &Z1 = TRUNC(&ZCMD,1)
  IF (&Z1 &notsym.= '.' )
    &ZSEL = TRANS( TRUNC (&ZCMD, '.')
      0, 'PANEL(ISPOPTA)'
      1, 'PGM(ISRBRO) PARM(ISRBRO01)'
      2, 'PGM(ISREDIT) PARM(P,ISREDM01)'
      3, 'PANEL(ISRUTIL)'
      4, 'PANEL(ISRFPA)'
      5, 'PGM(ISRJB1) PARM(ISRJPA) NOCHECK'
      6, 'PGM(ISRPCC)'
      7, 'PGM(ISRYXDR) NOCHECK'
      8, 'PANEL(ISRLPRIM)'
      C, 'PGM(IGYTCARB)'
      T, 'PGM(ISPTUTOR) PARM(ISR00000)'
      , , ,
      X, 'EXIT'
      *, '?' )
    &ZTRAIL = .TRAIL
  IF (&Z1 = '.' ) .msg = ISPD141
)END
```

As indicated by (1) in this example, you add IGYTCARB to the upper portion of the panel by entering:

```
% C +IGYTCARB - Run IGYTCARB UPDATE TRANSACTION PROGRAM
```

You add the corresponding line on the lower portion of the panel, indicated by (2), by entering:

```
C, 'PGM(IGYTCARB)'
```

- Place ISR@PRIM (or your other modified panel) and IGYTPNL in a library and make this library the first library in the ISPLLIB concatenation.
- Comment sequence line IB2200 and uncomment sequence line IB2210 in IGYTCARB. (The OPEN EXTEND verb is supported under z/OS.)
- Compile and link-edit IGYTCARB and place the resulting program object in your LOADLIB.
- Allocate ISPLLIB by using the following command:
ALLOCATE FILE(ISPLLIB) DATASET(DSN1, SYS1.COBLIB, DSN2) SHR REUSE
Here *DSN1* is the library name of the LOADLIB from step 4. *DSN2* is your installed ISPLLIB.
- Allocate the input and output data sets by using the following command:
ALLOCATE FILE(UPDTRANS) DA('IGY.V5R1M0.SIGYSAMP(IGYTRANB)') SHR REUSE
- Allocate ISPLLIB by using the following command:
ALLOCATE FILE(ISPLLIB) DATASET(DSN3, DSN4) SHR REUSE
Here *DSN3* is the library containing the modified panels. *DSN4* is the ISPF panel library.
- Invoke IGYTCARB by using your modified panel.

RELATED REFERENCES

ISPF Dialog Developer's Guide and Reference

IGYTSALE: nested program application

Application IGYTSALE tracks product sales and sales commissions for a sporting-goods distributor.

This nested program application does the following tasks:

1. Keeps a record of the product line, customers, and number of salespeople. This data is stored in a file called IGYTABLE.
2. Maintains a file that records valid transactions and transaction errors. All transactions that are not valid are flagged, and the results are printed in a report. Transactions to be processed are in a file called IGYTRANA.
3. Processes transactions and report sales by location.
4. Records an individual's sales performance and commission, and prints the results in a report.
5. Reports the sale and shipment dates in local time and UTC (Universal Time Coordinate), and calculates the response time.

The following diagram shows the parts of the application as a hierarchy:

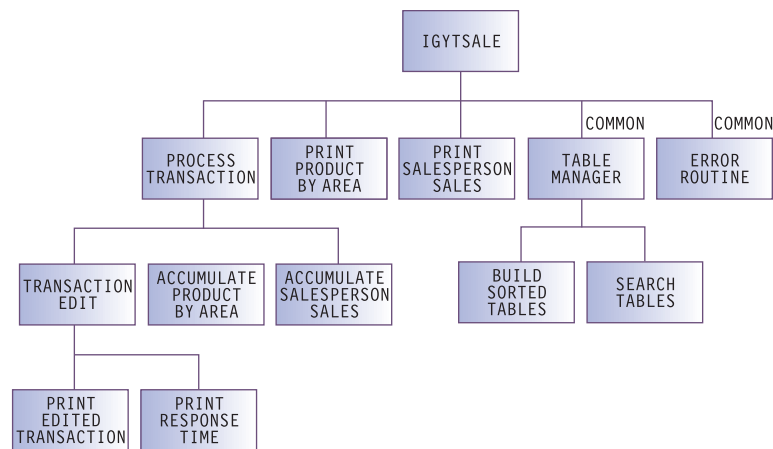

The following diagram shows how the parts are nested:

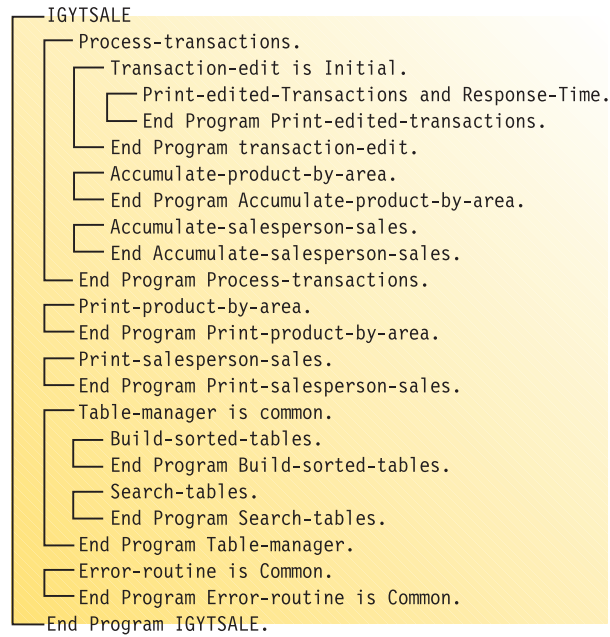

RELATED TASKS

“Preparing to run IGYTSALE” on page 818

RELATED REFERENCES

“Input data for IGYTSALE”

“Reports produced by IGYTSALE” on page 815

“Language elements and concepts that are illustrated” on page 819

Input data for IGYTSALE

As input to our program, the distributor collected information about its customers, salespeople, and products, coded the information, and produced an input file.

This input file, called IGYTABLE, is loaded into three separate tables for use during transaction processing. The format of the file is as follows, with an explanation of the items below:

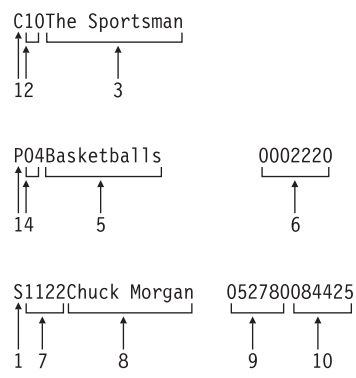

1. Record type
2. Customer code
3. Customer name
4. Product code

5. Product description
6. Product unit price
7. Salesperson number
8. Salesperson name
9. Date of hire
10. Commission rate

The value of field 1 (C, P, or S) determines the format of the input record. The following sample shows a section of IGYTABLE:

```

S1111Edyth Phillips 062484042327
S1122Chuck Morgan 052780084425
S1133Art Tung 022882061728
S1144Billy Jim Bob 010272121150
S1155Chris Preston 122083053377
S1166Al Willie Roz 111276100000
P01Footballs 0000620
P02Football Equipment 0032080
P03Football Uniform 0004910
P04Basketballs 0002220
P05Basketball Rim/Board0008830
P06Basketball Uniform 0004220
C01L. A. Sports
C02Gear Up
C03Play Outdoors
C04Sports 4 You
C05Sports R US
C06Stay Active
C07Sport Shop
C08Stay Sporty
C09Hot Sports
C10The Sportsman
C11Playing Ball
C12Sports Play
. . .

```

In addition, the distributor collected information about sales transactions. Each transaction represents an individual salesperson's sales to a particular customer. The customer can purchase from one to five items during each transaction. The transaction information is coded and put into an input file, called IGYTRANA. The format of this file is as follows, with an explanation of the items below:

```

B11123919901110123314SAN DIEGO 11660919901114235505260200270500110522250100140010
  ↑   ↑   ↑   ↑   ↑   ↑   ↑   ↑   ↑   ↑   ↑   ↑   ↑   ↑   ↑   ↑   ↑   ↑   ↑   ↑
  1   2   3   4   5   6   7   8   9   8   9   8   9   8   9   8   9   8   9

```

1. Sales order number
2. Invoiced items (number of different items ordered)
3. Date of sale (year month day hour minutes seconds)
4. Sales area
5. Salesperson number
6. Customer code
7. Date of shipment (year month day hour minutes seconds)
8. Product code
9. Quantity sold

Fields 8 and 9 occur one to eight times depending on the number of different items ordered (field 2). The following sample shows a section of IGYTRANA:

```
A00001119900227010101CNTRL VALLEY11442019900228259999
A00004119900310100530CNTRL VALLEY11441019900403150099
A00005119900418222409CNTRL VALLEY11441219900419059900
A00006119900523151010CNTRL VALLEY11442019900623250004
      419990324591515SAN DIEGO      11615      60200132200110522045100
B11114419901111003301SAN DIEGO      11661519901114260200132200110522041100
A00007119901115003205CNTRL VALLEY11332019901117120023
C00125419900118101527SF BAY AREA 11331519900120160200112200250522145111
B11116419901201132013SF BAY AREA 11331519901203060200102200110522045102
B11117319901201070833SAN Diego      11656619901203330200132200120522041100
B11118419901221191544SAN DIEGO      11661419901223160200142200130522040300
B11119419901210211544SAN DIEGO      11221219901214060200152200160522050500
B11120419901212000816SAN DIEGO      11220419901213150200052200160522040100
B11121419901201131544SAN DIEGO      11330219901203120200112200140522250100
B11122419901112073312SAN DIEGO      11221019901113100200162200260522250100
B11123919901110123314SAN DIEGO      11660919901114260200270500110522250100140010
B11124219901313510000SAN DIEGO      116611      1 0200042200120a22141100
B11125419901215012510SAN DIEGO      11661519901216110200162200130522141111
B11126119901111000034SAN DIEGO      11331619901113260022
B11127119901110154100SAN DIEGO      11221219901113122000
B11128419901110175001SAN DIEGO      11661519901113260200132200160521041104
. . .
```

Reports produced by IGYTSALE

The figures referenced below are samples of IGYTSALE output.

The program records the following data in reports:

- Transaction errors
- Sales by product and area
- Individual sales performance and commissions
- Response time between the sale date and the date the sold products are shipped

Your output might vary slightly in appearance, depending on your system.

“Example: IGYTSALE transaction errors”

“Example: IGYTSALE sales analysis by product by area” on page 816

“Example: IGYTSALE sales and commissions” on page 817

“Example: IGYTSALE response time from sale to ship” on page 817

Example: IGYTSALE transaction errors

The following sample of IGYTSALE output shows transaction errors in the last column.

```
Day of Report: Tuesday          C O B O L   S P O R T S          11/24/2003   03:12   Page: 1
                                Invalid Edited Transactions
Sales  Inv.  Sales  Sales  Sales  Cust.  Product And Quantity Sold  Ship
Order  Items Time Stamp  Area  Pers  Code                                     Date Stamp
-----
      4 19990324591515 SAN DIEGO      116      15 60200132200110522045100
                                                Error Descriptions
                                                -Sales order number is missing
                                                -Date of sale time stamp is invalid
                                                -Salesperson number not numeric
                                                -Product code not in product-table
                                                -Date of ship time stamp is invalid
B11117 3 19901201070833 SAN Diego      1165      66 33020o132200120522041100 19901203 Error Descriptions
                                                -Sales area not in area-table
                                                -Salesperson not in sales-per-table
                                                -Customer code not in customer-table
                                                -Product code not in product-table
                                                -Quantity sold not numeric
B11123 9 19901110123314 SAN DIEGO      1166      09 260200270500110522250100140010 19901114 Error Descriptions
                                                -Invoiced items is invalid
                                                -Product and quantity not checked
                                                -Date of ship time stamp is invalid
B11124 2 19901313510000 SAN DIEGO      1166      11 1 0200042200120a22141100
                                                Error Descriptions
                                                -Date of sale time stamp is invalid
                                                -Product code is invalid
                                                -Date of ship time stamp is invalid
      133      81119110000 LOS ANGELES 1166      10 040112110210160321251104
                                                Error Descriptions
```

C11133 4 1990111944 1166 10 040112110210160321251104
 C11138 4 19901117091530 LOS ANGELES 1155 113200102010260321250004
 000009 9 19901201222222 CNTRL COAST 115 19 141 1131221

-Sales order number is invalid
 -Invoiced items is invalid
 -Date of sale time stamp is invalid
 -Product and quantity not checked
 -Date of ship time stamp is invalid
 Error Descriptions
 -Date of sale time stamp is invalid
 -Sales area is missing
 -Date of ship time stamp is invalid
 19901119 Error Descriptions
 -Customer code is invalid
 19901202 Error Descriptions
 -Invoiced items is invalid

Example: IGYTSALE sales analysis by product by area

The following sample of IGYTSALE output shows sales by product and area.

Day of Report: Tuesday C O B O L S P O R T S 11/24/2003 03:12 Page: 1
 Sales Analysis By Product By Area

Product Codes	Areas of Sale						Product Totals
	CNTRL COAST	CNTRL VALLEY	LOS ANGELES	NORTH COAST	SAN DIEGO	SF BAY AREA	
Product Number 04 Basketballs							
Units Sold			433		2604	5102	8139
Unit Price			22.20		22.20	22.20	
Amount of Sale			\$9,612.60		\$57,808.80	\$113,264.40	\$180,685.80
Product Number 05 Basketball Rim/Board							
Units Sold		9900	2120	11	2700		14731
Unit Price		88.30	88.30	88.30	88.30		
Amount of Sale		\$874,170.00	\$187,196.00	\$971.30	\$238,410.00		\$1,300,747.30
Product Number 06 Basketball Uniform							
Units Sold			990		200	200	1390
Unit Price			42.20		42.20	42.20	
Amount of Sale			\$41,778.00		\$8,440.00	\$8,440.00	\$58,658.00
Product Number 10 Baseball Cage							
Units Sold	45		3450	16	200	3320	7031
Unit Price	890.00		890.00	890.00	890.00	890.00	
Amount of Sale	\$40,050.00		\$3,070,500.00	\$14,240.00	\$178,000.00	\$2,954,800.00	\$6,257,590.00
Product Number 11 Baseball Uniform							
Units Sold	10003		3578		2922	2746	19249
Unit Price	45.70		45.70		45.70	45.70	
Amount of Sale	\$457,137.10		\$163,514.60		\$133,535.40	\$125,492.20	\$879,679.30
Product Number 12 Softballs							
Units Sold	10	137	2564	13	2200	22	4946
Unit Price	1.40	1.40	1.40	1.40	1.40	1.40	
Amount of Sale	\$14.00	\$191.80	\$3,589.60	\$18.20	\$3,080.00	\$30.80	\$6,924.40
Product Number 13 Softball Bats							
Units Sold	3227		3300	1998	5444	99	14068
Unit Price	12.60		12.60	12.60	12.60	12.60	
Amount of Sale	\$40,660.20		\$41,580.00	\$25,174.80	\$68,594.40	\$1,247.40	\$177,256.80
Product Number 14 Softball Gloves							
Units Sold	1155		136	3119	3833	5152	13395
Unit Price	12.00		12.00	12.00	12.00	12.00	
Amount of Sale	\$13,860.00		\$1,632.00	\$37,428.00	\$45,996.00	\$61,824.00	\$160,740.00
Product Number 15 Softball Cage							
Units Sold	997	99	2000		2400		5496
Unit Price	890.00	890.00	890.00		890.00		
Amount of Sale	\$887,330.00	\$88,110.00	\$1,780,000.00		\$2,136,000.00		\$4,891,440.00
Product Number 16 Softball Uniform							
Units Sold	44		465	16	6165	200	6890
Unit Price	45.70		45.70	45.70	45.70	45.70	
Amount of Sale	\$2,010.80		\$21,250.50	\$731.20	\$281,740.50	\$9,140.00	\$314,873.00
Product Number 25 RacketBalls							
Units Sold	1001	10003	1108	8989	200	522	21823
Unit Price	0.60	0.60	0.60	0.60	0.60	0.60	
Amount of Sale	\$600.60	\$6,001.80	\$664.80	\$5,393.40	\$120.00	\$313.20	\$13,093.80
Product Number 26 Racketball Rackets							
Units Sold	21		862	194	944	31	2052
Unit Price	12.70		12.70	12.70	12.70	12.70	
Amount of Sale	\$266.70		\$10,947.40	\$2,463.80	\$11,988.80	\$393.70	\$26,060.40
Total Units Sold	16503	20139	20016	15346	29812	17394 *	119210 *
Total Sales	\$1,441,929.40	\$968,473.60	\$5,290,487.50	\$128,198.70	\$3,163,713.90	\$3,274,945.70 *	\$14,267,748.80 *

Example: IGYTSALE sales and commissions

The following sample of IGYTSALE output shows sales performance and commissions by salesperson.

Day of Report: Tuesday		C O B O L		S P O R T S		11/24/2003	03:12	Page: 1
				Sales and Commission Report				
Salesperson: Billy Jim Bob								
Customers:	Number of Orders	Products Ordered	Total for Order	Discount (if any)	Discount Amount	Commission Earned		
-----	-----	-----	-----	-----	-----	-----		
Sports Stop	3	10117	\$6,161.40	2.25%	\$138.63	\$746.45		
The Sportsman	1	99	\$88,110.00	5.06%	\$4,458.36	\$10,674.52		
Sports Play	1	9900	\$874,170.00	7.59%	\$66,349.50	\$105,905.69		
Totals:	5	20116	\$968,441.40		\$70,946.49	\$117,326.66		
Salesperson: Willie Al Roz								
Customers:	Number of Orders	Products Ordered	Total for Order	Discount (if any)	Discount Amount	Commission Earned		
-----	-----	-----	-----	-----	-----	-----		
Winners Club	4	13998	\$1,572,775.90	7.59%	\$119,373.69	\$157,277.59		
Winning Sports	1	3222	\$48,777.20	3.38%	\$1,648.66	\$4,877.72		
The Sportsman	1	1747	\$27,415.50	3.38%	\$926.64	\$2,741.55		
Play Outdoors	1	2510	\$18,579.60	3.38%	\$627.99	\$1,857.96		
Totals:	7	21477	\$1,667,548.20		\$122,576.98	\$166,754.82		
Salesperson: Art Tung								
Customers:	Number of Orders	Products Ordered	Total for Order	Discount (if any)	Discount Amount	Commission Earned		
-----	-----	-----	-----	-----	-----	-----		
Sports Stop	1	23	\$32.20	2.25%	\$7.72	\$1.98		
Winners Club	2	16057	\$2,274,885.00	7.59%	\$172,663.77	\$140,424.10		
Gear Up	1	3022	\$107,144.00	7.59%	\$8,132.22	\$6,613.78		
Sports Club	1	22	\$279.40	2.25%	\$6.28	\$17.24		
Sports Fans Shop	1	1044	\$20,447.30	3.38%	\$691.11	\$1,262.17		
L. A. Sports	1	1163	\$979,198.10	7.59%	\$74,321.13	\$60,443.94		
Totals:	7	21331	\$3,381,986.00		\$255,815.23	\$208,763.21		
Salesperson: Chuck Morgan								
Customers:	Number of Orders	Products Ordered	Total for Order	Discount (if any)	Discount Amount	Commission Earned		
-----	-----	-----	-----	-----	-----	-----		
Sports Play	3	7422	\$3,817,245.40	7.59%	\$289,728.92	\$322,270.94		
Sports 4 You	1	3022	\$398,335.40	7.59%	\$30,233.65	\$33,629.46		
The Sportsman	1	3022	\$285,229.40	7.59%	\$21,648.91	\$24,080.49		
Sports 4 Winners	1	1100	\$68,509.40	5.06%	\$3,466.57	\$5,783.90		
Sports Club	1	12027	\$1,324,256.10	7.59%	\$100,511.03	\$111,800.32		
Totals:	7	26593	\$5,893,575.70		\$445,589.08	\$497,565.11		
Salesperson: Chris Preston								
Customers:	Number of Orders	Products Ordered	Total for Order	Discount (if any)	Discount Amount	Commission Earned		
-----	-----	-----	-----	-----	-----	-----		
Playing Ball	1	5535	\$1,939,219.10	7.59%	\$147,186.72	\$103,509.69		
Play Sports	1	5675	\$225,130.80	7.59%	\$17,087.42	\$12,016.80		
Winners Club	1	631	\$14,069.70	2.25%	\$316.56	\$750.99		
The Jock Shop	1	2332	\$28,716.60	3.38%	\$970.62	\$1,532.80		
Totals:	4	14173	\$2,207,136.20		\$165,561.32	\$117,810.28		
Salesperson: Edyth Phillips								
Customers:	Number of Orders	Products Ordered	Total for Order	Discount (if any)	Discount Amount	Commission Earned		
-----	-----	-----	-----	-----	-----	-----		
Sports Play	2	3575	\$92,409.90	5.06%	\$4,675.94	\$3,911.43		
Winning Sports	1	11945	\$56,651.40	5.06%	\$2,866.56	\$2,397.88		
Totals:	3	15520	\$149,061.30		\$7,542.50	\$6,309.31		
Grand Totals:	33	119210	\$14,267,748.80		\$1,068,031.60	\$1,114,529.39		

Example: IGYTSALE response time from sale to ship

The following sample of IGYTSALE output shows response time between the sale date in the United States and the date the sold products are shipped to Europe.

Day of Report: Monday		COBOL		SPORTS		11/24/2003	03:12	Page: 1
				Response Time from USA Sale to European Ship				
Prod Code	Units Sold	Sale Date/Time(PST)		Ship Date	Ship Day	Response Time		
-----	-----	YYYYMMDD	HHMMSS	YYYYMMDD	Day	Days		-----
25	9999	19900226	010101	19900228	WED	.95		
15	99	19900310	100530	19900403	TUE	23.57		
05	9900	19900418	222409	19900419	THU	.06		
25	4	19900523	151010	19900623	SAT	30.36		
04	1100	19901110	003301	19901114	WED	2.97		
12	23	19901114	003205	19901117	SAT	1.97		

14	5111	19900118	101527	19900120	SAT	1.57
04	5102	19901201	132013	19901203	MON	1.44
04	300	19901221	191544	19901223	SUN	1.19
05	500	19901210	211544	19901214	FRI	3.11
04	100	19901211	000816	19901213	THU	.99
25	100	19901201	131544	19901203	MON	1.44
25	100	19901112	073312	19901113	TUE	.68
14	1111	19901214	012510	19901216	SUN	.94
26	22	19901110	000034	19901113	TUE	1.99
12	2000	19901110	154100	19901113	TUE	2.34
04	1104	19901110	175001	19901113	TUE	2.25
12	114	19901229	115522	19901230	SUN	.50
15	2000	19901110	190113	19901114	WED	3.20
10	1440	19901112	001500	19901115	THU	1.98
25	1104	19901118	120101	19901119	MON	.49
25	4	19901118	110030	19901119	MON	.54
12	144	19901114	010510	19901119	MON	3.95
14	112	19901119	010101	19901122	THU	1.95
26	321	19901117	173945	19901119	MON	1.26
13	1221	19901101	135133	19901102	FRI	.42
10	22	19901029	210000	19901030	TUE	.12
14	35	19901130	160500	19901201	SAT	.32
11	9005	19901211	050505	19901212	WED	.78
06	990	19900511	214409	19900515	TUE	3.09
13	1998	19900712	150100	19900716	MON	3.37
26	31	19901010	185559	19901011	THU	.21
14	30	19901210	195500	19901212	WED	1.17

Preparing to run IGYTSALE

All files required by the IGYTSALE program (IGYTSALE, IGYTCRC, IGYTPRC, IGYTSRC, IGYTABLE, and IGYTRANA) are on the product installation tape in the IGY.V5R1M0.SIGYSAMP data set.

You can change data-set names and procedure-names at installation time. Check with your system programmer to verify these names.

Do not change these options in the CBL statement in the source file for IGYTSALE:

- NONUMBER
- SEQUENCE
- NONUMBER
- QUOTE

With these options in effect, the program might not cause any diagnostic messages to be issued. You can use the sequence number string in the source file to search for the language elements used.

When you run IGYTSALE, the following messages are printed to the SYSOUT data set:

```

Program IGYTSALE Begins
There were 00041 records processed in this program
Program IGYTSALE Normal End

```

RELATED CONCEPTS

“IGYTSALE: nested program application” on page 812

RELATED TASKS

“Running IGYTSALE” on page 819

RELATED REFERENCES

- “Input data for IGYTSALE” on page 813
- “Reports produced by IGYTSALE” on page 815
- “Language elements and concepts that are illustrated”

Running IGYTSALE

Use the following JCL to compile, link-edit, and run the IGYTSALE program. If you want only to compile or only to compile and link-edit the program, change the IGYWCLG cataloged procedure.

Insert the accounting information for your system or installation in the fields that are shown in lowercase letters.

```
//IGYTSALE JOB (acct-info), 'IGYTSALE', MSGLEVEL=(1,1), TIME=(0,29)
//TEST EXEC IGYWCLG
//COBOL.SYSLIB DD DSN=IGY.V5R1M0.SIGYSAMP, DISP=SHR
//COBOL.SYSIN DD DSN=IGY.V5R1M0.SIGYSAMP(IGYTSALE), DISP=SHR
//GO.SYSOUT DD SYSOUT=A
//GO.IGYTABLE DD DSN=IGY.V5R1M0.SIGYSAMP(IGYTABLE), DISP=SHR
//GO.IGYTRANS DD DSN=IGY.V5R1M0.SIGYSAMP(IGYTRANA), DISP=SHR
//GO.IGYPRINT DD SYSOUT=A, DCB=BLKSIZE=133
//GO.IGYPRT2 DD SYSOUT=A, DCB=BLKSIZE=133
//
```

Language elements and concepts that are illustrated

The sample programs illustrate several COBOL language elements and concepts.

To find the applicable language element for a sample program, locate the abbreviation for that program in the sequence string:

Sample program	Abbreviation
IGYTCARA	IA
IGYTCARB	IB
IGYTSALE	IS

The following table lists the language elements and programming concepts that the sample programs illustrate. The language element or concept is described, and the sequence string is shown. The sequence string is the special character string that appears in the sequence field of the source file. You can use this string as a search argument for locating the elements in the listing.

Language element or concept	Sequence string
ACCEPT . . . FROM DAY-OF-WEEK	IS0900
ACCEPT . . . FROM DATE	IS0901
ACCEPT . . . FROM TIME	IS0902
ADD . . . TO	IS4550
AFTER ADVANCING	IS2700
AFTER PAGE	IS2600
ALL	IS4200
ASSIGN	IS1101
AUTHOR	IA0040
CALL	IS0800

Language element or concept	Sequence string
Callable services (Language Environment):	
1. CEEDATM: format date or time output	1. IS0875, IS2575
2. CEEDCOD: feedback code check	2. IS0905
3. CEEGMTO: UTC offset from local time	3. IS0904
4. CEELOCT: local date and time	4. IS0850
5. CEESECS: convert time stamp to seconds	5. IS2350, IS2550
CLOSE files	IS1900
Comma, semicolon, and space interchangeable	IS3500, IS3600
COMMON statement for nested programs	IS4600
Complex OCCURS DEPENDING ON	IS0700, IS3700
COMPUTE	IS4501
COMPUTE ROUNDED	IS4500
CONFIGURATION SECTION	IA0970
CONFIGURATION SECTION (optional)	IS0200
CONTINUE statement	IA5310, IA5380
COPY statement	IS0500
DATA DIVISION (optional)	IS5100
Data validation	IA5130-6190
Do-until (PERFORM . . . TEST AFTER)	IA4900-5010, IA7690-7770
Do-while (PERFORM . . . TEST BEFORE)	IS1660
END-ADD	IS2900
END-COMPUTE	IS4510
END-EVALUATE	IA6590, IS2450
END-IF	IS1680
END-MULTIPLY	IS3100
END-PERFORM	IS1700
END PROGRAM	IA9990
END-READ	IS1800
END-SEARCH	IS3400
ENVIRONMENT DIVISION (optional)	IS0200
Error handling, termination of program	IA4620, IA5080, IA7800-7980
EVALUATE statement	IA6270-6590
EVALUATE . . . ALSO	IS2400
EXIT PROGRAM not only statement in paragraph	IS2000
Exponentiation	IS4500
EXTERNAL clause	IS1200
FILE-CONTROL entry for sequential file	IA1190-1300
FILE-CONTROL entry for VSAM indexed file	IA1070-1180
FILE SECTION (optional)	IS0200
FILE STATUS code check	IA4600-4630, IA4760-4790
FILLER (optional)	IS0400

Language element or concept	Sequence string
Flags, level-88, definition	IA1730-1800, IA2440-2480, IA2710
Flags, level-88, testing	IA4430, IA5200-5250
FLOATING POINT	IS4400
GLOBAL statement	IS0300
INITIAL statement for nested programs	IS2300
INITIALIZE	IS2500
Initializing a table in the DATA DIVISION	IA2920-4260
Inline PERFORM statement	IA4410-4520
I-O-CONTROL paragraphs (optional)	IS0200
INPUT-OUTPUT SECTION (optional)	IS0200
Intrinsic functions:	
1. CURRENT-DATE	1. IA9005
2. MAX	2. IA9235
3. MEAN	3. IA9215
4. MEDIAN	4. IA9220
5. MIN	5. IA9240
6. STANDARD-DEVIATION	6. IA9230
7. UPPER-CASE	7. IA9015
8. VARIANCE	8. IA9225
9. WHEN-COMPILED	9. IA9000
IS (optional in all clauses)	IS0700
LABEL RECORDS (optional)	IS1150
LINKAGE SECTION	IS4900
Mixing of indexes and subscripts	IS3500
Mnemonic names	IA1000
MOVE	IS0903
MOVE CORRESPONDING statement	IA4810, IA4830
MULTIPLY . . . GIVING	IS3000
Nested IF statement, using END-IF	IA5460-5830
Nested program	IS1000
NEXT SENTENCE	IS4300
NOT AT END	IS1600
NULL	IS4800
OBJECT-COMPUTER (optional)	IS0200
OCCURS DEPENDING ON	IS0710
ODO uses maximum length for receiving item	IS1550
OPEN EXTEND	IB2210
OPEN INPUT	IS1400
OPEN OUTPUT	IS1500
ORGANIZATION (optional)	IS1100
Page eject	IA7180-7210
Parenthesis in abbreviated conditions	IS4850

Language element or concept	Sequence string
PERFORM . . . WITH TEST AFTER (Do-until)	IA4900-5010, IA7690-7770
PERFORM . . . WITH TEST BEFORE (Do-while)	IS1660
PERFORM . . . UNTIL	IS5000
PERFORM . . . VARYING statement	IA7690-7770
POINTER function	IS4700
Print file FD entry	IA1570-1620
Print report	IA7100-7360
PROCEDURE DIVISION . . . USING	IB1320-IB1650
PROGRAM-ID (30 characters allowed)	IS0120
READ . . . INTO . . . AT END	IS1550
REDEFINES statement	IA1940, IA2060, IA2890, IA3320
Reference modification	IS2425
Relational operator <= (less than or equal)	IS4400
Relational operator >= (greater than or equal)	IS2425
Relative subscripting	IS4000
REPLACE	IS4100
SEARCH statement	IS3300
SELECT	IS1100
Sequence number can contain any character	IA, IB, IS
Sequential file processing	IA4480-4510, IA4840-4870
Sequential table search, using PERFORM	IA7690-7770
Sequential table search, using SEARCH	IA5270-5320, IA5340-5390
SET INDEX	IS3200
SET . . . TO TRUE statement	IA4390, IA4500, IA4860, IA4980
SOURCE-COMPUTER (optional)	IS0200
SPECIAL-NAMES paragraph (optional)	IS0200
STRING statement	IA6950, IA7050
Support for lowercase letters	IS0100
TALLY	IS1650
TITLE statement for nested programs	IS0100
Update commuter record	IA6200-6610
Update transaction work value spaces	IB0790-IB1000
USAGE BINARY	IS1300
USAGE PACKED-DECIMAL	IS1301
Validate elements	IB0810, IB0860, IB1000
VALUE with OCCURS	IS0600
VALUE SPACE (S)	IS0601
VALUE ZERO (S) (ES)	IS0600
Variable-length table control variable	IA5100
Variable-length table definition	IA2090-2210
Variable-length table loading	IA4840-4990

Language element or concept	Sequence string
VSAM indexed file key definition	IA1170
VSAM return-code display	IA7800-7900
WORKING-STORAGE SECTION	IS0250

Notices

This information was developed for products and services offered in the U.S.A.

IBM may not offer the products, services, or features discussed in this document in other countries. Consult your local IBM representative for information on the products and services currently available in your area. Any reference to an IBM product, program, or service is not intended to state or imply that only that IBM product, program, or service may be used. Any functionally equivalent product, program, or service that does not infringe any IBM intellectual property right may be used instead. However, it is the user's responsibility to evaluate and verify the operation of any non-IBM product, program, or service.

IBM may have patents or pending patent applications covering subject matter described in this document. The furnishing of this document does not grant you any license to these patents. You can send license inquiries, in writing, to:

IBM Director of Licensing
IBM Corporation
North Castle Drive
Armonk, NY 10504-1785
U.S.A.

For license inquiries regarding double-byte (DBCS) information, contact the IBM Intellectual Property Department in your country or send inquiries, in writing, to:

Intellectual Property Licensing
Legal and Intellectual Property Law
IBM Japan, Ltd.
3-2-12, Roppongi, Minato-ku, Tokyo 106-8711

The following paragraph does not apply to the United Kingdom or any other country where such provisions are inconsistent with local law:

INTERNATIONAL BUSINESS MACHINES CORPORATION PROVIDES THIS PUBLICATION "AS IS" WITHOUT WARRANTY OF ANY KIND, EITHER EXPRESS OR IMPLIED, INCLUDING, BUT NOT LIMITED TO, THE IMPLIED WARRANTIES OF NON-INFRINGEMENT, MERCHANTABILITY OR FITNESS FOR A PARTICULAR PURPOSE. Some states do not allow disclaimer of express or implied warranties in certain transactions, therefore, this statement may not apply to you.

This information could include technical inaccuracies or typographical errors. Changes are periodically made to the information herein; these changes will be incorporated in new editions of the publication. IBM may make improvements and/or changes in the product(s) and/or the program(s) described in this publication at any time without notice.

Any references in this information to non-IBM Web sites are provided for convenience only and do not in any manner serve as an endorsement of those Web sites. The materials at those Web sites are not part of the materials for this IBM product and use of those Web sites is at your own risk.

IBM may use or distribute any of the information you supply in any way it believes appropriate without incurring any obligation to you.

Licensees of this program who wish to have information about it for the purpose of enabling: (i) the exchange of information between independently created programs and other programs (including this one) and (ii) the mutual use of the information which has been exchanged, should contact:

IBM Corporation
J46A/G4
555 Bailey Avenue
San Jose, CA 95141-1003
U.S.A.

Such information may be available, subject to appropriate terms and conditions, including in some cases, payment of a fee.

The licensed program described in this document and all licensed material available for it are provided by IBM under terms of the IBM Customer Agreement, IBM International Program License Agreement or any equivalent agreement between us.

Any performance data contained herein was determined in a controlled environment. Therefore, the results obtained in other operating environments may vary significantly. Some measurements may have been made on development-level systems and there is no guarantee that these measurements will be the same on generally available systems. Furthermore, some measurements may have been estimated through extrapolation. Actual results may vary. Users of this document should verify the applicable data for their specific environment.

Information concerning non-IBM products was obtained from the suppliers of those products, their published announcements or other publicly available sources. IBM has not tested those products and cannot confirm the accuracy of performance, compatibility or any other claims related to non-IBM products. Questions on the capabilities of non-IBM products should be addressed to the suppliers of those products.

All statements regarding IBM's future direction or intent are subject to change or withdrawal without notice, and represent goals and objectives only.

This information contains examples of data and reports used in daily business operations. To illustrate them as completely as possible, the examples include the names of individuals, companies, brands, and products. All of these names are fictitious and any similarity to the names and addresses used by an actual business enterprise is entirely coincidental.

COPYRIGHT LICENSE:

This information contains sample application programs in source language, which illustrate programming techniques on various operating platforms. You may copy, modify, and distribute these sample programs in any form without payment to IBM, for the purposes of developing, using, marketing or distributing application programs conforming to the application programming interface for the operating platform for which the sample programs are written. These examples have not been thoroughly tested under all conditions. IBM, therefore, cannot guarantee or imply reliability, serviceability, or function of these programs. The sample

programs are provided "AS IS", without warranty of any kind. IBM shall not be liable for any damages arising out of your use of the sample programs.

Each copy or any portion of these sample programs or any derivative work, must include a copyright notice as follows:

© (your company name) (year). Portions of this code are derived from IBM Corp. Sample Programs. © Copyright IBM Corp. _enter the year or years_. All rights reserved.

If you are viewing this information softcopy, the photographs and color illustrations may not appear.

Trademarks

IBM, the IBM logo, and ibm.com[®] are trademarks or registered trademarks of International Business Machines Corp., registered in many jurisdictions worldwide. Other product and service names might be trademarks of IBM or other companies. A current list of IBM trademarks is available on the Web at "Copyright and trademark information" at www.ibm.com/legal/copytrade.shtml.

Intel is a registered trademark of Intel Corporation or its subsidiaries in the United States and other countries.

Java and all Java-based trademarks and logos are trademarks or registered trademarks of Oracle and/or its affiliates.

Microsoft and Windows are trademarks of Microsoft Corporation in the United States, other countries, or both.

UNIX is a registered trademark of The Open Group in the United States and other countries.

Other product and service names might be trademarks of IBM or other companies.

Glossary

The terms in this glossary are defined in accordance with their meaning in COBOL. These terms might or might not have the same meaning in other languages.

This glossary includes terms and definitions from the following publications:

- *ANSI INCITS 23-1985, Programming languages - COBOL*, as amended by *ANSI INCITS 23a-1989, Programming Languages - COBOL - Intrinsic Function Module for COBOL*, and *ANSI INCITS 23b-1993, Programming Languages - Correction Amendment for COBOL*
- *ANSI X3.172-2002, American National Standard Dictionary for Information Systems*

American National Standard definitions are preceded by an asterisk (*).

A

* **abbreviated combined relation condition**

The combined condition that results from the explicit omission of a common subject or a common subject and common relational operator in a consecutive sequence of relation conditions.

abend Abnormal termination of a program.

above the 16 MB line

Storage above the so-called 16 MB line (or boundary) but below the 2 GB bar. This storage is addressable only in 31-bit mode. Before IBM introduced the MVS/XA architecture in the 1980s, the virtual storage for a program was limited to 16 MB. Programs that have been compiled with a 24-bit mode can address only 16 MB of space, as though they were kept under an imaginary storage line. Since VS COBOL II, a program that has been compiled with a 31-bit mode can be above the 16 MB line.

* **access mode**

The manner in which records are to be operated upon within a file.

* **actual decimal point**

The physical representation, using the

decimal point characters period (.) or comma (,), of the decimal point position in a data item.

actual document encoding

For an XML document, one of the following encoding categories that the XML parser determines by examining the first few bytes of the document:

- ASCII
- EBCDIC
- UTF-8
- UTF-16, either big-endian or little-endian
- Other unsupported encoding
- No recognizable encoding

* **alphabet-name**

A user-defined word, in the SPECIAL-NAMES paragraph of the ENVIRONMENT DIVISION, that assigns a name to a specific character set or collating sequence or both.

* **alphabetic character**

A letter or a space character.

alphabetic data item

A data item that is described with a PICTURE character string that contains only the symbol A. An alphabetic data item has USAGE DISPLAY.

* **alphanumeric character**

Any character in the single-byte character set of the computer.

alphanumeric data item

A general reference to a data item that is described implicitly or explicitly as USAGE DISPLAY, and that has category alphanumeric, alphanumeric-edited, or numeric-edited.

alphanumeric-edited data item

A data item that is described by a PICTURE character string that contains at least one instance of the symbol A or X and at least one of the simple insertion symbols B, 0, or /. An alphanumeric-edited data item has USAGE DISPLAY.

* **alphanumeric function**

A function whose value is composed of a

string of one or more characters from the alphanumeric character set of the computer.

alphanumeric group item

A group item that is defined without a GROUP-USAGE NATIONAL clause. For operations such as INSPECT, STRING, and UNSTRING, an alphanumeric group item is processed as though all its content were described as USAGE DISPLAY regardless of the actual content of the group. For operations that require processing of the elementary items within a group, such as MOVE CORRESPONDING, ADD CORRESPONDING, or INITIALIZE, an alphanumeric group item is processed using group semantics.

alphanumeric literal

A literal that has an opening delimiter from the following set: ', ', 'X', 'Z', or 'Z'. The string of characters can include any character in the character set of the computer.

*** alternate record key**

A key, other than the prime record key, whose contents identify a record within an indexed file.

ANSI (American National Standards Institute)

An organization that consists of producers, consumers, and general-interest groups and establishes the procedures by which accredited organizations create and maintain voluntary industry standards in the United States.

argument

(1) An identifier, a literal, an arithmetic expression, or a function-identifier that specifies a value to be used in the evaluation of a function. (2) An operand of the USING phrase of a CALL or INVOKE statement, used for passing values to a called program or an invoked method.

*** arithmetic expression**

An identifier of a numeric elementary item, a numeric literal, such identifiers and literals separated by arithmetic operators, two arithmetic expressions separated by an arithmetic operator, or an arithmetic expression enclosed in parentheses.

*** arithmetic operation**

The process caused by the execution of an

arithmetic statement, or the evaluation of an arithmetic expression, that results in a mathematically correct solution to the arguments presented.

*** arithmetic operator**

A single character, or a fixed two-character combination that belongs to the following set:

Character	Meaning
+	Addition
-	Subtraction
*	Multiplication
/	Division
**	Exponentiation

*** arithmetic statement**

A statement that causes an arithmetic operation to be executed. The arithmetic statements are ADD, COMPUTE, DIVIDE, MULTIPLY, and SUBTRACT.

array An aggregate that consists of data objects, each of which can be uniquely referenced by subscripting. An array is roughly analogous to a COBOL table.

*** ascending key**

A key upon the values of which data is ordered, starting with the lowest value of the key up to the highest value of the key, in accordance with the rules for comparing data items.

ASCII

American National Standard Code for Information Interchange. The standard code uses a coded character set that is based on 7-bit coded characters (8 bits including parity check). The standard is used for information interchange between data processing systems, data communication systems, and associated equipment. The ASCII set consists of control characters and graphic characters.

IBM has defined an extension to ASCII (characters 128-255).

assignment-name

A name that identifies the organization of a COBOL file and the name by which it is known to the system.

*** assumed decimal point**

A decimal point position that does not involve the existence of an actual character in a data item. The assumed

decimal point has logical meaning but no physical representation.

AT END condition

A condition that is caused during the execution of a READ, RETURN, or SEARCH statement under certain conditions:

- A READ statement runs on a sequentially accessed file when no next logical record exists in the file, or when the number of significant digits in the relative record number is larger than the size of the relative key data item, or when an optional input file is not available.
- A RETURN statement runs when no next logical record exists for the associated sort or merge file.
- A SEARCH statement runs when the search operation terminates without satisfying the condition specified in any of the associated WHEN phrases.

B

big-endian

The default format that the mainframe and the AIX workstation use to store binary data and UTF-16 characters. In this format, the least significant byte of a binary data item is at the highest address and the least significant byte of a UTF-16 character is at the highest address. Compare with *little-endian*.

binary item

A numeric data item that is represented in binary notation (on the base 2 numbering system). The decimal equivalent consists of the decimal digits 0 through 9, plus an operational sign. The leftmost bit of the item is the operational sign.

binary search

A dichotomizing search in which, at each step of the search, the set of data elements is divided by two; some appropriate action is taken in the case of an odd number.

*** block**

A physical unit of data that is normally composed of one or more logical records. For mass storage files, a block can contain a portion of a logical record. The size of a block has no direct relationship to the size of the file within which the block is contained or to the size of the logical

records that are either contained within the block or that overlap the block. Synonymous with *physical record*.

breakpoint

A place in a computer program, usually specified by an instruction, where external intervention or a monitor program can interrupt the program as it runs.

buffer

A portion of storage that is used to hold input or output data temporarily.

built-in function

See *intrinsic function*.

business method

A method of an enterprise bean that implements the business logic or rules of an application. (Oracle)

byte

A string that consists of a certain number of bits, usually eight, treated as a unit, and representing a character or a control function.

byte order mark (BOM)

A Unicode character that can be used at the start of UTF-16 or UTF-32 text to indicate the byte order of subsequent text; the byte order can be either big-endian or little-endian.

bytecode

Machine-independent code that is generated by the Java compiler and executed by the Java interpreter. (Oracle)

C

callable services

In Language Environment, a set of services that a COBOL program can invoke by using the conventional Language Environment-defined call interface. All programs that share the Language Environment conventions can use these services.

called program

A program that is the object of a CALL statement. At run time the called program and calling program are combined to produce a *run unit*.

*** calling program**

A program that executes a CALL to another program.

case structure

A program-processing logic in which a series of conditions is tested in order to choose between a number of resulting actions.

cataloged procedure

A set of job control statements that are placed in a partitioned data set called the procedure library (SYS1.PROCLIB). You can use cataloged procedures to save time and reduce errors in coding JCL.

CCSID

See *coded character set identifier*.

century window

A 100-year interval within which any two-digit year is unique. Several types of century window are available to COBOL programmers:

- For the windowing intrinsic functions DATE-TO-YYYYMMDD, DAY-TO-YYYYDDD, and YEAR-TO-YYYY, you specify the century window with *argument-2*.
- For Language Environment callable services, you specify the century window in CEESSEN.

*** character**

The basic indivisible unit of the language.

character encoding unit

A unit of data that corresponds to one code point in a coded character set. One or more character encoding units are used to represent a character in a coded character set. Also known as *encoding unit*.

For USAGE NATIONAL, a character encoding unit corresponds to one 2-byte code point of UTF-16.

For USAGE DISPLAY, a character encoding unit corresponds to a byte.

For USAGE DISPLAY-1, a character encoding unit corresponds to a 2-byte code point in the DBCS character set.

character position

The amount of physical storage or presentation space required to hold or present one character. The term applies to any class of character. For specific classes of characters, the following terms apply:

- *Alphanumeric character position*, for characters represented in USAGE DISPLAY

- *DBCS character position*, for DBCS characters represented in USAGE DISPLAY-1
- *National character position*, for characters represented in USAGE NATIONAL; synonymous with *character encoding unit* for UTF-16

character set

A collection of elements that are used to represent textual information, but for which no coded representation is assumed. See also *coded character set*.

character string

A sequence of contiguous characters that form a COBOL word, a literal, a PICTURE character string, or a comment-entry. A character string must be delimited by separators.

checkpoint

A point at which information about the status of a job and the system can be recorded so that the job step can be restarted later.

*** class**

The entity that defines common behavior and implementation for zero, one, or more objects. The objects that share the same implementation are considered to be objects of the same class. Classes can be defined hierarchically, allowing one class to inherit from another.

*** class condition**

The proposition (for which a truth value can be determined) that the content of an item is wholly alphabetic, is wholly numeric, is wholly DBCS, is wholly Kanji, or consists exclusively of the characters that are listed in the definition of a class-name.

*** class definition**

The COBOL source unit that defines a class.

class hierarchy

A tree-like structure that shows relationships among object classes. It places one class at the top and one or more layers of classes below it. Synonymous with *inheritance hierarchy*.

*** class identification entry**

An entry in the CLASS-ID paragraph of the IDENTIFICATION DIVISION; this entry contains clauses that specify the

class-name and assign selected attributes to the class definition.

class-name (object-oriented)

The name of an object-oriented COBOL class definition.

*** class-name (of data)**

A user-defined word that is defined in the SPECIAL-NAMES paragraph of the ENVIRONMENT DIVISION; this word assigns a name to the proposition (for which a truth value can be defined) that the content of a data item consists exclusively of the characters that are listed in the definition of the class-name.

class object

The runtime object that represents a class.

*** clause**

An ordered set of consecutive COBOL character strings whose purpose is to specify an attribute of an entry.

client In object-oriented programming, a program or method that requests services from one or more methods in a class.

COBOL character set

The set of characters used in writing COBOL syntax. The complete COBOL character set consists of these characters:

Character	Meaning
0,1, . . . ,9	Digit
A,B, . . . ,Z	Uppercase letter
a,b, . . . ,z	Lowercase letter
	Space
+	Plus sign
-	Minus sign (hyphen)
*	Asterisk
/	Slant (forward slash)
=	Equal sign
\$	Currency sign
,	Comma
;	Semicolon
.	Period (decimal point, full stop)
"	Quotation mark
'	Apostrophe
(Left parenthesis
)	Right parenthesis
>	Greater than
<	Less than
:	Colon
_	Underscore

*** COBOL word**
See *word*.

code page

An assignment of graphic characters and control function meanings to all code points. For example, one code page could assign characters and meanings to 256 code points for 8-bit code, and another code page could assign characters and meanings to 128 code points for 7-bit code. For example, one of the IBM code pages for English on the workstation is IBM-1252 and on the host is IBM-1047. A *coded character set*.

code point

A unique bit pattern that is defined in a coded character set (code page). Graphic symbols and control characters are assigned to code points.

coded character set

A set of unambiguous rules that establish a character set and the relationship between the characters of the set and their coded representation. Examples of coded character sets are the character sets as represented by ASCII or EBCDIC code pages or by the UTF-16 encoding scheme for Unicode.

coded character set identifier (CCSID)

An IBM-defined number in the range 1 to 65,535 that identifies a specific code page.

*** collating sequence**

The sequence in which the characters that are acceptable to a computer are ordered for purposes of sorting, merging, comparing, and for processing indexed files sequentially.

*** column**

A byte position within a print line or within a reference format line. The columns are numbered from 1, by 1, starting at the leftmost position of the line and extending to the rightmost position of the line. A column holds one single-byte character.

*** combined condition**

A condition that is the result of connecting two or more conditions with the AND or the OR logical operator. See also *condition* and *negated combined condition*.

*** comment-entry**

An entry in the IDENTIFICATION DIVISION that can be any combination of characters from the character set of the computer.

comment line

A source program line represented by an asterisk (*) in the indicator area of the line and any characters from the character set of the computer that follow in Area A and Area B of that line. A comment line serves only for documentation. A special form of comment line represented by a slant (/) in the indicator area of the line and any characters from the character set of the computer in Area A and Area B of that line causes page ejection before the comment is printed.

*** common program**

A program that, despite being directly contained within another program, can be called from any program directly or indirectly contained in that other program.

*** compile**

(1) To translate a program expressed in a high-level language into a program expressed in an intermediate language, assembly language, or a computer language. (2) To prepare a machine-language program from a computer program written in another programming language by making use of the overall logic structure of the program, or generating more than one computer instruction for each symbolic statement, or both, as well as performing the function of an assembler.

*** compile time**

The time at which COBOL source code is translated, by a COBOL compiler, to a COBOL object program.

compiler

A program that translates source code written in a higher-level language into machine-language object code.

compiler-directing statement

A statement that causes the compiler to take a specific action during compilation. The standard compiler-directing statements are COPY, REPLACE, and USE.

*** complex condition**

A condition in which one or more logical operators act upon one or more conditions. See also *condition*, *negated simple condition*, and *negated combined condition*.

complex ODO

Certain forms of the OCCURS DEPENDING ON clause:

- Variably located item or group: A data item described by an OCCURS clause with the DEPENDING ON option is followed by a nonsubordinate data item or group. The group can be an alphanumeric group or a national group.
- Variably located table: A data item described by an OCCURS clause with the DEPENDING ON option is followed by a nonsubordinate data item described by an OCCURS clause.
- Table with variable-length elements: A data item described by an OCCURS clause contains a subordinate data item described by an OCCURS clause with the DEPENDING ON option.
- Index name for a table with variable-length elements.
- Element of a table with variable-length elements.

component

(1) A functional grouping of related files. (2) In object-oriented programming, a reusable object or program that performs a specific function and is designed to work with other components and applications. JavaBeans is Oracle's architecture for creating components.

*** computer-name**

A system-name that identifies the computer where the program is to be compiled or run.

condition (exception)

An exception that has been enabled, or recognized, by Language Environment and thus is eligible to activate user and language condition handlers. Any alteration to the normal programmed flow of an application. Conditions can be detected by the hardware or the operating system and result in an interrupt. They can also be detected by language-specific generated code or language library code.

condition (expression)

A status of data at run time for which a truth value can be determined. Where used in this information in or in reference to "condition" (*condition-1*, *condition-2*, . . .) of a general format, the term refers to a

conditional expression that consists of either a simple condition optionally parenthesized or a combined condition (consisting of the syntactically correct combination of simple conditions, logical operators, and parentheses) for which a truth value can be determined. See also *simple condition*, *complex condition*, *negated simple condition*, *combined condition*, and *negated combined condition*.

*** conditional expression**

A simple condition or a complex condition specified in an EVALUATE, IF, PERFORM, or SEARCH statement. See also *simple condition* and *complex condition*.

*** conditional phrase**

A phrase that specifies the action to be taken upon determination of the truth value of a condition that results from the execution of a conditional statement.

*** conditional statement**

A statement that specifies that the truth value of a condition is to be determined and that the subsequent action of the object program depends on this truth value.

*** conditional variable**

A data item one or more values of which has a condition-name assigned to it.

*** condition-name**

A user-defined word that assigns a name to a subset of values that a conditional variable can assume; or a user-defined word assigned to a status of an implementor-defined switch or device.

*** condition-name condition**

The proposition (for which a truth value can be determined) that the value of a conditional variable is a member of the set of values attributed to a condition-name associated with the conditional variable.

*** CONFIGURATION SECTION**

A section of the ENVIRONMENT DIVISION that describes overall specifications of source and object programs and class definitions.

CONSOLE

A COBOL environment-name associated with the operator console.

contained program

A COBOL program that is nested within another COBOL program.

*** contiguous items**

Items that are described by consecutive entries in the DATA DIVISION, and that bear a definite hierarchic relationship to each other.

copybook

A file or library member that contains a sequence of code that is included in the source program at compile time using the COPY statement. The file can be created by the user, supplied by COBOL, or supplied by another product. Synonymous with *copy file*.

*** counter**

A data item used for storing numbers or number representations in a manner that permits these numbers to be increased or decreased by the value of another number, or to be changed or reset to zero or to an arbitrary positive or negative value.

cross-reference listing

The portion of the compiler listing that contains information on where files, fields, and indicators are defined, referenced, and modified in a program.

currency-sign value

A character string that identifies the monetary units stored in a numeric-edited item. Typical examples are \$, USD, and EUR. A currency-sign value can be defined by either the CURRENCY compiler option or the CURRENCY SIGN clause in the SPECIAL-NAMES paragraph of the ENVIRONMENT DIVISION. If the CURRENCY SIGN clause is not specified and the NOCURRENCY compiler option is in effect, the dollar sign (\$) is used as the default currency-sign value. See also *currency symbol*.

currency symbol

A character used in a PICTURE clause to indicate the position of a currency sign value in a numeric-edited item. A currency symbol can be defined by either the CURRENCY compiler option or the CURRENCY SIGN clause in the SPECIAL-NAMES paragraph of the ENVIRONMENT DIVISION. If the CURRENCY SIGN clause is not specified and the

NOCURRENCY compiler option is in effect, the dollar sign (\$) is used as the default currency sign value and currency symbol. Multiple currency symbols and currency sign values can be defined. See also *currency sign value*.

*** current record**

In file processing, the record that is available in the record area associated with a file.

*** current volume pointer**

A conceptual entity that points to the current volume of a sequential file.

D

*** data clause**

A clause, appearing in a data description entry in the DATA DIVISION of a COBOL program, that provides information describing a particular attribute of a data item.

*** data description entry**

An entry in the DATA DIVISION of a COBOL program that is composed of a level-number followed by a data-name, if required, and then followed by a set of data clauses, as required.

DATA DIVISION

The division of a COBOL program or method that describes the data to be processed by the program or method: the files to be used and the records contained within them; internal WORKING-STORAGE records that will be needed; data to be made available in more than one program in the COBOL run unit.

*** data item**

A unit of data (excluding literals) defined by a COBOL program or by the rules for function evaluation.

data set

Synonym for *file*.

*** data-name**

A user-defined word that names a data item described in a data description entry. When used in the general formats, data-name represents a word that must not be reference-modified, subscripted, or qualified unless specifically permitted by the rules for the format.

DBCS See *double-byte character set (DBCS)*.

DBCS character

Any character defined in IBM's double-byte character set.

DBCS character position

See *character position*.

DBCS data item

A data item that is described by a PICTURE character string that contains at least one symbol G, or, when the NSYMBOL (DBCS) compiler option is in effect, at least one symbol N. A DBCS data item has USAGE DISPLAY-1.

*** debugging line**

Any line with a D in the indicator area of the line.

*** debugging section**

A section that contains a USE FOR DEBUGGING statement.

*** declarative sentence**

A compiler-directing sentence that consists of a single USE statement terminated by the separator period.

*** declaratives**

A set of one or more special-purpose sections, written at the beginning of the PROCEDURE DIVISION, the first of which is preceded by the key word DECLARATIVE and the last of which is followed by the key words END DECLARATIVES. A declarative is composed of a section header, followed by a USE compiler-directing sentence, followed by a set of zero, one, or more associated paragraphs.

*** de-edit**

The logical removal of all editing characters from a numeric-edited data item in order to determine the unedited numeric value of the item.

*** delimited scope statement**

Any statement that includes its explicit scope terminator.

*** delimiter**

A character or a sequence of contiguous characters that identify the end of a string of characters and separate that string of characters from the following string of characters. A delimiter is not part of the string of characters that it delimits.

dependent region

In IMS, the MVS virtual storage region

that contains message-driven programs, batch programs, or online utilities.

*** descending key**

A key upon the values of which data is ordered starting with the highest value of key down to the lowest value of key, in accordance with the rules for comparing data items.

digit Any of the numerals from 0 through 9. In COBOL, the term is not used to refer to any other symbol.

*** digit position**

The amount of physical storage required to store a single digit. This amount can vary depending on the usage specified in the data description entry that defines the data item.

*** direct access**

The facility to obtain data from storage devices or to enter data into a storage device in such a way that the process depends only on the location of that data and not on a reference to data previously accessed.

display floating-point data item

A data item that is described implicitly or explicitly as USAGE DISPLAY and that has a PICTURE character string that describes an external floating-point data item.

*** division**

A collection of zero, one, or more sections or paragraphs, called the division body, that are formed and combined in accordance with a specific set of rules. Each division consists of the division header and the related division body. There are four divisions in a COBOL program: Identification, Environment, Data, and Procedure.

*** division header**

A combination of words followed by a separator period that indicates the beginning of a division. The division headers are:

IDENTIFICATION DIVISION.
ENVIRONMENT DIVISION.
DATA DIVISION.
PROCEDURE DIVISION.

DLL See *dynamic link library (DLL)*.

DLL application

An application that references imported programs, functions, or variables.

DLL linkage

A CALL in a program that has been compiled with the DLL and NODYNAM options; the CALL resolves to an exported name in a separate module, or to an INVOKE of a method that is defined in a separate module.

do construct

In structured programming, a DO statement is used to group a number of statements in a procedure. In COBOL, an inline PERFORM statement functions in the same way.

do-until

In structured programming, a do-until loop will be executed at least once, and until a given condition is true. In COBOL, a TEST AFTER phrase used with the PERFORM statement functions in the same way.

do-while

In structured programming, a do-while loop will be executed if, and while, a given condition is true. In COBOL, a TEST BEFORE phrase used with the PERFORM statement functions in the same way.

document type declaration

An XML element that contains or points to markup declarations that provide a grammar for a class of documents. This grammar is known as a document type definition, or DTD.

document type definition (DTD)

The grammar for a class of XML documents. See *document type declaration*.

double-byte character set (DBCS)

A set of characters in which each character is represented by 2 bytes. Languages such as Japanese, Chinese, and Korean, which contain more symbols than can be represented by 256 code points, require double-byte character sets. Because each character requires 2 bytes, entering, displaying, and printing DBCS characters requires hardware and supporting software that are DBCS-capable.

DWARF

DWARF was developed by the UNIX International Programming Languages Special Interest Group (SIG). It is designed to meet the symbolic,

source-level debugging needs of different languages in a unified fashion by supplying language-independent debugging information. A DWARF file contains debugging data organized into different elements. For more information, see *DWARF program information* in the *DWARF/ELF Extensions Library Reference*.

*** dynamic access**

An access mode in which specific logical records can be obtained from or placed into a mass storage file in a nonsequential manner and obtained from a file in a sequential manner during the scope of the same OPEN statement.

dynamic CALL

A CALL *literal* statement in a program that has been compiled with the DYNAM option and the NODLL option, or a CALL *identifier* statement in a program that has been compiled with the NODLL option.

dynamic link library (DLL)

A file that contains executable code and data that are bound to a program at load time or run time, rather than during linking. Several applications can share the code and data in a DLL simultaneously. Although a DLL is not part of the executable file for a program, it can be required for an executable file to run properly.

dynamic storage area (DSA)

Dynamically acquired storage composed of a register save area and an area available for dynamic storage allocation (such as program variables). A DSA is allocated upon invocation of a program or function and persists for the duration of the invocation instance. DSAs are generally allocated within stack segments managed by Language Environment.

*** EBCDIC (Extended Binary-Coded Decimal Interchange Code)**

A coded character set based on 8-bit coded characters.

EBCDIC character

Any one of the symbols included in the EBCDIC (Extended Binary-Coded-Decimal Interchange Code) set.

edited data item

A data item that has been modified by suppressing zeros or inserting editing characters or both.

*** editing character**

A single character or a fixed two-character combination belonging to the following set:

Character	Meaning
	Space
0	Zero
+	Plus
-	Minus
CR	Credit
DB	Debit
Z	Zero suppress
*	Check protect
\$	Currency sign
,	Comma (decimal point)
.	Period (decimal point)
/	Slant (forward slash)

EJB See *Enterprise JavaBeans*.

EJB container

A container that implements the EJB component contract of the J2EE architecture. This contract specifies a runtime environment for enterprise beans that includes security, concurrency, life cycle management, transaction, deployment, and other services. An EJB container is provided by an EJB or J2EE server. (Oracle)

EJB server

Software that provides services to an EJB container. An EJB server can host one or more EJB containers. (Oracle)

element (text element)

One logical unit of a string of text, such as the description of a single data item or verb, preceded by a unique code identifying the element type.

*** elementary item**

A data item that is described as not being further logically subdivided.

encapsulation

In object-oriented programming, the technique that is used to hide the inherent details of an object. The object provides an interface that queries and manipulates

the data without exposing its underlying structure. Synonymous with *information hiding*.

enclave

When running under Language Environment, an enclave is analogous to a run unit. An enclave can create other enclaves by using LINK and by using the system() function in C.

encoding unit

See *character encoding unit*.

end class marker

A combination of words, followed by a separator period, that indicates the end of a COBOL class definition. The end class marker is:

END CLASS *class-name*.

end method marker

A combination of words, followed by a separator period, that indicates the end of a COBOL method definition. The end method marker is:

END METHOD *method-name*.

*** end of PROCEDURE DIVISION**

The physical position of a COBOL source program after which no further procedures appear.

*** end program marker**

A combination of words, followed by a separator period, that indicates the end of a COBOL source program. The end program marker is:

END PROGRAM *program-name*.

enterprise bean

A component that implements a business task and resides in an EJB container. (Oracle)

Enterprise JavaBeans

A component architecture defined by Oracle for the development and deployment of object-oriented, distributed, enterprise-level applications.

*** entry**

Any descriptive set of consecutive clauses terminated by a separator period and written in the IDENTIFICATION DIVISION, ENVIRONMENT DIVISION, or DATA DIVISION of a COBOL program.

*** environment clause**

A clause that appears as part of an ENVIRONMENT DIVISION entry.

ENVIRONMENT DIVISION

One of the four main component parts of a COBOL program, class definition, or method definition. The ENVIRONMENT DIVISION describes the computers where the source program is compiled and those where the object program is run. It provides a linkage between the logical concept of files and their records, and the physical aspects of the devices on which files are stored.

environment-name

A name, specified by IBM, that identifies system logical units, printer and card punch control characters, report codes, program switches or all of these. When an environment-name is associated with a mnemonic-name in the ENVIRONMENT DIVISION, the mnemonic-name can be substituted in any format in which such substitution is valid.

environment variable

Any of a number of variables that define some aspect of the computing environment, and are accessible to programs that operate in that environment. Environment variables can affect the behavior of programs that are sensitive to the environment in which they operate.

execution time

See *run time*.

execution-time environment

See *runtime environment*.

*** explicit scope terminator**

A reserved word that terminates the scope of a particular PROCEDURE DIVISION statement.

exponent

A number that indicates the power to which another number (the base) is to be raised. Positive exponents denote multiplication; negative exponents denote division; and fractional exponents denote a root of a quantity. In COBOL, an exponential expression is indicated with the symbol ** followed by the exponent.

*** expression**

An arithmetic or conditional expression.

*** extend mode**

The state of a file after execution of an OPEN statement, with the EXTEND phrase specified for that file, and before the execution of a CLOSE statement, without the REEL or UNIT phrase for that file.

Extensible Markup Language

See *XML*.

extensions

COBOL syntax and semantics supported by IBM compilers in addition to those described in the 85 COBOL Standard.

external code page

For XML documents, the value specified by the CODEPAGE compiler option.

*** external data**

The data that is described in a program as external data items and external file connectors.

*** external data item**

A data item that is described as part of an external record in one or more programs of a run unit and that can be referenced from any program in which it is described.

*** external data record**

A logical record that is described in one or more programs of a run unit and whose constituent data items can be referenced from any program in which they are described.

external decimal data item

See *zoned decimal data item* and *national decimal data item*.

*** external file connector**

A file connector that is accessible to one or more object programs in the run unit.

external floating-point data item

See *display floating-point data item* and *national floating-point data item*.

external program

The outermost program. A program that is not nested.

*** external switch**

A hardware or software device, defined and named by the implementor, which is used to indicate that one of two alternate states exists.

factory data

Data that is allocated once for a class and shared by all instances of the class. Factory data is declared in the WORKING-STORAGE SECTION of the DATA DIVISION in the FACTORY paragraph of the class definition, and is equivalent to Java private static data.

factory method

A method that is supported by a class independently of an object instance. Factory methods are declared in the FACTORY paragraph of the class definition, and are equivalent to Java public static methods. They are typically used to customize the creation of objects.

*** figurative constant**

A compiler-generated value referenced through the use of certain reserved words.

*** file** A collection of logical records.

*** file attribute conflict condition**

An unsuccessful attempt has been made to execute an input-output operation on a file and the file attributes, as specified for that file in the program, do not match the fixed attributes for that file.

*** file clause**

A clause that appears as part of any of the following DATA DIVISION entries: file description entry (FD entry) and sort-merge file description entry (SD entry).

*** file connector**

A storage area that contains information about a file and is used as the linkage between a file-name and a physical file and between a file-name and its associated record area.

*** file control entry**

A SELECT clause and all its subordinate clauses that declare the relevant physical attributes of a file.

FILE-CONTROL paragraph

A paragraph in the ENVIRONMENT DIVISION in which the data files for a given source unit are declared.

*** file description entry**

An entry in the FILE SECTION of the DATA DIVISION that is composed of the level

F

indicator FD, followed by a file-name, and then followed by a set of file clauses as required.

*** file-name**

A user-defined word that names a file connector described in a file description entry or a sort-merge file description entry within the FILE SECTION of the DATA DIVISION.

*** file organization**

The permanent logical file structure established at the time that a file is created.

file position indicator

A conceptual entity that contains the value of the current key within the key of reference for an indexed file, or the record number of the current record for a sequential file, or the relative record number of the current record for a relative file, or indicates that no next logical record exists, or that an optional input file is not available, or that the AT END condition already exists, or that no valid next record has been established.

*** FILE SECTION**

The section of the DATA DIVISION that contains file description entries and sort-merge file description entries together with their associated record descriptions.

file system

The collection of files that conform to a specific set of data-record and file-description protocols, and a set of programs that manage these files.

*** fixed file attributes**

Information about a file that is established when a file is created and that cannot subsequently be changed during the existence of the file. These attributes include the organization of the file (sequential, relative, or indexed), the prime record key, the alternate record keys, the code set, the minimum and maximum record size, the record type (fixed or variable), the collating sequence of the keys for indexed files, the blocking factor, the padding character, and the record delimiter.

*** fixed-length record**

A record associated with a file whose file description or sort-merge description

entry requires that all records contain the same number of bytes.

fixed-point item

A numeric data item defined with a PICTURE clause that specifies the location of an optional sign, the number of digits it contains, and the location of an optional decimal point. The format can be either binary, packed decimal, or external decimal.

floating point

A format for representing numbers in which a real number is represented by a pair of distinct numerals. In a floating-point representation, the real number is the product of the fixed-point part (the first numeral) and a value obtained by raising the implicit floating-point base to a power denoted by the exponent (the second numeral). For example, a floating-point representation of the number 0.0001234 is 0.1234 -3, where 0.1234 is the mantissa and -3 is the exponent.

floating-point data item

A numeric data item that contains a fraction and an exponent. Its value is obtained by multiplying the fraction by the base of the numeric data item raised to the power that the exponent specifies.

*** format**

A specific arrangement of a set of data.

*** function**

A temporary data item whose value is determined at the time the function is referenced during the execution of a statement.

*** function-identifier**

A syntactically correct combination of character strings and separators that references a function. The data item represented by a function is uniquely identified by a function-name with its arguments, if any. A function-identifier can include a reference-modifier. A function-identifier that references an alphanumeric function can be specified anywhere in the general formats that an identifier can be specified, subject to certain restrictions. A function-identifier that references an integer or numeric function can be referenced anywhere in

the general formats that an arithmetic expression can be specified.

function-name

A word that names the mechanism whose invocation, along with required arguments, determines the value of a function.

function-pointer data item

A data item in which a pointer to an entry point can be stored. A data item defined with the USAGE IS FUNCTION-POINTER clause contains the address of a function entry point. Typically used to communicate with C and Java programs.

G

garbage collection

The automatic freeing by the Java runtime system of the memory for objects that are no longer referenced.

*** global name**

A name that is declared in only one program but that can be referenced from the program and from any program contained within the program. Condition-names, data-names, file-names, record-names, report-names, and some special registers can be global names.

global reference

A reference to an object that is outside the scope of a method.

group item

(1) A data item that is composed of subordinate data items. See *alphanumeric group item* and *national group item*. (2) When not qualified explicitly or by context as a national group or an alphanumeric group, the term refers to groups in general.

grouping separator

A character used to separate units of digits in numbers for ease of reading. The default is the character comma.

H

header label

(1) A data-set label that precedes the data records in a unit of recording media. (2) Synonym for *beginning-of-file label*.

hide To redefine a factory or static method (inherited from a parent class) in a subclass.

*** high-order end**

The leftmost character of a string of characters.

hiperspace

In a z/OS environment, a range of up to 2 GB of contiguous virtual storage addresses that a program can use as a buffer.

I

IBM COBOL extension

COBOL syntax and semantics supported by IBM compilers in addition to those described in the 85 COBOL Standard.

IDENTIFICATION DIVISION

One of the four main component parts of a COBOL program, class definition, or method definition. The IDENTIFICATION DIVISION identifies the program, class, or method. The IDENTIFICATION DIVISION can include the following documentation: author name, installation, or date.

*** identifier**

A syntactically correct combination of character strings and separators that names a data item. When referencing a data item that is not a function, an identifier consists of a data-name, together with its qualifiers, subscripts, and reference-modifier, as required for uniqueness of reference. When referencing a data item that is a function, a function-identifier is used.

*** imperative statement**

A statement that either begins with an imperative verb and specifies an unconditional action to be taken or is a conditional statement that is delimited by its explicit scope terminator (delimited scope statement). An imperative statement can consist of a sequence of imperative statements.

*** implicit scope terminator**

A separator period that terminates the scope of any preceding unterminated statement, or a phrase of a statement that by its occurrence indicates the end of the scope of any statement contained within the preceding phrase.

- * index**
A computer storage area or register, the content of which represents the identification of a particular element in a table.
- * index data item**
A data item in which the values associated with an index-name can be stored in a form specified by the implementor.
- indexed data-name**
An identifier that is composed of a data-name, followed by one or more index-names enclosed in parentheses.
- * indexed file**
A file with indexed organization.
- * indexed organization**
The permanent logical file structure in which each record is identified by the value of one or more keys within that record.
- indexing**
Synonymous with *subscripting* using index-names.
- * index-name**
A user-defined word that names an index associated with a specific table.
- inheritance**
A mechanism for using the implementation of a class as the basis for another class. By definition, the inheriting class conforms to the inherited classes. Enterprise COBOL does not support *multiple inheritance*; a subclass has exactly one immediate superclass.
- inheritance hierarchy**
See *class hierarchy*.
- * initial program**
A program that is placed into an initial state every time the program is called in a run unit.
- * initial state**
The state of a program when it is first called in a run unit.
- inline**
In a program, instructions that are executed sequentially, without branching to routines, subroutines, or other programs.
- * input file**
A file that is opened in the input mode.
- * input mode**
The state of a file after execution of an OPEN statement, with the INPUT phrase specified, for that file and before the execution of a CLOSE statement, without the REEL or UNIT phrase for that file.
- * input-output file**
A file that is opened in the I-O mode.
- * INPUT-OUTPUT SECTION**
The section of the ENVIRONMENT DIVISION that names the files and the external media required by an object program or method and that provides information required for transmission and handling of data at run time.
- * input-output statement**
A statement that causes files to be processed by performing operations on individual records or on the file as a unit. The input-output statements are ACCEPT (with the identifier phrase), CLOSE, DELETE, DISPLAY, OPEN, READ, REWRITE, SET (with the TO ON or TO OFF phrase), START, and WRITE.
- * input procedure**
A set of statements, to which control is given during the execution of a format 1 SORT statement, for the purpose of controlling the release of specified records to be sorted.
- instance data**
Data that defines the state of an object. The instance data introduced by a class is defined in the WORKING-STORAGE SECTION of the DATA DIVISION in the OBJECT paragraph of the class definition. The state of an object also includes the state of the instance variables introduced by classes that are inherited by the current class. A separate copy of the instance data is created for each object instance.
- * integer**
(1) A numeric literal that does not include any digit positions to the right of the decimal point. (2) A numeric data item defined in the DATA DIVISION that does not include any digit positions to the right of the decimal point. (3) A numeric function whose definition provides that all digits to the right of the decimal point

are zero in the returned value for any possible evaluation of the function.

integer function

A function whose category is numeric and whose definition does not include any digit positions to the right of the decimal point.

Interactive System Productivity Facility (ISPF)

An IBM software product that provides a menu-driven interface for the TSO or VM user. ISPF includes library utilities, a powerful editor, and dialog management.

interlanguage communication (ILC)

The ability of routines written in different programming languages to communicate. ILC support lets you readily build applications from component routines written in a variety of languages.

intermediate result

An intermediate field that contains the results of a succession of arithmetic operations.

*** internal data**

The data that is described in a program and excludes all external data items and external file connectors. Items described in the LINKAGE SECTION of a program are treated as internal data.

*** internal data item**

A data item that is described in one program in a run unit. An internal data item can have a global name.

internal decimal data item

A data item that is described as USAGE PACKED-DECIMAL or USAGE COMP-3, and that has a PICTURE character string that defines the item as numeric (a valid combination of symbols 9, S, P, or V). Synonymous with *packed-decimal data item*.

*** internal file connector**

A file connector that is accessible to only one object program in the run unit.

internal floating-point data item

A data item that is described as USAGE COMP-1 or USAGE COMP-2. COMP-1 defines a single-precision floating-point data item. COMP-2 defines a double-precision floating-point data item. There is no PICTURE clause associated with an internal floating-point data item.

*** intrarecord data structure**

The entire collection of groups and elementary data items from a logical record that a contiguous subset of the data description entries defines. These data description entries include all entries whose level-number is greater than the level-number of the first data description entry describing the intra-record data structure.

intrinsic function

A predefined function, such as a commonly used arithmetic function, called by a built-in function reference.

*** invalid key condition**

A condition, at run time, caused when a specific value of the key associated with an indexed or relative file is determined to be not valid.

*** I-O-CONTROL**

The name of an ENVIRONMENT DIVISION paragraph in which object program requirements for rerun points, sharing of same areas by several data files, and multiple file storage on a single input-output device are specified.

*** I-O-CONTROL entry**

An entry in the I-O-CONTROL paragraph of the ENVIRONMENT DIVISION; this entry contains clauses that provide information required for the transmission and handling of data on named files during the execution of a program.

*** I-O mode**

The state of a file after execution of an OPEN statement, with the I-0 phrase specified, for that file and before the execution of a CLOSE statement without the REEL or UNIT phrase for that file.

*** I-O status**

A conceptual entity that contains the two-character value indicating the resulting status of an input-output operation. This value is made available to the program through the use of the FILE STATUS clause in the file control entry for the file.

is-a

A relationship that characterizes classes and subclasses in an inheritance hierarchy. Subclasses that have an is-a relationship to a class inherit from that class.

ISPF See *Interactive System Productivity Facility (ISPF)*.

iteration structure

A program processing logic in which a series of statements is repeated while a condition is true or until a condition is true.

J

J2EE See *Java 2 Platform, Enterprise Edition (J2EE)*.

Java 2 Platform, Enterprise Edition (J2EE)

An environment for developing and deploying enterprise applications, defined by Oracle. The J2EE platform consists of a set of services, application programming interfaces (APIs), and protocols that provide the functionality for developing multitiered, Web-based applications. (Oracle)

Java batch-processing program (JBP)

An IMS batch-processing program that has access to online databases and output message queues. JBPs run online, but like programs in a batch environment, they are started with JCL or in a TSO session.

Java batch-processing region

An IMS dependent region in which only Java batch-processing programs are scheduled.

Java Database Connectivity (JDBC)

A specification from Oracle that defines an API that enables Java programs to access databases.

Java message-processing program (JMP)

A Java application program that is driven by transactions and has access to online IMS databases and message queues.

Java message-processing region

An IMS dependent region in which only Java message-processing programs are scheduled.

Java Native Interface (JNI)

A programming interface that lets Java code that runs inside a Java virtual machine (JVM) interoperate with applications and libraries written in other programming languages.

Java virtual machine (JVM)

A software implementation of a central processing unit that runs compiled Java programs.

JavaBeans

A portable, platform-independent, reusable component model. (Oracle)

JBP See *Java batch-processing program (JBP)*.

JDBC See *Java Database Connectivity (JDBC)*.

JMP See *Java message-processing program (JMP)*.

job control language (JCL)

A control language used to identify a job to an operating system and to describe the job's requirements.

JVM See *Java virtual machine (JVM)*.

K

K When referring to storage capacity, two to the tenth power; 1024 in decimal notation.

* **key** A data item that identifies the location of a record, or a set of data items that serve to identify the ordering of data.

* **key of reference**

The key, either prime or alternate, currently being used to access records within an indexed file.

* **keyword**

A reserved word or function-name whose presence is required when the format in which the word appears is used in a source program.

kilobyte (KB)

One kilobyte equals 1024 bytes.

L

* **language-name**

A system-name that specifies a particular programming language.

Language Environment-conforming

A characteristic of compiler products (such as Enterprise COBOL, COBOL for OS/390 & VM, COBOL for MVS & VM, C/C++ for MVS & VM, PL/I for MVS & VM) that produce object code conforming to the Language Environment conventions.

last-used state

A state that a program is in if its internal values remain the same as when the

program was exited (the values are not reset to their initial values).

*** letter**

A character belonging to one of the following two sets:

1. Uppercase letters: A, B, C, D, E, F, G, H, I, J, K, L, M, N, O, P, Q, R, S, T, U, V, W, X, Y, Z
2. Lowercase letters: a, b, c, d, e, f, g, h, i, j, k, l, m, n, o, p, q, r, s, t, u, v, w, x, y, z

*** level indicator**

Two alphabetic characters that identify a specific type of file or a position in a hierarchy. The level indicators in the DATA DIVISION are: CD, FD, and SD.

*** level-number**

A user-defined word (expressed as a two-digit number) that indicates the hierarchical position of a data item or the special properties of a data description entry. Level-numbers in the range from 1 through 49 indicate the position of a data item in the hierarchical structure of a logical record. Level-numbers in the range 1 through 9 can be written either as a single digit or as a zero followed by a significant digit. Level-numbers 66, 77, and 88 identify special properties of a data description entry.

*** library-name**

A user-defined word that names a COBOL library that the compiler is to use for compiling a given source program.

*** library text**

A sequence of text words, comment lines, the separator space, or the separator pseudo-text delimiter in a COBOL library.

Lilian date

The number of days since the beginning of the Gregorian calendar. Day one is Friday, October 15, 1582. The Lilian date format is named in honor of Luigi Lilio, the creator of the Gregorian calendar.

*** lineage-counter**

A special register whose value points to the current position within the page body.

link

(1) The combination of the link connection (the transmission medium) and two link stations, one at each end of the link connection. A link can be shared among

multiple links in a multipoint or token-ring configuration. (2) To interconnect items of data or portions of one or more computer programs; for example, linking object programs by a linkage-editor to produce an executable file.

LINKAGE SECTION

The section in the DATA DIVISION of the called program or invoked method that describes data items available from the calling program or invoking method. Both the calling program or invoking method and the called program or invoked method can refer to these data items.

linker A term that refers to either the z/OS binder (linkage-editor).

literal

A character string whose value is specified either by the ordered set of characters comprising the string or by the use of a figurative constant.

little-endian

The default format that Intel processors use to store binary data and UTF-16 characters. In this format, the most significant byte of a binary data item is at the highest address and the most significant byte of a UTF-16 character is at the highest address. Compare with *big-endian*.

local reference

A reference to an object that is within the scope of your method.

locale

A set of attributes for a program execution environment that indicates culturally sensitive considerations, such as character code page, collating sequence, date and time format, monetary value representation, numeric value representation, or language.

*** LOCAL-STORAGE SECTION**

The section of the DATA DIVISION that defines storage that is allocated and freed on a per-invocation basis, depending on the value assigned in the VALUE clauses.

*** logical operator**

One of the reserved words AND, OR, or NOT. In the formation of a condition, either AND, or OR, or both can be used as logical connectives. NOT can be used for logical negation.

*** logical record**

The most inclusive data item. The level-number for a record is 01. A record can be either an elementary item or a group of items. Synonymous with *record*.

*** low-order end**

The rightmost character of a string of characters.

M

main program

In a hierarchy of programs and subroutines, the first program that receives control when the programs are run within a process.

makefile

A text file that contains a list of the files for your application. The make utility uses this file to update the target files with the latest changes.

*** mass storage**

A storage medium in which data can be organized and maintained in both a sequential manner and a nonsequential manner.

*** mass storage device**

A device that has a large storage capacity, such as a magnetic disk.

*** mass storage file**

A collection of records that is stored in a mass storage medium.

*** megabyte (MB)**

One megabyte equals 1,048,576 bytes.

*** merge file**

A collection of records to be merged by a MERGE statement. The merge file is created and can be used only by the merge function.

message-processing program (MPP)

An IMS application program that is driven by transactions and has access to online IMS databases and message queues.

message queue

The data set on which messages are queued before being processed by an application program or sent to a terminal.

method

Procedural code that defines an operation

supported by an object and that is executed by an INVOKE statement on that object.

*** method definition**

The COBOL source code that defines a method.

*** method identification entry**

An entry in the METHOD-ID paragraph of the IDENTIFICATION DIVISION; this entry contains a clause that specifies the method-name.

method invocation

A communication from one object to another that requests the receiving object to execute a method.

method-name

The name of an object-oriented operation. When used to invoke the method, the name can be an alphanumeric or national literal or a category alphanumeric or category national data item. When used in the METHOD-ID paragraph to define the method, the name must be an alphanumeric or national literal.

*** mnemonic-name**

A user-defined word that is associated in the ENVIRONMENT DIVISION with a specified implementor-name.

module definition file

A file that describes the code segments within a program object.

MPP See *message-processing program (MPP)*.

multitasking

A mode of operation that provides for the concurrent, or interleaved, execution of two or more tasks.

multithreading

Concurrent operation of more than one path of execution within a computer. Synonymous with *multiprocessing*.

N

name A word (composed of not more than 30 characters) that defines a COBOL operand.

namespace

See *XML namespace*.

national character

(1) A UTF-16 character in a USAGE

NATIONAL data item or national literal. (2)
Any character represented in UTF-16.

national character position

See *character position*.

national data item

A data item of category national, national-edited, or numeric-edited of USAGE NATIONAL.

national decimal data item

An external decimal data item that is described implicitly or explicitly as USAGE NATIONAL and that contains a valid combination of PICTURE symbols 9, S, P, and V.

national-edited data item

A data item that is described by a PICTURE character string that contains at least one instance of the symbol N and at least one of the simple insertion symbols B, 0, or /. A national-edited data item has USAGE NATIONAL.

national floating-point data item

An external floating-point data item that is described implicitly or explicitly as USAGE NATIONAL and that has a PICTURE character string that describes a floating-point data item.

national group item

A group item that is explicitly or implicitly described with a GROUP-USAGE NATIONAL clause. A national group item is processed as though it were defined as an elementary data item of category national for operations such as INSPECT, STRING, and UNSTRING. This processing ensures correct padding and truncation of national characters, as contrasted with defining USAGE NATIONAL data items within an alphanumeric group item. For operations that require processing of the elementary items within a group, such as MOVE CORRESPONDING, ADD CORRESPONDING, and INITIALIZE, a national group is processed using group semantics.

*** native character set**

The implementor-defined character set associated with the computer specified in the OBJECT-COMPUTER paragraph.

*** native collating sequence**

The implementor-defined collating

sequence associated with the computer specified in the OBJECT-COMPUTER paragraph.

native method

A Java method with an implementation that is written in another programming language, such as COBOL.

*** negated combined condition**

The NOT logical operator immediately followed by a parenthesized combined condition. See also *condition* and *combined condition*.

*** negated simple condition**

The NOT logical operator immediately followed by a simple condition. See also *condition* and *simple condition*.

nested program

A program that is directly contained within another program.

*** next executable sentence**

The next sentence to which control will be transferred after execution of the current statement is complete.

*** next executable statement**

The next statement to which control will be transferred after execution of the current statement is complete.

*** next record**

The record that logically follows the current record of a file.

*** noncontiguous items**

Elementary data items in the WORKING-STORAGE SECTION and LINKAGE SECTION that bear no hierarchic relationship to other data items.

null

A figurative constant that is used to assign, to pointer data items, the value of an address that is not valid. NULLS can be used wherever NULL can be used.

*** numeric character**

A character that belongs to the following set of digits: 0, 1, 2, 3, 4, 5, 6, 7, 8, 9.

numeric data item

(1) A data item whose description restricts its content to a value represented by characters chosen from the digits 0 through 9. If signed, the item can also contain a +, -, or other representation of an operational sign. (2) A data item of category numeric, internal floating-point,

or external floating-point. A numeric data item can have USAGE DISPLAY, NATIONAL, PACKED-DECIMAL, BINARY, COMP, COMP-1, COMP-2, COMP-3, COMP-4, or COMP-5.

numeric-edited data item

A data item that contains numeric data in a form suitable for use in printed output. The data item can consist of external decimal digits from 0 through 9, the decimal separator, commas, the currency sign, sign control characters, and other editing characters. A numeric-edited item can be represented in either USAGE DISPLAY or USAGE NATIONAL.

*** numeric function**

A function whose class and category are numeric but that for some possible evaluation does not satisfy the requirements of integer functions.

*** numeric literal**

A literal composed of one or more numeric characters that can contain a decimal point or an algebraic sign, or both. The decimal point must not be the rightmost character. The algebraic sign, if present, must be the leftmost character.

O

object

An entity that has state (its data values) and operations (its methods). An object is a way to encapsulate state and behavior. Each object in the class is said to be an instance of the class.

object code

Output from a compiler or assembler that is itself executable machine code or is suitable for processing to produce executable machine code.

*** OBJECT-COMPUTER**

The name of an ENVIRONMENT DIVISION paragraph in which the computer environment, where the object program is run, is described.

*** object computer entry**

An entry in the OBJECT-COMPUTER paragraph of the ENVIRONMENT DIVISION; this entry contains clauses that describe the computer environment in which the object program is to be executed.

object deck

A portion of an object program suitable as

input to a linkage-editor. Synonymous with *object module* and *text deck*.

object instance

See *object*.

object module

Synonym for *object deck* or *text deck*.

*** object of entry**

A set of operands and reserved words, within a DATA DIVISION entry of a COBOL program, that immediately follows the subject of the entry.

object-oriented programming

A programming approach based on the concepts of encapsulation and inheritance. Unlike procedural programming techniques, object-oriented programming concentrates on the data objects that comprise the problem and how they are manipulated, not on how something is accomplished.

object program

A set or group of executable machine-language instructions and other material designed to interact with data to provide problem solutions. In this context, an object program is generally the machine language result of the operation of a COBOL compiler on a source program or class definition. Where there is no danger of ambiguity, the word *program* can be used in place of *object program*.

object reference

A value that identifies an instance of a class. If the class is not specified, the object reference is universal and can apply to instances of any class.

*** object time**

The time at which an object program is executed. Synonymous with *run time*.

*** obsolete element**

A COBOL language element in the 85 COBOL Standard that was deleted from the 2002 COBOL Standard.

ODO object

In the example below, X is the object of the OCCURS DEPENDING ON clause (ODO object).

```

WORKING-STORAGE SECTION
01 TABLE-1.
   05 X                PICS9.
   05 Y OCCURS 3 TIMES
       DEPENDING ON X  PIC X.

```

The value of the ODO object determines how many of the ODO subject appear in the table.

ODO subject

In the example above, Y is the subject of the OCCURS DEPENDING ON clause (ODO subject). The number of Y ODO subjects that appear in the table depends on the value of X.

* open mode

The state of a file after execution of an OPEN statement for that file and before the execution of a CLOSE statement without the REEL or UNIT phrase for that file. The particular open mode is specified in the OPEN statement as either INPUT, OUTPUT, I-0, or EXTEND.

* operand

(1) The general definition of operand is "the component that is operated upon."
 (2) For the purposes of this document, any lowercase word (or words) that appears in a statement or entry format can be considered to be an operand and, as such, is an implied reference to the data indicated by the operand.

operation

A service that can be requested of an object.

* operational sign

An algebraic sign that is associated with a numeric data item or a numeric literal, to indicate whether its value is positive or negative.

optional file

A file that is declared as being not necessarily available each time the object program is run.

* optional word

A reserved word that is included in a specific format only to improve the readability of the language. Its presence is optional to the user when the format in which the word appears is used in a source unit.

* output file

A file that is opened in either output mode or extend mode.

* output mode

The state of a file after execution of an OPEN statement, with the OUTPUT or EXTEND phrase specified, for that file and before the execution of a CLOSE statement without the REEL or UNIT phrase for that file.

* output procedure

A set of statements to which control is given during execution of a format 1 SORT statement after the sort function is completed, or during execution of a MERGE statement after the merge function reaches a point at which it can select the next record in merged order when requested.

overflow condition

A condition that occurs when a portion of the result of an operation exceeds the capacity of the intended unit of storage.

overload

To define a method with the same name as another method that is available in the same class, but with a different signature. See also *signature*.

override

To redefine an instance method (inherited from a parent class) in a subclass.

P

package

A group of related Java classes, which can be imported individually or as a whole.

packed-decimal data item

See *internal decimal data item*.

padding character

An alphanumeric or national character that is used to fill the unused character positions in a physical record.

page

A vertical division of output data that represents a physical separation of the data. The separation is based on internal logical requirements or external characteristics of the output medium or both.

* page body

That part of the logical page in which lines can be written or spaced or both.

*** paragraph**

In the PROCEDURE DIVISION, a paragraph-name followed by a separator period and by zero, one, or more sentences. In the IDENTIFICATION DIVISION and ENVIRONMENT DIVISION, a paragraph header followed by zero, one, or more entries.

*** paragraph header**

A reserved word, followed by the separator period, that indicates the beginning of a paragraph in the IDENTIFICATION DIVISION and ENVIRONMENT DIVISION. The permissible paragraph headers in the IDENTIFICATION DIVISION are:

PROGRAM-ID. (Program IDENTIFICATION DIVISION)
CLASS-ID. (Class IDENTIFICATION DIVISION)
METHOD-ID. (Method IDENTIFICATION DIVISION)
AUTHOR.
INSTALLATION.
DATE-WRITTEN.
DATE-COMPILED.
SECURITY.

The permissible paragraph headers in the ENVIRONMENT DIVISION are:

SOURCE-COMPUTER.
OBJECT-COMPUTER.
SPECIAL-NAMES.
REPOSITORY. (Program or Class CONFIGURATION SECTION)
FILE-CONTROL.
I-O-CONTROL.

*** paragraph-name**

A user-defined word that identifies and begins a paragraph in the PROCEDURE DIVISION.

parameter

(1) Data passed between a calling program and a called program. (2) A data element in the USING phrase of a method invocation. Arguments provide additional information that the invoked method can use to perform the requested operation.

Persistent Reusable JVM

A JVM that can be serially reused for transaction processing by resetting the JVM between transactions. The reset phase restores the JVM to a known initialization state.

*** phrase**

An ordered set of one or more consecutive COBOL character strings that

form a portion of a COBOL procedural statement or of a COBOL clause.

*** physical record**

See *block*.

pointer data item

A data item in which address values can be stored. Data items are explicitly defined as pointers with the USAGE IS POINTER clause. ADDRESS OF special registers are implicitly defined as pointer data items. Pointer data items can be compared for equality or moved to other pointer data items.

port

(1) To modify a computer program to enable it to run on a different platform. (2) In the Internet suite of protocols, a specific logical connector between the Transmission Control Protocol (TCP) or the User Datagram Protocol (UDP) and a higher-level protocol or application. A port is identified by a port number.

portability

The ability to transfer an application program from one application platform to another with relatively few changes to the source program.

preinitialization

The initialization of the COBOL runtime environment in preparation for multiple calls from programs, especially non-COBOL programs. The environment is not terminated until an explicit termination.

*** prime record key**

A key whose contents uniquely identify a record within an indexed file.

*** priority-number**

A user-defined word that classifies sections in the PROCEDURE DIVISION for purposes of segmentation. Segment numbers can contain only the characters 0 through 9. A segment number can be expressed as either one or two digits.

private

As applied to factory data or instance data, accessible only by methods of the class that defines the data.

*** procedure**

A paragraph or group of logically successive paragraphs, or a section or

group of logically successive sections, within the PROCEDURE DIVISION.

*** procedure branching statement**

A statement that causes the explicit transfer of control to a statement other than the next executable statement in the sequence in which the statements are written in the source code. The procedure branching statements are: ALTER, CALL, EXIT, EXIT PROGRAM, GO TO, MERGE (with the OUTPUT PROCEDURE phrase), PERFORM and SORT (with the INPUT PROCEDURE or OUTPUT PROCEDURE phrase), XML PARSE.

PROCEDURE DIVISION

The COBOL division that contains instructions for solving a problem.

procedure integration

One of the functions of the COBOL optimizer is to simplify calls to performed procedures or contained programs.

PERFORM procedure integration is the process whereby a PERFORM statement is replaced by its performed procedures. Contained program procedure integration is the process where a call to a contained program is replaced by the program code.

*** procedure-name**

A user-defined word that is used to name a paragraph or section in the PROCEDURE DIVISION. It consists of a paragraph-name (which can be qualified) or a section-name.

procedure-pointer data item

A data item in which a pointer to an entry point can be stored. A data item defined with the USAGE IS PROCEDURE-POINTER clause contains the address of a procedure entry point. Typically used to communicate with COBOL and Language Environment programs.

process

The course of events that occurs during the execution of all or part of a program. Multiple processes can run concurrently, and programs that run within a process can share resources.

program

(1) A sequence of instructions suitable for processing by a computer. Processing may include the use of a compiler to prepare the program for execution, as well as a

runtime environment to execute it. (2) A logical assembly of one or more interrelated modules. Multiple copies of the same program can be run in different processes.

*** program identification entry**

In the PROGRAM-ID paragraph of the IDENTIFICATION DIVISION, an entry that contains clauses that specify the program-name and assign selected program attributes to the program.

program-name

In the IDENTIFICATION DIVISION and the end program marker, a user-defined word or alphanumeric literal that identifies a COBOL source program.

project

The complete set of data and actions that are required to build a target, such as a dynamic link library (DLL) or other executable (EXE).

*** pseudo-text**

A sequence of text words, comment lines, or the separator space in a source program or COBOL library bounded by, but not including, pseudo-text delimiters.

*** pseudo-text delimiter**

Two contiguous equal sign characters (==) used to delimit pseudo-text.

*** punctuation character**

A character that belongs to the following set:

Character	Meaning
,	Comma
;	Semicolon
:	Colon
.	Period (full stop)
"	Quotation mark
(Left parenthesis
)	Right parenthesis
	Space
=	Equal sign

Q

QSAM (Queued Sequential Access Method)

An extended version of the basic sequential access method (BSAM). When this method is used, a queue is formed of input data blocks that are awaiting processing or of output data blocks that

have been processed and are awaiting transfer to auxiliary storage or to an output device.

*** qualified data-name**

An identifier that is composed of a data-name followed by one or more sets of either of the connectives OF and IN followed by a data-name qualifier.

*** qualifier**

(1) A data-name or a name associated with a level indicator that is used in a reference either together with another data-name (which is the name of an item that is subordinate to the qualifier) or together with a condition-name. (2) A section-name that is used in a reference together with a paragraph-name specified in that section. (3) A library-name that is used in a reference together with a text-name associated with that library.

R

*** random access**

An access mode in which the program-specified value of a key data item identifies the logical record that is obtained from, deleted from, or placed into a relative or indexed file.

*** record**

See *logical record*.

*** record area**

A storage area allocated for the purpose of processing the record described in a record description entry in the FILE SECTION of the DATA DIVISION. In the FILE SECTION, the current number of character positions in the record area is determined by the explicit or implicit RECORD clause.

*** record description**

See *record description entry*.

*** record description entry**

The total set of data description entries associated with a particular record. Synonymous with *record description*.

record key

A key whose contents identify a record within an indexed file.

*** record-name**

A user-defined word that names a record described in a record description entry in the DATA DIVISION of a COBOL program.

*** record number**

The ordinal number of a record in the file whose organization is sequential.

recording mode

The format of the logical records in a file. Recording mode can be F (fixed length), V (variable length), S (spanned), or U (undefined).

recursion

A program calling itself or being directly or indirectly called by one of its called programs.

recursively capable

A program is recursively capable (can be called recursively) if the RECURSIVE attribute is on the PROGRAM-ID statement.

reel

A discrete portion of a storage medium, the dimensions of which are determined by each implementor that contains part of a file, all of a file, or any number of files. Synonymous with *unit* and *volume*.

reentrant

The attribute of a program or routine that lets more than one user share a single copy of a program object.

*** reference format**

A format that provides a standard method for describing COBOL source programs.

reference modification

A method of defining a new category alphanumeric, category DBCS, or category national data item by specifying the leftmost character and length relative to the leftmost character position of a USAGE DISPLAY, DISPLAY-1, or NATIONAL data item.

*** reference-modifier**

A syntactically correct combination of character strings and separators that defines a unique data item. It includes a delimiting left parenthesis separator, the leftmost character position, a colon separator, optionally a length, and a delimiting right parenthesis separator.

*** relation**

See *relational operator* or *relation condition*.

*** relation character**

A character that belongs to the following set:

Character	Meaning
>	Greater than
<	Less than
=	Equal to

*** relation condition**

The proposition (for which a truth value can be determined) that the value of an arithmetic expression, data item, alphanumeric literal, or index-name has a specific relationship to the value of another arithmetic expression, data item, alphanumeric literal, or index name. See also *relational operator*.

*** relational operator**

A reserved word, a relation character, a group of consecutive reserved words, or a group of consecutive reserved words and relation characters used in the construction of a relation condition. The permissible operators and their meanings are:

Character	Meaning
IS GREATER THAN	Greater than
IS >	Greater than
IS NOT GREATER THAN	Not greater than
IS NOT >	Not greater than
IS LESS THAN	Less than
IS <	Less than
IS NOT LESS THAN	Not less than
IS NOT <	Not less than
IS EQUAL TO	Equal to
IS =	Equal to
IS NOT EQUAL TO	Not equal to
IS NOT =	Not equal to
IS GREATER THAN OR EQUAL TO	Greater than or equal to
IS >=	Greater than or equal to
IS LESS THAN OR EQUAL TO	Less than or equal to
IS <=	Less than or equal to

*** relative file**

A file with relative organization.

*** relative key**

A key whose contents identify a logical record in a relative file.

*** relative organization**

The permanent logical file structure in which each record is uniquely identified

by an integer value greater than zero, which specifies the logical ordinal position of the record in the file.

*** relative record number**

The ordinal number of a record in a file whose organization is relative. This number is treated as a numeric literal that is an integer.

*** reserved word**

A COBOL word that is specified in the list of words that can be used in a COBOL source program, but that must not appear in the program as a user-defined word or system-name.

*** resource**

A facility or service, controlled by the operating system, that an executing program can use.

*** resultant identifier**

A user-defined data item that is to contain the result of an arithmetic operation.

reusable environment

A reusable environment is created when you establish an assembler program as the main program by using either the old COBOL interfaces for preinitialization (RTEREUS runtime option), or the Language Environment interface, CEEPIPL.

routine

A set of statements in a COBOL program that causes the computer to perform an operation or series of related operations. In Language Environment, refers to either a procedure, function, or subroutine.

*** routine-name**

A user-defined word that identifies a procedure written in a language other than COBOL.

*** run time**

The time at which an object program is executed. Synonymous with *object time*.

runtime environment

The environment in which a COBOL program executes.

*** run unit**

A stand-alone object program, or several object programs, that interact by means of COBOL CALL or INVOKE statements and function at run time as an entity.

S

SBCS See *single-byte character set (SBCS)*.

scope terminator

A COBOL reserved word that marks the end of certain PROCEDURE DIVISION statements. It can be either explicit (END-ADD, for example) or implicit (separator period).

* **section**

A set of zero, one, or more paragraphs or entities, called a section body, the first of which is preceded by a section header. Each section consists of the section header and the related section body.

* **section header**

A combination of words followed by a separator period that indicates the beginning of a section in any of these divisions: ENVIRONMENT, DATA, or PROCEDURE. In the ENVIRONMENT DIVISION and DATA DIVISION, a section header is composed of reserved words followed by a separator period. The permissible section headers in the ENVIRONMENT DIVISION are:

CONFIGURATION SECTION.
INPUT-OUTPUT SECTION.

The permissible section headers in the DATA DIVISION are:

FILE SECTION.
WORKING-STORAGE SECTION.
LOCAL-STORAGE SECTION.
LINKAGE SECTION.

In the PROCEDURE DIVISION, a section header is composed of a section-name, followed by the reserved word SECTION, followed by a separator period.

* **section-name**

A user-defined word that names a section in the PROCEDURE DIVISION.

selection structure

A program processing logic in which one or another series of statements is executed, depending on whether a condition is true or false.

* **sentence**

A sequence of one or more statements, the last of which is terminated by a separator period.

* **separately compiled program**

A program that, together with its contained programs, is compiled separately from all other programs.

* **separator**

A character or two or more contiguous characters used to delimit character strings.

* **separator comma**

A comma (,) followed by a space used to delimit character strings.

* **separator period**

A period (.) followed by a space used to delimit character strings.

* **separator semicolon**

A semicolon (;) followed by a space used to delimit character strings.

sequence structure

A program processing logic in which a series of statements is executed in sequential order.

* **sequential access**

An access mode in which logical records are obtained from or placed into a file in a consecutive predecessor-to-successor logical record sequence determined by the order of records in the file.

* **sequential file**

A file with sequential organization.

* **sequential organization**

The permanent logical file structure in which a record is identified by a predecessor-successor relationship established when the record is placed into the file.

serial search

A search in which the members of a set are consecutively examined, beginning with the first member and ending with the last.

session bean

In EJB, an enterprise bean that is created by a client and that usually exists only for the duration of a single client/server session. (Oracle)

77-level-description-entry

A data description entry that describes a noncontiguous data item that has level-number 77.

*** sign condition**

The proposition (for which a truth value can be determined) that the algebraic value of a data item or an arithmetic expression is either less than, greater than, or equal to zero.

signature

(1) The name of an operation and its parameters. (2) The name of a method and the number and types of its formal parameters.

*** simple condition**

Any single condition chosen from this set:

- Relation condition
- Class condition
- Condition-name condition
- Switch-status condition
- Sign condition

See also *condition* and *negated simple condition*.

single-byte character set (SBCS)

A set of characters in which each character is represented by a single byte. See also *ASCII* and *EBCDIC (Extended Binary-Coded Decimal Interchange Code)*.

slack bytes

Bytes inserted between data items or records to ensure correct alignment of some numeric items. Slack bytes contain no meaningful data. In some cases, they are inserted by the compiler; in others, it is the responsibility of the programmer to insert them. The *SYNCHRONIZED* clause instructs the compiler to insert slack bytes when they are needed for proper alignment. Slack bytes between records are inserted by the programmer.

*** sort file**

A collection of records to be sorted by a format 1 *SORT* statement. The sort file is created and can be used by the sort function only.

*** sort-merge file description entry**

An entry in the *FILE SECTION* of the *DATA DIVISION* that is composed of the level indicator *SD*, followed by a file-name, and then followed by a set of file clauses as required.

*** SOURCE-COMPUTER**

The name of an *ENVIRONMENT DIVISION* paragraph in which the computer

environment, where the source program is compiled, is described.

*** source computer entry**

An entry in the *SOURCE-COMPUTER* paragraph of the *ENVIRONMENT DIVISION*; this entry contains clauses that describe the computer environment in which the source program is to be compiled.

*** source item**

An identifier designated by a *SOURCE* clause that provides the value of a printable item.

source program

Although a source program can be represented by other forms and symbols, in this document the term always refers to a syntactically correct set of *COBOL* statements. A *COBOL* source program commences with the *IDENTIFICATION DIVISION* or a *COPY* statement and terminates with the end program marker, if specified, or with the absence of additional source program lines.

source unit

A unit of *COBOL* source code that can be separately compiled: a program or a class definition. Also known as a *compilation unit*.

special character

A character that belongs to the following set:

Character	Meaning
+	Plus sign
-	Minus sign (hyphen)
*	Asterisk
/	Slant (forward slash)
=	Equal sign
\$	Currency sign
,	Comma
;	Semicolon
.	Period (decimal point, full stop)
"	Quotation mark
'	Apostrophe
(Left parenthesis
)	Right parenthesis
>	Greater than
<	Less than
:	Colon
_	Underscore

SPECIAL-NAMES

The name of an *ENVIRONMENT DIVISION*

paragraph in which environment-names are related to user-specified mnemonic-names.

*** special names entry**

An entry in the SPECIAL-NAMES paragraph of the ENVIRONMENT DIVISION; this entry provides means for specifying the currency sign; choosing the decimal point; specifying symbolic characters; relating implementor-names to user-specified mnemonic-names; relating alphabet-names to character sets or collating sequences; and relating class-names to sets of characters.

*** special registers**

Certain compiler-generated storage areas whose primary use is to store information produced in conjunction with the use of a specific COBOL feature.

*** statement**

A syntactically valid combination of words, literals, and separators, beginning with a verb, written in a COBOL source program.

structured programming

A technique for organizing and coding a computer program in which the program comprises a hierarchy of segments, each segment having a single entry point and a single exit point. Control is passed downward through the structure without unconditional branches to higher levels of the hierarchy.

*** subclass**

A class that inherits from another class. When two classes in an inheritance relationship are considered together, the subclass is the inheritor or inheriting class; the superclass is the inheritee or inherited class.

*** subject of entry**

An operand or reserved word that appears immediately following the level indicator or the level-number in a DATA DIVISION entry.

*** subprogram**

See *called program*.

*** subscript**

An occurrence number that is represented by either an integer, a data-name optionally followed by an integer with the operator + or -, or an index-name

optionally followed by an integer with the operator + or -, that identifies a particular element in a table. A subscript can be the word ALL when the subscripted identifier is used as a function argument for a function allowing a variable number of arguments.

*** subscripted data-name**

An identifier that is composed of a data-name followed by one or more subscripts enclosed in parentheses.

substitution character

A character that is used in a conversion from a source code page to a target code page to represent a character that is not defined in the target code page.

*** superclass**

A class that is inherited by another class. See also *subclass*.

surrogate pair

In the UTF-16 format of Unicode, a pair of encoding units that together represents a single Unicode graphic character. The first unit of the pair is called a *high surrogate* and the second a *low surrogate*. The code value of a high surrogate is in the range X'D800' through X'DBFF'. The code value of a low surrogate is in the range X'DC00' through X'DFFF'. Surrogate pairs provide for more characters than the 65,536 characters that fit in the Unicode 16-bit coded character set.

switch-status condition

The proposition (for which a truth value can be determined) that an UPSI switch, capable of being set to an on or off status, has been set to a specific status.

*** symbolic-character**

A user-defined word that specifies a user-defined figurative constant.

syntax (1) The relationship among characters or groups of characters, independent of their meanings or the manner of their interpretation and use. (2) The structure of expressions in a language. (3) The rules governing the structure of a language. (4) The relationship among symbols. (5) The rules for the construction of a statement.

*** system-name**

A COBOL word that is used to communicate with the operating environment.

T

* **table**

A set of logically consecutive items of data that are defined in the DATA DIVISION by means of the OCCURS clause.

* **table element**

A data item that belongs to the set of repeated items comprising a table.

text deck

Synonym for *object deck* or *object module*.

* **text-name**

A user-defined word that identifies library text.

* **text word**

A character or a sequence of contiguous characters between margin A and margin R in a COBOL library, source program, or pseudo-text that is any of the following characters:

- A separator, except for space; a pseudo-text delimiter; and the opening and closing delimiters for alphanumeric literals. The right parenthesis and left parenthesis characters, regardless of context within the library, source program, or pseudo-text, are always considered text words.
- A literal including, in the case of alphanumeric literals, the opening quotation mark and the closing quotation mark that bound the literal.
- Any other sequence of contiguous COBOL characters except comment lines and the word COPY bounded by separators that are neither a separator nor a literal.

thread

A stream of computer instructions (initiated by an application within a process) that is in control of a process.

token In the COBOL editor, a unit of meaning in a program. A token can contain data, a language keyword, an identifier, or other part of the language syntax.

top-down design

The design of a computer program using a hierarchic structure in which related functions are performed at each level of the structure.

top-down development

See *structured programming*.

trailer-label

- (1) A data-set label that follows the data records on a unit of recording medium.
- (2) Synonym for *end-of-file label*.

troubleshoot

To detect, locate, and eliminate problems in using computer software.

* **truth value**

The representation of the result of the evaluation of a condition in terms of one of two values: true or false.

typed object reference

A data-name that can refer only to an object of a specified class or any of its subclasses.

U

* **unary operator**

A plus (+) or a minus (-) sign that precedes a variable or a left parenthesis in an arithmetic expression and that has the effect of multiplying the expression by +1 or -1, respectively.

Unicode

A universal character encoding standard that supports the interchange, processing, and display of text that is written in any of the languages of the modern world. There are multiple encoding schemes to represent Unicode, including UTF-8, UTF-16, and UTF-32. Enterprise COBOL supports Unicode using UTF-16 in big-endian format as the representation for the national data type.

Uniform Resource Identifier (URI)

A sequence of characters that uniquely names a resource; in Enterprise COBOL, the identifier of a namespace. URI syntax is defined by the document *Uniform Resource Identifier (URI): Generic Syntax*.

unit A module of direct access, the dimensions of which are determined by IBM.

universal object reference

A data-name that can refer to an object of any class.

unrestricted storage

Storage below the 2 GB bar. It can be above or below the 16 MB line. If it is above the 16 MB line, it is addressable only in 31-bit mode.

*** unsuccessful execution**

The attempted execution of a statement that does not result in the execution of all the operations specified by that statement. The unsuccessful execution of a statement does not affect any data referenced by that statement, but can affect status indicators.

UPSI switch

A program switch that performs the functions of a hardware switch. Eight are provided: UPSI-0 through UPSI-7.

URI See *Uniform Resource Identifier (URI)*.

*** user-defined word**

A COBOL word that must be supplied by the user to satisfy the format of a clause or statement.

V

*** variable**

A data item whose value can be changed by execution of the object program. A variable used in an arithmetic expression must be a numeric elementary item.

variable-length item

A group item that contains a table described with the *DEPENDING* phrase of the *OCCURS* clause.

*** variable-length record**

A record associated with a file whose file description or sort-merge description entry permits records to contain a varying number of character positions.

*** variable-occurrence data item**

A variable-occurrence data item is a table element that is repeated a variable number of times. Such an item must contain an *OCCURS DEPENDING ON* clause in its data description entry or be subordinate to such an item.

*** variably located group**

A group item following, and not subordinate to, a variable-length table in the same record. The group item can be an alphanumeric group or a national group.

*** variably located item**

A data item following, and not subordinate to, a variable-length table in the same record.

*** verb**

A word that expresses an action to be taken by a COBOL compiler or object program.

volume

A module of external storage. For tape devices it is a reel; for direct-access devices it is a unit.

volume switch procedures

System-specific procedures that are executed automatically when the end of a unit or reel has been reached before end-of-file has been reached.

VSAM file system

A file system that supports COBOL sequential, relative, and indexed organizations.

W

web service

A modular application that performs specific tasks and is accessible through open protocols like HTTP and SOAP.

white space

Characters that introduce space into a document. They are:

- Space
- Horizontal tabulation
- Carriage return
- Line feed
- Next line

as named in the Unicode Standard.

*** word**

A character string of not more than 30 characters that forms a user-defined word, a system-name, a reserved word, or a function-name.

*** WORKING-STORAGE SECTION**

The section of the *DATA DIVISION* that describes *WORKING-STORAGE* data items, composed either of noncontiguous items or *WORKING-STORAGE* records or of both.

workstation

A generic term for computers, including personal computers, 3270 terminals, intelligent workstations, and UNIX terminals. Often a workstation is connected to a mainframe or to a network.

wrapper

An object that provides an interface between object-oriented code and procedure-oriented code. Using wrappers lets programs be reused and accessed by other systems.

X

x The symbol in a PICTURE clause that can hold any character in the character set of the computer.

XML Extensible Markup Language. A standard metalanguage for defining markup languages that was derived from and is a subset of SGML. XML omits the more complex and less-used parts of SGML and makes it much easier to write applications to handle document types, author and manage structured information, and transmit and share structured information across diverse computing systems. The use of XML does not require the robust applications and processing that is necessary for SGML. XML is developed under the auspices of the World Wide Web Consortium (W3C).

XML data

Data that is organized into a hierarchical structure with XML elements. The data definitions are defined in XML element type declarations.

XML declaration

XML text that specifies characteristics of the XML document such as the version of XML being used and the encoding of the document.

XML document

A data object that is well formed as defined by the W3C XML specification.

XML namespace

A mechanism, defined by the W3C XML Namespace specifications, that limits the scope of a collection of element names and attribute names. A uniquely chosen XML namespace ensures the unique identity of an element name or attribute name across multiple XML documents or multiple contexts within an XML document.

XML schema

A mechanism, defined by the W3C, for describing and constraining the structure

and content of XML documents. An XML schema, which is itself expressed in XML, effectively defines a class of XML documents of a given type, for example, purchase orders.

Z

z/OS UNIX file system

A collection of files and directories that are organized in a hierarchical structure and can be accessed by using z/OS UNIX.

zoned decimal data item

An external decimal data item that is described implicitly or explicitly as USAGE DISPLAY and that contains a valid combination of PICTURE symbols 9, S, P, and V. The content of a zoned decimal data item is represented in characters 0 through 9, optionally with a sign. If the PICTURE string specifies a sign and the SIGN IS SEPARATE clause is specified, the sign is represented as characters + or -. If SIGN IS SEPARATE is not specified, the sign is one hexadecimal digit that overlays the first 4 bits of the sign position (leading or trailing).

#

85 COBOL Standard

The COBOL language defined by the following standards:

- *ANSI INCITS 23-1985, Programming languages - COBOL, as amended by ANSI INCITS 23a-1989, Programming Languages - COBOL - Intrinsic Function Module for COBOL and ANSI INCITS 23b-1993, Programming Languages - Correction Amendment for COBOL*
- *ISO 1989:1985, Programming languages - COBOL, as amended by ISO/IEC 1989/AMD1:1992, Programming languages - COBOL: Intrinsic function module and ISO/IEC 1989/AMD2:1994, Programming languages - Correction and clarification amendment for COBOL*

2002 COBOL Standard

The COBOL language defined by the following standards:

- *INCITS/ISO/IEC 1989-2002, Information Technology - Programming Languages - COBOL*

- ISO/IEC 1989:2002, Information technology -- Programming languages -- COBOL

List of resources

Enterprise COBOL for z/OS COBOL for z/OS publications

You can find the following publications in the Enterprise COBOL for z/OS library:

- *Customization Guide*, SC14-7380
- *Language Reference*, SC14-7381
- *Programming Guide*, SC14-7382
- *Migration Guide*, GC14-7383
- *Program Directory*, GI11-9180
- *Licensed Program Specifications*, GI11-9181

Softcopy publications

The following collection kits contain Enterprise COBOL and other product publications. You can find them at <http://www-05.ibm.com/e-business/linkweb/publications/servlet/pbi.wss>.

- *z/OS Software Products Collection*
- *z/OS and Software Products DVD Collection*

Support

Performance Tuning, www.ibm.com/support/docview.wss?uid=swg27018287

If you have a problem using Enterprise COBOL for z/OS, see the following site that provides up-to-date support information:
https://www.ibm.com/support/home/product/B984385H82239E03/Enterprise_COBOL_for_z/OS.

Related publications

z/OS library publications

You can find the following publications in the z/OS Internet Library.

Run-Time Library Extensions

- *DWARF/ELF Extensions Library Reference*
- *Common Debug Architecture Library Reference*
- *Common Debug Architecture User's Guide*

z/Architecture

- *Principles of Operation*

z/OS DFSMS

- *Access Method Services for Catalogs*
- *Checkpoint/Restart*
- *Macro Instructions for Data Sets*
- *Using Data Sets*
- *Utilities*

z/OS DFSORT

- *Application Programming Guide*
- *Installation and Customization*

z/OS ISPF

- *Dialog Developer's Guide and Reference*
- *User's Guide Vol I*
- *User's Guide Vol II*

z/OS Language Environment

- *Concepts Guide*
- *Customization*
- *Debugging Guide*
- *Programming Guide*
- *Programming Reference*
- *Run-Time Messages*
- *Run-Time Application Migration Guide*
- *Language Environment Vendor Interfaces*
- *Writing Interlanguage Communication Applications*

z/OS MVS

- *JCL Reference*
- *JCL User's Guide*
- *Program Management: User's Guide and Reference*
- *System Commands*
- *z/OS Unicode Services User's Guide and Reference*
- *z/OS XML System Services User's Guide and Reference*

z/OS TSO/E

- *Command Reference*
- *Primer*
- *User's Guide*

z/OS UNIX System Services

- *Command Reference*

- *Programming: Assembler Callable Services Reference*
- *User's Guide*

z/OS XL C/C++

- *Programming Guide*
- *Run-Time Library Reference*

CICS Transaction Server for z/OS

You can find the following publications in the CICS Library:

- *Application Programming Guide*
- *Application Programming Reference*
- *Customization Guide*
- *External Interfaces Guide*

DB2 for z/OS

You can find the following publications in the DB2 Library:

- *Application Programming and SQL Guide*
- *Command Reference*
- *SQL Reference*

Debug Tool

You can find the following publications in the Debug Tool Library:

- *Reference and Messages*
- *User's Guide*

You can find the following publications by searching their publication numbers in the IBM Publications Center.

IMS

- *Application Programming API Reference*, SC18-9699
- *Application Programming Guide*, SC18-9698

WebSphere Application Server for z/OS

- *Applications*, SA22-7959

Softcopy publications for z/OS

The following collection kit contains z/OS and related product publications:

- *z/OS CD Collection Kit*, SK3T-4269

Java

- *IBM SDK, Java Technology Edition*, developer.ibm.com/javasdk/documentation/
- *The Java 2 Enterprise Edition Developer's Guide*, download.oracle.com/javase/1.2.1/devguide/html/DevGuideTOC.html
- *Java 2 on z/OS*, www.ibm.com/servers/eserver/zseries/software/java/
- *The Java EE 5 Tutorial*, download.oracle.com/javase/5/tutorial/doc/
- *The Java Language Specification, Third Edition*, by Gosling et al., java.sun.com/docs/books/jls/
- *The Java Native Interface*, download.oracle.com/javase/1.5.0/docs/guide/jni/
- *JDK 5.0 Documentation*, download.oracle.com/javase/1.5.0/docs/

Unicode and character representation

- *Unicode*, www.unicode.org/
- *Character Data Representation Architecture Reference and Registry*, SC09-2190

XML

- *Extensible Markup Language (XML)*, www.w3.org/XML/
- *Namespaces in XML 1.0*, www.w3.org/TR/xml-names/
- *Namespaces in XML 1.1*, www.w3.org/TR/xml-names11/
- *XML specification*, www.w3.org/TR/xml/

Index

Special characters

`_BPX_SHAREAS` environment variable 467

`_CEE_ENVFILE` environment variable
description 465
indicating Java settings 297

`_CEE_RUNOPTS` environment variable
description 465
setting XPLINK 299
specifying runtime options 463

`_IGZ_SYSOUT` environment variable
setting 465
writing to stdout or stderr 36

`#` cob2 option for displaying compile and link steps 288

`-b` cob2 option
for creating DLLs 286
for passing information to the linker 287

`-c` cob2 option for compiling but not linking 287

`-comprc_ok` cob2 option for controlling compiler based on return code 287

`-e` cob2 option for specifying entry point 287

`-g` cob2 option equivalent to specifying TEST 288

`-I` cob2 option for searching copybooks 288

`-l` cob2 option for specifying archive library name 288

`-L` cob2 option for specifying archive library path 288

`-o` cob2 option for specifying output file 288

`-q` cob2 option for specifying compiler options 288

`-v` cob2 option for displaying and executing compile and link steps 288

`!` character, hexadecimal values 550

`.a` suffix with cob2 289

`.adt` file 305

`.adt` suffix with cob2 289

`.cbl` suffix with cob2 289

`.dek` suffix with cob2 289

`.lst` suffix with cob2 289

`.o` suffix with cob2 289

`.x` suffix with cob2 289

`*CBL` statement 381

`*CONTROL` statement 381

`[` character, hexadecimal values 550

`]` character, hexadecimal values 550

`|` character, hexadecimal values 550

`#` character, hexadecimal values 550

Numerics

16 MB line
CICS programs 430
IMS programs 430

16 MB line (*continued*)
performance options 669

24-bit addressing mode 39

31-bit addressing mode 39
dynamic call 479

64-bit addressing
no support 39

85 COBOL Standard
checkpoints 652
required compiler options 304
required runtime options 304

A

`a` suffix with cob2 289

`a.out` file from cob2 289

abends, compile-time 322

ACCEPT statement
assigning input 35
reading from stdin 35
under CICS 431

access method services
build alternate indexes in advance 209
defining VSAM data sets to z/OS 203
loading a VSAM data set 197

accessibility
of Enterprise COBOL xx
of this information xxi
using z/OS xx

ADATA compiler option 305

adding records
to line-sequential files 217
to QSAM files 172
to VSAM files 199

ADDRESS OF special register
use in CALL statement 492

addresses
incrementing 497
NULL value 497
passing between programs 497
passing entry-point addresses 487

addressing mode, definition 39

ADEXIT suboption of EXIT option
processing of 717
syntax 325

ADMODE attribute
with multithreading 523

adt suffix with cob2 289

ADV compiler option 306

AFP compiler option 307
performance considerations 669

AIXBLD runtime option
effect on performance 673

ALL subscript
examples 89
processing table elements iteratively 89
table elements as function arguments 58

ALL31 runtime option
multioption interaction 40
OFF for AMODE switching 479

ALLOCATE command (TSO)
compiler data sets 262
with z/OS UNIX files 263

allocation of files
description 157
line-sequential 215
QSAM 174
under TSO 262
VSAM 206

ALPHABET clause, establishing collating sequence with 6

alphabetic data
comparing to national 149
MOVE statement with 32

alphanumeric comparison 98

alphanumeric data
comparing
effect of ZWB 379
to national 149
converting
to DBCS with IGZCA2D 695
to national with MOVE 138
to national with NATIONAL-OF 139
MOVE statement with 32
with double-byte characters 695

alphanumeric group item
a group without GROUP-USAGE NATIONAL 25
definition 24

alphanumeric literals
conversion of mixed DBCS/EBCDIC 695
description 25
with DBCS content 151
with double-byte characters 695

alphanumeric-edited data
initializing
example 29
using INITIALIZE 74
MOVE statement with 32

alternate collating sequence
choosing 229
example 7

alternate entry point, calling 489

alternate index
creating 204
example of 205
password for 202
path 204, 205
performance considerations 210
using 189

ALTERNATE RECORD KEY clause
identify alternate indexes 205
identifying alternate keys in KSDS files 189

alternate reserved-word table
CICS 437

- alternate reserved-word table (*continued*)
 - specifying 372
 - AMODE
 - and DLLs 512
 - description 39
 - of EXIT modules 712
 - switching
 - ALL31(OFF) 479
 - examples 479
 - overview 479
 - AMP parameter 206
 - ANNUITY intrinsic function 62
 - APIs, UNIX and POSIX
 - calling 466
 - APOST compiler option 352
 - APPLY WRITE-ONLY clause 10
 - ARCH compiler option 307
 - performance considerations 669
 - arguments
 - describing in calling program 493
 - from main program
 - accessing in z/OS 505
 - accessing in z/OS UNIX 468
 - passing BY VALUE 493
 - specifying OMITTED 495
 - testing for OMITTED arguments 495
 - ARITH compiler option
 - description 309
 - performance considerations 669
 - arithmetic
 - COMPUTE statement simpler to code 56
 - error handling 240
 - with intrinsic functions 57
 - arithmetic comparisons 63
 - arithmetic evaluation
 - conversions and precision 52
 - data format conversion 52
 - examples 63, 64
 - fixed-point contrasted with floating-point 63
 - intermediate results 685
 - performance tips 663
 - precedence 57, 687
 - precision 685
 - arithmetic expression
 - as reference modifier 114
 - description of 57
 - in nonarithmetic statement 693
 - in parentheses 57
 - arrays
 - COBOL 39
 - Java
 - declaring 639
 - manipulating 640
 - ASCII
 - alphabet, QSAM 182
 - code pages supported in XML documents 546
 - converting to EBCDIC 119
 - job control language (JCL) 183
 - record formats, QSAM 183
 - tape files, QSAM 182
 - ASCII files
 - CODE-SET clause 14
 - OPTCD= parameter in DCB 14
 - assembler
 - expansion of PROCEDURE DIVISION 405
 - programs
 - calls from (in CICS) 431
 - compiling from 265
 - listing of 334, 667
 - with multithreading 523
 - ASSIGN clause
 - corresponds to ddname 8
 - QSAM files 160
 - assigning values 27
 - assistive technologies xxi
 - associated-data file, creating 271
 - asynchronous signals with multithreading 523
 - AT END (end-of-file) phrase 244
 - ATTACH macro 265
 - attribute methods 603
 - automatic restart 655
 - available files
 - QSAM 171
 - VSAM 202
 - AWO compiler option
 - APPLY-WRITE ONLY clause
 - performance 10
 - description 310
 - performance considerations 669
- ## B
- Base class
 - equating to java.lang.Object 595
 - using for java.lang.Object 594
 - base cluster name 205
 - base locator 401, 402
 - base locator table 419
 - basis libraries 270
 - BASIS statement 381
 - batch compilation
 - description 275
 - LANGUAGE option
 - example 279
 - precedence of options
 - example 278
 - overview 277
 - Bibliography 863
 - big-endian, converting to little-endian 130
 - binary data 341
 - binary data item
 - general description 48
 - intermediate results 690
 - synonyms 47
 - using efficiently 48, 663
 - binary search
 - description 87
 - example 88
 - binder
 - c89 command 285
 - options needed for DLLs 509
 - recommended for DLLs 509
 - binding OO applications
 - example 298
 - using JCL or TSO/E 296
 - BLANK WHEN ZERO clause
 - coded for numeric data 131
 - BLANK WHEN ZERO clause (*continued*)
 - example with numeric-edited data 45
 - BLOCK CONTAINS clause
 - FILE SECTION entry 13
 - no meaning for VSAM files 192
 - QSAM files 161, 168, 310
 - block size
 - ASCII files 183
 - compiler data sets 268
 - QSAM files 168, 310
 - fixed-length 161
 - record layout 163
 - using DCB 176
 - variable-length 162
 - system-determined
 - compiler data sets 268
 - QSAM files 168, 310
 - BLOCK0 compiler option
 - description 310
 - performance considerations 669
 - blocking factor, definition 161
 - blocking QSAM files
 - using BLOCK CONTAINS clause 168
 - using BLOCK0 310
 - blocking records 168
 - BPXBATCH utility
 - calling z/OS UNIX programs 464
 - running OO applications 296
 - branch, implicit 102
 - buffers
 - best use of 10
 - obtaining for QSAM 181
 - BUFSIZE compiler option 312
 - BY CONTENT 491
 - BY REFERENCE 491
 - BY VALUE
 - description 491
 - restrictions 493
 - valid data types 493
 - byte order mark not generated 577
 - byte-stream files
 - processing with QSAM 181
- ## C
- C/C++ programs
 - with COBOL DLLs 515
 - with multithreading 523
 - c89 command for link step 285
 - CALL command (TSO) 262
 - CALL identifier
 - always dynamic 479
 - dynamic calls 477
 - making from DLLs 510
 - with NODLL 477
 - with NODYNAM 481
 - CALL literal
 - dynamic calls 477
 - static calls 476
 - with DYNAM 477
 - with NODLL 476, 477
 - with NODYNAM 476, 481
 - CALL statement
 - AMODE processing 479
 - BY CONTENT 491
 - BY REFERENCE 491

- CALL statement (*continued*)
 - BY VALUE
 - description 491
 - restrictions 493
 - CICS restrictions 431
 - effect of EXIT option on registers 712
 - exception condition 250
 - for error handling 250
 - function-pointer 489
 - handling of program-name in 349
 - Language Environment callable services 679
 - overflow condition 250
 - RETURNING 501
 - to alternate entry points 489
 - USING 493
 - with CANCEL 478
 - with DYNAM 323
 - with ON EXCEPTION 250
 - with ON OVERFLOW 20, 250
- calls
 - 31-bit addressing mode 479
 - AMODE switching for 24-bit programs 479
 - between COBOL and non-COBOL programs 473
 - between COBOL programs 473, 475
 - CICS restrictions 431
 - dynamic
 - example 482
 - making 477
 - performance 481
 - restrictions 477
 - with static calls 481
 - exception condition 250
 - interlanguage 473
 - LINKAGE SECTION 495
 - OMITTED arguments 495
 - overflow condition 250
 - passing arguments 493
 - passing data 491
 - receiving parameters 494
 - recursive 487
 - static
 - example 482
 - making 476
 - performance 481
 - with dynamic calls 481
 - to and from object-oriented programs 487
 - to JNI services 633
 - to Language Environment callable services 679
- CANCEL statement
 - cannot use with DLL linkage 512
 - for subprograms 478
 - handling of program-name in 349
 - with dynamic CALL 478
- case structure, EVALUATE statement for 95
- cataloged procedure
 - JCL for compiling 256
 - to compile (IGYWC) 257
 - to compile and link-edit (IGYWCL) 258
 - to compile, link-edit, run (IGYWCLG) 259
- CBL statement
 - overview 381
 - specifying compiler options 273
- cbl suffix with cob2 289
- CBLPSHPOP runtime option 438
- CBLQDA runtime option 171
- CCSID
 - conflict in XML documents 555
 - definition 129
 - EBCDIC multibyte CCSIDs 315
 - in PARSE statement 530
 - of DB2 string data 447
 - of XML documents 546
 - of XML documents to be parsed 530
 - specifying with CODEPAGE option 313
- chained-list processing
 - example 498
 - overview 497
- changing
 - characters to numbers 117
 - file-name 9
 - title on source listing 5
- CHAR intrinsic function, example 119
- character set, definition 129
- CHECK runtime option
 - performance considerations 671
- checking for valid data
 - conditional expressions 98
- checkpoint
 - 85 COBOL Standard 652
 - designing 652
 - example of JCL for restart 657
 - messages generated during 654
 - methods 651
 - multiple 652, 654
 - overview 651
 - record data set 653
 - restart during DFSORT 236
 - restrictions during sort 652
 - setting 651
 - single 652
 - disk 654
 - tape 653
 - testing 653
- Chinese GB 18030 data
 - processing 146
- CHKPT keyword 236
- CICS
 - alternate reserved-word table 437
 - calling nested programs 432
 - CICS HANDLE 438
 - example 439
 - LABEL value 438
 - coding programs to run under
 - calls 431
 - DISPLAY statement 430
 - I/O 430
 - overview 429
 - restrictions 429
 - SORT statement 438
 - command-level interface 429
 - commands and the PROCEDURE DIVISION 429
 - compiling with CICS option 433
 - developing programs for 429
- CICS (*continued*)
 - DFHCOMMAREA parameter
 - calling nested programs 432
 - calling separately compiled programs 431
 - DFHEIBLK parameter
 - calling nested programs 432
 - calling separately compiled programs 431
 - ECI calls and RETURN-CODE special register 433
 - EXIT compiler option and 728
 - in a multithreaded environment 523
 - integrated translator
 - advantages 435
 - calling nested programs 432
 - compiler options for 434
 - overview 435
 - interlanguage communication
 - under 432
 - macro-level interface 429
 - NODYNAM compiler option 432
 - performance
 - overview 661
 - performance considerations 439, 672
 - restrictions
 - 16 MB line 430
 - files 5
 - OO programs 429, 589
 - OUTDD compiler option 348
 - parsing with validation using FILE 541
 - separate translator 435
 - sorting 237
 - separate translator
 - calling nested programs 433
 - compiler options for 436
 - restrictions 435
 - using 436
 - sorting under
 - change reserved-word table 438
 - overview 237
 - restrictions 237
 - system date, getting 431
- CICS compiler option
 - description 312
 - enables integrated translator 435
 - multioption interaction 305
 - specifying suboptions 313, 435
 - using 433
- CISZ (control interval size), performance considerations 210, 673
- CKPT keyword 236
- class
 - defining 592
 - definition of 589
 - factory data 622
 - instance data 596
 - instantiating
 - COBOL 615
 - Java 615
 - name
 - external 595, 607
 - in a program 594
 - object, obtaining reference with JNI 634
 - user-defined 8

- class condition
 - testing
 - for DBCS 151
 - for Kanji 151
 - for numeric 54
 - overview 98
 - validating data 387
- CLASSPATH environment variable
 - description 465
 - example of setting 297
 - specifying location of Java classes 293
- client
 - defining 606
 - definition of 606
- CLIST for compiling under TSO 264
- CLOSE statement
 - line-sequential files 215
 - QSAM 170
 - VSAM 193
- closing files
 - line-sequential 217
 - multithreading serialization 520
 - QSAM
 - overview 173
 - with multithreading 173
 - VSAM
 - overview 200
 - with multithreading 201
- closing files, automatic
 - line-sequential 217
 - QSAM 173
 - VSAM 200
- cluster, VSAM 203
- cob2 command
 - compiling with
 - examples 286
 - overview 285
 - description 287
 - for compiling OO applications 291
 - for creating DLLs 286
 - for linking OO applications 292
 - input and output 289
 - linking with
 - examples 286
 - overview 285
 - options and syntax 287
- COBJVMINITOPTIONS environment variable
 - description 465
 - specifying JVM options 295
- COBOL
 - and Java
 - binding 296
 - communicating between 633
 - compatibility 300
 - compiling under z/OS UNIX 291
 - compiling using JCL or TSO/E 295
 - linking 292
 - running 293, 296
 - structuring applications 630
 - under IMS 458
 - object-oriented
 - binding 296
 - compiling under z/OS UNIX 291
- COBOL (continued)
 - object-oriented (continued)
 - compiling using JCL or TSO/E 295
 - linking 292
 - running 293
 - under IMS 458
- COBOL client
 - example 625
 - example of passing object references 612
- COBOL DLL programs, calling 513
- COBOL terms 23
- COBOL3 translator option 436
- COBOPT environment variable 283
- code
 - copy 675
 - optimized 667
- code page
 - conflict in XML documents 555
 - DBCS 315
 - definition 129
 - euro currency support 65
 - hexadecimal values of special characters 550
 - of DB2 string data 447
 - overriding 140
 - specifying 313
 - specifying for alphanumeric XML document 549
- code point, definition 129
- CODE-SET clause 14
- coded character set
 - definition 129
 - in XML documents 546
- CODEPAGE compiler option
 - DBCS code pages 315
 - description 313
 - for national literals 137
 - items that are not affected 314
 - operations that override 314
- coding
 - class definition 592
 - clients 606
 - condition tests 99
 - constructor methods 622
 - DATA DIVISION 11
 - decisions 93
 - efficiently 661
 - ENVIRONMENT DIVISION 5
 - errors, avoiding 661
 - EVALUATE statement 95
 - factory definition 621
 - factory methods 622
 - file input/output (overview) 153
 - IDENTIFICATION DIVISION 3
 - IF statement 93
 - input/output overview 156
 - input/output statements
 - for line-sequential files 215
 - for QSAM files 170
 - for VSAM files 193
 - instance methods 597, 619
 - interoperable data types with Java 638
 - loops 101
- coding (continued)
 - OO programs
 - must be reentrant 490
 - overview 589
 - PROCEDURE DIVISION 17
 - programs to run under CICS
 - calls 431
 - DISPLAY statement 430
 - I/O 430
 - must be reentrant 490
 - overview 429
 - restrictions 429
 - SORT statement 438
 - system date, getting 431
 - programs to run under DB2
 - CCSID of string data 447
 - overview 441
 - stored procedures must be reentrant 490
 - programs to run under IMS
 - must be reentrant 490
 - overview 453
 - restrictions 453
 - simplifying 675
 - SQL statements
 - overview 442
 - restriction 442
 - SQLIMS statements
 - overview 454
 - subclasses
 - example 620
 - overview 617
 - tables 67
 - techniques 11, 661
 - test conditions 99
- collating sequence
 - alternate
 - choosing 229
 - example 7
 - ASCII 7
 - binary for national keys 228
 - EBCDIC 7
 - HIGH-VALUE 7
 - ISO 7-bit code 7
 - LOW-VALUE 7
 - MERGE 7, 229
 - NATIVE 7
 - nonnumeric comparisons 6
 - ordinal position of a character 119
 - SEARCH ALL 7
 - SORT 7, 229
 - specifying 6
 - STANDARD-1 7
 - STANDARD-2 7
 - symbolic characters in the 8
- COLLATING SEQUENCE phrase
 - does not apply to national keys 228
 - overrides PROGRAM COLLATING SEQUENCE clause 6, 229
 - use in SORT or MERGE 229
- columns in tables 67
- COMMON attribute 4, 484
- COMP (COMPUTATIONAL) 48
- COMP-1 (COMPUTATIONAL-1)
 - format 50
 - performance tips 664

- COMP-2 (COMPUTATIONAL-2)
 - format 50
 - performance tips 664
- COMP-3 (COMPUTATIONAL-3) 50
- COMP-4 (COMPUTATIONAL-4) 48
- COMP-5 (COMPUTATIONAL-5) 49
- comparing data items 377
 - national
 - overview 147
 - to alphabetic, alphanumeric, or DBCS 149
 - to alphanumeric groups 149
 - to numeric 148
 - two operands 148
 - object references 609
 - zoned decimal and alphanumeric, effect of ZWB 379
- compatibility
 - Java and COBOL 300
 - object-oriented syntax 300
- compatibility mode 43, 685
- compilation
 - conformance to 85 COBOL Standard 304
 - results 274
 - with z/OS UNIX files 258
- compilation statistics 399
- COMPILE compiler option
 - description 316
 - use NOCOMPILE to find syntax errors 390
- compile-time considerations
 - compiler-directed errors 280
 - display compile and link steps 288
 - dump, generating a 322
 - error messages
 - determining what severity level to produce 328
 - severity levels 282
 - executing compile and link steps after display 288
- compiler
 - calculation of intermediate results 686
 - environment variables under z/OS UNIX 283
 - generating list of error messages 280
 - invoking in the z/OS UNIX shell
 - examples 286
 - overview 285
 - limits
 - DATA DIVISION 11
 - messages
 - choosing severity to be flagged 392
 - customizing 720
 - determining what severity level to produce 328
 - embedding in source listing 392
 - from exit modules 727
 - sending to terminal 271
 - severity levels 282, 721
 - return code
 - depends on highest severity 282
 - effect of message customization 722
 - overview 282
- compiler data sets
 - in the z/OS UNIX file system 256, 261
 - input and output 267
 - required for compilation 267
 - SYSADATA (ADATA records) 271
 - SYSIN 269
 - SYSJAVA 272
 - SYSLIB (libraries) 270
 - SYSLIN (object code) 271
 - SYSMDECK (library processing) 272
 - SYSOPTF 269
 - SYSOUT (listing) 270
 - SYPUNCH (object code) 271
 - SYSTEM (messages) 271
 - with cob2 289
- compiler listings
 - getting 395
- compiler options
 - 85 COBOL Standard conformance 304
 - abbreviations 301
 - ADATA 305
 - ADV 306
 - AFP 307
 - performance considerations 669
 - APOST 352
 - ARCH 307
 - performance considerations 669
 - ARITH
 - description 309
 - performance considerations 669
 - AWO
 - description 310
 - performance considerations 669
 - BLOCK0
 - description 310
 - performance considerations 669
 - BUFSIZE 312
 - CICS 312
 - CODEPAGE 313
 - COMPILE 316
 - conflicting 305
 - COPYRIGHT 316
 - CURRENCY 317
 - DATA 318
 - DBCS 319
 - DECK 319
 - DIAGTRUNC 320
 - DISPSIGN 320
 - DLL 322
 - DUMP 322
 - DYNAM 323, 670
 - EXIT 324
 - EXPORTALL 326
 - FASTSRT 231, 327
 - performance considerations 670
 - FLAG 328, 392
 - FLAGSTD 329
 - for CICS integrated translator 434
 - for CICS separate translator 433, 436
 - for debugging
 - overview 390
 - TEST restriction 388
 - THREAD restriction 388
 - HGPR 331
 - performance considerations 670
- compiler options (*continued*)
 - IMS, recommended for 457
 - in effect 407
 - INITCHECK 331
 - INTDATE 332
 - LANGUAGE
 - description 333
 - example in batch compilation 279
 - LINECOUNT 334
 - LIST 334, 395
 - MAP 335, 394, 395
 - MAXPCF 336
 - MAXPCF(nnn)
 - performance considerations 670
 - MDECK 338
 - NAME 339
 - NOCOMPILE 390
 - NOFASTSRT 233
 - NSYMBOL 340
 - NUMBER 340, 397
 - NUMCHECK 341
 - NUMPROC 343
 - NUMPROC(PFD)
 - performance considerations 670
 - NUMPROC(PFD|NOPFD) 54
 - OBJECT 344
 - OFFSET 345
 - on compiler invocation 399
 - OPTFILE 345
 - OPTIMIZE
 - description 346
 - performance considerations 667, 670
 - OUTDD 348
 - performance considerations 669
 - PGMNAME 348
 - precedence of
 - example 278
 - in batch 277
 - in SYSOPTF data sets 270, 346
 - under z/OS 272
 - under z/OS UNIX 284
 - QUALIFY 351
 - QUOTE 352
 - RENT
 - description 352
 - performance considerations 670
 - RMODE
 - description 353
 - performance considerations 671
 - RULES 354
 - SEQUENCE 356
 - SERVICE 356
 - signature information bytes 407
 - SOURCE 357, 395
 - SPACE 357
 - specifying 272
 - using PROCESS (CBL) 273
 - specifying under TSO 274
 - specifying under z/OS 274
 - specifying under z/OS UNIX 284
 - specifying with SYSOPTF data set 269
 - SQL
 - description 358
 - using with DB2 445

- compiler options (*continued*)
 - SQLCCSID
 - description 359
 - effect on CCSID of string data 447
 - performance considerations 448
 - recommended with DB2 coprocessor 448
 - SQLIMS 360
 - SSRANGE 361, 391
 - performance considerations 671
 - status 399
 - STGOPT 362
 - table of 301
 - TERMINAL 363
 - TEST
 - description 364
 - performance considerations 671
 - use for debugging 395
 - THREAD
 - debugging restriction 388
 - description 366
 - performance considerations 671
 - TRUNC
 - description 368
 - performance considerations 671
 - under IMS and CICS 430
 - VBREF 370, 395
 - VLR
 - description 371
 - VSAMOPENFS 372
 - WORD 372
 - XMLPARSE 373
 - XREF 374, 394
 - ZONECHECK 376
 - ZONEDATA 377
 - ZWB 379
- Compiler options
 - listing example 415
- compiler-directing statements
 - description 381
 - overview 20
- compiling
 - batch 275
 - control of 272
 - data sets for 267
 - DLLs 286
 - from an assembler program 265
 - OO applications
 - cob2 command 291
 - example 293, 298
 - under z/OS UNIX 291
 - using JCL or TSO/E 295
 - under TSO
 - example CLIST 264
 - overview 262
 - under z/OS 255
 - under z/OS UNIX 283
 - using shell script 289
 - using the cob2 command
 - examples 286
 - overview 285
 - with cataloged procedures 256
 - compile 257
 - compile and link-edit 258
 - compile, link-edit, run 259
 - with JCL (job control language) 256
- compiling and linking in the z/OS UNIX shell
 - DLLs 286
 - examples 286
 - OO applications
 - cob2 command 292
 - example 293
 - overview 285
- completion code
 - merge 230
 - sort 230
- complex OCCURS DEPENDING ON
 - basic forms of 81
 - complex ODO item 82
 - variably located data item 82
 - variably located group 82
- computation
 - arithmetic data items 663
 - of indexes 72
 - of subscripts 666
- COMPUTATIONAL (COMP) 48
- COMPUTATIONAL-1 (COMP-1)
 - format 50
 - performance tips 664
- COMPUTATIONAL-2 (COMP-2)
 - format 50
 - performance tips 664
- COMPUTATIONAL-3 (COMP-3)
 - description 50
- COMPUTATIONAL-4 (COMP-4) 48
- COMPUTATIONAL-5 (COMP-5) 49
- COMPUTE statement
 - assigning arithmetic results 34
 - simpler to code 56
- computer, describing 5
- concatenating data items (STRING) 105
- condition handling
 - closing QSAM files 173
 - closing VSAM files 200
 - in input or output procedures 225
 - using Language Environment 677
- condition testing 99
- conditional expression
 - EVALUATE statement 93
 - IF statement 93
 - PERFORM statement 103
- conditional statement
 - overview 19
 - with NOT phrase 19
 - with object references 609
- CONFIGURATION SECTION 5
- conflicting compiler options 305
- conformance requirements
 - 85 COBOL Standard 304
 - example of passing object references in INVOKE 612
 - RETURNING phrase of INVOKE 613
 - USING phrase of INVOKE 611
- Constant area 418
- constants
 - data items 662
 - definition 26
 - figurative, definition 26
- contained program integration 668
- CONTENT-CHARACTERS XML event
 - example 567
 - when parsing segments 544
- continuation
 - entry 235
 - of program 241
 - syntax checking 316
- CONTINUE statement 93
- control
 - in nested programs 484
 - program flow 93
 - transfer 473
- control interval size (CISZ), performance considerations 210, 673
- CONTROL statement 381
- converting data items
 - between code pages 119
 - between data formats 52
 - exceptions with national data 140
 - precision 52
 - reversing order of characters 117
 - to alphanumeric
 - with DISPLAY 36
 - with DISPLAY-OF 139
 - to Chinese GB 18030 from national 146
 - to integers with INTEGER, INTEGER-PART 114
 - to national
 - from Chinese GB 18030 146
 - from UTF-8 141
 - with ACCEPT 35
 - with MOVE 138
 - with NATIONAL-OF 139
 - to numbers with NUMVAL, NUMVAL-C 117
 - to uppercase or lowercase
 - with INSPECT 116
 - with intrinsic functions 117
 - to UTF-8 from national 141
 - with INSPECT 115
 - with intrinsic functions 116
- CONVERTING phrase (INSPECT), example 116
- coprocessor, DB2
 - CCSID determination of string data 447
 - differences from the precompiler 449
 - enable with SQL compiler option 445
 - overview 441
 - recommended compiler option SQLCCSID 448
 - using SQL INCLUDE with 443
- coprocessor, IMS
 - enable with SQLIMS compiler option 456
 - overview 453
- copy libraries
 - COPY statement 381
 - data set 267
 - example 676
 - search order 382
 - specifying 270
 - SYSLIB 270
 - z/OS UNIX search order 284, 288
- COPY statement
 - DB2 considerations 449
 - description 381
 - example 676
 - nested 675, 714

- COPY statement (*continued*)
 - z/OS considerations 270
 - z/OS UNIX considerations 382
 - copybook
 - description 381
 - obtaining from user-supplied module 325
 - searching for 288, 382
 - copybook cross-reference, description 394
 - copybooks
 - cross-reference 422
 - using 675
 - COPYRIGHT compiler option 316
 - COUNT IN phrase
 - UNSTRING 107
 - XML GENERATE 577
 - counting
 - characters (INSPECT) 115
 - generated XML characters 572
 - creating
 - associated-data file 271
 - library-processing output file 272
 - line-sequential files in z/OS 215
 - object code 271
 - objects 614
 - QSAM files, z/OS 174, 177
 - SYSJAVA file 272
 - variable-length tables 78
 - cross-reference
 - COPY/BASIS 422
 - COPY/BASIS statements 395
 - copybooks 395
 - data and procedure-names 394
 - embedded 395
 - list 374
 - program-name 422
 - special definition symbols 424
 - text-names and data sets 394
 - verb list 370
 - verbs 395
 - CRP (file position indicator) 195, 198
 - CURRENCY compiler option 317
 - currency signs
 - euro 65
 - hexadecimal literals 65
 - multiple-character 65
 - using 65
 - CURRENT-DATE intrinsic function
 - example 61
 - under CICS 431
 - customer support xviii, 863
- D**
- D-format record
 - layout 163
 - requesting 162
 - DASD (direct-access storage device) 210
 - data
 - concatenating (STRING) 105
 - converting between alphanumeric and DBCS 695
 - efficient execution 661
 - format conversion of 52
 - format, numeric types 46
 - grouping 496
 - data (*continued*)
 - incompatible 54
 - naming 12
 - numeric 43
 - passing 491
 - record size 13
 - splitting (UNSTRING) 107
 - validating 54
 - data and procedure-name cross-reference, description 394
 - data areas, dynamic 323
 - DATA compiler option
 - description 318
 - influencing data location 42
 - multioption interaction 40
 - performance considerations 669
 - when passing data 41
 - data definition 401
 - data description entry 11
 - DATA DIVISION
 - client 608
 - coding 11
 - description 11
 - entries for line-sequential files 214
 - entries for QSAM files 160
 - entries for VSAM files 192
 - factory data 622
 - factory method 623
 - FD entry 11
 - FILE SECTION 11
 - GROUP-USAGE NATIONAL clause 68
 - instance data 596, 619
 - instance method 599
 - items present in 407
 - limits 11
 - LINKAGE SECTION 11, 16
 - listing 395
 - LOCAL-STORAGE SECTION 11
 - mapping of items 335, 395
 - OCCURS clause 67
 - OCCURS DEPENDING ON (ODO) clause 78
 - REDEFINES clause 75
 - restrictions 11
 - signature information bytes 407
 - USAGE clause at the group level 25
 - USAGE IS INDEX clause 72
 - USAGE NATIONAL clause at the group level 134
 - WORKING-STORAGE SECTION 11
 - data item
 - alphanumeric with double-byte characters 695
 - coding Java types 637
 - common, in subprogram linkage 494
 - concatenating (STRING) 105
 - converting characters (INSPECT) 115
 - converting characters to numbers 117
 - converting to uppercase or lowercase 117
 - converting with intrinsic functions 116
 - counting characters (INSPECT) 115
 - DBCS 695
 - elementary, definition 24
 - data item (*continued*)
 - evaluating with intrinsic functions 119
 - finding the smallest or largest item 120
 - group, definition 24
 - index, referring to table elements with 70
 - initializing, examples of 28
 - map 274
 - numeric 43
 - reference modification 111
 - referring to a substring 111
 - replacing characters (INSPECT) 115
 - reversing characters 117
 - splitting (UNSTRING) 107
 - unused 346, 401
 - variably located 82
 - data manipulation
 - character data 105
 - DBCS data 695
 - DATA RECORDS clause 13
 - data set
 - alternate data-set names 265
 - checkpoint record 653
 - compiler-option 269
 - defining with environment variable 157
 - example of checkpoint/restart 657
 - file, same meaning as 5
 - JAVAERR 297
 - JAVAIN 297
 - JVAOOUT 297
 - names, alternate 265
 - output 270
 - source code 269
 - SYSADATA 271
 - SYSIN 269
 - SYSJAVA 272
 - SYSLIB 270
 - SYSLIN 271
 - SYSMDECK 272
 - SYSOPTF 269
 - SYSPRINT 270
 - SYSPUNCH 271
 - SYSTEM 271
 - data sets used for compiling 267
 - data-definition attribute codes 401
 - data-name
 - cross-reference 421
 - cross-reference list 275
 - in MAP listing 401
 - OMITTED 13
 - password for VSAM files 202
 - date and time operations
 - Language Environment callable services 677
 - date operations
 - finding date of compilation 123
 - DATE-COMPILED paragraph 3
 - DATE-OF-INTEGGER intrinsic function 61
 - DB2
 - coding considerations 441
 - coprocessor
 - CCSID determination of string data 447

- DB2 (*continued*)
 - coprocessor (*continued*)
 - database request module (DBRM) 442, 446
 - differences from the precompiler 449
 - enable with SQL compiler option 445
 - overview 441
 - recommended compiler option SQLCCSID 448
 - using SQL INCLUDE with 443
 - DYNAM compiler option with TSO or IMS 451
 - NODYNAM compiler option with CICS or CAF 451
 - precompiler
 - differences from the coprocessor 449
 - recommended compiler option NOSQLCCSID 448
 - specifying code page for host variables 443
 - SQL compiler option 445
 - SQL statements
 - CCSID determination 447
 - coding 442
 - overview 441
 - return codes 445
 - SQL DECLARE 443
 - SQL INCLUDE 443
 - using binary data in 445
 - using character data in 443
 - using national decimal data 444
 - SQLCCSID compiler option 447
- DBCS comparison 98
- DBCS compiler option
 - description 319
 - for Java interoperability 291, 295
 - for OO COBOL 291, 295
 - multioption interaction 305
- DBCS data
 - comparing
 - to national 149
 - converting
 - to alphanumeric with IGZCD2A 698
 - to and from alphanumeric 695
 - to national, overview 152
 - declaring 150
 - encoding and storage 137
 - literals
 - description 26
 - maximum length 151
 - using 150
 - MOVE statement with 32
 - notation for 695
 - testing for 151
- DBRM data set
 - defining 446
 - description 442
- DBRMLIB DD statement 442, 446
- DCB 169
- DD control statement
 - allocating line-sequential files 215
 - AMP parameter 206
 - ASCII tape files 183
- DD control statement (*continued*)
 - creating QSAM files 174, 177
 - DBRMLIB 446
 - DCB overrides data-set label 176
 - define file 8
 - defining merge data sets 226
 - defining sort data sets 226
 - JAVAERR 297
 - JAVAIN 297
 - JAVAOUT 297
 - RLS parameter 207
 - SYSADATA 271
 - SYSIN 269
 - SYSJAVA 272
 - SYSLIB 270
 - SYSLIN 271
 - SYSMDECK 272
 - SYSOPTF 269
 - SYSPRINT 270
 - SYSPUNCH 271
- ddname definition 8
- deadlock in I/O error declarative 244
- Debug Tool
 - compiler options for 395
 - description 385
- debugging
 - and performance 365
 - compiler options for
 - overview 390
 - TEST restriction 388
 - THREAD restriction 388
 - overview 385
 - runtime options for 388
 - using COBOL language features 386
 - using the debugger 395
- debugging, language features
 - class test 387
 - debugging lines 388
 - debugging statements 388
 - declaratives 388
 - DISPLAY statements 386
 - file status keys 387
 - INITIALIZE statements 388
 - scope terminators 386
 - SET statements 388
 - WITH DEBUGGING MODE clause 388
- DECK compiler option 319
- declarative procedures
 - EXCEPTION/ERROR 244
 - with multithreading 244
 - USE FOR DEBUGGING 388
- deferred restart 655
- defining
 - files, overview 8, 153
 - libraries 270
 - line-sequential files to z/OS 215
 - QSAM files
 - to z/OS 174, 177
 - sort or merge files under z/OS 226
 - VSAM files
 - to z/OS 203
- dek suffix with cob2 289
- DELETE statement
 - compiler-directing 383
 - multithreading serialization 520
 - VSAM, coding 193
- deleting records from VSAM file 200
- delimited scope statement
 - description of 19
 - nested 21
- DEPENDING ON clause 162, 192
- depth in tables 69
- device
 - classes 267
 - requirements 267
- DFHCOMMAREA parameter
 - calling nested CICS programs 432
 - calling separately compiled CICS programs 431
- DFHEIBLK parameter
 - calling nested CICS programs 432
 - calling separately compiled CICS programs 431
- DFSORT
 - defining data sets for 226
 - error message for RETURN statement 224
- diagnostics, program 399
- DIAGTRUNC compiler option 320
- direct-access
 - direct indexing 72
 - file organization 154
 - storage device (DASD) 210
- directories
 - adding a path to 288
- disability xx
- DISPLAY (USAGE IS)
 - encoding and storage 137
 - external decimal 47
 - floating point 48
- display floating-point data (USAGE DISPLAY) 48
- DISPLAY statement
 - directing output 348
 - displaying data values 35
 - displaying on the system logical output device 36
 - interaction with OUTDD 36
 - suppressing line spacing 37
 - under CICS 430
 - using in debugging 386
 - writing to stdout or stderr 36
- DISPLAY-1 (USAGE IS)
 - encoding and storage 137
- DISPLAY-OF intrinsic function
 - example with Chinese data 147
 - example with Greek data 140
 - example with UTF-8 data 141
 - using 139
 - with XML documents 548
- DISPSIGN compiler option 320
- DLL compiler option
 - description 322
 - for Java interoperability 291, 295
 - for OO COBOL 291, 295
 - multioption interaction 305
- DLL igzjava.x
 - binding with
 - example 298
 - preparing OO applications 297
 - linking with
 - example 293
 - preparing OO applications 292

- DLL libjvm.x
 - binding with
 - example 298
 - preparing OO applications 297
 - linking with
 - example 293
 - preparing OO applications 292
 - with EBCDIC services 644
- DLLs (see dynamic link libraries) 507
- do loop 103
- do-until 103
- do-while 103
- documentation of program 5
- DSA memory map 405
- dump
 - requesting 239
 - with DUMP compiler option 274
- DUMP compiler option
 - description 322
 - output 274
- DYNAM compiler option
 - description 323
 - multioption interaction 305
 - performance considerations 670
 - under DB2 with TSO or IMS 451
 - with dynamic calls 477
- dynamic calls
 - example 482
 - making 477
 - performance 481
 - restrictions 477
 - using with DLL linkage 512
 - when to use 478
 - with static calls 481
- dynamic data areas, allocating storage 42
- dynamic file allocation
 - order of allocation 157
 - using CBLQDA 171
 - using environment variables
 - line-sequential files 215
 - QSAM files 174
 - VSAM files 206
- dynamic link libraries
 - about 507
 - binder options for DLLs 509
 - compiler options required 286
 - compiling 508
 - creating
 - from the z/OS UNIX shell 286
 - overview 507
 - creating for OO 292
 - for Java interoperability 292
 - in OO COBOL applications 516
 - linking 509
 - programs with DLL support must be reentrant 490
 - search order for in z/OS UNIX file system 511
 - using CALL identifier with 510
 - using with C/C++ programs 515
 - using with dynamic calls 512
 - using with Java interoperability 293
 - using with OO 293

E

- E-level error message 282, 392
- EBCDIC
 - code pages supported in XML documents 546
 - converting to ASCII 119
 - JNI services 643
 - multibyte CCSIDs supported for
 - DBCS 315
- ECI calls and RETURN-CODE special register 433
- efficiency of coding 661
- EJECT statement 383
- embedded cross-reference
 - description 395
 - example 423
- embedded error messages 392
- embedded MAP summary 394, 402
- enclave 473
- encoding
 - conflicts in XML documents 555
 - controlling in generated XML output 576
 - description 137
 - language characters 129
 - of XML documents 546, 547
 - of XML documents to be parsed 530
 - specifying for alphanumeric XML document 549
 - specifying with CODEPAGE option 313
- encoding declaration
 - preferable to omit 549
 - specifying 549
- end-of-file (AT END phrase) 244
- END-OF-INPUT XML event
 - example 567
 - when parsing segments 543
- enhancing XML output
 - example of modifying data definitions 583
 - rationale and techniques 583
- ENTER statement 383
- entry point
 - alternate 489
 - alternate in ENTRY statement 488
 - ENTRY label 489
 - passing entry addresses of 487
 - procedure-pointer data item 487
- ENTRY statement
 - for alternate entry points 488
 - handling of program-name in 349
- ENVAR runtime option 297
- ENVIRONMENT DIVISION
 - class 594
 - client 607
 - collating sequence coding 6
 - CONFIGURATION SECTION 5
 - description 5
 - entries for line-sequential files 213
 - entries for QSAM files 159
 - entries for VSAM files 188
 - INPUT-OUTPUT SECTION 5
 - instance method 599
 - items present in, program
 - initialization code 407
 - signature information bytes 407

- ENVIRONMENT DIVISION (*continued*)
 - subclass 619
- environment variables
 - _BPX_SHAREAS 467
 - _CEE_ENVFILE
 - description 465
 - indicating Java settings 297
 - _CEE_RUNOPTS
 - description 465
 - setting XPLINK 299
 - specifying runtime options 463
 - _IGZ_SYSOUT 465
 - allocating line-sequential files 215
 - and copybooks 381
 - CLASSPATH
 - description 465
 - example of setting 297
 - specifying location of Java classes 293
 - COBJVMINIOPTIONS
 - description 465
 - specifying JVM options 295
 - COBOPT 283
 - compiler 283
 - defining files, example 8
 - defining QSAM files 174
 - example of setting and accessing 466
 - LIBPATH
 - description 465
 - example of setting 297
 - specifying location for COBOL classes 293
 - library-name 284, 381
 - PATH
 - description 465
 - example of setting 297
 - runtime 465
 - setting and accessing 464
 - STEPLIB
 - description 465
 - example 285
 - SYSLIB
 - description 284
 - specifying location of JNI.cpy 291
 - text-name 284, 381
 - using to allocate files 157
- environment-name 5
- ERRMSG, for generating list of error messages 280
- error
 - arithmetic 240
 - compiler options, conflicting 305
 - handling 239
 - handling for I/O 158
 - listing 274
 - message table
 - example using indexing 77
 - example using subscripting 77
 - processing
 - line-sequential files 218
 - QSAM files 174
 - VSAM files 201
 - XML GENERATE 577
 - XML PARSE 554
 - routines for handling 250

- error messages
 - compiler
 - choosing severity to be flagged 392
 - correcting source 280
 - customizing 720
 - determining what severity level to produce 328
 - embedding in source listing 392
 - format 281
 - from exit modules 727
 - generating a list of 280
 - location in listing 281
 - sending to terminal 271
 - severity levels 282, 721
 - compiler-directed 280
 - ESDS (entry-sequenced data sets)
 - file access mode 191
 - organization 188
 - euro currency sign 65
 - EVALUATE statement
 - case structure 95
 - coding 95
 - contrasted with nested IFs 96, 97
 - example that tests several conditions 97
 - example with multiple WHEN phrases 97
 - example with THRU phrase 96
 - performance 96
 - structured programming 662
 - testing multiple values, example 100, 101
 - use to test multiple conditions 93
 - evaluating data item contents
 - class test
 - for numeric 54
 - overview 98
 - INSPECT statement 115
 - intrinsic functions 119
 - exception condition
 - CALL 250
 - XML GENERATE 577
 - XML PARSE 554
 - exception handling
 - with Java 634
 - with XML GENERATE 577
 - with XML PARSE 552
 - EXCEPTION XML event 554
 - EXCEPTION/ERROR declarative
 - description 244
 - file status key 246
 - line-sequential error processing 218
 - QSAM error processing 174
 - VSAM error processing 201
 - EXEC control statement, RD parameter of 654
 - EXIT compiler option
 - considerations for SQL and CICS statements 728
 - description 324
 - MSGEXIT suboption 719
 - register usage 712
 - user-exit work area 711
 - using 324
 - exit modules
 - called for SYSADATA data set 717
 - exit modules (*continued*)
 - calling COBOL programs 712
 - error messages generated 727
 - message severity customization 719
 - used in place of library-name 713
 - used in place of SYSLIB 713
 - used in place of SYSPRINT 716
 - EXIT PROGRAM statement
 - in subprogram 474
 - with multithreading 474
 - explicit scope terminator 20
 - exponentiation
 - evaluated in fixed-point arithmetic 688
 - evaluated in floating-point arithmetic 693
 - performance tips 664
 - EXPORTALL compiler option
 - description 326
 - DLL considerations 508
 - multioption interaction 305
 - extended mode 43, 685
 - external class-name 595, 607
 - EXTERNAL clause
 - example for files 502
 - for data items 501
 - for sharing files 12, 501
 - external data
 - obtaining storage for 42
 - sharing 501
 - storage location of 42
 - external decimal data
 - national 47
 - zoned 47
 - external file 501
 - external floating-point data
 - display 48
 - national 48
 - External symbols 419
- F**
- F-format record
 - layout 162
 - requesting 161
- factoring expressions 662
- factory data
 - defining 622
 - definition of 589
 - making it accessible 622
 - private 622
- factory definition, coding 621
- factory methods
 - defining 622
 - definition of 589
 - hiding 623
 - invoking 624
 - using to wrap procedural programs 630
- FACTORY paragraph
 - factory data 622
 - factory methods 622
- factory section, defining 621
- FASTSRT compiler option
 - description 327
 - improving sort performance 231, 670
 - information message 231
- FASTSRT compiler option (*continued*)
 - requirements
 - JCL 231
 - QSAM 232
 - sort input and output files 231
 - VSAM 233
- FD (file description) entry 12
- figurative constants
 - definition 26
 - HIGH-VALUE restriction 132
 - national-character 132
- file access mode
 - choosing 155
 - dynamic 191
 - example 191
 - for indexed files (KSDS) 191
 - for relative files (RRDS) 191
 - for sequential files (ESDS) 191
 - performance considerations 210
 - random 191
 - sequential 191
 - summary table of 188
- file allocation 157
- file availability
 - QSAM files under z/OS 171
 - VSAM files under z/OS 202
- file description (FD) entry 12
- file organization
 - choosing 155
 - comparison of ESDS, KSDS, RRDS 187
 - indexed 154, 188
 - line-sequential 213
 - overview 153
 - QSAM 159
 - relative 154
 - relative-record 190
 - sequential 153, 188
 - VSAM 186
- file position indicator (CRP) 195, 198
- FILE SECTION
 - BLOCK CONTAINS clause 13
 - CODE-SET clause 14
 - DATA RECORDS clause 13
 - description 11
 - EXTERNAL clause 12
 - FD entry 12
 - GLOBAL clause 12
 - LABEL RECORDS clause 13
 - LINAGE clause 13
 - OMITTED 13
 - RECORD CONTAINS clause 13
 - record description 11
 - RECORD IS VARYING 13
 - RECORDING MODE clause 14
 - VALUE OF 13
- FILE STATUS clause
 - description 158
 - example 249
 - line-sequential error processing 218
 - NOFASTSRT error processing 233
 - QSAM error processing 174
 - using 245
 - VSAM error processing 201
 - with VSAM status code 246
- file status code
 - 02 198

- file status code (*continued*)
 - 30 197
 - 37 170
 - 39 170, 178, 182
 - 49 200
 - 90 168, 173, 201
 - 92 200, 466
 - file status key
 - 05 195
 - 35 195
 - 39 195
 - checking for I/O errors 245
 - checking for successful OPEN 245, 246
 - error handling 387
 - set for error handling 158
 - used with VSAM status code 246
 - VSAM, importance of in 201
 - FILE-CONTROL paragraph
 - example of entries 6
 - relation to FD entries 8
 - files
 - associating program files to external files 5
 - attributes 178
 - available
 - QSAM 171
 - VSAM 202
 - changing name 9
 - CICS, restrictions under 5
 - COBOL coding
 - DATA DIVISION entries 160, 192, 214
 - ENVIRONMENT DIVISION entries 159, 188, 213
 - input/output statements 170, 193, 215
 - overview 156
 - data sets, same meaning as 5
 - defining to operating system 8
 - describing 11
 - external 501
 - identifying to z/OS 174, 177, 203
 - line-sequential, allocating 215
 - multithreaded processing
 - example 522
 - recommended organization 521
 - recommended usage patterns 521
 - serialization 520
 - optional
 - QSAM 171
 - VSAM 196
 - overview 154
 - processing
 - line-sequential 213
 - QSAM 159
 - VSAM 185
 - with multithreading 520
 - sort performance
 - FASTSRT 231
 - variable-length files 226
 - storage of file-definition records 521
 - unavailable
 - QSAM 171
 - VSAM 203
 - usage explanation 9
 - FIPS messages
 - categories 721
 - FLAGSTD compiler option 329
 - fixed-length records
 - QSAM
 - layout 162
 - requesting 161
 - VSAM
 - defining 192
 - RRDS 186
 - fixed-point arithmetic
 - comparisons 63
 - evaluation 63
 - example evaluations 64
 - exponentiation 688
 - fixed-point data
 - binary 48
 - conversions and precision 52
 - conversions between fixed- and floating-point 52
 - external decimal 47
 - intermediate results 687
 - packed-decimal 50
 - planning use of 663
 - FLAG compiler option
 - compiler output 393
 - description 328
 - using 392
 - flags and switches 99
 - FLAGSTD compiler option 329
 - multioption interaction 305
 - floating-point arithmetic
 - comparisons 63
 - evaluation 63
 - example evaluations 64
 - exponentiation 693
 - floating-point data
 - conversions and precision 52
 - conversions between fixed- and floating-point 52
 - external 48
 - intermediate results 692
 - internal
 - format 50
 - performance tips 664
 - planning use of 663
 - format of record
 - fixed-length
 - defining for VSAM 192
 - layout of QSAM 162
 - requesting for QSAM 161
 - for QSAM ASCII tape 183
 - format D 183
 - layout 163
 - requesting 162
 - format F 183
 - layout 162
 - requesting 161
 - format S
 - layout 166
 - overview 165
 - requesting 164
 - format U 183
 - layout 167
 - requesting 166
 - format V 183
 - layout 163
 - format of record (*continued*)
 - format V (*continued*)
 - requesting 162
 - spanned
 - layout 166
 - overview 165
 - requesting 164
 - undefined
 - layout 167
 - requesting 166
 - variable-length
 - defining for VSAM 192
 - layout of QSAM 163
 - requesting for QSAM 162
 - formatted dump 239
 - freeing object instances 616
 - function-pointer data item
 - addressing JNI services 731
 - CALL statement 489
 - calling COBOL 489
 - calling DLL program
 - example 514
 - calling Language Environment services 489
 - definition 487
 - SET function-pointer 487
 - with DLLs 513
- ## G
- garbage collection 616
 - GB 18030 data
 - converting to or from national 146
 - processing 146
 - generating XML output
 - example 578
 - overview 571
 - get and set methods 603
 - GETMAIN, saving address of 711
 - GLOBAL clause for files 12, 16
 - global names 486
 - Glossary 829
 - GOBACK statement
 - in main program 474
 - in subprogram 474
 - with multithreading 474
 - group item
 - cannot subordinate alphanumeric group within national group 135
 - comparing to national data 149
 - definition 24
 - for defining tables 67
 - group move contrasted with elementary move 33, 135
 - initializing
 - using a VALUE clause 76
 - using INITIALIZE 30, 73
 - MOVE statement with 33
 - passing as an argument 496
 - treated as a group item
 - example with INITIALIZE 74
 - in INITIALIZE 31
 - variably located 82
 - group move contrasted with elementary move 33, 135
 - GROUP-USAGE NATIONAL clause
 - communicating with Java 638

- GROUP-USAGE NATIONAL clause
 - (continued)
 - defining a national group 134
 - defining tables 68
 - example of declaring a national group 24
 - initializing a national group 31
- grouping data to pass as an argument 496

H

- header on listing 5
- HEAP runtime option
 - influencing data location 42
 - multioption interaction 40
- hexadecimal literals
 - as currency sign 65
 - national
 - description 26
 - using 131
- HGPR compiler option 331
 - performance considerations 670
- hiding factory methods 623
- hierarchy of compiler options
 - in batch 277
 - in SYSOPTF data sets 346
 - under z/OS 272
 - under z/OS UNIX 284

I

- I-level message 282, 392
- IDENTIFICATION DIVISION
 - class 594
 - CLASS-ID paragraph 594, 618
 - client 606
 - coding 3
 - DATE-COMPILED paragraph 3
 - errors 3
 - listing header example 5
 - method 598
 - PROGRAM-ID paragraph 3
 - required paragraphs 3
 - subclass 618
 - TITLE statement 5
- IF statement
 - coding 93
 - nested 94
 - use EVALUATE instead for multiple conditions 94
 - with null branch 93
- IGZCA2D service routine 695
- IGZCD2A service routine 698
- igzcjava.x
 - binding with
 - example 298
 - preparing OO applications 297
 - linking with
 - example 293
 - preparing OO applications 292
- IGZEOPT module
 - with multithreading 524
- IGZETUN module
 - with multithreading 524
- IGZSRICD data set 235

- imperative statement, list 19
- implicit scope terminator 20
- IMS
 - COBOL-Java interoperability
 - accessing databases 460
 - calling COBOL method from Java 458
 - calling Java method from COBOL 459
 - messages 460
 - restriction on EXEC SQL 460
 - STOP RUN 460
 - synchronizing transactions 460
 - using the AIB 460
 - coding programs under
 - overview 453
 - restrictions 5, 453
 - compiling and linking for 457
 - coprocessor
 - overview 453
 - performance considerations 673
 - SQLIMS compiler option 456
 - SQLIMS statements 455
 - return codes 455
 - SQLIMS INCLUDE 454
 - using character data in 455
 - using EXEC SQL under IMS 460

IMS SQL

- coprocessor 454
- incrementing addresses 497
- index
 - assigning a value to 72
 - computation of element displacement, example 70
 - creating with OCCURS INDEXED BY clause 72
 - definition 70
 - incrementing or decrementing 72
 - initializing 72
 - key, detecting faulty 249
 - range checking 391
 - referencing other tables with 72
- index data item
 - cannot use as subscript or index 73
 - creating with USAGE IS INDEX clause 72
- indexed file organization
 - description 154
 - specifying 188
- indexing
 - computation of element displacement, example 70
 - definition 70
 - example 77
 - preferred to subscribing 664
 - tables 72
- INEXIT suboption of EXIT option
 - processing of 712
 - syntax 325
- inheritance hierarchy, definition of 591
- INITCHECK compiler option
 - description 331
- INITIAL attribute
 - effect on subprograms 476, 477
 - use of dynamic call and CANCEL instead 478

- INITIAL clause
 - effect on main program 475
 - effect on nested programs 5
 - setting programs to initial state 5
- INITIALIZE statement
 - examples 28
 - loading group values 30
 - loading national group values 31
 - loading table values 73
 - REPLACING phrase 73
 - using for debugging 388
- initializing
 - a group item
 - using a VALUE clause 76
 - using INITIALIZE 30, 73
 - a national group item
 - using a VALUE clause 76
 - using INITIALIZE 31, 74
 - a structure using INITIALIZE 30
 - a table
 - all occurrences of an element 76
 - at the group level 76
 - each item individually 75
 - using INITIALIZE 73
 - using PERFORM VARYING 103
 - examples 28
 - instance data 614
 - variable-length group 81
- inline PERFORM
 - example 102
 - overview 102
- input
 - coding for CICS 430
 - coding for line-sequential files 215
 - coding for QSAM files 170
 - coding for VSAM files 193
 - from files 153
 - to compiler, under z/OS 267
- input procedure
 - coding 222
 - example 228
 - FASTSORT option not effective 232
 - requires RELEASE or RELEASE FROM 223
 - restrictions 225
- INPUT-OUTPUT SECTION 5
- input/output
 - checking for errors 245
 - coding overview 156
 - controlling with FASTSORT option 327
 - logic flow after error 241
 - overview 153
 - processing errors
 - line-sequential files 218
 - QSAM files 174, 241
 - VSAM files 201, 241
- input/output coding
 - AT END (end-of-file) phrase 244
 - checking for successful operation 245
 - checking VSAM status codes 246
 - detecting faulty index key 249
 - error handling techniques 241
 - EXCEPTION/ERROR
 - declaratives 244
- INSERT statement 383
- INSPECT statement
 - avoid with UTF-8 data 551

INSPECT statement (*continued*)
 examples 115
 using 115
 inspecting data (INSPECT) 115
 instance
 creating 614
 definition of 589
 deleting 616
 instance data
 defining 596, 619
 definition of 589
 initializing 614
 making it accessible 603
 private 596
 instance methods
 defining 597, 619
 definition of 589
 invoking overridden 614
 overloading 602
 overriding 601
 INTDATE compiler option
 description 332
 effect on calendar starting date 60
 INTEGER intrinsic function,
 example 114
 INTEGER-OF-DATE intrinsic
 function 61
 INTEGER-PART intrinsic function 114
 integrated CICS translator
 advantages 435
 compiler options for 434
 overview 435
 interactive program, example 809
 Interactive System Productivity Facility
 (ISPF) 809
 interlanguage communication
 and PL/I tasking 523
 between COBOL and Java 633
 IMS applications 459
 subprograms 473
 under CICS 432
 with multithreading 523
 intermediate results 685
 internal floating-point data (COMP-1,
 COMP-2) 50
 interoperable data types with Java 638
 interrupts 651
 intrinsic functions
 as reference modifiers 114
 converting alphanumeric data items
 with 116
 converting national data items
 with 116
 evaluating data items 119
 example of
 ANNUITY 62
 CHAR 119
 CURRENT-DATE 61
 DISPLAY-OF 140
 INTEGER 114
 INTEGER-OF-DATE 61
 LENGTH 61, 121, 122
 LOG 62
 LOWER-CASE 117
 MAX 61, 89, 120, 121
 MEAN 62
 MEDIAN 62, 89

intrinsic functions (*continued*)
 example of (*continued*)
 MIN 114
 NATIONAL-OF 140
 NUMVAL 117
 NUMVAL-C 61, 117
 ORD 119
 ORD-MAX 89, 120
 PRESENT-VALUE 61
 RANGE 62, 89
 REM 62
 REVERSE 117
 SQRT 62
 SUM 89
 UPPER-CASE 117
 WHEN-COMPILED 123
 example of Unicode functions 144
 finding date of compilation 123
 finding largest or smallest item 120
 finding length of data items 122
 intermediate results 690, 693
 introduction to 38
 nesting 38
 numeric functions
 differences from Language
 Environment callable
 services 59
 equivalent Language Environment
 callable services 59
 examples of 58
 integer, floating-point, mixed 57
 nested 58
 special registers as arguments 58
 table elements as arguments 58
 uses for 57
 processing table elements 89
 UTF-8 142
 INVALID KEY phrase
 description 249
 example 249
 INVOKE statement
 RETURNING phrase 613
 USING phrase 611
 using to create objects 614
 using to invoke methods 610
 with ON EXCEPTION 611, 624
 with PROCEDURE DIVISION
 RETURNING 500
 invoking
 COBOL programs under z/OS 505
 COBOL programs under z/OS
 UNIX 463
 factory or static methods 624
 instance methods 610
 Language Environment callable
 services 679
 ISAM data set, analogous to VSAM KSDS
 data set 185
 ISPF (Interactive System Productivity
 Facility) 809

J

J2EE client
 example 645
 running 295

Java
 and COBOL
 binding 296
 communicating between 633
 compatibility 300
 compiling under z/OS UNIX 291
 compiling using JCL or
 TSO/E 295
 linking 292
 running 293, 296
 structuring applications 630
 array classes 638
 arrays
 declaring 639
 example 641
 manipulating 640
 boolean array 639
 boolean type 638
 byte array 639
 byte type 638
 char array 639
 char type 638
 class types 638
 double array 640
 double type 638
 example
 exception handling 635
 J2EE client 645
 processing an integer array 641
 exception
 catching 635
 example 635
 handling 634
 throwing 634
 float array 640
 float type 638
 global references
 JNI services for 637
 managing 636
 object 636
 passing 636
 int array 639
 int type 638
 interoperability 633
 interoperable data types, coding 638
 jstring class 638
 local references
 deleting 636
 freeing 637
 JNI services for 637
 managing 636
 object 636
 passing 636
 per multithreading 636
 saving 636
 long array 639
 long type 638
 methods
 access control 637
 object array 639
 running with COBOL
 under z/OS UNIX 293
 using JCL or TSO/E 296
 XPLINK linkage 299
 sharing data with 637
 short array 639
 short type 638

- Java (*continued*)
 - string array 639
 - strings
 - declaring 639
 - manipulating 642
- Java virtual machine
 - exceptions 635
 - initializing 294
 - object references 636
- java.lang.Object
 - referring to as Base 594
- javac command
 - compiling Java class definitions 291
 - recompile for Java 5 or Java 6 300
- JAVAERR data set 297
- JAVAIN data set 297
- JVAOUT data set 297
- JCL
 - ASCII tape files 183
 - cataloged procedures 256
 - example of checkpoint/restart 657
 - FASTSRT requirement 231
 - for compiling 256
 - for compiling in the z/OS UNIX file system 258
 - for line-sequential files 215
 - for merge 226
 - for OO applications 295
 - example 298
 - for QSAM files 176
 - for sort 226
 - for VSAM data sets 206
- JNI
 - accessing services 633
 - comparing object references 609
 - converting local references to global 614
 - EBCDIC services 643
 - environment structure 633
 - addressability for 633
 - exception handling services 634
 - Java array services 640
 - Java string services 642
 - obtaining class object reference 634
 - restrictions when using 634
 - Unicode services 642
 - UTF-8 services 644
- JNL.cpy
 - for compiling 291
 - for JNINativeInterface 633
 - listing 731
- JNIEnvPtr special register
 - use for JNI callable services 633
- JNINativeInterface
 - environment structure 633
 - JNL.cpy 633
- JOB control statement, RD parameter of 654
- job resubmission 657
- job stream 473
- jstring Java class 638

K

- Kanji comparison 98
- Kanji data, testing for 151
- keyboard navigation xxi

- keys
 - alternate in KSDS file 189
 - for binary search 87
 - for merging
 - defining 227
 - overview 220
 - for sorting
 - defining 227
 - overview 220
 - permissible data types
 - in MERGE statement 228
 - in OCCURS clause 68
 - in SORT statement 228
 - prime in KSDS file 188
 - relative-record 190
 - to specify order of table elements 68
- KSDS (key-sequenced data sets)
 - file access mode 191
 - organization 188

L

- LABEL RECORDS clause
 - FILE SECTION entry 13
- LANGUAGE compiler option
 - description 333
- Language Environment callable services
 - condition handling 677
 - corresponding math intrinsic functions 59
 - date and time computations 677
 - differences from intrinsic functions 59
 - dynamic storage services 677
 - example of using 680
 - feedback code 679
 - for date and time 60
 - for mathematics 59
 - invoking with CALL 679
 - mathematics 677
 - message handling 678
 - national language support 678
 - omitted feedback code 679
 - overview 677
 - return code 680
 - RETURN-CODE special register 680
 - sample list of 678
 - types of 677
- large block interface (LBI) 169
- largest or smallest item, finding 120
- last-used state
 - subprograms with EXIT PROGRAM or GOBACK 475
 - subprograms without INITIAL attribute 476, 477
- LBI (large block interface) 169
- LENGTH intrinsic function
 - compared with LENGTH OF special register 122
 - example 61, 122
 - using 119
 - variable-length results 121
 - with national data 122
- length of data items, finding 122
- LENGTH OF special register
 - passing 492
 - using 122

- level-88 item
 - conditional expressions 98
 - setting switches off, example 101
 - setting switches on, example 100
 - switches and flags 99
 - testing multiple values, example 100
 - testing single values, example 99
- level-number 401
- LIBEXIT suboption of EXIT option
 - processing of 713
 - syntax 325
- libjvm.x
 - binding with
 - example 298
 - preparing OO applications 297
 - linking with
 - example 293
 - preparing OO applications 292
 - with EBCDIC services 644
- LIBPATH environment variable
 - description 465
 - example of setting 297
 - specifying location for COBOL classes 293
- library
 - BASIS 270
 - COPY 270
 - defining 270
 - directory entry 265
 - specifying path for 381
- library-name
 - alternative if not specified 288
 - cross-reference to data-set names 422
 - when not used 713
- library-name environment variable 284
- limits of the compiler
 - DATA DIVISION 11
 - user data 11
- line number 400
- line-sequential files
 - adding records to 217
 - blocking 12
 - closing 217
 - closing to prevent reopening 216
 - control characters in 214
 - DATA DIVISION entries 214
 - ENVIRONMENT DIVISION entries 213
 - input/output error processing 218
 - input/output statements for 215
 - national data not supported 217
 - opening 216
 - organization 213
 - processing 213
 - reading from 215
 - reading records from 216
 - under z/OS
 - allocating 215
 - creating 215
 - job control language (JCL) 215
 - writing to 215
- LINECOUNT compiler option 334
- LINK macro 265
- LINKAGE SECTION
 - coding 495
 - for describing parameters 494
 - with recursive calls 17

- LINKAGE SECTION *(continued)*
 - with the THREAD option 17
 - linked-list processing, example 498
 - linking in the z/OS UNIX shell
 - c89 command 285
 - passing information to cob2 287
 - using the cob2 command
 - DLLs 286
 - examples 286
 - overview 285
 - linking OO applications
 - cob2 command 292
 - under z/OS UNIX
 - example 293
 - overview 292
 - using JCL or TSO/E
 - example 298
 - overview 296
 - LIST compiler option
 - assembler code for source program 405
 - base locator table 419
 - compiler output 407, 413
 - conflict with OFFSET option 395
 - Constant area section 418
 - description 334
 - DSA memory map 405, 420
 - External symbols section 419
 - getting output 395
 - MD5 signature example 414
 - multioption interaction 305
 - reading output 405
 - special register table 419
 - Static map section 417
 - symbols used in output 404
 - Timestamp and version information example 414
 - List of resources 863
 - listings
 - assembler expansion of PROCEDURE DIVISION 405
 - data and procedure-name cross-reference 394
 - embedded error messages 392
 - generating a short listing 396
 - line numbers, user-supplied 397
 - sorted cross-reference of program-names 422
 - sorted cross-reference of text-names 422
 - terms used in MAP output 403
 - text-name cross-reference 394
 - literals
 - alphanumeric
 - description 25
 - with DBCS content 151
 - DBCS
 - description 26
 - maximum length 151
 - using 150
 - definition 25
 - hexadecimal
 - using 131
 - national
 - description 26
 - using 131
 - numeric 26
 - literals *(continued)*
 - using 25
 - little-endian, converting to
 - big-endian 130
 - loading a table dynamically 73
 - local names 486
 - local references, converting to global 614
 - LOCAL-STORAGE SECTION
 - client 608, 609
 - comparison with WORKING-STORAGE
 - example 15
 - OO client 609
 - overview 14
 - determining location 42
 - LOG intrinsic function 62
 - logical record
 - description 153
 - fixed-length format
 - defining for VSAM 192
 - requesting for QSAM 161
 - QSAM, definition 160
 - variable-length format
 - defining for VSAM 192
 - layout for QSAM 163
 - requesting for QSAM 162
 - loops
 - coding 101
 - conditional 103
 - do 103
 - in a table 103
 - performed an explicit number of times 103
 - LOWER-CASE intrinsic function 117
 - lowercase, converting to 117
 - lst suffix with cob2 289
- M**
- main program
 - accessing parameter list in z/OS
 - example 505
 - overview 505
 - accessing parameter list in z/OS UNIX
 - example 469
 - overview 468
 - and subprograms 473
 - dynamic calls 477
 - main storage, allocating to buffers 312
 - MAP compiler option
 - data items and relative addresses 274
 - description 335
 - embedded MAP summary 395
 - example 400, 405
 - nested program map 395
 - example 405
 - symbols used in output 404
 - terms used in output 403
 - using 394, 395
 - mapping of DATA DIVISION items 395
 - mathematics
 - intrinsic functions 58, 62
 - Language Environment callable services 59, 677
 - MAX intrinsic function
 - example table calculation 89
 - MAX intrinsic function *(continued)*
 - example with functions 61
 - using 120
 - MAXPCF compiler option 336
 - MDECK compiler option
 - description 338
 - MEAN intrinsic function
 - example statistics calculation 62
 - example table calculation 89
 - MEDIAN intrinsic function
 - example statistics calculation 62
 - example table calculation 89
 - memory map
 - DSA 405
 - merge
 - alternate collating sequence 229
 - completion code 230
 - criteria 227
 - data sets needed under z/OS 226
 - DD statements for defining z/OS data sets 226
 - description 219
 - determining success 230
 - diagnostic message 230
 - files, describing 221
 - keys
 - defining 227
 - overview 220
 - pass control statements to 235
 - process 220
 - restrictions 219
 - storage use 235
 - terminating 231
 - work files
 - describing 220
 - MERGE statement
 - ASCENDING | DESCENDING KEY phrase 228
 - COLLATING SEQUENCE phrase 7, 229
 - description 226
 - GIVING phrase 226
 - overview 219
 - restrictions 219
 - USING phrase 226
 - message handling, Language Environment callable services 678
 - messages
 - compiler
 - choosing severity to be flagged 392
 - customizing 720
 - determining what severity level to produce 328
 - embedding in source listing 392
 - generating a list of 280
 - sending to terminal 271
 - severity levels 282, 721
 - compiler-directed 280
 - from exit modules 727
 - sending to SYSTERM 363
 - METHOD-ID paragraph 598
 - methods
 - constructor 622
 - factory 622
 - hiding factory 623
 - instance 597, 619

- methods (*continued*)
 - invoking 610, 624
 - invoking superclass 614
 - Java access control 637
 - obtaining passed arguments 601
 - overloading 602
 - overriding 601, 623
 - returning a value from 601
 - signature 598
- migration considerations
 - Java and COBOL 300
- MIN intrinsic function
 - example 114
 - using 120
- mixed DBCS/EBCDIC literal
 - alphanumeric to DBCS
 - conversion 695
 - DBCS to alphanumeric
 - conversion 698
- mnemonic-name
 - SPECIAL-NAMES paragraph 5
- MOVE statement
 - assigning arithmetic results 34
 - converting to national data 138
 - CORRESPONDING 33
 - effect of ODO on lengths of sending
 - and receiving items 79
 - group move contrasted with
 - elementary move 33, 135
 - with elementary receiving items 32
 - with group receiving items 33
 - with national items 32
- MSGEXIT suboption of EXIT option
 - effect on compilation return code 722
 - example user exit 723
 - message severity levels 721
 - processing of 719
 - syntax 326
- MSGFILE runtime option 348
- multiple currency signs
 - example 66
 - using 65
- multiple inheritance, not permitted 592, 617
- multiple thread environment, running
 - in 366
- multithreading
 - AMODE setting 523
 - asynchronous signals 523
 - choosing data section 517
 - in an OO client 609
 - closing QSAM files 173
 - closing VSAM files 201
 - COBOL programs 517
 - coding file I/O
 - example 522
 - recommended organization 521
 - recommended usage patterns 521
 - serialization 520
 - control transfer 519
 - ending programs 520
 - EXIT PROGRAM statement 474
 - GOBACK statement 474
 - I/O error declaratives 244
 - IGZEOPT 524
 - IGZETUN 524
 - interlanguage communication 523

- multithreading (*continued*)
 - limitations 523
 - nested programs 523
 - older compilers 524
 - overview 517
 - preinitializing 519
 - preparing COBOL programs for 517
 - recursion 519
 - recursive requirement 523
 - reentrancy 523
 - reentrancy requirement 523
 - runtime restrictions 524
 - sort and merge restriction 219
 - STOP RUN statement 474
 - synchronizing access to
 - resources 523
 - terminology 518
 - THREAD compiler option
 - restrictions with 367
 - when to choose 519
 - UPSI switches 524
 - with PL/I tasks 523

N

- N delimiter for national or DBCS
 - literals 26
- NAME compiler option
 - description 339
 - using 3
- name declaration
 - searching for 486
- NAMESPACE-DECLARATION XML
 - event 538
- naming
 - files 8
 - programs 3
- NATIONAL (USAGE IS)
 - external decimal 47
 - floating point 48
- national comparison 98
- national data
 - communicating with Java 638
 - comparing
 - overview 147
 - to alphabetic, alphanumeric, or DBCS 149
 - to alphanumeric groups 149
 - to numeric 148
 - two operands 148
 - concatenating (STRING) 105
 - converting
 - exceptions 140
 - from alphanumeric or DBCS with NATIONAL-OF 139
 - from alphanumeric, DBCS, or integer with MOVE 138
 - overview 138
 - to alphanumeric with DISPLAY-OF 139
 - to numbers with NUMVAL, NUMVAL-C 117
 - to or from Chinese GB 18030 146
 - to or from Greek alphanumeric, example 140
 - to or from UTF-8 141
 - to uppercase or lowercase 117

- national data (*continued*)
 - converting (*continued*)
 - with INSPECT 115
 - defining 131
 - displaying on output 36
 - encoding in XML documents 547
 - evaluating with intrinsic
 - functions 119
 - external decimal 47
 - external floating-point 48
 - figurative constants 132
 - finding the smallest or largest
 - item 120
 - in conditional expressions 147, 148
 - in generated XML documents 572
 - in keys
 - in MERGE statement 228
 - in OCCURS clause 68
 - in SORT statement 228
 - initializing, example of 29
 - input with ACCEPT 35
 - inspecting (INSPECT) 115
 - LENGTH intrinsic function and 122
 - LENGTH OF special register 122
 - literals
 - using 131
 - MOVE statement with 32, 138
 - NSYMBOL compiler option if no
 - USAGE clause 131
 - reference modification of 112
 - reversing characters 117
 - specifying 130
 - splitting (UNSTRING) 108
 - VALUE clause with alphanumeric
 - literal, example 121
- national decimal data (USAGE NATIONAL)
 - defining 133
 - example 43
 - format 47
 - initializing, example of 29
- national floating-point data (USAGE NATIONAL)
 - defining 133
 - definition 48
- national group item
 - advantages over alphanumeric
 - groups 133
 - can contain only national data 24, 135
 - communicating with Java 638
 - contrasted with USAGE NATIONAL
 - group 25
 - defining 134
 - example 24
 - for defining tables 68
 - in generated XML documents 572
 - initializing
 - using a VALUE clause 76
 - using INITIALIZE 31, 74
 - LENGTH intrinsic function and 122
 - MOVE statement with 33
 - overview 133
 - passing as an argument 496
 - treated as a group item
 - example with INITIALIZE 136
 - in INITIALIZE 31

- national group item (*continued*)
 - treated as a group item (*continued*)
 - in MOVE CORRESPONDING 33
 - summary 136
 - treated as an elementary item
 - example with MOVE 33
 - in most cases 24, 133
 - using
 - as an elementary item 135
 - overview 134
 - VALUE clause with alphanumeric literal, example 76
- national language support (NLS)
 - DBCS 150
 - LANGUAGE compiler option 333
 - processing data 125
- national literals
 - description 26
 - using 131
- national-edited data
 - defining 131
 - editing symbols 131
 - initializing
 - example 29
 - using INITIALIZE 74
 - MOVE statement with 32
 - PICTURE clause 131
- NATIONAL-OF intrinsic function
 - example with Chinese data 147
 - example with Greek data 140
 - example with UTF-8 data 141
 - using 139
 - with XML documents 548
- nested COPY statement 675, 714
- nested delimited scope statements 21
- nested IF statement
 - coding 94
 - CONTINUE statement 93
 - EVALUATE statement preferred 94
 - with null branches 93
- nested intrinsic functions 58
- nested program integration 668
- nested program map
 - description 395
 - example 405
- nested programs
 - calling 484
 - description 484
 - effect of INITIAL clause 5
 - guidelines 484
 - map 395, 405
 - scope of names 486
 - transfer of control 484
- nesting level
 - program 400, 405
 - statement 400
- NOCBLCARD translator option 436
- NOCOMPILE compiler option
 - use to find syntax errors 390
- NODLL compiler option
 - with dynamic calls 477
 - with static calls 476
- NODYNAM compiler option
 - under CICS 432
 - under DB2 with CICS or CAF 451
 - with static and dynamic calls 481
 - with static calls 476
- NODYNAM compiler option (*continued*)
 - with stored procedures 451
- NOFASTSORT compiler option 233, 236
- NORENT compiler option
 - multioption interaction 305
- NOSIMVRD runtime option 190
- NOSQLCCSID compiler option
 - recommended for compatibility with DB2 precompiler 448
- Notices 825
- NSYMBOL compiler option
 - description 340
 - effect on N literals 26
 - for DBCS literals 131
 - for national data items 131
 - for national literals 131
 - multioption interaction 305
- null branch 93
- null-terminated strings
 - example 111
 - handling 496
 - manipulating 110
- NUMBER compiler option
 - description 340
 - for debugging 397
- NUMCHECK compiler option 341
- NUMCLS installation option, effect on numeric class test 55
- numeric class test
 - checking for valid data 54
 - effect of NUMPROC, NUMCLS 55
- numeric comparison 98
- numeric data
 - binary
 - USAGE BINARY 48
 - USAGE COMPUTATIONAL (COMP) 48
 - USAGE COMPUTATIONAL-4 (COMP-4) 48
 - USAGE COMPUTATIONAL-5 (COMP-5) 49
 - can compare algebraic values regardless of USAGE 149
 - comparing to national 148
 - converting
 - between fixed- and floating-point 52
 - precision 52
 - to national with MOVE 138
 - defining 43
 - display floating-point (USAGE DISPLAY) 48
 - editing symbols 45
 - external decimal
 - USAGE DISPLAY 47
 - USAGE NATIONAL 47
 - external floating-point
 - USAGE DISPLAY 48
 - USAGE NATIONAL 48
 - internal floating-point
 - USAGE COMPUTATIONAL-1 (COMP-1) 50
 - USAGE COMPUTATIONAL-2 (COMP-2) 50
 - national decimal (USAGE NATIONAL) 48
- numeric data (*continued*)
 - national floating-point (USAGE NATIONAL) 48
 - packed-decimal
 - sign representation 53
 - USAGE COMPUTATIONAL-3 (COMP-3) 50
 - USAGE PACKED-DECIMAL 50
 - PICTURE clause 43, 45
 - storage formats 46
 - USAGE DISPLAY 43
 - USAGE NATIONAL 43
 - zoned decimal (USAGE DISPLAY)
 - format 48
 - sign representation 53
- numeric intrinsic functions
 - differences from Language Environment callable services 59
 - equivalent Language Environment callable services 59
 - example of
 - ANNUITY 62
 - CURRENT-DATE 61
 - INTEGER 114
 - INTEGER-OF-DATE 61
 - LENGTH 61, 121
 - LOG 62
 - MAX 61, 89, 120, 121
 - MEAN 62
 - MEDIAN 62, 89
 - MIN 114
 - NUMVAL 117
 - NUMVAL-C 61, 117
 - ORD 119
 - ORD-MAX 89
 - PRESENT-VALUE 61
 - RANGE 62, 89
 - REM 62
 - SQRT 62
 - SUM 89
 - integer, floating-point, mixed 57
 - nested 58
 - special registers as arguments 58
 - table elements as arguments 58
 - uses for 57
- numeric literals, description 26
- numeric-edited data
 - BLANK WHEN ZERO clause
 - coding with numeric data 131
 - example 45
 - defining 131
 - editing symbols 45
 - initializing
 - examples 30
 - using INITIALIZE 74
 - PICTURE clause 45
 - USAGE DISPLAY
 - displaying 45
 - initializing, example of 30
 - USAGE NATIONAL
 - displaying 45
 - initializing, example of 30
- NUMPROC compiler option
 - affected by NUMCLS 55
 - description 343
 - effect on sign processing 54
 - performance considerations 670

NUMVAL intrinsic function
 description 117
 NUMVAL-C intrinsic function
 description 117
 example 61
 NX delimiter for national literals 26

O

o suffix with cob2 289
 object
 creating 614
 definition of 589
 deleting 616
 object code
 compilation and listing 274
 creating 271
 generating 316
 producing in 80-column record 319
 OBJECT compiler option
 description 344
 multioption interaction 305
 object instances, definition of 589
 OBJECT paragraph
 instance data 596, 619
 instance methods 597
 object references
 comparing 609
 converting from local to global 614
 example of passing 612
 setting 609
 typed 608
 universal 608
 OBJECT-COMPUTER paragraph 5
 object-oriented COBOL
 binding
 example 298
 overview 296
 calls to and from OO programs 487
 communicating with Java 638
 compatibility 300
 compiling
 under z/OS UNIX 291
 using JCL or TSO/E 295
 DLLs in 516
 IMS
 accessing databases 460
 calling COBOL method from
 Java 458
 calling Java method from
 COBOL 459
 linking
 example 293
 overview 292
 preparing applications
 under z/OS UNIX 292
 using JCL or TSO/E 296
 programs must be reentrant 490
 restrictions
 cannot run under CICS 429
 CICS 589
 EXEC CICS statements 589
 EXEC SQL statements 589
 sort and merge 219
 SQL compiler option 589
 SQL statements 442

object-oriented COBOL (*continued*)
 running
 under z/OS UNIX 293
 using JCL or TSO/E 296
 XPLINK linkage 299
 writing OO programs 589
 OCCURS clause
 ASCENDING | DESCENDING KEY
 phrase
 example 88
 needed for binary search 87
 specify order of table elements 68
 cannot use in a level-01 item 68
 defining tables 67
 for defining table elements 68
 INDEXED BY phrase for creating
 indexes 72
 nested for creating multidimensional
 tables 68
 OCCURS DEPENDING ON (ODO)
 clause
 complex 81
 for creating variable-length tables 78
 initializing ODO elements 81
 ODO object 78
 ODO subject 78
 optimization 665
 simple 78
 variable-length records
 QSAM 162
 VSAM 192
 OCCURS INDEXED BY clause, creating
 indexes with 72
 ODO object 78
 ODO subject 78
 OFFSET compiler option
 description 345
 multioption interaction 305
 output 424
 OMITTED clause, FILE SECTION 13
 OMITTED parameters 679
 OMITTED phrase for omitting
 arguments 495
 ON EXCEPTION phrase
 INVOKE statement 611, 624
 OPEN statement
 file availability 170, 195, 216
 file status key 245
 line-sequential files 215
 multithreading serialization 520
 QSAM files 170
 VSAM files 193
 opening files
 line-sequential 216
 multithreading serialization 520
 QSAM 170
 VSAM
 empty 196
 overview 195
 OPTFILE compiler option 345
 optimization
 avoid ALTER statement 662
 BINARY data items 663
 consistent data 663
 constant data items 662
 contained program integration 668
 effect of compiler options on 668

optimization (*continued*)
 effect on parameter passing 494
 effect on performance 662
 factor expressions 662
 index computations 666
 indexing 664
 nested program integration 668
 OCCURS DEPENDING ON 665
 out-of-line PERFORM 662
 packed-decimal data items 663
 performance implications 665
 procedure integration 668
 structured programming 662
 subscript computations 666
 subscripting 664
 table elements 664
 top-down programming 662
 unreachable code 667
 unused data items 346, 401
 OPTIMIZE compiler option
 description 346
 effect on parameter passing 494
 performance considerations 667, 670
 optimizer
 overview 667
 optional files
 QSAM 171
 VSAM 196
 ORD intrinsic function, example 119
 ORD-MAX intrinsic function
 example table calculation 89
 using 120
 ORD-MIN intrinsic function 120
 order of evaluation
 arithmetic operators 57, 687
 compiler options 305
 out-of-line PERFORM 102
 OUTDD compiler option
 DD not allocated 36
 description 348
 interaction with DISPLAY 36
 output
 coding for CICS 430
 coding for line-sequential files 215
 coding for QSAM files 170
 coding for VSAM files 193
 data set 270
 from compiler, under z/OS 268
 to files 153
 output files with cob2 289
 output procedure
 coding 224
 example 224, 228
 FASTSORT option not effective 232
 requires RETURN or RETURN
 INTO 224
 restrictions 225
 overflow condition
 CALL 250
 joining and splitting strings 240
 UNSTRING 107
 overloading instance methods 602
 overriding
 factory methods 623
 instance methods 601

P

- packed decimal data 341
- packed-decimal data item
 - description 50
 - sign representation 53
 - synonym 47
 - using efficiently 50, 663
- page
 - control 172
 - depth 13
- paragraph
 - definition 18
 - grouping 104
- parameters
 - accessing from main program in z/OS
 - example 505
 - overview 505
 - accessing from main program in z/OS UNIX
 - example 469
 - overview 468
 - ADEXIT 718
 - describing in called program 494
 - INEXIT 712
 - LIBEXIT 715
 - MSGEXIT 719
 - PRTEXIT 717
- parse data item, definition 530
- parsing XML documents
 - description 530
 - one segment at a time
 - example 566
 - overview 543
 - overview 528
 - UTF-8 551
 - white space 548
 - with validation
 - example 568
 - overview 540
 - performance considerations 541
 - restrictions 541
 - XML declaration 548
- passing data between programs
 - addresses 497
 - arguments in calling program 493
 - BY CONTENT 491
 - BY REFERENCE 491
 - BY VALUE
 - overview 491
 - restrictions 493
 - EXTERNAL data 501
 - JNI services 634
 - OMITTED arguments 495
 - options considerations 41
 - parameters in called program 494
 - RETURN-CODE special register 500
 - with Java 637
- password
 - alternate index 202
 - example 202
 - VSAM files 202
- PASSWORD clause 202
- PATH environment variable
 - description 465
 - example of setting 297
- path name
 - for copybook search 288, 381
- PERFORM statement
 - coding loops 101
 - for a table
 - example using indexing 77
 - example using subscripting 77
 - for changing an index 72
 - inline 102
 - out-of-line 102
 - performed an explicit number of times 103
 - TEST AFTER 103
 - TEST BEFORE 103
 - THRU 104
 - TIMES 103
 - UNTIL 103
 - VARYING 103
 - VARYING WITH TEST AFTER 103
 - WITH TEST AFTER . . . UNTIL 103
 - WITH TEST BEFORE . . . UNTIL 103
- performance
 - AIXBLD runtime option 673
 - and debugging 365
 - APPLY WRITE-ONLY clause 10
 - arithmetic evaluations 663
 - arithmetic expressions 664
 - blocking QSAM files 168, 310
 - calls 481
 - CBLPSHPOP considerations 439
 - CBLPSHPOP runtime option 439
 - CICS
 - overview 661
 - CICS coding 672
 - coding for 661
 - coding tables 664
 - compiler option
 - AFP 669
 - ARCH 669
 - ARITH 669
 - AWO 669
 - BLOCK0 669
 - DYNAM 670
 - FASTSRT 670
 - HGPR 670
 - MAXPCF 670
 - NUMPROC 54, 670
 - OPTIMIZE 667, 670
 - RENT 670
 - RMODE 671
 - SQLCCSID 448
 - SSRANGE 671
 - TEST 671
 - THREAD 367, 671
 - TRUNC 368, 671
 - consistent data types 663
 - data usage 663
 - effect of compiler options on 668
 - effects of buffer size 312
 - exponentiations 664
 - FASTSRT 231
 - IMS environment 457, 673
 - OCCURS DEPENDING ON 665
 - optimizer
 - overview 667
 - order of WHEN phrases in EVALUATE 96
 - out-of-line PERFORM compared with inline 102
- performance (*continued*)
 - parsing XML documents with validation 541
 - programming style 662
 - sorting with FASTSRT 231
 - striped extended-format QSAM data sets 180
 - table handling 666
 - table searching
 - binary compared with serial 85
 - improving serial search 86
 - tape, QSAM 169
 - tuning 661
 - variable subscript data format 71
 - VSAM files 209, 673
 - worksheet 672
- period as scope terminator 20
- PGMNAME compiler option
 - COMPAT suboption 349
 - description 348
 - LONGMIXED suboption 350
 - LONGUPPER suboption 349
- phrase, definition of 18
- physical block 153
- physical record 14, 153
- PICTURE clause
 - cannot use for internal floating point 44
 - determining symbol used 317
 - incompatible data 54
 - N for national data 131
 - national-edited data 131
 - numeric data 43
 - numeric-edited data 131
 - Z for zero suppression 45
- PL/I tasking
 - POSIX runtime option 523
 - with COBOL 523
- pointer data item
 - description 39
 - incrementing addresses with 497
 - NULL value 497
 - passing addresses 497
 - processing chained lists 497
 - used to process chained list 498
- porting applications
 - effect of separate sign 44
- POSIX
 - calling APIs 466
 - threads 523
- POSIX runtime option
 - effect on DLL search order 511
 - use in OO applications 297
- precedence
 - arithmetic operators 57, 687
 - CICS options 434
 - compiler options
 - in batch 277
 - in SYSOPTF data sets 270, 346
 - under z/OS 272
 - under z/OS UNIX 284
 - copybook search order 284
- preferred sign 54
- preinitializing the COBOL environment with multithreading 519
- PRESENT-VALUE intrinsic function 61

- preserving original sequence in a
 - sort 230
- priority numbers, segmentation 668
- procedure and data-name cross-reference,
 - description 394
- PROCEDURE DIVISION
 - additional information 407
 - client 606
 - description 17
 - in subprograms 496
 - instance method 600
- RETURNING
 - to return a value 17
 - using 500
- signature information bytes 407
- statements
 - compiler-directing 20
 - conditional 19
 - delimited scope 19
 - imperative 19
- terminology 17
- USING
 - BY VALUE 496
 - to receive parameters 17, 494
 - verbs present in 407
- procedure integration 668
- procedure-pointer data item
 - calling C/C++ 489
 - calling JNI services 489
 - definition 487
 - entry address for entry point 487
 - passing parameters to callable
 - services 487
 - SET procedure-pointer 487
 - with DLLs 513
- process
 - definition 518
- PROCESS (CBL) statement
 - batch compiling 277
 - conflicting options in 305
 - overview 383
 - precedence
 - in batch 277
 - under z/OS 272
 - under z/OS UNIX 284
 - specifying compiler options 273
- processing
 - chained lists
 - example 498
 - overview 497
 - tables
 - example using indexing 77
 - example using subscripting 77
- producing XML output 571
- product support xviii, 863
- program
 - attribute codes 405
 - compiling and linking using cob2
 - DLLs 286
 - examples 286
 - overview 285
 - compiling under z/OS 255
 - compiling under z/OS UNIX 283
 - decisions
 - EVALUATE statement 93
 - IF statement 93
 - loops 103

- program (*continued*)
 - decisions (*continued*)
 - PERFORM statement 103
 - switches and flags 99
 - developing for z/OS UNIX 463
 - diagnostics 399
 - initialization code 413
 - limitations 661
 - main 473
 - nesting level 400
 - reentrant 490
 - restarting 654
 - signature information bytes 407
 - statistics 399
 - structure 3
 - subprogram 473
- PROGRAM COLLATING SEQUENCE
 - clause
 - does not affect national or DBCS
 - operands 7
 - establishing collating sequence 6
 - overridden by COLLATING
 - SEQUENCE phrase 6
 - overrides default collating
 - sequence 229
- Program information
 - listing example 415
- program processing table 432
- Program prolog area
 - listing example 416
- program termination
 - actions taken in main and
 - subprogram 474
 - statements 474
- PROGRAM-ID paragraph
 - coding 3
 - COMMON attribute 4
 - INITIAL clause 5
- program-names
 - avoid using certain prefixes 3
 - cross-reference 422
 - handling of case 348
 - specifying 3
- protecting VSAM files 202
- PRTEXT suboption of EXIT option
 - processing of 716
 - syntax 325

Q

- QSAM files
 - adding records to 172
 - ASCII tape file 182
 - ASSIGN clause 160
 - attributes 178
 - BLOCK CONTAINS clause 168, 310
 - block size 168, 310
 - blocking enhances performance 168, 310
 - blocking records 168, 181
 - closing 173
 - closing to prevent reopening 171
 - DATA DIVISION entries 160
 - ENVIRONMENT DIVISION
 - entries 159
 - FASTSRT requirements 232

- QSAM files (*continued*)
 - input/output error processing 174, 241
 - input/output statements for 170
 - obtaining buffers for 181
 - opening 170
 - processing
 - existing files 179
 - in reverse order 171
 - new files 180
 - overview 159
 - z/OS UNIX files 181
 - replacing records 172
 - retrieving 177
 - striped extended-format 180
 - tape performance 169
 - under z/OS
 - creating files 174, 177
 - DD statement for 174, 177
 - defining 174, 177
 - environment variable for 174
 - file availability 171
 - job control language (JCL) 176
 - updating files 172
 - using same input/output file under
 - FASTSRT 232
 - writing to a printer 172
- QUALIFY compiler option 351
- QUOTE compiler option 352

R

- railroad track diagrams, how to read xvi
- random numbers, generating 59
- RANGE intrinsic function
 - example statistics calculation 62
 - example table calculation 89
- RD parameter of JOB or EXEC
 - statement 654
- READ INTO for format-V VSAM
 - files 193
- READ NEXT statement 193
- READ statement
 - AT END phrase 244
 - line-sequential files 215
 - multithreading serialization 520
 - QSAM 170
 - VSAM 193
- reading records
 - block size 168
 - from line-sequential files 216
- reading records from VSAM files
 - dynamically 198
 - randomly 198
 - sequentially 198
- reason code from XML parsing 552, 701
- record
 - description 11
 - format
 - fixed-length QSAM 161, 162
 - fixed-length VSAM 192
 - format D 162, 163, 183
 - format F 161, 162, 183
 - format S 164, 165, 166
 - format U 166, 167, 183
 - format V 162, 163, 183
 - QSAM ASCII tape 183

- record (*continued*)
 - format (*continued*)
 - spanned 164, 165, 166
 - undefined 166, 167
 - variable-length QSAM 162, 163
 - variable-length VSAM 192
 - order, effect of organization on 153
- RECORD CONTAINS clause
 - FILE SECTION entry 13
- RECORD KEY clause
 - identifying prime key in KSDS files 188
- RECORDING MODE clause
 - fixed-length records, QSAM 161
 - QSAM files 14
 - specify record format 160
 - variable-length records, QSAM 162, 163
- recursive calls
 - and the LINKAGE SECTION 17
 - coding 487
 - identifying 4
- REDEFINES clause, making a record into a table using 75
- reentrant programs 490
- reference modification
 - example 113
 - expression checking with SSRANGE 361
 - generated XML documents 572
 - intrinsic functions 111
 - national data 112
 - out-of-range values 113
 - tables 71, 112
 - UTF-8 documents 141
- reference modifier
 - arithmetic expression as 114
 - intrinsic function as, example 114
 - variables as 112
- registers used by EXIT compiler option 712
- relation condition 98
- relative file organization 154
- RELEASE FROM statement
 - compared to RELEASE 223
 - example 222
- RELEASE statement
 - compared to RELEASE FROM 223
 - with SORT 222, 223
- REM intrinsic function 62
- RENT compiler option
 - description 352
 - for DLLs 508
 - for IMS 457
 - for Java interoperability 291, 295
 - for OO COBOL 291, 295
 - influencing addressability 41
 - multioption interaction 40, 305
 - performance considerations 670
 - when passing data 41
- REPLACE statement
 - DB2 considerations 449
 - description 383
- replacing
 - data items (INSPECT) 115
 - records in QSAM file 172
 - records in VSAM file 200
- replacing (*continued*)
 - text, DB2 considerations 449
- REPLACING phrase (INSPECT), example 115
- REPOSITORY paragraph
 - class 594
 - client 607
 - coding 5
 - subclass 619
- representation
 - data 54
 - sign 53
- RERUN clause
 - checkpoint/restart 236
- reserved-word table, CICS alternate overview 437
- specifying with WORD 373
- residency mode, definition 40
- restart
 - automatic 655
 - automatic or deferred 651
 - deferred 655
 - overview 651
- restarting a program 654
- restrictions
 - CICS
 - 16 MB line 430
 - calls 431
 - coding 429
 - files 5
 - OUTDD compiler option 348
 - parsing with validation using FILE 541
 - separate translator 435
 - sorting 237
 - DB2 coprocessor 446
 - IMS
 - 16 MB line 430
 - coding 5, 453
 - IMS SQL coprocessor 456
 - input/output procedures 225
 - OO programs 589
 - SQL compiler option 446
 - SQL statements 442
 - SQLIMS compiler option 456
 - subscripting 71
- resubmitting a job 657
- return code
 - compiler
 - depends on highest severity 282
 - effect of message customization 722
 - overview 282
 - feedback code from Language Environment services 680
 - from CICS ECI 433
 - from DB2 SQL statements 445
 - from XML parsing 552, 701
- RETURN-CODE special register 500, 680
- VSAM files
 - description 246
 - example 247
 - RLS mode 208
 - when control returns to operating system 500
- RETURN statement
 - required in output procedure 224
 - with INTO phrase 224
- RETURN-CODE special register
 - calls to Language Environment services 680
 - CICS ECI calls 433
 - considerations for DB2 445
 - not set by INVOKE 611
 - passing data between programs 500
 - sharing return codes between programs 500
 - when control returns to operating system 500
- RETURNING phrase
 - CALL statement 501
 - INVOKE statement 613
 - PROCEDURE DIVISION header 500, 601
- REVERSE intrinsic function 117
- reverse order of tape files 171
- reversing characters 117
- REWRITE statement
 - multithreading serialization 520
 - QSAM 170
 - VSAM 193
- RLS parameter 207
- RMODE
 - description 40
 - of EXIT modules 712
- RMODE compiler option
 - description 353
 - influencing addressability 40
 - multioption interaction 40
 - performance considerations 671
 - when passing data 41
- ROUNDED phrase 686
- rows in tables 69
- RRDS (relative-record data sets)
 - file access mode 191
 - fixed-length records 186, 190
 - organization 190
 - performance considerations 210
 - simulating variable-length records 190
 - variable-length records 186, 190
- RULES compiler option
 - description 354
- run time
 - accessing arguments in z/OS
 - example 505
 - overview 505
 - accessing arguments in z/OS UNIX
 - example 469
 - overview 468
 - changing file-name 9
 - multithreading restrictions 524
 - performance 661
- run unit
 - description 473
 - role in multithreading 518
- running OO applications
 - under z/OS UNIX
 - overview 293
 - XPLINK linkage 299
 - using JCL or TSO/E 296
 - XPLINK linkage 299

- runtime options
 - 85 COBOL Standard
 - conformance 304
 - AIXBLD 673
 - ALL31 479
 - CBLOPTS 505
 - CBLPSHPOP 438
 - CHECK(OFF)
 - performance considerations 671
 - DEBUG 388
 - ENVAR 297
 - MSGFILE 348
 - NOSIMVRD 190
 - POSIX
 - DLL search order 511
 - use in OO applications 297
 - specifying under z/OS 505
 - specifying under z/OS UNIX 463
 - TRAP
 - closing files in QSAM 173
 - closing files in VSAM 200
 - closing line-sequential files 217
 - ON SIZE ERROR 240
 - XPLINK
 - not recommended as a default 299
 - setting 299

S

- S-format record
 - layout 166
 - overview 165
 - requesting 164
- S-level error message 282, 392
- sample programs 805
- scope of names
 - global 486
 - local 486
- scope terminator
 - aids in debugging 386
 - explicit 19, 20
 - implicit 20
- SD (sort description) entry, example 222
- SEARCH ALL statement
 - binary search 87
 - example 88
 - for changing an index 72
 - table must be ordered 87
- search order
 - DLLs in the z/OS UNIX file system 511
- SEARCH statement
 - example 86
 - for changing an index 72
 - nesting to search more than one level of a table 86
 - serial search 86
- searching
 - for name declarations 486
- tables
 - binary search 87
 - overview 85
 - performance 85
 - serial search 86
- section
 - declarative 21

- section (*continued*)
 - definition 18
 - grouping 104
- segmentation 668
- SELECT clause
 - ASSIGN clause 8
 - naming files 8
 - vary input-output file 9
- SELECT OPTIONAL
 - QSAM 171
 - VSAM 196
- SELF 609
- sentence, definition of 18
- separate CICS translator
 - compiler options for 433, 436
 - restrictions 435
 - using 436
- separate sign
 - for line-sequential files 217
 - portability 44
 - printing 44
 - required for signed national decimal 44
- SEQUENCE compiler option 356
- sequential file organization 153
- sequential search
 - description 86
 - example 86
- sequential storage device 154
- serial search
 - description 86
 - example 86
- serialization of files with multithreading 520
- SERVICE compiler option 356
- SERVICE LABEL statement 383
- SET condition-name TO TRUE statement
 - example 102, 104
 - switches and flags 100
- SET statement
 - for changing an index 72
 - for changing index data items 72
 - for function-pointer data items 487
 - for object references 609
 - for procedure-pointer data items 487
 - for setting a condition, example 100
 - handling of program-name in 349
 - using for debugging 388
- setting
 - index data items 72
 - indexes 72
 - switches and flags 100
- sharing
 - data
 - between separately compiled programs 501
 - coding the LINKAGE SECTION 495
 - from another program 16
 - in recursive or multithreaded programs 17
 - in separately compiled programs 16
 - overview 491
 - parameter-passing mechanisms 491

- sharing (*continued*)
 - data (*continued*)
 - passing arguments to a method 611
 - PROCEDURE DIVISION header 496
 - RETURN-CODE special register 500
 - returning a value from a method 613
 - scope of names 486
 - with Java 637
 - files
 - scope of names 486
 - using EXTERNAL clause 12, 501
 - using GLOBAL clause 12
 - short listing, example 397
 - sign condition
 - testing sign of numeric operand 98
 - SIGN IS SEPARATE clause
 - for line-sequential files 217
 - portability 44
 - printing 44
 - required for signed national decimal data 44
 - sign representation 53
 - signature
 - definition of 598
 - must be unique 598
 - signature information bytes
 - compiler options in effect 407
 - DATA DIVISION 407
 - ENVIRONMENT DIVISION 407
 - PROCEDURE DIVISION 407
 - size of printed page, control 172
 - skip a block of records 168
 - softcopy information xviii
 - sort
 - alternate collating sequence 229
 - checkpoint/restart 236
 - completion code 230
 - controlling behavior of 234
 - criteria 227
 - data sets needed under z/OS 226
 - DD statements for defining z/OS data sets 226
 - description 219
 - determining success 230
 - diagnostic message 230
 - FASTSRT compiler option
 - improving performance 231
 - requirements 231
 - using same QSAM file for input and output 232
 - files, describing 221
 - input procedures
 - coding 222
 - example 228
 - keys
 - defining 227
 - overview 220
 - NOFASTSRT compiler option 233
 - output procedures
 - coding 224
 - example 224, 228
 - pass control statements to 235

- sort (*continued*)
 - performance
 - FASTSORT 231
 - variable-length files 226
 - preserving original sequence 230
 - process 220
 - restrictions 219
 - restrictions on input/output
 - procedures 225
 - special registers 234
 - storage use 235
 - terminating 231
 - under CICS 237
 - variable-length records 226
 - work files
 - describing 220
 - workspace 236
- SORT statement
 - ASCENDING | DESCENDING KEY
 - phrase 228
 - COLLATING SEQUENCE phrase 7, 229
 - description 226
 - GIVING phrase 226
 - overview 219
 - restrictions 219
 - restrictions for CICS applications 237
 - under CICS 237
 - change reserved-word table 438
 - USING phrase 226
- SORT-CONTROL special register 234
- SORT-CORE-SIZE special register 234
- SORT-FILE-SIZE special register 234
- SORT-MESSAGE special register 234
- SORT-MODE-SIZE special register 234
- SORT-RETURN special register 234
 - determining sort or merge
 - success 230
 - terminating sort or merge 231
- SORTCKPT DD statement 236
- sorting
 - tables
 - overview 88
- SOURCE and NUMBER output,
 - example 399
- source code
 - compiler data set 269
 - line number 400, 401, 405
 - listing, description 395
 - program listing 274
- SOURCE compiler option
 - description 357
 - getting output 395
- SOURCE-COMPUTER paragraph 5
- SPACE compiler option 357
- spanned files 165
- spanned record format
 - description 164
 - layout 166
 - requesting 164
- special feature specification 5
- special register
 - ADDRESS OF
 - use in CALL statement 492
 - arguments in intrinsic functions 58
 - JNIEnvPtr
 - use for JNI callable services 633
- special register (*continued*)
 - LENGTH OF 122, 492
 - RETURN-CODE 500
 - SORT-RETURN
 - determining sort or merge
 - success 230
 - terminating sort or merge 231
 - using in XML parsing 532, 534
 - WHEN-COMPILED 123
 - XML-CODE 532, 535
 - XML-EVENT 532, 534
 - XML-INFORMATION 532
 - XML-NAMESPACE 532, 538
 - XML-NAMESPACE-PREFIX 533, 538
 - XML-NNAMESPACE 533, 538
 - XML-NNAMESPACE-PREFIX 533, 538
 - XML-NTEXT 532, 537
 - XML-TEXT 532, 537
- special register table 419
- SPECIAL-NAMES paragraph
 - coding 5
 - QSAM files 182
- splitting data items (UNSTRING) 107
- SQL compiler option
 - description 358
 - restrictions
 - compiling in batch 446
 - OO programs 589
 - using 445
- SQL statements
 - CCSID determination 447
 - coding
 - overview 442
 - restriction 442
 - EXIT compiler option and 728
 - overview 441
 - restrictions 442
 - return codes 445
 - SQL DECLARE 443
 - SQL INCLUDE 443
 - use for DB2 services 441
 - using binary data in 445
 - using character data in 443
 - using national decimal data 444
- SQLCA
 - declare for programs that use SQL
 - statements 442
 - declare for programs that use SQLIMS
 - statements 454
 - return codes from DB2 445
- SQLCCSID compiler option
 - description 359
 - effect on CCSID of string data 447
 - performance considerations 448
 - recommended with DB2
 - coprocessor 448
- SQLIMS compiler option 360
 - restrictions
 - compiling in batch 456
 - using 456
- SQLIMS statements
 - coding
 - overview 454
 - EXIT compiler option and 728
 - SQLIMS INCLUDE 454
- SQRT intrinsic function 62
- SSRANGE compiler option
 - description 361
 - performance considerations 671
 - reference modification 113
 - using 391
- STACK runtime option
 - influencing data location 42
 - multioption interaction 40
- STANDARD clause, FD entry 13
- START statement
 - multithreading serialization 520
 - VSAM 193
- statement
 - compiler-directing 20
 - conditional 19
 - definition 18
 - delimited scope 19
 - explicit scope terminator 20
 - imperative 19
 - implicit scope terminator 20
 - nesting level 400
- static calls
 - example 482
 - making 476
 - performance 481
 - with dynamic calls 481
- static data areas, allocating storage 42
- static data, definition of 589
- Static map 417
- static methods
 - definition of 589
 - invoking 624
- statistics intrinsic functions 62
- status code, VSAM files
 - description 246
 - example 247
- stderr
 - controlling line spacing 37
 - directing with DISPLAY 36
 - setting DISPLAY to 465
- stdin
 - reading with ACCEPT 35
- stdout
 - controlling line spacing 37
 - directing with DISPLAY 36
 - setting DISPLAY to 465
- STEPLIB environment variable
 - description 465
 - example of specifying compiler 285
- STGOPT compiler option 362
- STOP RUN statement
 - in main program 474
 - in subprogram 474
 - with multithreading 474
- storage
 - character data 137
 - device
 - direct-access 154
 - sequential 154
 - for arguments 493
 - management with Language
 - Environment callable services 677
 - mapping 395
 - use during sort 235
- stride, table 666
- STRING statement
 - example 106

- STRING statement (*continued*)
 - overflow condition 240
 - using 105
 - with DBCS data 695
 - strings
 - handling 105
 - Java
 - declaring 639
 - manipulating 642
 - null-terminated 496
 - striped extended-format QSAM file 180
 - structure, initializing using INITIALIZE 30
 - structured programming 662
 - structuring OO applications 630
 - subclass
 - coding
 - example 620
 - overview 617
 - instance data 619
 - subprogram
 - and main program 473
 - definition 491
 - description 473
 - linkage 473
 - common data items 494
 - PROCEDURE DIVISION in 496
 - termination
 - effects 474
 - subscript
 - definition 70
 - literal, example 70
 - range checking 391
 - variable, example 70
 - subscripting
 - definition 70
 - example 77
 - literal, example 70
 - reference modification 71
 - relative 71
 - restrictions 71
 - use data-name or literal 71
 - variable, example 70
 - substitution character 132
 - substrings
 - of table elements 112
 - reference modification of 111
 - SUM intrinsic function, example table calculation 89
 - SUPER 614
 - support xviii, 863
 - switch-status condition 98
 - switches and flags
 - defining 99
 - description 99
 - resetting 100
 - setting switches off, example 101
 - setting switches on, example 100
 - testing multiple values, example 100
 - testing single values, example 99
 - SYMBOLIC CHARACTERS clause 8
 - symbolic constant 662
 - syntax diagrams, how to read xvi
 - syntax errors
 - finding with NOCOMPILE compiler option 390
 - SYSABEND file
 - description 268
 - SYSADATA
 - file, creating 271
 - output 305
 - records, exit module 717
 - SYSADATA file
 - description 268
 - example 739
 - file contents 737
 - record descriptions 740
 - record types 738
 - SYSIN data set
 - defining 269
 - description 267
 - SYSJAVA file
 - defining 272
 - description 268
 - SYSLIB data set
 - defining 270
 - description 267
 - when not used 713
 - SYSLIB environment variable
 - description 284
 - specifying location of JNI.cpy 291
 - SYSLIN data set 271
 - description 268
 - SYSMDECK file
 - defining 272
 - description 268
 - SYSMDUMP file
 - description 268
 - SYSOPTF data set
 - defining 269
 - description 267
 - SYSPRINT data set
 - defining 270
 - description 268
 - when not used 716
 - SYSPUNCH data set
 - description 268, 271
 - requirements for DECK compiler option 319
 - system date
 - under CICS 431
 - system dump 239
 - system-determined block size
 - compiler data sets 268
 - QSAM files 168, 310
 - system-name 5
 - SYSTEM data set
 - defining 271
 - description 268
 - sending messages to 363
 - SYSUDUMP file
 - description 268
 - SYSUT data set 267
- T**
- table
 - assigning values to 75
 - columns 67
 - compare to array 39
 - defining with OCCURS clause 67
 - definition 67
 - depth 69
 - description 39
 - dynamically loading 73
 - efficient coding 664, 666
 - elements 67
 - identical element specifications 664
 - index, definition 70
 - initializing
 - all occurrences of an element 76
 - at the group level 76
 - each item individually 75
 - using INITIALIZE 73
 - using PERFORM VARYING 103
 - loading values in 73
 - looping through 103
 - multidimensional 68
 - one-dimensional 67
 - processing with intrinsic functions 89
 - redefining a record as 75
 - reference modification 71
 - referencing substrings of elements 112
 - referencing with indexes, example 70
 - referencing with subscripts, example 70
 - referring to elements 70
 - rows 69
 - searching
 - binary 87
 - overview 85
 - performance 85
 - sequential 86
 - serial 86
 - sorting
 - overview 88
 - stride computation 666
 - subscript, definition 70
 - three-dimensional 69
 - two-dimensional 69
 - variable-length
 - creating 78
 - example of loading 80
 - initializing 81
 - preventing overlay in 84
 - TALLYING phrase (INSPECT), example 115
 - tape files
 - performance 169
 - reverse order 171
 - TERMINAL compiler option 363
 - terminal, sending messages to the 363
 - terminating XML parsing 556
 - termination 474
 - terminology
 - VSAM 185
 - terms used in MAP output 403
 - test
 - conditions 103
 - data 98
 - numeric operand 98
 - UPSI switch 98
 - TEST AFTER 103
 - TEST BEFORE 103
 - TEST compiler option
 - description 364
 - multioption interaction 305

- TEST compiler option (*continued*)
 - performance considerations 671
 - use for debugging 395
- text-name cross-reference,
 - description 394
- text-name environment variable 284
- THREAD compiler option
 - and the LINKAGE SECTION 17
 - cannot use with nested
 - programs 484
 - description 366
 - for Java interoperability 291, 295
 - for OO COBOL 291, 295
 - multioption interaction 305
 - performance considerations 671
- threading
 - and preinitialization 519
 - control transfer 519
 - ending programs 520
 - z/OS UNIX considerations 463
- TITLE statement 383
 - controlling header on listing 5
- top-down programming
 - constructs to avoid 662
- TRACK OVERFLOW option 169
- Trademarks 827
- transferring control
 - between COBOL and non-COBOL
 - programs 473
 - between COBOL programs 475, 483
 - called program 473
 - calling program 473
 - main and subprograms 473
 - nested programs 484
- transforming COBOL data to XML
 - example 578
 - overview 571
- TRAP runtime option
 - closing line-sequential files 217
 - closing QSAM files 173
 - closing VSAM files 200
 - ON SIZE ERROR 240
- TRUNC compiler option
 - description 368
 - performance considerations 671
 - suboptions for separate CICS
 - translator 437
- TSO
 - ALLOCATE command 262
 - CALL command 262
 - compiling under
 - example CLIST 264
 - overview 262
 - SYSTEMM for compiler messages 271
- tuning considerations, performance 668, 669
- typed object references 608

U

- U-format record
 - layout 167
 - requesting 166
- U-level error message 282, 392
- unavailable files
 - QSAM 171
 - VSAM 203

- UNBOUNDED groups
 - processing 90
- undefined record format
 - layout 167
 - QSAM 183
 - requesting 166
 - unfilled tracks 169
- Unicode
 - description 129
 - encoding and storage 137
 - JNI services 642
 - processing data 125
 - using with DB2 443
- universal object references 608
- UNIX
 - calling APIs 466
 - unreachable code 667
- UNSTRING statement
 - example 108
 - overflow condition 240
 - using 107
 - with DBCS data 695
- updating VSAM records 199
- UPPER-CASE intrinsic function 117
- uppercase, converting to 117
- UPSI switches with multithreading 524
- USAGE clause
 - at the group level 25
 - incompatible data 54
 - INDEX phrase, creating index data
 - items with 72
 - NATIONAL phrase at the group
 - level 134
 - OBJECT REFERENCE 608
- USE FOR DEBUGGING declaratives
 - overview 388
- USE statement 384
- user-defined condition 98
- user-exit work area 711
- USING phrase
 - INVOKE statement 611
 - PROCEDURE DIVISION header 496, 601
- UTF-16
 - definition 129
 - encoding for national data 129
- UTF-8
 - avoid INSPECT 551
 - avoid moves that truncate 551
 - avoid reference modification with
 - XML documents 141
 - converting to or from national 141
 - definition 129
 - encoding and storage 137
 - encoding for ASCII invariant
 - characters 129
 - example of generating an XML
 - document 573
 - JNI services 644
 - parsing XML documents 551
 - processing data items 141
 - using intrinsic functions 142
- UTF-8 data
 - using Unicode intrinsic functions 144

V

- V-format record
 - layout 163
 - requesting 162
- validating XML documents
 - example 568
 - overview 540
 - performance considerations 541
 - restrictions 541
- VALUE clause
 - alphanumeric literal with national
 - data, example 121
 - alphanumeric literal with national
 - group, example 76
 - assigning table values
 - at the group level 76
 - to each item individually 75
 - to each occurrence of an
 - element 76
 - assigning to a variable-length
 - group 81
 - cannot use for external floating
 - point 48
 - initializing internal floating-point
 - literals 44
 - large literals with COMP-5 49
 - large, with TRUNC(BIN) 369
- VALUE IS NULL 497
- VALUE OF clause 13
- variable
 - as reference modifier 112
 - definition 23
- variable-length records
 - OCCURS DEPENDING ON (ODO)
 - clause 665
 - QSAM
 - layout 163
 - requesting 162
 - sorting 226
 - VSAM
 - defining 192
 - RRDS 186
- variable-length table
 - assigning values to 81
 - creating 78
 - example 79
 - example of loading 80
 - preventing overlay in 84
- variables, environment
 - example of setting and accessing 466
 - library-name 381
 - runtime 465
- variably located data item 82
- variably located group 82
- VBREF compiler option
 - description 370
 - output example 425
 - using 395
- verb cross-reference listing
 - description 395
- verbs used in program 395
- VLR compiler option
 - description 371
- VSAM files
 - adding records to 199
 - allocating with environment
 - variable 206

VSAM files (*continued*)

- closing 200
- coding input/output statements 193
- comparison of file organizations 187
- creating alternate indexes 204
- DATA DIVISION entries 192
- deleting records from 200
- ENVIRONMENT DIVISION entries 188
- error processing 241
- extended addressability 211
- file position indicator (CRP) 195, 198
- file status key 201
- input/output error processing 201
- loading
 - dynamically or randomly 196
 - extended format 197
 - sequentially 196
 - with access method services 197
- opening
 - empty 196
 - overview 195
- performance considerations 209
- processing files 185
- protecting with password 202
- reading records from 198
- record-level sharing (RLS)
 - error handling 208
 - overview 207
 - preventing update problems 207
 - restrictions 208
- replacing records in 200
- status codes
 - description 246
 - example 247
- under z/OS
 - defining data sets 203
 - file availability 202
 - JCL 206
 - RLS mode 207
- updating records 199

VSAM terminology

- BDAM data set 185
- comparison to non-VSAM terms 185
- ESDS for QSAM 185
- KSDS for ISAM 185
- RRDS for BDAM 185

VSAMOPENFS compiler option 372

W

W-level message 282, 392

WHEN phrase

- EVALUATE statement 95
- SEARCH ALL statement 87
- SEARCH statement 86

WHEN-COMPILED intrinsic function 123

WHEN-COMPILED special register 123

white space in XML documents 548

WITH DEBUGGING MODE clause

- for debugging lines 388
- for debugging statements 388

WITH POINTER phrase

- STRING 105
- UNSTRING 107

WORD compiler option

- description 372
- multioption interaction 305
- recommended for CICS integrated translator 434
- recommended for CICS separate translator 437

work data sets for compiling 267

WORKING-STORAGE SECTION

- client 608, 609
- comparison with LOCAL-STORAGE example 15
- OO client 609
- overview 14
- factory data 622
- instance data 596, 619
- instance method 599
- multithreading considerations 609
- storage location for data 318

workspace

- use during sort 236

wrapper, definition of 630

wrapping procedure-oriented programs 630

Writable static area 417

write a block of records 168

WRITE ADVANCING statement 173

WRITE statement

- line-sequential files 215
- multithreading serialization 520
- QSAM 170
- VSAM 193

X

x suffix with cob2 289

XML declaration

- generating 573
- specifying encoding declaration 549
- white space cannot precede 548

XML document

- accessing 530
- code pages supported 546
- controlling the encoding of 576
- EBCDIC special characters 550
- encoding 546, 547
- enhancing
 - example of modifying data definitions 583
 - rationale and techniques 583
- events
 - example 563
- generating
 - example 578
 - overview 571
- handling parsing exceptions 552
- national language 547
- parser 528
- parsing
 - description 530
 - example 558, 563, 566
 - large documents 545
 - one segment at a time 543
 - UTF-8 551
- parsing with validation
 - example 568
 - overview 540

XML document (*continued*)

- parsing with validation (*continued*)
 - performance considerations 541
 - restrictions 541
- processing 527
- specifying encoding if alphanumeric 549
- white space 548
- XML declaration 548

XML event

CONTENT-CHARACTERS

- example 567
- when parsing segments 544

encoding conflicts 555

END-OF-INPUT

- example 567
- when parsing segments 543

EXCEPTION 554

fatal errors 555

NAMESPACE-DECLARATION 538

overview 534

- processing 528, 532
- processing procedure 530

XML exception codes

- for generating 710
- for parsing 701
- for parsing with XMLPARSE(COMPAT)
 - handleable 703
 - not handleable 707
- for parsing with XMLPARSE(XMLSS) 701

XML GENERATE statement

- COUNT IN 577
- NAME 575
- NAMESPACE 573
- NAMESPACE-PREFIX 574
- NOT ON EXCEPTION 576
- ON EXCEPTION 577
- SUPPRESS 575
- TYPE 575
- WITH ATTRIBUTES 573
- WITH ENCODING 576
- XML-DECLARATION 573

XML generation

- controlling type of XML data 575
- counting generated characters 572
- description 571
- enhancing output
 - example of modifying data definitions 583
 - rationale and techniques 583
- example 578
- generating attributes 573
- generating elements 572
- handling errors 577
- ignored data items 572
- naming attributes or elements 575
- no byte order mark 577
- overview 571
- suppressing generation of specified attributes or elements 575
- using namespace prefixes 574
- using namespaces 573

XML output

- controlling the encoding of 576

- XML output (*continued*)
 - enhancing
 - example of modifying data definitions 583
 - rationale and techniques 583
 - generating
 - example 578
 - overview 571
 - XML PARSE statement
 - NOT ON EXCEPTION 531
 - ON EXCEPTION 531
 - overview 528
 - using 530
 - XML parser
 - error handling 554
 - overview 528
 - XML parsing
 - control flow with processing
 - procedure 535
 - description 530
 - fatal errors 555
 - handling encoding conflicts 555
 - handling exceptions 552
 - one segment at a time
 - example 566
 - overview 543
 - overview 527
 - reason code 552, 701
 - return code 552, 701
 - special registers 532, 534
 - terminating 556
 - with validation
 - example 568
 - overview 540
 - performance considerations 541
 - restrictions 541
 - XML processing procedure
 - control flow with parser 535
 - error with EXIT PROGRAM or GOBACK 533
 - example
 - one segment at a time 566
 - parsing with validation 568
 - program for processing XML 558
 - handling encoding conflicts 556
 - handling parsing exceptions 552
 - multiple segments 543
 - restriction on XML PARSE 533
 - setting XML-CODE in 556
 - specifying 530
 - using special registers 532, 534
 - writing 532
 - XML schemas 542
 - XML-CODE special register
 - content 535
 - continuation after nonzero value 556
 - control flow between parser and processing procedure 535
 - description 532
 - exception codes for generating 710
 - exception codes for parsing 701
 - exception codes for parsing with XMLPARSE(COMPAT)
 - encoding conflicts 553
 - handleable 703
 - not handleable 707
 - XML-CODE special register (*continued*)
 - exception codes for parsing with XMLPARSE(XMLSS) 701
 - fatal errors 555
 - reason code 552, 701
 - return code 552, 701
 - setting to -1 535, 556
 - setting to 1 543
 - subtracting 100,000 from 555
 - terminating parsing 556
 - using in generating 576
 - using in parsing 527
 - with code-page conflicts 555
 - with encoding conflicts 555
 - with generating exceptions 577
 - with parsing exceptions 554
 - XML-EVENT special register
 - content 534, 557
 - description 532
 - using 527, 532
 - with parsing exceptions 554
 - XML-INFORMATION special register
 - content 536
 - description 532
 - XML-NAMESPACE special register
 - content 538
 - description 532
 - using 527
 - XML-NAMESPACE-PREFIX special register
 - content 538
 - description 533
 - using 527
 - XML-NNAMESPACE special register
 - content 538
 - description 533
 - using 527
 - XML-NNAMESPACE-PREFIX special register
 - content 538
 - description 533
 - using 527
 - XML-NTEXT special register
 - content 537
 - description 532
 - using 527
 - with parsing exceptions 554
 - XML-TEXT special register
 - content 537, 557
 - description 532
 - using 527
 - with parsing exceptions 554
 - XMLPARSE compiler option
 - choosing the parser 527
 - description 373
 - XPLINK linkage convention in OO applications 299
 - XPLINK runtime option
 - not recommended as a default 299
 - setting 299
 - XREF compiler option
 - description 374
 - finding copybook data sets 394
 - finding data- and procedure-names 394
 - getting output 395
 - XREF output
 - COPY/BASIS cross-references 422
 - data-name cross-references 421
 - program-name cross-references 422
- ## Z
- z/OS
 - accessing main parameters under
 - example 505
 - overview 505
 - compiling under 255
 - running programs under 505
 - z/OS UNIX
 - accessing environment variables
 - example 466
 - overview 464
 - accessing main parameters under
 - example 469
 - overview 468
 - compiler environment variables 283
 - compiling from script 289
 - compiling OO applications
 - example 293
 - overview 291
 - compiling under 283
 - copybook search order 284, 288, 382
 - copybooks 382
 - developing programs 463
 - execution environments 463
 - linking OO applications
 - example 293
 - overview 292
 - preparing OO applications
 - example 293
 - overview 292
 - programs must be reentrant 490
 - restrictions 463
 - running OO applications
 - overview 293
 - XPLINK linkage 299
 - running programs 463
 - setting environment variables
 - example 466
 - overview 464
 - sort and merge restriction 219
 - specifying compiler options 284
 - z/OS UNIX file system
 - compiler data sets 258
 - defining file with environment variable 157
 - processing files with QSAM 181
 - reading file with ACCEPT 35
 - search order for DLLs in 511
 - writing files with DISPLAY 36
 - zero suppression
 - example of BLANK WHEN ZERO clause 45
 - PICTURE symbol Z 45
 - ZONECHECK compiler option 376
 - zoned decimal data (USAGE DISPLAY) 341, 376, 377
 - effect of ZWB on comparison to alphanumeric 379
 - example 43
 - format 47
 - sign representation 53

ZONEDATA compiler option 377
ZWB compiler option 379



Product Number: 5655-W32

Printed in USA

SC14-7382-03

