

System Automation for OS/390



# Operator's Commands

*Version 2 Release 2*



System Automation for OS/390



# Operator's Commands

*Version 2 Release 2*

**Note!**

Before using this information and the product it supports, be sure to read the general information under "Notices" on page ix.

**Seventh Edition (April 2003)**

This edition applies to System Automation for OS/390 Version 2 Release 2 (5645-006), an IBM licensed program, and to all subsequent releases and modifications until otherwise indicated in new editions or technical newsletters.

Order publications through your IBM representative or the IBM branch office serving your locality. Publications are not stocked at the address given below.

A form for readers' comments appears at the back of this publication. If the form has been removed, address your comments to:

IBM Deutschland Entwicklung GmbH  
Department 3248  
Schoenaicher Strasse 220  
D-71032 Boeblingen  
Federal Republic of Germany

FAX: (Germany): 07031+16-3456

FAX: (Other countries): (+49)+7031-16-3456

Internet e-mail: [s390id@de.ibm.com](mailto:s390id@de.ibm.com)

When you send information to IBM, you grant IBM a nonexclusive right to use or distribute the information in any way it believes appropriate without incurring any obligation to you.

© Copyright International Business Machines Corporation 1996, 2003. All rights reserved.

US Government Users Restricted Rights – Use, duplication or disclosure restricted by GSA ADP Schedule Contract with IBM Corp.

---

# Contents

**Figures . . . . . v**

**Tables . . . . . vii**

**Notices . . . . . ix**

Programming Interface Information . . . . . ix

Trademarks . . . . . x

**About This Book. . . . . xi**

Who Should Use This Book . . . . . xi

Where to Find More Information . . . . . xi

---

**Part 1. Introduction . . . . . 1**

**Introduction . . . . . 3**

Overview of Commands . . . . . 3

Understanding terms . . . . . 3

Format of Syntax Diagrams . . . . . 5

---

**Part 2. SA OS/390 System  
Operations Commands . . . . . 7**

**System Operations Commands. . . . . 9**

Using System Operations Commands . . . . . 9

---

**Part 3. SA OS/390 I/O Operations  
Commands. . . . . 209**

**I/O Operations Commands. . . . . 211**

Using I/O Operations Commands . . . . . 211

FICON Switches . . . . . 211

FICON Cascaded Switches . . . . . 211

ALLOW . . . . . 212

BLOCK . . . . . 214

CHAIN . . . . . 216

CONNECT . . . . . 219

DISCONNECT . . . . . 220

DISPLAY CHP . . . . . 221

DISPLAY DEVICE . . . . . 223

DISPLAY HOST . . . . . 225

DISPLAY NAME . . . . . 227

DISPLAY PORT . . . . . 229

DISPLAY RESULTS . . . . . 231

DISPLAY SWITCH . . . . . 234

DISPLAY TIMEOUT . . . . . 236

DISPLAY VARY . . . . . 236

GETLOCK . . . . . 238

LOGREC . . . . . 238

PROHIBIT . . . . . 239

REMOVE CHP . . . . . 241

REMOVE SWITCH . . . . . 243

RESET HOST . . . . . 245

RESET SWITCH . . . . . 248

RESET TIMEOUT . . . . . 248

RESTORE CHP . . . . . 249

RESTORE SWITCH . . . . . 251

SYNC SWITCH. . . . . 252

UNBLOCK . . . . . 253

UNCHAIN . . . . . 254

UNLOCK . . . . . 256

WRITE . . . . . 257

---

**Part 4. SA OS/390 Processor  
Operations Commands . . . . . 259**

**Using Processor Operations  
Commands . . . . . 261**

General Information . . . . . 261

Host-Based Commands . . . . . 261

Common Commands. . . . . 261

**Common Commands . . . . . 263**

ACTIVATE . . . . . 263

CBU . . . . . 276

DEACTIVATE . . . . . 277

EXTINT . . . . . 281

LOAD . . . . . 283

RESTART. . . . . 288

START . . . . . 289

STOP . . . . . 290

SYSRESET . . . . . 291

**Host-based Commands . . . . . 297**

ISQCCMD . . . . . 297

ISQCHK . . . . . 298

ISQCMON . . . . . 299

ISQEXEC. . . . . 300

ISQHELP. . . . . 301

ISQOVRD . . . . . 303

ISQSEND. . . . . 304

ISQSTART . . . . . 305

ISQSTOP . . . . . 307

ISQVARS. . . . . 308

ISQXCLS . . . . . 318

ISQXDRL. . . . . 319

ISQXDST. . . . . 320

ISQXIII . . . . . 323

ISQXLOC . . . . . 325

ISQXMON . . . . . 326

ISQXOPT. . . . . 328

ISQXUNL . . . . . 330

**Appendix A. Definitions for I/O  
Operations Commands . . . . . 333**

ESCON/FICON Director Switch . . . . . 333

Switch Identifiers . . . . .	333
Logical Switch Number (LSN). . . . .	334
Chain and Unchain a Switchable Path . . . . .	334
Chaining a Path . . . . .	334
When a Command Fails. . . . .	337
A "Partially-ESCON" Path . . . . .	338
Channel Types . . . . .	338
Types Of Channels . . . . .	339
ESCON Channels . . . . .	339
Making Connectivity Changes. . . . .	340
Restore (Enable) a Switch . . . . .	342
Switch Ports. . . . .	342
Logical Tokens . . . . .	342
Allow   Prohibit Mask of a Port . . . . .	342
An ESCON-in-Converted-Mode (CVC) Path . . . . .	343
Physical Tokens . . . . .	343
Using Port Names as a Tool in Switching Commands . . . . .	343
Switch Port Hardware Status on a Display Command . . . . .	344
Remove (Quiesce) a Switch. . . . .	344

Port Switching Commands . . . . .	345
A Parallel Channel in Block (BL) Mode. . . . .	347
Switching Commands . . . . .	348
A Sample Way to Modify a Switch Matrix. . . . .	348
Port Addresses . . . . .	348
Switch Unique Identifier. . . . .	348
Processing a Vary Path Request . . . . .	349
VTAM Application Name . . . . .	350

**Appendix B. General Considerations  
for I/O Operations Commands . . . . . 351**

General Information and Tips for Using Multisystem Commands. . . . .	353
General Considerations for Using the Query Entity   Interface   Relations Commands . . . . .	354

**Glossary . . . . . 357**

**Index . . . . . 377**

## Figures

1. Resource Selection Panel . . . . .	5	46. ENABLE Command Dialog Panel: After Populating . . . . .	88
2. Resource Selection Panel 1 – Non-sysplex-wide	11	47. PATH Dialog Panel . . . . .	88
3. Resource Selection Panel 2 – Sysplex-Wide	12	48. STRUCTURE Dialog Panel . . . . .	89
4. AOCHHELP Command Dialog Panel . . . . .	17	49. INGCICS REQ=CMD Sample Panel . . . . .	94
5. Display of Automation Control File Settings for Subsystem (DISPACF SUBSYSTEM) . . . . .	20	50. INGCICS REQ=BROADCAST Sample Panel	95
6. Automation Operators Panel . . . . .	22	51. INGCICS REQ=INFO Sample Panel . . . . .	95
7. Display of Automation Status File Information for TSO (DISPASF TSO) . . . . .	24	52. INGFILT Command Dialog Panel . . . . .	100
8. DISPASST Command Dialog Panel . . . . .	25	53. INGHG Panel . . . . .	107
9. DISPAUTO Command Dialog Panel . . . . .	29	54. INGHG Check Confirmation Panel . . . . .	109
10. DISPERRS Command Dialog Panel . . . . .	30	55. INGHG line mode output . . . . .	110
11. DISPEVT Command Dialogs Panel - Result	32	56. INGHIST Command Dialog Panel. . . . .	112
12. DISPEVTS Command Dialogs Panel . . . . .	34	57. INGIMS Command Dialog Panel . . . . .	114
13. DISPEVTS Command Dialogs Panel - Action	35	58. INGIMS REQ=BROADCAST Sample Panel	115
14. DISPFLGS Command Dialog Panel of SA OS/390 . . . . .	36	59. INGINFO Command Dialog Panel . . . . .	116
15. DISPGW Command Dialog Panel 1 . . . . .	38	60. INGLIST Command Dialog Panel 1 . . . . .	119
16. DISPGW Command Dialog Panel 2 . . . . .	40	61. INGLIST Command Dialog Panel 2 . . . . .	120
17. DISPGW Command Dialog Panel 3 . . . . .	41	62. INGLKUP Command Dialog Panel . . . . .	123
18. DISPINFO Command Dialog Panel . . . . .	43	63. INGNTFY Command Dialog Panel . . . . .	125
19. INGCICS Command Dialog Panel . . . . .	44	64. INGOPC Command Dialog Panel. . . . .	128
20. Authorized Message Receivers Panel . . . . .	45	65. INGOPC REQ=LIST TYPE=APPL Sample Panel . . . . .	129
21. DISPNTFY Command Dialog Panel . . . . .	47	66. INGOPC REQ=LIST TYPE=OP Sample Panel	129
22. DISPSCHD Command Dialog Panel . . . . .	48	67. INGOPC REQ=LIST TYPE=SR Sample Panel	130
23. DISPSPFLT Sample Panel . . . . .	51	68. INGOPC REQ=LIST TYPE=WS Sample Panel	130
24. Display of Status of All Automated Resources (DISPSTAT) . . . . .	54	69. INGOPC REQ=LIST TYPE=CAL Sample Panel . . . . .	131
25. DISPSTAT Command Dialog Times Panel	55	70. INGOPC Filter Sample Panel . . . . .	131
26. DISPSTAT Command Dialog Description Panel	56	71. INGPLEX selection panel . . . . .	135
27. DISPSPYS Command Dialog Panel . . . . .	57	72. INGPLEX BESTpractices panel. . . . .	136
28. DISPTREE Sample Panel . . . . .	59	73. INGPLEX CDS dialog panel . . . . .	139
29. DISPTRG Command Dialog Panel . . . . .	60	74. Confirmation panel for switching from the current primary CDS to the alternate CDS . . . . .	140
30. Display of Outstanding Replies (DISPWTOR)	62	75. INGPLEX CDS dialog panel after the switch	141
31. EXPLAIN Sample Panel . . . . .	64	76. CFRM couple data set information panel before policy switch . . . . .	141
32. INGAMS Command Dialog Panel 1 . . . . .	67	77. Confirmation panel for policy switch	142
33. INGAMS Command Dialog Panel 2 . . . . .	69	78. Channel path information for CFRM couple data sets . . . . .	142
34. INGAMS Command Dialog Panel 3 . . . . .	70	79. INGPLEX SYSTEM dialog panel . . . . .	144
35. INGAMS Command Dialog Panel 4 . . . . .	70	80. INGPLEX CONS dialog panel . . . . .	145
36. INGCF Selection Panel. . . . .	79	81. INGPLEX IPL main panel . . . . .	148
37. DRAIN Command Dialog Panel: Before any Action . . . . .	82	82. INGPLEX dump options panel. . . . .	149
38. DRAIN Command Dialog: Confirmation Panel for REBUILD . . . . .	82	83. INGPLEX SDUMP panel. . . . .	149
39. DRAIN Command Dialog Panel: After Rebuild	83	84. INGPLEX SDUMP modification panel	150
40. DRAIN Command Dialog Panel: After Forcing	83	85. INGPLEX SVCDUMP target system selection panel . . . . .	151
41. DRAIN Command Dialog Panel: After Draining . . . . .	84	86. INGPLEX SVCDUMP address space selection panel . . . . .	152
42. DRAIN Command Dialog Panel: After Inactivation . . . . .	84	87. INGPLEX SVCDUMP address space detail panel . . . . .	152
43. ENABLE Command Dialog: Panel Before Any Action . . . . .	86	88. INGPLEX SVCDUMP dump option panel	153
44. Confirmation Panel for ENABLE . . . . .	87	89. INGPLEX SLIP main panel . . . . .	154
45. ENABLE Command Dialog: Panel After Enabling . . . . .	87	90. INGRELS Command Dialog Panel . . . . .	156
		91. INGREQ Command Dialog Panel 1 . . . . .	162
		92. INGREQ Command Dialog Panel 2 . . . . .	163

93. INGSCHED Command Dialog Panel 1	168	125. DISPLAY SWITCH Command - Sample 2	236
94. INGSCHED Command Dialog Panel 2	169	126. PROHIBIT Command - Sample 1 . . . . .	241
95. INGSCHED Command Dialog Panel 3	170	127. PROHIBIT Command - Sample 2 . . . . .	241
96. INGSCHED Command Dialog Panel 4	171	128. REMOVE SWITCH Command - Sample	245
97. INGSCHED Command Dialog Panel 5	172	129. RESET HOST Command - Scenario 1	247
98. Display of Threshold Settings for JES (INGTHRES JES) . . . . .	184	130. RESET HOST Command - Scenario 2	247
99. INGTHRES sample panel . . . . .	185	131. UNBLOCK Command - Sample 1. . . . .	254
100. INGTRIG Command Dialog Panel 1 . . . . .	189	132. UNBLOCK Command - Sample 2. . . . .	254
101. INGTRIG Command Dialog Panel 2 . . . . .	190	133. UNCHAIN Command - Sample . . . . .	256
102. INGVOKE Command Dialog Panel . . . . .	192	134. WRITE Command - Sample 1 . . . . .	258
103. INGVIAM REQ=LIST output . . . . .	194	135. WRITE Command - Sample 2 . . . . .	258
104. JES2 DU,ALL Display . . . . .	195	136. ISQXDST Status Summary Panel . . . . .	322
105. SETSTATE Command Dialog Panel . . . . .	205	137. Sample System Options Panel for an OCF-Based Processor in a Basic-Mode MVS Target System . . . . .	329
106. Display of Scheduled Timers (SETTIMER)	206	138. Sample System Options Panel for an OCF-Based Processor in LPAR-Mode MVS Target System . . . . .	329
107. ALLOW Command - Sample 1. . . . .	213	139. Sample of an ESCON Director Diagram	333
108. ALLOW Command - Sample 2. . . . .	214	140. Examples of Chained Paths . . . . .	334
109. BLOCK Command - Sample 1 . . . . .	215	141. Chain - Scenario 1 . . . . .	336
110. BLOCK Command - Sample 2 . . . . .	216	142. Chain - Scenario 2 . . . . .	337
111. CHAIN Command - Sample 1 . . . . .	218	143. ESCON-in-Converted-Mode - Sample	343
112. CHAIN Command - Sample 2 . . . . .	218	144. Switch Port Hardware Status Format	344
113. CONNECT Command - Sample . . . . .	220	145. PROHIBIT Command Example . . . . .	345
114. DISPLAY CHP Command - Sample 1	222	146. CONNECT Command Example . . . . .	345
115. DISPLAY CHP Command - Sample 2	223	147. BLOCK Command Example . . . . .	346
116. DISPLAY DEVICE Command - Sample	225	148. UNBLOCK Command Example . . . . .	346
117. DISPLAY HOST Command - Sample 1	227	149. ALLOW Command Example . . . . .	346
118. DISPLAY HOST Command - Sample 2	227	150. ALLOW Command Example . . . . .	347
119. DISPLAY NAME Command - Sample 1	229	151. Parallel Channel in Block Mode - Sample	347
120. DISPLAY NAME Command - Sample 2	229	152. Switch Unique Identifier Format . . . . .	349
121. DISPLAY PORT Command - Sample	231		
122. DISPLAY RESULTS Command - Scenario 1	232		
123. DISPLAY RESULTS Command - Scenario 2	233		
124. DISPLAY SWITCH Command - Sample 1	235		

---

## Tables

1. System Automation for OS/390 Library	xi	5. ISQVARS Keywords Sorted by Keyword	
2. Related Products Books . . . . .	xii	Name . . . . .	315
3. Overview of Commands . . . . .	3	6. Commands, Their Availability and Access	
4. Profiles and the ACTIVATE Command for		Authorization Levels . . . . .	351
OCF-Based Processors . . . . .	270		



---

## Notices

References in this publication to IBM<sup>®</sup> products, programs, or services do not imply that IBM intends to make these available in all countries in which IBM operates. Any reference to an IBM product, program, or service is not intended to state or imply that only IBM product, program, or service may be used. Subject to IBM's valid intellectual property or other legally protectable rights, any functionally equivalent product, program, or service may be used instead of the IBM product, program, or service. The evaluation and verification of operation in conjunction with other products, except those expressly designated by IBM, are the responsibility of the user.

IBM may have patents or pending patent applications covering subject matter in this document. The furnishing of this document does not give you any license to these patents. You can send license inquiries, in writing, to:

IBM Director of Licensing  
IBM Corporation  
North Castle Drive  
Armonk, NY 10504-1785  
USA

Licensees of this program who wish to have information about it for the purpose of enabling: (i) the exchange of information between independently created programs and other programs (including this one) and (ii) the mutual use of the information which has been exchanged, should contact:

IBM Deutschland Entwicklung GmbH  
Department 3248  
Schoenaicher Strasse 220  
D-71032 Boeblingen  
Federal Republic of Germany

Such information may be available, subject to appropriate terms and conditions, including in some cases, payment of a fee.

Any pointers in this publication to non-IBM web sites are provided for convenience only, and do not in any manner serve as an endorsement of these web sites. IBM accepts no responsibility for the content or use of non-IBM web sites specifically mentioned in this publication or accessed through an IBM web site that is mentioned in this publication.

---

## Programming Interface Information

This book documents information that is NOT intended to be used as a programming interface of System Automation for OS/390<sup>®</sup>.

---

## Trademarks

The following terms, used in this book, are trademarks of the IBM Corporation in the United States or other countries:

CICS	PR/SM
ESCON	RACF
IBM	RMF
IMS/ESA	Sysplex Timer
Micro Channel	S/390
MVS	System/390
MVS/ESA	VTAM
MVS/XA	3090
NetView	
OS/390	

C-bus is a trademark of Corollary, Inc. in the United States, other countries, or both.

Java and all Java-based trademarks are trademarks of Sun Microsystems, Inc. in the United States, other countries, or both.

Microsoft, Windows, Windows NT, and the Windows logo are trademarks of Microsoft Corporation in the United States, other countries, or both.

NetView is a trademark of Tivoli Systems Inc. in the United States, or other countries, or both.

PC Direct is a trademark of Ziff Communications Company in the United States, other countries, or both and is used by IBM Corporation under license.

UNIX is a registered trademark in the United States and other countries licensed exclusively through The Open Group.

---

## About This Book

This document provides detailed information and reference material for operating System Automation for OS/390 (SA OS/390).

Throughout this publication references to MVS<sup>®</sup>, refer either to MVS/ESA<sup>™</sup>, or to the MVS element of OS/390.

---

## Who Should Use This Book

This information is intended primarily for operators and system programmers. It may also be useful for others, for example, help desk personnel and customer engineers.

---

## Where to Find More Information

### The System Automation for OS/390 Library

The following table shows the information units in the System Automation for OS/390 library:

Table 1. System Automation for OS/390 Library

Title	Order Number
<i>System Automation for OS/390 Planning and Installation</i>	SC33-7038
<i>System Automation for OS/390 Customizing and Programming</i>	SC33-7035
<i>System Automation for OS/390 Defining Automation Policy</i>	SC33-7039
<i>System Automation for OS/390 User's Guide</i>	SC33-7040
<i>System Automation for OS/390 Messages and Codes</i>	SC33-7041
<i>System Automation for OS/390 Operator's Commands</i>	SC33-7042
<i>System Automation for OS/390 Programmer's Reference</i>	SC33-7043
<i>System Automation for OS/390 CICS Automation Programmer's Reference and Operator's Guide</i>	SC33-7044
<i>System Automation for OS/390 IMS Automation Programmer's Reference and Operator's Guide</i>	SC33-7045
<i>System Automation for OS/390 OPC Automation Programmer's Reference and Operator's Guide</i>	SC23-7046
<i>System Automation for OS/390 Licensed Program Specifications</i>	SC33-7037

The System Automation for OS/390 books (except Licensed Program Specifications) are also available on CD-ROM as part of the following collection kit:  
IBM Online Library z/OS Software Products Collection (SK3T-4270)

#### SA OS/390 Homepage

For the latest news on SA OS/390, visit the SA OS/390 homepage at <http://www.ibm.com/servers/eserver/zseries/software/sa>

## Related Product Information

The following table shows the books in the related product libraries that you may find useful for support of the SA OS/390 base program.

*Table 2. Related Products Books*

<b>Title</b>	<b>Order Number</b>
<i>ISPF User's Guide</i>	SC34-4484
<i>ISPF Dialog Management Guide and Reference</i>	SC34-4266
<i>MVS/ESA MVS Configuration Program Guide and Reference</i>	GC28-1817
<i>MVS/ESA Planning: Dynamic I/O Configuration</i>	GC28-1674
<i>MVS/ESA Support for the Enterprise Systems Connection</i>	GC28-1140
<i>MVS/ESA Planning: APPC Management</i>	GC28-1110
<i>MVS/ESA Application Development Macro Reference</i>	GC28-1822
<i>OS/390: MVS System Commands</i>	GC28-1781
<i>MVS/ESA SPL Application Development Macro Reference</i>	GC28-1857
<i>OS/390 Hardware Configuration Definition: User's Guide</i>	SC28-1848
<i>OS/390 Information Roadmap</i>	GC28-1727
<i>OS/390 Information Transformation</i>	GC28-1985
<i>OS/390 Introduction and Release Guide</i>	GC28-1725
<i>OS/390 JES Commands Summary</i>	GX22-0041
<i>OS/390 Licensed Program Specifications</i>	GC28-1728
<i>OS/390 Printing Softcopy Books</i>	S544-5354
<i>OS/390 Starting Up a Sysplex</i>	GC28-1779
<i>OS/390 Up and Running!</i>	GC28-1726
<i>Planning for the 9032 Model 3 and 9033 Enterprise Systems Connection Director</i>	SA26-6100
<i>Resource Access Control Facility (RACF) Command Language Reference</i>	SC28-0733
<i>S/390 MVS Sysplex Overview – An Introduction to Data Sharing and Parallelism</i>	GC23-1208
<i>S/390 MVS Sysplex Systems Management</i>	GC23-1209
<i>S/390 Sysplex Hardware and Software Migration</i>	GC23-1210
<i>S/390 MVS Sysplex Application Migration</i>	GC23-1211
<i>S/390 Managing Your Processors</i>	GC38-0452
<i>Tivoli/Enterprise Console User's Guide Volume I</i>	GC31-8334
<i>Tivoli/Enterprise Console User's Guide Volume II</i>	GC31-8335
<i>Tivoli/Enterprise Console Event Integration Facility Guide</i>	GC31-8337
<i>Tivoli NetView for OS/390 Administration Reference</i>	SC31-8222
<i>Tivoli NetView for OS/390 Application Programming Guide</i>	SC31-8223
<i>Tivoli NetView for OS/390 APPN Topology and Accounting Agent</i>	SC31-8224
<i>Tivoli NetView for OS/390 Automation Guide</i>	SC31-8225
<i>Tivoli NetView for OS/390 AON Customization Guide</i>	SC31-8662
<i>Tivoli NetView for OS/390 AON User's Guide</i>	GC31-8661
<i>Tivoli NetView for OS/390 Bridge Implementation</i>	SC31-8238

Table 2. Related Products Books (continued)

Title	Order Number
<i>Tivoli NetView for OS/390 Command Reference Vol. 1</i>	SC31-8227
<i>Tivoli NetView for OS/390 Command Reference Vol. 2</i>	SC31-8735
<i>Tivoli NetView for OS/390 Customization Guide</i>	SC31-8228
<i>Tivoli NetView for OS/390 Customization: Using Assembler</i>	SC31-8229
<i>Tivoli NetView for OS/390 Customization: Using Pipes</i>	SC31-8248
<i>Tivoli NetView for OS/390 Customization: Using PL/I and C</i>	SC31-8230
<i>Tivoli NetView for OS/390 Customization: Using REXX and CLIST Language</i>	SC31-8231
<i>Tivoli NetView for OS/390 Data Mode Reference</i>	SC31-8232
<i>Tivoli NetView for OS/390 Installation: Getting Started</i>	SC31-8767
<i>Tivoli NetView for OS/390 Installation: Migration Guide</i>	SC31-8768
<i>Tivoli NetView for OS/390 Installation: Configuring Graphical Components</i>	SC31-8770
<i>Tivoli NetView for OS/390 Installation: Configuring Additional Components</i>	SC31-8769
<i>Tivoli NetView for OS/390 Messages and Codes</i>	SC31-8237
<i>Tivoli NetView for OS/390 MultiSystem Manager User's Guide</i>	SC31-8607
<i>Tivoli NetView for OS/390 NetView Management Console User's Guide</i>	GC31-8665
<i>Tivoli NetView for OS/390 User's Guide</i>	SC31-8241
<i>Tivoli NetView for OS/390 RODM and GMFHS Programming Guide</i>	SC31-8233
<i>Tivoli NetView for OS/390 Security Reference</i>	SC31-8606
<i>Tivoli NetView for OS/390 SNA Topology Manager and APPN Accounting Manager Implementation Guide</i>	SC31-8239
<i>Tivoli Management Platform Reference Guide</i>	GC31-8324
<i>TSO/E REXX/MVS User's Guide</i>	SC28-1882
<i>TSO/E REXX/MVS Reference</i>	SC28-1883
<i>VM/XA SP GCS Command and Macro Reference</i>	SC23-0433
<i>VSE/SP Unattended Node Support</i>	SC33-6412
<i>VTAM Messages and Codes</i>	SC31-6493
<i>VTAM Network Implementation Guide</i>	SC31-6404
<i>VTAM Network Implementation Guide</i>	SC31-6434

## Using LookAt to look up message explanations

LookAt is an online facility that lets you look up explanations for most messages you encounter, as well as for some system abends and codes. Using LookAt to find information is faster than a conventional search because in most cases LookAt goes directly to the message explanation.

You can access LookAt from the Internet at:

<http://www.ibm.com/eserver/zseries/zos/bkserv/lookat/> or from anywhere in z/OS or z/OS.e where you can access a TSO/E command line (for example, TSO/E prompt, ISPF, z/OS UNIX System Services running OMVS).

The LookAt Web site also features a mobile edition of LookAt for devices such as Pocket PCs, Palm OS, or Linux-based handhelds. So, if you have a handheld device with wireless access and an Internet browser, you can now access LookAt message information from almost anywhere.

To use LookAt as a TSO/E command, you must have LookAt installed on your host system. You can obtain the LookAt code for TSO/E from a disk on your *z/OS Collection* (SK3T-4269) or from the LookAt Web site's **Download** link.

## Accessing z/OS™ licensed documents on the Internet

z/OS licensed documentation is available on the Internet in PDF format at the IBM Resource Link™ Web site at:

<http://www.ibm.com/servers/resourceLink>

Licensed documents are available only to customers with a z/OS license. Access to these documents requires an IBM Resource Link user ID and password, and a key code. With your z/OS order you received a Memo to Licensees, (GI10-0671), that includes this key code.<sup>1</sup>

To obtain your IBM Resource Link user ID and password, log on to:

<http://www.ibm.com/servers/resourceLink>

To register for access to the z/OS licensed documents:

1. Sign in to Resource Link using your Resource Link user ID and password.
2. Select **User Profiles** located on the left-hand navigation bar.

**Note:** You cannot access the z/OS licensed documents unless you have registered for access to them and received an e-mail confirmation informing you that your request has been processed.

Printed licensed documents are not available from IBM.

You can use the PDF format on either **z/OS Licensed Product Library CD-ROM** or IBM Resource Link to print licensed documents.

---

1. z/OS.e™ customers received a Memo to Licensees, (GI10-0684) that includes this key code.

---

## Part 1. Introduction

<b>Introduction</b> . . . . .	<b>3</b>	Subsystem . . . . .	5
Overview of Commands . . . . .	3	Application. . . . .	5
Understanding terms . . . . .	3	Format of Syntax Diagrams . . . . .	5
Resource. . . . .	3		

This part gives an overview of SA OS/390 commands—how to enter them, their format, and the various types of commands.



---

## Introduction

---

### Overview of Commands

Table 3 gives a brief overview of the System Automation for OS/390 commands. This overview describes the various types of commands, their functions and where they can be entered. For detailed information about how to issue commands, refer to *System Automation for OS/390 User's Guide*.

Table 3. Overview of Commands

Type of command	Function	Where entered	Notes
System operations commands			
	Control and maintain resources in the enterprise from a single point of control	NetView console, or NMC	
I/O operations commands			
	Control input/output devices	TSO/ISPF, API, operator console	
Processor operations commands			
	Common commands for automation	API, NetView console, or NMC	Precede with ISQCCMD command
	Control hardware processors	NetView console or NMC	

---

## Understanding terms

### Resource

In SA OS/390 the term resource denotes any automatable entity. The automation manager administers resources. A resource is identified by its name. The resource name must be unique within the automation manager's name space. The format of the resource name is *name/type[/system]*. The three components of the resource name can be the following:

**Name** Specifies the resource or application group.

**Type** The type specifies the type of the resource. The type parameter is optional. It can have the following values:

**APL** Indicates that the resource is a subsystem.

**APG** Indicates that the resource is an application group.

**EVT** Indicates that the resource is an event.

**SVP** Indicates that the resource is a service period (schedule).

**SYG** Indicates all resources of a system. SYG is created automatically. This is the application group which contains all resources of a particular system.

**SYS** Indicates that the resource is a system.

## System

The system name specifies the system where the resource is defined. The system parameter is not used for sysplex application groups.

## Specifying Resources

There are various ways of specifying automation manager resources in System Automation for OS/390. The scope of the automation manager is a sysplex.

### Using Fragments:

Here are a few examples of how to specify resources using fragments:

**TSO** All resources that have the name TSO.

#### **TSO/APG**

All resources that have the name TSO, and the type APG.

#### **TSO/APL**

All resources that have the name TSO, of the type APL, on all systems in the sysplex.

### Using Wildcards:

You can also use an asterisk (\*) to substitute one or more fragments of a fully qualified resource name. Here are a few examples of how to specify resources using wildcards:

#### **\*/APL/SYS1**

All resources of type APL, on system SYS1.

#### **TSO\*/SYS1**

All resources that have the name TSO, of any type, on system SYS1.

#### **\*/SYS/\***

All resources of type SYS, on any system in the sysplex.

#### **\*/\*/\***

All resources of any type on any system in the sysplex.

You can specify wildcards for a fragment of the fully qualified resource name as a leading or trailing character. The following shows a few examples:

#### **TSO\*/APL/KEY\***

All resources starting with TSO, of type APL, on the systems whose names start with KEY.

#### **\*TSO/AP\*/\***

All resources whose names end with TSO, of any type starting with AP, on any system in the sysplex.

You can use % as a placeholder for one character which means that any character in that position of the resource name matches. The following shows a few examples:

#### **%TSO\***

All resources whose names contain TSO starting in character two.

#### **TSO/S%S/\***

All resources whose names start with TSO and where the first and last character of the type is S, on any system in the sysplex.

If the resource that you specified is not unique within the domain of the automation manager, a selection panel is displayed where you can select what you want to work with:

```

AOFKSEL4          SA OS/390 - Command Dialogs      Line 1 of 4
Domain ID = IPSNO ----- INGINFO -----         Date = 02/24/00
Operator ID = NETOP1                                Time = 11:12:00

Multiple instances found for TSO
Select one item to be processed, then press ENTER.

Sel  Name          Type System      Description
-----
     TSO           APL KEY1        Time Sharing Option
     TSO           APL KEY2        Time Sharing Option
     TSO           APL KEY3        Time Sharing Option
     TSO           APL KEY4        Time Sharing Option

Command ==>
PF1=Help      PF2=End      PF3=Return
PF6=Roll
                                           PF12=Retrieve

```

Figure 1. Resource Selection Panel

## Subsystem

The automation agent administers subsystems. A subsystem is also a resource, as for example in an application group. A subsystem always leads to a resource like *name/APL/system*. For further information on subsystems in SA OS/390, refer to *System Automation for OS/390 User's Guide*.

## Application

An application is an OS/390 subsystem, started task, batch job or non-MVS resource that runs on a system in the SA OS/390 enterprise. An application cannot be linked to a system directly. It must be defined as part of an application group, and it may belong to more than one application group. For further information on how to define an application to SA OS/390, refer to *System Automation for OS/390 Defining Automation Policy*.

---

## Format of Syntax Diagrams

The description of each command and routine includes the format of the command in a syntax diagram. The diagram shows the operands for the commands. Use blanks to separate the operands, unless otherwise stated or diagrammed.

To construct a command from the diagram, follow the diagram from left to right, choosing the path that suits your needs. Following is a sample syntax diagram that explains how to construct a command. This sample command is for illustration only.

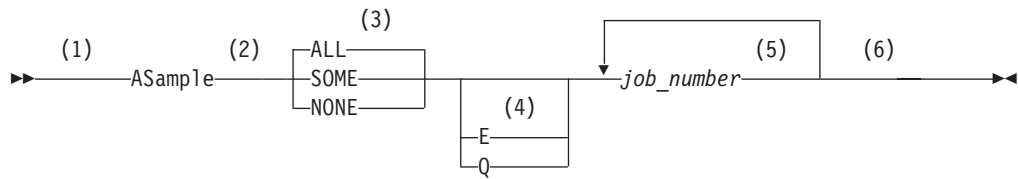

**Notes:**

- 1 Start here. ►► indicates the start of the diagram.
- 2 You can type ASAMPLE or abbreviate it to AS. The uppercase characters are the abbreviation. Operands on the main line are required.
- 3 Choose one of the options. The default is always above the main line. In this case, ALL is the default. If the option includes punctuation marks, include them too: =(), .
- 4 Choose E, Q, or neither. Operands below the main line are optional.
- 5 Repeat *job\_number* any number of times. Variables are shown in italics. Replace them with a real name or value. Note that if you specify more than one *job\_number* you must put them in brackets.
- 6 End here. ►► indicates the end of the command.

If a command continues to the next line, you see ► and ►.  
 {and} indicates a fragment for a specific condition or option.

**Examples:**

```
====> asample none q DAF00821 DAF00832 ELD00824
====> as some DLR01445
```

## Part 2. SA OS/390 System Operations Commands

<b>System Operations Commands</b> . . . . .	9	INGCF . . . . .	73
Using System Operations Commands . . . . .	9	INGCFL . . . . .	91
General Information . . . . .	9	INGCICS . . . . .	92
Overview of Commands that Operate		INGEVENT . . . . .	95
Sysplex-Wide . . . . .	9	INGFILT . . . . .	97
Additional Parameters for System Operations		INGGROUP . . . . .	100
Commands . . . . .	10	INGHC . . . . .	103
Deciding the Format of the Command Output		INGHIST . . . . .	110
(Full-Screen only) . . . . .	13	INGIMS . . . . .	112
ACF . . . . .	14	INGINFO . . . . .	115
AOCHHELP . . . . .	16	INGLIST . . . . .	117
AOCTRACE . . . . .	17	INGLKUP . . . . .	121
DISPACF . . . . .	19	INGNTFY . . . . .	123
DISPAOPS . . . . .	20	INGOPC . . . . .	125
DISPASF . . . . .	22	INGPLEX . . . . .	132
DISPASST . . . . .	24	INGRELS . . . . .	154
DISPAUTO . . . . .	26	INGREQ . . . . .	156
DISPERRS . . . . .	29	INGRPT . . . . .	163
DISPEVT . . . . .	31	INGSCHED . . . . .	165
DISPEVTS . . . . .	33	INGSEND Using RMTCMD . . . . .	172
DISPFLGS . . . . .	35	INGSEND Using Gateway Sessions . . . . .	175
DISPGW . . . . .	37	INGSET . . . . .	178
DISPINFO . . . . .	42	INGTHRES . . . . .	181
DISPMSGGS . . . . .	44	INGTIMER . . . . .	185
DISPNTFY . . . . .	46	INGTOPO . . . . .	187
DISPSCHD . . . . .	47	INGTRIG . . . . .	188
DISPSFLT . . . . .	49	INGVOTE . . . . .	190
DISPSTAT . . . . .	51	INGVTAM . . . . .	193
DISPSYS . . . . .	56	JES2 . . . . .	194
DISPTREE . . . . .	58	MONITOR . . . . .	195
DISPTRG . . . . .	59	RESTART . . . . .	196
DISPWTOR . . . . .	61	RESYNC . . . . .	197
DRAINJES . . . . .	62	SETASST . . . . .	198
EXPLAIN . . . . .	63	SETHOLD . . . . .	201
GWTRACE . . . . .	64	SETSTATE . . . . .	202
INGAMS . . . . .	65	SETTIMER . . . . .	205
INGAUTO . . . . .	71		

This part describes SA OS/390 system operations commands - their format, and specifics of how to use them.

Refer to *System Automation for OS/390 User's Guide* for general information about the SA OS/390 commands.



---

# System Operations Commands

---

## Using System Operations Commands

### General Information

You can issue any system operations command by typing the command and its parameters on the command line of any NetView or system operations panel. You can also issue system operations commands by entering the command via NMC. In addition, System Automation for OS/390 provides a menu of command dialogs which allows you to select a command dialog panel for a specific system operations command. For further information on how to issue system operations commands, refer to *System Automation for OS/390 User's Guide*.

### Overview of Commands that Operate Sysplex-Wide

The following lists the sysplex-wide commands:

- DISPEVTS
- INGAMS
- INGCF
- INGCICS
- INGEVENT
- INGHC
- INGHIST
- INGIMS
- INGINFO
- INGLIST
- INGOPC
- INGPLEX
- INGRELS
- INGREQ
- INGSCHED
- INGSET
- INGTRIG
- INGVOTE
- INGVTAM

You can issue sysplex-wide commands from any system within the sysplex, regardless of where the resource resides.

If no target is specified the command that was issued will find the affected resources in the sysplex.

Specifying the target system parameter is only required when routing the command from the focal-point system to a system in another sysplex or to a single remote system.

For further information about sysplex-wide commands, refer to *System Automation for OS/390 User's Guide*.

## Additional Parameters for System Operations Commands

### Additional Parameters for System Operations Commands

The following parameters are available for a number of system operations commands:

#### TARGET

The TARGET parameter lets you specify the system where the command is to be processed. You can direct the command to:

- A particular system in the sysplex, or enterprise
- A subset of systems in the sysplex, or enterprise
- A sysplex
- All systems currently active in the local sysplex

The syntax is as follows:

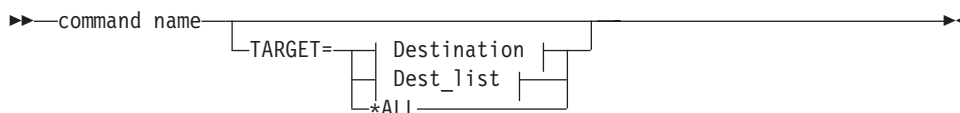

#### Destination:



#### Dest\_list:



Where:

*system\_name*

Specifies the name of the OS/390 system

*domain\_ID*

Specifies the NetView domain identifier

*sysplex\_name*

Specifies the name of the sysplex

**\*ALL** SA OS/390 specifies that the command should be routed to all SA OS/390 systems that are currently active in the local sysplex.

Note, that not all of the commands that support the TARGET parameter also support the \*ALL value. Refer to the respective syntax diagrams for information about whether \*ALL is supported.

The search sequence is as follows:

1. System name within the local sysplex
2. Domain ID within the local sysplex
3. Local sysplex name

If it is a human operator, the search continues in the following sequence:

- Domain ID within the enterprise
- System name within the enterprise

## Additional Parameters for System Operations Commands

- Sysplex name within the enterprise

If no value is specified, and the command does not refer to a defined resource, it is processed on the local system.

**Note:** The following only applies to commands that do **not** operate sysplex-wide.

If you do not specify the TARGET parameter, and the SA OS/390 command refers to a defined resource, SA OS/390 processing is as follows:

- If the resource is only defined on one active system, the command is routed to that specific system.
- If it is an autotask, or when processing the command in line mode, SA OS/390 checks whether or not the resource is defined on the local system. If it is, the command is processed locally. Otherwise, an error message is issued.
- If the resource is defined on more than one active system, and the command is not running on an autotask, SA OS/390 displays the following selection panel where you can select the resource, or resources where the command is to be routed to:

If you type `dispacf mvsesa` a panel similar to the following is displayed:

```
A0FKSEL1                SA OS/390 - Command Dialogs          Line 1 of 4
Domain ID = IPUFA      ----- DISPACF -----          Date = 06/27/00
Operator ID = NETOP1                                     Time = 17:43:12

Multiple instances found for MVSESA in sysplex(es) AOCPLX
Select one or more items to be processed, then press ENTER.

  Sel  System  Domain
  ---  -
      AOCA   IPUFA
      AOCC   IPUFC
      AOCD   IPUFD

Command ==>
PF1=Help   PF2=End   PF3=Return
PF6=Roll                                     PF12=Retrieve
```

*Figure 2. Resource Selection Panel 1 – Non-sysplex-wide*

If the target is within the local sysplex, the communication method is via XCF facilities. Otherwise, the NetView RMTCMD (LU 6.2) command is used. Sysplex-wide commands are processed locally.

**Note:** The following only applies to sysplex-wide commands.

If a target is specified and the resource is not defined on the specified system, SA OS/390 issues an error message.

If you type `ingvote stdt000*` a panel similar to the following is displayed:

## Additional Parameters for System Operations Commands

```

A0FKSEL4          SA OS/390 - Command Dialogs          Line 1 of 32
Domain ID = IPUFA  ----- INGVOTE -----            Date = 06/27/00
Operator ID = NETOP1                                Time = 17:50:39

Multiple instances found for STDT000*
Select one item to be processed, then press ENTER.

Sel  Name          Type System      Description
---  -
      STDT000AN00  APL  AOCA        Parent for all STD* appl 05/16/00 06:25
      STDT000AN00  APL  AOCC        Parent for all STD* appl 05/16/00 06:25
      STDT000AN00  APL  AOCC        Parent for all STD* appl 05/16/00 06:25
      STDT000AN00  APL  AOCD        Parent for all STD* appl 05/16/00 06:25
      STDT000AN1A  APL  AOCA        Child of AN10 (child tree --- AN1B)
      STDT000AN1A  APL  AOCC        Child of AN10 (child tree --- AN1B)
      STDT000AN1A  APL  AOCC        Child of AN10 (child tree --- AN1B)
      STDT000AN1A  APL  AOCD        Child of AN10 (child tree --- AN1B)
      STDT000AN1B  APL  AOCA
      STDT000AN1B  APL  AOCC
      STDT000AN1B  APL  AOCC

Command ==>
PF1=Help      PF2=End      PF3=Return
PF6=Roll      PF8=Forward  PF12=Retrieve
  
```

Figure 3. Resource Selection Panel 2 – Sysplex-Wide

### OUTMODE

This parameter lets you specify the output mode of a command. If you specify **LINE**, the output is displayed in line mode, independent of the task type.

The syntax is as follows:



Further characteristics are the following:

- No color attributes are set for data that is shown in line mode.
- The sequence of the fields may be different in line mode than in fullscreen.
- Not all fields from the fullscreen display may be shown in line mode.
- Line mode output is shown in a multiline message.
- Line mode output is not processed by the message automation table and is not written to the netlog. To obtain output from a command such as **DISPSTAT** in the netlog, use a **PIPE** command, for example:  
`PIPE NETV DISPSTAT OUTMODE=LINE | LOGTO NETLOG`
- Line mode output cannot be processed by a **TRAP** and **WAIT**.
- System operations commands can be issued within a NetView **PIPE** by using the **OUTMODE=LINE** parameter, unless noted otherwise in the command description.
- System operations commands supporting the **OUTMODE=LINE** option can be used in user-written clists. Note however, that the format of the output may change for follow-on Releases.
- If you work with **OUTMODE=LINE** no prompt panel is displayed.
- If no value is specified, the decision whether to display the command output by means of a full-screen panel or in line mode is based on the NetView task type the command is running on.

### OUTDSN

This parameter lets you specify the name of the data set that is to contain the

## Additional Parameters for System Operations Commands

output of the command. You can specify a sequential data set or a member of a partitioned data set. The minimum record length is 80 bytes, except for the DISPSTAT and INGLIST commands where the minimum record length is 256 bytes. The data set must already exist. The OUTDSN parameter forces OUTMODE=LINE.

### Deciding the Format of the Command Output (Full-Screen only)

Most of the automation manager commands support the SORT and FIND subcommands.

#### Sorting a List

The SORT subcommand lets you display a list ordered according to certain criteria. You can specify the following:

##### sort\_order

Specifies the sort order. It can be one of the following:

**A** The list is displayed in ascending order. This is the default.

**D** The list is displayed in descending order.

**coln** Specifies the column to be sorted. More than one column can be specified separated by a comma or a blank.

For example, specifying SORT D,3 1 4 sorts the display in descending sequence and in the order column 3, 1 and 4.

The syntax of the SORT subcommand is as follows:



#### Searching for Strings

The FIND subcommand searches the display data for the specified string. It can be abbreviated to F. The RFIND (repeat find) command is used to find the next occurrence of the string in the display data. It can be abbreviated to RF. With the FIND and RFIND commands you can specify the following parameters:

##### searchstring

Specifies the string to be searched for. The search starts at the first line shown in the display.

##### direction

Specifies the direction used for the search. The direction can be:

**Next** Forward direction. This is the default. It can be abbreviated to N.

##### Previous

Backward direction. It can be abbreviated to P.

The syntax of the FIND subcommand is as follows:



## ACF

### Purpose

The ACF command is used to load automation control file data. You can use ACF to refresh data of a particular system if it does not affect automation manager configuration data.

### Recommendation

Use the INGAMS command rather than the ACF command to load or refresh an automation control file. Thus, you can make sure that the configuration matches the automation manager and the automation agents.

### Syntax

The following syntax diagrams show how to use the ACF command to perform the different functions ACF supports. Do not combine syntax from the separate diagrams in the same ACF call.

Use the following syntax to:

- Load an automation control file
- Load and save an automation control file using the NetView save/restore facility for subsequent warm starting

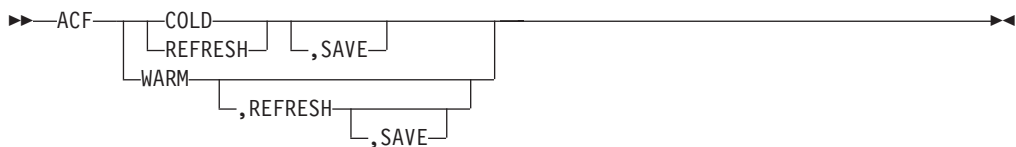

To display the status of the automation control file use the following syntax:

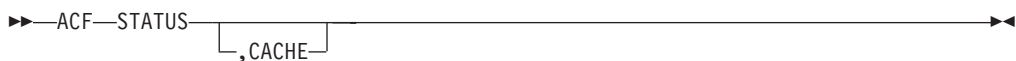

To save the current automation environment using the NetView Save/Restore facility for subsequent warm starting, use the following syntax:



### Parameters

#### CACHE

Displays information about the ACF that is currently stored in the NetView save/restore database

#### COLD

Reloads the currently loaded automation control file data from disk. Automation is disabled while the automation control file load is performed.

#### WARM

Restores automation control file data from cache. Automation is disabled while the automation control file load is performed.

#### REFRESH

Updates the currently loaded automation control file data. Automation is not

disabled while the automation control file load is performed. Only data that has been changed will be loaded, everything else remains the same as before. This is the safe way to update the automation control file. Refresh will not load data of a subsystem that is currently in the process of being started or stopped by SA OS/390. SA OS/390 will automatically retry the refresh five minutes later for the data that can currently not be processed.

**Note:** INGAMS REFRESH will not delete globals that were associated with ENTRY TYPEs that were deleted from the policy database before the last build was done if those ENTRY TYPEs were not associated with a subsystem. However, if a keyword/value is removed from the ENTRY TYPE, this is a change to the ENTRY TYPE, and consequently an INGAMS REFRESH will rebuild the ENTRY TYPE with the result that the deleted keyword/value pair is removed from the globals. All deleted entry types and their associated globals will be reset during the next SA OS/390 COLD start or during ACF COLD processing.

### SAVE

The SAVE parameter will save the current automation environment using the NetView SAVE/RESTORE facility. The saved automation environment is used for future WARM starting.

### STATUS

Displays information about the current in-storage automation control file.

### Restrictions and Limitations

- If you use COLD/WARM, automation is disabled while the ACF LOAD is in progress. If you use REFRESH, automation continues.
- An automation control file cannot be loaded by an operator using the ACF command if the automation flag for major resource MVSESA is set to 'N'. If the automation flag for MVSESA.RELOAD.CONFIRM minor resource is set to 'Y', the operator can reload the ACF.
- ACF must comply with the automation manager configuration. Otherwise, message AOF618I is issued.

### Usage

- ACF performs two flag checks when the automation control file is reloaded, restored or saved. The checks are of the Automation flags for MVSESA.RELOAD.CONFIRM and MVSESA.RELOAD.ACTION. The action flag is checked only if the reload, restore or save is to continue.

#### MVSESA.RELOAD.CONFIRM

This lets you:

- Turn the flag off and thus disable an automation control file reload by an operator.
- Tell SA OS/390 to ask for confirmation by setting the AOFCONFIRM TGLOBAL to YES in a flag exit
- Use a flag exit to perform additional checks and processing before deciding to either cancel or proceed with the reload or restore.

If the flag is found to be off, the operator cannot reload or restore the automation control file.

**Note:** You need to be aware of this if you turn the MVSESA automation flag off.

## ACF

If the flag is on, the AOFCONFIRM task global is checked. If it is set to YES, then SA OS/390 will post a message requesting confirmation of the reload or restore request. If AOFCONFIRM is null, SA OS/390 will proceed with the reload or restore.

### MVSESA.RELOAD.ACTION

This provides an opportunity for you to do your own processing once SA OS/390 is committed to reloading or restoring the automation control file. You can use a flag exit to call your own code. Your exit should return 0, indicating that the flag is turned on. If you return a non-zero return code, subsequent exits defined for the flag will not be invoked. Note that there is no way of preventing the reload or restore from an exit on this flag. Refer to *System Automation for OS/390 Defining Automation Policy* and to *System Automation for OS/390 Customizing and Programming* for further information.

## Messages

The following is a list of messages that are issued during the operation of ACF.

For the load function (COLD/REFRESH/WARM):

```
AOF042I MEMBER ACFZ999 NOT FOUND
AOF100I 16:05:09 : 'ACF REFRESH' COMMAND ISSUED
AOF618I NO VALID ACF FOUND FOR sysname - detail description
AOF782I AUTOMATION CONTROL FILE PROCESSING COMPLETED
```

For the status function (STATUS):

```
AOF005I MEMBER ACFZ999 CURRENTLY BEING USED FOR THE CONTROL FILE
AOF006I BUILT      BY opid      ON 02/22/00 AT 18:05:17
AOF006I REFRESHED BY opid      ON 03/09/00 AT 16:42:51
AOF006I CONFIGURATION TOKEN   = 200002221801085A0345229673
AOF006I CONFIGURATION DATASET = AOC.GDGS.ACF.G0007V00
AOF002I END OF MULTI-LINE MESSAGE GROUP
```

For the status function (STATUS,CACHE):

```
AOF005I MEMBER ACFZ999 CURRENTLY BEING SAVED IN THE CACHE
AOF006I BUILT      BY opid      ON 02/22/00 AT 18:05:17
AOF006I SAVED     BY opid      ON 03/09/00 AT 16:42:51
AOF006I CONFIGURATION TOKEN   = 200002221801085A0345229673
AOF006I CONFIGURATION DATASET = AOC.GDGS.ACF.G0007V00
AOF002I END OF MULTI-LINE MESSAGE GROUP
```

## AOCHELP

### Purpose

AOCHELP displays information on system automation commands, and enables you to execute them.

### Syntax

```
➔➔ AOCHELP commandname ➔➔
```

### Parameters

*commandname*

Specifies the SA OS/390 system operations command that you require information about. The result is the same as if you specify help *commandname*.

### Restrictions and Limitations

- Some commands may not be executed from the AOCHELP command dialog. Attempts to execute these commands produce SA OS/390 message AOF129I.
- Help is available only in full-screen mode.
- The AOCHELP command can only be used when SA OS/390 has initialized.

### Usage

If you type aochelp by itself, you see a list of commands to choose from.

From this panel you can ask for help on a command by entering its item number.

### Examples

To get help, specify the associated number of the command.

```

AOFPH000          SA OS/390 - Command Dialogs          Line 1 of 63
Domain ID   = IPUFA          ----- AOCHELP -----          Date = 06/27/02
Operator ID = NETOP1                                     Time = 15:06:59

      1 AOCHELP          Display help for SA OS/390 commands
      2 AOCTRACE         Control the SA OS/390 internal trace
      3 ASSIST           Test subsystem automation
      4 CROSS DOMAIN    Dealing with other domains
      5 DISPACF         Display control file information
      6 DISPAOPS        Display automated operator information
      7 DISPASF         Display status file information
      8 DISPASST        Display assist settings
      9 DISPAUTO        Display couple data set information
     10 DISPERRS        Display error information
     11 DISPEVT         Display event information
     12 DISPEVTS        Display all events in a Sysplex
     13 DISPFLGS        Display automation flag information
     14 DISPGW          Display NNT gateway information

Enter n for help or nX to execute the command (if possible).

Command ==>
  PF1=Help      PF2=End      PF3=Return      PF6=Ro11
                PF8=Forward   PF12=Retrieve
    
```

Figure 4. AOCHELP Command Dialog Panel

To execute the command, specify the number associated with the command followed by an x, for example, 9x.

## AOCTRACE

### Purpose

The AOCTRACE command turns the SA OS/390 system operations debugging feature on or off. It works with both a global debugging feature, and two automation procedure (REXX EXEC) specific ones.

### Syntax

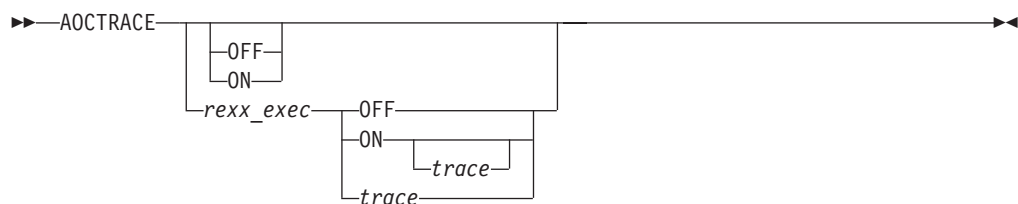

## AOCTRACE

### Parameters

*rexx\_exec*

The name of the REXX EXEC you want to debug.

#### ON

Turns the debugging feature on.

If you do not specify a REXX EXEC, AOCTRACE activates a global debugging flag. This causes each SA OS/390 system operations REXX EXEC that is invoked to write a record to the netlog showing the parameters it was invoked with.

If you do specify a REXX EXEC, only that REXX EXEC writes messages to the netlog. The netlog shows when and where the REXX EXEC was called, and what parameters were given.

If you specify a REXX EXEC but not a trace, an intermediate level of debugging is activated for the specified REXX EXEC. This causes the REXX EXEC to issue a number of messages describing its actions. Note, however, that not all REXX EXECs support this facility.

#### OFF

Turns the debugging feature off.

If a REXX EXEC is specified, this option deactivates both the intermediate and REXX tracing for the specified REXX EXEC.

If a REXX EXEC is not specified, this option disables the global trace.

*trace*

The type of REXX trace that you want for the specified REXX EXEC. Valid values are:

<b>A</b>	All
<b>R</b>	Results
<b>I</b>	Intermediates
<b>C</b>	Commands
<b>E</b>	Errors
<b>F</b>	Failures
<b>L</b>	Labels
<b>O</b>	Off
<b>N</b>	Normal

### Restrictions and Limitations

The trace operand can only be used on interpreted REXX EXECs.

Using the trace on certain REXX EXECs can cause execution problems, particularly in REXX EXECs which trap messages.

The REXX trace setting of S (Scan) is not available.

**Note:** The debugging facility is not active if REXX trace A, R, or I are used.

### Examples

If you type `aoctrace` on you see a message indicating that the debugging facility is enabled. While the debugging facility is enabled, message AOF700I is written to the netlog for each procedure being processed.

For further information on how to use the AOCTRACE command refer to the Appendix on "Problem Determination" in *System Automation for OS/390 User's Guide*.



## DISPACF

### Examples

If you type dispacf subsystem, you see a full-screen display similar to the following:

```
AOFK3D0X          SA OS/390 - Command Response      Line 1   of 893
Domain ID   = IPSNO   ----- DISPACF -----      Date = 07/19/00
Operator ID = NETOP1                               Time = 18:38:13

Command = ACF ENTRY=SUBSYSTEM,TYPE=*,REQ=DISP
SYSTEM = KEY3      AUTOMATION CONFIGURATION DISPLAY - ENTRY= SUBSYSTEM
-----
AUTOMATION CONFIGURATION DISPLAY - ENTRY= SUBSYSTEM
TYPE IS ALLOCAS
JOBTYPE      = MVS
RESTARTOPT   = ALWAYS
SHUTDLY      = 00:01:00
STRTDLY      = 00:02:00
TERMDLY      = 00:00:12
EXTSTART     = ALWAYS
EXTSTOP      = ALWAYS
JOB          = ALLOCAS
SCHESUB      = MSTR
SDESC       = 'MVS ADDRESS SPACE'
TYPE IS AMCP
IPOPTIONS    = NOSTART
PARMS       = ',RUN=3'
PROCNAME     = AAAZTSEM
JOB         = AMCP
JOBTYPE      = TRANSIENT
OBJECTCLASS  = JES2_TRANS
PARENT       = (JES2)
SDESC       = 'SIMULATED SUBSYSTEM'
TRANRERUN   = NO
TYPE IS ANTMAIN
JOBTYPE      = MVS
RESTARTOPT   = ALWAYS
SHUTDLY      = 00:01:00
STRTDLY      = 00:02:00
TERMDLY      = 00:00:12
EXTSTART     = ALWAYS
EXTSTOP      = ALWAYS
JOB         = ANTMAIN
SCHESUB      = MSTR

Command ==>
PF1=Help      PF2=End      PF3=Return      PF6=Ro11
               PF8=Forward  PF9=Refresh     PF12=Retrieve
```

Figure 5. Display of Automation Control File Settings for Subsystem (DISPACF SUBSYSTEM)

This command displays information for all types of the SUBSYSTEM entry, since you accepted the default TYPE=\*.

If you type dispacf subsystem jes2, you see only information on the JES2 type.

## DISPAOPS

### Purpose

The DISPAOPS command displays a list of automation operators that are currently active.

### Syntax

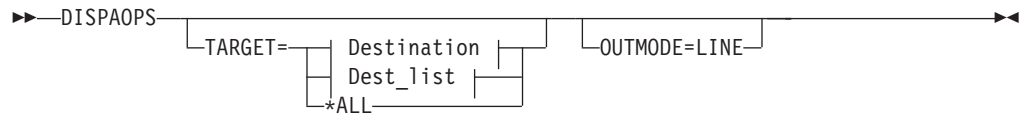
**Destination:****Dest\_list:****Parameters****TARGET**

For information on the TARGET parameter, refer to “Additional Parameters for System Operations Commands” on page 10.

**OUTMODE**

For information on the OUTMODE parameter, refer to “Additional Parameters for System Operations Commands” on page 10.

**Restrictions and Limitations**

The DISPAOPS command can only be used when SA OS/390 is initialized.

**Examples**

Type `dispaops` on any command line and press the ENTER key. You see a panel similar to the following:

## DISPAOPS

```

AOFK2SO          SA OS/390 - Command Dialogs          Line 1   of 20
Domain ID   = IPUF9          ----- DISPAOPS -----          Date = 12/17/97
Operator ID = NETOP1                                     Time = 15:19:59

System      Automated
-----      -Function-----
AOC9      GATOPER      GATIPUF9      ACTIV
AOC9      AOFWRK01     AUTWRK01     ACTIV
AOC9      AOFWRK02     AUTWRK02     ACTIV
AOC9      AOFWRK03     AUTWRK03     ACTIV
AOC9      AOFWRK04     AUTWRK04     ACTIV
AOC9      AOFWRK05     AUTWRK05     ACTIV
AOC9      BASEOPER     AUTBASE      ACTIV
AOC9      SHUTOPER     AUTSHUT      ACTIV
AOC9      MONOPER     AUTMON       ACTIV
AOC9      GSSOPER     AUTGSS       ACTIV
AOC9      MVSCONS     AUTCON       ACTIV
AOC9      MSGOPER     AUTMSG       ACTIV
AOC9      NETOPER     AUTNET1      ACTIV      AUTNET2      ACTIV
AOC9      JESOPER     AUTJES       ACTIV
AOC9      SYSOPER     AUTSYS       ACTIV
AOC9      RECOPER     AUTREC       ACTIV
AOC9      LOGOPER     AUTLOG       ACTIV
AOC9      PPIOPER     AOFARCAT     ACTIV
AOC9      HBOPER     AUTHB        ACTIV
AOC9      RPCOPER     AUTRPC       ACTIV

Command ==>
PF1=Help      PF2=End          PF3=Return      PF6=Roll
                PF9=Refresh      PF12=Retrieve

```

Figure 6. Automation Operators Panel

- The System field shows the name of the system where the automated function is defined
- The Automated Function field shows the name of the automated function used in SA OS/390 automation procedures
- The Primary field shows the NetView automation operator ID assigned to this automated function
- The Status field shows the current status of the primary automation operator
- The Secondary field shows the Backup NetView automation operator ID assigned to this automated function
- The Status field shows the current status of the backup automation operator

The primary and backup NetView automation operator IDs are assigned to the automated function in the command dialogs.

## DISPASF

### Purpose

DISPASF displays the information contained in the automation status file. This includes the:

- Automation status
- Operator ID that last changed the record
- Last threshold exceeded
- Date and time of last monitoring cycle

### Syntax

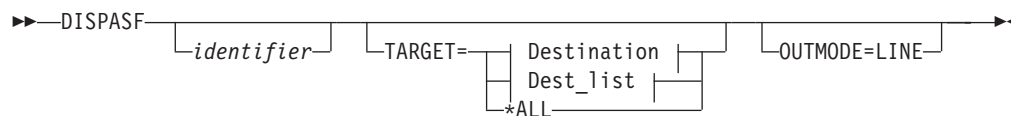
**Destination:****Dest\_list:****Parameters***identifier*

Specifies either a subsystem name, or the name of any resource in the automation status file. You can specify any subsystem identified in the automation control file. If you do not specify a parameter, a panel is displayed on which you can specify an identifier.

**TARGET**

For information on the TARGET parameter, refer to “Additional Parameters for System Operations Commands” on page 10.

**OUTMODE**

For information on the OUTMODE parameter, refer to “Additional Parameters for System Operations Commands” on page 10.

**Restrictions and Limitations**

The DISPASF command can only be used when SA OS/390 is initialized.

**Examples**

If you type `dispasf tso TARGET=*ALL`, you see a panel similar to the following:

# DISPASST

```

A0FK3D0X          SA OS/390 - Command Response      Line 1   of 9
Domain ID  = IPUF9  ----- DISPASF -----        Date = 12/17/97
Operator ID = NETOP1                                     Time = 15:28:19

Command = ASF ID=TSO,REQ=DISP
SYSTEM = AOC9      STATISTICS DISPLAY REQUESTED FOR TSO
-----
STATISTICS DISPLAY REQUESTED FOR TSO
ID= TSO           , TYPE= SUBSYSTEM  , STATUS= UP
LAST UPDATE BY OPERATOR AUTMON
LAST THRESHOLD EXCEEDED -
OPERATOR NOTIFIED: N
LAST STATUS CHANGE DATE= 12/17/97 , TIME= 14:21 , OPID= AUTWRK05
LAST MONITORED DATE= 12/17/97 , TIME= 15:09
NO ERROR DATA AVAILABLE
END OF MULTI-LINE MESSAGE GROUP

Command ==>
PF1=Help      PF2=End      PF3=Return    PF6=Ro11
               PF9=Refresh  PF12=Retrieve
    
```

Figure 7. Display of Automation Status File Information for TSO (DISPASF TSO)

## DISPASST

### Purpose

DISPASST displays information on all resources that have specific assist settings, or that have specific automation flags defined.

### Syntax

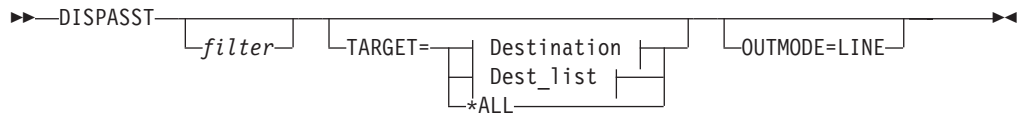

### Destination:



### Dest\_list:



### Parameters

#### filter

Is the filter to be applied for the output. Only resource names that match the filter criteria are displayed. Wildcard is supported. The filter consists of the

major name and, optionally, of a minor name separated by a dot, for example, CICS\*.TRANS\* , or \*.\*CEMT. Specify \* to view major resources. To view minor resources specify xyz.\*.

### TARGET

For information on the TARGET parameter, refer to “Additional Parameters for System Operations Commands” on page 10.

### OUTMODE

For information on the OUTMODE parameter, refer to “Additional Parameters for System Operations Commands” on page 10.

## Restrictions and Limitations

The DISPASST command can only be used when SA OS/390 is initialized.

## Examples

When you type dispasst you see a panel similar to the following:

AOFKAASS		SA OS/390 - Command Dialogs					Line 1 of 23
Domain ID = IPUFG		----- DISPASST -----					Date = 11/25/99
Operator ID = NETOP1							Time = 16:54:08
System	Resource	Assist Setting					Settings
		I	S	R	D	RS	
AOC1	DEFAULTS	-	-	-	-	-	- No setting
AOC1	MVSESA	-	-	-	-	-	None Turned off
AOC1	SUBSYSTEM	-	-	-	-	-	Log Write to Netlog
AOC1	IMS10AA	-	-	-	-	-	Disp Display with SDF
AOC1	DFS554A	-	-	-	-	-	? Error
AOC1	MSC	-	-	-	-	-	
AOC1	0001	-	-	-	-	-	Flags
AOC1	OLDS	-	-	-	-	-	
AOC1	PROG	-	-	-	-	-	I Initial start
AOC1	SAMPLE6	-	-	-	-	-	S Start up
AOC1	TRAN	-	-	-	-	-	R Recovery
AOC1	SAMPLE3	-	-	-	-	-	D Shut down
AOC1	SAMPLE4	-	-	-	-	-	RS Restart
AOC1	IMS10AB	-	-	-	-	-	

Command ==>

PF1=Help	PF2=End	PF3=Return	PF6=Ro11
	PF8=Forward	PF9=Refresh	PF12=Retrieve

Figure 8. DISPASST Command Dialog Panel

- The System field shows the name of the system where the resource is defined.
- The Resource field shows the name of the resource. The entries are sorted alphabetically.

Two types of resources are displayed, major and minor. Major resources are subsystems or ‘generic’ settings, while minor resources are specific situations or resources within a major resource. Automation flags for minor resources are derived from their major resources. Minor resources are shown indented one space to the right under their major resource.

- The Assist Setting fields show current assist settings for each automation flag, for each resource. The flag columns are headed with an abbreviation of the name of the automation flag.

The assist settings are:

- No setting
- None** Assist is turned off
- Log** Write to the netlog

## DISPASST

- Disp** Display with SDF
- ?** There is an error

Refer to *System Automation for OS/390 Defining Automation Policy* for further information about assist mode.

## DISPAUTO

### Purpose

DISPAUTO provides a menu from which you can initiate command dialogs that display information about your automation.

### Syntax

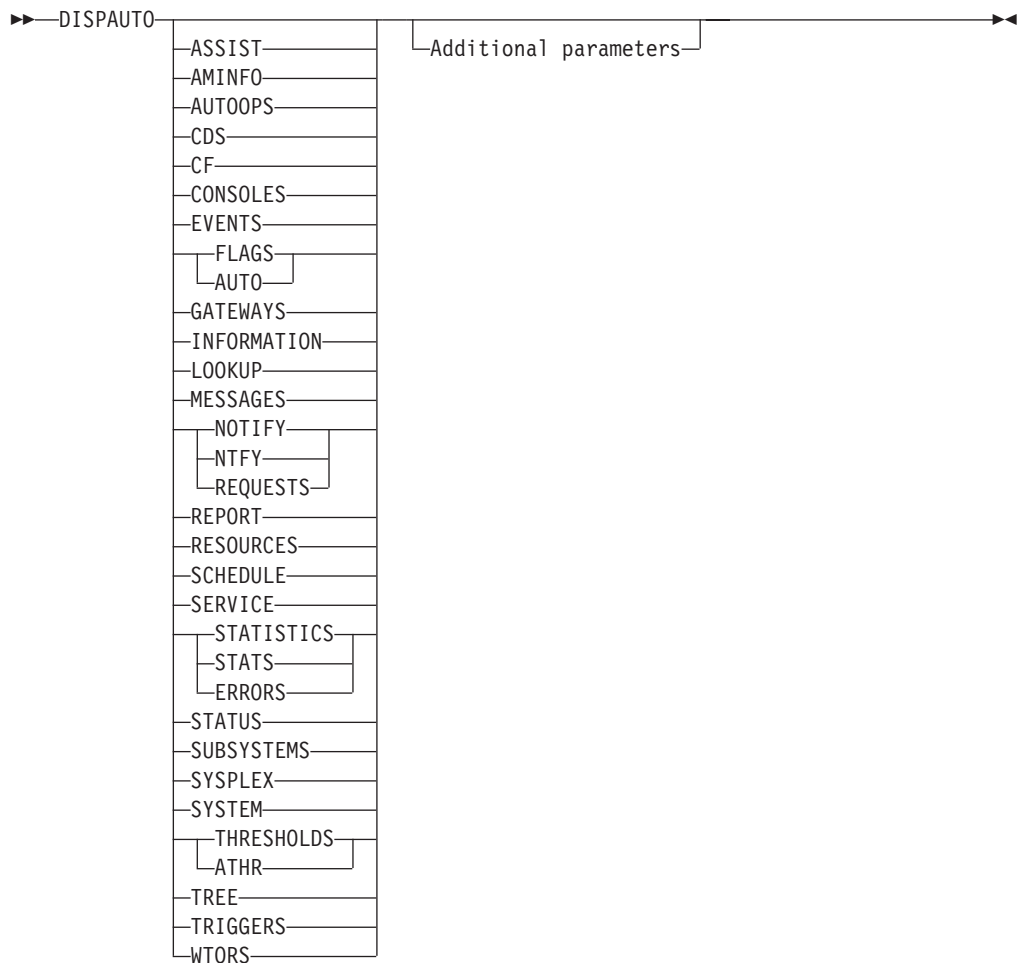

### Parameters

#### ASSIST

Invokes the DISPASST command dialog. See “DISPASST” on page 24 for more information.

#### AMINFO

Invokes the INGAMS command dialog. See “INGAMS” on page 65 for more information.

**AUTOOPS**

Displays the DISPAOPS command dialog. See “DISPAOPS” on page 20 for more information.

**CDS**

Displays the INGPLEX CDS command dialog. See “INGPLEX” on page 132 for more information.

**CF**

Displays the INGCF command dialog. See “INGCF” on page 73 for more information.

**CONSOLES**

Displays the INGPLEX CONSOLE command dialog. See “INGPLEX” on page 132 for more information.

**EVENTS**

Invokes the DISPEVTS command dialog. See “DISPEVTS” on page 33 for more information.

**FLAGS or AUTO**

Invokes the DISPFLGS command dialog. See “DISPFLGS” on page 35 for more information.

**GATEWAYS**

Displays the DISPGW command dialog. See “DISPGW” on page 37 for more information.

**INFORMATION**

Displays the DISPINFO command dialog. See “DISPINFO” on page 42 for more information.

**LOOKUP**

Displays the INGLKUP command dialog. See “INGLKUP” on page 121 for more information.

**MESSAGES**

Displays the DISPMSGS command dialog. See “DISPMSGS” on page 44 for more information.

**NOTIFY or NTFY**

Invokes the DISPNTFY command dialog. See “DISPNTFY” on page 46 for more information.

**REPORT**

Displays the INGRPT command dialog. See “INGRPT” on page 163 for more information.

**REQUESTS**

Displays the INGVOTE command dialog. See “INGVOTE” on page 190 for more information.

**RESOURCES**

Displays the INGLIST command dialog. See “INGLIST” on page 117 for more information.

**SCHEDULE**

Invokes the DISPSCHD command dialog. See “DISPSCHD” on page 47 for more information.

**SERVICE**

Invokes the INGSCHED command dialog. See “INGSCHEd” on page 165 for more information.

## DISPAUTO

### **STATISTICS or ERRORS or STATS**

Invokes the DISPERRS command dialog. See “DISPERRS” on page 29 for more information.

### **STATUS**

Invokes the DISPSTAT command dialog. See “DISPSTAT” on page 51 for more information.

### **SUBSYSTEMS**

Invokes the DISPINFO command dialog. See “DISPINFO” on page 42 for more information.

### **SYSPLEX**

Displays the DISPSYS command dialog. See “DISPSYS” on page 56 for more information.

### **SYSTEM**

Displays the INGPLEX SYS command dialog. See “INGPLEX” on page 132 for more information.

### **THRESHOLDS or ATHR**

Invokes the INGTHRES command dialog. See “INGTHRES” on page 181 for more information.

### **TREE**

Invokes the DISPTREE command dialog. See “DISPTREE” on page 58 for more information.

### **TRIGGERS**

Invokes the INGTRIG command dialog. See “INGTRIG” on page 188 for more information.

### **WTORS**

Displays the DISPWTOR command dialog. See “DISPWTOR” on page 61 for more information.

**Note:** All keywords can be abbreviated to the minimum unique abbreviation. Additional parameters are passed ‘as is’ to the appropriate command routine.

### **Restrictions and Limitations**

The DISPAUTO command can only be used when SA OS/390 is initialized.

### **Usage**

DISPAUTO can be used if you wish to find out information about the system or about automation policy, and cannot remember the appropriate fast path command.

### **Examples**

If you type dispauto on an operator station task (OST) the following panel is displayed:

```

AOFKAADA          SA OS/390 - Command Dialogs      Line 1 of 26
Domain ID = IPSFO ----- DISPAUTO -----      Date = 06/27/02
Operator ID = NETOP1                               Time = 16:09:44

  1  FLAGS          Display current automation flag settings
  2  SCHEDULE       Display all scheduled NOAUTO periods
  3  NOTIFY         Display status of all notify operators
  4  THRESHOLDS    Display all current threshold settings
  5  ERRORS        Display all resources with errors
  6  STATUS        Display the current status of all subsystems
  7  REQUESTS      Display all requests
  8  SUBSYSTEMS    Display information about subsystem
  9  MESSAGES      Display current message assignments
 10  AUTOOPS       Display SA OS/390 controlled autotasks
 11  ASSIST         Display current assist mode settings
 12  WTORS        Display outstanding replies
 13  GATEWAYS      Display gateway status and statistics
 14  SYSTEM        Display system parameters and status
 15  CF           Display coupling facility statuses
 16  CDS          Display couple data set statuses

Command ==>
PF1=Help      PF2=End      PF3=Return      PF6=Ro11
               PF8=Forward  PF12=Retrieve

```

Figure 9. DISPAUTO Command Dialog Panel

After the command selection number, you can specify appropriate parameters for the selected commands, for example, 10 TARGET=xxx, where xxx is the domain ID, or the system name of a system in the sysplex.

## DISPERRS

### Purpose

The DISPERRS command displays information about resources for which errors have been recorded in the status file.

### Syntax

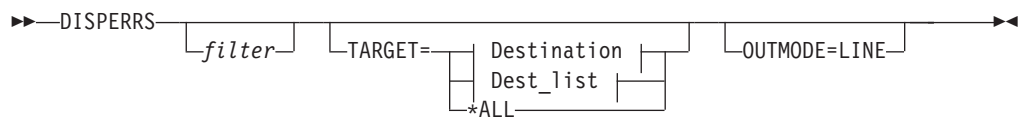

### Destination:



### Dest\_list:



### Parameters

#### filter

Is the filter to be applied for the output. Only resource names that match the

## DISPERRS

filter criteria are displayed. Wildcard is supported. The filter consists of the major name and, optionally, of a minor name separated by a dot, for example, CICS\*.TRANS\* , or \*.\*CEMT.

### TARGET

For information on the TARGET parameter, refer to “Additional Parameters for System Operations Commands” on page 10.

### OUTMODE

For information on the OUTMODE parameter, refer to “Additional Parameters for System Operations Commands” on page 10.

## Restrictions and Limitations

The DISPERRS command can only be used when SA OS/390 is initialized.

## Examples

When you type disperrs you see a panel similar to the following:

```
AOFKAA05          SA OS/390 - Command Dialogs          Line 1   of 25
Domain ID   = IPSFP   ----- DISPERRS -----          Date = 11/10/97
Operator ID = NETOP1                                     Time = 15:20:31
```

System	Resource	Type	Thrs	No	Date	Time
KEY6	AOFIPLDT	CONTROL		8	11/06/97	06:00
KEY6				7	10/27/97	08:18
KEY6				6	10/24/97	06:37
KEY6				5	10/15/97	21:31
KEY6				4	10/10/97	11:17
KEY6				3	10/07/97	09:20
KEY6				2	09/26/97	14:19
KEY6				1	09/02/97	15:00
KEY6	LLA	SUBSYSTEM		1	10/15/97	12:59
KEY6	LOGREC	MVSESA		1	10/01/97	12:50
KEY6	MVSDUMP	MVSESA	FREQ	4	10/15/97	14:59
KEY6				3	10/15/97	14:59
KEY6				2	10/15/97	14:59
KEY6				1	10/15/97	14:59
KEY6	SMFDUMP	MVSESA		1	10/15/97	18:34
KEY6	SYSLOG	MVSESA	CRIT	10	11/07/97	10:05
KEY6				9	11/05/97	18:03
KEY6				8	11/05/97	05:59
KEY6				7	11/03/97	07:07
KEY6				6	10/31/97	15:45
KEY6				5	10/25/97	13:20
KEY6				4	10/24/97	08:16

```
Command ==>
PF1=Help      PF2=End      PF3=Return    PF6=Roll
               PF8=Forward  PF9=Refresh   PF12=Retrieve
```

Figure 10. DISPERRS Command Dialog Panel

- The System field shows the name of the system where the resource is defined.
- The Resource field shows the name of the resource.
- The Type field shows the type of resource.
- The Thrs field shows the type of threshold that has been violated. This is either CRIT (critical), FREQ (frequent), or INFR (infrequent).
- The No field shows the sequence number assigned to the error.
- The Date and Time fields show the date and time that the error occurred.

## DISPEVT

### Purpose

The DISPEVT command displays relationships between an event and the related resources. DISPEVT shows all the resources that use the event.

### Syntax

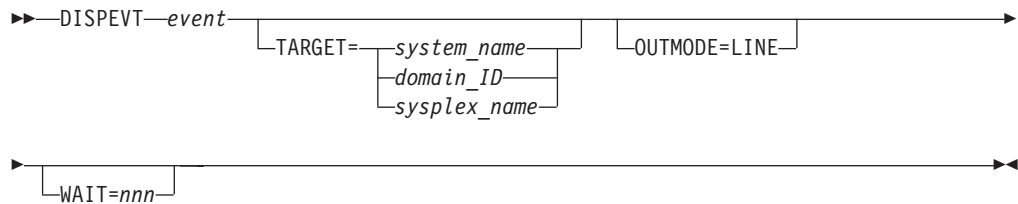

### Parameters

#### *event*

Specifies the name of the event.

#### TARGET

For information on the TARGET parameter, refer to “Additional Parameters for System Operations Commands” on page 10. Note that if you specify a sysplex name as a target, then this is translated to the next system that is available in the sysplex and the DISPEVT command will be processed there.

#### OUTMODE

For information on the OUTMODE parameter, refer to “Additional Parameters for System Operations Commands” on page 10.

#### WAIT

Specifies the number of seconds to wait before reporting that a timeout occurred if the automation manager does not provide the requested data. The maximum time interval is 999 seconds.

If omitted, the time interval is 30 seconds.

### Restrictions and Limitations

The DISPEVT command can only be used when SA OS/390 is initialized.

### Usage

The DISPEVT command operates sysplex-wide. For an overview refer to “Overview of Commands that Operate Sysplex-Wide” on page 9.

Automation manager commands are not supported on downlevel systems. Note that whenever an automation manager command is issued to a target system running an SA OS/390 Version lower than 2.1, the NetView error message DSI002I will not contain the name of the command that was issued but the name of the according slave command.

If you specify OUTMODE=LINE, then specifying *event* becomes mandatory.

The DISPEVT command operates sysplex-wide. For an overview refer to “Overview of Commands that Operate Sysplex-Wide” on page 9.

## Examples

When you type `dispevt b000s100`, the following panel is displayed:

```

AOFLE000          SA OS/390 - Command Dialogs          Line 1   of 4
Domain ID   = IPUF9  ----- DISPEVT -----          Date = 11/26/99
Operator ID = NATOP1          Sysplex = KEY1PLEX          Time = 15:29:27

Event          ==> B000S100
System         ==> KEY3          System name, domain id or sysplex name
Description    . . : Start cond 1 Trigger6 batch job end
Unset condition. : UP

Resource      Type  System  Trigger  Status
-----
TRGG006AA10  APL  KEY1   TRIGGER6  SET
TRGG006AA10  APL  KEY2   TRIGGER6  UNSET
TRGG006AA10  APL  KEY3   TRIGGER6
TRGG006AA10  APL  KEY4   TRIGGER6  SET

Command ==>
PF1=Help      PF2=End          PF3=Return      PF6=Ro11
                PF9=Refresh          PF12=Retrieve

```

Figure 11. DISPEVT Command Dialogs Panel - Result

- The Event field shows the name of the event. You can overwrite the event to initiate a new display.
- The System field shows the name of the system where the command is executed. You can overwrite the system name to initiate a new display.
- The Description field shows the description of the event.
- The Unset condition field shows the status that an application must have to reset an event.
- The Resource field shows the name of the resource where the event is defined.
- The Type field shows the type of the resource.
- The System field shows the name of the system where the resource is defined.
- The Trigger field shows the trigger that the resource is linked to.
- The Status field shows the status of the event for that particular resource. It can contain the following values:

**SET**            The event is set. It is shown in white.

**UNSET**        The event is unset. It is shown in red.

If the status of the event is neither SET nor UNSET, then the event is in an unknown state. This is treated as UNSET.

## DISPEVTS

### Purpose

DISPEVTS displays all events defined in a sysplex. From the full-screen panel you can set or reset an event or display the related resources of an event.

### Syntax

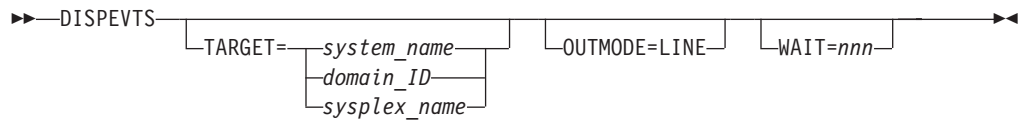

### Parameters

#### TARGET

For information on the TARGET parameter, refer to “Additional Parameters for System Operations Commands” on page 10. Note that if you specify a sysplex name as a target, then this is translated to the next system that is available in the sysplex and the DISPEVTS command will be processed there.

#### OUTMODE

For information on the OUTMODE parameter, refer to “Additional Parameters for System Operations Commands” on page 10.

#### WAIT

Specifies the number of seconds to wait before reporting that a timeout occurred if the automation manager does not provide the requested data. The maximum time interval is 999 seconds.

If omitted, the time interval is 30 seconds.

### Restrictions and Limitations

The DISPEVTS command can only be used when SA OS/390 is initialized.

### Examples

When you type `dispevts`, a panel which shows all events defined in the sysplex, is displayed:

## DISPEVTS

```

AOFLE100          SA OS/390 - Command Dialogs      Line 1   of 38
Domain ID   = IPUF9   ----- DISPEVTS -----      Date = 11/26/99
Operator ID = NETOP1          System = AOC9          Time = 15:00:20

Cmd:  D show related resources      S set/reset event

Cmd Event      Unset  Description
-----
BATCHSTP      NONE   Batch jobs B000P100,P200,P300
BATCHSTR      NONE   Batch jobs B000S100,S200,S300
B000P100      DOWN   Stop cond 1 Trigger6 (batch job end)
B000P200      DOWN   = P1
B000P300      DOWN   Stop cond 2 Trigger6 (batch job 1 min)
B000S100      UP     Start cond 1 Trigger6 batch job end
B000S200      UP     = P1
B000S300      UP     Start cond 2 Trigger 6 batch end (1 min)
DRWEVT1       UP     unset UP
DRWEVT13      NONE   unset none
DRWEVT14      NONE   unset none
DRWEVT15      NONE   unset none

Command ==>
PF1=Help      PF2=End      PF3=Return   PF6=Roll
PF8=Forward   PF9=Refresh  PF12=Retrieve
  
```

Figure 12. DISPEVTS Command Dialogs Panel

- The CMD field lets you specify the command codes shown on the panel. Type the appropriate letter next to the resource name and press Enter. The following command codes are available:
  - D** Shows the related resources.
  - S** Sets or resets the event.
- The Event field shows the name of the event.
- The Unset field shows the status that an application must have to reset an event. The following values can occur:
  - START** Unsets the event when the resource is being started.
  - UP** Unsets the event when the resource becomes available.
  - DOWN** Unsets the event when the resource becomes unavailable.
- If you do not specify anything the event will not be unset.
- The Description field shows the description of the event.

Type S next to an event and press Enter. The following panel is displayed:

```

A0FLE110          SA OS/390 - Command Dialogs
Domain ID   = IPSNO      ----- INGEVENT -----   Date = 03/02/00
Operator ID = NETOP1    Sysplex = KEY1PLEX          Time = 12:35:26

Event . . . . . : EVTSTOP
Description . . . : Shutdown event
Unset condition . : DOWN

Specify/revise the following parameters and then press enter:

Function ==>          SET or UNSET
Resource ==>          Resource name

System ==>           System name, domain ID or sysplex name

Command ==>
F1=Help      F2=End      F3=Return          F6=Roll
              F12=Retrieve

```

Figure 13. DISPEVTS Command Dialogs Panel - Action

- The Event field shows the name of the event.
- The Description field shows the description of the event.
- The Unset condition field shows the status that an application must have to reset an event.
- The Function field shows the action to be performed. It can be overwritten.
- The Resource field shows the name of the application that is the only affected application when the command is executed. It can be overwritten.
- The System field shows the name of the target system where the processing takes place. It can be overwritten. You only need to specify the name of the target system if you want to address a remote sysplex.

## DISPFLGS

### Purpose

The DISPFLGS command shows all resources for which explicit agent automation flags are defined, what those flags are, and what the effective automation flags resulting from them are.

### Syntax

```

▶▶—DISPFLGS— [filter] — [TARGET= [Destination | Dest_list | *ALL] ] — [OUTMODE=LINE] —▶▶

```

### Destination:

```

|— [system_name | domain_ID | sysplex_name] —|

```

# DISPFLGS

**Dest\_list:**



## Parameters

### filter

Is the filter to be applied for the output. Only resource names that match the filter criteria are displayed. Wildcard is supported. The filter consists of the major name and, optionally, of a minor name separated by a dot, for example, CICS\*.TRANS\* , or \*.\*CEMT. Specify \* to view major resources. To view minor resources specify xyz.\*.

### TARGET

For information on the TARGET parameter, refer to “Additional Parameters for System Operations Commands” on page 10.

### OUTMODE

For information on the OUTMODE parameter, refer to “Additional Parameters for System Operations Commands” on page 10.

## Restrictions and Limitations

The DISPFLGS command can only be used when SA OS/390 is initialized.

## Usage

Subsystems which are not shown have no explicit automation flags set and have effective flags defined in the SUBSYSTEM entry.

## Examples

When you type dispflgs within SA OS/390 you see a panel similar to the following:

```

AOFKAAU                SA OS/390 - Command Dialogs          Line 1   of 123
Domain ID = IPSFM      ----- DISPFLGS -----           Date = 04/23/02
Operator ID = NETOP1                                       Time = 15:33:38

Cmd:  A Add flags      C Change flags      R Reset flags      S Scheduled Overrides
                                     Actual          Effective
Cmd  System  Resource  A I S R D RS  A I S R D RS
-----
KEY1  APPC
KEY1  ASCH
KEY1  CICSK1G
KEY1  AUTO
KEY1  SOS
KEY1  TRAN
KEY1  VIOL
KEY1  VTAMACB
KEY1  CICSK1H
KEY1  AUTO
KEY1  SOS
KEY1  TRAN

Command ==>
PF1=Help      PF2=End      PF3=Return    PF6=Ro11
PF8=Forward   PF9=Refresh  PF12=Retrieve
    
```

Figure 14. DISPFLGS Command Dialog Panel of SA OS/390

The following command codes are available:

## DISPFLGS

- A Lets you define automation flags for a resource using the same flag settings as the selected resource. On the next panel displayed you can specify the resource name and optionally overtype the flag settings.
  - C Lets you modify the automation flags of the selected resource. The next panel shows the current flag settings. You can overtype the flag values.
  - R Resets the automation flags to the values specified in the automation control file (ACF).
  - S Shows the scheduled override settings of the automation flags for the selected resource.
- The Resource field shows the name of the resource. Names shown indented one character to the right represent minor resources, for example, MVSESA.DUMP as shown below. If the minor resources MVSESA.DUMP.ONE, MVSESA.DUMP.TWO, and MVSESA.DUMP.TWO.THREE existed, the Resource column would look like the example below:

```
MVSESA
  DUMP
    ONE
    TWO
    THREE
```

Major resources correspond to subsystems and minor resources correspond to specific situations or resources within a major resource. By default, automation flags for minor resources are derived from their major resources.

The entries are sorted alphabetically.

- The Actual flag settings are the flags that have been set for the resource.
- The Effective flag settings are the flags that are in effect for the resource.

The columns are headed with an abbreviation of the name of the automation flag.

The value of each flag is:

- There is no explicit setting
- N The flag is turned off
- E A user exit is invoked whenever SA OS/390 checks the flag
- Y The flag is turned on
- ? There is an error

Refer to *System Automation for OS/390 Customizing and Programming* for further information on automation flags and minor resources.

## DISPGW

### Purpose

DISPGW displays gateway definitions, statuses, and statistics.

### Syntax

```
▶▶ DISPGW [TARGET=system_name] [OUTMODE=LINE]
           |
           | domain_ID
           |
           | sysplex_name
```

## Parameters

### TARGET

For information on the TARGET parameter, refer to “Additional Parameters for System Operations Commands” on page 10.

### OUTMODE

For information on the OUTMODE parameter, refer to “Additional Parameters for System Operations Commands” on page 10.

## Restrictions and Limitations

The DISPGW command can only be used when SA OS/390 is initialized.

## Usage

There are three related panels which display gateway information. Use PF11 and PF10 to scroll through them.

## Examples

When you type dispgw you see a panel similar to the following:

```

A0FK2GL                SA OS/390 - Command Dialogs                Line 1  of 11
Domain ID = IPUF9      ----- DISPGW -----                Date = 12/17/97
Operator ID = NETOP1                                     Time = 15:32:36
System = AOC9                                           Focal Point = IPSFM
Domain  Sdfroot      Status   Description
-----
IPSFM   KEY3         ACTIVE   CONNECTION TO IPSFM (KEY3)
IPSFN                                     NOT STARTD CONNECTION TO IPSFN (KEY4)
IPSFO                                     NOT STARTD CONNECTION TO IPSFO (KEY5)
IPSFP                                     NOT STARTD CONNECTION TO IPSFP (KEY6)
IPUFA                                     NOT STARTD CONNECTION TO IPUFA (AOCA)
IPUFB                                     NOT STARTD CONNECTION TO IPUFB (AOCB)
IPUFC                                     NOT STARTD CONNECTION TO IPUFC (AOCC)
IPUFD                                     NOT STARTD CONNECTION TO IPUFD (AOCD)
IPUFM   AOC7         ACTIVE   CONNECTION TO IPUFM (AOC7)
IPUF8                                     NOT STARTD CONNECTION TO IPUF8 (AOC8)
IPVFH                                     NOT STARTD CONNECTION TO IPVFH (TSCF2)

Command ==>
PF1=Help  PF2=End  PF3=Return  PF6=Ro11
PF9=Refresh  PF11=Right  PF12=Retrieve

```

Figure 15. DISPGW Command Dialog Panel 1

- The Domain field shows the domain ID of the system to which a gateway has been defined, known as the *gateway domain*.
- The Sdfroot field shows the system name of the gateway domain.
- The Status field shows the current status of the gateway.

The following are statuses that may occur for gateways and NNT sessions:

### ACTIVE

The connection was established.

### AUTHORITY

The user is not authorized. Message: DSI755I.

### BAD DOMAIN

The specified domain is unknown. Message: DSI031I.

### BAD EVENT

**G** Wait ended by operator GO

**E** Wait statement incorrect

### BAD PWMASK

The security software rejected a new password. Message: DSI754I.

**CMD ERROR**

A cross-domain command was rejected. Messages: DSI002I CNM421I.

**DS NTALLOC**

The NetView password data set is not allocated. Message: AOF088I.

**DUP LOGON**

The specified operator ID is already logged on. Message: DSI068I.

**EXP PASSWD**

The specified password has expired. Messages: DSI402I DSI756I.

**GETPW UPD**

An error occurred updating the RACF<sup>®</sup> password.

**GETPW ERR**

An error occurred using the GETPW command.

**ID REVOKED**

The user ID has been revoked. Message: DSI679I.

**INACTIVE**

The connection cannot be established. One of the following messages was issued: DSI008I, DSI015A, DSI027I.

**INV LOGON**

The logon attempt is invalid. Message: DSI029I.

**INV OPID**

The specified operator ID is invalid. Messages: DSI021A, DSI077A, DSI400A.

**INV PASSWD**

The specified password is invalid. Messages: DSI022A, DSI401A.

**NOT STARTD**

The domain has not been started by Gateway initialization.

**PROF ERR**

The specified user profile has an error or is invalid. Messages: DSI023A, DSI057A, DSI059A, DSI060A, DSI061A, DSI062A.

**PW NTFND**

The password was not found by the GETPW command. Message AOF089I.

**SAF FAIL**

A SAF related failure occurred. Messages: DSI403I, DSI405I.

**SESSFAL**

The attempt to start a session with the domain ended with a VTAM<sup>®</sup> request failure. Refer to DSI046I\$ in the netlog for details.

**STARTING**

The session is currently being started by gateway initialization.

**TERM SESS**

The session was terminated. Messages: DSI055I, DSI145I.

**TIMEOUT**

A message has not been received in the time specified (XDOM).

- The Description field shows a description of the gateway domain, obtained from the automation control file.

If you press PF11 on this panel, a panel similar to the following is displayed:

## DISPGW

```

A0FK2GLR          SA OS/390 - Command Dialogs      Line 1   of 11
Domain ID = IPUF9  ----- DISPGW -----         Date = 11/26/99
Operator ID = NETOP1                               Time = 16:01:19
System = AOC9                                       Focal Point = IPUFM
Domain   via     Direct Inb/Outb Stat  Adjacent  Alt Adj  Product
-----
IPSFM   IPSFM   ACTIVE   ACTIVE
IPSFN   IPSFN   INACTIVE ACTIVE
IPSF0   IPSF0   INACTIVE ACTIVE
IPSFp   IPSFP   INACTIVE ACTIVE
IPUFA   IPUFA   INACTIVE ACTIVE
IPUFB   IPUFB   INACTIVE ACTIVE
IPUFC   IPUFC   INACTIVE ACTIVE
IPUFD   IPUFD   INACTIVE ACTIVE
IPUFM   IPUFM   ACTIVE   ACTIVE
IPUF8   IPUF8   INACTIVE SESSFAIL
IPVFH   IPVFH   INACTIVE INV OPID
-----
Product: SA OS/390 2.1
SA OS/390 2.1

Command ==>
PF1=Help  PF2=End  PF3=Return  PF6=Ro11
PF9=Refresh PF10=Left PF11=Right  PF12=Retrieve

```

Figure 16. DISPGW Command Dialog Panel 2

- The Domain field shows the domain ID of the system to which a gateway has been defined, known as the *gateway domain*.
  - The Via field shows the domain through which this system is communicating with the gateway domain.
  - The Direct Inb/Outb Stat field shows the inbound and outbound NetView sessions from this domain to the gateway domain. If this domain communicates with the gateway through another domain, the status is NO DIRECT.
  - The Adjacent field shows the adjacent domain through which this gateway is connected.
  - The Alt Adj field shows the alternate adjacent domain through which this gateway is connected.
  - The Product field shows the automation product on the gateway domain.
- If you press PF11 on this panel, a panel similar to the following is displayed:

A0FK2GLC		SA OS/390 - Command Dialogs				Line 1 of 11	
Domain ID = IPUF9		----- DISPGW -----				Date = 12/17/97	
Operator ID = NETOP1						Time = 15:36:56	
System = AOC9						Focal Point = IPSFM	
Domain	Req to/from	Last out/in		INT to/from	Invalid	Loop back	
IPSFM	148 71	DOMSTA	DOMSTA	0 0	0	0 0	
IPSFN	20 0	DOMCON		0 0	0	0 0	
IPSF0	19 0	DOMCON		0 0	0	0 0	
IPSFp	20 0	DOMCON		0 0	0	0 0	
IPUFA	28 0	DOMCON		0 0	0	0 0	
IPUFB	23 0	DOMCON		0 0	0	0 0	
IPUFC	27 0	DOMCON		0 0	0	0 0	
IPUFD	25 0	DOMCON		0 0	0	0 0	
IPUFM	59 97	DOMSTA	DOMSTA	0 0	0	0 0	
IPUF8	22 0	DOMCON		0 0	0	0 0	
IPVFH	0 0			0 0	0	0 0	

Command ==>  
 PF1=Help PF2=End PF3=Return PF6=Ro11  
 PF9=Refresh PF10=Left PF12=Retrieve

Figure 17. DISPGW Command Dialog Panel 3

- The Domain field is the same as on the previous panel.
- The Req to/from field shows the number of gateway requests to the gateway domain from this domain, and from the gateway domain to this domain.
- The Last out/in field shows the first 8 bytes of the last gateway request from this domain to the gateway domain, and the last gateway request from the gateway domain to this domain.
- The Int to/from field shows the number of gateway requests between the gateway domain and the other domains that were routed through this domain.
- The Invalid field shows the number of requests to this domain from the gateway domain that were invalid.
- The Loop back field shows the number of requests from this domain to the gateway domain that looped back to this domain.

## DISPINFO

### DISPINFO

#### Purpose

DISPINFO displays detailed information about a specified subsystem.

If the subsystem is a CICS or IMS subsystem that is being controlled by CICS Automation or IMS Automation, a PF10 option is available to give access to CICS or IMS related information. Refer to the examples section for more details.

#### Syntax

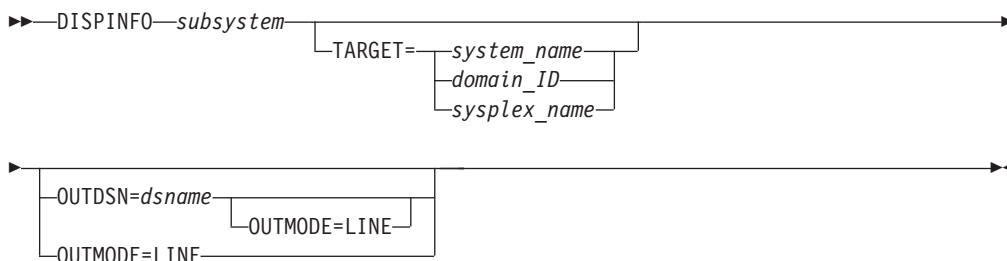

#### Parameters

##### *subsystem*

The name of the subsystem you want information on. If you do not specify a subsystem, a menu is displayed on which you can specify the subsystem.

##### TARGET

For information on the TARGET parameter, refer to “Additional Parameters for System Operations Commands” on page 10.

##### OUTMODE

For information on the OUTMODE parameter, refer to “Additional Parameters for System Operations Commands” on page 10.

##### OUTDSN

For information on the OUTDSN parameter, refer to “Additional Parameters for System Operations Commands” on page 10.

#### Restrictions and Limitations

The DISPINFO command can only be used when SA OS/390 is initialized.

#### Examples

```

AOFKINFO          SA OS/390 - Command Dialogs          Line 1 of 228
Domain ID = IPSFM  ----- DISPINFO -----          Date = 05/06/02
Operator ID = NETOP1                               Time = 08:48:38

Subsystem ==> CICSK1H      System ==> KEY1      System name, domain ID
                                                or sysplex name
Subsystem   : CICSK1H      on System : KEY1

Description  : CICS TS V2.1 KEY1 with TCP/IP

Class       : CICS_TS13

Job Name    : CICSK1H

Job Type    : MVS

Category    : CICS

Current status : STOPPED
Last Monitored : 08:34:55 on 05/06/02
Last Changed  : 09:30:20 on 05/02/02
Last Message  :
                AOF571I 09:30:20 : CICSK1H SUBSYSTEM STATUS FOR JOB CICSK1H IS
                STOPPED - SHUTDOWN OUTSIDE OF AUTOMATION, RESTARTOPT ==
                ALWAYS

Monitor      : AOFAJMON (default)
Monitor Status : INACTIVE

Monitor Interval : None specified

ARM Element Name : SYSCICS_IPSAMCIH
ARM Status      : UNREGISTERED

Association    : Primary

WLM Resource Name : STC

Managing Feature : CICS

Command Prefix : None

Flags - Automation : Yes
      Init Start  : Yes
      Start       : Yes
      Recovery    : Yes
      Shut Down   : Yes
      Restart     : Yes

Restart after IPL      : MAYBE
Restart after Recycle : MAYBE
Restart when Stopped  : ABENDONLY

Thresholds - CICSK1H  SUBSYSTEM  DEFAULTS
Critical   : Undefined 1 in 00:05  Undefined
Frequent   : Undefined 1 in 00:30  Undefined
Infrequent : Undefined 1 in 01:00  Undefined

Active Startup : None
Active Shutdown : None

CICS Information :
Version        : 6.1 (Transaction Server V2.1)
Indoubt UOW    : NO
Last Start Type : WARM

Start Up Mechanism :
Scheduling Subsystem : JES2
External startup   : NEVER

Command ==>
PF1=Help  PF2=End    PF3=Return  PF4=INGINFO          PF6=Roll
PF7=Back  PF8=Forward PF9=Refresh  PF10=CICS Info      PF12=Retrieve

```

Figure 18. DISPINFO Command Dialog Panel

## DISPINFO

If applicable the DISPINFO command invokes the INGCICS or INGIMS commands.

```
EVEKYCMD          SA OS/390 - Command Dialogs  Line 1  of 3
Domain ID = IPSFM  ----- INGCICS -----      Date = 05/06/02
Operator ID = NETOP1                               Time = 08:49:12

Resource          => CICS1H/APL/KEY1             Format: name/type/system
System            =>                               System name, domain ID or sysplex name
Request          => INFO                          CMD, BROADCAST or INFO
CICS Transaction =>
CICS Route       =>
CICS Message     =>
                 =>

TASK STATUS
IEE341I CICS1H          NOT ACTIVE

Command ==>
PF1=Help    PF2=End    PF3=Return  PF4=DISPINFO    PF6=Roll
PF9=Refresh                                PF12=Retrieve
```

Figure 19. INGCICS Command Dialog Panel

For the subsystem and the system fields, you can override the values and refresh the display. You can also scroll forward and backward.

For further details about the fields on the panel, refer to the online help and to *System Automation for OS/390 Defining Automation Policy*.

When obtaining automation flag settings, no user exits are invoked.

To display the default settings use the subsystem name DEFAULTS or SUBSYSTEM.

PF4 lets you toggle to the automation manager command INGINFO.

If applicable, DISPINFO invokes the INGCICS or the INGIMS command.

## DISPMSGGS

### Purpose

The DISPMSGGS command displays which automation operators receive the automated messages.

### Syntax

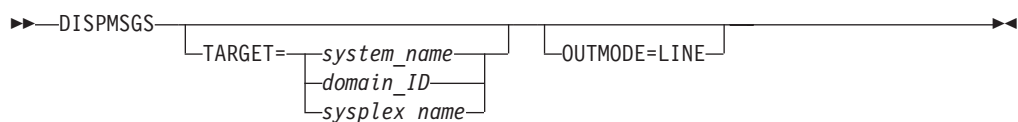

## Parameters

### TARGET

For information on the TARGET parameter, refer to “Additional Parameters for System Operations Commands” on page 10.

### OUTMODE

For information on the OUTMODE parameter, refer to “Additional Parameters for System Operations Commands” on page 10.

## Restrictions and Limitations

The DISPMSGSG command can only be used when SA OS/390 is initialized.

## Examples

Type dispmsgsg on a command line to display the Authorized Message Receivers panel:

```

AOFK2SM                SA OS/390 - Command Dialogs                Line 1 of 17
Domain ID = IPSNO      ----- DISPMSGSG -----                Date = 06/27/00
Operator ID = NETOP1   System _ KEY3                            Time = 15:05:53

Message  Primary Receivers                Secondary Receivers
-----  -----
'*AOF01' AUTWRK01 AUTGSS  AUTSYS
          AUTBASE
'*AOF02' AUTWRK02 AUTGSS  AUTSYS
          AUTBASE
'*AOF03' AUTWRK03 AUTGSS  AUTSYS
          AUTBASE
'*AOF04' AUTWRK04 AUTGSS  AUTSYS
          AUTBASE
'*AOF05' AUTWRK05 AUTGSS  AUTSYS
          AUTBASE
'AOF*'   AUTMSG  AUTSYS  AUTBASE
'IEA*'   AUTREC  AUTSYS  AUTBASE
'IEE600I AUTSYS
'IEE889I AUTSYS  AUTBASE
'IEE*'   AUTREC  AUTSYS  AUTBASE
'IOS*'   AUTREC  AUTSYS  AUTBASE
'*'      AUTLOG  AUTSYS  AUTBASE

Command ==>
PF1=Help   PF2=End           PF3=Return   PF6=Roll
PF9=Refresh PF12=Retrieve

```

Figure 20. Authorized Message Receivers Panel

The information contained on the panel is:

- The Message field shows the message or message prefix.
- The Primary Receivers field shows the automation operators, identified by their NetView IDs. The Primary Receivers column lists automation operators that can receive the messages listed beside their names. These messages go to the first automation operator listed in the Primary Receivers column that is active.
- The Secondary Receivers field shows the Alternate automation operators, identified by their NetView IDs. Secondary Receivers receive copies of the messages listed beside their names.

## DISPNTFY

### DISPNTFY

#### Purpose

The DISPNTFY command displays a list of all defined notification operators, whether they are logged on, whether they are receiving messages, and a description of the operator.

#### Syntax

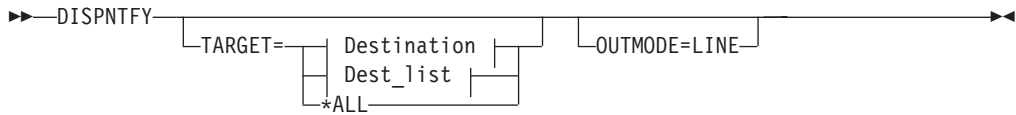

#### Destination:



#### Dest\_list:



#### Parameters

##### TARGET

For information on the TARGET parameter, refer to “Additional Parameters for System Operations Commands” on page 10.

##### OUTMODE

For information on the OUTMODE parameter, refer to “Additional Parameters for System Operations Commands” on page 10.

#### Restrictions and Limitations

The DISPNTFY command can only be used when SA OS/390 is initialized.

#### Usage

Use the INGNTFY QUERY command dialog to find out which classes of message each operator is receiving.

#### Examples

When you type dispntfy you see a panel similar to the following:

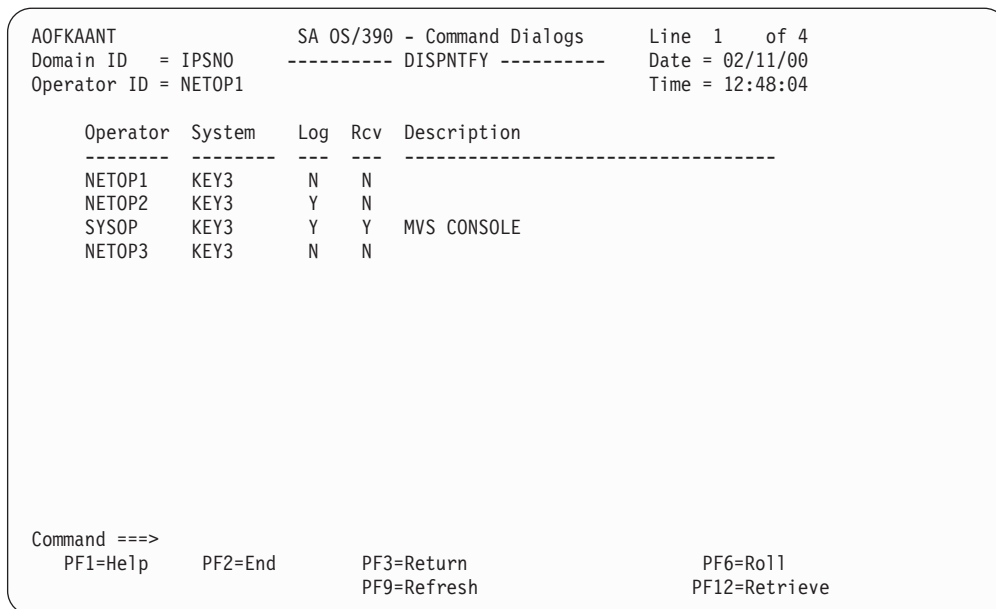

Figure 21. DISPNTFY Command Dialog Panel

- The Operator field shows the operator ID. It is not necessarily defined to NetView.
- The System field shows the name of the system where the operator is defined.
- The Log field shows a Y if the operator was logged on when the command dialog was started, and shows an N if the operator was not logged on.
- The Rcv (Receive) field shows a Y if the operator was receiving messages when the command dialog was started, and shows an N if the operator was not receiving messages.
- The Description field shows a description of the operator, from either the automation control file or the INGNTFY command dialog.

## DISPSCHD

### Purpose

DISPSCHD displays all resources with scheduled override settings of the automation flags. Scheduled overrides are specified using the customization dialog. They are specific times during which automation is turned off for a particular flag and resource.

### Syntax

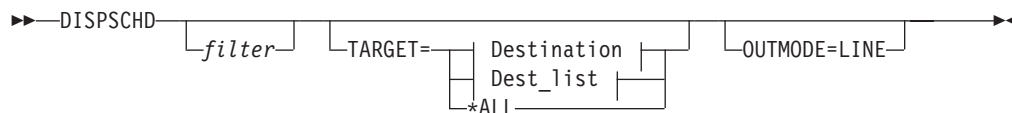

### Destination:



# DISPSCHD

## Dest\_list:



## Parameters

### filter

Is the filter to be applied for the output. Only resource names that match the filter criteria are displayed. Wildcard is supported. The filter consists of the major name and, optionally, of a minor name separated by a dot, for example, CICS\*.TRANS\* , or \*.\*CEMT. Specify \* to view major resources. To view minor resources specify xyz.\*.

### TARGET

For information on the TARGET parameter, refer to “Additional Parameters for System Operations Commands” on page 10.

### OUTMODE

For information on the OUTMODE parameter, refer to “Additional Parameters for System Operations Commands” on page 10.

## Restrictions and Limitations

The DISPSCHD command can only be used when SA OS/390 is initialized.

## Examples

When you type dispschd a panel similar to the following is displayed:

AOFKAASC		SA OS/390 - Command Dialogs			Line 1 of 6	
Domain ID = IPUF9		----- DISPSCHD -----			Date = 12/17/97	
Operator ID = NETOP1					Time = 15:47:07	
System	Resource	Fl	Day	Start	- End	Flags
AOC9	CICST	A	WEEKDAY	07:30:00	- 04:00:00	A Automation
AOC9			THURSDAY	03:00:00	- 05:00:00	I Initial Start
AOC9		I	*	12:00:00	- 13:00:00	S Start up
AOC9		R	WEEKEND	18:00:00	- 19:00:00	R Recovery
AOC9		RS	*	12:00:00	- 13:00:00	D Shut down
AOC9	MVSDUMP	R	*	07:00:00	- 18:00:00	RS Restart
Command ==>						
PF1=Help		PF2=End		PF3=Return		PF6=Roll
				PF9=Refresh		PF12=Retrieve

Figure 22. DISPSCHD Command Dialog Panel

- The System field shows the name of the system where the resource is defined.
- The Resource field shows the name of resources which have NOAUTO specified in the automation control file. The resources are displayed in the order in which they occur in the automation control file.
- The Fl (Flag) field shows an abbreviation of the automation flag name.
- The Day field shows the day or days on which automation is turned off. Valid values are:
  - Monday through Sunday
  - \* (for every day)
  - Weekend

- Weekday
- The Flags field shows the names of the automation flags and their abbreviations.

## DISPSFLT

### Purpose

The DISPSFLT command lets you set up view filters for DISPSTAT.

### Syntax

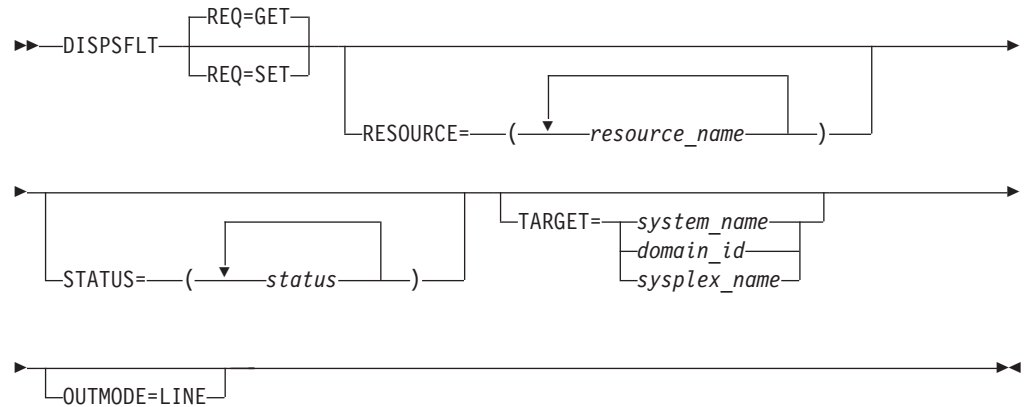

### Parameters

#### REQ

Specifies the type of the request. It can be one of the following:

**SET** Specifies to set new filter settings

**GET** Specifies to return the current filter settings. This is the default.

#### RESOURCE

Specifies the name of the resource(s) to be displayed. The format is *resource name*. It can be a list of names. Wildcards are supported. If you specify only one resource you need not put it in parentheses.

#### STATUS

Specifies the resource statuses that you want to display. If more than one is specified, separate the statuses with a blank. The status or list of statuses must be inside single quotation marks. If '-', or '\ ' is used, all statuses except the ones you specify are displayed.

There are some predefined lists:

#### STATUS=\*

Lists all resource statuses.

#### STATUS=1

Lists all resources that are currently UP or ENDED.

#### STATUS=2

Lists all resources that are in a 'normal' status (DOWN, STARTED, UP, AUTOTERM, AUTODOWN, ACTIVE, ENDED, ENDING, RESTART, EXTSTART, RUNNING).

## DISPSFLT

### STATUS=3

Lists all resources that are in a 'down' status (DOWN, INACTIVE, RESTART, AUTODOWN, CTLDOWN, STOPPED, BROKEN, MOVED, FALLBACK).

### STATUS=4

Lists all resources that are in a start transition status (RESTART, STARTED, STARTED2, ACTIVE, RUNNING, EXTSTART).

### STATUS=5

Lists all resources that are in a stop transition status (AUTOTERM, ENDING, STOPPING, ABENDING, BREAKING)

### TARGET

For information on the TARGET parameter, refer to "Additional Parameters for System Operations Commands" on page 10.

### OUTMODE

For information on the OUTMODE parameter, refer to "Additional Parameters for System Operations Commands" on page 10.

If no parameters are specified, the filter settings are used.

If a subsystem name is specified, but no other parameters, for example, TARGET=, are specified, all subsystems of this name found on any system will be displayed.

### Usage

The DISPSFLT command can also be used when SA OS/390 is **not** initialized.

The DISPSFLT command lets you set filter options at operator logon from within the operator's initial clist.

### Examples

If the operator is responsible for all resources starting with xyz, DISPSFLT will be called with the parameter RESOURCE=xyz. If you type dispsflt a panel similar to the following is displayed:

```

AOFKSTA3          SA OS/390 - Command Dialogs
Domain ID   = IPSNO   ----- DISPSFLT -----   Date = 06/27/00
Operator ID = NETOP1                                Time = 15:08:40

Resources      ( *, *sour*, resource or jobname )
*

Statuses      ( *, status or choice, leading ~ or \ negates)
RESTART STARTED STARTED2 ACTIVE RUNNING EXTSTART

Precoded: 1 All resources that are currently UP or ENDED
          2 All resources that are in a normal status
          3 All resources that are in a down status
          4 All resources that are in a start transition state
          5 All resources that are in a stop transition state

Target Systems ( system name , domain ID , sysplex name or * )
KEY3

Command ==>
PF1=Help   PF2=End   PF3=Return   PF4=Clear   PF5=Reset   PF6=Roll
PF9=Save   PF12=Retrieve

```

Figure 23. DISPSFLT Sample Panel

Filters are used to tailor the DISPSTAT display. To be displayed, a subsystem must pass all the filter criteria. If a filter is not explicitly set, it defaults to '\*', which means that all subsystems pass it. Some filters allow you to specify a wildcard character, in the form of a trailing '\*'.

- The Resources field contains the name of the resources or their jobs.
- The Statuses field shows the subsystem's current status. If '~', or '\ ' is specified, all statuses not specified are used.
- The Target Systems field shows the name of the target system.
- If you press PF4 the filter settings are cleared.

Subsystems are evaluated to see if they meet the current filter criteria:

- When DISPSTAT is invoked with filter parameters
- When the filters are changed through the DISPSTAT Filters panel
- When the Refresh key (PF9) is selected from the DISPSTAT panel.

**Note:** If you make changes on this panel, and then decide that you do not want these changes to take effect, you can select the Reset key (PF5), which reinstates the field values that were present when you entered the panel. If you press PF9 the filter settings are saved until the session is terminated.

## DISPSTAT

### Purpose

DISPSTAT displays current information about one or more subsystems.

### Syntax

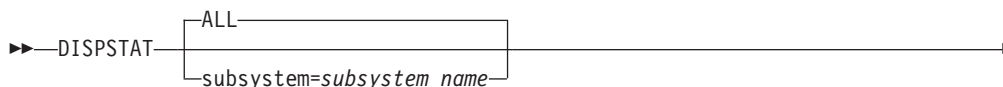

## DISPSTAT

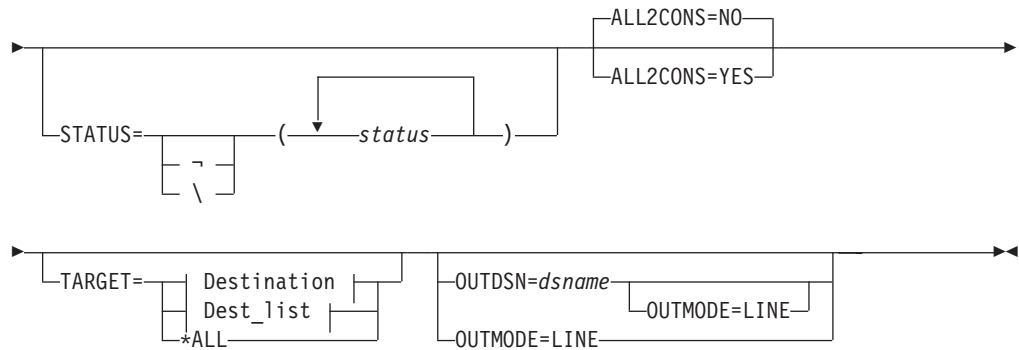

### Destination:



### Dest\_list:



## Parameters

### ALL

Displays the current information for all automated subsystems.

### subsystem

Specifies the particular subsystem whose status or automation flags you want to check. You can specify any automated subsystem.

### STATUS

Specifies the resource statuses that you want to display. If more than one is specified, separate the statuses with a blank. The status or list of statuses must be enclosed in single quotation marks. If '-', or '\ ' is used, all statuses except the ones you specify are displayed.

There are some predefined lists:

#### STATUS=\*

Lists all resource statuses.

#### STATUS=1

Lists all resources that are currently UP or ENDED.

#### STATUS=2

Lists all resources that are in a 'normal' status (DOWN, STARTED, UP, AUTOTERM, AUTODOWN, ACTIVE, ENDED, ENDING, RESTART, EXTSTART, RUNNING).

#### STATUS=3

Lists all resources that are in a 'down' status (DOWN, INACTIVE, RESTART, AUTODOWN, CTLDOWN, STOPPED, BROKEN, MOVED, FALLBACK).

**STATUS=4**

Lists all resources that are in a start transition status (RESTART, STARTED, STARTED2, ACTIVE, RUNNING, EXTSTART).

**STATUS=5**

Lists all resources that are in a stop transition status (AUTOTERM, ENDING, STOPPING, ABENDING, BREAKING)

**ALL2CONS**

Specifies whether or not a complete list of columns is displayed. The parameter only applies to line mode. The following are valid values:

**NO** Displays only 60 characters of display data for each resource. This is the default.

**YES** Displays the complete list of columns.

For example, you can specify:

```
DISPSTAT cics* OUTMODE=LINE ALL2CONS=YES
```

**TARGET**

For information on the TARGET parameter, refer to “Additional Parameters for System Operations Commands” on page 10.

**OUTMODE**

For information on the OUTMODE parameter, refer to “Additional Parameters for System Operations Commands” on page 10.

**OUTDSN**

For information on the OUTDSN parameter, refer to “Additional Parameters for System Operations Commands” on page 10. Note, however, that for the DISPSTAT command the minimum record length of the output data set is 256 bytes.

If no parameters are specified, the filter settings will be used, or, if not set, DISPSTAT will show all resources of the sysplex.

If a subsystem name is specified, but no other parameters, for example, TARGET=, are specified, all subsystems of this name found on any system will be displayed.

**Restrictions and Limitations**

The DISPSTAT command can only be used when SA OS/390 is initialized.

**Examples**

If you type dispstat, you see information about all automated resources:

## DISPSTAT

```

AOFKSTA5          SA OS/390 - Command Dialogs          Line 1 of 442
Domain ID = IPSFO ----- DISPSTAT -----          Date = 04/17/00
Operator ID = NETOP1                                Time = 14:24:01
A ingauto B setstate C ingreq-stop D hresholds E explain F info G tree
H trigger I service J all children K children L all parents M parents
CMD RESOURCE      STATUS      SYSTEM      JOB NAME      A I S R D RS TYPE      Activity
-----
AGFG              BROKEN      KEY3        AGFG          Y Y Y Y Y Y MVS      --none--
AGFG2             BROKEN      KEY3        AGFG2         Y Y Y Y Y Y MVS      --none--
ANELSTP1          UP          KEY3        ANELSTP1     Y Y Y Y Y Y MVS      STOPPING
ANELTEST          UP          KEY3        ANELTEST     Y Y Y Y Y Y MVS      STOPPING
ANEL0AA1          UP          KEY3        ANEL0AA1     Y Y Y Y Y Y MVS      --none--
ANEL00A1          UP          KEY3        ANEL00A1     Y Y Y Y Y Y MVS      STOPPING
ANEL00B1          UP          KEY3        ANEL00B1     Y Y Y Y Y Y MVS      STOPPING
ANEL00B2          UP          KEY3        ANEL00B2     Y Y Y Y Y Y MVS      --none--
ANEL00B3          UP          KEY3        ANEL00B3     Y Y Y Y Y Y MVS      --none--
ANEL00B4          UP          KEY3        ANEL00B4     Y Y Y Y Y Y MVS      --none--
ANEL00B5          UP          KEY3        ANEL00B5     Y Y Y Y Y Y MVS      --none--
ANEL00C1          UP          KEY3        ANEL00C1     Y Y Y Y Y Y MVS      --none--
APPC              UP          KEY3        APPC          Y Y Y Y Y Y MVS      --none--
ASCH              UP          KEY3        ASCH          Y Y Y Y Y Y MVS      --none--
BATB000P100      DOWN       KEY3        B000P100     Y Y Y Y Y Y TRANS  --none--
BATB000P200      DOWN       KEY3        B000P200     Y Y Y Y Y Y TRANS  --none--
BATB000P300      DOWN       KEY3        B000P300     Y Y Y Y Y Y TRANS  --none--
BATB000S100      DOWN       KEY3        B000S100     Y Y Y Y Y Y TRANS  --none--
BATB000S200      DOWN       KEY3        B000S200     Y Y Y Y Y Y TRANS  --none--
BATB000S300      DOWN       KEY3        B000S300     Y Y Y Y Y Y TRANS  --none--
BLSJPRMI         ENDED      KEY3        BLSJPRMI     Y Y Y Y Y Y ONE SHOT --none--

Command ==>
PF1=Help   PF2=End     PF3=Return  PF4=INGLIST  PF5=Filters  PF6=Roll
PF8=Forward PF9=Refresh PF10=Previous PF11=Next   PF12=Retrieve

```

Figure 24. Display of Status of All Automated Resources (DISPSTAT)

- The CMD field allows you to invoke other SA OS/390 command dialogs, or control the amount of information displayed. To use one of the command dialogs, type the appropriate letter next to the resource name, and press Enter. When you return to this panel the data within the command scope is refreshed. The current filters are not re-applied until you select Refresh (PF9).

For example, to invoke the INGTHRES dialog in order to change thresholds for JES2, move the cursor in front of JES2 and type d.

You can specify X to exclude subsystems.

**Note:** The U command code is supported if the AOFEXC04 exit is installed.

- The RESOURCE field shows the name of the resource in its corresponding status color, for example, green when the system is UP.
- The STATUS field shows the current status of the resource.
- The automation flags are:
  - A** If this flag is set to N (No), no automation is on, regardless of how the other flags are set. If this is set to Y (Yes), SA OS/390 checks each of the other flags to see if it is set to Y or N.
  - I** If this is on, automation issues the correct MVS start command for each subsystem when SA OS/390 is initialized and assures that subsystems are started in the order specified in the automation control file.
  - S** If this is on, automation manages and completes the startup process of subsystems.
  - R** If this is on, automation takes the specified action for any MVS message that is not associated with the initialization, startup, shutdown, or restart of a subsystem. For example, if this flag is on, automation takes actions to restart the subsystem in case of an abend.

- D** If this is on, automation manages the shutdown process for subsystems by issuing shutdown commands and responding to prompts for additional information.
- RS** If this is on, automation monitors subsystems to ensure that they are running and if one fails, attempts to restart it according to the policy in the automation control file.

Each flag has a value of:

**N** Off  
**E** User exit  
**Y** On  
**?** Error

- The TYPE field shows the type of job, either MVS, NONMVS, TRANS(ient), or ONESHOT.
- The Activity field shows whether the resource is in a starting or stopping process.

PF4 lets you toggle to the INGLIST command dialog showing the same resources from the automation manager view.

PF10 and PF11 let you scroll horizontally.

If you press PF11 on this panel, a panel similar to the following is displayed:

```

AOFKSTA5          SA OS/390 - Command Dialogs          Line 1 of 442
Domain ID = IPSFO ----- DISPSTAT -----          Date = 10/25/99
Operator ID = AFRANCK                                     Time = 11:41:24
 A ingauto B setstate C shutsys D thresholds E explain F info G tree
 H trigger I service J all children K children L all parents M parents
CMD  RESOURCE      STATUS      LAST CHANGED      LAST MONITORED
-----
AGFG      BROKEN      10/23/99 15:02:14 10/25/99 11:21:44
AGFG2     BROKEN      10/23/99 15:02:13 10/25/99 11:21:44
ANELSTP1  UP          10/23/99 15:02:47 10/25/99 10:22:43
ANELTEST  UP          10/23/99 15:02:54 10/25/99 10:22:43
ANEL0AA1  UP          10/23/99 15:02:50 10/25/99 11:21:44
ANEL00A1  UP          10/23/99 15:02:56 10/25/99 10:22:43
ANEL00B1  UP          10/23/99 15:02:45 10/25/99 10:22:43
ANEL00B2  UP          10/23/99 15:02:56 10/25/99 11:21:44
ANEL00B3  UP          10/23/99 15:02:56 10/25/99 11:21:44
ANEL00B4  UP          10/23/99 15:03:04 10/25/99 11:21:44
ANEL00B5  UP          10/23/99 15:02:53 10/25/99 11:21:44
ANEL00C1  UP          10/23/99 15:02:58 10/25/99 11:21:44
APPC      UP          10/23/99 15:02:12 10/25/99 11:21:44
ASCH      UP          10/23/99 15:02:12 10/25/99 11:21:44
BATB000P100 DOWN      10/23/99 15:02:14 10/25/99 11:21:44
BATB000P200 DOWN      10/23/99 15:02:14 10/25/99 11:21:44
BATB000P300 DOWN      10/23/99 15:02:15 10/25/99 11:21:44
BATB000S100 DOWN      10/23/99 15:02:18 10/25/99 11:21:44
BATB000S200 DOWN      10/23/99 15:02:17 10/25/99 11:21:44
BATB000S300 DOWN      10/23/99 15:02:17 10/25/99 11:21:44
BLSJPRMI  ENDED      10/23/99 15:02:12 10/25/99 11:21:44

Command ==>
PF1=Help   PF2=End   PF3=Return PF4=INGLIST PF5=Filters PF6=Ro11
            PF8=Forward PF9=Refresh PF10=Previous PF11=Next PF12=Retrieve

```

Figure 25. DISPSTAT Command Dialog Times Panel

- The RESOURCE field shows the name of the resource.
- The STATUS field shows the status of the resource.
- The LAST CHANGED field shows the date and time that the status of the subsystem last changed.

## DISPSTAT

- The LAST MONITORED field shows the time that the system was last monitored. If monitoring has been disabled this field is set to dashes.

If you press PF11 on this panel, a panel similar to the following is displayed:

```
A0FKSTA5          SA OS/390 - Command Dialogs          Line 1 of 442
Domain ID = IPSFO  ----- DISPSTAT -----          Date = 10/25/99
Operator ID = NETOP1                               Time = 11:59:07
 A ingauto B setstate C shutsys D thresholds E explain F info G tree
 H trigger I service J all children K children L all parents M parents
CMD  RESOURCE      STATUS      TRIGGER  SRVC PRD DESCRIPTION
-----
AGFG      BROKEN
AGFG2     BROKEN      none
ANELSTP1  UP          with
ANELTEST  UP          Used
ANEL0AA1  UP          For
ANEL00A1  UP          For
ANEL00B1  UP          Application
ANEL00B2  UP          For
ANEL00B3  UP          For
ANEL00B4  UP          For
ANEL00B5  UP          For
ANEL00C1  UP          For
APPC      UP          APPC/MVS
ASCH      UP          ASCH
BATB000P100 DOWN      Stop
BATB000P200 DOWN      =
BATB000P300 DOWN      Stop
BATB000S100 DOWN      Start
BATB000S200 DOWN      =
BATB000S300 DOWN      Start
BLSJPRMI  ENDED      none

Command ==>
PF1=Help   PF2=End     PF3=Return  PF4=INGLIST PF5=Filters PF6=Ro11
PF8=Forward PF9=Refresh PF10=Previous PF11=Next  PF12=Retrieve
```

Figure 26. DISPSTAT Command Dialog Description Panel

- The RESOURCE field shows the name of the resource.
- The STATUS field shows the status of the resource.
- The TRIGGER field shows the triggers that are defined for the subsystem (only shown if the resource is managed by SA OS/390 V1R3).
- The SRVC PRD field shows the service periods that are defined for the subsystem (only shown if the resource is managed by SA OS/390 V1R3). It is recommended that you use the INGLIST command to display the triggers and service periods.
- The DESCRIPTION field shows a description of the subsystem, from the automation control file.

Press PF11 to return to the first DISPSTAT panel.

Press PF5 to display the DISPSFLT panel. For a description of the DISPSFLT command refer to “DISPSFLT” on page 49.

## DISPSYS

### Purpose

The DISPSYS command displays information about the NetView automation agent setup.

Note that if no data is defined or it is not relevant, for example, the sysplex group name for a system not in a sysplex, the word 'none' is displayed in the appropriate field.

## Syntax

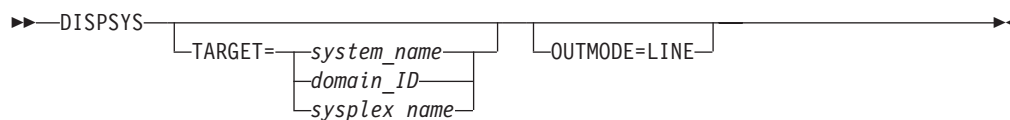

## Parameters

### TARGET

For information on the TARGET parameter, refer to “Additional Parameters for System Operations Commands” on page 10.

### OUTMODE

For information on the OUTMODE parameter, refer to “Additional Parameters for System Operations Commands” on page 10.

## Restrictions and Limitations

The DISPSYS command can only be used when SA OS/390 is initialized.

## Usage

DISPSYS is used when you wish to see the system parameters and SA OS/390 status information for the Sysplex Timer®.

## Examples

If you type `dispsys`, you see a panel similar to the following:

```

AOFKADAE                SA OS/390 - Command Dialogs      Line 1   of 39
Domain ID   = IPSFO      ----- DISPSYS -----      Date = 06/27/02
Operator ID = NETOP1     System = KEY3                  Time = 17:24:32

System          : KEY3                in Sysplex : KEY1PLEX
Domain          : IPSFO
Sysplex Group  : KEY1PLEX
XCF Group name : INGXSGA0

Software
  Operating System : z/OS 01.02.00
  NetView          : Tivoli NetView for OS/390 V1R4
  Tower(s)         : SA MSM GRAPHICS
  System Automation : V2R2M0

Configuration
  Data set        : SATEST.SAMPLE.ACF(ACFZ996)
  Built by        : TIL 06/26/02 09:03:42
  Activated       : 06/27/02 12:52:54
  CFG Token       : 20020626090342000915282064

Command ==>>
PF1=Help      PF2=End      PF3=Return      PF6=Roll
PF8=Forward   PF9=Refresh   PF12=Retrieve
  
```

Figure 27. DISPSYS Command Dialog Panel

For further details about the fields on the panel, refer to the customization dialog and to *System Automation for OS/390 Defining Automation Policy*.

## DISPTREE

### DISPTREE

#### Purpose

The DISPTREE command displays the dependency graph for a particular resource.

#### Syntax

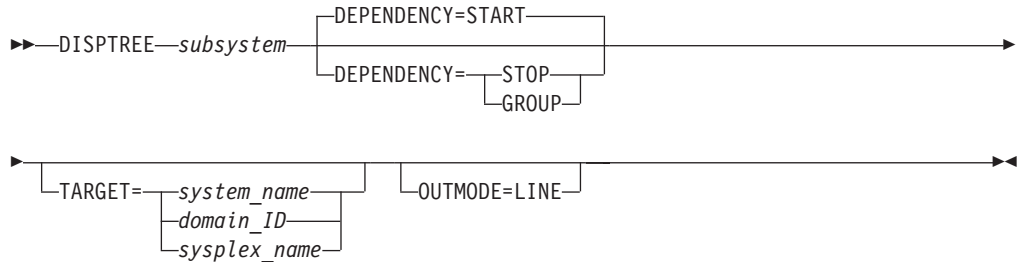

#### Parameters

##### *subsystem*

The name of the subsystem the display is to be focused upon.

##### DEPENDENCY

Specifies the type of dependency that should be used to draw the dependency graph. The following options are available:

##### START

The start relationship that is defined for the named subsystem will be used to draw the graph.

##### STOP

The stop relationship that is defined for the named subsystem will be used to draw the graph.

##### GROUP

The group relationship that is defined for the named subsystem will be used to draw the graph.

##### TARGET

For information on the TARGET parameter, refer to "Additional Parameters for System Operations Commands" on page 10.

##### OUTMODE

For information on the OUTMODE parameter, refer to "Additional Parameters for System Operations Commands" on page 10.

#### Restrictions and Limitations

The DISPTREE command can only be used when SA OS/390 is initialized.

#### Examples

If you type `disptree jes2`, a panel similar to the following is displayed:

```

AOFKTRREE          SA OS/390 - Command Dialogs          Line 1 of 78
Domain ID = IPSNO  ----- DISPTREE -----           Date = 07/19/00
Operator ID = NETOP1                               Time = 18:39:18

Subsystem ==> JES2      System ==> KEY3      Dependency ==> START

PCAUTH  --+
  AOCSSI  --+
    AOCAPPL  --+
      JES2
        +-- AMCP
        +-- ASTEX
        +-- DBUSS
        +-- IRRDPTAB
        +-- MIM
          |
          +-- TMS
            |
            +-- SLS
              |
              +-- HSM
        +-- OMIIHIST
          |
          +-- OMIIHDI
            |
            +-- OMIIEIE
              |
              +-- OMIICOL
                |
                +-- OMIICCOL
                  |
                  +-- OMIICCUA
        +-- PIRLM
          |
          +-- PIMS
            |
            +-- OMIIIPIMS
            +-- PIMSDBRC
            +-- PIMSDLI
        +-- PMO
        +-- QFETCHA
        +-- QFETCHB
        +-- QFETCHC
        +-- QFETCHD
        +-- RMF
          |
          +-- RMFGAT
        +-- RODM
          |
          +-- GMFHS
          +-- NETGMFLS

Command ==>
PF1=Help   PF2=End   PF3=Return   PF4=Focus   PF5=Info   PF6=Ro11
PF8=Forward PF9=Refresh   PF11=Right PF12=Retrieve

```

Figure 28. DISPTREE Sample Panel

- The Subsystem field shows the name of the subsystem
- The System field shows the name of the system where the subsystem resides
- The Dependency field shows the dependency type (START, STOP, or GROUP)

If you put the cursor next to a resource and press PF4 the tree structure of the resource is shown.

PF5 lets you toggle to the DISPINFO command dialog.

## DISPTRG

### Purpose

The DISPTRG command displays the trigger conditions of a subsystem.

### Syntax

```

▶▶ DISPTRG—resource—┬── TARGET=—system_name—┬── OUTMODE=LINE—┐
                       │                       │                       │
                       └── domain_ID—┬──┘
                                     └── sysplex_name—┘

```

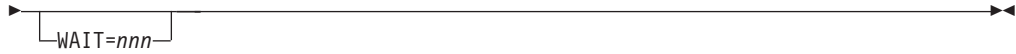

## Parameters

### *resource*

The name of the resource for which the trigger condition is displayed. The format is name/type[/system]. Wildcard is supported.

### TARGET

For information on the TARGET parameter, refer to “Additional Parameters for System Operations Commands” on page 10.

### OUTMODE

For information on the OUTMODE parameter, refer to “Additional Parameters for System Operations Commands” on page 10.

### WAIT

Specifies the number of seconds to wait before reporting that a timeout occurred if the automation manager does not provide the requested data. The maximum time interval is 999 seconds.

If omitted, the time interval is 30 seconds.

## Restrictions and Limitations

The DISPTRG command can only be used when SA OS/390 is initialized.

## Examples

If you type the name of a resource for which a trigger is defined, a panel similar to the following is displayed:

```

AOFLT000          SA OS/390 - Command Dialogs          Line 1 of 4
Domain ID = IPSFO  ----- DISPTRG -----          Date = 10/25/99
Operator ID = NETOP1      System = KEY3              Time = 13:26:58

Resource ==> TRGG006AA10/APL/KEY3
System ==> KEY3          System name, domain id or sysplex name
Trigger. . . : TRIGGER6

Cmd: S show details
Cmd Type      Events
-----
STARTUP      B000S100 B000S200
STARTUP      B000S300
SHUTDOWN     B000P100 B000P200
SHUTDOWN     B000P300

Command ==>
PF1=Help      PF2=End      PF3=Return   PF6=Ro11
               PF9=Refresh   PF12=Retrieve

```

Figure 29. DISPTRG Command Dialog Panel

- The Resource field shows the name of the resource that uses the trigger.
- The System field shows the name of the system where the subsystem is defined.
- The Trigger field shows the trigger that is defined for the subsystem.
- The Cmd field allows you to specify command codes. The following command code is available:

- S Shows details of the system defined.
- The Type field shows the type of the specified condition.
- The Events field shows the names of the specified events. Event that are satisfied are shown in white. Unset events are shown in red.

## DISPWTOR

### Purpose

The DISPWTOR command displays all currently outstanding WTORs. They are sorted by subsystem, with each subsystem's primary WTOR shown first, and then any secondary WTORs. The primary WTOR is the one that shutdown passes reply to. Secondary WTORs are shown in blue.

### Syntax

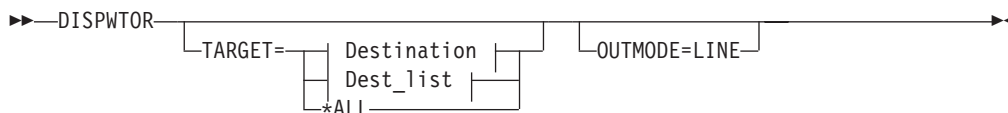

### Destination:



### Dest\_list:



### Parameters

#### TARGET

For information on the TARGET parameter, refer to “Additional Parameters for System Operations Commands” on page 10.

#### OUTMODE

For information on the OUTMODE parameter, refer to “Additional Parameters for System Operations Commands” on page 10.

### Restrictions and Limitations

The DISPWTOR command can only be used when SA OS/390 is initialized.

### Usage

DISPWTOR is used to determine what outstanding WTORs SA OS/390 has, or to find the reply for a specific subsystem. DISPWTOR differs from the SDF WTOR display in that the information shown is constructed from the global variables that SA OS/390 uses to keep track of current WTORs, and determine if it is possible to reply to one.

### Examples

If you type `dispwtor` you see a panel similar to the following:

## DISPWTOR

```

AOFKADAC          SA OS/390 - Command Dialogs          Line 1   of 2
Domain ID = IPSFP  ----- DISPWTOR -----          Date = 11/10/97
Operator ID = OPER1                               Time = 16:55:47

  Rply  System  Subsystem  Message
  -----
    64  KEY6    NETVIEW    DSI802A IPSFP REPLY WITH VALID NCCF
                                SYSTEM OPERATOR COMMAND

Command ==>
PF1=Help      PF2=End      PF3=Return    PF6=Roll
PF9=Refresh   PF12=Retrieve
  
```

Figure 30. Display of Outstanding Replies (DISPWTOR)

- The Rply field shows the outstanding reply number.
- The System field contains the value stored by OUTREP (AOFRSORP) from the NetView REXX variable sysid(), which is the ID of the MVS system that sent the message.
- The Subsystem field shows the subsystem name, or MVSESA if the reply is from a resource that is not a subsystem.
- The Message field shows the text of the message.

## DRAINJES

### Purpose

DRAINJES drains (halts) JES2 resources prior to JES2 shutdown. Specifically, DRAINJES issues commands to drain the initiators, syslog, offloader tasks, lines, printers, punches, and readers (depending on which resources are listed in the automation control file).

### Syntax

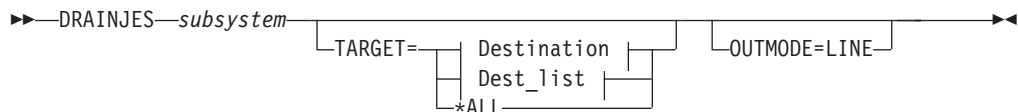

### Destination:

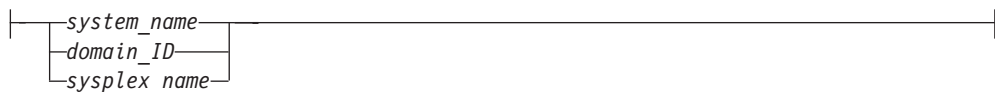

### Dest\_list:



### Parameters

*subsystem*

Specifies the name of the JES2 subsystem whose resources you want to drain.

If you are in full-screen mode and you do not specify a subsystem, a panel is displayed on which you can specify the subsystem. If you are in line mode an error message is displayed.

### TARGET

For information on the TARGET parameter, refer to “Additional Parameters for System Operations Commands” on page 10.

### OUTMODE

For information on the OUTMODE parameter, refer to “Additional Parameters for System Operations Commands” on page 10.

## Restrictions and Limitations

The DRAINJES command can only be used when SA OS/390 is initialized.

## Usage

Normally, you do not need to issue this command because it is performed automatically as part of the SHUTDOWN processing. However, if SA OS/390 is unable to shut down a particular JES2 subsystem, you can use DRAINJES.

## Examples

Assuming the JES2 subsystem name is JES2, type `drainjes jes2` to drain the JES2 resources.

## EXPLAIN

### Purpose

The EXPLAIN facility gives you a description of the automation statuses that can occur for SA OS/390 subsystems. It explains what the status means, why the subsystem may have got into the status, and how another status can be achieved.

### Syntax

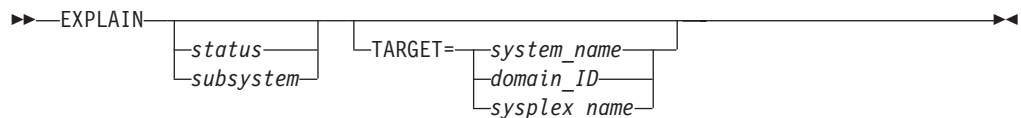

### Parameters

If you do not specify any parameters, a menu panel is displayed where you can specify either an automation manager status, automation agent status, or the name of a subsystem.

#### *status*

The status you want to see an explanation of.

#### *subsystem*

The name of the subsystem you are investigating. Its status is queried and an explanation of the automation agent status is displayed.

### TARGET

For information on the TARGET parameter, refer to “Additional Parameters for System Operations Commands” on page 10.

## Restrictions and Limitations

The EXPLAIN command can only be used when SA OS/390 is initialized.

## Usage

Use EXPLAIN when you want information about an automation status.

# EXPLAIN

## Examples

If you type EXPLAIN, a panel similar to the following is displayed:

```
AOFKEXPL          SA OS/390 - Command Dialogs
Domain ID   = IPSFO  ----- EXPLAIN -----   Date = 06/27/02
Operator ID = NETOP1                               Time = 17:28:26

Specify one of the following for a description of the corresponding status:

1. Agent status                               (? for list)
2. Automation manager status                   (? for list)
3. Subsystem name

Command ==>
PF1=Help    PF2=End    PF3=Return
PF6=Ro11    PF12=Retrieve
```

Figure 31. EXPLAIN Sample Panel

## GWTRACE

### Purpose

GWTRACE is used to enable and disable the GATEWAY debugging feature. When activated, all gateway requests are logged in the netlog through messages AOF665I and AOF666I.

If a notification operator is logged on with the debug message class (1), that operator also receives the trace messages.

The GWTRACE request can be routed to other domains.

### Syntax



### Parameters

If you do not specify any parameters, a panel is displayed upon which you enter parameters.

#### option

Specifies the trace option. This is either YES, NO, ON, or OFF.

#### todomain

Specifies the destination domain for the gateway trace. Defaults to the invoking domain.



## INGAMS

### REFRESH

Updates an automation manager with the definition data stored in the specified configuration file. This also reloads the appropriate ACFs on the active automation agents.

**Note:** INGAMS REFRESH does not delete globals that are associated with ENTRY TYPEs that were deleted from the policy database before the last build if those ENTRY TYPEs are not associated with a subsystem. However, if a keyword/value is removed from the ENTRY TYPE, this is a change to the E-T. Therefore, INGAMS REFRESH rebuilds the E-T and the deleted keyword/value pair is removed from the globals.

All deleted entry types and their associated globals will be reset during the next SA OS/390 COLD start or during ACF COLD processing.

### CFG=

The name of a partitioned data set holding the configuration file member as well as the ACF fragments. The name can be a fully qualified data set name or generation data group name. An asterisk (\*) can be used to indicate a reload of the previously used configuration file or a different generation of the previously used GDG.

*dsname*

Specifies a data set name.

*dsname (generation)*

Specifies the name of a generation data group (GDG) and the generation number (zero or signed integer) of a generation data set within the GDG.

*name*

Is the name of the automation manager.

### MODE=PAM

Specifies the mode of operation. The mode can be:

**PAM** Primary automation manager

### REQ

Is the function to be performed. It can be one of the following:

#### SNAPSHOT

Write a snapshot of automation manager data

#### STARTREC

Start recording

#### STOPREC

Stop recording

### DSN

Lets you specify the name of the data set that contains the snapshot or work item recording data. The output data set can be a sequential file or a member or a partitioned data set. However, if you want to record work items, you can only use a sequential file.

### TARGET

For information on the TARGET parameter, refer to "Additional Parameters for System Operations Commands" on page 10.

### OUTMODE

For information on the OUTMODE parameter, refer to "Additional Parameters for System Operations Commands" on page 10.

## Restrictions and Limitations

None.

## Usage

The INGAMS command operates sysplex-wide. For an overview refer to “Overview of Commands that Operate Sysplex-Wide” on page 9.

Automation manager commands are not supported on downlevel systems. Note that whenever an automation manager command is issued to a target system running an SA OS/390 Version lower than 2.1, the NetView error message DSI002I will not contain the name of the command that was issued but the name of the associated slave command.

When using the DIAG parameter make sure that the data set for writing a snapshot or for starting recording is online and free before issuing a command. The data set must be used exclusively by the automation manager (DISP=OLD) for making snapshots or for recording.

Use a partitioned data set (PDSE). The size of the PDSE should be defined according to the size specified in the snapshot size field under diagnostic info of the INGAMS panel.

## Examples

If you type ingams a panel similar to the following is displayed:

```

INGKYAM0                SA OS/390 - Command Dialogs          Line 1   of 2
Domain ID   = IPSF0     ----- INGAMS -----          Date = 06/27/02
Operator ID = NETOP1    Sysplex = KEY1PLEX              Time = 17:47:57

Cmd:  A Manage          B Show Details  C Refresh Configuration  D Diagnostic

Cmd  System  Member  Role  Status  Sysplex  XCF-Group  Release  Comm
---  -
KEY3  KEY3    KEY3    AGENT  READY  KEY1PLEX  INGXSGA0  V2R2M0  XCF
KEY3  KEY3    KEY3$$$1  PAM    READY  KEY1PLEX  INGXSGA0  V2R2M0  XCF

Command ==>
PF1=Help    PF2=End    PF3=Return  PF6=Ro11
PF9=Refresh  PF12=Retrieve
    
```

Figure 32. INGAMS Command Dialog Panel 1

- The CMD field allows you to specify command codes. To use one of the command codes shown, type the appropriate letter next to the resource name, and press Enter. The following command codes are available:
  - A Displays the change automation manager dialog panel, where you can modify the operation mode of the automation manager. You can make a secondary automation manager a primary one (SAM => PAM) and you can enable a takeover file.
  - B Displays additional information about the automation manager or

automation agent. For an automation agent, the DISPSYS command is issued to show details about the agent and the environment the agent runs on.

- C Displays the refresh configuration data panel. You need to enter the name of the data set containing the automation control file fragments and the configuration members.
- D Displays the utility panel where you can perform the following diagnostic functions:
  - Write snapshot
  - Start/stop recording

For further information refer to *System Automation for OS/390 User's Guide*.

- The System field shows the name of the system where an instance of the automation manager or automation agent runs.
- The Member field shows the name of the agent or manager. The name must be unique within the XCF group. The member name for an automation manager is automatically generated and consists of the OS/390 system name plus a 1-character suffix running from 1 to 9. The OS/390 system name is padded with '\$' to create an 8-character system name before appending the suffix.

**Note:** The member name of an automation agent is equal to the OS/390 system name.

- The Role field shows the type of the system. It can be one of the following:

<b>AGENT</b>	An automation agent
<b>PAM</b>	The primary automation manager
<b>SAM</b>	The secondary automation manager. There can be more than one.

- The Status field shows the status of the member. It can be one of the following:
  - blank** The status is unknown. This is always the case if you work with SA OS/390 V1R3.

**NOT READY**  
The automation agent or manager is initializing

**READY**  
The member is completely initialized

**PENDING**  
Indicates that the automation manager is in the process of initializing as a primary automation manager (PAM)

**SELECTED**  
The automation manager is selected to become the next primary automation manager (PAM)

**STOPPING**  
The automation manager is terminating

**REFRESH**  
Indicates that the automation manager performs a configuration refresh

**COMM**  
Is the type of communication being used between the automation manager and the automation agent.

- The Sysplex field shows the name of the sysplex.
- The XCF-Group field shows the name of the associated XCF-Group.
- The Release field shows the SA OS/390 Version and Release of the automation manager or automation agent.

The FIND/RFIND/SORT commands are supported. Refer to “Deciding the Format of the Command Output (Full-Screen only)” on page 13 for information.

### Changing the Automation Manager’s Operation Mode

When you enter command code A for a secondary automation manager, a panel is displayed where you can specify the new mode of operation. Switching into primary mode is considered a directed takeover.

```

INGKYAM1                SA OS/390 - Command Dialogs
Domain ID = IPSFM      ----- INGAMS -----      Date = 07/18/02
Operator ID = NETOP1   Sysplex = KEY1PLEX          Time = 14:47:43

Specify or revise the following data:

Action ==>             1. Make primary Automation manager (PAM)
                       2. Enable Takeover File

Automation manager ==> KEY1
System                ==>           System name, domain id or sysplex name

Command ==>
PF1=Help             PF2=End           PF3=Return
                                           PF6=Ro11
                                           PF12=Retrieve

```

Figure 33. INGAMS Command Dialog Panel 2

### Showing Details about the Automation Manager

When you enter command code B for an automation manager, a panel similar to the following is displayed:

```

INGKYAM3          SA OS/390 - Command Dialogs          Line 1   of 18
Domain ID   = IPSFO   ----- INGAMS -----          Date = 12/10/99
Operator ID = NETOP1          Sysplex = KEY1PLEX          Time = 12:27:18

Automation Manager : KEY3$$$1          running on system : KEY3
Operation mode     : PAM
Status            : READY
XCF-Groupname     : INGXSG

Logic Deck ...
Release           : V2R1M0
Date built        : 3 Dec 1999
Time built        : 12:17:47
Last APAR         : NONE

Config dataset name : SATEST.TEST.IPUFM.PROD.ACF
Config member      : HSAZ997
                  Z999CLGC  STRUCTURE  19991203152922
                  Z997CSCH  SCHEDULE   19991209142557
                  Z997CRES  STRUCTURE  19991209142557

Command ==>
PF1=Help      PF2=End      PF3=Return      PF6=Ro11
               PF8=Forward  PF9=Refresh     PF12=Retrieve
    
```

Figure 34. INGAMS Command Dialog Panel 3

### Refreshing the Configuration Data Sysplex-wide

When you enter command code C for an automation manager, a panel similar to the following panel is displayed

```

INGKYAM2          SA OS/390 - Command Dialogs          Date = 12/10/99
Domain ID   = IPSFO   ----- INGAMS -----          Time = 13:59:51
Operator ID = NETOP1          Sysplex = KEY1PLEX

Specify or revise the following data:

Configuration data set name (* for current data set)

                *(-1) _____

System          ==>  _____ System name, domain id or sysplex name

Command ==>
PF1=Help      PF2=End      PF3=Return      PF6=Ro11
               PF8=Forward  PF9=Refresh     PF12=Retrieve
    
```

Figure 35. INGAMS Command Dialog Panel 4

- In the System field specify the name of the system where the automation manager resides. Specifying this is only necessary if the automation manager is not within the local sysplex. You can specify either the system name, the domain, or the sysplex name.
- In the Configuration data set name field specify the name of the data set containing the automation manager configuration members. The name can be a fully qualified data set name or a generation data group name. You can use \* to

indicate a reload of the configuration from the data set that was used previously, or a different generation of the previously used GDG.

## INGAUTO

### Purpose

The INGAUTO command lets you turn the automation flags on or off for a specific resource, or for DEFAULTS, MVSESA or SUBSYSTEM for a specified time period after which they will automatically be turned on again. INGAUTO enables you to change a resource's assist mode settings.

### Syntax

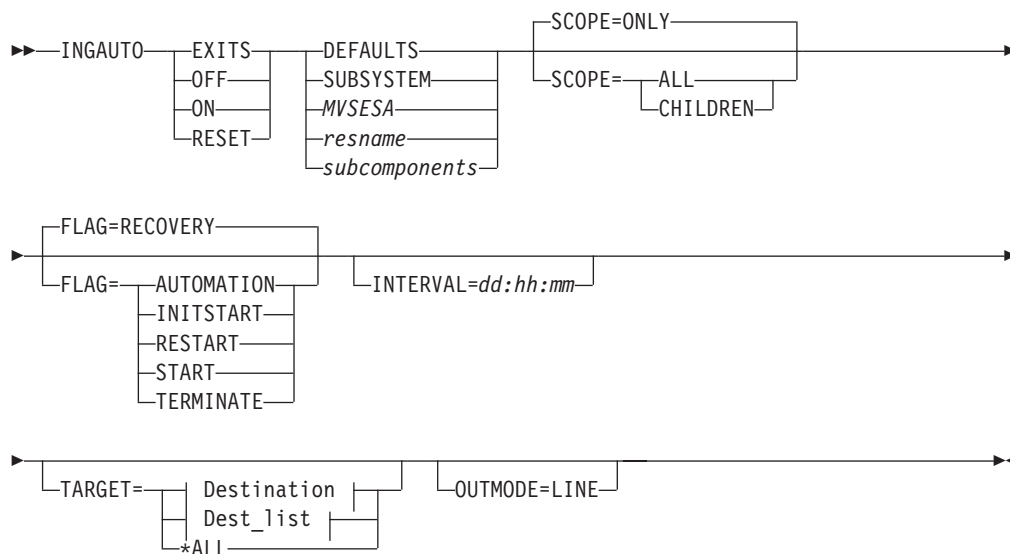

### Destination:



### Dest\_list:



### Parameters

If you do not specify a subsystem, a menu is displayed on which you can specify the subsystem.

#### EXITS

Enables user exits for the flag you specify.

#### OFF

Sets the automation flag you specify off.

## INGAUTO

### ON

Sets the automation flag you specify on.

### RESET

Resets the automation flag you specify to the values in your automation control file.

### DEFAULTS

Specifies the value DEFAULTS. This sets automation flags for all resources that do not have their own flags defined.

### SUBSYSTEM

Sets defaults for all subsystems.

### MVSESA

Sets defaults for all MVS subcomponents.

### *resname*

Specifies the name of a particular resource, for example, WTOBUF. You can specify any automated resource.

### *subcomponents*

Specifies the subcomponents of the resource. Enter a period (.) between each subcomponent name.

### SCOPE

Specifies whether to change automation for this resource and its dependent resources, dependent resources only, or this resource alone. Valid options are the following:

#### ONLY

Specifies this resource alone. This is the default.

#### ALL

Specifies this resource and its dependent resources.

#### CHILDREN

Specifies dependent resources only.

### FLAG

Specifies the automation flags to set on, off, reset, or enable a user exit for, (depending on whether you specified INGAUTO ON, OFF, RESET or EXITS). Refer to *System Automation for OS/390 Customizing and Programming* for further information on automation flags. Valid options are the following:

#### AUTOMATION

This sets the Automation flag, which is the controlling flag. If you set the Automation flag OFF, SA OS/390 turns all automation off. If the Automation flag is ON, SA OS/390 checks the other flags.

#### INITSTART

Sets the Initstart flag.

#### RECOVERY

Sets the Recovery flag.

#### RESTART

Sets the Restart flag.

#### START

Sets the Start flag.

#### TERMINATE

Sets the Shutdown flag.

**INTERVAL=dd:hh:mm**

Specifies the period of time the flag will be changed for.

At the end of the interval, the flag is reset to the state defined in the automation control file.

If no interval is specified, the flag is changed indefinitely.

**TARGET**

For information on the TARGET parameter, refer to “Additional Parameters for System Operations Commands” on page 10.

**OUTMODE**

For information on the OUTMODE parameter, refer to “Additional Parameters for System Operations Commands” on page 10.

**Restrictions and Limitations**

The INGAUTO command can only be used when SA OS/390 is initialized.

**Usage**

If the Automation flag is currently set to off, and you have changed one of the other flags, your change will not be effective until the Automation flag is set on. Occurrences will be detailed in the netlog.

If you have selected EXITS for an automation flag, and none have been specified in your automation control file, automation will be set to on. Occurrences will be detailed in the netlog.

SCOPE=ONLY is the only valid scope for DEFAULTS, resource type, and subcomponents. ALL and CHILDREN are not valid.

Make sure you specify the correct subcomponent name. Even if you specify a subcomponent that does not exist, the message FUNCTION SUCCESSFULLY COMPLETED will appear.

**Examples**

To turn all automation on in SA OS/390 for TSO, and for 2 hours only, type the following:

```
ingauto on,tso,flag=automation,interval=00:02:00
```

To turn all automation on for the WTOR buffer shortage recovery, type the following:

```
ingauto on,mvsesa.wto
```

**INGCF****Purpose**

The INGCF command supports all the functions of SA OS/390 that deal with coupling facilities. It supports full mode and line mode—for full line mode capability, refer to “INGCFL” on page 91. If you issue INGCF in line mode, only the display function is available.

The INGCF command supports the following parameters:

- DRAIN

Serves to remove all allocated structures from the coupling facility, to disconnect the coupling facility from the systems of the sysplex, and to inactivate the coupling facility.

- ENABLE

## INGCF

Serves to activate a coupling facility, connect it with the systems of a sysplex and to populate it with structures.

- **PATH**  
Displays and controls the sender paths of the target coupling facility. It sets the sender paths ONLINE and OFFLINE physically and logically.
- **STRUCTURE**  
Displays detail information and rebuilds or deletes a selected structure on the target coupling facility. It also lets you start and stop duplexing.

INGCF associates a status with every coupling facility, and a condition with every structure (instance) that is allocated on the target coupling facility. The structure condition is influenced by the release level of the system that allocated the structure. The INGC functions use the coupling facility state and the structure conditions to determine which action can be performed in any given situation. Therefore, the DRAIN and ENABLE functions can enforce a correct sequence of actions for complex tasks such as draining or restoring a coupling facility.

If the selected action impacts the sysplex configuration it must be confirmed before execution.

### Authorizations

The actions that you can initiate with INGC depend on your authorizations. The panels show your authorization type. Note that the authorization types apply to the current function, and that your authorization type can be different for different functions.

The following authorization types exist:

#### DISPLAY

You cannot initiate any action that affects the sysplex configuration.

#### ALL BUT (ACTIVATE | SHUTDOWN)

This type only occurs in the DRAIN and ENABLE command dialogs. You can rebuild structures, force the deletion of structures and set the sender paths offline and online, but you cannot inactivate or activate the coupling facility.

**ALL** You can initiate all actions from the corresponding panel.

Depending on your authorizations, it is possible that you have, for example, authorization type ALL for the STRUCTURE function, and authorization type DISPLAY for the DRAIN function.

### Syntax

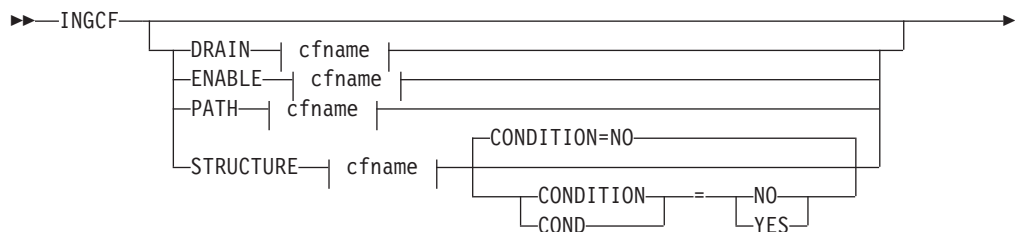

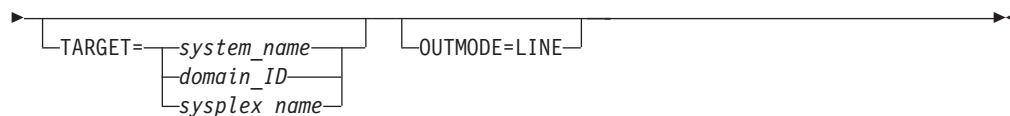

**cfname:**

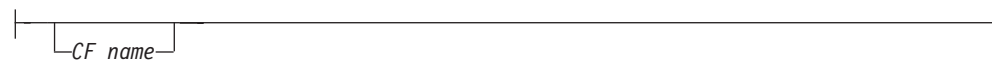

## Parameters

### DRAIN

Prepares a coupling facility for removal from the sysplex.

### ENABLE

(Re)integrates a coupling facility into a sysplex.

### PATH

Controls the sender paths of a coupling facility.

### STRUCTURE

Offers manipulation of individual structures (detail information, rebuild, deletion).

### *CF\_name*

Name of the target coupling facility for the specified function. The default is a selection panel that shows all available coupling facilities of the sysplex.

### CONDITION

Specify YES if you want to get the current condition for each structure. Selecting this option increases the response time required to build the display. The default is NO.

### TARGET

For information on the TARGET parameter, refer to “Additional Parameters for System Operations Commands” on page 10.

### OUTMODE

For information on the OUTMODE parameter, refer to “Additional Parameters for System Operations Commands” on page 10.

## Restrictions and Limitations

The ENABLE and the PATH functions require that the active IODF is catalogued. Otherwise, sender path information cannot be retrieved in certain situations.

INGCF ENABLE assumes that the receiver paths from the coupling facility to the systems of the sysplex have been defined and activated. This requires a POR of the CPC on which the coupling facility resides.

## Coupling Facility States

The status of a coupling facility can be as follows:

### ACTIVATING

The coupling facility is being activated and will then become DRAINED.

### DEACTIVATING

The coupling facility is being deactivated and will then become INACTIVE.

### DRAINING

The coupling facility is being disconnected from the connected systems.

### **DRAINED**

The coupling facility has no connection to any system and can be removed from the sysplex.

### **DRAINED NOHWACC**

The coupling facility has no connection to any system, but cannot be removed from the sysplex because the BCP (Basic Control Program) internal interface is not available.

**Note:** This status is also displayed when the coupling facility has been deactivated from the HMC (Hardware Management Console) but the XCF display commands still return the name of the coupling facility.

### **ENABLING**

The coupling facility is being connected to the systems of the sysplex that use it.

### **FORCING**

Allocated structures are being deleted from the coupling facility. This only happens with structures that have no active connectors, and with these only when they cannot be rebuilt by system-managed rebuild.

### **INACTIVE**

The coupling facility is not active.

### **INACTIVE NOHWACC**

The coupling facility is not active and cannot be activated because the BCP Internal Interface is not available.

### **NORMAL**

The coupling facility may have allocated structures and is connected to all systems.

### **NORMAL OFFLINE**

The coupling facility may have allocated structures. At least one system has set all its sender paths to this coupling facility to OFFLINE. XES will reject any rebuild request for this coupling facility.

### **NOTINPOLICY**

The coupling facility is active but not defined in the active CFRM policy.

### **POPULATING**

The coupling facility is being populated with all those structures that have it on the first place in their preference list.

### **REBUILDING**

Either all allocated structures that can be rebuilt are being removed from the coupling facility by the XES rebuild process (initiated by DRAIN), or one particular such structure is being removed (initiated by the STRUCTURE).

## **Structure Conditions**

The condition of an allocated structure can be:

### **Rebuild is not supported.**

The structure can neither be rebuilt, nor can its deletion be forced.

The structure has at least one active connector that does not support user-managed rebuild, and at least one active connector that does not support system-managed rebuild.

**System-managed processes not supported.**

The structure cannot be rebuilt, nor can its deletion be forced.

System-managed rebuild, which is a system-managed process, is not possible for one of the following reasons:

- The structure was allocated from a system with OS/390 2.7 or below.
- The CFRM couple data sets have not been formatted to support system-managed processes (ITEM NAME(SMREBLD) NUMBER(1) was not specified.).

**Note:** In certain rare cases system-managed processes are not supported although the condition that is displayed on the DRAIN panel seems to indicate the contrary. Then, the rebuild will be initiated, but will fail with message IXC367I indicating that system-managed processes are not supported for the structure.

**No alternate coupling facility defined or available.**

The structure can neither be rebuilt, nor can its deletion be forced.

The structure has an active connector and supports rebuild but has no alternate coupling facility defined in its preference list, or the alternate coupling facilities defined in the preference list are currently unavailable.

**Insufficient space detected for rebuild.**

The structure can or could not be rebuilt. Its deletion cannot be forced.

No alternate coupling facility has enough space to rebuild the structure.

**Preference list is empty.**

The structure cannot be rebuilt because its preference list is currently empty. A possible reason for this is a pending policy change; for pending policy changes, see "P column" on page 91.

**Structure is pending deallocation.**

XES accepted a forced deletion of the structure but does the real deallocation later.

**Note:** This status can only occur when MVS APAR OW39404 has not been installed.

**Structure is being rebuilt.**

The structure is being rebuilt to another coupling facility.

**Duplex rebuild is being stopped.**

Two instances of the structure were maintained on different coupling facilities. The application is being disconnected from that instance that is allocated on the target coupling facility. After disconnecting, the instance is deleted.

**No connection exists.**

The structure cannot be rebuilt, but you can force its deletion.

The structure has no connections and cannot be rebuilt with system-managed rebuild.

**No alternate coupling facility for structure with no connections.**

The structure cannot be rebuilt, but you can force its deletion.

The structure has no connections. It could be rebuilt with system-managed rebuild, but no alternate coupling facility is defined in its preference list or available.

**No alternate coupling facility for structure with no active connections.**

The structure cannot be rebuilt, but you can force its deletion.

The structure has only DISCONNECTING, FAILED, or FAILED-PERSISTENT connections. It could be rebuilt with system-managed rebuild, but no alternate coupling facility is defined in its preference list or available.

**The structure's initial size is less than its actual size.**

The structure can be rebuilt, but this can lead to loss of data.

An initial size is specified for the structure in the active CFRM policy. This initial size was used for the allocation of the structure. Afterwards, the size of the structure was increased either by the application itself or an operator command. However, the structure will only be rebuilt with its initial size. Subsequently, INGCf will expand the structure to its actual size again, but this will happen *after* the data have been transferred. To avoid a potential loss of data, the application has to change the initial size to the actual size.

**No active connection exists.**

The structure cannot be rebuilt, but you can force its deletion.

The structure has only DISCONNECTING, FAILED, or FAILED-PERSISTENT connections and cannot be rebuilt with system-managed rebuild.

**Note:** INGCf DRAIN deallocates structures with this condition as part of the REBUILD action (see "REBUILD (F10)" on page 80). INGCf STRUCTURE accepts a rebuild request for structures with this condition, but deallocates them (see "Rebuild (R)" on page 90).

**No connections. System-managed rebuild supported.**

The structure can be rebuilt.

The structure has no connections, but can be rebuilt with system-managed rebuild.

**No active connections. System-managed rebuild supported.**

The structure can be rebuilt with system-managed rebuild.

User-managed rebuild is not possible for the structure because it has only DISCONNECTING, FAILED, or FAILED-PERSISTENT connections.

**System-managed rebuild is supported**

The structure can be rebuilt.

The structure has active connectors. At least one active connector does not support user-managed rebuild, but all active connectors support system-managed rebuild.

**Duplex rebuild is active.**

The application is connected to two instances of the same structure on different coupling facilities.

**[No condition]**

When no condition is displayed, the structure can be rebuilt.

The structure has at least one active connection, and all its active connectors support user-managed rebuild.

**Structure is awaiting rebuild.**

The structure has been selected for rebuild but has not been processed yet.

**Structure is currently allocated on *cf\_name*.**

The structure can be rebuilt on the target coupling facility with the POPULATE action of the ENABLE function. It is currently allocated on the *cf\_name* coupling facility, but the target coupling facility precedes *cf\_name* in the structure's preference list. This condition is displayed only in the ENABLE command dialog.

**Structure allocated in *cf\_name* cannot be rebuilt to this CF.**

The structure can probably not be rebuilt on the target CF with the POPULATE action of the ENABLE function. It is currently allocated in the *cf\_name* CF, but the target CF precedes *cf\_name* in the structure's preference list. And, the actual size of the structure is greater than the free space of the target CF. This condition is displayed only in the ENABLE command dialog.

**Example**

If you issue INGCF without any parameters, a panel with all coupling facilities of the sysplex is displayed:

```

INGLX900          SA OS/390 - Command Dialogs      Line 1 of 2
Domain Id   = IPSF0          ----- INGCF -----      Date = 02/23/03
Operator Id = NETOP1                               Time = 13:42:35

Sysplex . . . . . : KEY1PLEX          SM process level . : 12
-----
Cmds: D drain CF / E enable CF / P display sender paths / S display structures

  CF Name  Total Space Free Space Free% V Lvl LP Node Descriptor
-----
_ CF01      507392 K   446976 K 88.09 Y  11  D 009672.RX6.IBM.51.000000064516
_ CF02      245248 K   210944 K 86.01 Y  11  E 009672.RX6.IBM.51.000000064516

Command ==>
F1=Help      F2=End          F3=Return      F6=Ro11
              F9=Refresh      F12=Retrieve

```

Figure 36. INGCF Selection Panel

Specify a function for a selected coupling facility and press Enter.

**DRAIN**

**Purpose:** The DRAIN function of INGCF facilitates the removal of a coupling facility from the sysplex, for example, for maintenance purposes. With this option, you can perform the following sequence of tasks:

1. Display information for all allocated structures of the coupling facility.
2. Rebuild all rebuildable structures on *another* coupling facility, and delete instances of structures on the target coupling facility that are being duplexed on another coupling facility.

**Notes:**

- a. The scope of the structures that can be rebuilt depends on the release level of the sysplex members.

## INGCF DRAIN

- b. INGCF DRAIN rebuilds structures one at a time (SETXCF START,REBUILD,STRNAME=), not globally (SETXCF START,REBUILD,CFNAME=), and always on a coupling facility that is different from the target coupling facility (LOCATION=OTHER).
  - c. Generally, you should be aware that it is XES that performs the actual rebuild. Not all of the factors that XES takes into account when allocating a structure are accessible to SA OS/390. Therefore, a rebuild request for a structure that should be rebuildable according to its condition can fail in certain rare cases.
3. Force the deletion of structures that have no active connectors and cannot be rebuilt.

Note that there are structures that you can neither rebuild nor delete with the force action. These include the structures that have at least one active connector and do not support rebuild. To remove such structures first disconnect all active connectors, and then delete the structure manually if it is persistent or has persistent connections.

4. Disconnect the coupling facility from the systems with which it is connected.
5. Inactivate the target coupling facility.

INGCF DRAIN ensures that these actions are performed in the correct order, as specified above.

**Actions:** The following F-keys are supported:

### \*REBUILD (F10)

Starts the rebuild of structures that can be rebuilt on *another* coupling facility. Thus, a rebuild is only initiated for structures whose preference list contains more than one coupling facility.

There are two methods for rebuild, user-managed and system-managed rebuild. User-managed rebuild is supported for all release levels. System-managed rebuild is only available with systems that have OS/390 2.8 or above; it must have been enabled by formatting the CFRM couple data sets with the specification

```
ITEM NAME(SMREBLD) NUMBER(1)
```

System-managed rebuild is only performed when the requirements for user-managed rebuild are not met. This applies, for example, to structures without active connectors.

The REBUILD action also deletes all structure instances on the target coupling facility that are being duplexed on another coupling facility.

**Note:** The REBUILD action *deallocates* structures with the condition 'No active connection exists.'. See "No active connection exists" on page 78.

### \*FORCE (F5)

Forces the deallocation of structures with one of the following conditions:

- No connection exists.
- No alternate coupling facility for structure with no active connections.
- No alternate coupling facility for structure with no connections.

This action is only made available after all structures that can be rebuilt have been rebuilt.

**\*DRAIN (F4)**

Disconnects the coupling facility from its connected systems by setting the sender path(s) OFFLINE.

This action is only enabled after all structures of the target coupling facility have been removed to another coupling facility or deallocated. Note that structures that have active connectors but do not support rebuild cannot be removed with F10 or F5. They must be deallocated manually before executing this step is enabled.

**\*SHUTDOWN (F11)**

This action inactivates the coupling facility. It is only made available when all connections between the coupling facility and the systems of the sysplex have been disconnected.

**Note:** This function key is unavailable when running on a z/OS image which runs under z/VM.

Note that these actions can only be performed if INGC F DRAIN is issued in full mode. In line mode, only the display function is available.

To avoid performance degradation due to multiple rebuild processes, or unpredictable results due to multiple executions of an action, all actions are locked. Therefore, an action is rejected if any lock exists even if the action does not affect the action currently being performed. Because the action can take a long time it is also executed asynchronously on a dedicated autotask, preventing the operator from being blocked. To check progress, use the refresh function (F9).

**Example:** In the following example, a coupling facility is drained:

1. All of its structures that can be rebuilt are rebuilt on another coupling facility, and duplexing is stopped.
2. For all structures that have no active connector and cannot be rebuilt deletion is forced.
3. All systems that are connected with the coupling facility are disconnected.
4. The coupling facility is inactivated.

When you issue INGC F with the option DRAIN, you can specify the coupling facility to be drained, for example by entering INGC F DRAIN CF01; in this case, the panel of Figure 37 on page 82 is displayed at once. If you do not specify a coupling facility name, INGC F displays a selection panel with all coupling facilities that are defined in the sysplex. After selection of CF01, INGC F displays the following panel:

## INGCF DRAIN

```

INGLX901          SA OS/390 - Command Dialogs      Line 1 of 31
Domain Id   = IPSFO      ----- INGCF DRAIN -----      Date = 02/13/01
Operator Id = NETOP1                                Time = 07:01:00

Coupling Facility ==> CF01          Status . . . . . : NORMAL
Sysplex . . . . . ==> KEY1PLEX      Permission . . . . . : ALL
-----
Structure      Condition
-----
DFHXQLS_TESTTSQ1 No active connections. System-managed rebuild supported.
DSNG_LOCK1
DSNG_SCA          System-managed rebuild is supported.
ISGLOCK
ISTGENERIC
IXCGRS
IXCplex_PATH1
M7SG_LOCK1      *No alternate CF for structure with no active connections.
M7SGEMHQ        No active connections. System-managed rebuild supported.
M7SGMSGQ        No active connections. System-managed rebuild supported.
M7SGMSGQOV      No active connections. System-managed rebuild supported.

Command ==>
F1=Help          F2=End          F3=Return          F6=Ro11
                  F8=Forward      F9=Refresh      F10=Rebuild          F12=Retrieve

```

Figure 37. DRAIN Command Dialog Panel: Before any Action

The status of the coupling facility (NORMAL) and the authorization type of the operator (ALL) are displayed on the right side of the panel header. The main part of the panel consists of a list containing the structures allocated in CF01 and their conditions. The conditions are classified by color and an asterisk. The asterisk signifies that a structure cannot be rebuilt.

The only action that is enabled is REBUILD with F10. Pressing F10 calls the following confirmation panel:

```

INGLX92R          SA OS/390 - Command Dialogs      Date = 02/13/01
Domain Id   = IPSFO      ----- INGCF DRAIN -----      Time = 07:01:04
Operator Id = NETOP1

Coupling Facility . : CF01
Sysplex . . . . . : KEY1PLEX

                R E B U I L D Confirmation

The REBUILD process runs asynchronously on the next system in the sysplex that
has access to the CFRM couple data set and can perform all necessary actions.
Each structure that has no * indicator in front of its status is rebuilt to its
status accordingly. The structures are processed in sequence. Once started use
the refresh PF key for getting the current status of the process. When more
than one structure is being rebuilt a timeout occurred indicating that XCF is
very busy. But processing continues. A display without any structure or only
structures that cannot be rebuilt indicates a successful completion.

Command ==>
                  F2=End          F3=Return          F6=Ro11
                  F10=Go          F11=Cancel          F12=Retrieve

```

Figure 38. DRAIN Command Dialog: Confirmation Panel for REBUILD

After F10 was pressed and the rebuild is complete the command dialog can be refreshed with F9. It looks as follows:

```

INGLX901          SA OS/390 - Command Dialogs      Line 1 of 1
Domain Id   = IPSFO      ----- INGCF DRAIN -----      Date = 02/13/01
Operator Id = NETOP1                                          Time = 07:53:36

Coupling Facility ==> CF01          Status . . . . . : NORMAL
Sysplex . . . . . ==> KEY1PLEX      Permission . . . . . : ALL
-----
Structure      Condition
-----
M7SG_LOCK1     *No alternate CF for structure with no active connections.

Command ==>
F1=Help      F2=End      F3=Return      F5=Force      F6=Roll
F9=Refresh                                       F12=Retrieve
    
```

Figure 39. DRAIN Command Dialog Panel: After Rebuild

One structure could not be rebuilt because no alternate coupling facility is specified in its preference list. The REBUILD action is no longer available. Instead, the FORCE action (F5) is available because the structure that could not be rebuilt has a condition that allows forcing the deallocation of the structure. Pressing F5 calls a confirmation panel similar to that for REBUILD. Pressing F10 on the confirmation panel and refreshing the command dialog after the action has been completed results in the following panel:

```

INGLX901          SA OS/390 - Command Dialogs      Line
Domain Id   = IPSFO      ----- INGCF DRAIN -----      Date = 02/13/01
Operator Id = NETOP1                                          Time = 08:12:28

Coupling Facility ==> CF01          Status . . . . . : NORMAL
Sysplex . . . . . ==> KEY1PLEX      Permission . . . . . : ALL
-----
Structure      Condition
-----

Command ==>
F1=Help      F2=End      F3=Return      F4=Drain      F6=Roll
F9=Refresh                                       F12=Retrieve
    
```

Figure 40. DRAIN Command Dialog Panel: After Forcing

No more structures are allocated in the coupling facility, so that the coupling facility can be released from the connections with the systems of the sysplex. Consequently, INGCF DRAIN enables the DRAIN action (F4). After completion of

## INGCF DRAIN

that action, the status of the coupling facility changes to DRAINED, as shown on the following panel:

```
INGLX901          SA OS/390 - Command Dialogs      Line
Domain Id   = IPSFO      ----- INGCF DRAIN -----      Date = 02/13/01
Operator Id = NETOP1                                Time = 08:12:32

Coupling Facility ==> CF01          Status . . . . . : DRAINED
Sysplex . . . . . ==> KEY1PLEX      Permission . . . . : ALL
-----
Structure      Condition
-----

Command ==>
F1=Help      F2=End      F3=Return      F6=Ro11
F9=Refresh      F11=Shutdown  F12=Retrieve
```

Figure 41. DRAIN Command Dialog Panel: After Draining

Because the coupling facility is no longer connected to any system, it can be inactivated. After pressing F11 the status of the coupling facility changes to INACTIVE:

```
INGLX901          SA OS/390 - Command Dialogs      Line
Domain Id   = IPSFO      ----- INGCF DRAIN -----      Date = 02/13/01
Operator Id = NETOP1                                Time = 08:12:32

Coupling Facility ==> CF01          Status . . . . . : INACTIVE
Sysplex . . . . . ==> KEY1PLEX      Permission . . . . : ALL
-----
Structure      Condition
-----

Command ==>
F1=Help      F2=End      F3=Return      F6=Ro11
F9=Refresh      F11=Shutdown  F12=Retrieve
```

Figure 42. DRAIN Command Dialog Panel: After Inactivation

## ENABLE

**Purpose:** The ENABLE function of the INGCF command is intended to support the integration AND re-integration of a coupling facility into a sysplex. With this option, you can:

1. Activate the target coupling facility.

2. Connect the systems of the sysplex with the coupling facility.
3. Switch to another CFRM policy if the target coupling facility is not defined in the active policy and a suitable policy is available.  
A suitable CFRM policy must contain:
  - A definition of the target coupling facility
  - Appropriate definitions for every active coupling facility and every allocated structure
4. Rebuild all structures on the target coupling facility whose preference list starts with this coupling facility, unless this is excluded by other requirements.

INGCF ENABLE ensures that these actions are performed in the correct order, as specified above.

**Actions:** The possible actions and the associated F-keys are:

**\*ACTIVATE (F11)**

This action activates the CFCC (Coupling Facility Control Code) through the BCP Internal Interface by an ACTIVATE command.

**Note:** This function key is unavailable when running on a z/OS image which runs under z/VM.

**\*ENABLE (F4)**

Sets the sender path(s) of all systems of the sysplex to ONLINE. This action is enabled when the coupling facility is active.

**\*SWITCH (F5)**

Switches to another CFRM policy when the target coupling facility is not defined in the active CFRM policy and a suitable policy is available. When there is more than one suitable policy you can choose one of these from a selection panel.

A CFRM policy is suitable when it contains:

- A definition of the target coupling facility
- Definitions for every active coupling facility and every allocated structure

This action is only made available when the target coupling facility is active, but not defined in the current CFRM policy.

**\*POPULATE (F10)**

Starts a rebuild process by which all structures that have the target coupling facility at the beginning of their preference list but are currently allocated on another coupling facility are allocated on the target coupling facility.

This action requires that the coupling facility be enabled, connected to all members of the sysplex, and defined in the current CFRM policy. The action is offered whenever INGC F ENABLE detects that a structure is not allocated on the target coupling facility although it is the preferred coupling facility of that structure.

**Note:** When you have drained a coupling facility with INGC F DRAIN and then reintegrate it with INGC F ENABLE, be aware that the set of structures that are allocated on the target coupling facility after population can be different from the original set before the draining. Typically, this happens when the original set does not contain

## INGCF ENABLE

exactly those structures that have the target coupling facility at the first position in their preference list.

Note that these actions can only be performed when INGC F ENABLE is called in full mode. In line mode, only the display function is available.

**Example:** In the following example, a coupling facility that has already been activated is reintegrated into the sysplex in two steps:

1. The coupling facility is connected to all systems of the sysplex.
2. All structures that have the target coupling facility as the first coupling facility in their preference list are allocated on the target coupling facility.

If you issue INGC F with the option ENABLE, you can specify the coupling facility to be reintegrated, for example by entering INGC F ENABLE CF02. In this case, the panel of Figure 43 is displayed at once. If you do not specify a coupling facility name, INGC F shows a selection panel with all coupling facilities that are defined in the sysplex. After selection of CF02, INGC F displays the following panel:

```
INGLX901          SA OS/390 - Command Dialogs          Line
Domain Id = IPSFO  ----- INGC F ENABLE -----      Date = 02/20/01
Operator Id = NETOP1                                     Time = 11:06:06

Coupling Facility ==> CF02          Status . . . . . : DRAINED
Sysplex . . . . . ==> KEY1PLEX      Permission . . . . . : ALL
-----
Structure          Condition
-----

Command ==>
F1=Help           F2=End           F3=Return       F4=Enable
F9=Refresh                                     F6=Roll
F12=Retrieve
```

Figure 43. ENABLE Command Dialog: Panel Before Any Action

The selected coupling facility has already been activated manually, therefore its status, as shown on the right side of the panel header, is DRAINED. The authorization type of the operator (ALL) is also displayed on the right side of the panel header. The main part of the panel is empty because no structures are allocated in CF02. The only action that is activated is ENABLE with F4. If you press F4 the following confirmation panel is displayed:

```

INGLX92E          SA OS/390 - Command Dialogs
Domain Id = IPSFO  ----- INGCF ENABLE -----
Operator Id = NETOP1                               Date = 02/20/01
                                                    Time = 11:06:20

Coupling Facility . : CF02
Sysplex . . . . . : KEY1PLEX

                E N A B L E Confirmation

The ENABLE process runs asynchronously on the next system in the Sysplex that
has access to the CFRM couple data set. All sender paths of all system in the
sysplex are set to ONLINE. Once started use the refresh PF key for getting
the current status of the process. The status NORMAL indicates a successful
completion.

Command ==>
                F2=End      F3=Return      F6=Ro11
                F10=Go      F11=Cancel   F12=Retrieve

```

Figure 44. Confirmation Panel for ENABLE

After pressing F10 on the confirmation panel, the command dialog changes as follows:

```

INGLX901          SA OS/390 - Command Dialogs          Line 1 of 3
Domain Id = IPSFO  ----- INGCF ENABLE -----          Date = 02/20/01
Operator Id = NETOP1                               Time = 11:06:39

Coupling Facility ==> CF02          Status . . . . . : NORMAL
Sysplex . . . . . ==> KEY1PLEX          Permission . . . . . : ALL
-----
Structure          Condition
-----
GRPYCSQ_ADMIN     Structure is currently allocated in CF01.
GRPYHSAQUEUE      Structure is currently allocated in CF01.
HSA_LOG           Structure is currently allocated in CF01.

Command ==>
F1=Help      F2=End      F3=Return      F6=Ro11
F9=Refresh   F10=Populate  F12=Retrieve

```

Figure 45. ENABLE Command Dialog: Panel After Enabling

The status has changed to NORMAL, and F10 is enabled for populating the coupling facility. This implies that the target coupling facility is defined in the active CFRM policy.

The structure list contains three entries with the condition 'Structure is currently allocated in CF01.'. These are the structures that are currently allocated in CF01, but have CF02 at the first position in their preference list.

Pressing F10 populates the coupling facility, and the refreshed panel looks as follows:

## INGCF ENABLE

```

INGLX901          SA OS/390 - Command Dialogs      Line 1 of 3
Domain Id = IPSFO ----- INGCF ENABLE -----      Date = 02/20/01
Operator Id = NETOP1                                Time = 11:17:35

Coupling Facility ==> CF02          Status . . . . . : NORMAL
Sysplex . . . . . ==> KEY1PLEX      Permission . . . . : ALL
-----
Structure          Condition
-----
GRPYCSQ_ADMIN      System-managed rebuild is supported.
GRPYHSAQUEUE       System-managed rebuild is supported.
HSA_LOG

Command ==>
F1=Help           F2=End           F3=Return          F6=Ro11
                  F9=Refresh          F12=Retrieve

```

Figure 46. ENABLE Command Dialog Panel: After Populating

The POPULATE action is no longer available because all structures whose preference list starts with CF02 are allocated in CF02.

## PATH

**Purpose:** The INGCF PATH function displays the sender paths, that is, the paths from the connected systems to the specified coupling facility.

**Restrictions:** The last sender path of each system can only be set to OFFLINE when no more structures are allocated.

### Example:

```

INGLX903          SA OS/390 - Command Dialogs      Line 1 of 14
Domain Id = IPSFN ----- INGCF PATH -----      Date = 06/20/01
Operator ID = HIR                                Time = 10:28:49

Coupling Facility ==> CF01          Allocated Structures: 37
Sysplex . . . . . ==> KEY1PLEX      Permission . . . . : ALL
-----
Cmds: F set OFFLINE / N set ONLINE

  System  CHPID  Physical          Logical  Type
  -----
_ KEY1    A5     ONLINE           ONLINE  CFS
_         A9     ONLINE           ONLINE  CFS
_ KEY2    A5     ONLINE           ONLINE  CFS
_         A9     ONLINE           ONLINE  CFS
_ KEY3    A5     ONLINE           ONLINE  CFS
_         A9     ONLINE           ONLINE  CFS
_ KEY4    05     ONLINE           ONLINE  CFS
_ KEY6    A5     ONLINE           ONLINE  CFS
_         A9     ONLINE           ONLINE  CFS

Command ==>
F1=Help           F2=End           F3=Return          F6=Ro11
                  F8=Forward       F9=Refresh          F12=Retrieve

```

Figure 47. PATH Dialog Panel

The following command codes are available:

**F** Sets the sender path OFFLINE.

**N** Sets the sender path ONLINE.

- If you have issued INGCf with the PATH parameter, the Coupling Facility field is an input field. To display the path list of another coupling facility specify the name of the coupling facility in this field and press ENTER.
- The Allocated Structures field shows the number of allocated structures.
- The Permission field shows your authorization level.
- The System column contains the names of the systems that are connected to the target coupling facility.
- The CHPID column shows the IDs of the sender channel paths.
- The Physical column shows the status of the sender channel paths.
- The Logical column shows the logical status of the paths to that coupling facility.
- The Type column shows the type of the sender channel paths.

## STRUCTURE

**Purpose:** The STRUCTURE function of the INGCf displays the allocated structures of a coupling facility. You can initiate a rebuild or deallocation of a selected structure if the conditions for these actions are satisfied.

**Example:**

```

INGLX904          SA OS/390 - Command Dialogs          Line 1   of 15
Domain ID   = IPSFM      ----- INGCf STRUCTURE -----      Date = 02/22/02
Operator ID = NETOP1                                Time = 16:09:04

Coupling Facility ==> CF01
Sysplex . . . . . ==> KEY1PLEX          Permission . . . . : ALL
Include condition ==> YES (Yes/No - Condition retrieval takes longer)
-----
Cmds: D display details / F force / P stop duplex / R rebuild / S start duplex

   Structure      P D Condition
-----
- DSNA_GBP0      U Duplex rebuild is active.
- DSNA_GBP32K    P U
- DSNA_LOCK1     S Duplex rebuild is active.
- DSNA_SCA       S System-managed rebuild is supported.
- ISGLOCK
- ISTGENERIC     System-managed rebuild is supported.
- IXCGRS
- IXCVLF
- M8SGEMHQ       System-managed rebuild is supported.
- M8SGMSGQ       System-managed rebuild is supported.
- M8SGMSGQ
- RRSARCH
- RRSDELAY
- RRSMAIN
- RRSREST       P *No alternate CF defined or available.

Command ==>
F1=Help      F2=End          F3=Return      F6=Roll
              F9=Refresh      F12=Retrieve

```

Figure 48. STRUCTURE Dialog Panel

The following action codes are available:

**D** Displays detail information about the structure.

## INGCF STRUCTURE

- \*F Forces the deallocation of the structure if it has one of the following conditions:
- No connection exists.
  - No alternate CF for structure with no active connections.
  - No alternate CF for structure with no connections.

When you try to force the deallocation of a structure that can be rebuilt, an error message is issued.

- \*P Stops duplexing of the selected structure.

- \*R Starts the rebuild of the selected structure. Depending on the PENDING status, the automation starts the rebuild with a different LOCATION parameter (PENDING uses the parameter LOCATION=NORMAL, otherwise LOCATION=OTHER). A rebuild with the parameter LOCATION=OTHER is only initiated for structures whose preference list contains more than one coupling facility.

There are two methods for rebuild, user-managed and system-managed rebuild. User-managed rebuild is supported for all release levels. System-managed rebuild is only available with systems that have OS/390 2.8 and above ; it must have been enabled by formatting the CFRM couple data sets with the specification

```
ITEM NAME(SMREBLD) NUMBER(1)
```

System-managed rebuild is only performed when the requirements for user-managed rebuild are not met. This applies, for example, to structures without active connectors.

INGCF STRUCTURE accepts a rebuild request for structures with the condition 'No active connection exists.', but *deallocates* them. See "No active connection exists" on page 78.

- \*S Starts duplexing of the selected structure.

There are two methods for duplexing, user-managed and system-managed duplexing. User-managed duplexing is supported for all release levels. System-managed duplexing is only available when all systems in the Parallel Sysplex have been upgraded to z/OS 1.2 or later with APAR OW41617, and appropriate APARs listed in the CFDUPLEX PSP bucket (for more information, see *System-Managed CF Structure Duplexing*, GM13-0103-03). System-managed duplexing must have been enabled by formatting the CFRM couple data sets with the specification

```
ITEM NAME(SMDUPLEX) NUMBER(1)
```

System-managed duplexing is only performed when the requirements for user-managed duplexing are not met. This applies, for example, to structures without active connectors.

Starting the duplex rebuild of a structure requires at least the policy entry allowing the duplex rebuild of the structure. If there is no entry the duplex rebuild is disabled. The other requirements depend on the type of the duplex rebuild. When all connectors to a structure allow user-managed duplex rebuild, this type takes precedence over system-managed duplex rebuild. However, user-managed rebuild also requires at least one active connector. Thus, when the operator starts the duplex rebuild for a structure allowing user-managed duplex rebuild as well as system-managed rebuild

but without having active connectors, XCF tries to initiate a system-managed duplex rebuild. System-managed duplex rebuild has the following requirements:

- System-managed rebuild must be supported by all connectors.
- The structure must be allocated in a coupling facility supporting system-managed duplexing and another coupling facility supporting system-managed duplexing must be defined in its preference list.
- The CFRM couple data set must support system-managed duplex rebuild and the structure must not have a policy change pending.
- The structure must be defined in the active CFRM policy when any connection state is not active.
- If you have specified INGCFL with the STR parameter, the **Coupling Facility** field is an input field. To display the structure list of another coupling facility, specify the name of the coupling facility in this field and press ENTER.
- The **Include Condition** field is an input field. By specifying Yes or No in this field you determine whether or not the conditions of the structures are displayed in the **Structure** column.
- The **Permission** field shows your authorization level. There are two possible values, ALL and DISPLAY. DISPLAY signifies that you can only use the display functions. ALL signifies that you can also rebuild and delete structures.
- You can specify an action code before every structure entry. The codes you can enter depend on your authorization level
- The **Structure** column shows the names of the structures.
- The letter P in the **P** column indicates that policy changes are pending for the structure.

A structure has policy changes pending when it was allocated at the time of a CFRM policy switch, and XES could not bring the switch into effect for that structure. One reason for a pending policy change is that the old and the new policy define the structure differently, for example, with different preference lists.

- The **Condition** column shows the status of the structures. You can switch on and off the display of the conditions through the **Include Condition** field.
- The D field indicates the type of duplexing being possible. The following values are possible:

- U      User-managed duplexing
- S      System-managed duplexing
- B      User-managed and system-managed duplexing

## INGCFL

### Purpose

The INGCFL routine supports line mode for INGCFL other than display capability. For further information refer to "INGCF" on page 73.

### Syntax

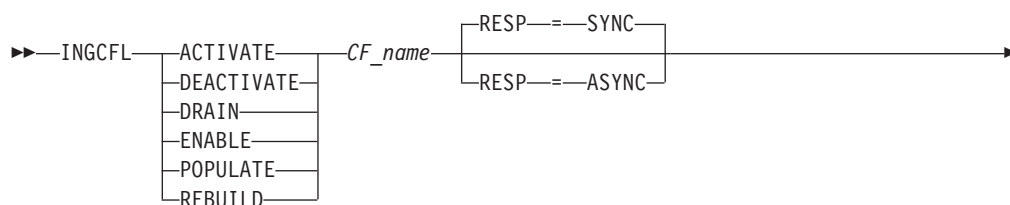

## INGCFL

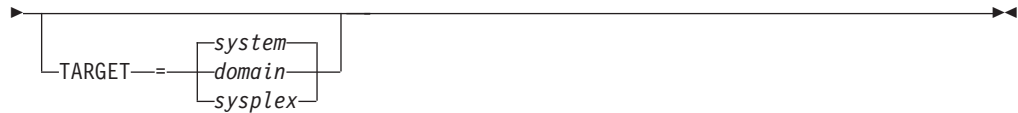

### Parameters

*cfname*

Is the name of the CF

#### ACTIVATE

Activates the coupling facility

#### DEACTIVATE

Deactivates the coupling facility after performing DRAIN

#### DRAIN

Sets the sender paths to OFFLINE after performing a REBUILD

#### ENABLE

Sets the sender paths to ONLINE after performing ACTIVATE

#### POPULATE

Starts the populate process of the coupling facility after performing ENABLE

#### REBUILD

Starts the rebuild process of the coupling facility

#### RESP

Specifies whether the final result is returned synchronously via return code or asynchronously via message (default: synchronous response)

#### TARGET

Specifies the system where the command is executed (default: local system)

**Note:** The real activation and deactivation of a coupling facility are unavailable when running on a z/OS image which runs under z/VM.

## INGCICS

### Purpose

The INGCICS command lets you:

- Issue any console-enabled CICS transaction
- Broadcast messages to all or selected CICS users
- Issue a list of defined transactions and view the output
- Display the output of CICS transactions in full-screen or pipeable line mode

### Syntax

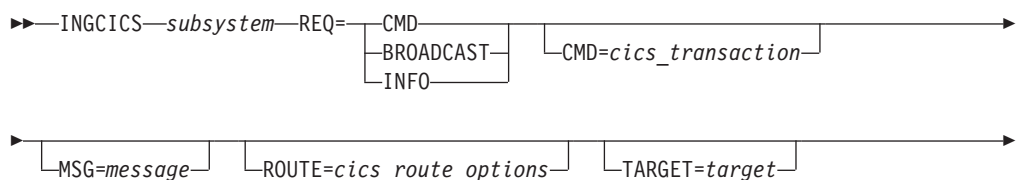



## Parameters

### resource

The resource specifies the name of the CICS subsystem to which the command will be issued. The format is subsystem[/APL[/system]], where the subsystem is the specific name of the desired CICS subsystem and system is the name of the system that the CICS is running on.

**Note:** You need not specify the fully qualified name of the resource. However, the command requires enough information to execute the request against a unique CICS subsystem. The command does not support issuing requests to multiple CICS subsystems at the same time.

### REQ

Specifies the request to be issued to the CICS subsystem. It can be one of the following:

**CMD** Issues a CICS transaction and displays the results

#### BROADCAST

Issues a CICS broadcast to all or selected users

**INFO** Issues a set of predefined commands and displays the results. The list of commands is obtained from the CICSINFO user message policy of the subsystem specified by the resource name.

### CMD

Specifies the CICS transaction and its parameters to be executed for a REQ=CMD type request. Enclose the command in quotes (single or double) if the command and parameters contain spaces.

### MSG

Specifies the message to be sent to all or selected CICS terminals/users for the REQ=BROADCAST request. Enclose the message in single or double quotes.

### ROUTE

Specifies the CICS routing information used to select which CICS terminals/users are to receive the message for a REQ=BROADCAST request. The contents of the ROUTE= parameter are the parameters to be supplied to the CMSG transaction to route messages to CICS terminals/users. See the CMSG transaction for the details of the parameters for that transaction.

### TARGET

For information on the TARGET parameter, refer to “Additional Parameters for System Operations Commands” on page 10.

### OUTMODE

For information on the OUTMODE parameter, refer to “Additional Parameters for System Operations Commands” on page 10.

## Restrictions and Limitations

To use the INGCICS command system operations must be initialized. CICS subsystems must be enabled for system console commands using the MVS MODIFY command.

## Usage

The INGCICS command operates sysplex-wide. For an overview refer to “Overview of Commands that Operate Sysplex-Wide” on page 9.

## Examples

If you type INGCICS REQ=CMD a panel similar to the following is displayed:

```

EVEKYCMD          SA OS/390 - Command Dialogs Line 1      of 28
Domain ID   = IPSFM   ----- INGCICS -----          Date = 03/05/02
Operator ID = KAT                               Time = 08:23:31

Resource      => EYUMAS1A/APL/KEY1                Format: name/type/system
System        =>                                     System name, domain ID or sysplex name
Request       => CMD                               CMD, BROADCAST or INFO
CICS Transaction => CEMT I TA
CICS Route    =>
CICS Message  =>
              =>

Tas(0000024) Tra(CONL)          Sus Tas Pri( 255 )
Sta(U ) Use(STCUSER ) Uow(B747C4105BD4E305)
Tas(0000026) Tra(COI0)          Sus Tas Pri( 255 )
Sta(U ) Use(STCUSER ) Uow(B747C413B3F7A908)
Tas(0000027) Tra(CONM)          Sus Tas Pri( 240 )
Sta(U ) Use(STCUSER ) Uow(B747C41430B48804)
Tas(0000028) Tra(CONM)          Sus Tas Pri( 240 )
Sta(U ) Use(STCUSER ) Uow(B747C41430C33084)
Tas(0000029) Tra(CONM)          Sus Tas Pri( 240 )
Sta(U ) Use(STCUSER ) Uow(B747C41430CFD804)
Tas(0000030) Tra(CONM)          Sus Tas Pri( 240 )
Sta(U ) Use(STCUSER ) Uow(B747C41430DB0684)
Tas(0000031) Tra(CONM)          Sus Tas Pri( 240 )
Sta(U ) Use(STCUSER ) Uow(B747C41430E8D844)
Tas(0000032) Tra(CONM)          Sus Tas Pri( 240 )
Sta(U ) Use(STCUSER ) Uow(B747C41430F56504)

Command ==>>
  PF1=Help      PF2=End      PF3=Return  PF4=DISPINFO      PF6=Ro11
                PF8=Forward  PF9=Refresh      PF12=Retrieve

```

Figure 49. INGCICS REQ=CMD Sample Panel

- The resource field shows the name of the CICS subsystem to be used for issuing the requests. The format is name/type[/system]. Wildcards are supported
- The System field shows the name of the system (system name, domain ID, or sysplex name) to which the command should be routed. Specifying this is only necessary if the resources are not part of the local sysplex.
- The Request field shows the request to be carried out. It can be CMD, BROADCAST or INFO.
- The CICS Transaction field shows the CICS transaction to be executed on the CICS subsystem specified by the resource field. The CICS Route field shows the routing parameters for the CMSG transaction when the request is BROADCAST.
- The CICS Message field shows the message to be sent to users/terminals for the BROADCAST request.
- The output from the CICS transaction will appear in the blank area after the CICS Message field.

If you specify INGCICS REQ=BROADCAST a panel similar to the following is displayed:

```

EVEKYCMD          SA OS/390 - Command Dialogs  Line 1    of 28
Domain ID   = IPSFM  ----- INGCICS -----      Date = 03/05/02
Operator ID = KAT                                     Time = 08:36:12

Resource      => EYUMAS1A/APL/KEY1                Format: name/type/system
System        =>                                     System name, domain ID or sysplex name
Request       => BROADCAST                          CMD, BROADCAST or INFO
CICS Transaction => CMSG R=&ROUTE',&MESSAGE',HEADING=YES,S
CICS Route    => ALL
CICS Message  => test1
              =>

Command ==>>
PF1=Help      PF2=End      PF3=Return    PF4=DISPINFO    PF6=Ro11
              PF9=Refresh  PF12=Retrieve

```

Figure 50. INGCICS REQ=BROADCAST Sample Panel

Do not change the &ROUTE and &MESSAGE parameters in the CICS Transaction field, they are resolved to the corresponding panel fields.

If you specify INGCICS REQ=INFO a panel similar to the following is displayed:

```

EVEKYCMD          SA OS/390 - Command Dialogs  Line 1    of 67
Domain ID   = IPSFM  ----- INGCICS -----      Date = 03/05/02
Operator ID = KAT                                     Time = 08:40:30

Resource      => EYUMAS1A/APL/KEY1                Format: name/type/system
System        =>                                     System name, domain ID or sysplex name
Request       => INFO                              CMD, BROADCAST or INFO
CICS Transaction =>
CICS Route    =>
CICS Message  =>
              =>

SYSTEM INFORMATION

Aging( 00500 )
Akp( 04000 )
Cdsasize(00786432)
Cicstslevel(010200)
Cmdprotect(Cmdprot)
Db2conn(SG12)
Dfltuser(STCUSER)
Dsalimit( 05242880 )
Dtrprogram( DFHDYP )
Dumping( Nosysdump )
Ecdsasize(0006291456)
Edsalimit( 0041943040 )
Erdsasize(0013631488)
Esdsasize(0000000000)

Command ==>>
PF1=Help      PF2=End      PF3=Return    PF4=DISPINFO    PF6=Ro11
              PF8=Forward  PF9=Refresh  PF12=Retrieve

```

Figure 51. INGCICS REQ=INFO Sample Panel

## INGEVENT

### Purpose

The INGEVENT command sets or resets a particular event of all affected resources in a sysplex, or for the specified resources.

# INGEVENT

## Syntax

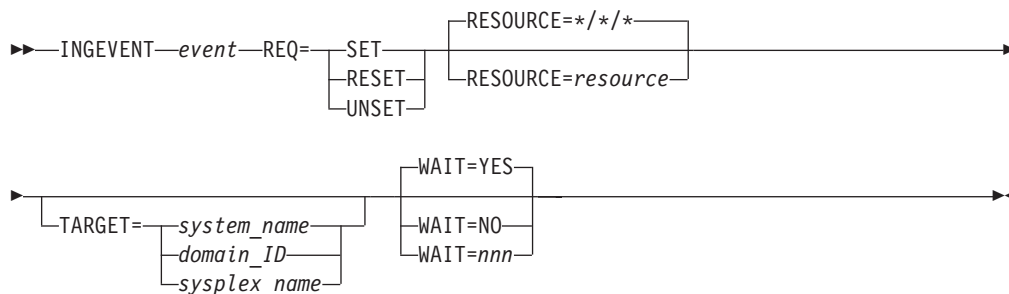

## Parameters

*event*

Specifies the name of the event

**REQ**

Specifies the request to be performed. It can have the following values:

**SET** Sets the event for all resources having the event defined

**RESET**

Resets the event for all resources having the event defined

**UNSET**

Unsets the event for all resources having the event defined

**RESOURCE**

Specifies the name of the resource where INGEVENT should be effective. It can be abbreviated to RES. The format is *name/type[/system]*

**TARGET**

For information on the TARGET parameter, refer to “Additional Parameters for System Operations Commands” on page 10.

**WAIT**

Specifies whether or not to wait until the request is complete. The default is YES.

*nnn* is the number of seconds to wait before giving up and reporting that a timeout has occurred. The maximum time interval is 999 seconds.

## Restrictions and Limitations

Wildcards are not supported.

## Usage

The INGEVENT command operates sysplex-wide. For an overview refer to “Overview of Commands that Operate Sysplex-Wide” on page 9.

Automation manager commands are not supported on downlevel systems. Note that whenever an automation manager command is issued to a target system that is running an SA OS/390 Version lower than 2.1, the NetView error message DSI002I will not contain the name of the command that was issued but the name of the associated slave command.

## Examples

To set an event for all resources that are linked to that event, type the following:

```
INGEVENT B000P100 REQ=SET
```

The command response is as follows:

```

IPUFA  AOF442I SET EVENT B000P100 DONE FOR RESOURCE */*/ ON AOCPLX. -
        FROM=AOCA
IPUFA  AOF099I FUNCTION COMPLETED
    
```

## INGFILT

### Purpose

The INGFILT command restricts the amount of information shown in the INGLIST display. Use INGFILT to set a default filter for the operator's logon. If an asterisk (\*) is specified, the filter is reset.

### Syntax



### filter\_criteria:

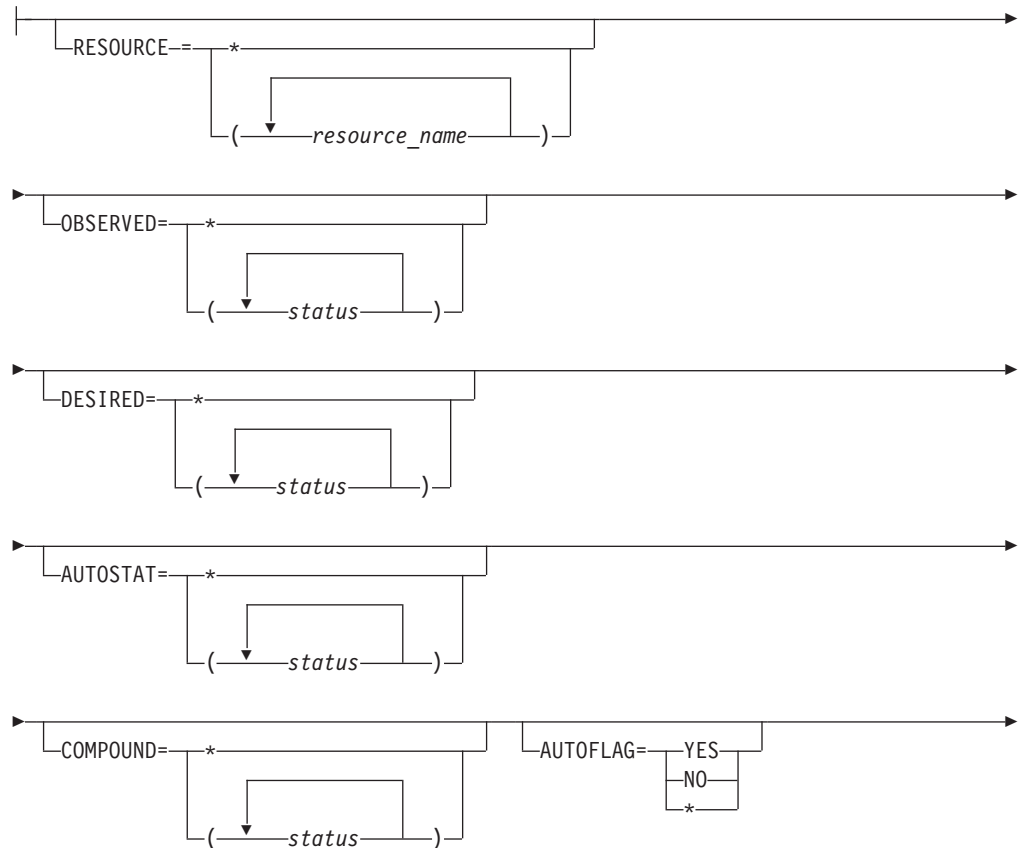

## INGFILT

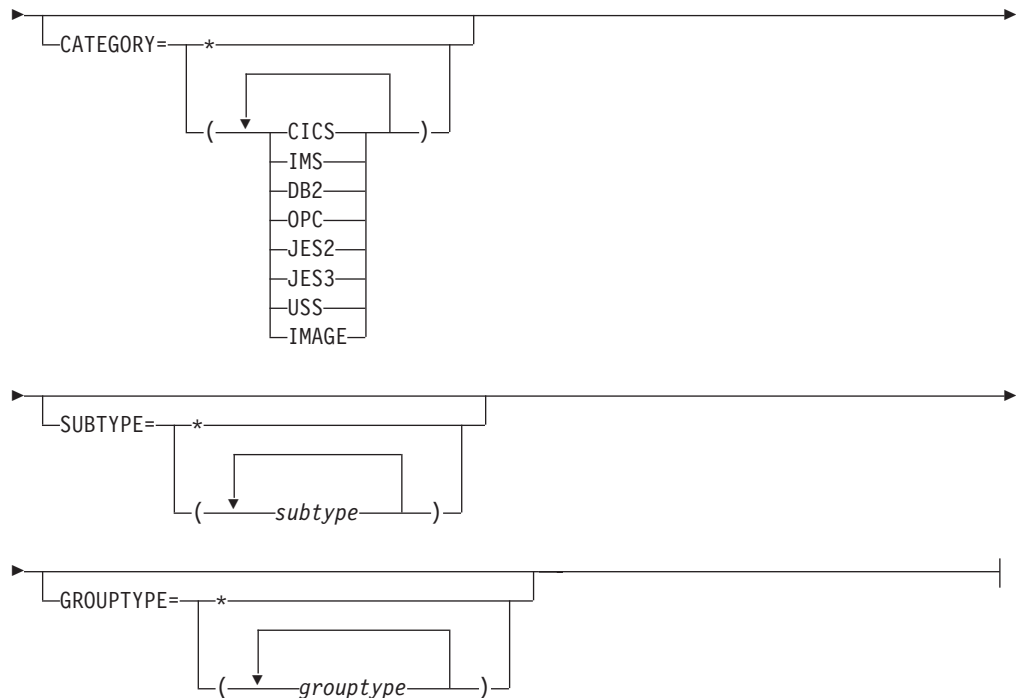

### Parameters

#### REQ

Specifies the type of the request. The type can be:

- SET** Sets new filter settings. This is the default. If no filter parameter is specified when the command is invoked, the appropriate value of the current filter settings is taken.
- GET** Returns the current filter settings. Any filter parameter that is specified when the command is invoked will be added to the current filter settings.

#### filter\_criteria

The filter criteria to be applied prior to displaying the data.

#### RESOURCE

Specifies the names of the resources to be displayed. The format is *name/type/system*. The resource names must be separated by a blank. Asterixes (\*) can be used as wildcard characters.

#### OBSERVED

Specifies the observed statuses to be displayed. The statuses must be separated by a blank. It can be abbreviated, for example to AV for available. Also, you can specify an asterisk (\*) to reset the current filter setting, for example, INGFILT OBSERVED=\*.

#### DESIRED

Specifies the desired statuses to be displayed. The statuses must be separated by a blank. It can be abbreviated, for example to AV for available. Also, you can specify an asterisk (\*) to reset the current filter setting, for example, INGFILT DESIRED=\*.

#### AUTOSTAT

Specifies the automation status to be displayed. The statuses must be

separated by a blank. It can be abbreviated, for example to ID for idle. Also, you can specify an asterisk (\*) to reset the current filter setting, for example, INGFILT AUTOSTAT=\*

**COMPOUND**

Specifies the compound status. The statuses must be separated by a blank. It can be abbreviated, for example to SA for satisfactory. Also, you can specify an asterisk (\*) to reset the current filter setting, for example, INGFILT COMPOUND=\*

**AUTOFLAG**

Specifies the automation flag to be displayed. It can be either **YES** or **NO** and can be abbreviated. Also, you can specify an asterisk (\*) to reset the current filter setting, for example, INGFILT AUTOFLAG=\*

**CATEGORY**

Specifies the category that the resource belongs to. More than one value can be specified.

**SUBTYPE**

Specifies the subtype of the resource.

**GROUPTYPE**

Specifies the type (nature) of the resource group. More than one value can be specified. Also, you can specify an asterisk (\*) to reset the current filter setting, for example, INGFILT GROUPTYPE=\*

**OUTMODE**

For information on the OUTMODE parameter, refer to “Additional Parameters for System Operations Commands” on page 10.

**Restrictions and Limitations**

None.

**Usage**

The INGFILT command can also be used when SA OS/390 is **not** initialized.

The INGFILT command lets you set filter options at operator logon from within the operator’s initial clist.

**Examples**

If you type `ingfilt` a panel similar to the following is displayed:

# INGGROUP

```

INGKYFLT          SA OS/390 - Command Dialogs
Domain ID   = IPUFA ----- INGFLT -----   Date = 07/24/00
Operator ID = NETOP1                               Time = 13:50:03

Specify or revise the filter criteria:

Resources...      format: name/type/system or *am*/**
*

Observed Status ==> *
Desired Status  ==> *
Automation Status ==> *
Compound Status ==> *

Automation flag ==>                               Yes or No

Resource category ==> *
Resource subtype ==> *

Command ==>
PF1=Help   PF2=End   PF3=Return   PF4=Clear   PF5=Reset   PF6=Roll
PF9=Save   PF12=Retrieve
  
```

Figure 52. INGFLT Command Dialog Panel

# INGGROUP

## Purpose

The INGGROUP command displays the members of a group and their settings. INGGROUP can also be used to:

- Move an application from one system to another by terminating the application and starting it on a system of your choice
- Activate or deactivate a group
- Adjust the availability target (server group only)

## Syntax

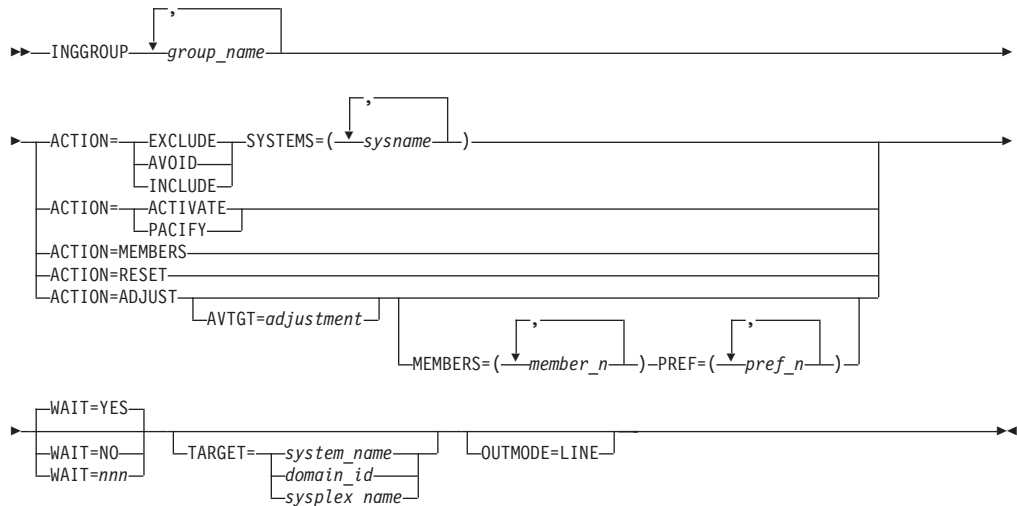

## Parameters

### group\_name

Is a list of application groups, possibly including wildcards that are to be the target of the command.

- For an ADJUST action specify only a single application group.
- For an AVOID/INCLUDE/EXCLUDE action, you may specify multiple application groups.
- For an ACTIVATE/PACIFY action, you may specify multiple application groups.
- For a MEMBERS action, you may specify only a single application group.

### ACTION

Indicates that one wants to remove movable members from a system (EXCLUDE), prohibit the manager from activating movable members on a system (AVOID) or that one wishes to undo either of the other two actions (INCLUDE).

### EXCLUDE

Removes resources immediately from the excluded systems. This acts to disruptively force resources from a system.

### AVOID

No new resources will be moved to the system and those that are there will be removed as scheduled service outages permit. This would be used to gradually (and non-disruptively) remove resources from a system in preparation for (mainly to reduce the disruption from ) an Exclude at a later point in time. Note, however, that if there is no other way to maintain/restore application availability that groups will choose to ignore avoidance policies.

### INCLUDE

The movement of resources to the system depends on the relative preferences of the resources on that system and on other systems. It is possible that the resources will not be moved to that system until the next scheduled service outage.

### ACTIVATE

Changes the behavior of a group to active. If used on an already active group there is no effect. When a group becomes active it will distribute votes to all of its non-passive members reflecting its nature and goals. Making a group active may cause some of its members to be stopped or started.

### PACIFY

Changes the behavior of a group to passive. If used on an already passive group there is no effect. When a group becomes passive, it withdraws all votes that it has propagated to its members. Making a group passive may cause some of its members to either start or stop, depending upon the votes that it had propagated.

### ADJUST

Indicates that one wants to temporarily adjust a group's policy.

### RESET

Causes to set the preference assigned to the members of the application group to its initial value. Applies only to MOVE and SERVER groups.

## SYSTEMS

Is the list of systems to be excluded or included. If no groups are specified, then all application groups with resources upon these systems will be affected.

This parameter must be specified for INCLUDE, AVOID and EXCLUDE actions.

## AVTGT

Specifies the availability target that is to be set for the group. The value, *n*, is a positive number. It specifies the number of group members that should be made available when the group has to be available.

You can also specify \*, which resets the AVTGT parameter to the value that is specified in the policy database.

This parameter may only be specified on an ADJUST action.

## MEMBERS

Specifies a list of group members, for which the preference value should be set. Wildcards may not be used.

This parameter may only be specified on an ADJUST action.

## PREF

Specifies a preference value that is to be used for each specified member. The number of values specified should be the same as the number of members specified. Each preference is an integer value that replaces the member's current preference value. You can also specify \*, which resets the PREF parameter to the value that is specified in the policy database.

Preference values are used to determine which members in the group are selected to make the group active.

This parameter may only be specified on an ADJUST action when a list of members has been specified.

Changes to preference values, as set by the PREF parameter, apply in the following manner:

- The preference value in the automation policy is not affected.
- An adjustment value is calculated, which when applied to the preference value in the automation policy, produces the "result" value.
- The "result" preference value is then used by automation when a preference value is required.
- The adjustment value, not the "result", is preserved when performing an automation manager HOT restart and an INGAMS REFRESH but is lost during WARM and COLD restarts.

## WAIT

Specifies whether or not to wait until the request is complete. The default is YES.

*nnn* is the number of seconds to wait before giving up and reporting that a timeout has occurred. The maximum time interval is 999 seconds.

## TARGET

For information on the TARGET parameter, refer to "Additional Parameters for System Operations Commands" on page 10.

## OUTMODE

For information on the OUTMODE parameter, refer to "Additional Parameters for System Operations Commands" on page 10.

## Restrictions and Limitations

None.

## Usage

The INGGROUP command operates sysplex-wide. For an overview refer to “Overview of Commands that Operate Sysplex-Wide” on page 9.

Automation manager commands are not supported on downlevel systems. Note that whenever an automation manager command is issued to a target system that is running an SA OS/390 Version lower than 2.1, the NetView error message DSI002I will not contain the name of the command that was issued but the name of the associated slave command.

Automation policy overrides, entered using the INGGROUP command, are preserved when performing an automation manager HOT restart and an INGAMS REFRESH but are lost during WARM and COLD restarts.

## Examples

To remove subsystems from the list of members that can be used, type the following:

```
INGGROUP group1, TSO/APG ACTION=EXCLUDE
```

## INGHC

### Purpose

This command serves two purposes:

1. Allows you to view the reports of the IBM Health Checker for z/OS and Sysplex (HealthChecker)
2. Allows you to request the HealthChecker to perform individual checks according to your filtering options

**Note:** If you want to override IBM’s best practice values with your own values, use the INGAMS REFRESH command.

### Types of reports

**About the reports:** The following rule applies for each check overridden in the user policy: If there is some error in your specification, the check is not performed at all, that is, the IBM values are not used either. To make the check active again, remove your override or fix it.

The HealthChecker reports reflect values at a point in time (snapshot). The report is comprised of a series of records in the System Logger. These records have the following components:

- Message text and explanation
- Recommendations of actions that can be taken to address an exception
- IBM suggestions
- Reasons for IBM’s suggestions

The HealthChecker generates two report formats:

- **Regular**

The regular format produces confirmation messages of those checks where the results meet either IBM’s or your override values. For selected checks, such as several related to consoles or UNIX System Services file systems, additional information about these resources is provided.

## INGHC

- **Exception**

The exception format provides status on checks that do not meet the criteria for the check.

To help distinguish a successful check from one encountering an exception, the record is explicitly marked in column 'E' as an I(BM) or U(ser) exception. In addition, the status of an exception is explicitly noted in the reports as:

\*Exception: IBM criteria not met\*

or

\*Exception: User criteria not met\*

Unless you take any of the actions given in "Types of actions", the HealthChecker performs regular checks at predefined time intervals. The time intervals are defined individually for each check as part of IBM's best practices and can be overridden. The checks are done based on IBM's best practices or your overrides.

**Types of actions:** You can request the HealthChecker to run selected checks or all checks at a point in time when you want it to.

**Recommendation:** You should iteratively run the HealthChecker function and take corrective action until you have no exceptions. You should either update the values used in your environment, override the IBM values, or suppress the IBM check. This is important so that on subsequent runs of the HealthChecker, you will only see exceptions that you should attend to. Otherwise, the reports may contain a mixture of messages that you regularly ignore and those that could reflect a new potential problem, making it more likely that you could miss a key exception message.

Minimally, you should run the HealthChecker when you reIPL. However, many values can change between IPLs. You may therefore want to consider the following:

- permanently having the HealthChecker perform the checks repeatedly based on their respective, defined time interval. If the time intervals that are predefined by IBM do not suit your needs, you can always override them for individual checks using the TIMEINT parameter.
- if you don't want to have the HealthChecker permanently active, you can activate it at regular intervals (for example, once a day) and then deactivate it.

## Syntax

### INGHC

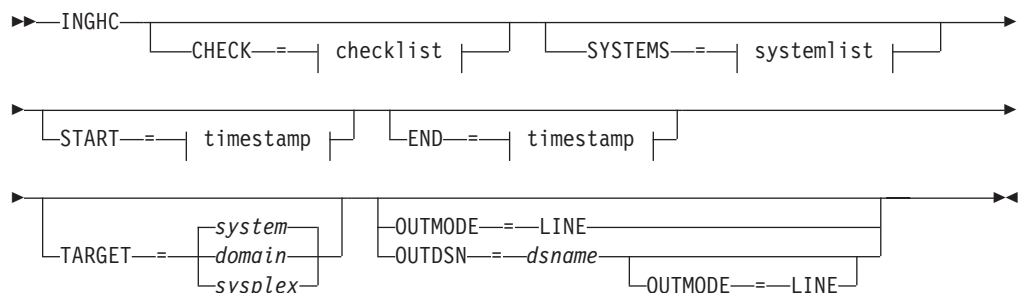

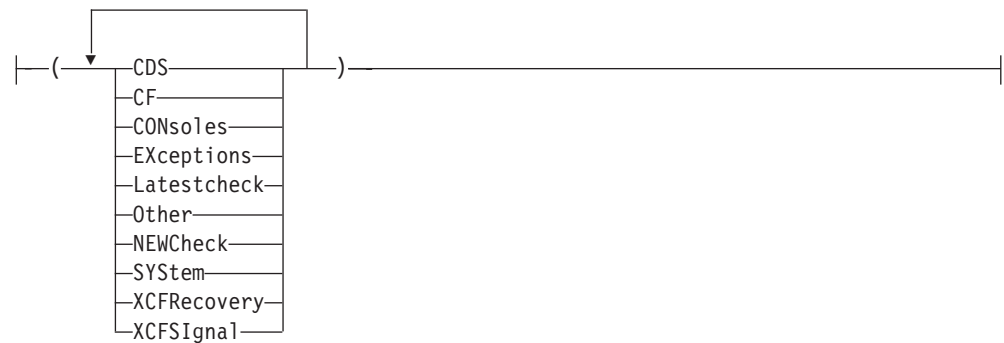
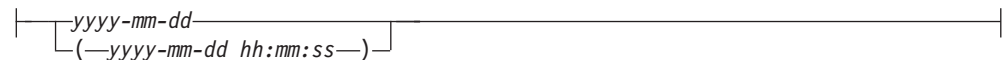
**checklist:****systemlist:****timestamp:****Parameters****CHECK**

Defines the filter options for the data to be displayed (default: the result of all checks):

<b>CDS</b>	Retrieves results relating to all of the various checks of all the couple datasets defined in the sysplex.
<b>CF</b>	Retrieves results relating to all of the various checks of all coupling facilities and structures in the sysplex.
<b>CONsoles</b>	Retrieves results relating to all of the various checks of all consoles defined in the sysplex.
<b>EXceptions</b>	Retrieves only results indicating an exception. This means the resource being checked does not meet either the IBM criteria or the user criteria.
<b>SYStem</b>	Retrieves results relating to system resource checks.
<b>Latestcheck</b>	Retrieves only the latest results of any kind of check.
<b>Other</b>	Retrieves results which do not belong to any of the filters.
<b>NEWCheck</b>	Requests the HealthChecker to immediately run checks as specified in the filter options and display the reports for those checks. The request is sent to all specified systems.
<b>XCFRecovery</b>	Retrieves results relating to checks of XCF recovery settings.
<b>XCFSignal</b>	Retrieves results relating to the XCF path checks.

## INGHC

If you specify more than one filter option, they must be enclosed by parentheses, for example, INGH C CHECK=(EX L). When the CHECK parameter is not provided, the DEFAULT will assume ALL checks.

### SYSTEMS

Specifies the list of systems for which the HealthChecker results should be retrieved, and where the specified actions are to be performed. If you specify more than one system name, they must be enclosed by parentheses, for example, INGH C SYSTEMS=(sys1 sys2). When the SYSTEM parameter is not provided, the DEFAULT will be all systems in the sysplex.

*sysname*

The name of the system.

### START

Is the start date and, optionally, start time for the display of the history data. The format is *yyyy-mm-dd [hh:mm:ss]*. If omitted, the history data from the last hour will be displayed, even if other parameters (such as check, systems) are specified. If you specify more than one value, they must be enclosed by parentheses, for example INGH C START=(2002-09-26 08:00:00).

**END** Is the end date and, optionally, end time for the display of the history data. The format is the same as for the START parameter.

*timestamp*

The date and time in the format *YYYY-MM-DD [hh:mm:ss]*.

### TARGET

For information on the TARGET parameter, refer to “Additional Parameters for System Operations Commands” on page 10.

### OUTMODE

For information on the OUTMODE parameter, refer to “Additional Parameters for System Operations Commands” on page 10.

### Examples

When you issue the INGH C command, the panel in Figure 53 on page 107 is displayed.

```

INGLX350          SA OS/390 - Command Dialogs          Line 1   of 82
Domain Id   = IPXNH          ----- INGHG -----          Date = 04/10/03
Operator Id = KHH          Sysplex = KEYAPLEX          Time = 09:53:16

Start time . ==> 2003-04-10 08:53:00   format: yyyy-mm-dd hh:mm:ss
End time ... ==> _____          Exceptions . ==> _____ Latest Check ==> _____
Consoles ... ==> X CDS ..... ==> X CF/STR ..... ==> X XCF signal. ==> X
XCF recovery ==> X System Res. ==> X Other ..... ==> X
System(s) .. ==> _____
-----
Cmds: + / - Expand/Collapse check results

Timestamp          System   E S Footprint
-----
2003-04-10 09:52:15 KEYA   I H USS_FILESYS_CONFIG
2003-04-10 09:52:15 KEYA   M SDUMP_AVAILABILITY
2003-04-10 09:52:15 KEYA   I M XCF_FAILURE_DETECTION_INTERVAL
2003-04-10 09:52:15 KEYA   I L XCF_CLEANUP_VALUE
2003-04-10 09:52:15 KEYA   L RSU_STORAGE_AVAILABILITY
2003-04-10 09:52:15 KEYA   I L REAL_STORAGE_AVAILABILITY

Command ==>
F1=Help      F2=End      F3=Return      F5=Coll. All  F6=Roll
F8=Forward   F9=Refresh  F10=NewCheck   F12=Retrieve

```

Figure 53. INGHG Panel

This panel displays the results of all Health Check requests. The fields in the non-scrollable area, in the top portion of the screen, allow filtering of Health Check requests as follows:

- Start time**      The date and time start filter in YYYY-MM-DD HH:MM:SS format converted to the local timezone. This defaults to the current time less one hour if not provided.
- End time**        The date and time end filter in YYYY-MM-DD HH:MM:SS format converted to the local timezone. This defaults to the current time if not provided.
- Exceptions**     The Exceptions filter returns *only* checks that show an exception that occurred between the Start and End times. This display can also be limited by using the other filters in this area.
- Latest Check**    The Latestcheck filter returns *only* the latest checks that have been performed. This display can also be limited by using the other filters in this area. You may have no output if the Latestcheck was performed at a time outside the Start and End times provided.
- System(s)**        The System(s) field enables you to restrict data to a specific system or group of systems in a sysplex.

**Note:** All systems are assumed if this field is left blank.

The following allows you to filter the checks you are interested in. You cannot filter individual checks, however, because the checks are grouped into categories. The following categories have been defined:

#### Consoles

The Consoles field returns all console-related results.

#### CDS

The CDS field returns all Couple-Data-Set-related results.

**CF/STR**

The CF/STR field returns all Coupling-Facility-Structure-related results.

**XCF signal.**

The XCF Signal field returns all XCF-Signalling-related results.

**XCF recovery**

The XCF Recovery field returns all XCF-RECOVERY-related results.

**System Res.**

The System Res. field returns all system-related check results.

**Other** The Other field returns all data not covered in the previous filters.

The lower portion of the panel is a scrollable area where the results of your requests are displayed. The output fields contain the data in the following format:

<b>Timestamp</b>	The Timestamp field indicates the actual date and time that the health check was performed.
<b>System</b>	The System field displays the system that the health check was performed on.
<b>E(xception)</b>	The Exception field indicates whether there is a deviation from the specified best practices (either IBM or User defined). An 'I' will indicate an IBM exception exists, a 'U' indicates that a User exception exists. A blank indicates that there are no exceptions.
<b>S(everity)</b>	The Severity field indicates the importance of the item. Its value is defined in the IBM best practices or user overrides. This field contains either L (Low), M (Medium), H (High).
<b>Footprint</b>	The Footprint contains the name of the check item. For the list of all valid names see the online help. To view an item or group of items in more detail, enter a '+' in the field to the left of the item(s) you wish to display and press Enter. To reset the display, enter a '-' in the field to the left of the item and press Enter to collapse it. The amount of detail displayed is limited by the size of one record in the system logger. If the output exceeds this limit, it is truncated, and the respective footprint is displayed in a different color.

Two PF keys are specific to this panel.

**Coll. All (PF5)** Collapses the detail description of all check results.

**NewCheck (PF10)**

Requests the HealthChecker to immediately run checks as specified in the filter options. The request is sent to all specified systems, the default is ALL. The report data is displayed, according to the filter options.

**Note:** Even if the input fields of the filter options show only an 'X' when selected they must be 2 characters long to support up to 26 footprint lines due to NetView restrictions.

**Note:** You should check that the systems listed in the New Check confirmation panels are those for which you want to refresh the user-defined best practices or perform a new check. This is because PF keys work such that they do not accept new values in input fields. Instead, they reset the input fields to the values last entered with the Enter key and then run the requested function. If Newcheck areis wanted for another system or for

some other filter in general (systems are a filter criterion) you first need to change those values and press Enter. The new values are then validated for correctness, and then the respective PF key can be executed correctly.

Pressing the PF10 key to request a NewCheck displays the Health Check confirmation screen, as shown in Figure 54.

```

INGLX35C          SA OS/390 - Command Dialogs
Domain ID = IPSFM  ----- INGHC -----      Date = 07/20/02
Operator ID = HIR          Sysplex = KEY1PLEX      Time = 17:13:51

                H E A L T H   C H E C K Confirmation

You have requested an additional check of the resources below on the indicated
systems. Press the GO function to perform the request.

Check(s) . .: CONSOLES      CDS          CF/STR      XCF SIGNAL.
              XCF RECOVERY  SYSTEM RES.  OTHER

System(s)  .: *ALL

Command ==>
              F2=End          F3=Return
                                F10=Go          F11=Cancel  F6=Roll
                                                F12=Retrieve

```

Figure 54. INGH C Check Confirmation Panel

This panel shows the selected check criteria to be performed and the systems involved. If you want to cancel the new check, press PF11, otherwise press PF10 to perform the request.

The output, when returned, will be sorted in descending Timestamp order, as shown in Figure 53 on page 107. You may sort the output by issuing the SORT command on the command line, followed by the sort direction (ascending or descending) and the column to sort. For example, to sort on Severity in descending order issue:

```
sort d 4
```

To search for text strings, issue the FIND, F, RFIND or RF commands. For example, to find the string *consoles*, enter the following:

```
f consoles n
```

**Note:** The FIND command can search *only* the text for those check results that have been expanded, even when the text is not visible on the action screen.

For more information about sorting output and searching for text strings, refer to the online help.

To view an item or group of items in more detail, enter a '+' in the field to the left of the item(s) you wish to display. To reset the display, enter a '-' in the field to the left of the item to 'collapse', or use PF5 to collapse all expanded items.

### Line mode output

If you issue the INGHHC command with OUTMODE=LINE, the output shows both the footprint data as well as the detail data, and will be similar to that shown in Figure 55.

```

NVSS V 1 R 4 IPXNG      Tivoli NetView  IPXNG XJIVENS  03/11/03 12:30:06
| IPXNG
Sysplex = KEYAPLEX

Timestamp              System    E S Footprint              11 Mar 2003 12:29:05
-----
2003-03-11 12:10:50 KEYB      HEALTH_CHECKER_ENDED
      z/OS Sysplex Health-Checker Version 01.02 5 Mar 2003 06:53:
      Ended for system KEYB in sysplex KEYAPLEX
      At 12:10:50 on 11 Mar 2003
2003-03-11 12:10:50 KEYB      I H CDS_DATASET_SEPARATION
The following PRIMARY couple datasets resides on Unique volumes:
  SYS1.KEYAPLEX.PXCFCDS: Primary SYSPLEX Couple dataset

This is consistent with the IBM recommendation that the primary
SYSPLEX Couple dataset, the primary CFRM Couple dataset, and the
primary LOGR Couple dataset, should be placed on different volumes.

CDS_DATASET_SEPARATION      *Exception: IBM Criteria not met*
The following PRIMARY couple datasets resides on the same volume
(KEYAXP):
=X= ***
    
```

Figure 55. INGHHC line mode output

## INGHIST

### Purpose

The INGHIST command shows history information about the work item processed by the automation manager. It also lets you display messages that the manager issues to the system logger.

### Syntax

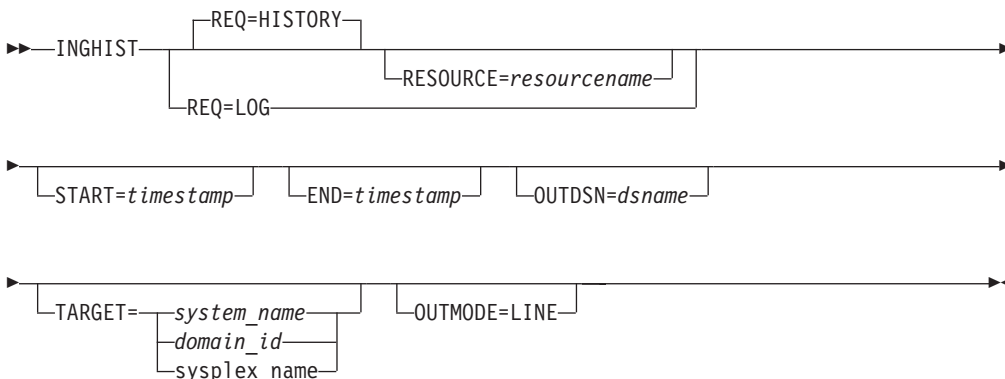

### Parameters

#### REQ

Specifies the request to be performed. It can have the following keywords:

**HISTORY**

Displays the workitem history. This is the default.

**LOG** Retrieves the messages written to the system logger by the automation manager.

**RESOURCE**

Specifies the name of the resource to be displayed. The format is *name/type[/system]*. The RESOURCE parameter can only be specified if REQ=HISTORY.

**START**

Is the start date, and optionally, end time for the display of the history data. The format is yyyy-mm-dd [hh:mm:ss]. If omitted, the history data from the last hour will be displayed, unless another limiting parameter (resource name) is specified. If you specify more than one value they must be enclosed by parentheses, or separated by a comma, for example, `inghist stdt000an1x start=(2000-03-10 08:00:00)` or `inghist stdt000an1x start=2000-03-10,08:00:00`.

**END**

Is the end date, and optionally, end time for the display of the history data. The format is yyyy-mm-dd [hh:mm:ss]. If you specify more than one value they must be enclosed by parentheses, or separated by a fullstop.

**OUTDSN**

For information on the OUTDSN parameter, refer to “Additional Parameters for System Operations Commands” on page 10.

**TARGET**

For information on the TARGET parameter, refer to “Additional Parameters for System Operations Commands” on page 10.

**OUTMODE**

For information on the OUTMODE parameter, refer to “Additional Parameters for System Operations Commands” on page 10.

**Restrictions and Limitations**

To use INGHIST system operations does not have to be initialized.

**Usage**

The INGHIST command operates sysplex-wide. For an overview refer to “Overview of Commands that Operate Sysplex-Wide” on page 9.

Automation manager commands are not supported on downlevel systems. Note that whenever an automation manager command is issued to a target system that is running an SA OS/390 Version lower than 2.1, the NetView error message DSI002I will not contain the name of the command that was issued but the name of the associated slave command.

Time-interval search criteria are entered in local time. However, because the history data is stored using GMT time stamps, it is necessary for INGHIST to convert the local-time search criteria to GMT before retrieving the data. This may make it necessary for the operator to make a manual adjustment to the time-interval search criteria after a daylight-saving-time change has been set. The local-time-to-GMT conversion calculation will be one hour different after a daylight-saving-time change. Data written after a daylight-saving-time change will be retrieved as expected but data written before will be offset by one hour.

**Examples**

If you type

```
inghist resource=stdt000an1x/ap1/aoc7
```

## INGHIST

a panel similar to the following is displayed:

```
INGKYHI0          SA OS/390 - Command Dialogs          Line 1   of 15
Domain ID   = IPUFM   ----- INGHIST -----          Date = 07/24/00
Operator ID = AFRANCK          Sysplex = AOC7PLEX          Time = 14:20:46

Start time ==>                               format: yyyy-mm-dd hh:mm:ss
End time   ==>                               Resource ==>  STDT000ANIX/APL/AOC7

Cmd: + Expand workitem (e)  - Collapse workitem (c)
Cmd Date   Time   Footprint
-----
2000-07-24 14:18:32 Termination processing for STDT000ANIX/APL/AOC7
                    completed
2000-07-24 14:18:30 Agent status for STDT000ANIX/APL/AOC7 = RESTART
2000-07-24 14:18:29 No PRESTART commands to issue
2000-07-24 14:18:29 Agent status for STDT000ANIX/APL/AOC7 = AUTODOWN
2000-07-24 14:18:27 Shutdown in progress
2000-07-24 14:18:25 Startup for STDT000ANIX/APL/AOC7 in progress
2000-07-24 14:18:24 Agent status for STDT000ANIX/APL/AOC7 = AUTOTERM
2000-07-24 14:18:23 Agent status for STDT000ANIX/APL/AOC7 = STARTED
2000-07-24 14:18:20 No SHUTINIT commands to issue

Command ==>
PF1=Help   PF2=End       PF3=Return   PF6=Ro11
```

Figure 56. INGHIST Command Dialog Panel

The FIND/RFIND subcommands are supported. Refer to “Deciding the Format of the Command Output (Full-Screen only)” on page 13 for information.

## INGIMS

### Purpose

The INGIMS command lets you:

- Issue any console-enabled IMS command
- Broadcast messages to all or selected IMS users
- Issue a list of defined transactions and view the output
- Display the output of IMS transactions in full-screen or pipeable line mode

### Syntax

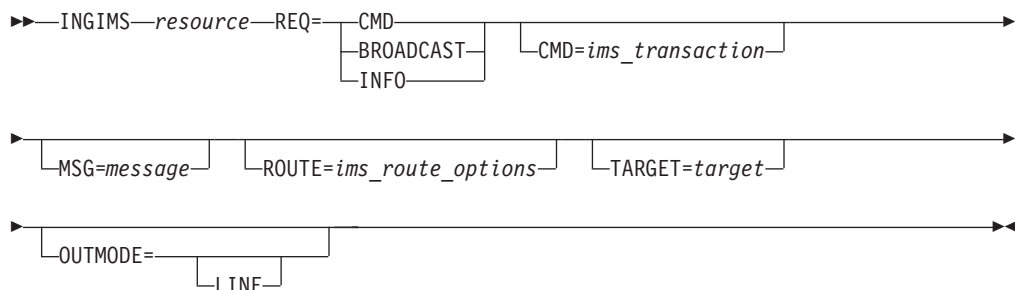

### Parameters

#### resource

The resource specifies the name of the IMS subsystem to which the command is issued. The format is subsystem[/APL[/system]], where the subsystem is the specific name of the desired IMS subsystem and system is the name of the system that the IMS is running on.

**Note:** You need not specify the fully qualified name of the resource. However, the command requires enough information to execute the request against a unique IMS subsystem. The command does not support issuing requests to multiple IMS subsystems at the same time.

**REQ**

Specifies the request to be issued to the IMS subsystem. It can be one of the following:

**CMD** Issues an IMS transaction and displays the results

**BROADCAST**

Issues an IMS broadcast to all or selected users

**INFO** Issues a set of predefined commands and displays the results. The list of commands is obtained from the IMSINFO user message policy of the subsystem specified by the resource name.

**CMD**

Specifies the IMS transaction and its parameters to be executed for a REQ=CMD type request. Enclose the command in single or double quotes if the command and parameters contain spaces.

**MSG**

Specifies the message to be sent to all or selected IMS terminals/users for the REQ=BROADCAST request. Enclose the message in single or double quotes.

**ROUTE**

Specifies the IMS routing information used to select which IMS terminals/users are to receive the message for a REQ=BROADCAST request. The contents of the ROUTE= parameter are the parameters to be supplied to the CMSG transaction to route messages to IMS terminals/users. See the CMSG transaction for the details of the parameters for that transaction.

**TARGET**

For information on the TARGET parameter, refer to "Additional Parameters for System Operations Commands" on page 10.

**OUTMODE**

For information on the OUTMODE parameter, refer to "Additional Parameters for System Operations Commands" on page 10.

**Restrictions and Limitations**

To use the INGIMS command system operations must be initialized. IMS subsystems must be enabled for system console commands using the MVS MODIFY command.

**Usage**

The INGIMS command operates sysplex-wide. For an overview refer to "Overview of Commands that Operate Sysplex-Wide" on page 9.

**Examples**

If you type INGIMS a panel similar to the following is displayed:

```

EVEKYCMD          SA OS/390 - Command Dialogs   Line
Domain ID = IPSFM  -----  INGIMS  -----  Date = 04/11/02
Operator ID = NETOP1                               Time = 18:11:35

Resource          =>                               Format: name/type/system
System            =>                               System name, domain ID or sysplex name
Request           => CMD                           CMD, BROADCAST or INFO
IMS Command       =>
IMS Route         =>
IMS Message       =>
                  =>

Command ==>
PF1=Help   PF2=End   PF3=Return  PF4=DISPINFO   PF6=Roll
            PF9=Refresh                                PF12=Retrieve
    
```

Figure 57. INGIMS Command Dialog Panel

- The resource field shows the name of the IMS subsystem to be used for issuing the requests. The format is name/type[/system]. Wildcards are supported
- The System field shows the name of the system (system name, domain ID, or sysplex name) to which the command should be routed. Specifying this is only necessary if the resources do not reside on the local sysplex.
- The Request field shows the request to be carried out. It can be CMD, BROADCAST, or INFO.
- The IMS Command field shows the IMS transaction to be executed on the IMS subsystem specified by the resource field.
- The IMS Route field shows the routing parameters for the /BRO command when the request is BROADCAST.
- The IMS Message field shows the message to be sent to users/terminals for the BROADCAST request.
- The output from the IMS transaction will appear in the blank area after the IMS Message field.

If you specify INGIMS \* REQ=BROADCAST a panel similar to the following is displayed:

```

EVEKYCMD          SA OS/390 - Command Dialogs Line
Domain ID = IPSFP ----- INGIMS ----- Date = 06/27/02
Operator ID = NETOP1                               Time = 18:25:56

Resource          =>                               Format: name/type/system
System            =>                               System name, domain ID or sysplex name
Request           => INFO                           CMD, BROADCAST or INFO
IMS Command       =>
IMS Route         =>
IMS Message       =>
                  =>

Command ==>>
PF1=Help         PF2=End           PF3=Return    PF4=DISPINFO    PF6=Roll
                  PF9=Refresh      PF12=Retrieve
    
```

Figure 58. INGIMS REQ=BROADCAST Sample Panel

## INGINFO

### Purpose

INGINFO displays details about a particular group or resource from the automation manager point of view. The following information can be displayed:

- Resource statuses
- Dependency statuses
- Resource settings
- Relationships existing to other resources
- Requests and votes pending for the resource
- History information collected for the resource

### Syntax

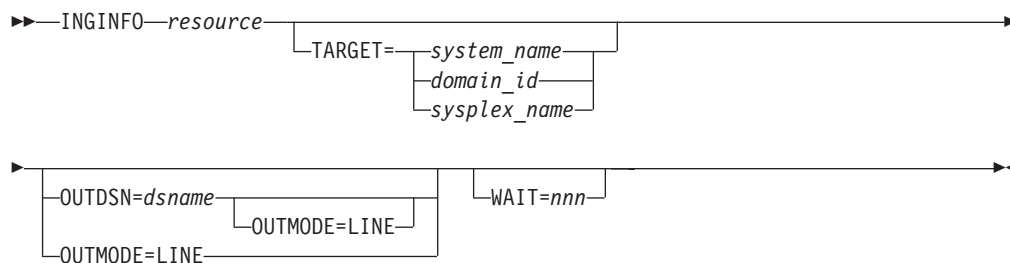

### Parameters

*resource*

Specifies the name of the resource to be displayed. The format is *name/type[/system]*.

### TARGET

For information on the TARGET parameter, refer to “Additional Parameters for System Operations Commands” on page 10.

## INGINFO

### OUTMODE

For information on the OUTMODE parameter, refer to “Additional Parameters for System Operations Commands” on page 10.

### OUTDSN

For information on the OUTDSN parameter, refer to “Additional Parameters for System Operations Commands” on page 10.

### WAIT

Specifies the number of seconds to wait before reporting that a timeout occurred if the automation manager does not provide the requested data. The maximum time interval is 999 seconds.

If omitted, the time interval is 30 seconds.

## Restrictions and Limitations

None.

## Usage

The INGINFO command operates sysplex-wide. For an overview refer to “Overview of Commands that Operate Sysplex-Wide” on page 9.

Automation manager commands are not supported on downlevel systems. Note that whenever an automation manager command is issued to a target system that is running an SA OS/390 Version lower than 2.1, the NetView error message DSI002I will not contain the name of the command that was issued but the name of the associated slave command.

## Examples

If you type inginfo TPXA/APL/KEY3 a panel similar to the following is displayed:

```
INGKYINO          SA OS/390 - Command Dialogs          Line 1    of 706
Domain ID   = IPSNO   ----- INGINFO -----          Date = 03/10/00
Operator ID = NETOP1          Sysplex = KEY1PLEX          Time = 19:18:05

Resource ==> TPXA/APL/KEY3          format: name/type/system
System      ==>          System name, domain ID or sysplex name

Resource      : TPXA/APL/KEY3
Description   : Simulated subsystem

Status...    :
Observed Status : AVAILABLE
Desired Status  : AVAILABLE
Automation Status : IDLE
Startable Status : YES
Compound Status  : SATISFACTORY

Dependencies :
PreStart       : Satisfied
Start          : Satisfied

Command ==>
PF1=Help      PF2=End      PF3=Return   PF4=DISPINFO          PF6=Roll
PF8=Forward   PF9=Refresh          PF12=Retrieve
```

Figure 59. INGINFO Command Dialog Panel

Press PF4 to toggle to the automation agent command DISPINFO (resource type APL).

# INGLIST

## Purpose

The INGLIST command displays details about one or more resources.

## Syntax

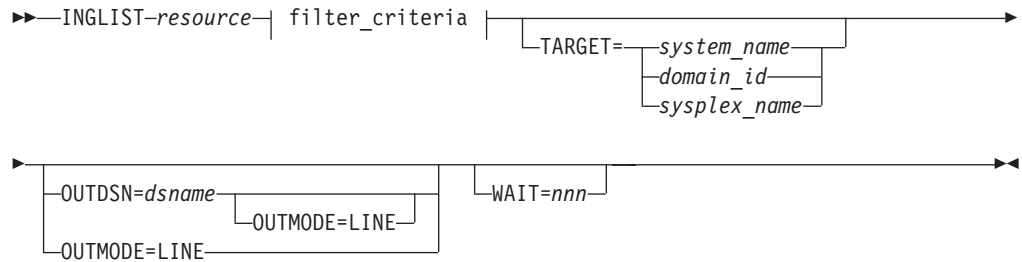

### filter\_criteria:

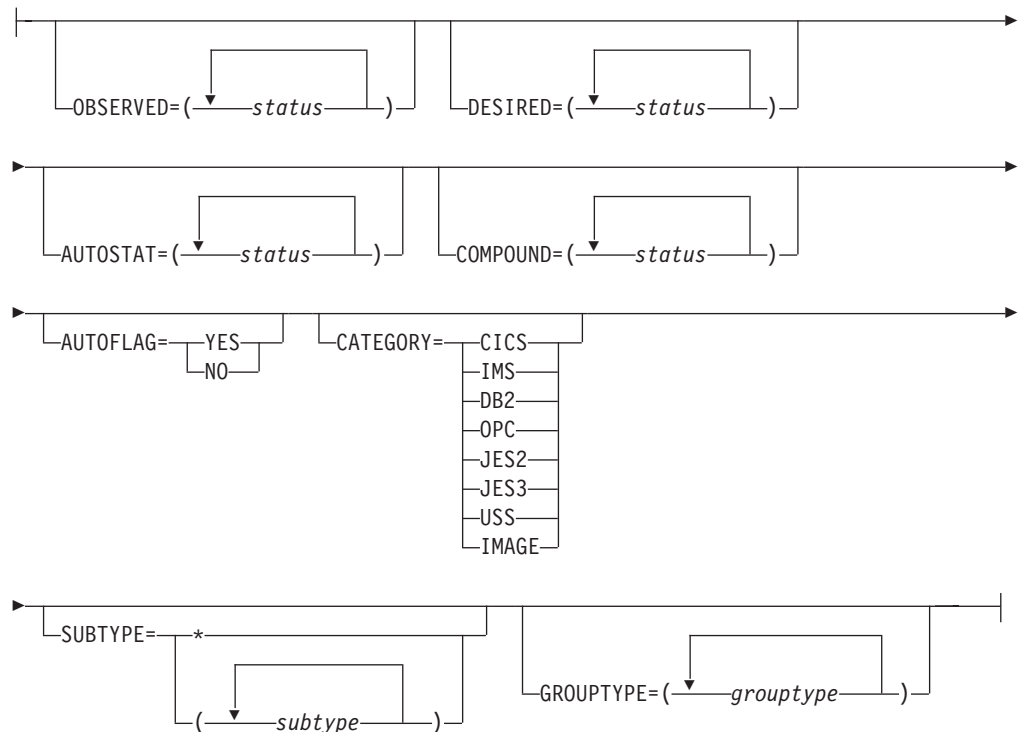

## Parameters

### *resource*

Specifies the name of the resource(s) to be displayed. The format is *name/type[/system]*. It can be a list of names. The resource names must be separated by a blank. Asterixes (\*) can be used as wildcard characters.

### *filter\_criteria*

The filter criteria to be applied prior to displaying the data. See also the related INGFILE command "INGFILE" on page 97 for further information. The following values can occur:

## INGLIST

### **OBSERVED**

Specifies the observed statuses to be displayed. The statuses must be separated by a blank. It can be abbreviated, for example to AV for available.

### **DESIRED**

Specifies the desired statuses to be displayed. The statuses must be separated by a blank. It can be abbreviated, for example to AV for available.

### **AUTOSTAT**

Specifies the automation status to be displayed. The statuses must be separated by a blank. It can be abbreviated, for example to ID for idle.

### **COMPOUND**

Specifies the compound status. The statuses must be separated by a blank. It can be abbreviated, for example to SA for satisfactory.

### **AUTOFLAG**

Specifies the automation flag to be displayed. It can be either **YES** or **NO** and can be abbreviated.

### **CATEGORY**

Specifies the category that the resource belongs to. More than one value can be specified.

### **SUBTYPE**

Specifies the subtype of the resource.

### **GROUPTYPE**

Specifies the type (nature) of the resource group. More than one value can be specified.

For further information about statuses, refer to *System Automation for OS/390 User's Guide*.

### **TARGET**

For information on the TARGET parameter, refer to "Additional Parameters for System Operations Commands" on page 10.

### **OUTMODE**

For information on the OUTMODE parameter, refer to "Additional Parameters for System Operations Commands" on page 10.

### **OUTDSN**

For information on the OUTDSN parameter, refer to "Additional Parameters for System Operations Commands" on page 10. Note, however, that for the INGLIST command the minimum record length of the output data set is 256 bytes.

### **WAIT**

Specifies the number of seconds to wait before reporting that a timeout occurred if the automation manager does not provide the requested data. The maximum time interval is 999 seconds.

If omitted, the time interval is 30 seconds.

### **Restrictions and Limitations**

None.

## Usage

The INGLIST command operates sysplex-wide. For an overview refer to “Overview of Commands that Operate Sysplex-Wide” on page 9.

Automation manager commands are not supported on downlevel systems. Note that whenever an automation manager command is issued to a target system that is running an SA OS/390 Version lower than 2.1, the NetView error message DSI002I will not contain the name of the command that was issued but the name of the associated slave command.

## Examples

If you type inglist, you see information on all automated resources:

```

INGKYST0          SA OS/390 - Command Dialogs          Line 1 of 383
Domain ID = IPSNO ----- INGLIST -----          Date = 03/02/00
Operator ID = NETOP1          Sysplex = KEY1PLEX          Time = 16:13:19
CMD: A Update   B Start   C Stop   D INGRELS   E INGVOTE   F INGINFO
      G Members   H DISPTRG   I INGSCHED   J INGGROUP   / scroll
CMD Name        Type System   Compound     Desired     Observed     Nature
-----
ALLOCAS        APL KEY1     INHIBITED    AVAILABLE    UNKNOWN
ALLOCAS        APL KEY2     INHIBITED    AVAILABLE    UNKNOWN
ALLOCAS        APL KEY3     SATISFACTORY AVAILABLE    AVAILABLE
ALLOCAS        APL KEY4     INHIBITED    AVAILABLE    UNKNOWN
AMCP           APL KEY1     INHIBITED    AVAILABLE    UNKNOWN
AMCP           APL KEY2     INHIBITED    AVAILABLE    UNKNOWN
AMCP           APL KEY3     PROBLEM      AVAILABLE    HARDDOWN
AMCP           APL KEY4     INHIBITED    AVAILABLE    UNKNOWN
ANTMAIN        APL KEY1     INHIBITED    AVAILABLE    UNKNOWN
ANTMAIN        APL KEY2     INHIBITED    AVAILABLE    UNKNOWN
ANTMAIN        APL KEY3     SATISFACTORY AVAILABLE    AVAILABLE
ANTMAIN        APL KEY4     INHIBITED    AVAILABLE    UNKNOWN
AOCAPPL        APL KEY1     INHIBITED    AVAILABLE    UNKNOWN

Command ==>
PF1=Help   PF2=End   PF3=Return   PF4=DISPSTAT   PF5=Filters   PF6=Roll
           PF8=Forward   PF9=Refresh   PF10=Previous   PF11=Next     PF12=Retrieve

```

Figure 60. INGLIST Command Dialog Panel 1

Press PF10 and PF11 to display more information.

PF4 lets you toggle to the DISPSTAT command dialog, PF5 calls the INGFILT command dialog.

- The CMD field lets you specify command codes. To use one of the command codes shown, type the appropriate letter next to the resource name and press Enter. The following command codes are available:
  - A** Resets the status of the resource or application group (observed status, automation status). Sets or resets attributes assigned to the resource.
  - B** Start. Calls the INGREQ command dialog to make the resource available. Refer to “INGREQ” on page 156 for further information.
  - C** Stop. Calls the INGREQ command dialog to make the resource unavailable. Refer to “INGREQ” on page 156 for further information.
  - D** Displays the dependency information and its evaluation for the resource
  - E** Invokes the INGVOTE command, showing all requests currently present for the resource. Allows the operator to cancel a request.
  - F** Shows details about the resource by invoking the INGINFO command
  - G** Shows all members for the selected application group in a new window
  - H** Invokes the DISPTRG command to show the trigger definitions for the selected resource

## INGLIST

**I** Invokes the INGSCHED command showing the resource overrides that exist for the selected resource

**J** Invokes the INGGROUP command

- The Name field shows the name of the resource.
- The Type field shows the type of the resource.
- The System field shows where the resource is defined.
- The Compound field shows the compound status of the resource. This is a summary of all statuses of the resource and provides a single value to check the status of a resource.
- The Desired field shows the status that the automation manager is trying to move the resource to. It can either be available or unavailable.
- The Nature field applies to group resources only and defines the type of the group. It can have the following values:

### BASIC

Indicates that the group contains a number of different resources, all of which perform different roles to constitute a complete application.

### MOVE

Indicates that the group contains alternate instances of the same resource

### SERVER

Indicates that the group contains a number of readily interchangeable resources. The group has a target that tells the automation manager how many of them should be made available for the group to be available.

The SORT/FIND/RFIND subcommands are supported. Refer to “Deciding the Format of the Command Output (Full-Screen only)” on page 13 for information.

## Setting the Status/Attribute of a Resource or Application Group

When you enter command code A for a resource, a panel similar to the following is displayed:

```
INGKYST1          SA OS/390 - Command Dialogs
Domain ID  = IPSFP  ----- INGLIST -----   Date = 06/27/02
Operator ID = NETOP1      Sysplex = KEY1PLEX      Time = 18:28:35

Resource . . : AM/APL/KEY4
Description. : Primary Automation Manager

Specify the action to be performed:

Action ==>      1. Set START Type                current setting
                2. Set STOP Type
                3. Set Automation Flag NO        YES
                4. Set Hold Flag YES            NO
                5. Set Group failed flag        (Yes or No)
                6. Set Observed Status          AVAILABLE
                7. Set Automation Status       IDLE
                8. Set Agent Status            UP

Command ==>
PF1=Help      PF2=End      PF3=Return      PF6=Ro11
```

Figure 61. INGLIST Command Dialog Panel 2

- The Resource field shows the name of the resource.
- The Description field shows descriptive information about the resource.
- The Action field shows the action to be performed.

## INGLKUP

### Purpose

The INGLKUP command lets you display all jobs that are not controlled by SA OS/390. You can either stop, cancel or force those jobs with the corresponding MVS command. With the INGLKUP command you can list all active jobs, started tasks (STCs) and APPC/MVS transaction programs. With an exclude list, you can tailor the list displayed.

### Syntax

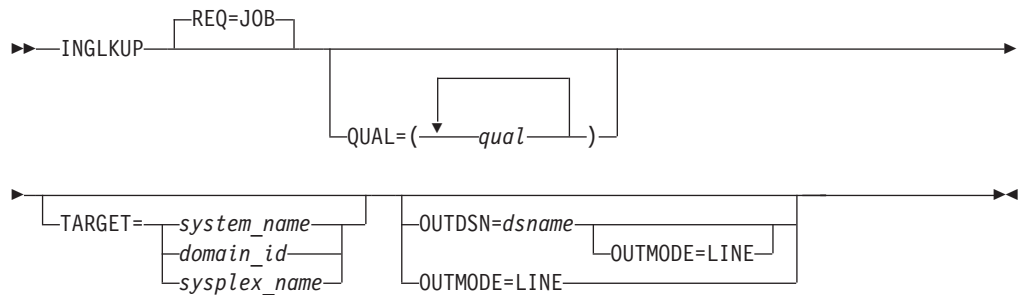

The INGLKUP command can also be used to obtain information about a particular resource if you want to perform debugging. The format is then as follows:

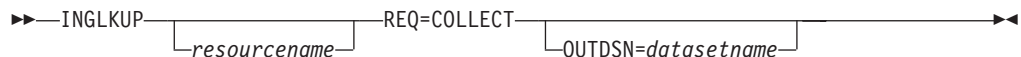

### Parameters

#### REQ

Specifies the type of request to be performed. The only request supported is JOB. It causes to display all jobs, started tasks and APPC/MVS transaction programs that are not controlled by SA OS/390. Note that the term JOB includes batch jobs, started tasks and APPC/MVS programs.

#### QUAL

Specifies the active jobs to be displayed. It can be JOB, STC or APPC. The default is ALL. You can specify more than one qualifier. If more than one qualifier is specified, the qualifiers must be enclosed in parentheses.

#### REQ

Specifies the action to be performed. Only COLLECT is supported.

#### OUTMODE

For information on the OUTMODE parameter, refer to “Additional Parameters for System Operations Commands” on page 10.

#### TARGET

For information on the TARGET parameter, refer to “Additional Parameters for System Operations Commands” on page 10.

## INGLKUP

### OUTDSN

Specifies the name of the data set that is to contain the output of the command. You can specify a sequential data set or a member of a partitioned data set. The record length must be at least 80 bytes if a resource is specified or 256 bytes if no resource is specified. The data set must already exist. If no output data set name is specified the output is written to the netlog. The OUTDSN parameter forces OUTMODE=LINE.

### Restrictions and Limitations

None.

### Usage

The exclude list allows the automation administrator to reduce the list of active jobs being shown. The exclude list is defined with User Entry type pairs. The format of the UET is as follows:

```
INGLKUP  EXCLUDE,  
        JOB=HUGO  
        JOB=abc*
```

The keyword can be:

#### REQUEST=JOB

Refers to batch jobs. The keyword value specifies the job name. Wildcard is supported. Note that if the program can run as started task and as batch job but should be excluded from the display, then two entries must be specified, one for JOB and one for STC.

#### REQUEST=COLLECT

If you issue INGLKUP without specifying a resource name, the following information is displayed:

```
INGLIST  
DISPSTAT
```

If you issue INGLKUP specifying a resource name, the following information is displayed:

```
INGINFO  
INGRELS  
INGSCHED  
DISPINFO  
DISPTRG
```

The following information is displayed per default:

```
INGVOTE  
INGHIST (history data and messages from the automation manager)
```

### Examples

If you specify `inglkup` and cancel a job with command code C a panel similar to the following is displayed:

```

INGKYL00          SA OS/390 - Command Dialogs          Line 1 of 24
Domain ID = IPSFP ----- INGLKUP -----          Date = 06/28/02
Operator ID = NETOP1          System = KEY4          Time = 14:36:17

Cmd: C cancel job          F force job          P stop job

Cmd Job          Step          Procedure Type ASID
-----
AMST             AMST             AMPROC        SO
AMST2            AMST2            AMPROC        SO
APPC             APPC             APPC          S
ASCH             ASCH             ASCH          S
BTSO             BTSO             AAASSEM       S          ** CANCELLED **
BZOEWTO1        BZOEWTO1        J
CU12             STEP1            CU12          AO          0049
CU12             STEP1            CU12          AO          005A
CU129            STEP1            CU12          AO
FTPD1            STEP1            FTPOE         AO
FTPOE1           STEP1            FTPOE         AO

Command ==>
PF1=Help          PF2=End          PF3=Return          PF6=Ro11
                   PF8=Forward       PF9=Refresh         PF12=Retrieve
    
```

Figure 62. INGLKUP Command Dialog Panel

## INGNTFY

### Purpose

INGNTFY adds, changes, or deletes notification operator settings.

### Syntax

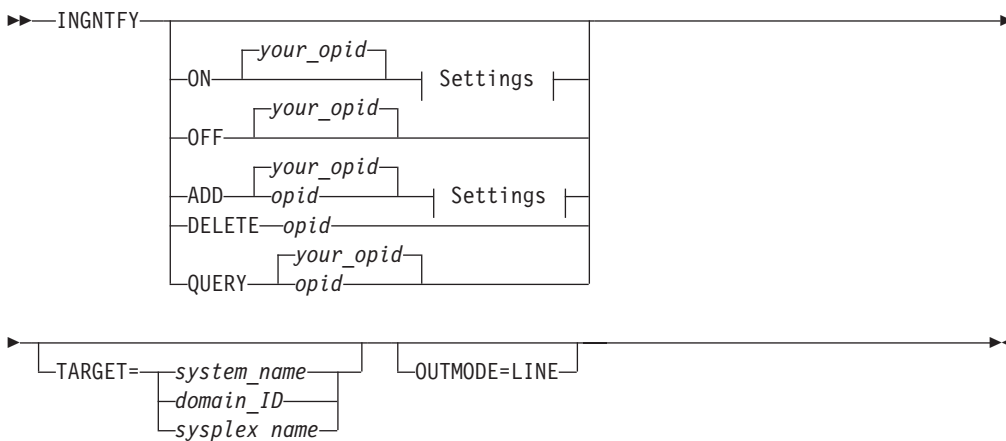

### Settings:

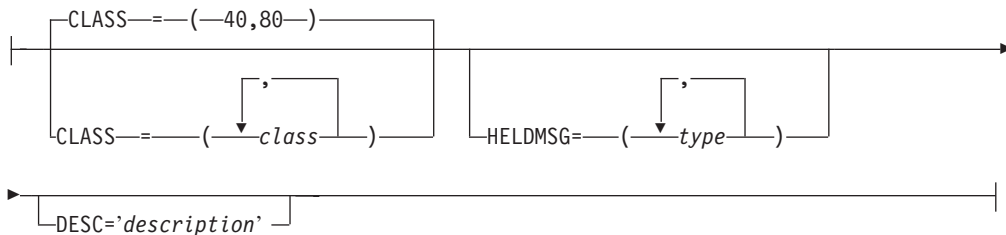

## Parameters

### ON

Allows the operator who issues the command to receive notifications.

### OFF

Turns off notifications for the operator who issues the command.

### ADD

Adds the operator specified in *opid* to the list of notification operators, or changes the definition of the existing operator specified in *opid*.

**Note:** Use of the ADD function to change the definition of an existing operator completely deletes the old definition. It is necessary to respecify all message classes and held message types that you wish this operator to retain. This allows you to remove unwanted message classes and held message types from an existing operator.

### DELETE

Removes the operator specified in *opid* from the list of notification operators.

### QUERY

Displays information about the operator specified in *opid*.

#### *opid*

The ID of the operator to add, change, delete, or query.

#### *your\_opid*

The ID of the operator issuing the command.

### CLASS

The classes of messages the operator is to receive. Refer to *System Automation for OS/390 Messages and Codes* for information on which classes are valid. Up to ten comma-delimited classes, enclosed in parentheses, can be defined for an operator. The default classes are 40 + 80, unless defined otherwise in the automation control file.

### DESC

An optional description of the operator. If the description contains blanks, commas, or other punctuation characters it must be enclosed in single quotation marks.

### HELDMSG

The type or types of messages to hold on the operator's screen. If more than one type is specified, the types should be separated by commas and enclosed in parentheses. The types are:

#### Type    Meaning

A	Immediate Action
D	Immediate Decision
E	Eventual Action
I	Information
W	System Wait

### TARGET

For information on the TARGET parameter, refer to "Additional Parameters for System Operations Commands" on page 10.

**OUTMODE**

For information on the OUTMODE parameter, refer to “Additional Parameters for System Operations Commands” on page 10.

For further details of message types and message notifications, refer to *System Automation for OS/390 Messages and Codes*.

**Restrictions and Limitations**

Any changes you make using the INGNTFY command are in effect only until the automation control file is reloaded.

The INGNTFY command can only be used when SA OS/390 is initialized.

**Examples**

To turn your messages off, type `ingntfy off`.

To add notification operator Jim, assign him all messages in class 43, and hold Immediate Action type messages on his screen, type:

```
ingntfy add jim class=43 heldmsg=a
```

If you type `ingntfy`, a panel similar to the following is displayed:

```

AOFKAASN                SA OS/390 - Command Dialogs
Domain ID = IPSNO      ----- INGNTFY -----      Date = 02/17/00
Operator ID = NETOP1                                     Time = 15:52:54

Specify operator notification settings:
Status/Action =>                Operator status:
                                ON      - Set your notifications ON
                                OFF      - Set your notifications OFF
                                ADD      - Add or Modify an operator
                                DELETE   - Remove an operator
                                QUERY    - Look up an operator
Operator ID  =>                Operator for ADD, DELETE or QUERY
Classes     =>                Up to 10
Description =>

Held Messages - Information    =>      Immediate Action    =>
                  Eventual Action =>      Immediate Decision  =>
                  System Wait    =>

System         =>                System name, domain ID or sysplex name

Command ==>>
PF1=Help      PF2=End          PF3=Return
                                           PF6=Roll
                                           PF12=Retrieve

```

Figure 63. INGNTFY Command Dialog Panel

**INGOPC****Purpose**

The INGOPC command lets you:

- Display Application, Operation, Special Resource, Work Station and Calendar information from the Current Plan.
- Modify Application, Operation, Special Resource, Work Station information in the Current Plan.
- Issue a request against any controller defined to SA OS/390 in a sysplex.
- Issue a request against a foreign controller where the local tracker is defined to SA OS/390.

## INGOPC

- The output of the INGOPC command is either full screen or in pipeable line mode.

### Syntax

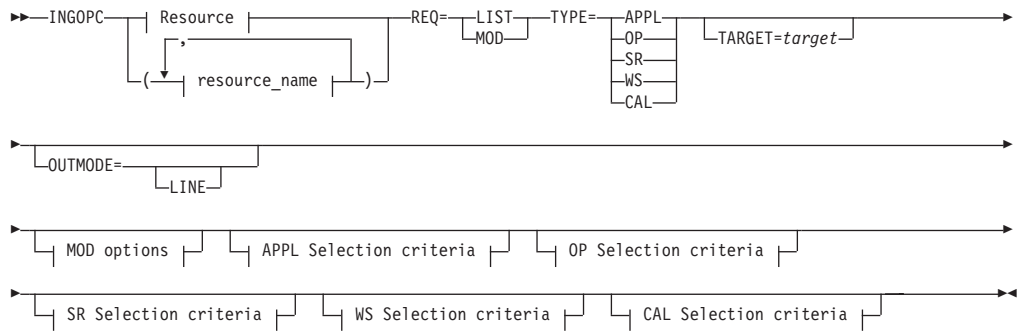

### MOD options:



### APPL Selection criteria:



### OP Selection criteria:

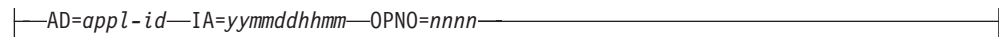

### SR Selection options:



### WS Selection options:



### CAL Selection options:



## Parameters

### resource

The resource specifies the OPC controller that is to be queried or modified. Multiple specifications are allowed as well as system and sysplex application groups. Wildcards % and \* are supported.

The command attempts to resolve the specification to a single appropriate target resource. In all cases the groups are resolved to their members and wildcards are resolved to specific sets of resources.

The resulting list of resources is scanned to check whether there is an active controller. The first active controller found is used. If no active controllers are found the list is scanned to check whether there is a tracker. The first tracker found is used.

If an active controller could be found a command is dispatched to the appropriate system in the sysplex to execute the OPC API on the same system as the active controller. If a tracker was found, the LUNAME parameter of the trackers OPCCNTL entry may be used to specify a remote controller. In this case the command is dispatched to the system where the tracker is running and the APPC API is used to connect to the remote controller from that system.

### REQ

Specifies the request to be issued to the OPC subsystem. It can be one of the following:

**LIST** Lists OPC Current Plan resources.

**MOD** Modifies OPC Current Plan resources.

### TYPE

Specifies the type of Current Plan resource to be listed or modified. It can be one of the following:

**APPL** Specifies the Current Plan Application Description resource.

**OP** Specifies the Current Plan Operation resource.

**SR** Specifies the Current Plan Special Resource.

**WS** Specifies the Current Plan Workstation resource.

**CAL** Specifies the Current Plan Calendar resource.

### UPDATE

Specifies the fields that are to be updated and the new contents of the field. Multiple fields can be specified separated by semi-colon ";". The names of the fields are the same names as specified in the MODIFY command arguments in *TWS for z/OS Programming Interfaces*.

An alternative to specifying all the fields to be updated using the UPDATE= parameter is to specify the fields and their contents in the default SAFE.

Specify one field per message with the format of <fieldname><blank>=<blank><contents>The blanks between the fieldname and the = symbol and the = symbol and the contents are required.

### AD

Specifies the Application Description selection criteria. For LIST requests, this may contain the trailing "\*" wildcard character. For MOD requests, this must be the exact name of the application description to be updated.

**IA** Specifies the input arrival date/time of the application. The format is as specified by the system programmer when installing and customizing OPC. The default format is YYYYMMDDHHMM.

### OPNO

Specifies the operation number selection criteria. This is the operation number of an operation in an application description.

### SRNAME

Specifies the Special Resource selection criteria.

## INGOPC

For LIST requests, this may contain the trailing "\*" wildcard character. For MOD requests, this must be the exact name of the special resource.

### WSNAME

Specifies the workstation name selection criteria.

For LIST requests, this may contain the trailing "\*" wildcard character. For MOD requests, this must be the exact name of the workstation.

### CAL

Specifies the Calendar Name selection criteria. For LIST requests, this may contain the trailing "\*" wildcard character. For MOD requests, this must be the exact name of the calendar.

### TARGET

For information on the TARGET parameter, refer to "Additional Parameters for System Operations Commands" on page 10.

### OUTMODE

For information on the OUTMODE parameter, refer to "Additional Parameters for System Operations Commands" on page 10.

## Restrictions and Limitations

To use the INGOPC command system operations must be initialized.

## Usage

The INGOPC command operates sysplex-wide. For an overview refer to "Overview of Commands that Operate Sysplex-Wide" on page 9.

## Examples

If you type INGOPC a panel similar to the following is displayed:

```
EVIJKYRQ0          SA OS/390 - Command Dialogs
Domain ID   = IPSFM  ----- INGOPC -----   Date = 04/10/02
Operator ID = NETOP1                               Time = 16:15:27

Resource  =>                               format: name/type/system
System    =>                               System name, domain ID or sysplex name

Request   =>                               Request type (LIST/MODIFY)
Type      =>                               Type of resource (APPL/OP/SR/WS/CAL)

Command ===>
PF1=Help   PF2=End   PF3=Return

                                           PF6=Roll
                                           PF12=Retrieve
```

Figure 64. INGOPC Command Dialog Panel

- The resource field shows the name of the OPC active controller subsystem to be used for issuing the requests. The format is name/type[/system]. Wildcards are supported.
- The System field shows the name of the system (system name, domain ID, or sysplex name) to which the command should be routed. Specifying this is only necessary if the resources do not reside on the local sysplex.

- The Request field shows the request to be carried out. It can be LIST or MODIFY.
- The Type field shows the type of OPC Current Plan resource to be specified.

If you specify INGOPC \* REQ=LIST TYPE=APPL a panel similar to the following is displayed:

```

INGKYSTO          SA OS/390 - Command Dialogs  Line 1  of 65
Domain ID  = IPSFM  ----- INGOPC  -----   Date = 04/10/02
Operator ID = AFRANCK      Sysplex = KEY1PLEX      Time = 16:19:30
CMD: A Update      B Operations                               / scroll
                                Application Occurrence List
                                Input Arrival      Error
CMD  Application Id  Date      Time  Status  Code  Description
-----
JKOPCTST1          02/01/23 00:01 Completed      Test Batch Iface
JKTEST1            02/01/23 00:08 Completed      This is a test
JKOPCTST1          02/01/24 00:01 Completed      Test Batch Iface
JKTEST1            02/01/24 00:08 Completed      This is a test
IEFBR14            02/01/24 08:01 Completed      This is a test
JKOPCTST1          02/01/25 00:01 Starting       Test Batch Iface
JKTEST1            02/01/25 00:08 Completed      This is a test
IEFBR14            02/01/25 08:01 Completed      This is a test
JKOPCTST1          02/01/26 00:01 Error          Test Batch Iface
JKTEST1            02/01/26 00:08 Completed      This is a test
IEFBR14            02/01/26 08:01 Completed      This is a test
JKOPCTST1          02/01/27 00:01 Error          Test Batch Iface
JKTEST1            02/01/27 00:08 Completed      This is a test

Command ==>
PF1=Help  PF2=End      PF3=Return      PF5=Filters  PF6=Ro11

```

Figure 65. INGOPC REQ=LIST TYPE=APPL Sample Panel

If you specify INGOPC \* REQ=LIST TYPE=OP a panel similar to the following is displayed:

```

INGKYSTO          SA OS/390 - Command Dialogs  Line 1  of 3
Domain ID  = IPSFM  ----- INGOPC  -----   Date = 04/10/02
Operator ID = NETOP1      Sysplex = KEY1PLEX      Time = 16:23:08
CMD: A Update                               / scroll
                                Operations List
                                Op. -----JES-----
                                Op. Num. Name      Number  Status  Reason
CMD  -----
-----
1  EVJSJ001          Completed      NV01
1  JKTST1            JOB06429 Completed      N001
1  IEFBR14           JOB00325 Completed      CPU1
1  EVJSJ001          JOB07522 Completed      N001
1  JKTST1            JOB07521 Completed      N001
1  IEFBR14           JOB07523 Completed      CPU1
1  EVJSJ001          JOB00787 Interrupt     N001
1  JKTST1            JOB07524 Completed      N001
1  IEFBR14           JOB07526 Completed      CPU1
1  EVJSJ001          JOB07528 Error          JCL N001
1  JKTST1            JOB07527 Completed      N001
1  IEFBR14           JOB07529 Completed      CPU1
1  EVJSJ001          JOB07533 Error          JCL N001

Command ==>
PF1=Help  PF2=End      PF3=Return      PF5=Filters  PF6=Ro11

```

Figure 66. INGOPC REQ=LIST TYPE=OP Sample Panel

If you specify INGOPC \* REQ=LIST TYPE=SR a panel similar to the following is displayed:

# INGOPC

```

INGKYSTO          SA OS/390 - Command Dialogs Line 1 of 26
Domain ID = IPSFM ----- INGOPC ----- Date = 04/10/02
Operator ID = NETOP1 Sysplex = KEY1PLEX Time = 16:27:11
CMD: A Update / scroll

Special Resources List
CMD Name --Actual-- -Default--
Av. Quant. Av. Quant.
-----
ING.KEY1.APL.CICSK1G.DOWN No 1 Yes 1
ING.KEY1.APL.CICSK1G.UP No 1 Yes 1
ING.KEY1.APL.RMF.DOWN No 1 Yes 1
ING.KEY1.APL.RMF.UP Yes 1 Yes 1
ING.KEY1.APL.RMFIII.DOWN No 1 Yes 1
ING.KEY1.APL.RMFIII.UP Yes 1 Yes 1
ING.KEY2.APL.CICSK1G.DOWN Yes 1 Yes 1
ING.KEY2.APL.CICSK1G.UP No 1 Yes 1
ING.KEY2.APL.RMF.DOWN No 1 Yes 1
ING.KEY2.APL.RMF.UP Yes 1 Yes 1
ING.KEY2.APL.RMFIII.DOWN No 1 Yes 1
ING.KEY2.APL.RMFIII.UP Yes 1 Yes 1
ING.KEY3.APL.CICSK1G.DOWN Yes 1 Yes 1

Command ==>
PF1=Help PF2=End PF3=Return PF5=Filters PF6=Ro11

```

Figure 67. INGOPC REQ=LIST TYPE=SR Sample Panel

If you specify INGOPC \* REQ=LIST TYPE=WS a panel similar to the following is displayed:

```

INGKYSTO          SA OS/390 - Command Dialogs Line 1 of 7
Domain ID = IPSFM ----- INGOPC ----- Date = 04/10/02
Operator ID = NETOP1 Sysplex = KEY1PLEX Time = 16:29:02
CMD: A Update / scroll

Work Stations List
Reporting JCL Alt. Para.
Attribute Prep STC WTO ReRoute WS Server
-----
NV02 Unknown General Automatic No No No No No
NV03 Unknown General Automatic No No No No No
OPR1 Unknown General Completion No No No No No
WT01 Active General Automatic No No Yes No No
NV01 Unknown General Automatic No No No No No
CPU1 Active Computer Automatic No No No No No
N001 Active Computer Automatic No No No No No

Command ==>
PF1=Help PF2=End PF3=Return PF5=Filters PF6=Ro11

```

Figure 68. INGOPC REQ=LIST TYPE=WS Sample Panel

If you specify INGOPC \* REQ=LIST TYPE=CAL a panel similar to the following is displayed:

```

INGKYSTO          SA OS/390 - Command Dialogs Line 1 of 2
Domain ID = IPSFM ----- INGOPC ----- Date = 04/10/02
Operator ID = NETOP1 Sysplex = KEY1PLEX Time = 16:31:46
CMD: / scroll

                          Calendar List

CMD  Name          Days Shift Description
-----
APC          7 0000 general APC calendar
DEFAULT     8 0000 general APC calendar

Command ==>
PF1=Help   PF2=End   PF3=Return   PF5=Filters   PF6=Roll

```

Figure 69. INGOPC REQ=LIST TYPE=CAL Sample Panel

Press PF10 and PF11 to display more information for each resource type. Issuing the command code A Update command against a resource in the CMD field displays a panel which lets you modify the resource. The Application Description list supports the B Operations command code. Issuing this command code against an application resource displays a list of operations for that resource. SORT/FIND/RFIND commands are supported. Refer to “Deciding the Format of the Command Output (Full-Screen only)” on page 13 for further information.

Pressing PF5 displays a filter selection panel similar to the following:

```

EVJKFLT          SA OS/390 - Command Dialogs
Domain ID = IPSFM ----- EVJFILT ----- Date = 04/10/02
Operator ID = NETOP1 Time = 16:36:48

Specify or revise the filter criteria:

Active Controller ==> OPCF/APL/KEY1
OPC/OPC resource ==> CAL          APPL, OP, SR, WS or CAL

Generic Filter strings in the format NAME = value
==>                               ==>
==>                               ==>
==>                               ==>
==>                               ==>
==>                               ==>
==>                               ==>
==>                               ==>
==>                               ==>
==>                               ==>
==>                               ==>

Command ==>
PF1=Help   PF2=End   PF3=Return   PF4=Clear   PF5=Reset   PF6=Roll

```

Figure 70. INGOPC Filter Sample Panel

Specify filter strings in the format *field-name op contents* where:

- *field-name* is a valid field name as specified by the MODIFY command arguments in *TWS for z/OS Programming Interfaces*.

## INGOPC

- *op* can have the following values:

=  
^=  
<  
<=  
>  
>=

- *contents* are the desired values to be matched by the *op*. The trailing wildcard character '\*' may be used for *op*.

The operands must be separated by a blank.

## INGPLEX

### Purpose

The INGPLEX command comprises all the sysplex-related functions of SA OS/390. It can be called in full mode and in line mode. If it is called in line mode, only the display functions are available.

### Syntax

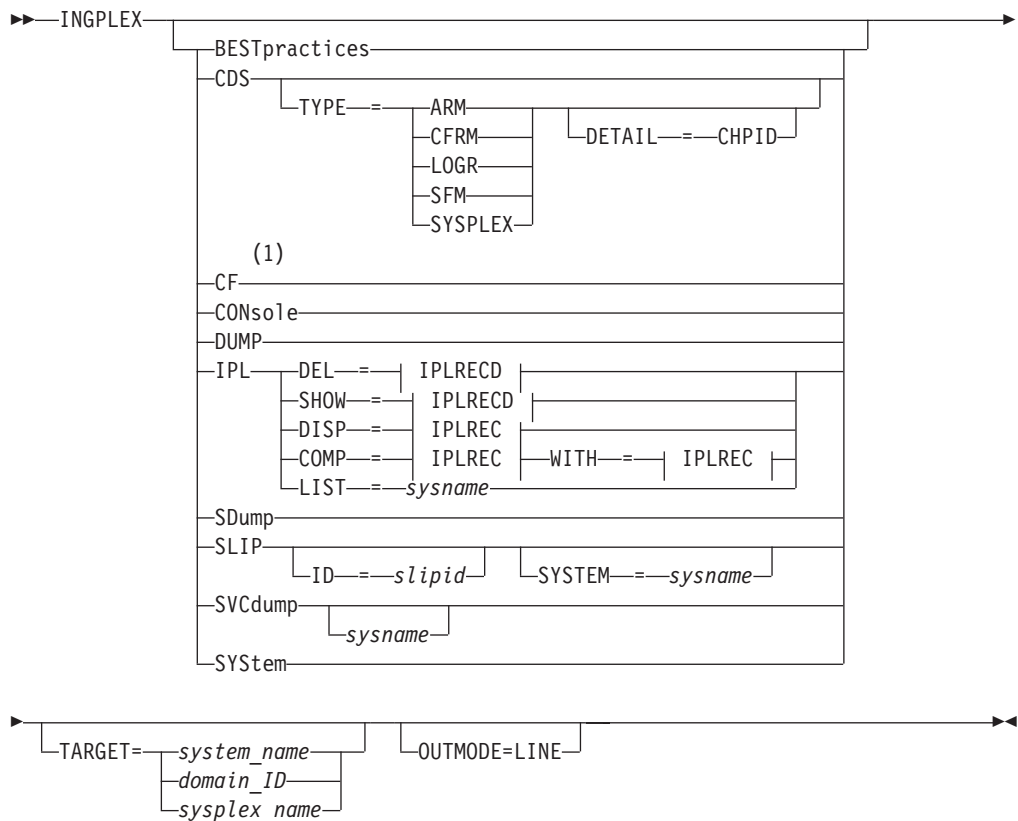

### IPLREC:

|---sysname---|/---timestamp---|/---member---|/---suffix---|

**IPLRECD:**

|—*sysname*—/—*timestamp*—|

**Notes:**

- 1 For details see “INGCF” on page 73.

**Parameters****BESTpractices**

Displays information about the currently active HealthChecker best practices. This information is retrieved from the system that performs the global and local checks.

**CDS**

Displays information about CDSs and supports replacement of the current alternate CDS by a new one as well as making the alternate CDS the new primary. For further information about INGPLEX CDS refer to “CDS” on page 138.

**TYPE**

The type of CDS for which the CDS function is issued. Possible values are ARM, CFRM, LOGR, SFM, and SYSPLEX.

**DETAIL**

If you specify this parameter with the CDS function, the channel paths for the respective CDS type are displayed.

**CF**

This is the equivalent of the INGCF command.

**CONsole**

Displays information about consoles.

**DUMP**

Shows the DUMP submenu.

**IPL**

Shows and compares IPL information. It can be issued with the following options:

**DEL**

Deletes a single IPL record and all its related information. Note that the DEL parameter is supported in line mode only.

**SHOW**

Shows the details panel of the specified IPL record.

**DISP**

Shows all, one, or particular PARMLIB members used by the IPL of the specified system and at the specified date and time.

**COMP**

Compares all, one, or particular PARMLIB members used by the IPL of the specified system and at the specified date and time with those specified in the WITH parameter.

**LIST**

Shows the IPL summary records of the specified system.

## INGPLEX

### WITH

The COMP parameter compares all, one, or particular PARMLIB members used by the IPL of the specified system, at the specified date and time with those specified in parameter WITH.

#### *sysname*

Is the name of the system in the sysplex.

### timestamp

Is the IPL date and time. The format is YYYYMMDDhhmm.

#### *member*

Is the name of the PARMLIB member without the suffix.

### suffix

Is the suffix of the PARMLIB member.

For further information about INGPlex IPL refer to "IPL" on page 147.

### SDUMP

Displays and controls the SDUMP options being set on all systems in the sysplex. For further information about INGPlex SDUMP refer to "SDUMP" on page 148.

### SLIP

Displays and controls all SLIP traps of all systems in the sysplex. Controlling is limited to DISABLE, ENABLE, or REMOVE a SLIP trap. The following parameters are supported:

**ID** Limits the line mode output and the initial full screen display to the particular SLIP trap ID

#### *slipid*

Is the ID of a SLIP trap. It can consist of one to four characters. Wildcards are not supported.

### SYSTEM

Limits the line mode output and the initial full screen display to the particular system.

For further information about INGPlex SLIP refer to "SLIP" on page 153.

### SVCDUMP

Allows you to issue a multisystem dump of up to 15 address spaces including data spaces owned by the address spaces, structures used by the address spaces, and XCF group members on the same or on other systems in the sysplex of those groups the address spaces have joined. The following parameter is supported:

#### **sysname**

Is the name of the system having joined the XCF group of the NetView the operator is logged on to.

For further information about INGPlex SVCDUMP refer to "SVCdump" on page 151.

### SYStem

Displays information about a member system of the sysplex.

### TARGET

For information on the TARGET parameter, refer to "Additional Parameters for System Operations Commands" on page 10.

**OUTMODE**

For information on the OUTMODE parameter, refer to “Additional Parameters for System Operations Commands” on page 10.

**Example**

If you specify INGPLEX without parameters, the following selection panel is displayed:

```

INGLX000                SA OS/390 - Command Dialogs
Domain Id = IPSFM      ----- INGPLEX -----
Operator Id = HIR
Date = 07/20/02
Time = 23:26:27

Sysplex . . . . . : KEY1PLEX

Select the desired command:                                INGPLEX ...

  1 Display systems (including ETR & signalling paths)      SYStem
  2 Display consoles                                       CONSOLE
  3 Control coupling facilities                             CF
  4 Control couple data sets                               CDS

  6 Display IPL information                                IPL
  7 Control dumps                                         DUMP
  8 Health Checker best practices                         BESTpractices
  9 Health Checker results

Command ==>
F1=Help      F2=End      F3=Return
F6=Roll      F12=Retrieve

```

Figure 71. INGPLEX selection panel

Specify the number or the function and press Enter.

**BESTpractices**

**Purpose:** This command allows you to view the currently active best practices from the system doing global checks, which is shown on the panel.

**Example:** When you issue the INGPLEX BEST command, to display the IBM and User-defined best practices, the panel in Figure 72 on page 136 is displayed.

```

INGLX351          SA OS/390 - Command Dialogs          Line 139 of 217
Domain ID = IPXNH      -- INGPLEX BESTPRACTICES --      Date = 04/10/03
Operator ID = KHH                                           Time = 09:50:09

System . . . . . ==> KEYB                      Sysplex . . . . . : KEYAPLEX
-----
Check
  Keyword      IBM policy value                      D User policy value
-----
AVAILABLE_FRAME_QUEUE_THRESHOLDS
Severity..: High
Parms.....: 400,600,200,400          * 401,601,201,401
Interval...: 24:00                    * 0:10
Version...: HBB7703
Date.....: 20030211                  * 20030410
Reason....: System may not recover in time * WE NEED OTHER PARAMETERS FOR
              if set too low           * OUR SYSTEM
REAL_STORAGE_AVAILABILITY
Severity..: Low
Interval...: 24:00

Command ==>
F1=Help      F2=End      F3=Return          F6=Roll
F7=Backward  F8=Forward   F9=Refresh        F12=Retrieve
    
```

Figure 72. INGPLEX BESTpractices panel

This panel displays the IBM’s and user best practices of the HealthChecker function. The following fields are shown in the non-scrollable area of the screen.

- System**            Name of the system from which the best practices are retrieved.  
  
The best practices can only be retrieved from a system where the HealthChecker function is active. If multiple systems are eligible, the system where the checks with sysplex scope (global checks) are done is chosen by default.  
  
You may choose another system by overtyping the system name with the name of the desired system. If the system name is cleared, the best practices are retrieved from the default system.
- Sysplex**           Name of the sysplex that the system named above is part of.

The scrollable area of the screen lists the IBM best practice recommendation and, if defined, the user override value.

- Check**            Best practice checkname is displayed in white.
- Keyword**          Associated keywords for a check are displayed below the checkname.
- IBM policy value**  
Details the IBM Bestpractice value. The following values are defined:
  - Severity**        Expresses a sense of urgency about the need to fix the exceptional situation for the check. Possible values are High, Medium, Low.
  - Parms**            IBM’s recommended settings for the check.
  - Interval**        IBM’s recommendation of how often to perform the check. The time interval is shown in the format *hh:mm*.

<b>Version</b>	Shows the FMID of the operating system release for which the check is applicable. This can be a range.
<b>Date</b>	Shows the date when IBM introduced or last modified the check.
<b>Reason</b>	Documents the reason why the check should be done.

**D** An asterisk in this column represents a discrepancy between the IBM recommended value and a User override.

#### User policy value

Details the user override values. The following values can be overridden:

- Parms, where applicable
- Interval
- Date
- Reason
- Severity

The value for Interval is also used to mark checks which are not performed on the system for the following reasons:

#### **NOCALL specified**

Indicates that in the user policy the check is specified explicitly with NOCALL.

#### **NOCALL - Check failed**

Indicates the checker failed 3 times.

#### **NOCALL - System error**

Indicates an unrecoverable system error in this check. It might also indicate an error in the IBM Parms.

#### **NOCALL - User Error**

Indicates an error in the user parms for this check.

#### **NOCALL - n/a**

Indicates the check is not applicable on the system. For example if the system is set up in Monoplex mode, certain checks are not applicable.

#### **NOCALL - Global check n/a**

Indicates that the check is not executed because some other system performs the global checks.

#### **NOCALL - ?????**

Indicates that the check is not executed for some undefined reason.

When a User value does not match an IBM recommended value, along with the discrepancy flag, the user value is displayed in a different color.

The display of a particular keyword is suppressed if it is not applicable to the check.

## CDS

**Purpose:** The CDS function displays information about all the couple data sets in the system, including details of the corresponding policies. For every CDS type that is required by the implementation INGPLEX CDS allows the operator to:

- Switch from the primary to the alternate CDS
- Define a new alternate CDS
- Change the active policy (if applicable)

Actions are started by specifying an action code for a selected CDS type on the panel.

**Actions:** The possible action codes are:

### **\*allocate alternate CDS (A)**

Replaces the current alternate CDS for a selected CDS type by a new one. There are two options how to do this:

- The alternate CDS is allocated automatically by SA OS/390.  
This automatic allocation requires that spare volumes have been defined, and that one of these spare volumes is available.
- Specify the data set that is to be used as the new alternate CDS.  
If you specify your own data set, observe the following:
  - The data set must exist
  - It must have been formatted with the XCF formatting tool
  - It must be at least as large as the current primary CDS, which means that every value you have passed to the XCF formatting tool (for example, in the case of a sysplex CDS, the maximum number of systems supported) must be equal to or greater than the corresponding value of the primary CDS.

### **display CHPIDs (C)**

Displays information about the channel paths for the selected CDS type.

### **display CDS information (I)**

Displays detail information about the selected CDS type. This comprises the formatting parameters and the policies that are contained in the CDS, if applicable. When the CDSs of the selected type contain policies, the detail information panel provides further actions, namely:

#### **display policy (D)**

Displays details about the selected policy.

#### **start policy (S)**

Makes the selected policy the active policy.

The policy switch must be confirmed before it is executed.

### **\*switch alternate CDS to primary CDS (P)**

Makes the alternate CDS the primary one. Because an alternate CDS is no longer available after the switch, SA OS/390 shows a confirmation panel before the action is performed. On the panel, you can specify a new alternate CDS. When CDS recovery is switched on and you do not supply your own alternate CDS, SA OS/390 tries to allocate a new alternate CDS automatically. The special requirements for manual and automatic creation of the new alternate CDS are the same as those for the replacement of the alternate CDS (action code A).

**Examples:** The following example illustrates the switch from the primary to the alternate CDS.

The following examples start with issuing INGPLEX CDS and pressing F8 on the CDS command dialog to scroll down the CDS list. The following panel is displayed:

```

INGKX300          SA OS/390 - Command Dialogs      Line 7   of 18
Domain ID   = IPSFO  ----- INGPLEX CDS -----   Date = 03/01/01
Operator ID = NETOP1      Sysplex = KEY1PLEX      Time = 10:08:10

System...: KEY3          Interval...: 86400          OPNotify: 86400
Maxmsg...: 999999       Cleanup....: 60          Retry...: 255
Classlen: 956           Max CFlevel: 9          COUPLExx: COUPLER1
SMREBLD.: 1            Max SMlevel: 9

Cmds: A allocate alternate CDS / C display CHPIDs
      D display CDS information / P switch alternate CDS to primary CDS

  Type      MS   Volume  Dev   Couple Dataset Name
  -----
-  CFRM
  PRIMARY...: 16  KEY1SP  260B  SYS1.KEY1.PXESCDS
  ALTERNATE: 16  KEYUSR  261C  SYS1.KEY1.AXESCDS
-  LOGR
  PRIMARY...: 8   KEY1SP  260B  SYS1.KEY1.PLOGCDS
  ALTERNATE: 8   KEYUSR  261C  SYS1.KEY1.ALOGCDS

Command ==>
F1=Help      F2=End      F3=Return   F6=Roll
PF7=Back     PF8=Forward F9=Refresh  F12=Retrieve

```

Figure 73. INGPLEX CDS dialog panel

The panel header contains sysplex-related information about the system on which the INGPLEX command was executed. The details are as follows:

- The **System** field shows the name of the system.
- The **Interval** field shows the system failure detection interval in seconds. This interval is the amount of time XCF lets elapse without a status update before assuming that the system failed.
- The **OPNotify** field shows the number of seconds that XCF waits before notifying the operator of a potential system problem.
- The **Maxmsg** field shows the default value for the maximum amount of kilobytes of message buffer space. This default value is used when MAXMSG is not specified on SETXCF START commands.
- The **Cleanup** field shows the number of seconds that XCF waits for cleanup of members.
- The **Retry** field shows the default value for the retry limit. This value is used when the RETRY keyword is not specified on SETXCF START commands.
- The **Classlen** field shows the default length (in bytes) of messages allowed for a transport class. This value is used when CLASSLEN is not specified on the SETXCF START CLASSDEF command.
- The **Max CFlevel** field shows the maximum CFLEVEL supported by this system. This system can connect to a coupling facility with a higher CFLEVEL than the value of **Max CFlevel** but would not be enabled to use any functions supported by the higher level coupling facility.
- The **COUPLExx** field shows the COUPLExx Parmlib member used for system IPL.
- The **SMRBLD** field shows whether (value 1) or not (value 0) system-managed rebuild has been activated in the CFRM couple dat set.

## INGPLEX CDS

- The **Max SMlevel** field shows the maximum system-managed process level supported by this system.

The main part of the screen shows information about the primary and alternate CDSs for every CDS type. Press F8 to scroll and display further entries. The **MS** column shows the maximum number of systems that are supported by the CDS.

*Making an alternate CDS the primary CDS:* In this example, the alternate LOGR couple data set is made the new primary CDS. A new alternate CDS is automatically generated.

To switch the LOGR couple data set, enter P before LOGR on the panel displayed in Figure 73 on page 139, and press ENTER. INGPLEX CDS displays the following confirmation panel:

```
INGKX30A          SA OS/390 - Command Dialogs
Domain ID   = IPSFO      ----- INGPLEX CDS -----      Date = 03/01/01
Operator Id = NETOP1    Sysplex = KEY1PLEX                    Time = 10:08:13

                               SETXCF PSWITCH Confirmation

You are going to remove the LOGR   primary couple data set.
The alternate couple data set  SYS1.KEY1.ALOGCDS
becomes the primary as soon as you proceed with the GO function key.
Immediately after the switch, automation will try to allocate a new alternate
couple data set on one of the spare volumes defined during the customization.
If you want the automation to allocate your own alternate couple data set
complete the necessary information below.

Your alternate couple dataset...

Name   ==>

Volume ==>

Command ==>
          F2=End      F3=Return      F6=Ro11
          F10=Go     F11=Cancel  F12=Retrieve
```

Figure 74. Confirmation panel for switching from the current primary CDS to the alternate CDS

Use this panel to determine how a new alternate CDS is to be created after the switch. You can either specify your own new alternate CDS or let SA OS/390 create it for you. When you specify the new alternate CDS yourself, the data set must exist and must have been formatted with the XCF formatting tool. Automatic creation requires that spare volumes have been defined for LOGR couple data sets.

Pressing F10 causes SA OS/390 to generate the new alternate CDS. After returning to the CDS command dialog, refreshing the panel, and scrolling down with F8, the panel looks as follows:

```

INGKX300          SA OS/390 - Command Dialogs      Line 7   of 18
Domain ID   = IPSFO          ----- INGPLEX CDS -----   Date = 03/01/01
Operator ID = NETOP1        Sysplex = KEY1PLEX                               Time = 10:08:25

System...: KEY3              Interval...: 86400              OPNotify: 86400
Maxmsg...: 999999           Cleanup....: 60                 Retry...: 255
Classlen: 956               Max CFlevel: 9                  COUPLExx: COUPLER1
SMREBLD.: 1                 Max SMlevel: 9

Cmds: A allocate alternate CDS / C display CHPIDs
      D display CDS information / P switch alternate CDS to primary CDS

Type      MS   Volume  Dev   Couple Dataset Name
-----
-  CFRM
  PRIMARY...: 16  KEY1SP  260B  SYS1.KEY1.PXESCDS
  ALTERNATE: 16  KEYUSR  261C  SYS1.KEY1.AXESCDS
-  LOGR
  PRIMARY...: 8   KEYUSR  261C  SYS1.KEY1.ALOGCDS
  ALTERNATE: 8   AOCUSR  262B  AOC.CDS.TEST.LOGR.CDS02

Command ==>
F1=Help      F2=End      F3=Return      F6=Ro11
PF7=Back     PF8=Forward  F9=Refresh     F12=Retrieve

```

Figure 75. INGPLEX CDS dialog panel after the switch

The previous alternate LOGR CDS has become the primary, and there is a new alternate, which was created by SA OS/390.

*Switching the CFRM policy:* In this example, the active CFRM policy is switched.

Enter D before CFRM on the panel displayed in Figure 73 on page 139, and press ENTER. The following panel is displayed:

```

INGKX311          SA OS/390 - Command Dialogs      Line 1   of 5
Domain ID   = IPSFO          ----- INGPLEX CDS -----   Date = 03/01/01
Operator ID = NETOP1        Sysplex = KEY1PLEX                               Time = 10:13:13
                                CFRM Couple Data Set Information

Data Set Information
Volume Device FORMAT TOD          Data Set Name
-----
KEY1SP 260B 08/29/2000 08:51:30 SYS1.KEY1.PXESCDS
KEYUSR 261C 08/29/2000 08:47:42 SYS1.KEY1.AXESCDS
Control Card Information
MS POLICY CF STR CONNECT SMREBLD SMDUPLEX
-----
16      8  4  64      16      1      0
Policy Information
Cmds: D display policy / S start policy
Name      CF Str Date      Time      Userid
-----
- BZOEPOL ACTIVE 2  19 02/10/2001 10:05:47 BZOE
- HIRPOL   2  19 02/19/2001 19:45:57 HIR
- HIRPOL1  1  8  08/25/2000 09:20:04 HIR

Command ==>
F1=Help      F2=End      F3=Return      F6=Ro11
PF8=Forward  F9=Refresh     F12=Retrieve

```

Figure 76. CFRM couple data set information panel before policy switch

The panel shows information about the names and locations of the CDSs. The panel also shows the parameters that were used by the formatting tool of XCF for the allocation of the CDS. The **POLICY** field, for example, displays the maximum number of policies the CDS can contain. Furthermore, the panel shows information

## INGPLEX CDS

about the policies in the CDS, for example, how many coupling facilities and structures are defined in every policy, and which policy is currently active.

To switch to the HIRPOL policy, enter S before this policy and press ENTER. INGPLEX CDS displays the following confirmation panel:

```

INGKX30C          SA OS/390 - Command Dialogs          Date = 03/01/01
Domain ID   = IPSFO  ----- INGPLEX CDS -----          Time = 10:13:17
Operator Id = NETOP1          Sysplex = KEY1PLEX

                                SETXCF START   Confirmation

You are going to start a new CFRM   CDS policy named  HIRPOL   .

The current policy

                                BZOEPOL

will be stopped as soon as you proceed with the GO function key,

Command ==>>
                                F2=End           F3=Return           F6=Ro11
                                                F10=Go           F11=Cancel       F12=Retrieve
  
```

Figure 77. Confirmation panel for policy switch

*Displaying the channel paths for a CDS type:* In this example, the channel paths for the CFRM couple data sets are displayed.

Enter C before CFRM on the panel displayed in Figure 73 on page 139, and press ENTER. The following panel is displayed:

```

INGKX318          SA OS/390 - Command Dialogs          Line 1   of 4
Domain ID   = IPSFO  ----- INGPLEX CDS -----          Date = 03/02/01
Operator ID = NETOP1          Sysplex = KEY1PLEX          Time = 08:05:46

                                CFRM Channel Path Information

System  T  DEVN  CHPIDs                                     SSID
-----  -  ----  -----
KEY1    P  260A  E4=+ E5=+ E2=+ E3=+                               2600
        A  2610  E4=+ E5=+ E2=+ E3=+                               2600
KEY2    P  260A  E4=+ E5=+ E2=+ E3=+                               2600
        A  2610  E4=+ E5=+ E2=+ E3=+                               2600
KEY3    P  260A  E4=+ E5=+ E2=+ E3=+                               2600
        A  2610  E4=+ E5=+ E2=+ E3=+                               2600
KEY4    P  260A  13=+ 22=+ 30=+ 94=+                            2600
        A  2610  13=+ 22=+ 30=+ 94=+                            2600

Command ==>>
F1=Help           F2=End           F3=Return           F6=Ro11
F9=Refresh                                     F12=Retrieve
  
```

Figure 78. Channel path information for CFRM couple data sets

- The System column shows the name of the sysplex members.

- The T column (for 'type') indicates whether the CDS is the primary (value 'P') or alternate (value 'A').
- The DEVN displays the number of the device on which the CDS resides.
- The CHPIDs column shows the status of the paths to the devices in the format *chpid=status\_code*. The codes are those of the operating system. They have the following meaning:
  - + The path is logically and physically available and I/O on the path was successful.
  - \* The path is physically, but not logically available. The subchannel's logical path indicator is off but I/O to the path is successful. You can use the command `VARY PATH (ddd,nn),ONLINE` to make channel path *nn* logically available to device *ddd*.
  - The path is neither logically nor physically available. The subchannel's logical and physical indicators are both off for this channel path. You can use the command `CONFIG CHP(nn),ONLINE` to make the channel path logically available to all devices connected to the channel.
  - & The device is reserved to another path. This indicator applies to devices with the dynamic pathing selection feature.
  - < The path is installed but not physically available. The start subchannel request received a condition code of 3.
  - > The device microcode has detected an error and will not allow I/O to complete on the path.
  - B The path is unable to communicate. The device indicates that a busy or reserve condition exists on the path.
  - C A controller error occurred while accessing the device.
  - D A device error occurred while accessing the device.
  - I Intervention is required; the device is not ready.
  - R The path is available and the device is reserved to this path/group. This only applies to devices with the dynamic pathing feature.
  - T A time out has occurred; there is no response from the device. The cause of the time out is undetermined and this condition is transient.
  - U A storage control unit or storage director error occurred while accessing the device.
  - X Unable to determine the failing unit.
- The SSID field displays the storage subsystem to which the device belongs.

## SYStem

**Purpose:** The SYSTEM function displays the target sysplex name, its GRS mode and its member systems.

## INGPLEX SYSTEM

### Example:

```

A0FKX100          SA OS/390 - Command Dialogs          Line 1   of 4
Domain ID  = IPSFP  ----- INGPLEX SYSTEM -----      Date = 03/05/01
Operator ID = NETOP1                                     Time = 09:44:37

Sysplex . . . . . : KEY1PLEX
GRS Mode  . . . . . : STAR

Display more info: C CPU  E ETR  I IPL  O IOS  S STOR/ESTOR
Signalling Path : D device T structure

Monitor
Cmd  System    Status   Timestamp  INTERVAL  Action    SSUM  -----
-----
-   KEY1      ACTIVE   09:44:34   86400     ISOLATE   50    50
-   KEY2      ACTIVE   09:44:35   86400     ISOLATE   50    15
-   KEY3      ACTIVE   09:44:34   86400     ISOLATE   50    15
-   KEY4      ACTIVE   09:44:36   86400     ISOLATE   50    15

Command ==>
F1=Help      F2=End          F3=Return      F6=Roll
              F9=Refresh      F12=Retrieve
  
```

Figure 79. INGPLEX SYSTEM dialog panel

The following command codes are available:

- C** Displays the online or offline status of one or more processors and any vector facilities, or ICRFs attached to those processors
  - E** Displays the timer synchronization mode and ETR ports
  - I** Displays IPL information
  - O** Displays IOS-related configuration information
  - S** Displays the number of megabytes of central and expanded storage assigned and available to the system
  - D** Displays the device number of one or more in-/outbound signalling paths that XCF can use and information about in-/outbound XCF signalling paths to this system
  - T** Displays detailed signalling path information for all coupling facility structures
    - The Sysplex field shows the name of the sysplex.
    - The GRS Mode field shows the GRS mode of the target system. The mode can be either STAR or RING.
    - The CMD column allows you to specify command codes. To use one of the command codes shown, type the appropriate letter next to the resource name, and press ENTER.
    - The System column shows the name of the system.
    - The Status column shows the status of the system.
    - The Monitor Timestamp column shows the last time stamp recorded for status monitoring on this system.
    - The INTERVAL column shows the system failure detection interval in seconds. This interval is the time XCF allows to elapse without a status update before assuming that the system failed.
- The last three columns contain configuration data of the SFM policy (if applicable).
- The SSUM Action field shows the SSUM action. It can be one of the following:

- ISOLATE
- DEACTIVATE
- RESET
- PROMPT
- N/A
- The SSUM TIME field shows the SSUM interval as specified in the current SFM policy.
- The SSUM WEIGHT field shows the SSUM weight specified in the current SFM policy. This value is used in sysplex reconfigurations after a signalling connectivity failure.

**CONsole**

**Purpose:** The CONSOLE function displays the following information for the target sysplex:

- The name of the master console
- WTO & WTOR buffer utilization
- Number of queued messages (replies) of various types
- Awaiting mounts
- Operator requests and list of consoles (name, status, authority, number of WTOR buffers, UD, device, system, ALTGRP, MSCOPE)

**Example:**

```

INGLX400                SA OS/390 - Command Dialogs                Line 1 of 6
Domain Id = IPSFP       ----- INGPLEX CONSOLE -----          Date = 04/12/01
Operator Id = NETOP1                                         Time = 10:36:26

Sysplex . . . . . : KEY1PLEX                Master Console . . . : --none--
Message Buffer Usage : 14 / 9999             Reply Buffer Usage . . : 14 / 99
Awaiting Replies . . : 14                   Eventual Action . . . : 0
Immediate Action . . : 0                     Awaiting Mounts . . . : 0
Critical Action . . . : 0                    Operator Requests . . . : 0
-----

Cmds: D Details / R Requests

  Console  Status  AUTH  NBUF  UD  Device  System  ALTGRP  MSCOPE
  -----  -
MASTER    INACTIVE MASTER n/a  Y  -none- --none-- --none-- *ALL
MASTER1   INACTIVE ALL    n/a  N  -none- --none-- --none-- *ALL
03         INACTIVE MASTER n/a  N  -none- --none-- --none-- *ALL
04         INACTIVE MASTER n/a  N  -none- --none-- --none-- *ALL
05         INACTIVE MASTER n/a  N  -none- --none-- --none-- *ALL
06         INACTIVE MASTER n/a  N  -none- --none-- --none-- *ALL

Command ==>
F1=Help      F2=End      F3=Return   F6=Ro11
              F9=Refresh  F12=Retrieve
    
```

Figure 80. INGPLEX CONS dialog panel

The following command codes are available:

**D** Displays details for the console

**R** Displays the actual requests for the console

- The **Sysplex** field shows the name of the sysplex.
- The **Message Buffer Usage** field shows the limit of the number of WTO message buffers allowed outstanding.

## INGPLEX CONSOLE

- The **Awaiting Replies** field shows a decimal number representing the number of messages awaiting replies.
- The **Immediate Action** field shows a decimal number representing the number of outstanding immediate action messages (with descriptor codes 1 or 2). If the number is greater than 99999, asterisks appear in this field.
- The **Critical Action** field shows a decimal number representing the number of outstanding critical eventual action messages (with descriptor code 11). If the number is greater than 99999, asterisks appear in this field.
- The **Master Console** field shows the name of the master console.
- The **Reply Buffer Usage** field shows the limit of the number of WTOR message buffers allowed outstanding. The maximum value of yyyy is specified by the RMAX parameter in the CONSOLxx parmlib member.
- The **Eventual Action** field shows a decimal number representing the number of outstanding eventual action messages (with descriptor code 3). If the number is greater than 99999, asterisks appear in this field.
- The **Awaiting Mounts** field shows a decimal number representing the number of outstanding mount requests.
- The **Operator Requests** field shows a decimal number representing the number of outstanding requests for operator intervention.
- The **CMD** column lets you specify the command codes shown on the panel. Enter the appropriate letter next to the resource name, and press ENTER.
- The **Console** column shows the name of the console as specified in the CONSOLxx parmlib member.
- The **Status** field shows the status of the console. The following values can occur:

**HARDCOPY** Hardcopy log. This condition is only indicated if the console is active on the system where the command processes.

**ACTIVE** Active console

**ACTIVE-P** In the process of becoming an active console. This condition is only indicated if the console is active on the system where the command is processing.

**MASTER** Master console

**INACTIVE** Inactive console

**INACT-P** In the process of becoming a non-active console. This condition is only indicated if the console is active on the system where the command is processing.

**PROB-DET** The active system console is in the problem determination mode. PD is indicated only for the system console.

**SUBSYS** Subsystem-allocatable console

- The **AUTH** column shows which commands may be entered from this console. The following values can occur:

**ALL** Any INFO, SYS, IO, or CONS command may be entered from this console.

**CONS** INFO commands and any commands from the console command group may be entered from this console.

**INFO** Any command from the informational command group may be entered from this console.

**IO** INFO commands and any commands from the I/O Control command group may be entered from this console.

**MASTER** The specified console is authorized to enter any operator command.

**NONE** This console has no command authority.

**SYS** INFO commands and any commands from the system control command group may be entered from this console.

- The **NBUF** column shows the number of WTO message buffers currently queued to this console. If nnnn is greater than 9999, asterisks (\*\*\*) appear in this field.
- The **UD** column shows whether this console is receiving messages with the UD attribute.
- The **Device** column shows the device number of the console as specified in the CONSOLxx parmlib member.
- The **System** column shows the system name of the active console.
- The **ALTGRP** column shows the alternate group defined for this console.
- The **MSCOPE** column lists the name of the system or systems from which this console is receiving unsolicited messages. Note that these systems might be different from the system where this console is physically attached.

## IPL

**Purpose:** With the INGPLEX IPL command you can view and compare the IPL information of the operating system. If a system does not behave after IPL as expected, the IPL recording function enables you to identify parameters that were changed, for example, since the last IPL. The recording function enables you to compare different IPL scenarios. INGPLEX IPL is a tool that helps to identify and resolve the cause of startup problems. The following information can be displayed:

- The selected system (or blank)
- The name of the sysplex
- The maximum number of IPLs that are stored for each system
- An indicator showing whether comments in PARMLIB members are ignored when collecting information

**Example:**

```

INGLX200          SA OS/390 - Command Dialogs          Line 1 of 6
Domain ID = IPSFM ----- INGPLEX IPL -----          Date = 02/22/02
Operator ID = NETOP1                                     Time = 17:59:27

System . . . . . ==>          Max. number of IPL records/system : 10
Sysplex . . . . . ==> KEY1PLEX  Suppression of PARMLIB comments . : N
-----
Cmds: C compare record / D display details / E erase record

  System  IPL Timestamp      Dev  Volume  OpSys  Release  FMID
-----
  KEYA    2002-02-22 13:52   770E 120204  z/OS   SP7.0.2  HBB7705
  KEYA    2002-02-09 09:28   770E 120204  z/OS   SP7.0.2  HBB7705
  KEYA    2002-02-08 15:28   770E 120204  z/OS   SP7.0.2  HBB7705
  KEYA    2001-12-10 14:31   0707 120147  z/OS   SP7.0.2  HBB7705
  KEYB    2002-02-22 13:59   770E 120204  z/OS   SP7.0.2  HBB7705
  KEYB    2002-02-14 16:24   770E 120204  z/OS   SP7.0.2  HBB7705
  KEYB    2002-02-11 18:46   770E 120204  z/OS   SP7.0.2  HBB7705
  KEYB    2002-02-11 15:36   770E 120204  z/OS   SP7.0.2  HBB7705
  KEYB    2002-02-11 14:22   770E 120204  z/OS   SP7.0.2  HBB7705

Command ==>
F1=Help          F2=End          F3=Return          F6=Ro11
                  F8=Forward      F9=Refresh        F10=Previous      F11=Next          F12=Retrieve
    
```

Figure 81. INGPLEX IPL main panel

Use F10 and F11 to scroll through all available columns. SORT by column numbers is supported as well as the FIND and RFind command to locate information on the panel. You can also limit the display to a particular system by specifying the system name in the appropriate entry field.

The following command codes are available:

- C** Compares the complete IPL information with another IPL record. A second panel will be displayed where you can select the second record.
- D** Displays detailed information about this IPL record.
- E** Erases the IPL information records. This action must be confirmed.
  - The **Sysplex** field shows the name of the sysplex.
  - The **System** field shows the name of the system in the sysplex.
  - The **IPL Timestamp** field shows the date and time of the IPL. The format is YYYY-MM-DD HH:MM converted to local timezone.
  - The **Dev** field shows the IPL device number.
  - The **Volume** field shows the volume serial of the IPL device.
  - The **OpSys** field shows the name of the operating system, for example, z/OS or OS/390.
  - The **Release** field shows the release level of the operating system.
  - The **FMID** field shows the FMID of the operating system.

For further information about the panel fields refer to the online help.

**SDUMP**

**Purpose:** The INGPLEX SDUMP command lets you control the default dump options sysplex-wide.

**Example:** The dump functions can be invoked directly by specifying the commands, or from the dump panel of the INGPLEX command selecting the appropriate command. In addition, you can invoke the dump submenu from the main panel of the INGPLEX command selecting command 7. The following panel is displayed:

```

INGLX250          SA OS/390 - Command Dialogs          Line 1 of 12
Domain Id = IPSFP  ----- INGPLEX -----             Date = 02/26/02
Operator Id = NETOP1                                Time = 16:30:36

Sysplex . . . . . : KEY1PLEX

Select the desired command:                          INGPLEX ...

  1 Control default SDUMP options                    SDUMP
  2 Issue SVC dumps                                  SVCDUMP
  3 Control SLIP trap settings                       SLIP

Command ==>
F1=Help      F2=End      F3=Return
F6=Ro11
F12=Retrieve
    
```

Figure 82. INGPLEX dump options panel

If you select option 1, the following panel is displayed:

```

INGLX251          SA OS/390 - Command Dialogs          Line 1 of 12
Domain Id = IPSFP  ----- INGPLEX SDUMP -----       Date = 02/26/02
Operator Id = NETOP1                                Time = 15:44:58

Sysplex . . . . . ==> KEY1PLEX          Permission . . . . . : ALL
-----
Cmds: C change

System  Dump options
-----
KEY1    Q=   Type=   Buffers= 0K MaxSpace= 500M MsgTime=99999
              TRT
              LSQA
KEY2    Q=   Type=   Buffers= 0K MaxSpace= 500M MsgTime=99999
              TRT
              LSQA
KEY3    Q=   Type=   Buffers= 0K MaxSpace= 500M MsgTime=99999
              TRT
              LSQA
KEY4    Q=   Type=   Buffers= 0K MaxSpace= 500M MsgTime=99999

Command ==>
F1=Help      F2=End      F3=Return      F6=Ro11
F8=Forward   F9=Refresh   F12=Retrieve
    
```

Figure 83. INGPLEX SDUMP panel

The following command code is available:

**C change**

Invokes the modification panel by providing the options of the selected system as input

## INGPLEX SDUMP

- The Sysplex field shows the name of the sysplex.
- The System field shows the name of the system in the sysplex.
- The Permission field shows your authorization level.
- The Dump options field shows the default SDUMP options of all systems in the sysplex. For each system the following details are displayed:

**Q=** Shows whether or not SDUMP quiesces the system while dumping the contents of the SQA or CSA.

**TYPE=**  
Causes SVC dump to dump the cross memory address spaces that the caller has when SVC dump gets control (XMEM) or when the error causing the dump occurs (XMEME).

**BUFFERS=**  
Shows the reserved storage exclusively used by SVC dump. This storage can be used while capturing the contents of the common area storage.

**MaxSpace**  
Shows the maximum amount of virtual storage that SVC dump can use to capture volatile virtual storage data, summary dump data, and component-specific data before writing the dump to DASD.

**MsgTime**  
Shows for which amount of time (mm) the message IEA793A is shown at the console. When the system deletes the message, it also deletes the captured dump.

The FIND and RFIND commands are supported. If you specify command code C, the following panel is displayed:

```

INGLX252                SA OS/390 - Command Dialogs                Line 1 of 12
Domain Id = IPSFP        ----- INGPLEX SDUMP -----            Date = 02/26/02
Operator Id = NETOP1                                          Time = 16:18:08

System . . . . . : KEY1
Sysplex . . . . . : KEY1PLEX                Recommended options are underlined.

NODUMP ... ==> N      (all other options below are ignored)

ALLNUC ... ==>      ALLPSA(*) ==>      COUPLE ... ==>      CSA ..... ==>
GRSQ ..... ==>      LPA ..... ==>      LSQA ..... ==> Y      NUC ..... ==>
PSA ..... ==>      RGN ..... ==>      SERVERS .. ==>      SQA(*) ... ==>
SUMSUMP(*) ==>      SWA ..... ==>      TRT ..... ==> Y      WLM ..... ==>
XESDATA .. ==>      (*) = The NOxxx option is generated when not selected.

Q(uiesce) ==>      (YES / NO)
Type ..... ==>      (XMEM / XMEME)
Buffers .. ==> 0K      (nnnnK / nnnM)
MaxSpace . ==> 500      (MB)
MsgTime .. ==> 99999      (minutes)

Command ==>
F1=Help      F2=End      F3=Return      F4=Set SYS      F5=Undo all      F6=Roll
F10=Set SYSS F11=Set SYSP F12=Retrieve

```

Figure 84. INGPLEX SDUMP modification panel

The modification panel allows to modify all SDUMP options. Furthermore, you can delete SDUMP options. After entering your changes you can set the new options for:

- The selected system
- All systems in the sysplex

- Selected systems in the sysplex

To set the options press the appropriate F-key. If you want to modify selected systems in the sysplex, you are prompted for the systems on which the SDUMP options are being changed. To reset the options to the state when the modification panel was invoked press F5 Undo all.

**Note:** The user must be authorized to change any SDUMP option. The authorization can be any of those which are used for controlling coupling facilities and couple data sets.

For further information about the panel fields refer to the online help.

## SVCdump

**Purpose:** The INGPLEX SVCDUMP function allows you to issue a multisystem dump of up to 15 address spaces of a single system including their data spaces and structures.

### Example:

```

INGLX26S                SA OS/390 - Command Dialogs                Line 1 of 6
Domain Id = IPSFP      ----- INGPLEX SVCDUMP -----            Date = 02/06/02
Operator Id = NETOP1                                       Time = 17:05:17

The following systems of sysplex KEY1PLEX are registered to the automation.
Use any non-blank character to select one system and then press ENTER.

      Sel  System
      ---  -----
      -    KEY2
      -    KEY3
      -    KEY4

Command ==>
      F1=Help      F2=End      F3=Return      F6=Ro11
                  F12=Retrieve

```

Figure 85. INGPLEX SVCDUMP target system selection panel

- The Sel field lets you select a system from which a multisystem dump is issued.
- The System field shows the name of the system having joined the same XCF group the operator is logged on to.

For further information about the panel fields refer to the online help. After selecting a system and pressing ENTER, the following panel is displayed:

## INGPLEX SVCdump

```

INGLX260          SA OS/390 - Command Dialogs          Line 38 of 63
Domain Id = IPXFG      ----- INGPLEX SVCDUMP -----      Date = 03/11/02
Operator Id = NETOP1                                     Time = 12:26:26

System . . . . . ==> KEYA
Sysplex . . . . . ==> KEYAPLEX
-----
Cmds: D/S de-/select job names for the SVC dump (up to 15 can be specified)

  Jobname      ASID  WorkUnitID  Userid
  -----
  _ TNF         0024
  _ TRACE      0004
  _ TSO        003B  STC05983   STCUSER
  _ VLF        0019
  _ VMCF       0025
  _ VTAM       001E  STC05982   STCUSER          selected
  _ WATS       0217  TSU06587   -                selected
  _ WLM        000B
  _ XCFAS      0006

Command ==>
F1=Help      F2=End      F3=Return      F5=NextPnl      F6=Roll
              F8=Forward   F9=Refresh

```

Figure 86. INGPLEX SVCDUMP address space selection panel

If you select VTAM address space and WATS address space, which is a user, press ENTER, then F5, the following panel is displayed:

```

INGLX261          SA OS/390 - Command Dialogs          Line 1 of 15
Domain Id = IPXFG      ----- INGPLEX SVCDUMP -----      Date = 03/11/02
Operator Id = NETOP1                                     Time = 12:34:04

System . . . . . : KEYA
Sysplex . . . . . : KEYAPLEX
-----
Cmds: D/S de-/select the areas to be dumped (max. 113 structures)
      A selection of the job name includes all related areas.

  Jobname  ASID  T Data Space/XCF Group Member/Structure
  -----
  _ VTAM   001E
  -       D ISTNMPDS
  -       D ISTNMSDS
  -       D IST08648
  -       D IST56892
  -       D IST69B2F
  -       D IST9BD36
  -       D IST90C95
  -       D 00012IXL
  -       D 00013IXL
  -       L ISTGENERIC          selected
  -       M ISTCFS01.KEYB.VTAM.IPXVH__DEIBMIPS  selected
  -       M ISTXCF.KEYB.VTAM.IPXVH__DEIBMIPS  selected
  -       M IXCLO008.KEYB.VTAM.M28          selected
  WATS    0217
Command ==>
F1=Help    F2=End      F3=Return   F4=PrevPnl  F5=NextPnl  F6=Roll
            F8=Forward   F9=Refresh

```

Figure 87. INGPLEX SVCDUMP address space detail panel

Address space VTAM has many dataspace (D), one list structure (L) and some XCF group members (M). TSO user WATS has nothing.

The following command codes are supported:

**D** Deselects the previous selection

- S** Selects a local address space, data space, structure, or XCF group member address space for the SVC dump.

If you press F5, the dump option selection panel is displayed:

```

INGLX262                SA OS/390 - Command Dialogs
Domain Id = IPSFP      ----- INGPLEX SVC -----
Operator Id = NETOP1                                     Date = 02/26/02
                                                         Time = 18:02:56

System . . . . . : KEY3
Sysplex . . . . . : KEY1PLEX

Title .... ==>
                ==>

SDATA Dump Options (recommended options are underlined)
ALLNUC ... ==>    ALLPSA(*) ==> Y    COUPLE ... ==>    CSA ..... ==> Y
GRSQ ..... ==> Y  LPA ..... ==>    LSQA ..... ==>    NUC ..... ==> Y
PSA ..... ==>    RGN ..... ==> Y    SERVERS .. ==>    SQA(*) ... ==> Y
SUMSUMP(*) ==> Y  SWA ..... ==>    TRT ..... ==> Y    WLM ..... ==>
XESDATA .. ==>    (*) = The NOxxx option is used when not selected.

Structure Dump Options (SUMMARY and ADJUNCT/ENTRYDATA are mutually exclusive)
COCLASS .. ==>    EMCONTROLS ==>    LISTNUM .. ==>    STGCLASS . ==>
ADJUNCT .. ==>    ENTRYDATA ==>    SUMMARY .. ==>

Command ==>
F1=Help    F2=End        F3=Return    F4=PrevPnl  F5=Dump        F6=Ro11
                                     F12=Retrieve

```

Figure 88. INGPLEX SVCDUMP dump option panel

The panel shows the default dump options being set on invocation. After specifying the dump title, press F5 to issue the dump. When the dump is taken, the function returns to the address space selection panel with all selections cleared. The SORT, FIND and RFIND commands are supported for selection panels only. For further information about the panel fields refer to the online help.

## SLIP

**Purpose:** With the INGPLEX SLIP command you can display serviceability level indication processing (SLIP) traps being set at all systems in the sysplex. With INGPLEX SLIP you can view, enable, disable, and delete the SLIP trap defined in the sysplex.

## INGPLEX SLIP

### Example:

```
INGLX270          SA OS/390 - Command Dialogs          Line 1 of 6
Domain Id = IPSFP  ----- INGPLEX SLIP -----          Date = 02/26/02
Operator Id = NETOP1                               Time = 18:20:21

System . . . . . ==>          (leave blank for all systems)
Slip Trap Id . . ==>          (leave blank for all ids)
Sysplex . . . . . ==> KEY1PLEX          Permission . . . . : ALL
-----
Cmds: +/- display/hide settings D disable E enable R remove

  System  Id    Status  Settings
-----
- KEY1    XB37  ENABLED
- KEY1    XD37  ENABLED
- KEY1    XE37  ENABLED
- KEY1    X0E7  ENABLED
- KEY1    X0F3  ENABLED
- KEY1    X013  ENABLED
- KEY1    X028  ENABLED
- KEY1    X13E  ENABLED

Command ==>
F1=Help          F2=End          F3=Return          F6=Roll
                  F8=Forward       F9=Refresh         F12=Retrieve
```

Figure 89. INGPLEX SLIP main panel

The following command codes are available:

- + Shows the settings of the SLIP trap.
- Hides the settings of the SLIP trap.
- D Disables the SLIP trap.
- E Enables the SLIP trap.
- R Deletes the SLIP trap.

The SORT, FIND and RFIND commands are supported.

**Note:** The user must be authorized to enable, disable, and delete a SLIP trap. The authorization can be any of those which are used for controlling coupling facilities and couple data sets.

For information about the panel fields refer to the online help.

## INGRELS

### Purpose

The INGRELS command shows the relationships that are defined for the given resource.

### Syntax

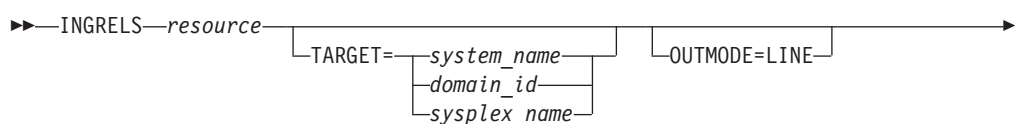

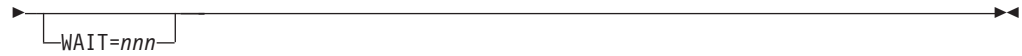

## Parameters

### *resource*

Specifies the name of the resource to be displayed. The format is *name/type[/system]*.

### TARGET

For information on the TARGET parameter, refer to “Additional Parameters for System Operations Commands” on page 10.

### OUTMODE

For information on the OUTMODE parameter, refer to “Additional Parameters for System Operations Commands” on page 10.

### WAIT

Specifies the number of seconds to wait before reporting that a timeout occurred if the automation manager does not provide the requested data. The maximum time interval is 999 seconds.

If omitted, the time interval is 30 seconds.

## Restrictions and Limitations

None.

## Usage

The INGRELS command operates sysplex-wide. For an overview refer to “Overview of Commands that Operate Sysplex-Wide” on page 9.

Automation manager commands are not supported on downlevel systems. Note that whenever an automation manager command is issued to a target system that is running an SA OS/390 Version lower than 2.1, the NetView error message DSI002I will not contain the name of the command that was issued but the name of the associated slave command.

## Examples

If you type `ingrels` and the name of a resource, a panel similar to the following is displayed.

## INGRELS

```
INGKYRL0          SA OS/390 - Command Dialogs      Line 1   of 14
Domain ID   = IPUFA   ----- INGRELS -----      Date = 07/03/00
Operator ID = NETOP1   Sysplex = AOCPLEX           Time = 14:04:51

Resource ==> HUGCF2APL4/APL/AOCB
System      ==>                System name, domain id or sysplex name

Name        Type System  Dir Relationship
-----
AOCB        SYG  AOCB    B  HasMember
           Cond: startDependency
           Cond: stopDependency
           Cond: extStart - UNSATISFIED
           Cond: extStop - UNSATISFIED
           Cond: extStopDelayed
           Cond: prestartDependency
           Cond: prestopDependency
           Cond: groupTriggerStartupInhibited - UNKNOWN
           Cond: groupTriggerShutdownInhibited - UNKNOWN
HUGCF2APL3  APL  AOCB    F  MakeAvailable/WhenAvailable

Command ==>
PF1=Help      PF2=End      PF3=Return   PF6=Ro11
              PF8=Forward  PF9=Refresh  PF12=Retrieve
```

Figure 90. INGRELS Command Dialog Panel

- The Name field shows the name of the resource that the specified resource has a relationship with. This is referred to as the relationship partner and is also called the supporting resource.
- The Type field shows the type of the resource.
- The System field shows the name of the system where the resource resides.
- The Dir field shows the direction of the relationships as seen from the specified resource.

**F** Forward. The relationship exists from the specified resource to the partner resource.

**B** Backward. The relationship exists from the partner resource to the specified resource.

- The Relationship field shows the name of the relationship that exists between the two resources. This defines the dependency that exists between the two resources. The status of all descendants will be considered for a relationship with strong chaining. For weak chaining only the direct descendants are checked. Weak is the default. Strong chaining causes SA OS/390 to check all relationships of the involved resources along the dependency graph.

If the relationship name contains 'active', this means that an attempt is made to bring the supporting resource in the required state to satisfy the dependency. Active is the default.

## INGREQ

### Purpose

The INGREQ command lets you:

- Initiate the shutdown process for a specific resource or group of resources
- Initiate the startup process for one or more resources

### Syntax

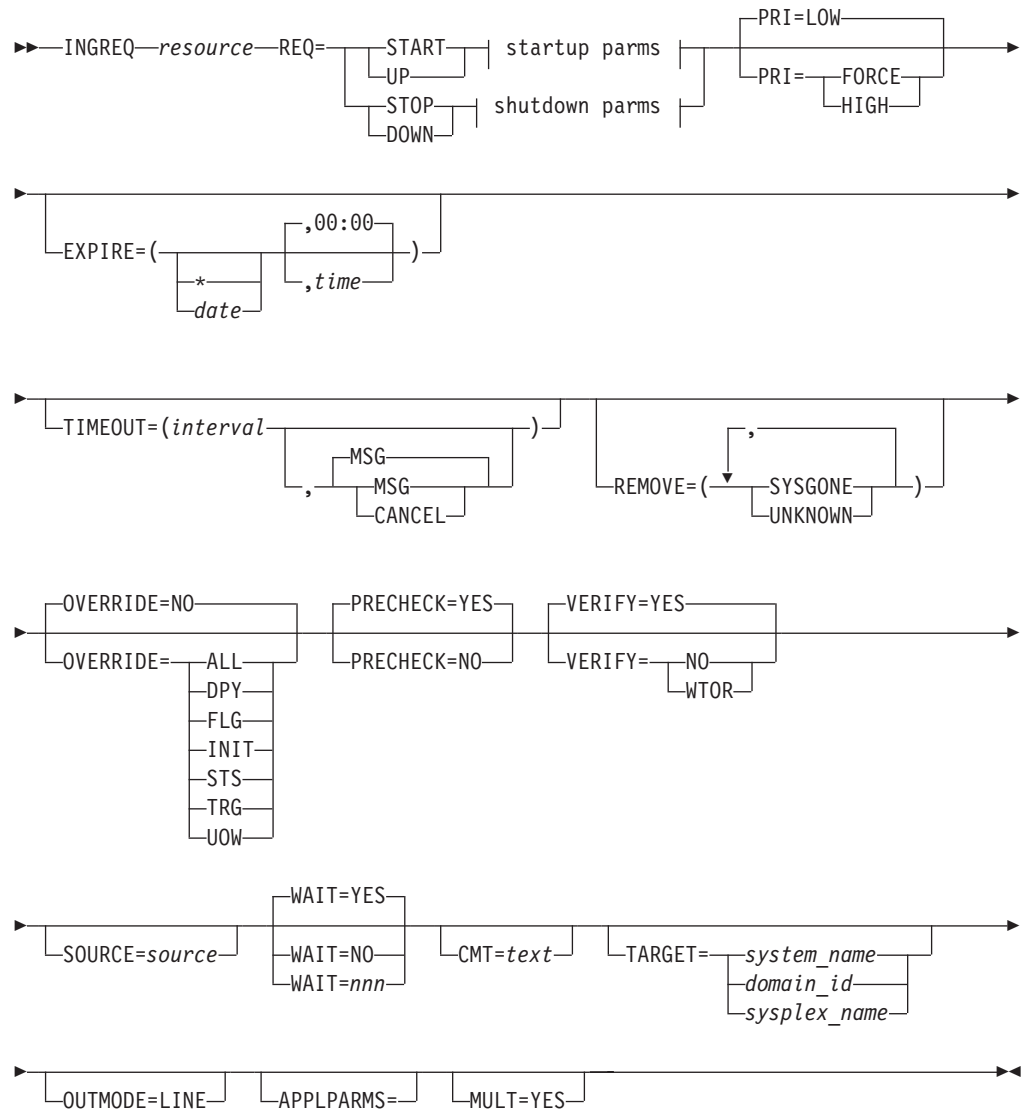

**Startup parms:**

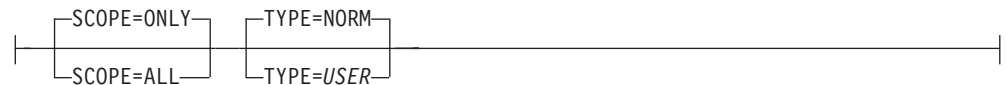

**Shutdown parms:**

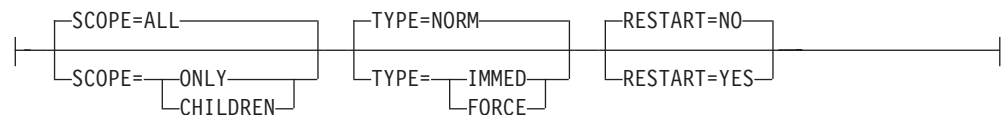

**Parameters**

**Resource**

Specifies the name of the resource to be processed. The format is *name[/type[/system]]*. Wildcards are supported. In full-screen mode, if more than

## INGREQ

one resource matches the wildcard specification, a selection panel will be displayed. In linemode, if more than one resource matches the wildcard specification and MULT=YES is specified, then all selected resources will be processed. Multiple resource specification in linemode without MULT=YES will cause an error message to be displayed.

**Note:** You need not specify the full name of the resource. This applies to the system as well as to the type. If the resource name is unique within the name space of the automation manager, then the system name need not be specified. If the resource name is unique within the appropriate types, then the type need not be specified. A valid resource name could be, for example, CICSPROD.

### REQ

Specifies the request to be carried out. It can be either START or STOP. Alternatively you can use UP respectively DOWN.

### PRI

Specifies the priority given to the request. It can be:

**FORCE** Takes precedence over requests posted with HIGH priority, for example, INGREQ=START PRI=FORCE overrides an INGREQ=STOP PRI=HIGH request.

**HIGH** High priority

**LOW** Low priority. This is the default.

### EXPIRE

Specifies the expiry date and time of the request. The request is automatically removed when it expires. The date format is yyyy-mm-dd. The time format is hh:mm.

### TIMEOUT

Specifies the interval used to check whether the request has been successfully completed. Either a message is issued, or the request is cancelled if the request has not been satisfied after that time. The format is mm.

### MSG

Specifies that a message should be issued telling the notify operator that the request was not satisfied within the expected time interval. The default is to issue a message.

### CANCEL

Specifies that the request should be cancelled.

### REMOVE

Indicates the condition under which the request is automatically removed, regardless of whether the request is satisfied or not. If the specified condition matches the observed status of the resource, the request will be deleted.

### SYSGONE

If the system where the automation agent runs leaves the sysplex, the observed status of all resources running on that system becomes SYSGONE.

### UNKNOWN

If the automation agent stops, the observed status of all resources controlled by the automation agent becomes UNKNOWN.

**OVERRIDE**

Specifies the overrides to be considered for the request. These can be one or more of the following:

**NO**

Specifies that no override is done. For example, a resource will not be started unless its startup flag is set on and its trigger, if used, is satisfied. This is the default.

**ALL**

Sets the DPY, FLG, INIT, STS, TRG, and UOW, flags on. For startup this means that the resource is made available regardless of the automation flag settings, its trigger setting or the state of the start dependencies defined for the resource. For shutdown this means that the resource is made unavailable regardless of its automation flag settings, the trigger state and the state of the stop dependencies.

**DPY**

Causes to ignore the status of the relevant START/STOP dependencies that are defined for the resource.

**Note:** This parameter should only be used with STOP SCOPE=ONLY.

**FLG**

The appropriate automation flags will be ignored for the resource.

**INIT**

The current INITIAL start required status will be ignored for a CICS subsystem. There are certain conditions when CICS abends and an INITIAL start is required. CICS Automation will detect these conditions and perform the next start with type INITIAL. This override can be used to ignore the INITIAL start tests, for example, if the problem has been fixed externally.

**STS**

The current observed status of the resource is ignored by the agent during INGREQ precheck processing. Override STS does not affect automation manager processing. Therefore, the automation manager may still reject the request after the agent forwarded the request to the automation manager.

**TRG**

The current trigger settings will be ignored when determining whether or not the resource can be started or stopped.

**UOW**

The current Outstanding Unit of Work status will be ignored for a CICS subsystem. If there are Outstanding Units of Work for a CICS subsystem, CICS Automation will start (based on user-specified policy) the subsystem with type AUTO. This override can be used to ignore the UOW tests.

**PRECHECK**

Specifies whether or not the startup/shutdown process should prevalidate any actions before actually performing them. The value can be:

**YES**

Validation is performed for the entry resources. This is the default.

**NO**

Validation is not performed before the command is issued.

**VERIFY**

Specifies whether the startup/shutdown process should be verified. The following specifications are valid:

**YES**

The list of affected resources is displayed before the startup/shutdown begins. The operator is prompted to verify the list.

## INGREQ

### WTOR

The list of affected resources is displayed before the startup/shutdown begins. The operator is prompted to verify the list via WTOR.

### NO

No verification is performed. VERIFY is set to NO for unattended tasks. Otherwise it is set to YES.

The default depends on the type of task that the INGREQ command runs on.

### SOURCE

Specifies the originator of the request. The default is OPERATOR for an OST and AUTOOPS for an autotask.

### WAIT

Specifies whether or not to wait until the request is complete. The default is YES.

*nmn* is the number of seconds to wait before giving up and reporting that a timeout has occurred. The maximum time interval is 999 seconds.

### CMT

Specifies descriptive information about the request. The maximum length is 120 characters. If the text contains embedded blanks, it must be enclosed in quotes or parentheses.

**Note:** Note that the comment is translated to uppercase.

### TARGET

For information on the TARGET parameter, refer to "Additional Parameters for System Operations Commands" on page 10.

### OUTMODE

For information on the OUTMODE parameter, refer to "Additional Parameters for System Operations Commands" on page 10.

### APPLPARMS

The content of APPLPARMS is put into the &EHKVAR1 variable. For further information refer to *System Automation for OS/390 User's Guide*.

### MULT

Specifies that more than one resource will be accepted when running in linemode, if the resource wildcard specification results in multiple resources.

### SCOPE

Specifies whether the startup/shutdown affects a resource and/or its descendants. Valid options are:

#### ONLY

Specifies that only the specified resource is started or stopped. This is the default for startup.

#### ALL

Specifies that the resource and its descendants are started or stopped. This is the default for shutdown.

#### CHILDREN (shutdown only)

Specifies that only the descendants of the resource are stopped.

### TYPE

Specifies the type of the startup/shutdown. Each type must be defined in the policy database. Valid options are:

**NORM (startup/shutdown)**

Specifies a normal startup/shutdown. This is the default.

**IMMED (shutdown only)**

Specifies an immediate shutdown.

**FORCE (shutdown only)**

Specifies a forced shutdown.

**USER (startup only)**

Specifies a user-defined startup type.

**Note:**

The value specified here will be overridden by the INGSET STARTTYPE/STOPTYPE value if previously specified. However, a stop type of FORCE, wherever specified will always be honored.

Use the VERIFY option to view the TYPE value that will be used for this request.

**RESTART (shutdown only)**

Specifies whether the resource should be restarted automatically when it has been shutdown completely. Valid options are:

**NO**

Specifies that no restart is performed. This is the default.

**YES**

Specifies that a restart is performed.

**Restrictions and Limitations**

To use the INGREQ command system operations must be initialized.

**Usage**

The INGREQ command operates sysplex-wide. For an overview refer to "Overview of Commands that Operate Sysplex-Wide" on page 9.

Automation manager commands are not supported on downlevel systems. Note that whenever an automation manager command is issued to a target system that is running an SA OS/390 Version lower than 2.1, the NetView error message DSI002I will not contain the name of the command that was issued but the name of the associated slave command.

**Examples**

If you type INGREQ a panel similar to the following is displayed:

```

INGKYRU0          SA OS/390 - Command Dialogs
Domain ID = IPSFO  ----- INGREQ -----      Date = 06/27/02
Operator ID = NETOP1                               Time = 18:37:59

Resource =>                                     format: name/type/system
System   =>                                     System name, domain ID or sysplex name

Request  =>                                     Request type (START, UP or STOP, DOWN)
Type     => NORM                               Type of processing (NORM/IMMED/FORCE/user) or ?
Scope    =>                                     Request scope (ONLY/CHILDREN/ALL)
Priority  => LOW                               Priority of request (FORCE/HIGH/LOW)
Expire   =>                                     , Expiration date(yyyy-mm-dd), time(hh:mm)
Timeout  => 0 / MSG                            Interval in minutes / Option (MSG/CANCEL)
AutoRemove =>                                     Remove when (SYSGONE, UNKNOWN)
Restart  => NO                                 Restart resource after shutdown (YES/NO)
Override => NO                                 (ALL/NO/TRG/FLG/DPY/STS/UOW/INIT)
Verify   => YES                               Check affected resources (YES/NO/WTOR)
Precheck => YES                               Precheck for flags and passes (YES/NO)
Appl Parm =>

AOF710A VERIFY/REVISE INPUT AND THEN PRESS ENTER
Command ==>>
PF1=Help    PF2=End    PF3=Return    PF6=Roll
PF11=Next   PF12=Retrieve
    
```

Figure 91. INGREQ Command Dialog Panel 1

- The Resource field shows the name of the resource to be processed. The format is *name/type[/system]*. Wildcard is supported.
- The System field shows the name of the system (system name, domain ID, or sysplex name) to which the command should be routed. Specifying this is only necessary if the resources are not part of the local sysplex.
- The Request field shows the request to be carried out. This is either START or STOP. Alternatively you can use UP, respectively DOWN.
- The Type field shows the type of the startup/shutdown. Valid shutdown types are NORM, IMMED and FORCE as well as any other type defined in the Policy database for the resource. Specify a question mark (?) to display the list of defined startup types.
- The Scope field shows whether the startup/shutdown affects this resource and/or its descendants.
- The Priority field shows the priority given to the request.
- The Expire field shows the expiry date and time when the request will be removed.
- The Timeout field shows the time within which the request must complete. After this time interval either a message is issued, or the request is cancelled.
- The AutoRemove field shows the condition under which the request is automatically removed regardless of whether the request is satisfied or not.
- The Restart field shows whether the resource should be restarted automatically when it has been shutdown completely. This applies only when requesting a shutdown of a resource.
- The Override field shows the overrides to be considered for the request. The parameter can be used to bypass the conditions/settings that would otherwise prevent a resource(s) from starting or shutting down.
- The Verify field shows whether the startup/shutdown process should be verified. If YES or WTOR is entered, the list of affected resources is displayed before the startup/shutdown begins. You will be prompted to verify the list. IF WTOR is specified, you will be prompted via a WTOR. If NO is entered, the startup/shutdown begins immediately. The default is YES.

- The Precheck field shows whether or not the startup/shutdown process should perform upfront validation.
- The Appl Parm's field shows modifications or parameters to the START or STOP request.

If you press PF11 a panel similar to the following is displayed:

```

INGKYRU2          SA OS/390 - Command Dialogs          Page 2 of 2
Domain ID = IPSFP ----- INGREQ -----          Date = 06/28/02
Operator ID = NETOP1                                Time = 15:30:25

Resource =>                                         format: name/type/system
System   =>          System name, domain ID or sysplex name
Comment  =>

Command ==>
PF1=Help   PF2=End   PF3=Return   PF6=Ro11
PF10=Previous PF12=Retrieve
    
```

Figure 92. INGREQ Command Dialog Panel 2

- The Comment field lets you specify descriptive information, for example, why the request was made.

## INGRPT

### Purpose

The INGRPT command displays statistical information about the automation agent and some basic information about the automation manager. Two types of reports are produced:

- Summary report
- Detail report

### Syntax

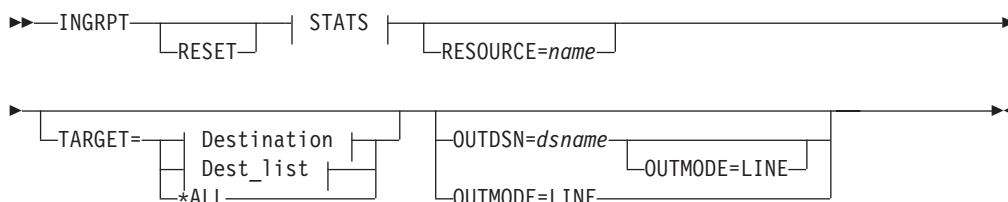

## INGRPT

### Report options::



### Destination:



### Dest\_list:



## Parameters

The following parameters are supported:

### RESET

Resets the counters to 0. This option can be specified with the STATS parameter to get the statistics information and subsequently reset the counters.

### RESOURCE

Is the name of the subsystem for you want to collect the statistics, for example, TSO. Wildcard is supported, for example, INGRPT STATS=D RESOURCE=abc\*. The wildcard can be leading or trailing, for example \*abc\*.

### TARGET

For information on the TARGET parameter, refer to “Additional Parameters for System Operations Commands” on page 10.

### OUTMODE

For information on the OUTMODE parameter, refer to “Additional Parameters for System Operations Commands” on page 10.

### OUTDSN

For information on the OUTDSN parameter, refer to “Additional Parameters for System Operations Commands” on page 10.

### STATS

Specifies whether to generate a summary report or a detail report. Detail statistics include information about each resource or subsystem that is automated by the agent. The following options are valid:

#### SUMMARY

This is the default.

#### DETAIL

Specifies to show detailed information for each resource (subsystem in the automation agent terminology).

#### NONE

No report is produced. The NONE option is only useful if the reset option is specified.

### Restrictions and Limitations

None.

### Usage

Note that INGRPT is not supported on system lower than SA OS/390 2.2. Whenever an automation manager command is issued to a target system that is lower than SA OS/390 2.2, the NetView error messages DSI002I does not contain the name of the command that was issued but the name of the according slave command.

Issuing ACF COLD resets the statistic counters.

The statistic counters for a subsystem removed with INGAMS REFRESH are not erased. However, the statistic counters for a subsystem are cleared if ACF COLD or INGRPT RESET is issued.

## INGSCHED

### Purpose

INGSCHED displays a list of all defined schedules (service periods). It lets you:

- Update the time slots (this is referred to as schedule override)
- Display the list of resources that are associated with the schedule
- Delete schedule or resource overrides

### Syntax

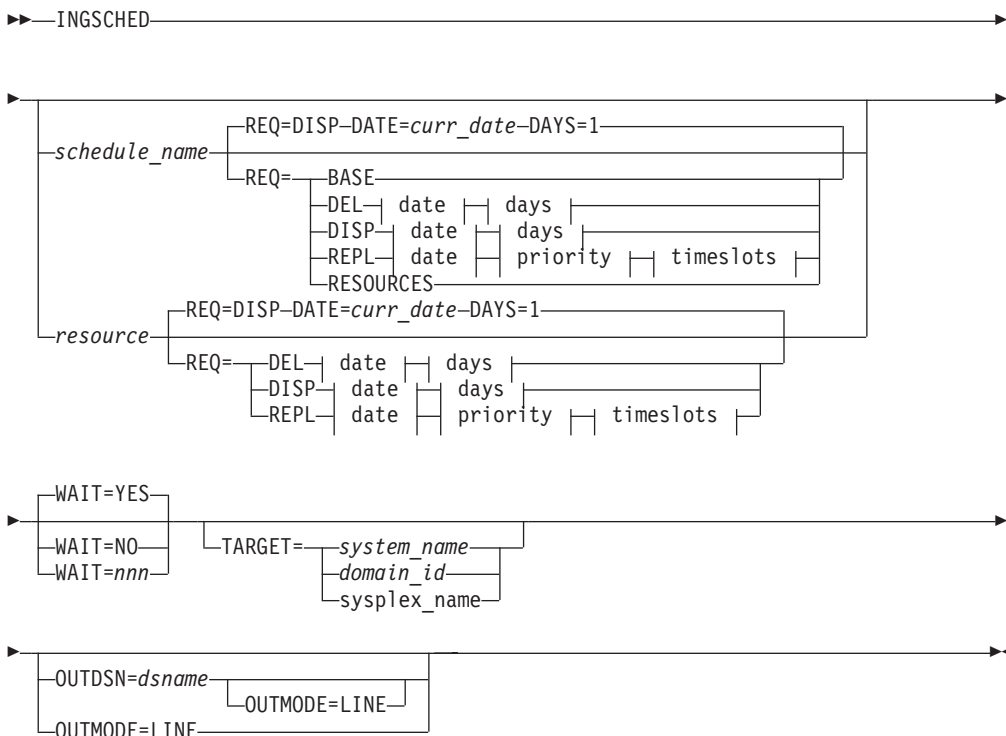

**date:**

## INGSCHED



### days:

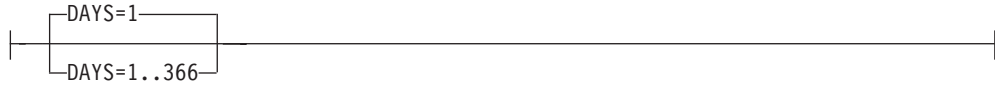

### priority:



### timeslots:

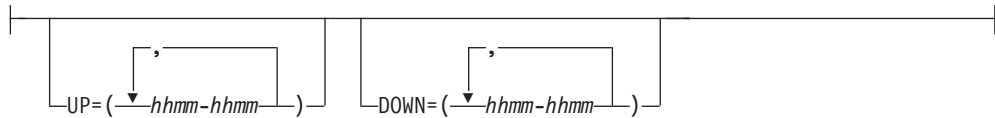

## Parameters

### *schedule\_name*

Is the name of the schedule to be displayed.

### *resource*

Specifies the resource for which the schedule overrides are to be displayed.  
The format is *name/type[/system]*

### REQ

Specifies the request. The request can be:

#### **BASE**

Displays the base schedule information.

#### **DEL**

Deletes the overrides for the specified date.

#### **DISP**

Displays the base schedule, schedule override or resource overrides starting with the specified date.

#### **REPL**

Replaces the schedule or resource override with a new one.

#### **RESOURCES**

Displays the resources that use the specified schedule (service period).

### DATE

Specifies the date in *yyyymmdd* format for which the delete or replace of the override should be done.

### DAYS

Specifies the number of days for which the overrides should be displayed or deleted.

**PRIORITY**

Specifies the priority to be assigned to the override. The first value is the UP priority and the second value is the DOWN priority. Valid values are:

**HIGH**            High priority  
**LOW**             Low priority

Both priorities are optional. The default is LOW. The priority values can be abbreviated.

**UP**

Specifies the UP start and stop times in the format *hhmm-hhmm*. Up to five time slots can be specified separated by a comma. The UP time slots define the time windows where the resource must or should be available. A priority of HIGH means that the resource must be available, while a priority of LOW means that the resource should be available.

**DOWN**

Specifies the DOWN start and stop times. The format is *hhmm-hhmm*. Up to five time slots can be specified separated by a comma. The DOWN time slots define the time window where the resource must/should be **Not** available (= unavailable). A priority of HIGH means that the resource must be unavailable, while a priority of LOW means that the resource should be unavailable. If you specify DOWN, specifying the UP priority becomes mandatory.

**WAIT**

Specifies whether or not to wait until the request is complete. The default is YES.

*nnn* is the number of seconds to wait before giving up and reporting that a timeout has occurred. The maximum time interval is 999 seconds.

**TARGET**

For information on the TARGET parameter, refer to "Additional Parameters for System Operations Commands" on page 10.

**OUTMODE**

For information on the OUTMODE parameter, refer to "Additional Parameters for System Operations Commands" on page 10.

**OUTDSN**

For information on the OUTDSN parameter, refer to "Additional Parameters for System Operations Commands" on page 10.

**Restrictions and Limitations**

The INGSCHED command can only be used when system operations is initialized.

Service period overrides cannot be modified immediately after a system time change where the system clock was set back, for example, in case of daylight savings. Overrides cannot be modified until the new local time passes the original pre-adjustment local time.

**Usage**

The INGSCHED command operates sysplex-wide. For an overview refer to "Overview of Commands that Operate Sysplex-Wide" on page 9.

Automation manager commands are not supported on downlevel systems. Note that whenever an automation manager command is issued to a target system that is running an SA OS/390 Version lower than 2.1, the NetView error message DSI002I will not contain the name of the command that was issued but the name of the associated slave command.

## INGSCHEd

The automation agent as well as the automation manager verify each time slot being modified. Due to the delay between these verifications, a time slot of the current day that is still valid when the agent checks it, could be already invalid when the automation manager checks it. For example, the agent passes an override request to the manager at 10:59:59. The automation manager scheduler receives the request at 11:00:01 and rejects it because the starttime has already elapsed. This is indicated by return code 8 and reason code X'10C4' in message INGY1004. If this error occurs, you can fix it by correcting the time slot in error and reissuing the override.

### Examples

The following panel is displayed:

```
INGKYSPO          SA OS/390 - Command Dialogs      Line 1 of 3
Domain ID = IPSNM ----- INGSCHED -----      Date = 05/05/99
Operator ID = WAS                                     Time = 19:56:24

Cmd:  A Show Details  B Show Overrides  C Show Resources

Cmd Schedule  Description
-----
_  STD_SERV   Standard Service Period
_  TSOPLUS   Special service period for TSOPLUS
_  ONLINE    Schedule for CICS applications

Command ==>
PF1=Help      PF2=End      PF3=Return    PF6=Roll
               PF8=Forward  PF9=Refresh   PF12=Retrieve
```

Figure 93. INGSCHED Command Dialog Panel 1

- The CMD field allows you to specify command codes. To use one of the command codes shown, type the appropriate letter next to the resource name and press Enter. The following command codes are available:
  - A** Show Details. Displays the service periods for the selected schedule without any override.
  - B** Show Overrides. Displays the overrides for the selected schedule starting with the current day for the next n days filling one panel.
  - C** Show Resources. Displays the list of resources/application groups that make use of the schedule. This can then be used to modify the service periods for the resource.
- The Schedule field shows the schedule (service period) defined in the sysplex.
- The Description field shows the description specified for the resource.

### Showing Schedule Details

Overrides are shown in white.

The base time slots for a selected schedule are displayed when specifying command code A in front of the schedule. The following panel is displayed (note that INGSCHED REQUEST=BASE shows a similar panel):

```

INGKYSPI          SA 0S/390 - Command Dialogs          Line 1  of 14
Domain ID = IPSFO ----- INGSCHED -----          Date = 10/25/99
Operator ID = NETOP1          Sysplex = KEY1PLEX          Time = 14:36:07

Schedule. . : SHIFT1          Weekday A.M. (06:00 - 11:59)

  Day    Pri  Strt/Stop  Strt/Stop  Strt/Stop  Strt/Stop  Strt/Stop
  ---    --  - - - - -  - - - - -  - - - - -  - - - - -  - - - - -
MON  UP   H   0600-1159  _____  _____  _____  _____
    DN   H   0000-0559  1200-2400  _____  _____  _____
TUE  UP   H   0600-1159  _____  _____  _____  _____
    DN   H   0000-0559  1200-2400  _____  _____  _____
WED  UP   H   0600-1159  _____  _____  _____  _____
    DN   H   0000-0559  1200-2400  _____  _____  _____
THU  UP   H   0600-1159  _____  _____  _____  _____
    DN   H   0000-0559  1200-2400  _____  _____  _____
FRI  UP   H   0600-1159  _____  _____  _____  _____
    DN   H   0000-0559  1200-2400  _____  _____  _____
SAT  UP   L   _____  _____  _____  _____  _____
    DN   H   0000-2400  _____  _____  _____  _____
SUN  UP   L   _____  _____  _____  _____  _____
    DN   H   0000-2400  _____  _____  _____  _____

Command ==>
PF1=Help      PF2=End          PF3=Return    PF6=Ro11
                PF9=Refresh          PF12=Retrieve
  
```

Figure 94. INGSCHED Command Dialog Panel 2

- The Schedule field shows the name of the schedule as defined in the sysplex.
- The Day field shows the day of the week.
- The Pri field shows the priority associated with the day of the week. It can have the following values:
  - H** High priority. The resource must be down/up.
  - L** Low priority. The resource should be down/up.
- The Strt/Stop field shows the begin and end times of the service window.

### Showing Schedule Overrides

To display detailed information for a particular schedule, specify command code B in front of the schedule. The panel displayed then shows the start/stop times starting from the requested date. The default is starting from the current day. For each day, two rows are displayed.

- The first row (UP) shows the time slots when the associated resources should be up (available).
- The second row (DN) shows the time slots when the associated resources should be down (unavailable).

To modify the start/stop times for the various days, overtype them. Start/stop times that have been overwritten are shown in yellow. The overrides for a particular day can be removed with command code D, except for time slots that are affected by the current time. The time slots will then be restored to the original values.

# INGSCHED

```
INGKYSP2          SA OS/390 - Command Dialogs
Domain ID   = IPSFO   ----- INGSCHED -----   Date = 10/25/99
Operator ID = AFRANCK   Sysplex = KEY1PLEX       Time = 14:53:15

Schedule . . . : SHIFT1      Weekday A.M. (06:00 - 11:59)
Starting date => 10 / 25 / 1999 (mm/dd/yyyy)

C Date          Pri  Strt/Stop  Strt/Stop  Strt/Stop  Strt/Stop  Strt/Stop
-----
10/25/99 Mon UP  H  0600 1159
                   DN  H  0000 0559 1200 2400
10/26/99 Tue UP  H  0600 1159
                   DN  H  0000 0559 1200 2400
10/27/99 Wed UP  H  0600 1159
                   DN  H  0000 0559 1200 2400
10/28/99 Thu UP  H  0600 1159
                   DN  H  0000 0559 1200 2400
10/29/99 Fri UP  H  0600 1159
                   DN  H  0000 0559 1200 2400
10/30/99 Sat UP  L
                   DN  H  0000 2400
10/31/99 Sun UP  L
                   DN  H  0000 2400
11/01/99 Mon UP  H  0600 1159
                   DN  H  0000 0559 1200 2400
11/02/99 Tue UP  H  0600 1159
                   DN  H  0000 0559 1200 2400

Command ==>
PF1=Help      PF2=End      PF3=Return    PF6=Roll
PF7=Backward  PF8=Forward   PF9=Refresh   PF12=Retrieve
```

Figure 95. INGSCHED Command Dialog Panel 3

To delete individual overrides, blank out the appropriate time slot.

### Showing Resources Related to a Schedule

A list of resources that use the selected schedule is displayed when specifying command code C in front of the schedule. A panel similar to the following is displayed.

```

INGKYS P3          SA OS/390 - Command Dialogs      Line 1   of 6
Domain ID = IPSFO  ----- INGSCHED -----        Date = 10/25/99
Operator ID = NETOP1      Sysplex = KEY1PLEX      Time = 14:57:29

Schedule. . : SHIFT1          Weekday A.M. (06:00 - 11:59)

Cmd: S Show Overrides
Cmd Resource      Type System      Description
-----
MSCSUBSYS        APL  KEY3      test application
MSCSUBSYS        APL  KEY4      test application
STDT001AA00     APL  KEY1      A. M. shift (6:00 - 11:59)
STDT001AA00     APL  KEY2      A. M. shift (6:00 - 11:59)
STDT001AA00     APL  KEY3      A. M. shift (6:00 - 11:59)
STDT001AA00     APL  KEY4      A. M. shift (6:00 - 11:59)

Command ==>
PF1=Help      PF2=End      PF3=Return      PF6=Ro11
               PF9=Refresh      PF12=Retrieve
    
```

Figure 96. INGSCHED Command Dialog Panel 4

- The Cmd field allows you to display specific information for each system. The following command code is available:
  - S** Shows overrides. Changes service periods for the resource group.
- The Resource field shows the name of the resource that uses the specified schedule.
- The Type field shows the type of the resource.
- The System field shows the name of the system that the resource resides on.
- The Description field shows the description specified for the resource.

The FIND/RFIND subcommands are supported. Refer to “Deciding the Format of the Command Output (Full-Screen only)” on page 13 for information.

### Showing Resource Overrides

The following panel shows schedule overrides:

```

INGKYS P2          SA OS/390 - Command Dialogs
Domain ID   = IPUFA   ----- INGSCHED -----   Date = 07/04/00
Operator ID = NETOP1   Sysplex = AOCPLEX           Time = 14:56:08

Resource . . . : STDT005AA00/APL/AOCA           Schedule . . . : SHIFT5
Starting date => 07 / 04 / 2000   (mm/dd/yyyy)

C Date          Pri  Strt/Stop  Strt/Stop  Strt/Stop  Strt/Stop  Strt/Stop
-----
07/04/00 Tue UP  L
                DN  H   0000 1900
07/05/00 Wed UP  L   1600 1800
                DN  H   1800 1900
07/06/00 Thu UP  L
                DN  H   0000 1900
07/07/00 Fri UP  L
                DN  H   0000 1900
07/08/00 Sat UP  L
                DN  H   0000 1900

A0F099I FUNCTION SUCCESSFULLY COMPLETED
Command ==>
PF1=Help      PF2=End      PF3=Return    PF6=Roll
PF7=Backward  PF8=Forward  PF9=Refresh   PF12=Retrieve
    
```

Figure 97. INGSCHED Command Dialog Panel 5

The panel shows the service windows currently defined for the resource. The service windows are determined as follows:

- Base service periods from the associated schedule, if any are defined
- Override service periods from the associated schedule, if any are defined
- Override service periods associated with the resource
- The Day field shows the day of the week.
- The Pri field shows the priority associated with the day of the week. It can have the following values:
  - H** High priority.
  - L** Low priority.
- The Strt/Stop fields show the begin and end times of the service window. For each day, two rows are displayed.
  - The first row (UP) shows the time slots when the associated resources must be up (available).
  - The second row (DN) shows the time slots where the associated resources must be down (unavailable).

Time slots that are overrides for the resource are shown in pink. Time slots defined for the base schedule are shown in green, while its overrides are shown in yellow. Time slots that are already passed cannot be deleted or overridden. To set an override, type over the appropriate time field.

## INGSEND Using RMTCMD

### Purpose

INGSEND routes commands to other domains using NetView RMTCMD.

INGSEND can use either gateways or NetView RMTCMD to send commands. See “INGSEND Using Gateway Sessions” on page 175 for information about INGSSEND using gateways.

Use the target parameter with the system operations commands if possible.

### Syntax

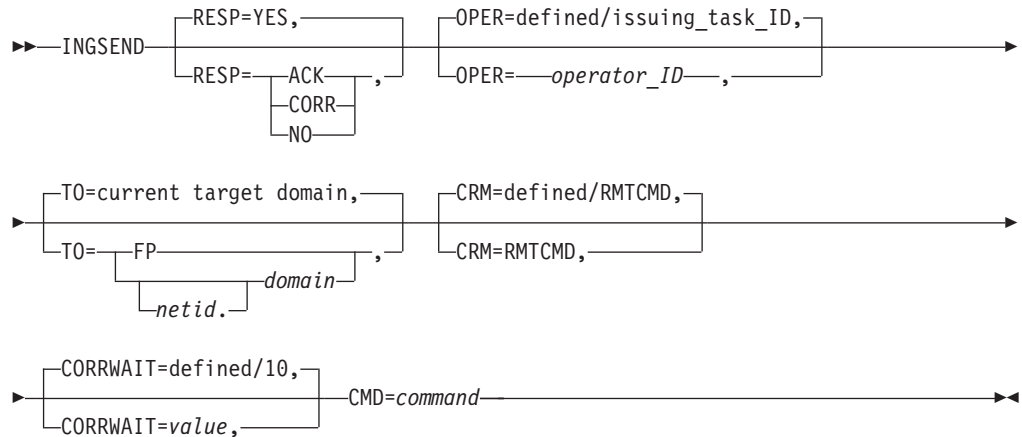

### Parameters

#### RESP

Specifies whether you want to receive an asynchronous response or acknowledgement when you issue the command. Valid options are:

#### ACK

If you use this option:

- A message is displayed on the operator's NCCF console stating whether or not the command executed successfully
- If the command executed successfully, message AOF672I will be displayed
- If the command executed but failed, message AOF671I will be displayed
- If the command could not be delivered to the target domain or RMTCMD autotask, or was delivered and failed to begin execution, the appropriate NetView RMTCMD message will be displayed to explain the failure.

#### NO

Specifies that you do not want to receive any output from the command.

#### YES

Specifies that you want the output from the command displayed on your NCCF console.

#### CORR

Specifies that you want the output from the command to be correlated back to the INGSSEND RESPONSE DISPLAY panel. See *Restrictions* on correlating command output.

#### OPER

Specifies the operator upon which to issue the command.

*operator\_ID* can be defined using the customization dialog for each domain. If not defined, it will default to the issuing task ID.

#### Notes:

1. If operator alias GATOPER or BASEOPER is specified, the operator ID will default to the issuing task id.

## INGSEND Using RMTCMD

2. If the orig.operid = target.operid in the OPER keyword, the command *will* be issued.

### TO

Specifies the domain to which the command is being issued.

*[netid].domain*

Specifies the domain to which the command is being issued. It can be defined using the customization dialog. Netid is optional.

**FP** Specifies that the command is to be routed to the current focal point.

### Notes:

1. When INGSEND is issued on the current focal point, and TO=FP is specified, the command *will* be issued.
2. If this parameter (TO=...) is omitted, the current target domain (that is, the last domain you sent a command to) is used, if one is set. If none, error message AOF102I will be issued.

### CRM

Specifies that the command routing mechanism to be used is the NetView RMTCMD command.

A default command routing mechanism can be predefined for each target system using the customization dialog. Refer to *System Automation for OS/390 User's Guide* for further information. If you do not predefine a command routing mechanism in this way, it will default to RMTCMD.

### CORRWAIT

Specifies the CORRWAIT value (in seconds) to be used when INGSEND uses NetView PIPES. The Corrwait PIPE stage is necessary to trap asynchronous command output. A default for this value can be predefined for each target system, using the customization dialog. If not predefined, the default is 10 seconds. For more information on the use of this value, see discussion of the PIPE command in *NetView Operation*.

### CMD

Specifies the command to be executed. The length of the command can be up to 213 characters.

## Restrictions and Limitations

- The INGSEND command will not execute under the primary POI task (PPT).
- INGSEND uses the NetView PIPE command to trap the message output from the routed command. Not all commands are PIPE enabled, which means that the command may not be treated as requested in the RESP keyword. Some examples of commands that are not PIPE enabled are:
  - MVS commands on a NetView not exploiting EMCS
  - Commands that produce full screen output
  - A NetView command that is not PIPE enabled

For more information on RMTCMD and PIPE commands, see *NetView Operation*.

## Usage

If the command you are issuing contains either a space, a comma, or a delimiter, you should delimit the command.

You can delimit the command you are sending with either single quotation marks, double quotation marks, or '/'. If you wish to include an occurrence of the delimiter character within the delimited string, then the character must be

preceded by another delimiter character. The delimiter character must appear as the first character of the string after the 'CMD='. INGSEND sends the command defined by the start and end delimiter. Examples of INGSEND with commands that do use delimiters are included below.

### Examples

```
"INGSEND RESP=ACK,TO=CNM01,CMD=START TASK=DSILOG"
```

Command START TASK=DSILOG will be routed with the following:

Keyword	Value	Reason
TO	CNM01	Specified
RESP	ACK	Specified
OPER	OPER4	Predefined
CRM	RMTCMD	Default

The following message will be issued to OPER2' NCCF console:

```
"AOF672I COMMAND (START TASK=DSILOG) WAS EXECUTED IN DOMAIN CNM01 BY A
RMTCMD COMMAND FROM OPERATOR OPER2"
```

OPER4 is defined using the customization dialog. The above example does not use delimiters.

The following example does not use delimiters as far as INGSEND is concerned even though there are delimiter characters in it.

```
INGSEND RESP=ACK,TO=CNM01,CMD=MVS $D'RMF'
```

The following is correctly delimited.

```
INGSEND RESP=ACK,TO=CNM01,CMD='ACT CHP123'
```

The following example is also correctly delimited and contains the delimiter character within the delimiters. This command is equivalent to the second example.

```
INGSEND RESP=ACK,TO=CNM01,CMD='MVS $D'RMF'
```

The following example is also correctly delimited and is an alternative way to type the previous example.

```
INGSEND RESP=ACK,TO=CNM01,CMD=/MVS $D'RMF' /
```

The following example will be passed as correctly delimited but only 'MVS \$D' will be sent as the end delimiter follows the "D" thus defining the command.

```
INGSEND RESP=ACK,TO=CNM01,CMD='MVS $D'RMF' "
```

## INGSEND Using Gateway Sessions

### Purpose

INGSEND routes commands to other domains using gateway sessions.

INGSEND can use either gateways or NetView RMTCMD to send commands. See "INGSEND Using RMTCMD" on page 172 for information about INGSEND using RMTCMD.

Use the target parameter with the system operations commands if possible.

## INGSEND Using Gateway Sessions

### Syntax

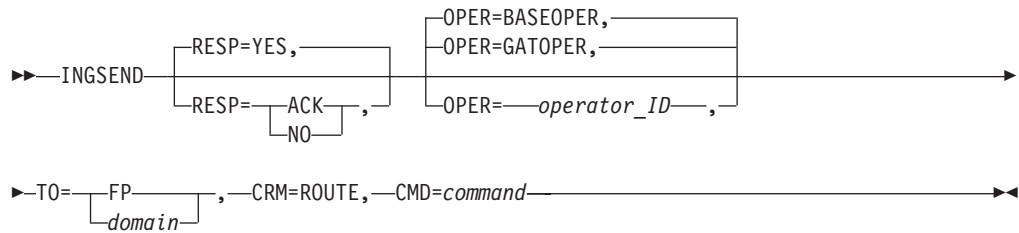

**Note:** Default GATOPER applies for directly connected domains. Default BASEOPER applies for indirectly connected domains.

### Parameters

#### RESP

Specifies whether you want to receive an asynchronous response or acknowledgement when you issue the command.

#### ACK

If you use this option:

- A message is displayed on the operator's NCCF console stating whether or not the command executed successfully
- If the command executed successfully, message AOF672I will be displayed
- If the command executed but failed, message AOF671I will be displayed

#### NO

Specifies that you do not want either a response or an acknowledgement.

#### YES

Specifies that you want the output from the command displayed on your NCCF console. This is the default.

#### OPER

Specifies the operator that issues this command. Do not specify the PPT.

#### GATOPER

Specifies the GATOPER operator on the target system. This is the default for a directly connected domain. This gives the fastest response.

#### BASEOPER

Specifies the BASEOPER operator on the target system. This is the default for an indirectly connected domain.

#### operator\_ID

Specifies a particular operator ID. You can specify any SA OS/390 automation operator or human operator ID.

#### TO

Specifies the system to which the command is being issued.

#### domain

Specifies the system to which the command is being issued.

**FP** Specifies that the command is to be routed to the current automation focal point.

## INGSEND Using Gateway Sessions

**Note:** When INGSEND is issued on the current focal point, and TO=FP is specified, the command is **NOT** issued.

### CRM=ROUTE

Specifies that the command routing mechanism to be used is the NetView ROUTE command.

A default command routing mechanism can be defined using the customization dialog. If you do not predefine a command routing mechanism in this way, it will default to RMTCMD.

### CMD

Specifies the command to be executed on target system.

## Restrictions and Limitations

Do not issue the NetView LOGOFF command. Do not issue commands that require a confirmation at the target system, for example INGREQ VERIFY=YES. For more information on commands that you can and cannot send to another system, refer to *NetView Customization: Writing Command Lists*.

## Usage

You can enclose the command you are sending in either single or double quotation marks, or / (slash).

You can delimit the command you are sending with either single quotation marks, double quotation marks, or /. If you wish to include an occurrence of the delimiter character within the delimited string, then the character must be preceded by another delimiter character. The delimiter character must appear as the first character of the string after the 'CMD='. INGSEND sends the command defined by the start and end delimiter. Examples of INGSEND with commands that do use delimiters are included below.

**Note:** Before you send a command, check the status of the gateway session to the target system using the Operator Interface. Refer to *System Automation for OS/390 User's Guide* for further information.

## Examples

```
"INGSEND TO=CNM01,CRM=ROUTE,CMD=D NET,APPLS"
```

Command D NET,APPLS will be routed with the following:

Keyword	Value	Reason
TO	CNM01	Specified
RESP	YES	Default
CRM	ROUTE	Specified
OPERID	GATOPER	Default for ROUTE

The above example does not use delimiters.

The following example does not use delimiters as far as INGSEND is concerned even though there are delimiter characters in it.

```
INGSEND RESP=ACK,TO=CNM01,CRM=ROUTE,CMD=MVS $D'RMF'
```

The following is correctly delimited.

```
INGSEND RESP=ACK,TO=CNM01,CRM=ROUTE,CMD='ACT CHP123'
```

## INGSEND Using Gateway Sessions

The following example is also correctly delimited and contains the delimiter character within the delimiters. This command is equivalent to the second example.

```
INGSEND RESP=ACK,CRM=ROUTE,TO=CNM01,CMD='MVS $D'RMF'
```

The following example is also correctly delimited and is an alternative way to type the previous example.

```
INGSEND RESP=ACK,CRM=ROUTE,TO=CNM01,CMD=/MVS $D'RMF'/
```

The following example will be passed as correctly delimited but only 'MVS \$D' will be sent as the end delimiter follows the "D" thus defining the command.

```
INGSEND RESP=ACK,TO=CNM01,CRM=ROUTE,CMD='MVS $D'RMF' "
```

## INGSET

### Purpose

INGSET is a line mode command that is primarily used in automation clists. With the INGSET command you can:

- Remove an operator's request
- Set a status attribute or automation flag for a resource or application group
- Clear or set the hold flag for a resource or application group
- Set or reset the Group failed flag
- Set the start or stop type for a resource

### Syntax

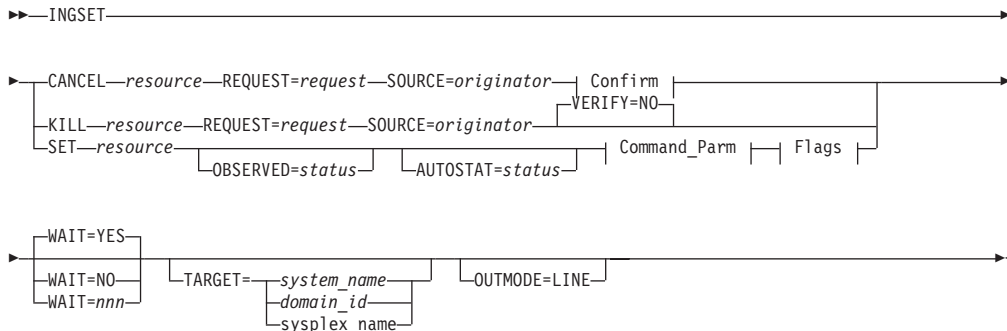

### Confirm:



### Command\_Parm:

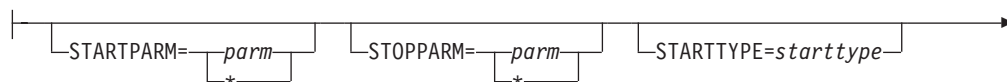

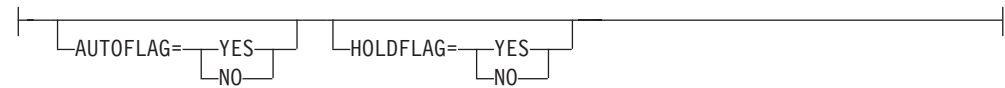
**Flags:****Parameters****CANCEL**

Removes a request.

*resource*

Specifies the resource for which the request is to be cancelled. The format is *name/type/system*. Wildcard is supported.

**KILL**

Removes a request without verifying. To perform verification specify the VERIFY parameter.

*resource*

Specifies the resource for which the request is to be killed. The format is *name/type/system*. Wildcard is supported.

**SET**

Sets one or more resource attributes. The following settings can be made:

- Observed status
- Automation status
- Automation flags
- Hold flag
- Group failed flag
- Start type for next startup
- Stop type for next shutdown

Wildcard is supported for the SET parameter.

*resource*

Specifies the resource for which an attribute is to be set. The format is *name/type/system*. Wildcard is supported.

**REQUEST**

Causes the request to be canceled. You can specify one of the following:

- MAKEAVAILABLE
- MAKEAVAILABLESO
- MAKEUNAVAILABLE
- MAKEUNAVAILABLESC
- MAKEUNAVAILABLESO

Wildcard is supported, for example, REQUEST=MAKEUN\*

**SOURCE**

Specifies the source of the request, for example OPERATOR, or AUTOOPS. Wildcard is supported, for example, SOURCE=\*

## INGSET

### OBSERVED

Specifies the observed status to be assigned to the resource. The status can be abbreviated, for example, to AV for available.

### AUTOSTAT

Specifies the automation status to be assigned to the resource. The status can be abbreviated, for example, to ID for idle.

### WAIT

Specifies whether or not to wait until the request is complete. The default is YES.

*mm* is the number of seconds to wait before giving up and reporting that a timeout has occurred. The maximum time interval is 999 seconds.

### VERIFY

Specifies whether cancelling the request is to be verified. The following specifications are valid:

**YES** The list of affected resources is displayed before the request is removed. The operator is prompted to verify the list.

**NO** No verification is performed. VERIFY is set to NO for AUTOTASKs. Otherwise it is set to YES.

### WTOR

The list of affected resources is displayed before the request is removed. The operator is prompted to verify the list via WTOR.

The default depends on the type of task that the INGREQ command runs on.

### TARGET

For information on the TARGET parameter, refer to "Additional Parameters for System Operations Commands" on page 10.

### OUTMODE

For information on the OUTMODE parameter, refer to "Additional Parameters for System Operations Commands" on page 10.

### STARTPARM

Is the START parameter that is passed to the command.

### STOPPARM

Is the STOP parameter that is passed to the command.

### STARTTYPE

Specifies the type of command to be issued for the resource's next startup. The value specified here is used only once and takes precedence over the TYPE value specified on the next INGREQ (REQ=START) command.

### STOPTYPE

Specifies the type of command to be issued for the resource's next shutdown. The value specified here is used only once and takes precedence over the TYPE value specified on the next INGREQ (REQ=STOP) command. However, a stop type of FORCE, wherever specified, will always be honored.

### AUTOFLAG

Specifies the automation flag. It can be either YES or NO. It can be abbreviated.

### HOLDFLAG

Specifies whether the resource is to be started. It can be either YES or NO. The

HOLD flag can only be set if the resource is down, that is if its observed status is either HardDown, SoftDown, SysGone or Unknown.

**Return Codes**

The following return codes can occur:

- 0 The request was processed successfully.
- 1 An error occurred while processing the request.
- 4 Exit requested.

**Usage**

Note that if you cancel a verification process of a list of affected resources, SA OS/390 may issue a slightly misleading message. Although the verification is cancelled, message AOF099I FUNCTION COMPLETED may be returned.

**Examples**

To cancel a previously issued request to make a resource available, type the following:

```
INGSET CANCEL TSO/APL/KEY1 REQUEST=AVAILABLE SOURCE=OPERATOR
```

To set the starttype for the next startup of a JES2 resource to COLD, type the following:

```
INGSET SET JES2/APL/KEY1 STARTTYPE=COLD
```

**INGTHRES**

**Purpose**

The INGTHRES command displays all thresholds defined for a resource. INGTHRES lists the thresholds that were set using the INGTHRES command or that are defined in your automation control file. INGTHRES also lets you set, change or delete the threshold settings for a particular resource. INGTHRES also sets the defaults for all MVS subcomponents, for all subsystems, or for MVSESA components.

**Syntax**

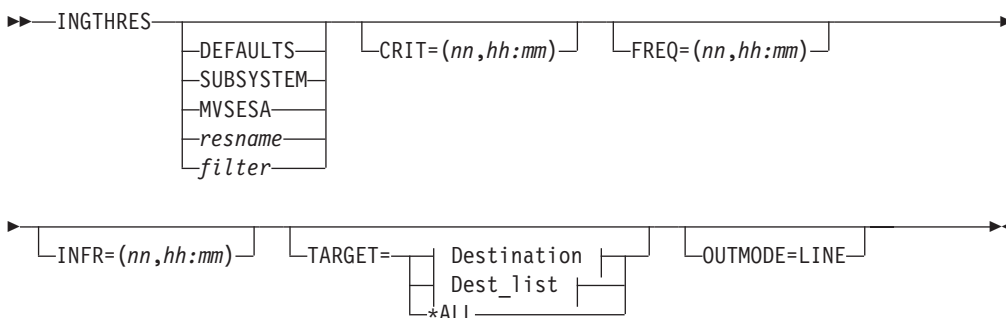

**Destination:**



## INGTHRES

### Dest\_list:



### Parameters

If you do not specify a subsystem, the INGTHRES panel is displayed.

#### DEFAULTS

Sets the default settings for all automated resources. All automated resources that do not have their own threshold settings or that do not belong to a group that has its own settings use these defaults.

#### SUBSYSTEM

Sets defaults for all subsystems.

#### MVSESA

Sets defaults for all MVS subcomponents.

#### *resname*

Specifies a particular resource, for example, WTOBUF. You can specify any automated resource.

#### *filter*

Is the filter used for the output. Only resource names that match the filter criteria are displayed. Wildcard is supported. The filter consists of the major resource name and, optionally, of a minor resource name separated by a dot, for example, CICS\*.TRANS\*, or \*.CEMT. To view major resources specify \*. To view minor resources specify xyz:\*. Note that this parameter is not supported for systems running SA OS/390 Versions lower than 2.1.

#### CRIT

Specifies values for the critical threshold.

*nn* Specifies the number of errors before the threshold is reached. You can specify a maximum of 10.

#### *hh:mm*

Specifies the time span before the threshold is reached: hh = hours, mm = minutes.

#### FREQ

Specifies values for the frequent threshold.

*nn* Specifies the number of errors before the threshold is reached. You can specify a maximum of 10.

#### *hh:mm*

Specifies the time span before the threshold is reached: hh = hours, mm = minutes.

#### INFR

Specifies values for the infrequent threshold.

**nn** Specifies the number of errors before the threshold is reached. You can specify a maximum of 10.

#### **hh:mm**

Specifies the time span before the threshold is reached: hh = hours, mm = minutes.

**TARGET**

For information on the TARGET parameter, refer to “Additional Parameters for System Operations Commands” on page 10.

**OUTMODE**

For information on the OUTMODE parameter, refer to “Additional Parameters for System Operations Commands” on page 10.

**Restrictions and Limitations**

The changes you make are active only until the next time the automation control file is loaded.

The INGTHRES command can only be used when SA OS/390 is initialized.

**Usage**

SA OS/390 uses threshold settings to determine when to stop trying to recover a component or restart a subsystem. The primary use of thresholds is to track subsystem abends and to make sure that the abend and recovery cycle does not become a loop.

When a threshold is crossed, SA OS/390 performs the action specified for that threshold in the automation control file. For components, this action is customer-defined—ask your SA OS/390 administrator. For subsystems, the following actions occur:

Threshold exceeded	What SA OS/390 does
Infrequent	Issues warning message
Frequent	Issues warning message
Critical	Stops Restart automation and issues a message to that effect

All three threshold values (CRIT, FREQ, and INFR) can be set with one invocation of the command.

The Critical threshold should specify more errors or a shorter time than the Frequent and Infrequent thresholds.

**Examples**

To set defaults for all automated resources, type:

```
ingthres defaults crit=(2,00:14) freq=(2,01:00) infr=(4,04:00)
```

To add or replace the critical threshold for the resource JES2, type:

```
ingthres jes2 crit=(2,02:00)
```

If you type `ingthres jes2`, you see the following command dialog:

```

INGKYTH0          SA OS/390 - Command Dialogs          Line 1 of 4
Domain ID = IPSFM ----- INGTHRES -----          Date = 12/07/01
Operator ID = NETOP1                                Time = 14:25:05

Cmd:  A Add thresholds   C Change thresholds   D Delete thresholds

Cmd  System  Resource          Critical      Frequent      Infrequent
-----
KEY1  DEFAULTS
KEY1  MVSESA          1 in 01:00    1 in 02:00    1 in 04:00
KEY1  SUBSYSTEM        1 in 00:05    1 in 00:30    1 in 01:00
KEY1  JES2              1 in 01:00    1 in 04:00    1 in 08:00

Command ==>>
PF1=Help    PF2=End        PF3=Return    PF6=Roll
PF9=Refresh                                PF12=Retrieve
  
```

Figure 98. Display of Threshold Settings for JES (INGTHRES JES)

If JES reaches the Critical threshold, Restart automation does not continue. If JES exceeds the Frequent or Infrequent threshold, a message is sent to notification operators to inform them.

- The CMD field lets you modify the thresholds of a resource. The following command codes are supported:
  - A** Add new thresholds for a resource with the same values as the one selected
  - C** Change existing thresholds for a selected resource
  - D** Delete threshold settings for a selected resource

To define thresholds for a resource you can either type the ADD command in the command line or specify command code A in front of the resource whose thresholds should be used as default. You can then modify the settings as needed.

- The System field shows the name of the system where the resource resides.
- The Resource field shows the name of the resource for which the thresholds are defined. The entries are sorted alphabetically.
- The Critical field shows the critical threshold defined for the resource.
- The Frequent field shows the frequent threshold defined for the resource.
- The Infrequent field shows the infrequent threshold defined for the resource. The format of the thresholds is *nn in hh:mm*. This means that the threshold is exceeded if more than *nn* errors occur within *hh* hours and *mm* minutes.

If you specify command code A, a panel similar to the following is displayed:

```

AOFKAASR          SA OS/390 - Command Dialogs
Domain ID = IPSFM  ----- INGTHRES -----   Date = 12/07/01
Operator ID = NETOP1                               Time = 16:30:54

Specify thresholds and resource changes:

Resource  =>
System    =>  KEY1          Group or specific resource
                        System name, domain ID, sysplex name or *all

Critical  =>  1  errors in 01:00   Time (HH:MM)
Frequent  =>  1  errors in 02:00   Time (HH:MM)
Infrequent =>  1  errors in 04:00   Time (HH:MM)

Pressing ENTER will set the THRESHOLD values

Command ==>
PF1=Help   PF2=End   PF3=Return
PF6=Roll   PF12=Retrieve
    
```

Figure 99. INGTHRES sample panel

## INGTIMER

### Purpose

The INGTIMER command links NetView timer commands to subsystems. This means that the timer is only active when the subsystem is active. When the subsystem terminates, the timer commands are automatically purged. To de-activate the timers at SHUTINIT time, the INGTIMER subsystem PURGE command can be specified as a SHUTINIT command.

### Syntax

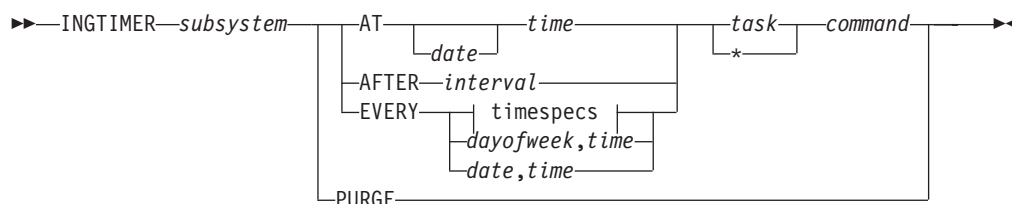

### timespecs:

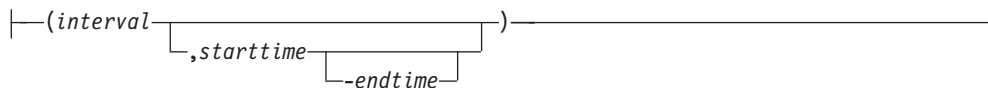

### Parameters

#### subsystem

Specifies the name of the subsystem.

#### AT

Specifies the starttime of the command.

#### AFTER

Specifies the time interval that must elapse after the subsystem became active.

## INGTIMER

When this time interval has elapsed, the command is run. For example, if the subsystem becomes active at 12:00 am and you specify 2 hours, the command runs at 2:00 pm.

### EVERY

Specifies the times when the command is to be repeated between the 'starttime' and 'endtime'.

### PURGE

Specifies that all timers associated with the subsystem are purged.

### *date*

Specifies the date, in mm/dd/yy format, on which the command should run. The date can begin with one or more Xs.

### *time*

Specifies the time at which the command is to run. The format is hh[:mm[:ss]]. Instead of entering digits, one or more Xs can be specified at the beginning. If the time begins with an X or multiple Xs instead of a number, the command is set to begin at the next increment of time.

### *interval*

Specifies the time interval that is to elapse before the command is run. The format is hh[:mm[:ss]]. Minutes and seconds are optional values.

### *starttime*

Specifies the start time of the command which is when it is to be run for the first time. The format is hh[:mm[:ss]]. Minutes and seconds are optional values. The specified time can be earlier than the current time. The command is then run at the next regular interval after the current time, with intervals calculated based on the start time. If the time begins with an X or multiple Xs instead of a number, the command is set to begin at the next time increment.

### *endtime*

Specifies the time when the interval is to end. The format is hh[:mm[:ss]]. Minutes and seconds are optional values. Applies only when the interval is shorter than 24 hours.

### *Dayofweek*

Specifies the day of the week when the timer command should run. Specify MON, TUE, ..., SUN, or WEEKDAY or WEEKEND.

### *Date*

Is the date, in mm/dd/yy format, on which the command should run. The date can begin with one or more Xs.

### *task*

Specifies the operator from whose user ID the command is to be executed. It can also be an automated function. The default is the workoperator associated with the subsystem. The timer itself runs on the PPT task.

- \* Is a placeholder which indicates that the default is used. The default is the workoperator associated with the subsystem.

### *command*

Specifies which command is to be issued when the timer expires.

All timers are converted to the NetView CHRON command format. Thus, daylight saving time switching is supported. The timer runs on the PPT task.

**Note:** Storing the timer in the NetView save/restore database is pointless because the timer is only active while the subsystem is in an UP state.

## Restrictions and Limitations

None.

## Usage

To link a timer to a subsystem, the user has to register the NetView timer command as follows:

- At subsystem poststart time. This associates the timer command with the subsystem and activates the timer.
- Whenever NetView is restarted. This activates the timer command again.

The timers are only in effect when the subsystem for which they are defined is active. This is useful for applications that can be moved within the sysplex.

## Examples

To issue a command that should run every 30 minutes between 10:00 am and 2:00 pm, specify the following:

```
INGTIMER TSO EVERY (00:30,10:00-14:00) * F MVS &SUBSJOB,GETLSEQ
```

To issue a command that should run 10 minutes after a certain subsystem became available, specify the following:

```
INGTIMER &SUBSAPPL AFTER 00:10 * BROADCAST Subsystem is now active
```

To issue a command that should run each Friday at 5:00 pm, specify the following:

```
INGTIMER &SUBSAPPL EVERY FRI,17:00 PPT MVS D T
```

## INGTOPO

### Purpose

The INGTOPO command collects SA OS/390 topology information from target systems and maintains structures of objects within RODM that correspond to it.

### Syntax

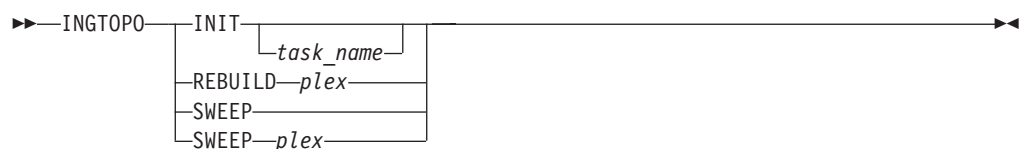

### Parameters

#### INIT

In INIT mode, INGTOPO builds or updates the SA OS/390 objects in RODM in accordance with the automation managers of all sysplexes defined in the INGTOPOF file. INIT is the mode which you must specify at the very first task of INGTOPO. In this case, you must also specify the name of the task under which the Topology Manager runs.

You can call INGTOPO with INIT any time. INGTOPO then either rebuilds the SA OS/390 objects from scratch or just performs the necessary update operations. In the former case all event-based minor resources, for example, WTORS, that existed in RODM will be lost, since these minor resources do not exist within the automation manager and therefore cannot be built.

If you want to know about the result of your INGTOPO INIT request, look into message ING063I and check the return code that it contains.

## INGTOPO

*task\_name*

Specifies the autotask that is used for status collection on the focal-point system.

*plex*

Specifies the sysplex.

### REBUILD

In REBUILD mode, INGTOPO removes all SA OS/390 objects in RODM for the specified sysplex and rebuilds them from scratch. Note that after calling INGTOPO with REBUILD, all event-based minor resources, for example, WTORs, that existed in RODM for this sysplex will be lost, since these minor resources do not exist within the automation manager and therefore cannot be built.

### SWEEP

All SA OS/390 topology manager objects in RODM are erased and all internal information is reset.

### Restrictions and Limitations

To run the INGTOPO command the Multisystem Manager (MSM) must be active.

### Usage

The INGTOPO command should be issued from the NetView that provides status updates to NMC.

## INGTRIG

### Purpose

INGTRIG shows all triggers that are defined and used by resources within the sysplex.

### Syntax

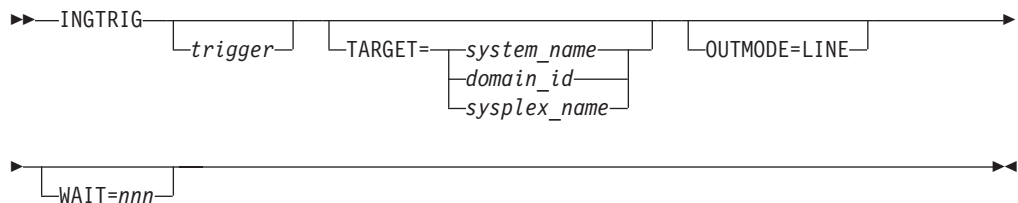

### Parameters

*trigger*

Specifies the name of the trigger for which the resource using the trigger should be displayed.

### TARGET

For information on the TARGET parameter, refer to “Additional Parameters for System Operations Commands” on page 10.

### OUTMODE

For information on the OUTMODE parameter, refer to “Additional Parameters for System Operations Commands” on page 10.

### WAIT

Specifies the number of seconds to wait before reporting that a timeout occurred if the automation manager does not provide the requested data. The maximum time interval is 999 seconds.

If omitted, the time interval is 30 seconds.

## Restrictions and Limitations

Triggers of down-level systems cannot be shown.

## Usage

The INGTRIG command operates sysplex-wide. For an overview refer to “Overview of Commands that Operate Sysplex-Wide” on page 9.

Automation manager commands are not supported on downlevel systems. Note that whenever an automation manager command is issued to a target system that is running an SA OS/390 Version lower than 2.1, the NetView error message DSI002I will not contain the name of the command that was issued but the name of the associated slave command.

## Examples

If you type ingtrig a panel similar to the following is displayed.

```

INGKYTR0                SA OS/390 - Command Dialogs          Line 1   of 10
Domain ID = IPSFP      ----- INGTRIG -----             Date = 10/26/99
Operator ID = NETOP1   Sysplex = KEY1PLEX                 Time = 10:55:16

Cmd: S show associated resources

Cmd Trigger  Description
-----
BATCHSTP    Batch jobs B000P100,P200,P300
BATCHSTR    Batch jobs B000S100,S200,S300
MDOTRGI3    Trigger3
MDOTRIG1    Trigger1
MDOTRIG2    Trigger2
MSCTRG1     scheduling test trigger 1
MSCTRG2     scheduling test trigger 2
TRIGGER6    Hourly window + batch controlled events
TRIGGER7    Command controlled events, No UNSET
TRIGGER8    Command controlled events, diff. unsets

Command ==>
PF1=Help    PF2=End      PF3=Return   PF6=Ro11
              PF9=Refresh  PF12=Retrieve

```

Figure 100. INGTRIG Command Dialog Panel 1

This panel shows all triggers that are defined within the scope of the automation manager.

- The CMD field allows you to display specific information for each system. The following command code is available:

**S** Show associated resources. Displays all resources that use the trigger.

- The Trigger field shows the name of the trigger.
- The Description field is self-explanatory.

## INGTRIG

The FIND/RFIND and SORT subcommands are supported. Refer to “Deciding the Format of the Command Output (Full-Screen only)” on page 13 for information.

### Showing Resources

Specify command code S in front of a trigger, or ingtrig triggername to display all resources that are associated with that selected trigger:

```
INGKYTR1          SA OS/390 - Command Dialogs      Line 1   of 4
Domain ID  = IPSFP  ----- INGTRIG -----      Date = 10/26/99
Operator ID = AFRANCK      Sysplex = KEY1PLEX      Time = 11:16:54

Trigger . . : TRIGGER6      Hourly window + batch controlled events

Cmd: S show trigger details
Cmd Resource      Type System      Description
-----
TRGG006AA10     APL KEY1
TRGG006AA10     APL KEY2
TRGG006AA10     APL KEY3
TRGG006AA10     APL KEY4

Command ==>
PF1=Help      PF2=End      PF3=Return      PF6=Roll
              PF9=Refresh      PF12=Retrieve
```

Figure 101. INGTRIG Command Dialog Panel 2

- The Cmd field allows you to specify command codes to display specific information for the trigger. The following command code is available:
  - S Show trigger details. Initiates the DISPTRG command dialog for the selected resource.
- The Resource field shows the name of the resource.
- The Type field shows the type of the resource.
- The System field shows the name of the system where the resource resides.
- The Description field shows the description specified for the resource.

The FIND/RFIND and SORT subcommands are supported. Refer to “Deciding the Format of the Command Output (Full-Screen only)” on page 13 for information.

## INGVOTE

### Purpose

The INGVOTE command displays:

- All pending requests that were entered from the automation manager
- All pending votes of a specified resource

### Syntax

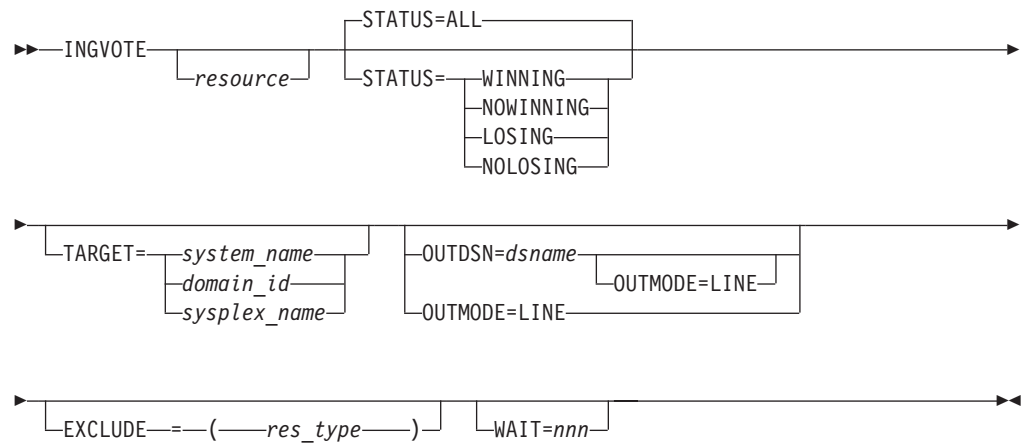

## Parameters

### *resource*

Specifies the resource to be displayed. The format is *name/type[/system]*. Wildcard is supported.

### STATUS

Specifies whether to display the winning or losing requests or votes only. The default is ALL. The STATUS parameter can have the following values:

**WINNING** Displays the winning requests or votes.

**NOWINNING** Displays the losing requests or votes.

**LOSING** Displays the losing requests or votes.

**NOLOSING** Displays the winning requests or votes only.

**ALL** Displays all winning and losing requests or votes. This is the default.

The values can be abbreviated.

### TARGET

For information on the TARGET parameter, refer to “Additional Parameters for System Operations Commands” on page 10.

### OUTMODE

For information on the OUTMODE parameter, refer to “Additional Parameters for System Operations Commands” on page 10.

### OUTDSN

For information on the OUTDSN parameter, refer to “Additional Parameters for System Operations Commands” on page 10.

### EXCLUDE

Specifies the resource type to be excluded from the display. More than one value can be specified. For example INGVOTE EXCLUDE=SVP causes all service period resources to be filtered out from the display. Specify NO or \* to reset the installation-provided default.

### WAIT

## INGVOTE

Specifies the number of seconds to wait before reporting that a timeout occurred if the automation manager does not provide the requested data. The maximum time interval is 999 seconds.

If omitted, the time interval is 30 seconds.

### Restrictions and Limitations

None.

### Usage

The INGVOTE command operates sysplex-wide. For an overview refer to “Overview of Commands that Operate Sysplex-Wide” on page 9.

Automation manager commands are not supported on downlevel systems. Note that whenever an automation manager command is issued to a target system that is running an SA OS/390 Version lower than 2.1, the NetView error message DSI002I will not contain the name of the command that was issued but the name of the associated slave command.

### Examples

If you type ingvote a panel similar to the following is displayed:

```
INGKYRQ2                SA OS/390 - Command Dialogs                Line 1 of 72
Domain ID = IPUFA      ----- INGVOTE -----                Date = 07/04/00
Operator ID = NETOP1   Sysplex = AOCPLEX                Time = 15:42:32

Cmd: C Cancel request  K Kill request    S Show details    V Show votes
Cmd Name      Type System      Request Data
-----
BNKNACHT     SVP              Req : MakeUnAvailable
              Org : SCHEDULE
              Pri : 01120000  Should Be Down - Schedule
              Stat: Winning/Unsatisfied
BZOMSCMV     SVP              Req : MakeAvailable_Only
              Org : SCHEDULE
              Pri : 02140000  Must Be Up - Schedule
              Stat: Winning/Unsatisfied
HOURLY       SVP              Req : MakeAvailable_Only
              Org : SCHEDULE
              Pri : 02140000  Must Be Up - Schedule
              Stat: Winning/Unsatisfied
HUGDAY       SVP              Req : MakeAvailable_Only

Command ==>
PF1=Help      PF2=End          PF3=Return       PF6=Ro11
               PF8=Forward      PF9=Refresh      PF12=Retrieve
```

Figure 102. INGVOTE Command Dialog Panel

- The CMD field allows you to specify command codes. To use one of the command codes shown, type the appropriate letter next to the resource name and press Enter. The following command codes are available:
  - C** Cancels the request
  - K** Cancels the request without showing the verification panel
  - S** Shows details about the request
  - V** Shows all the votes or requests that have been entered for that resource
- The Type field shows the type of the resource.
- The Name field shows the name of the resource that the request was made against.

- The Request Data field shows details about the request. Refer to the online help for further information.

The subcommands FIND/RFIND are supported. Refer to “Deciding the Format of the Command Output (Full-Screen only)” on page 13 for information.

## INGVTAM

### Purpose

The INGVAM command lets you:

- Register an application with VTAM application node recovery.
- Issue recovery commands for all applications registered with VTAM application node recovery when VTAM has restarted.
- List applications that are registered for application node recovery.
- List major nodes that are in use by applications.

### Syntax

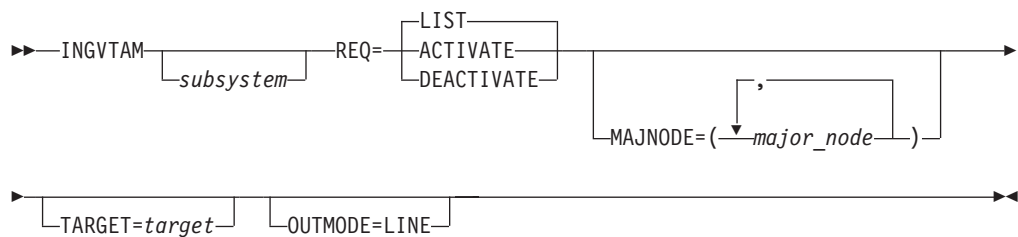

### Parameters

#### *subsystem*

The subsystem parameter specifies the name of the subsystem that is registering with SA OS/390 VTAM application recovery. This parameter is required with REQ=ACTIVATE to register a subsystem. If it is omitted with REQ=ACTIVATE, all subsystems currently registered will have the VTAMUP message command policy driven to allow them to take actions when VTAM is restored to active service. This parameter is required with REQ=DEACTIVATE.

#### REQ

Specifies the request. It can be one of the following:

**LIST** If no subsystem is specified, lists all subsystems registered for VTAM application node recovery. If a subsystem is specified, lists all the major nodes registered for that subsystem.

#### ACTIVATE

If the subsystem parameter is specified, registers the list of major nodes as specified in the MAJNODE= parameter and issues VTAM ACTIVATE commands for them. If the subsystem parameter is not specified, REQ=ACTIVATE issues the commands in the messages policy VTAMUP for every subsystem that is registered for application node recovery.

#### DEACTIVATE

A subsystem must be specified for this request. This request issues VTAM INACT commands for the major nodes that were registered

## INGVTAM

previously. INACT commands are not issued for any major node that contains model resources or is in use by another registered application.

### TARGET

For information on the TARGET parameter, refer to “Additional Parameters for System Operations Commands” on page 10.

### OUTMODE

For information on the OUTMODE parameter, refer to “Additional Parameters for System Operations Commands” on page 10.

### Restrictions and Limitations

To use the INGV TAM command system operations must be initialized.

**Note:** If the SA OS/390 NetView is not the networking NetView, the INGV TAM command and application node recovery only work partially. INGV TAM cannot issue NODEUP message policy commands when a registered major node or minor node is reactivated and VTAM issues the IST093I message. All other functions of the INGV TAM command and application node recovery work with separate SA OS/390 and networking NetViews.

### Usage

The INGV TAM command operates sysplex-wide. For an overview refer to “Overview of Commands that Operate Sysplex-Wide” on page 9. It is recommended to issue the REQ=ACTIVATE and REQ=DEACTIVATE commands on the same system as the subsystems concerned. It is recommended to place REQ=ACTIVATE in the applications PRE-START and ACORESTART policies. However, REQ=DEACTIVATE should be placed in the applications SHUTFINAL policy. For the VTAM subsystem, the INGV TAM REQ=ACTIVATE command should be defined to the UP message policy as a command.

### Examples

If you type INGV TAM subsystem REQ=LIST the output looks similar to the following:

*Figure 103. INGV TAM REQ=LIST output*

```
List of subsystems registered with VTAM
Subsystem          Subsystem          Subsystem
EYUCMS1A
*** End of Display ***
```

To register a subsystem for application node recovery, specify, for example:  
INGVTAM &SUBSAPPL REQ=ACTIVATE MAJNODE=(IPSMBC)

To deregister a subsystem for application node recovery, specify, for example:  
INGVTAM &SUBSAPPL REQ=DEACTIVATE

## JES2

### Purpose

The JES2 command issues JES2 subsystem commands so that you get a full-screen response you can page through. This is in contrast to issuing JES2 commands on the SA OS/390 command line and watching the response roll off the screen.

## Syntax

▶▶ JES2—*jes2\_command*◀◀

## Parameters

*jes2-command*

Specifies any valid JES2 command name, including parameters.

## Restrictions and Limitations

None.

## Usage

Specify the operands using any valid JES2 command syntax.

See *JES2 Commands* for command and syntax definitions.

## Examples

The DU command is used to display the status of all or specified local JES2 controlled non-direct access devices. If you type `jes2 du,all` you see a full-screen display similar to the following:

```

AOFK3GEN          SA OS/390 - Command Response Display   Page 1   of 1
Command: MVS $ DU,ALL,L=Z
                               MVS $ DU,ALL,L=Z
$HASP636 17.24.23 $DU,ALL
OFFLOAD1  DSN=SYS4.JES2.OFFLOAD1,STATUS=DRAINED,
           ARCHIVE=ONE
OFFLOAD2  DSN=SYS4.JES2.OFFLOAD2,STATUS=DRAINED,
           ARCHIVE=ONE

Action ==>

```

Figure 104. JES2 DU,ALL Display

In this example, the ALL operand displays detailed information about all local JES2 controlled devices, active remote devices, and internal readers. Note that the command line shows the actual JES2 command that was issued and not what you typed in.

## MONITOR

### Purpose

The MONITOR command causes the SA OS/390 monitoring routine to be run.

### Syntax

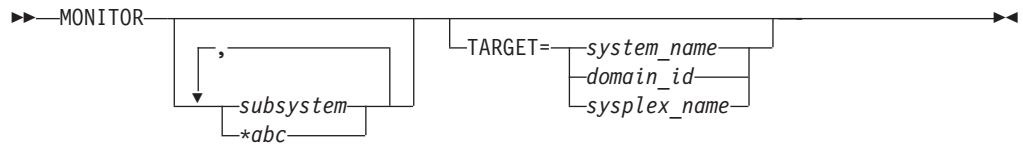

# MONITOR

## Parameters

### *subsystem*

Is the name of the subsystem you want monitored. It can be a list of subsystems. The default is that all subsystems will be monitored.

### *\*abc*

Has the effect of a filter to be applied for monitoring. Only resource names that match the filter criteria are monitored. Wildcard is supported. Valid specifications are, for example, *\*abc*, *abc\**, or *\*abc\**.

## TARGET

For information on the TARGET parameter, refer to “Additional Parameters for System Operations Commands” on page 10.

## Restrictions and Limitations

The MONITOR command can only be used when SA OS/390 is initialized.

The output of the MONITOR command is always in line mode.

## Usage

MONITOR can be used whenever you want to validate your current automation agent status information.

## Examples

To monitor TSO, VTAM and all subsystems that start with CICS®, type the following:

```
monitor TSO,VTAM,CICS*
```

# RESTART

## Purpose

The RESTART command checks a specified subsystem, or all subsystems defined to SA OS/390 on a particular system and sets the HOLD flag to No.

## Syntax

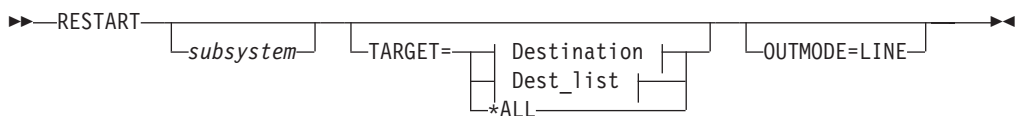

### Destination:



### Dest\_list:



**Parameters**

*subsystem*

Specifies the name of the subsystem to be allowed to start. If no subsystem name is specified, SA OS/390 attempts to restart all subsystems.

**TARGET**

For information on the TARGET parameter, refer to “Additional Parameters for System Operations Commands” on page 10.

**OUTMODE**

For information on the OUTMODE parameter, refer to “Additional Parameters for System Operations Commands” on page 10.

**Restrictions and Limitations**

The RESTART command can only be used when SA OS/390 is initialized.

**Usage**

The RESTART command can be used to enable the subsystems for start after the operator has replied NOSTART to the AOF603D reply.

**RESYNC**

**Purpose**

This command causes SA OS/390 to rerun its initial status determination routines. This will refresh the current status information for:

- Subsystems (as if at an automation control file reload)
- Outstanding replies
- SA OS/390-controlled gateway and monitor timers
- MVS console associations
- Sysplex timing
- Couple data sets
- Coupling facilities

**Syntax**

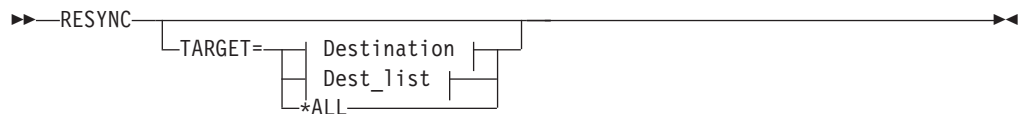

**Destination:**



**Dest\_list:**



# RESYNC

## Parameters

### TARGET

For information on the TARGET parameter, refer to “Additional Parameters for System Operations Commands” on page 10.

### Restrictions and Limitations

- The RESYNC command can only be used when SA OS/390 is initialized.
- At the end of resynchronization, subsystems in a DOWN or RESTART status may be automatically (re)started.

### Usage

This command should be used only when your statuses have gone out of synchronization with reality. Possible causes of this are SSI task failure or problems with your NetView automation table.

# SETASST

## Purpose

SETASST enables you to change a resource’s assist mode settings.

## Syntax

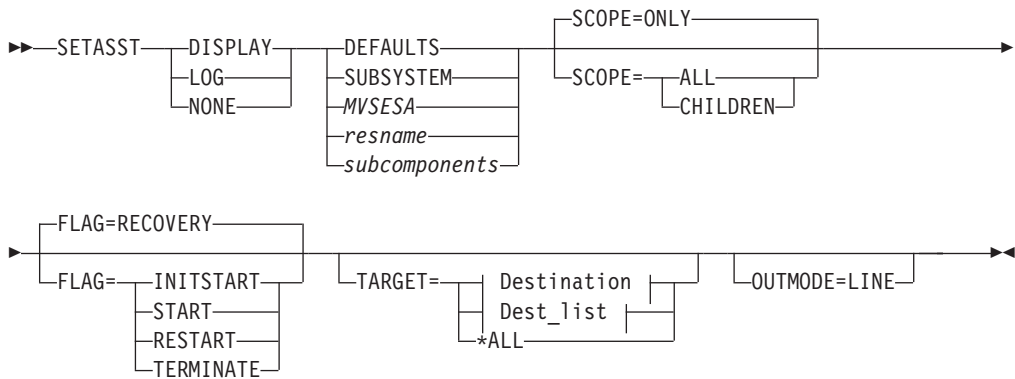

### Destination:



### Dest\_list:



## Parameters

### DISPLAY

Changes the assist mode setting for the selected automation flag to Display. This sets assist mode interactively, which means that SA OS/390 sends a

prompt to the SDF display whenever automation is triggered. This prompt tells you what the automation is intending to do, and you can decide whether or not to continue.

**LOG**

Changes the assist mode setting for the selected automation flag to log. This turns assist mode on in log mode, which means that SA OS/390 sends the assist mode prompt to the netlog. You can run the system as normal, and when an event occurs that would normally trigger automation, its details are written to the netlog.

**NONE**

Turns assist mode off for the selected automation flag.

**DEFAULTS**

Specifies the value DEFAULTS. This sets automation flags for all resources that do not have their own flags defined, or that do not belong to a group that has flags defined.

**SUBSYSTEM**

Sets defaults for all subsystems.

**MVSESA**

Sets defaults for all MVS subcomponents.

*rename*

Specifies the name of a particular resource, for example, WTOBUF. You can specify any automated resource.

*subcomponents*

Specifies any subcomponents of the resource. Enter a period (.) between each subcomponent name.

**SCOPE**

Specifies whether to change this resource and its dependent resources, dependent resources only, or this resource alone.

**ONLY**

Specifies this resource alone. This is the default.

**ALL**

Specifies this resource and its dependent resources.

**CHILDREN**

Specifies dependent resources only.

**FLAG**

Specifies the automation flags to change the assist mode settings for, (depending on whether you specified Display, Log, or None). Refer to *System Automation for OS/390 Customizing and Programming* for further information on automation flags.

**INITSTART**

Changes the assist mode setting for the Initstart flag.

**START**

Changes the assist mode setting for the Start flag.

**RECOVERY**

Changes the assist mode setting for the Recovery flag.

**TERMINATE**

Changes the assist mode setting for the Shutdown flag.

## SETASST

### RESTART

Changes the assist mode setting for the Restart flag.

### TARGET

For information on the TARGET parameter, refer to “Additional Parameters for System Operations Commands” on page 10.

### OUTMODE

For information on the OUTMODE parameter, refer to “Additional Parameters for System Operations Commands” on page 10.

### Restrictions and Limitations

Do not activate SETASST DISPLAY mode for any resources until VTAM is active and you are able to log on to NetView. Doing so can result in situations where automation is unable to continue as you are unable to access SDF to respond to the ASSIST DISPLAY dialog.

The SETASST command can only be used when SA OS/390 is initialized.

### Usage

SETASST is used as an alternative to updating and reloading the automation control file. SCOPE=ONLY is the only valid scope for DEFAULTS, resource type, and subcomponents. ALL and CHILDREN are not valid.

### Examples

To turn the assist mode on in LOG mode for the TSO restart flag, type the following:

```
setasst log,tso,flag=restart
```

## SETHOLD

### Purpose

SETHOLD lets you select which AOF messages are held on your operator ID. This command is used by the INGNTFY command but can be invoked separately.

### Syntax

```
▶▶ SETHOLD |-----▶▶
```

### SETHOLD

```
|SETHOLD | Parameters |-----|
```

### Parameters

```
|-----|
| CONFIG |
| AUTO   |
| i a e d w |
```

### Parameters

#### CONFIG

Specifying this option changes your hold settings to match the settings specified for your operator ID in the automation control file. If your operator ID is not defined as a notification operator, no messages will be held.

#### AUTO

Specifying this option changes your hold settings to match the settings INGNTFY has defined currently for your operator ID. If your operator ID is not a notification operator or if its definition as a notification operator has been deleted, no messages will be held.

#### i a e d w

Each character specifies the hold setting for the corresponding type of message. If a Y is specified, messages of that type will be held, if any other character is specified, messages of that type will not be held. A character must be specified for each type.

### Restrictions and Limitations

- The SETHOLD command is only useful on an OST task. If issued on an NNT or RMT task, the message holding flags in the remote domain will be ignored, as the automation table on the OST task will override whatever message attributes may have been specified in the remote domain.
- SETHOLD does not update the INGNTFY globals, so if you use it with anything other than the AUTO parameter, the hold settings shown by INGNTFY QUERY may not reflect reality.

### Usage

SA OS/390 issues SETHOLD at SA OS/390 initialization, when you log on to NetView interface, and when INGNTFY is used.

When you log on, an entry in the sample automation table (in member AOFMSGMS) will invoke SETHOLD AUTO for your operator ID. When INGNTFY

## SETHOLD

is used to change an operator' HOLD settings, SETHOLD AUTO will be issued on the appropriate OST task after the global information has been updated.

A more efficient usage would be to modify your initial CLISTs to issue SETHOLD with specific settings and to not have any hold settings specified in the automation control file or through INGNTFY. If you choose to do this, you will need to remove the automation table entry for the OST (in member AOFMSGMS) and set the AOFLOCALHOLD advanced automation option to 1. Doing this will stop INGNTFY from using EXCMD to issue SETHOLD AUTO, which can disrupt the hold settings specified from your profiles.

Note that the attributes for held messages are defined as automation table synonyms in the AOFMSGSY member.

It is recommended that you do not hold information messages as SA OS/390 can generate quite a few of them. If you do hold them, use the CLRHELD command to remove them. You may wish to modify the attributes for held information messages (held in the AOFMSGSY ACF member) so that held information messages will not actually be held.

### Examples

To hold the messages that INGNTFY says you should have held, type SETHOLD AUTO. Messages will be held according to the task INGNTFY setting.

To hold all but information message, type SETHOLD N Y Y Y Y. All AOF messages, except informational ones, will be held.

## SETSTATE

### Purpose

SETSTATE changes the agent automation status of a given subsystem.

### Syntax

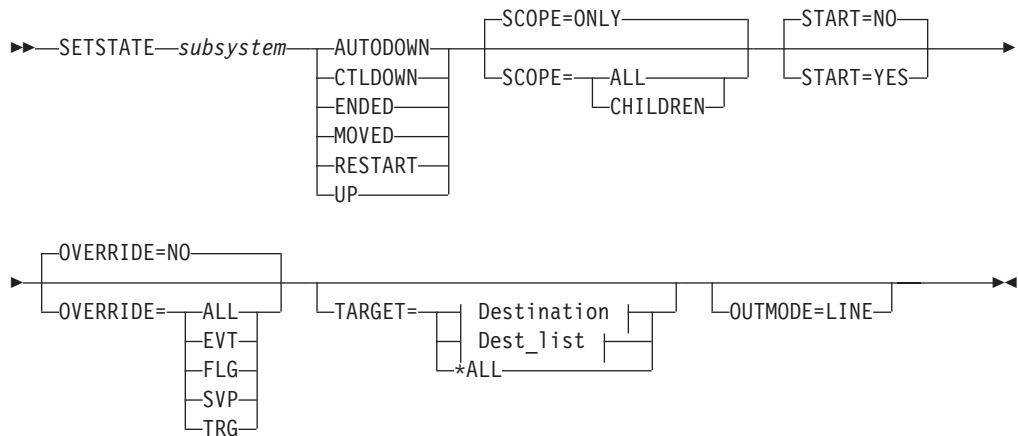

### Destination:



**Dest\_list:****Parameters***subsystem*

Specifies the subsystem whose status (or whose dependent resource's status) you want to change. You can also specify the subsystem's job name.

**AUTODOWN**

Changes the status from CTLDOWN, STOPPED, BROKEN, MOVED or FALLBACK to AUTODOWN. It is primarily used to return the resource to automation control after the operator has fixed the problem.

**CTLDOWN**

Changes the status to CTLDOWN so that the subsystem cannot be started by automation.

**ENDED**

Changes the status to ENDED

**MOVED**

The effect of this parameter depends on how the subsystem is defined.

- If the subsystem does not have any secondary system associations, the effect of the MOVED operand is the same as the effect of the CTLDOWN operand: the status of the subsystem is changed to CTLDOWN.
- If the subsystem does have secondary system associations:
  - If the command is issued on one of the subsystem's primary systems, the subsystem's status is changed to MOVED
  - If the command is issued on one of the subsystem's secondary systems, the subsystem's status is changed to FALLBACK.

**RESTART**

Changes the status to RESTART so that the subsystem can be restarted. Specify this if your Initstart flag is set to No.

**UP**

Changes the status to UP/RUNNING if the subsystem's UPMSG has been missed. This can only be used when:

- SCOPE=ONLY
- The application monitor status of the subsystem is ACTIVE
- If the subsystem is enabled for automatic restart management, its automatic restart management status must be AVAILABLE or AVAILABLE-TO

**Note:** For transient subsystems, UP becomes RUNNING.

**SCOPE**

Specifies what is affected by this command:

**ONLY** Changes the status of this resource only. This is the default.

**ALL** Changes the status of this resource and its dependent resources.

**CHILDREN**

Changes the status of the dependent resources only.

## SETSTATE

### OVERRIDE

Specifies the overrides to be considered for the request. It can be one of the following:

- NO** Specifies that no override will be done. This is the default.
- ALL** Sets the FLG, TRG, SVP, and EVT overrides on.
- EVT** The startup/shutdown conditions will be ignored.
- FLG** The appropriate automation flags will be ignored for the resource.
- SVP** The service period will be ignored.
- TRG** The current trigger settings will be ignored.

### START

Specifies whether the resource is started after the status has been updated.

#### NO

No request is sent to the automation manager. The automation agent status is updated. This is the default.

#### YES

A default start request is sent to the automation manager.

### TARGET

For information on the TARGET parameter, refer to “Additional Parameters for System Operations Commands” on page 10.

### OUTMODE

For information on the OUTMODE parameter, refer to “Additional Parameters for System Operations Commands” on page 10.

## Restrictions and Limitations

The SETSTATE command will not execute under the primary POI task (PPT).

The SETSTATE command can only be used when SA OS/390 is initialized.

## Usage

Use SETSTATE to:

- Resume handling an application after a manual operator shutdown or after any other event that causes an application to get into a non-automatable status (for example STOPPED, CTLDOWN, BROKEN, ACTIVE)
- Prevent automation from restarting an application if you specify CTLDOWN
- Alert the automation that an application that was shut down will be moved to another system.
- The SETSTATE command issues an automation manager request with a priority of HIGH (unless overridden by the advanced automation global INGREQ\_PRI). Because requests entered by the operator are persistent, it may be necessary to manually remove the associated vote before subsequent requests are activated.

## Examples

If you type setstate TS0 a panel similar to the following is displayed:

```

AOFKSAST          SA OS/390 - Command Dialogs
Domain ID = IPSNO  ----- SETSTATE -----   Date = 07/19/00
Operator ID = NETOP1                               Time = 18:53:29

Specify subsystem and new state:

Subsystem => TSO          Subsystem to be processed
System   =>              System name, domain ID, sysplex name or *ALL
State    => autodown     Put subsystem in the following state:
                        (RESTART / AUTODOWN / CTLDOWN / UP / ENDED /
                        MOVED)

Scope    => ONLY        Change state for:
                        ONLY   - only this subsystem
                        CHILDREN - only dependant subsystems
                        ALL    - resource and dependants

Start    => NO          Start or restart subsystem now (YES/NO)
Override => NO          Override(Start=YES) (NO/FLG/TRG/SVP/EVT/ALL)

Command ==>
PF1=Help   PF2=End   PF3=Return   PF6=Ro11

```

Figure 105. SETSTATE Command Dialog Panel

## SETTIMER

### Purpose

SETTIMER displays all scheduled timers. You can also add, change, or delete timers.

### Syntax

```

▶▶ SETTIMER [TARGET=system_name [OUTMODE=LINE]
             [domain_ID]
             [sysplex_name]]
◀◀

```

### Parameters

#### TARGET

For information on the TARGET parameter, refer to “Additional Parameters for System Operations Commands” on page 10.

#### OUTMODE

For information on the OUTMODE parameter, refer to “Additional Parameters for System Operations Commands” on page 10.

### Restrictions and Limitations

The SETTIMER command can only be used when SA OS/390 is initialized.

If you want to use the SETTIMER command instead of the NetView SDETTIMER command, you must change the command synonyms. For further information refer to *System Automation for OS/390 Planning and Installation*.

### Usage

For instructions on how to add, change, or delete timers, refer to *System Automation for OS/390 User's Guide*.

**Examples**

When you type settimer a panel similar to the following is displayed:

```

AOFKATI          SA OS/390 - Command Dialogs   Line 1   of 16
Domain ID = IPSFP ----- SETTIMER -----   Date = 06/28/02
Operator ID = NETOP1      System = KEY4        Time = 15:54:50
Enter ADD on the COMMAND line to create a new timer entry
or use CMD selections A add, C change, or D delete to modify existing timers.
CMD TIMER-ID SCHEDULED TIME   TYPE TASK   INTERVAL   CLOCK SAVE CTUP
-----
MEMSTORE 06/28/02 15:56:03 EVERY AUTO2   000 00:02:00 GMT NO
  Cmd: MEMSTORE 5% 5
IDLEOFF  06/28/02 16:00:13 EVERY AUTO1   000 00:10:00 GMT NO
  Cmd: IDLEOFF 60
AOFGATE  06/28/02 16:01:55 EVERY PPT      000 00:15:00 GMT NO
  Cmd: AOFRASCD GATOPER AOFRI1GT
AOFCCON  06/28/02 16:13:55 EVERY PPT      000 00:59:00 GMT NO
  Cmd: AOFRASCD SYSOPER MVS D C
AOFMON   06/28/02 16:13:55 EVERY PPT      000 00:59:00 GMT NO
  Cmd: AOFRASCD MONOPER MONITOR $SYSTEM
AOFI0001 06/28/02 18:00:00 AT      PPT                LOCAL NO
  Cmd: AOFRASCD MONOPER AOFRASAF AUTOMATION MVSESA,OPTION=RESET

Command ==>>
PF1=Help      PF2=End      PF3=Return    PF6=Ro11
PF8=Forward   PF9=Refresh  PF12=Retrieve
    
```

Figure 106. Display of Scheduled Timers (SETTIMER)

- The CMD field allows you to specify whether you want to add, change, or delete a timer. Valid values are:
  - A** Add a new timer with the same values as the one selected
  - C** Change an existing timer
  - D** Delete a timer
- The TIMER-ID field shows the name assigned to the timer.
- The SCHEDULED TIME field shows the next scheduled day and time that this timer is set to expire.
- The TYPE field shows the type of timer. There are three types:
  - At** Set to occur at the specified date and time. Occurs only once.
  - Every** Set to occur at the time intervals indicated in the Interval field, or at a specific time each day or week.
  - After** Set to occur only after the elapsed time that was specified when the timer was scheduled. For example, if at 12:00 am, you specify 2 hours, the timer will expire at 02:00 pm.
- The TASK field shows the operator where the timer runs. This could be a primary programmed operator interface task (PPT), an automation operator, or a human operator.
- The CLOCK field specifies the time format. It can be GMT or LOCAL.
- The SAVE field specifies whether or not the timer is to be saved to an external file. This allows the timer to be restored after a NetView outage. This applies to timers created using either the customization dialog or the operator interface. Valid values are YES or NO. The default is YES.
- The CTUP field specifies whether or not to activate the timer if it occurs at a time when NetView is down. Valid values are Yes or No. If CTUP is set to YES, the command specified in the timer definition is issued when NetView is restarted, if the timer expired while NetView was down.

The field can only be set to YES if:

- This is an At type timer (it occurs once at a specific time and date).
- The timer was created using the customization dialog.
- The Save field is set to YES
- The Interval field is only valid for Every type timers. It indicates the time intervals at which the timer is set to occur. For example, a value of 00:30:00 means that the timer will issue the command specified every 30 minutes.
- The Command field specifies the command to be issued when this timer expires.

## SETTIMER

---

## Part 3. SA OS/390 I/O Operations Commands

<b>I/O Operations Commands</b> . . . . .	211	DISPLAY VARY . . . . .	236
Using I/O Operations Commands . . . . .	211	GETLOCK . . . . .	238
FICON Switches . . . . .	211	LOGREC . . . . .	238
FICON Cascaded Switches . . . . .	211	PROHIBIT . . . . .	239
ALLOW . . . . .	212	REMOVE CHP . . . . .	241
BLOCK . . . . .	214	REMOVE SWITCH . . . . .	243
CHAIN . . . . .	216	RESET HOST . . . . .	245
CONNECT . . . . .	219	RESET SWITCH . . . . .	248
DISCONNECT . . . . .	220	RESET TIMEOUT . . . . .	248
DISPLAY CHP . . . . .	221	RESTORE CHP . . . . .	249
DISPLAY DEVICE . . . . .	223	RESTORE SWITCH . . . . .	251
DISPLAY HOST . . . . .	225	SYNC SWITCH. . . . .	252
DISPLAY NAME . . . . .	227	UNBLOCK . . . . .	253
DISPLAY PORT . . . . .	229	UNCHAIN . . . . .	254
DISPLAY RESULTS . . . . .	231	UNLOCK . . . . .	256
DISPLAY SWITCH . . . . .	234	WRITE . . . . .	257
DISPLAY TIMEOUT . . . . .	236		

This part describes SA OS/390 I/O operations commands in detail—their purpose, format, and specifics of how to use them.

For general information about SA OS/390 commands, refer to *System Automation for OS/390 User's Guide*.



---

## I/O Operations Commands

---

### Using I/O Operations Commands

You can issue I/O operations commands by entering the command through:

- ISPF dialogs
- The operator console

Not all commands can be issued in both ways. For detailed information about where the commands can be used and about the authorization levels they require, refer to Appendix B, “General Considerations for I/O Operations Commands”, on page 351.

---

### FICON Switches

FICON switches allow imbedded space characters on port names. Consequently, I/O operations will no longer issue message IHVD106I when detecting imbedded blanks in port names of FICON switches.

However, I/O operations does not support imbedded blanks on port names, either in the ISPF dialogs or in the console command interface. The reason is that generic names and port names must not contain imbedded blanks when used in I/O operations console commands.

---

### FICON Cascaded Switches

I/O operations supports cascaded switches with some restrictions:

1. All switches must be channel attached to the same channel subsystem that I/O operations is running on. A FICON cascaded switch that has not been channel attached is not visible to I/O operations and can cause unexpected results.
2. For CTC connections on cascaded switches, I/O operations can neither display CTC control unit data nor manage CTC devices. The reason for this is that when I/O operations attempts to determine the attached NDs of such a device, it can get stuck behind a never-ending channel program on the device.
3. The Block command is not supported on Inter-Switch-Link ports (E\_Ports). When an E\_Port is affected by the command, it is rejected with return code 8 and reason code X'49'. In addition, the message IHVC913I is issued, showing the first or only port that is affected by the command.
4. All other I/O operations commands affecting E\_Ports (Allow, Prohibit, Unblock, WRITEPORT and WRITESWCH) must specify the command option IGNore when an E\_Port is involved. Otherwise the command is rejected with return code 8 and reason code X'49'. In addition, the message IHVC913I is issued, showing the first or only port that is affected by the command.

The IGNore option makes the issuer of the command aware that *safe-switching* can no longer be guaranteed. Safe-switching sets the paths and devices online or offline when the path from a chpid to a device becomes valid, or is no longer valid because of port manipulation.

5. If an attached Node Descriptor of a device cannot be determined because the path or channel is offline, the Display Device command does not show any control unit data for the particular channel path id.

# ALLOW

## Purpose

Use the *ALLOW* command to define a dynamic connection between ports on one switch or on all the switches allocated to the issuing I/O operations.

You can allow the dynamic connections that are shown in the following syntax diagram. With the *ALLOW* command, you can, for example, define partitions within a system to facilitate maintenance. For information on the reciprocal command, refer to “PROHIBIT” on page 239.

## Syntax

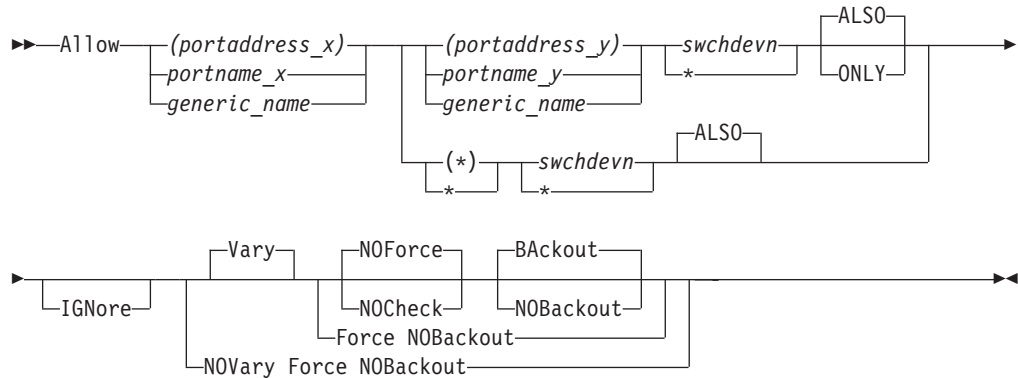

## Parameters

### (portaddress\_x) | portname\_x | generic\_name

Specifies the target port by its port address (enclosed in parentheses), by its individual port name, or by a generic port name. For a discussion, see “Port Switching Commands” on page 345.

### (portaddress\_y) | portname\_y | generic\_name | (\*) | \*

Specifies one of the following: the port address of a second port (enclosed in parentheses), the port name of a second port, a generic port name, all other port addresses (\* enclosed in parentheses), or all other port names (\* not enclosed in parentheses). For a discussion, see “Port Switching Commands” on page 345.

### swchdevn | \*

Specifies one switch or all switches (\* not enclosed in parentheses) that are allocated to the issuing I/O operations. For a discussion, see “Switch Identifiers” on page 333.

## Options

### ALSO | ONLY

**ALSO** (default) specifies that the ports affected by the command will connect dynamically to each other, regardless of whether they connect dynamically to other ports on the same switch.

**ONLY** specifies that the ports affected by the command will connect dynamically to each other, but each port is disallowed a dynamic connection to any other port on the switch.

**IGNore**

You must specify this option when an Inter-Switch-Link port (E\_Port) is involved. Otherwise the command is rejected with return code 8 and reason code X'49'. The reason is I/O operations can no longer guarantee "safe-switching" when an E\_Port is involved.

"Safe-switching" sets the paths and devices online or offline when the path from a chpid to a device either becomes valid or is no longer valid because of a port manipulation.

**Connectivity options**

For a discussion on Vary | NOVary, NOForce | NOCheck | Force, and BAckout | NOBAckout see "Making Connectivity Changes" on page 340.

**Usage**

- If you specify an individual or generic port name, all the switches involved must have at least 1 port implemented with an applicable port name.
- If you specify the same port in both operands and do not specify a generic name, the command will fail because I/O operations will not allow that port to have a dynamic connection with itself.
- If you specify 1 or 2 generic names and at least 1 port in each operand is unique and valid, the command will succeed. I/O operations will allow the valid dynamic connections and disallow a port to connect to itself.
- Although you cannot use the ONLY option and specify either all port addresses (\*) or all port names \*, you can specify a generic port name. Assume, for example, that all the ports on switch 100 are named and the names start with F: FC1, FC2, FC3, and so on. Although you cannot specify A \* \* 100, you can specify A F\* F\* 100.
- When you specify the ONLY option, all paths to the specified ports are varied offline. The dynamic path between the two ports is varied online.
- If a parallel channel and CV converter are involved, you should consider the information provided in "A Parallel Channel in Block (BL) Mode" on page 347.

**Examples**

In the following example, port *FB* is allowed to have a dynamic connection only with port *D6* on switch 100. The dynamic connections that port *FB* had with other ports are now prohibited.

```
A (FB) (D6) 100 ONLY
IHVCO00I ALLOW      command successful
```

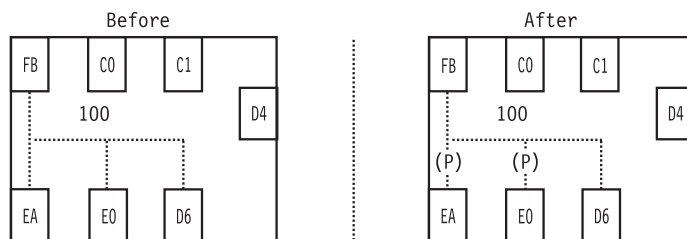

Figure 107. ALLOW Command - Sample 1

## ALLOW

In the following example of using a generic port name, all the ports whose port names start with the characters *HB.CHP\_39* are allowed to have dynamic connections with ports that begin with *CU.* on switch 200.

```
ALLOW HB.CHP_39 CU.* 200
IHVC000I ALLOW      command successful
```

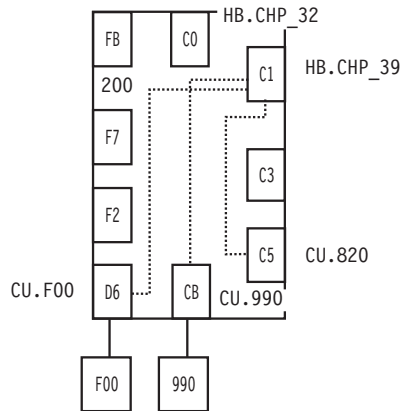

Figure 108. ALLOW Command - Sample 2

## BLOCK

### Purpose

Use the BLOCK command to prevent data transfer through the specified port on one or on all the switches allocated to the issuing I/O operations.

See "UNBLOCK" on page 253 for information on the reciprocal command.

### Syntax

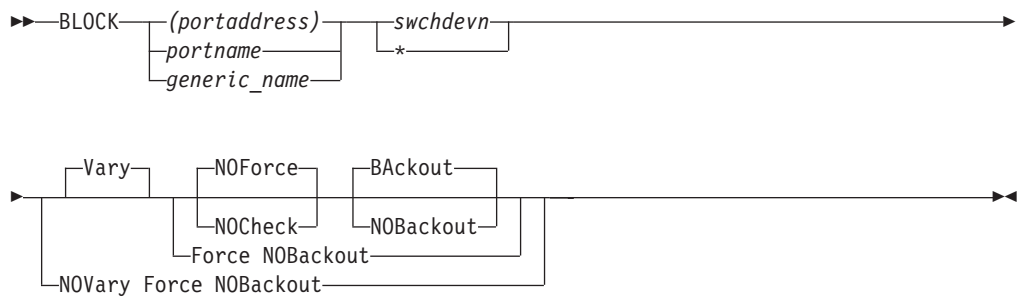

### Parameters

**(portaddress) | portname | generic\_name**

Specifies the ports to be blocked by an individual port address, by an individual port name, or by a generic port name. For a discussion, see "Port Switching Commands" on page 345.

`swchdevn | *`

Specifies one switch or all switches (\* not enclosed in parentheses) allocated to the issuing I/O operations. For a discussion, see “Switch Identifiers” on page 333.

## Options

### Connectivity options

For a discussion on `Vary | NOVary`, `NOForce | NOCheck | Force`, and `BAckout | NOBAckout` see “Making Connectivity Changes” on page 340.

## Restrictions and Limitations

The command is rejected with return code 8 and reason code X'49' when an Inter-Switch-Link port (E\_Port) is affected. The reason is that I/O operations does not know the paths and devices to be varied offline.

## Usage

- If a CVC CHPID is involved, “An ESCON-in-Converted-Mode (CVC) Path” on page 343 provides more information.
- If a parallel CHPID is involved, “A Parallel Channel in Block (BL) Mode” on page 347 provides more information.

## Examples

```
B (D6) 100
IHVC000I BLOCK      command successful
```

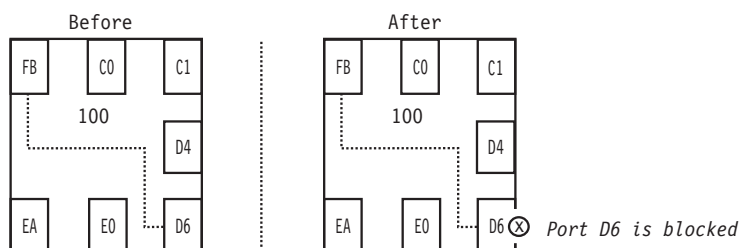

Figure 109. BLOCK Command - Sample 1

In the following example of using a generic port name, all ports whose port names start with the characters `CU.F` are blocked on all the switches allocated to the issuing I/O operations.

```
B CU.F* *
IHVC000I BLOCK      command successful
```

## CHAIN

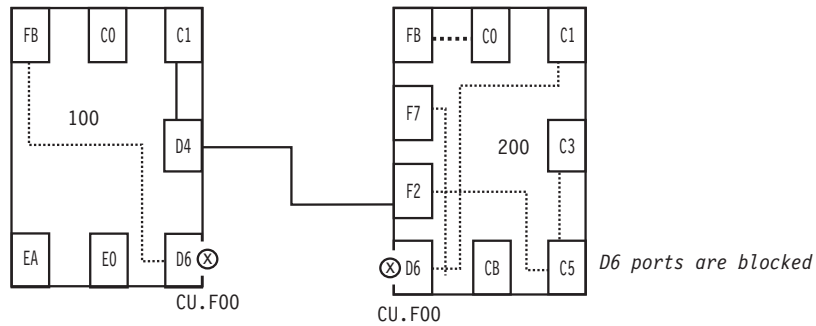

Figure 110. BLOCK Command - Sample 2

## CHAIN

### Purpose

Use the CHAIN command to define a chain in a chained path that traverses two switches that are physically linked to each other.

One switch acts as a fiber repeater and is called the passthru switch. Two ports in the chain are statically connected to each other in the passthru switch. The other switch is called the destination switch because the chain “ends” in that switch.

For more information, see “Chain and Unchain a Switchable Path” on page 334. See “UNCHAIN” on page 254 for the reciprocal command.

**Note:** The CHAIN command is not applicable to FICON switches.

### Syntax

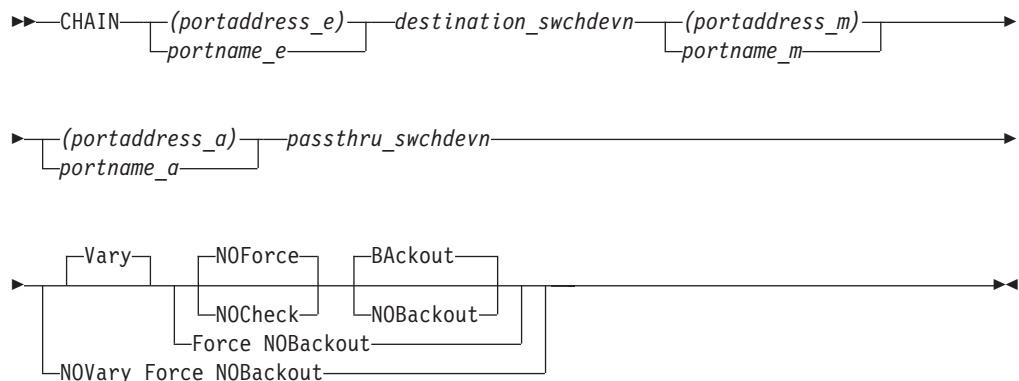

### Parameters

#### (portaddress\_e) | portname\_e

Specifies the port ending the chain on the destination switch by its port address (enclosed in parentheses) or by its port name. For a discussion, see “Port Switching Commands” on page 345.

#### destination\_swchdevn

Specifies the device number of the destination switch, which is the switch that ends the chain. For a discussion, see “Switch Identifiers” on page 333.

**(portaddress\_m) | portname\_m**

Specifies middle port by its port address (enclosed in parentheses) or by its port name. For a discussion, see “Port Switching Commands” on page 345.

**(portaddress\_a) | portname\_a**

Specifies the port to which the CHPID or control unit is physically attached to the beginning of the chained path by its port address (enclosed in parentheses) or by its port name. For a discussion, see “Port Switching Commands” on page 345.

**passthru\_swchdevn**

Specifies the device number of the passthru switch, which is the switch that has the static connection between ports *a* and *m*. For a discussion, see “Switch Identifiers” on page 333.

## Options

### Connectivity options

For a discussion on Vary | NOVary, NOForce | NOCheck | Force, and BAckout | NOBAckout see “Making Connectivity Changes” on page 340.

## Usage

- Additional steps may be required. See “Chain and Unchain a Switchable Path” on page 334.
- If you need to define a chain, consider entering the Chain command when I/O operations is started so that the program can take the definition into account for all vary path processing.
- Chaining can add complexity to I/O operations’ vary path processing. See “Chain and Unchain a Switchable Path” on page 334 for more information.

## Examples

```
CHAIN (F2) 200 (D4) (C1) 100
IHVC000I CHAIN          command successful
```

# CHAIN

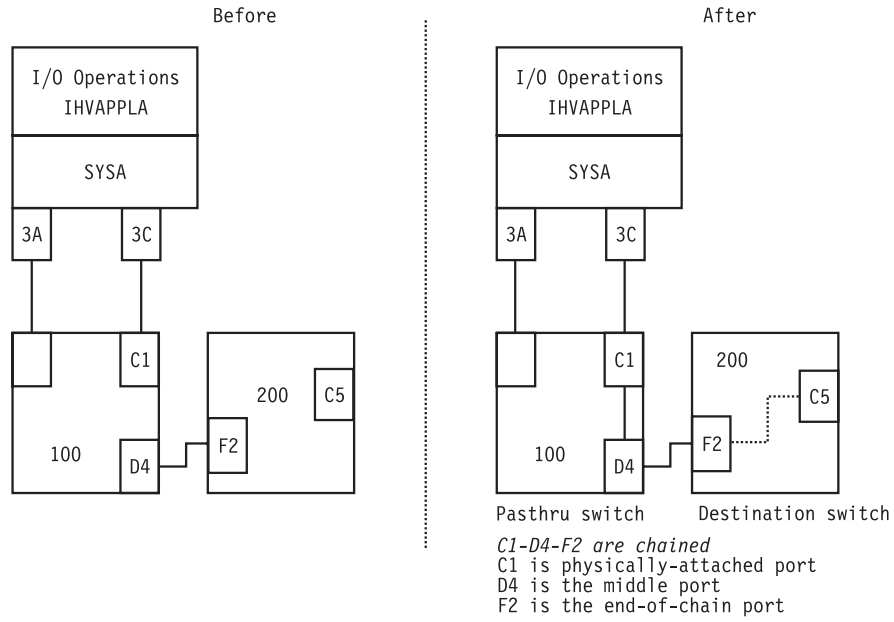

Figure 111. CHAIN Command - Sample 1

```
CHAIN (E0) 100 (D6) (CB) 200
IHVC000I CHAIN            command successful
```

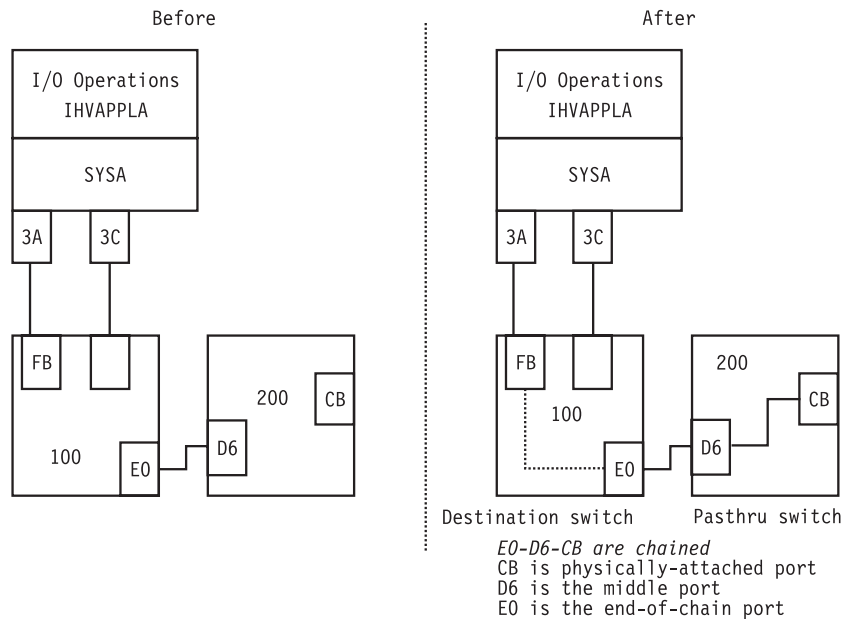

Figure 112. CHAIN Command - Sample 2

## CONNECT

### Purpose

Use the CONNECT command to establish a static, or dedicated, connection between two ports on the same switch or those same two ports on all switches allocated to the issuing I/O operations.

See “DISCONNECT” on page 220 for the reciprocal command.

**Note:** The CONNECT command is not applicable to FICON switches.

### Syntax

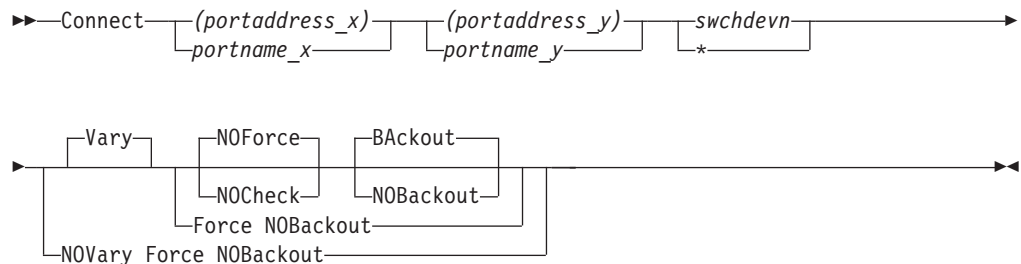

### Parameters

#### (portaddress\_x) | portname\_x

Specifies one target port on the switch by its port address (enclosed in parentheses) or by its port name. For a discussion, see “Port Switching Commands” on page 345.

#### (portaddress\_y) | portname\_y

Specifies the other target port by its port address or by its port name. For a discussion, see “Port Switching Commands” on page 345.

#### swchdevn | \*

Specifies one switch or all switches (\* not enclosed in parentheses) allocated to the issuing I/O operations. For a discussion, see “Switch Identifiers” on page 333.

### Options

#### Connectivity options

For a discussion on Vary | NOVary, NOForce | NOCheck | Force, and BAckout | NOBAckout see “Making Connectivity Changes” on page 340.

### Usage

The two ports on the passthru switch of a chain are implicitly connected by the Chain command. Under some circumstances, however, you will need to enter the Connect command in addition to the Chain command. See “Chain and Unchain a Switchable Path” on page 334 for more information.

## CONNECT

### Examples

In the following example, ports *C0* and *D6* become statically connected. In the hierarchy of port attributes, a static connection overrides a dynamic connection. Therefore, port *EA* cannot communicate with port *C0* as long as the latter remains statically connected.

See “Port Switching Commands” on page 345 for more information.

```
C (FB) (D6) 100
IHVC000I CONNECT    command successful
```

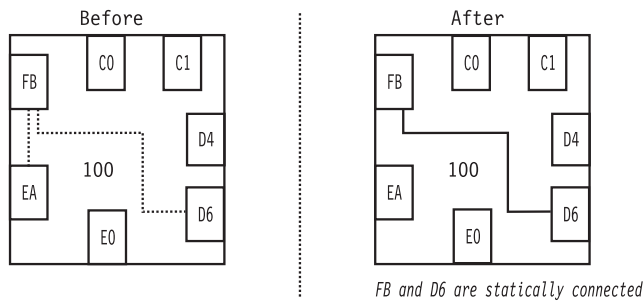

Figure 113. CONNECT Command - Sample

## DISCONNECT

### Purpose

Use the DISCONNECT command to cancel the definition of a static, or dedicated, connection between two ports on the same switch or those same two ports on all switches allocated to the issuing I/O operations.

See “CONNECT” on page 219 for the reciprocal command.

**Note:** The DISCONNECT command is not applicable to FICON switches.

### Syntax

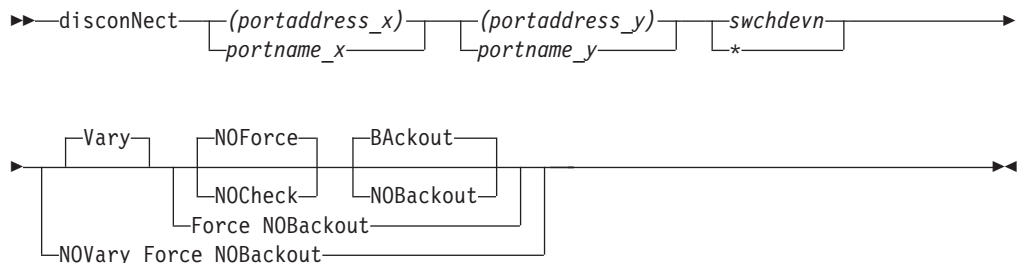

### Parameters

**(portaddress\_x) | portname\_x**

Specifies one target port on the switch by its port address (enclosed in parentheses) or by its port name. For a discussion, see “Port Switching Commands” on page 345.

**(portaddress\_y) | portname\_y**

Specifies the other target port by its port address or by its port name.

**swchdevn | \***

Specifies one switch or all switches (\* not enclosed in parentheses) allocated to the issuing I/O operations. For a discussion, see “Switch Identifiers” on page 333.

## Options

### Connectivity options

For a discussion on Vary | NOVary, NOForce | NOCheck | Force, and BAckout | NOBAckout see “Making Connectivity Changes” on page 340.

## Usage

If a CVC CHPID is involved, “An ESCON-in-Converted-Mode (CVC) Path” on page 343 provides more information.

## Examples

```
N (FB) (D6) 100
IHVC0001 DISCONNECT command successful
```

---

## DISPLAY CHP

### Purpose

Use the DISPLAY CHP command to display data about one or about all the channel path identifiers (CHPIDs) online to the operating system (host) image on which the issuing I/O operations is running.

### Syntax

```
▶▶—DISPLAY CHP—chpid————▶▶
      |
      |*
      |
```

### Parameters

**chpid**

Specifies a single channel path identifier (CHPID)

\* All CHPIDs known to the issuing I/O operations

### Usage

For more information on the data displayed, see the page references under the fields:

```
IHVC824I                                PORT
IHVC825I    CHP    SWCH                STATUS
IHVC826I    CHP TYPE  DEVN LSN PORT  H S C P PORT NAME
A         B C    D E F G         H
```

**A**  
**B**  
**C**

Message

Channel path ID (see “Channel Types” on page 338)

Channel type (see “Channel Types” on page 338)

## DISPLAY CHP

- D** Switch device number (see “Switch Identifiers” on page 333)
- E** Logical switch number (see “Logical Switch Number (LSN)” on page 334)
- F** Port address (see “Port Addresses” on page 348)
- G** Port status codes (see “Switch Port Hardware Status on a Display Command” on page 344)
- H** Port name (see “Using Port Names as a Tool in Switching Commands” on page 343)

### Examples

```

D C 3C
IHVC815I
IHVC816I      CHP      SWCH      PORT
              TYPE     DEVN LSN PORT H S C P PORT NAME
IHVC817I CHP   CNC_S   0200 02  F2  C   HA.CHP_3C
IHVC818I 3C    CNC_S   0100 01  D4  C   LINK.200
IHVC819I CHAINED TO: 0100 01  D4  C   C1   LINK.200
IHVC820I D4 CONNECTED TO:      C1  C   D4   HA.CHP_3C
    
```

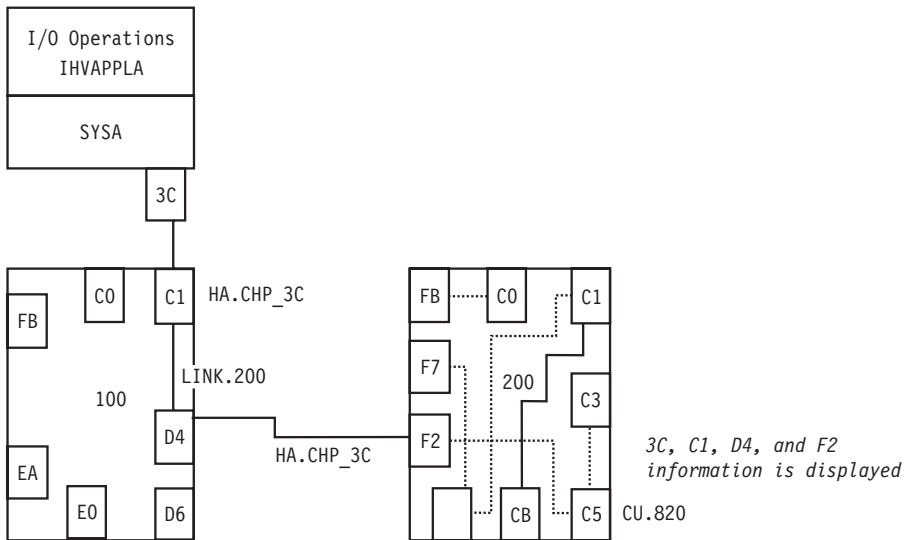

Figure 114. DISPLAY CHP Command - Sample 1

```

D C 3A
IHVC815I
IHVC816I      CHP      SWCH      PORT
              TYPE     DEVN LSN PORT H S C P PORT NAME
IHVC817I CHP   CNC_S   0100 01  FB  P   HA.CHP_3A
    
```

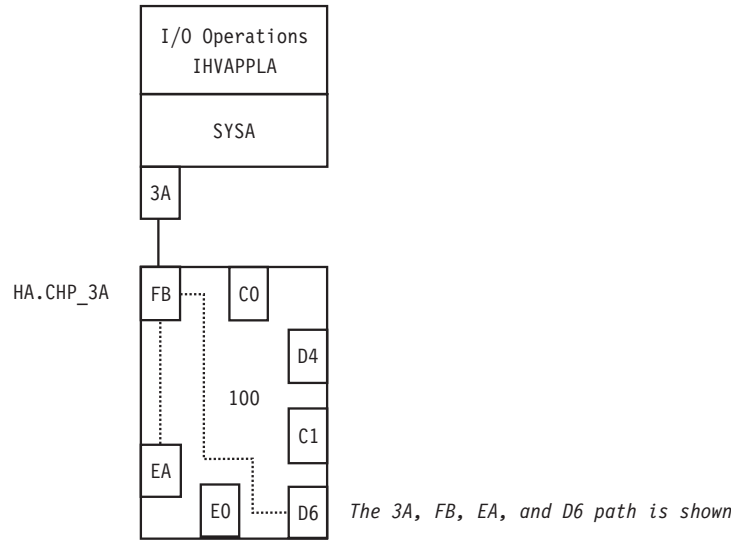

Figure 115. DISPLAY CHP Command - Sample 2

## DISPLAY DEVICE

### Purpose

Use the DISPLAY DEVICE command to display data about one, a range, or all the devices connected to one or all the switches that are allocated to the issuing I/O operations.

### Syntax

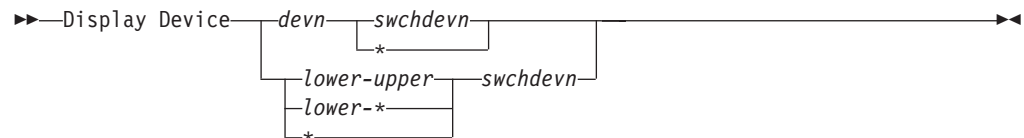

### Parameters

**devn**

A specific device number

**lower-upper**

The range of device numbers from the *lower* limit, followed by a hyphen - and the *upper* limit

**lower-\***

The range of device numbers from the *lower* limit, followed by a hyphen - and an asterisk (\* not enclosed in parentheses) to indicate the highest number.

\* All the device numbers (\* not enclosed in parentheses)

**swchdevn**

Specifies one switch allocated to the issuing I/O operations

\* All switches allocated to the issuing I/O operations. For a discussion, see "Switch Identifiers" on page 333.

## DISPLAY DEVICE

### Restrictions and Limitations

If an attached Node Descriptor (ND) of a device on a cascaded switch cannot be determined because the path or channel is offline, no control unit data is shown for the particular channel path id.

This is always true for CTC connections on cascaded switches. The reason is that I/O operations can get stuck behind a never-ending channel program on a CTC device when attempting to determine the attached NDs of the device.

### Usage

For more information on the displayed output, see the page references under the fields.

```
IHVC824I
IHVC825I          CHP  SWCH          PORT
IHVC826I  DEVN CHP TYPE  DEVN LSN PORT H S C P PORT NAME
A          B  C  D    E  F    G    H
```

- A** Message
- B** Channel path ID (see “Channel Types” on page 338)
- C** Channel type (see “Channel Types” on page 338)
- D** Switch device number (see “Switch Identifiers” on page 333)
- E** Logical switch number (see “Logical Switch Number (LSN)” on page 334)
- F** Port address (see “Port Addresses” on page 348)
- G** Port status codes (see “Switch Port Hardware Status on a Display Command” on page 344)
- H** Port name (see “Using Port Names as a Tool in Switching Commands” on page 343)

### Examples

```
D D F01 *
IHVC824I
IHVC825I          CHP  SWCH          PORT
IHVC826I  DEVN CHP TYPE  DEVN LSN PORT H S C P PORT NAME
IHVC827I 0F01 3A  CNC_S 0100 01  FB          HA.CHP_3A
IHVC82AI CNTL UNIT DATA:0100 01  D6          CU.F00
IHVC827I          3D  CNC_S 0200 02  F7          HA.CHP_3D
IHVC82AI CNTL UNIT DATA:0200 02  D6          CU.F00
```

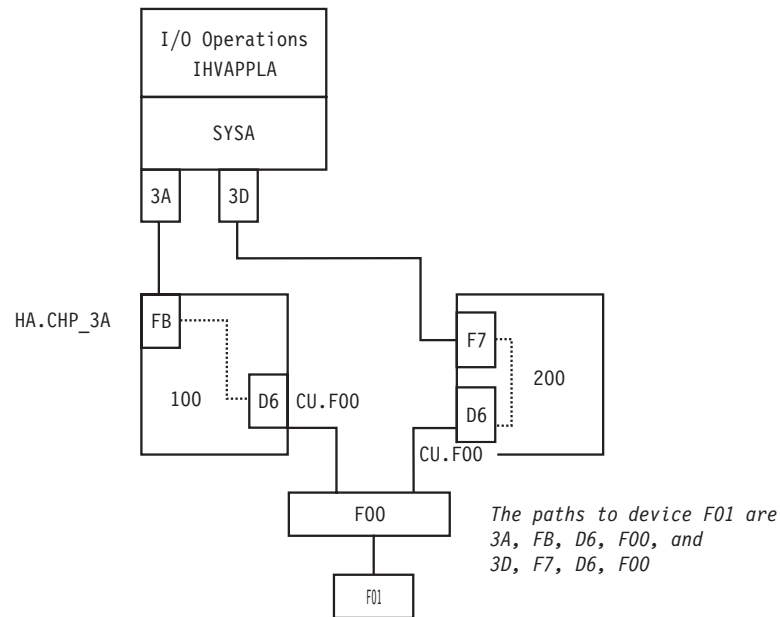

Figure 116. DISPLAY DEVICE Command - Sample

## DISPLAY HOST

### Purpose

Use the DISPLAY HOST command to display status about the specified I/O operations(host).

See “DISPLAY RESULTS” on page 231 for the related command, and “Processing a Vary Path Request” on page 349 for more information.

### Syntax

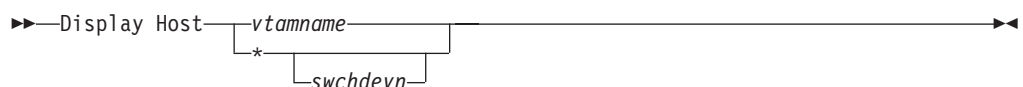

### Parameters

*vtamname* | \*

Specifies one or all I/O operations hosts known to the issuing I/O operations.

*vtamname*

Specifies an I/O operations by its VTAM application name (VTAM ID). If the issuing I/O operations has no valid VTAM application name, the VTAM name is not available, or VTAM is not available, you can specify THIS-SYS for the issuing I/O operations

**\* (asterisk)**

Specifies all the I/O operations known to the issuing I/O operations.

For a discussion, see “Switching Commands” on page 348.

*swchdevn*

Specifies one switch allocated to the issuing I/O operations. If you do not

## DISPLAY HOST

specify a switch device number, the issuing I/O operations displays status about all its participating hosts. For a discussion, see “Switch Identifiers” on page 333.

### Usage

- See the following example for the type of data displayed.
- If the DISPLAY RESULTS, LOGREC, SYNC SWITCH, or WRITE command is entered, the data that could be displayed by DISPLAY HOST is refreshed.
- For more information on the displayed output, see the page reference under the fields:

```
IHVC803I THIS HOST: vtamname
IHVC804I VTAMNAME LEVEL PHYSICAL IDENTIFIER      SYSPLEX SYSTEM
A           B
```

- A** Message
- B** VTAM name (see “VTAM Application Name” on page 350)

```
IHVC805I THE FOLLOWING SWCHS ARE ATTACHED:
IHVC806I SWCH
IHVC807I DEVN LSN UNIQUE ID
A           B   C   D
```

- A** Message
- B** Switch device number (see “Switch Identifiers” on page 333)
- C** Logical switch number (see “Logical Switch Number (LSN)” on page 334)
- D** Switch ID number (see “Switch Unique Identifier” on page 348)

### Examples

```
D H IHVAPPLA
IHVC803I THIS HOST: IHVAPPLA  SYSPLEX: SYSPLEX1  SYSTEM: SYSTEM12
IHVC804I VTAMNAME LEVEL PHYSICAL IDENTIFIER      SYSPLEX SYSTEM
IHVC80CI IHVAPPLA V1 R3 00309020JIBM00000000070054  SYSPLEX1 SYSTEM12
IHVC537I VTAM communication is initialized on this host
IHVC805I THE FOLLOWING SWCHS ARE ATTACHED:
IHVC806I SWCH
IHVC807I DEVN LSN UNIQUE ID
IHVC80AI 0100 01 009032002IBM01000000034893
IHVC80AI 0200 02 009032002IBM02000000093622
```

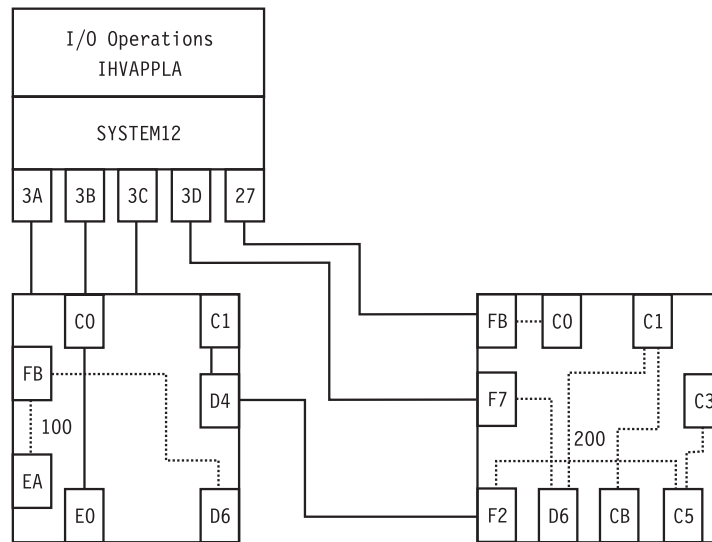

Figure 117. DISPLAY HOST Command - Sample 1

```

D H *
IHVC803I THIS HOST: IHVAPPLA  SYSPLEX: SYSPLEX1  SYSTEM: SYSTEM12
IHVC804I VTAMNAME  LEVEL PHYSICAL IDENTIFIER      SYSPLEX SYSTEM
IHVC80CI IHVAPPLA  V1 R3 00309020JIBM00000000070054 SYSPLEX1 SYSTEM12
IHVC537I          VTAM communication is initialized on this host
IHVC80CI IHVAPPLB  V1 R3 003090000IBM01000138586566 SYSPLEX1 SYSTEM13
IHVC535I          VTAM session established with this host
IHVC884I Sysplex systems not associated with a VTAM name detected:
IHVC885I SYSPLEX  SYSTEMS-----|
IHVC886I SYSPLEX1 SYSTEM14,      ,      ,      ,
    
```

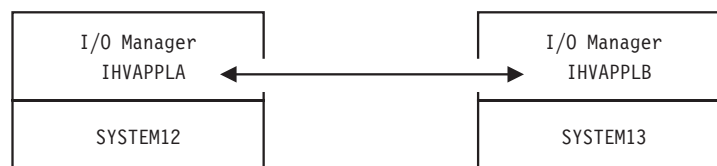

Figure 118. DISPLAY HOST Command - Sample 2

## DISPLAY NAME

### Purpose

Use the DISPLAY NAME command to display data about the implemented ports on a switch to which port names have been assigned. (See "WRITE" on page 257 for the command used to assign port names.)

## DISPLAY NAME

### Syntax

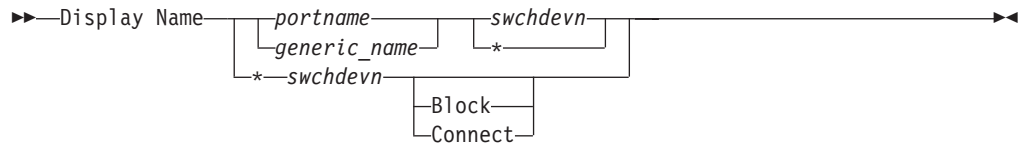

### Parameters

**portname | generic\_name | \***

Specifies that data be displayed about a specifically named port, all ports with the specified generic logical port name, or all named addressable ports (\* not enclosed in parentheses). If you specify \* in this operand, you cannot specify \* in the next operand, but you can specify Block or Connect as options. For a discussion, see “Port Switching Commands” on page 345.

**swchdevn | \***

Specifies one switch or all switches (\* not enclosed in parentheses) allocated to the issuing I/O operations. If you specify \*, you must specify either an individual or a generic port name, but not all port names. For a discussion, see “Switch Identifiers” on page 333.

### Options

**Block | Connect**

Specifies that data be displayed only about those named ports that are blocked or statically connected to another port. If you specify this option, you must also specify \* for all port names.

### Usage

For more information on the displayed output, see the page references under the fields.

		SWCH		PORT		PORT STATUS		I/O	
		DEVN	LSN	PORT	H	S	C	P	DEF
IHVC844I									
IHVC845I									
IHVC846I	PORT NAME								
<b>A</b>	<b>B</b>	<b>C</b>	<b>D</b>	<b>E</b>	<b>F</b>	<b>F</b>	<b>G</b>		

- A** Message
- B** Port name (see “Using Port Names as a Tool in Switching Commands” on page 343)
- C** Switch device number (see “Switch Identifiers” on page 333)
- D** Logical switch number (see “Logical Switch Number (LSN)” on page 334)
- E** Port address (see “Port Addresses” on page 348)
- F** Port status codes (see “Switch Port Hardware Status on a Display Command” on page 344)
- G** I/O definition (see “Switch Ports” on page 342)

## Examples

```

D N * 100
IHVC844I
IHVC845I
IHVC846I PORT NAME          SWCH      LSN      PORT      H S C P DEF
IHVC847I HA.CHP.88.CVC      0100    01      C0        E0 P CH
IHVC847I HA.CHP.3C         0100    01      C1        D4 P
IHVC847I LINK.200          0100    01      D4        C  C1 P
IHVC847I CU.F00            0100    01      D6        P CU
IHVC847I CU.B20.9034       0100    01      E0        C0 P CU
IHVC847I CU.190            0100    01      EA        P CU
IHVC847I HA.CHP.3A         0100    01      FB        P CH
    
```

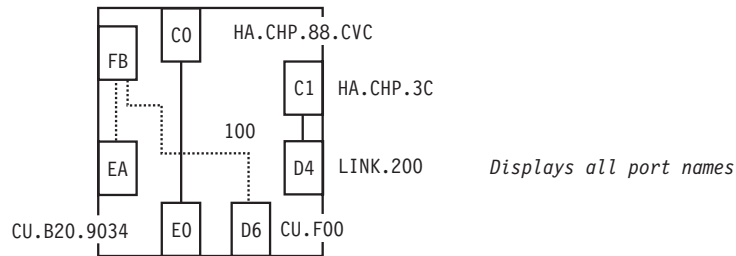

Figure 119. DISPLAY NAME Command - Sample 1

```

D N CU.F00 *
IHVC844I
IHVC845I
IHVC846I PORT NAME          SWCH      LSN      PORT      H S C P DEF
IHVC847I CU.F00            0100    01      D6        P CU
IHVC847I CU.F00            0200    02      D6        CU
    
```

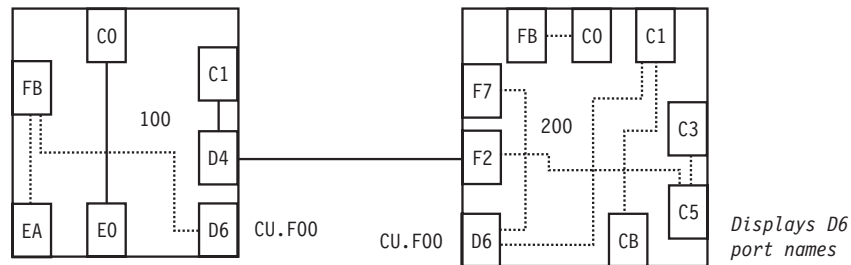

Figure 120. DISPLAY NAME Command - Sample 2

## DISPLAY PORT

### Purpose

Use the DISPLAY PORT command to display data about one or all the ports that are implemented and installed on the specified switch.

### Syntax



## Examples

```

D P (D6) 100
IHVC844I
IHVC845I                                PORT
IHVC846I PORT NAME                      SWCH  STATUS I/O
IHVC847I CU.F00                          0100  01    D6  H S C P DEF
                                           P CU

IHVC849I ALLOW/PROHIBIT MASK FOR THIS PORT:
IHVC84AI  A/P  PORT  PORT NAME          I/O DEF
IHVC84BI  A    C0   HA.CHP_88.CVC      CH
IHVC84BI  P    C1   HA.CHP_3C          CH
IHVC84BI  A    C2
IHVC84BI  A    C3
IHVC84BI  A    C4
:
IHVC84BI  A    FB   HA.CHP_3A          CH
IHVC84BI  A    FE
    
```

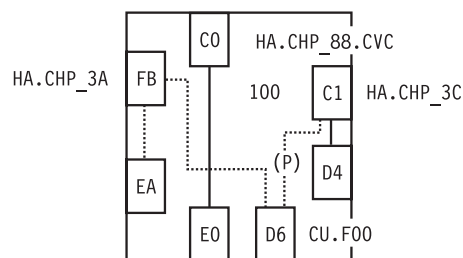

Figure 121. DISPLAY PORT Command - Sample

## DISPLAY RESULTS

### Purpose

Use the DISPLAY RESULTS command to display the results of the issuing I/O operations' most recently processed connectivity (except REMOVE and RESTORE Dev), LOGREC, SYNC SWITCH, or WRITE command. Especially in cases in which one or more vary path requests failed, the DISPLAY RESULTS command is a useful tool to help you analyze the resulting configuration status.

For related commands, see "DISPLAY HOST" on page 225 and "DISPLAY VARY" on page 236.

### Syntax

►►—Display Results—◄◄

### Usage

- In addition to displaying data about its most recently processed connectivity command (except Remove and Restore Dev), the issuing I/O operations displays any subsequent command up to the next connectivity, Logrec, Sync Switch, or Write command.
- To review any additional failed vary path requests resulting from the same command, use the "DISPLAY VARY" on page 236.

## DISPLAY RESULTS

- For more information on the displayed output fields, see the page references under the fields:

```

IHVC803I THIS HOST: vtamname  SYSPLEX:          SYSTEM:
IHVC808I VTAMNAME
IHVC808I vtamname1
IHVC505I   No failures detected by this host
IHVC808I VTAMNAME
IHVC808I vtamname2
IHVC525I   This host has been RESET off
IHVC500I SWCH DEVN LSN UNIQUE ID                STATUS      CODE
A       B       C       D

```

- A** Message
- B** Switch device number (see "Switch Identifiers" on page 333)
- C** Logical switch number (see "Logical Switch Number (LSN)" on page 334)
- D** Unique identifier (see "Switch Unique Identifier" on page 348)

## Examples

### Example 1

As shown in the figure below, a chain has been defined, so that ports *CB* and *D6* are statically connected on the pass-thru switch 200.

A user entered *N (D6) (CB) 200* and the command failed.

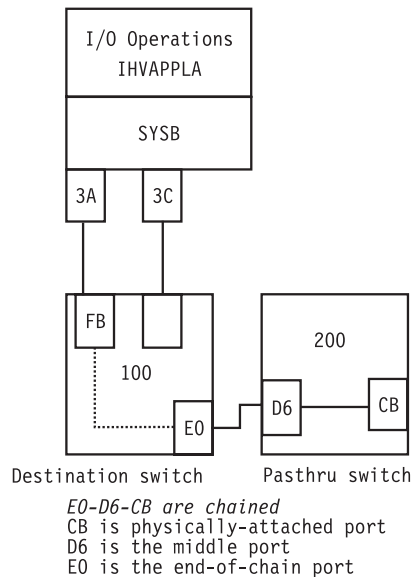

Figure 122. DISPLAY RESULTS Command - Scenario 1.

The user then entered the DISPLAY RESULTS command to analyze the cause of failure.

## DISPLAY RESULTS

```

D R
IHVC803I THIS HOST: IHVAPPLA  SYSPLEX: SYSPLEX1  SYSTEM: SYSTEM12
IHVC808I VTAMNAME  SYSPLEX  SYSTEM
IHVC80BI IHVAPPLA  SYSPLEX1  SYSTEM66
IHVC505I   No failures detected by this host
IHVC808I VTAMNAME  SYSPLEX  SYSTEM
IHVC80BI IHVAPPLB  SYSPLEX1  SYSTEM22
IHVC505I   No failures detected by this host
IHVC500I SWCH DEVN LSN UNIQUE ID                STATUS      CODE
IHVC501I  0100  01  009032002IBM01000000034893 OPERATIONAL  00
IHVC520I   Command not sent to this SWCH
IHVC500I SWCH DEVN LSN UNIQUE ID                STATUS      CODE
IHVC501I  0200  02  009032002IBM02000000093622 OPERATIONAL  00
IHVC906I   Cannot DISCONNECT CHAINED port D6
IHVC906I   Cannot DISCONNECT CHAINED port CB
  
```

### Example 2

The user tried to Block (C3) 200 NOF.

The command fails because an operational CV converter is attached to port C3.

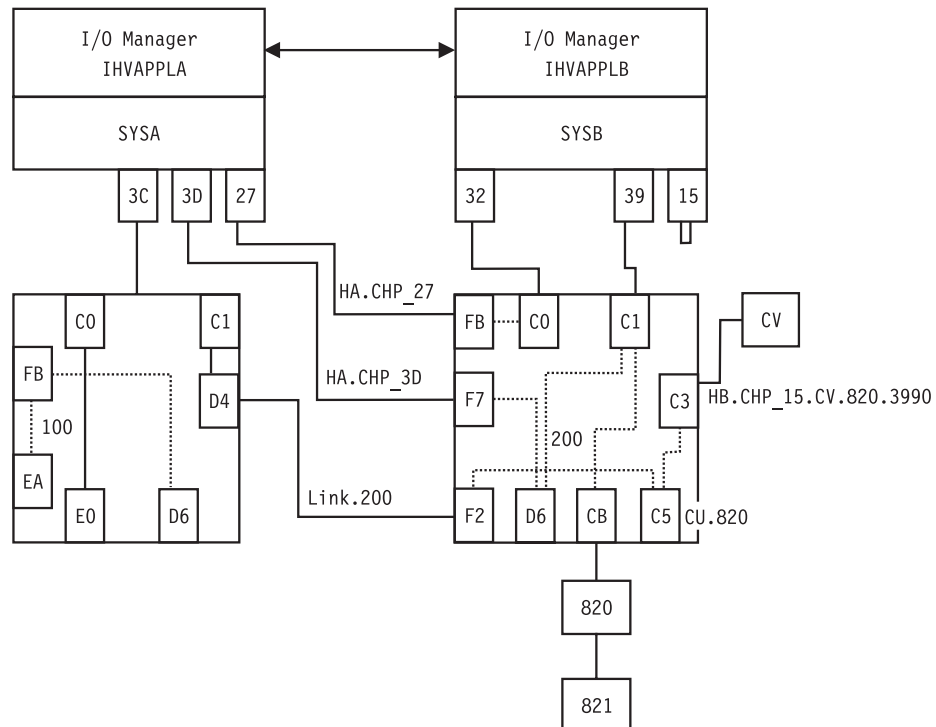

Figure 123. DISPLAY RESULTS Command - Scenario 2

The user entered the DISPLAY RESULTS command to analyze the cause of failure.

## DISPLAY RESULTS

```

D R
IHVC999I I/O operations display
IHVC808I VTAMNAME      SYSPLEX  SYSTEM
IHVC808I IHVAPPLA     SYSPLEX1  SYSTEM66
IHVC621I  ESCON Converter Model 2(s) detected
IHVC808I VTAMNAME      SYSPLEX  SYSTEM
IHVC808I IHVAPPLB     SYSPLEX1  SYSTEM22
IHVC505I  No failures detected by this host
IHVC500I SWCH DEVN LSN UNIQUE ID                STATUS      CODE
IHVC501I  0100  01  009032002IBM01000000034893 OPERATIONAL  00
IHVC520I  Command not sent to this SWCH
IHVC500I SWCH DEVN LSN UNIQUE ID                STATUS      CODE
IHVC501I  0200  02  009032002IBM02000000093622 OPERATIONAL  00
IHVC622I  ESCON Converter Model 2 paths may require DISABLEMENT:
IHVC623I  ID TYPE MOD SERIAL NUMBR PORT LOGICAL NAME / UNIQUE ID
IHVC626I  CU 003990 G03 000000090046  C5 CU.820
IHVC627I  CV 009035 002 000000020466  C3 HB.CHP_15.CV.820.3990
  
```

## DISPLAY SWITCH

### Purpose

Use the DISPLAY SWITCH command to display data about one or about all the switches allocated to the issuing I/O operations.

### Syntax

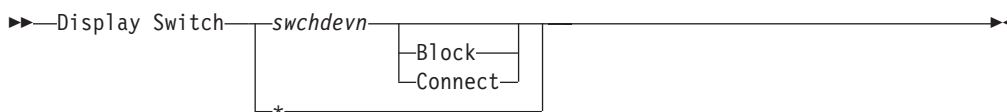

### Parameters

**swchdevn | \***

Specifies one switch or all switches (\* not enclosed in parentheses) allocated to the issuing I/O operations. For a discussion, see “Switch Identifiers” on page 333.

### Options

**Block | Connect**

Specifies that you want data displayed about only those ports that are blocked or are part of a static connection. (If a port is both blocked and statically connected, it is listed if either parameter is chosen.) You can enter this optional parameter only if you also specified an individual switch device number.

### Usage

For more information on the displayed output, see the page references under the fields:

IHVC833I SWCH				PORTS	SWCH	STATUS
IHVC834I DEVN LSN UNIQUE ID				INSTALLED	STATUS	CODE
<b>A</b>	<b>B</b>	<b>C</b>	<b>D</b>	<b>E</b>		

- A** Message
- B** Switch device number (see “Switch Identifiers” on page 333)
- C** Logical switch number (see “Logical Switch Number (LSN)” on page 334)

## DISPLAY SWITCH

- D** Unique identifier (see “Switch Unique Identifier” on page 348)
- E** Installed ports (see 333)

IHVC835I	PORT	PORT STATUS	H S C P	PORT NAME	I/O DEF
IHVC836I					
IHVC837I					

- A** Message
- B** Port number (see “Port Addresses” on page 348)
- C** Port status code (see “Switch Port Hardware Status on a Display Command” on page 344)
- D** Port name (see “Using Port Names as a Tool in Switching Commands” on page 343)
- E** I/O definition (see “Switch Ports” on page 342)

## Examples

```

D S 100
IHVC833I SWCH
IHVC834I DEVN LSN UNIQUE ID          PORTS SWCH STATUS
IHVC838I 0100 01 009032002IBM01000000034893 61 OPERATIONAL 00
IHVC835I          PORT
IHVC836I          STATUS
IHVC837I          PORT H S C P      PORT NAME      I/O DEF
IHVC839I          C0      E0 P      HA.CHP_88.CVC CH
IHVC839I          C1      D4 P      HA.CHP_3C    CH
IHVC839I          C2      P
IHVC839I          C3      P
IHVC839I          C4      P
:
IHVC839I          D4      C1 P      LINK.200    CU
:
IHVC839I          FB      P      HA.CHP_3A    CH
IHVC839I          FE
  
```

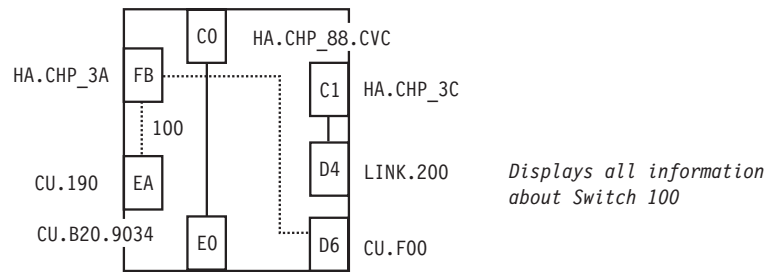

*Displays all information about Switch 100*

Figure 124. DISPLAY SWITCH Command - Sample 1

```

D S *
IHVC833I SWCH
IHVC834I DEVN LSN UNIQUE ID          PORTS SWCH STATUS
IHVC838I 0100 01 009032002IBM01000000034893 61 OPERATIONAL 00
IHVC838I 0200 02 009032002IBM02000000093622 61 OPERATIONAL 00
IHVC838I 0400 04                                0 NOT OPEN 1C
  
```

## DISPLAY TIMEOUT

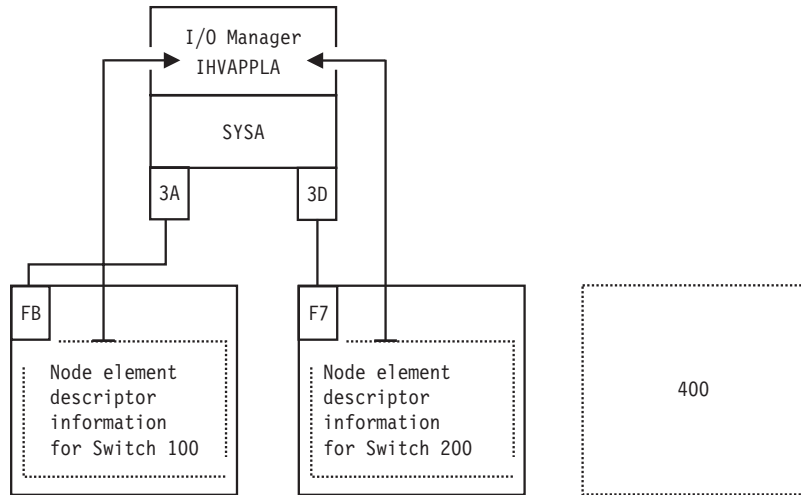

Figure 125. DISPLAY SWITCH Command - Sample 2

---

## DISPLAY TIMEOUT

### Purpose

Use the DISPLAY TIMEOUT command to display the maximum number of seconds that the issuing I/O operations will wait to receive votes from the I/O operations that form its voting constituency and that have not been reset off with the command described under “RESET HOST” on page 245. If one or more votes is still outstanding when the time interval lapses, the issuing I/O operations declares a negative consensus.

### Syntax

►►—Display Timeout—◄◄

### Examples

```
D T  
IHVC860I Current timeout value is 60 seconds
```

---

## DISPLAY VARY

### Purpose

Use the DISPLAY VARY command to display a specified number (up to 1500) failed vary path requests that have resulted either from the issuing I/O operations’s most recently processed connectivity command or that were built with the Sync Switch command.

The data displayed depends on the type of command that failed and the options that you specify on the Display Vary command.

See “DISPLAY HOST” on page 225 and “DISPLAY RESULTS” on page 231 for related commands, and “Processing a Vary Path Request” on page 349 for more information.

## Syntax

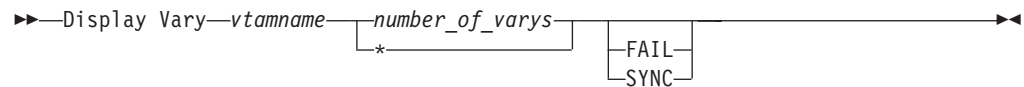

## Parameters

### vtamname

Specifies the participating I/O operations by its VTAM application ID. The failed vary requests will be listed in the output for that I/O operations (host), but only for a command that was initiated by the issuing I/O operations.

### number\_of\_varys | \*

Replace *number\_of\_varys* with a decimal integer from 1 through 1500. The asterisk (\*) specifies all (up to the maximum of 1500). The number of failed vary path requests displayed is independent from similar data displayed by other commands. For example, if you had already displayed three vary path requests using the Display Vary command and want to display 15 *additional* vary path requests with the Display Vary command, specify 18 vary path requests.

## Options

### SYNC

Specifies that the vary path requests built with the Sync Switch command be displayed.

### FAIL

Specifies only the failed vary path requests (if any), or Varies from a connectivity command be displayed.

## Usage

- Failed vary path requests listed in this command relate to the path from a CHPID to a device.
- If a vary path request fails, the path through the port or ports specified in the connectivity command could not be brought offline or online, depending on the command that was entered.

## Examples

```

D V IHVAPPLA 90
IHVC999I I/O operations display

IHVC811I VARY TYPE   TRIED   FAILED 1ST   90 FAILURES (DEV,CHP)
IHVC819I OFFLINE      5       3 (0190,3A)(019E,3A)(019D,3A)( , )

IHVC81FI BACKOUT     2       0 ( , )( , )( , )( , )

IHVC83CI CONFIG TYPE TRIED   FAILED 1ST   90 FAILURES (CHP)
IHVC879I No failed CONFIGs on previous command
IHVC872I SYNC TYPE   NUMBER   1ST   90 VARYS (DEV,CHP)
IHVC875I No SYNC VARYs detected on previous command
IHVC853I CONFIG TYPE   NUMBER   1ST   90 CONFIGs (CHP)
IHVC877I No SYNC Configs detected on previous command
  
```

---

## GETLOCK

### Purpose

Use the GETLOCK command to obtain the processing lock for a user ID that enters a command to any instance of I/O operations within the same set of I/O operations. (A set of I/O operations incorporates all the base programs that can participate in consensus processing of a connectivity command initiated by the issuing instance of I/O operations and those that can communicate with one of these participants via VTAM.)

See “UNLOCK” on page 256 for the reciprocal command.

### Syntax

▶▶—GETLOCK—◀◀

### Usage

- The GETLOCK command is used when a user wants to perform a series of I/O operation commands without interruption.
- You may need to enter the GETLOCK command if another user ID has the lock and will not, or cannot, release it. Such a situation could arise, for example, if the other user’s terminal is inactive.
- Note that default conditions for obtaining the processing lock are provided with the I/O operations Workstation feature and the sample ISPF dialog. You can accept these defaults or customize them for your ISPF user ID or for entries at the workstation.
- The GETLOCK command takes control of I/O operations processing and can, therefore, potentially interrupt a series of connectivity commands being entered by another user ID with unpredictable results.
- If your user ID has control authorization required to enter the Getlock command, be sure you have considered all pertinent aspects of the system I/O environment before issuing this command.
- Note that you can release the lock with the Unlock command and should, of course, do so when you are finished entering I/O operations commands for the session.

### Examples

```
GETLOCK  
IHVC0001 GETLOCK    command successful
```

---

## LOGREC

### Purpose

Use the LOGREC command to have I/O operations instruct the specified switch or switches to send their log data to the host (system control program) on which the issuing I/O operations is running.

## Syntax



## Parameters

`swchdevn | *`

Specifies one switch or all the switches (\* not enclosed in parentheses) allocated to the issuing I/O operations. For a discussion, see “Switch Identifiers” on page 333.

## Usage

- The LOGREC command remains in effect across I/O operations sessions, unless the host image becomes dysfunctional.
- If you enter the LOGREC command, it is advisable to do so when the I/O operations base program is started.
- The LOGREC command causes any data that I/O operations has accumulated for display with the DISPLAY RESULTS command to be refreshed.

## Examples

```
LOGREC 100
IHVC000I LOGREC      command successful
```

---

## PROHIBIT

### Purpose

Use the PROHIBIT command to prevent data transfer between ports on the same switch or on all switches allocated to the issuing I/O operations.

Unlike the BLOCK command, the PROHIBIT command allows the two ports to have dynamic connections with other ports. You can prohibit data transfer between ports according to the following syntax diagram. See “ALLOW” on page 212 for the reciprocal command.

### Syntax

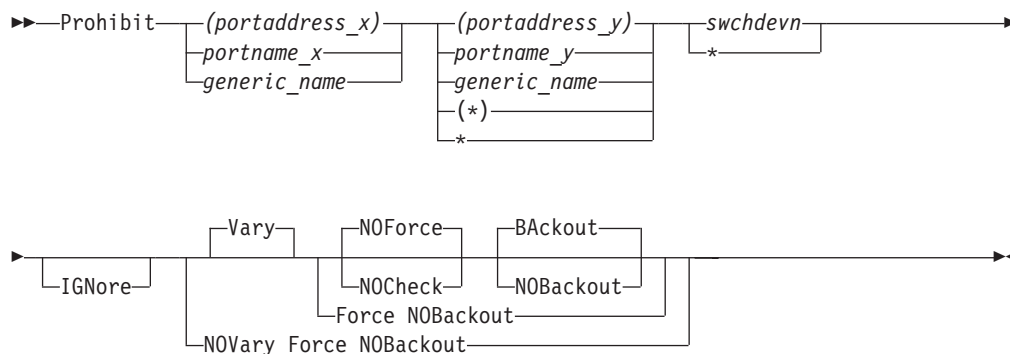

## PROHIBIT

### Parameters

**(portaddress\_x) | portname\_x | generic\_name**

Specifies the port to be prohibited by its port address (enclosed in parentheses), by its individual port name, or by a generic port name. For a discussion, see “Port Switching Commands” on page 345.

**(portaddress\_y) | portname\_y | generic\_name | (\*) | \***

Specifies the other ports in one of the following ways: a port address (enclosed in parentheses), an individual port name, a generic port name, all other port addresses (\* enclosed in parentheses), or all other port names (\* not enclosed in parentheses). For a discussion, see “Port Switching Commands” on page 345.

**swchdevn | \***

Specifies one switch or all the switches (\* not enclosed in parentheses) allocated to the issuing I/O operations. For a discussion, see “Switch Identifiers” on page 333.

### Options

**IGNore**

You must specify this option when an Inter-Switch-Link port (E\_Port) is involved. Otherwise the command is rejected with return code 8 and reason code X'49'. The reason is I/O operations can no longer guarantee “safe-switching” when an E\_Port is involved.

“Safe-switching” sets the paths and devices online or offline when the path from a chpid to a device either becomes valid or is no longer valid because of a port manipulation.

**Connectivity options**

For a discussion on Vary | NOVary, NOForce | NOCheck | Force, and BAckout | NOBackout see “Making Connectivity Changes” on page 340.

### Usage

- If you specify an individual or generic port name, all the switches involved must have at least one port implemented with an applicable port name.
- If a parallel channel path and CV converter are involved, consider the information in “A Parallel Channel in Block (BL) Mode” on page 347.

### Examples

```
P (FB) (D6) 100  
IHVC000I PROHIBIT command successful
```

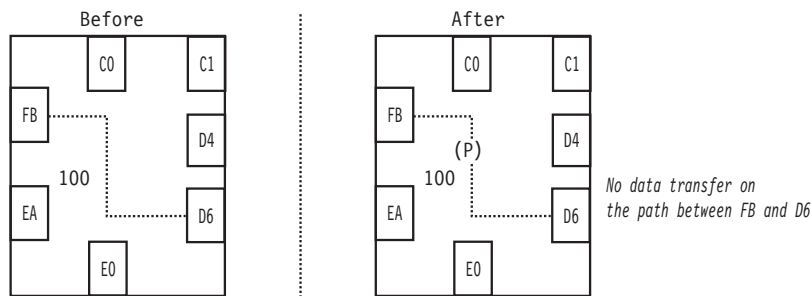

Figure 126. PROHIBIT Command - Sample 1

```
P HB.CHP_39 CU.* 200
IHVC000I PROHIBIT command successful
```

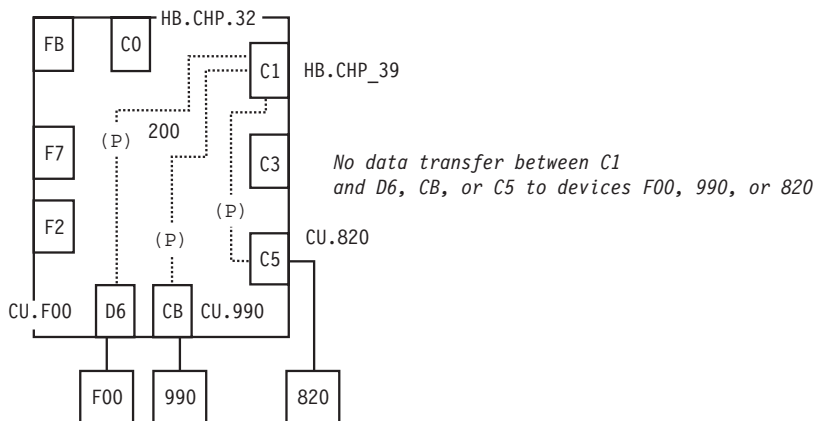

Figure 127. PROHIBIT Command - Sample 2

## REMOVE CHP

### Purpose

Use the REMOVE CHP command to configure the specified CHPID offline to the host image of the target I/O operations in the command. See “RESTORE CHP” on page 249 for information on the reciprocal command.

### Syntax

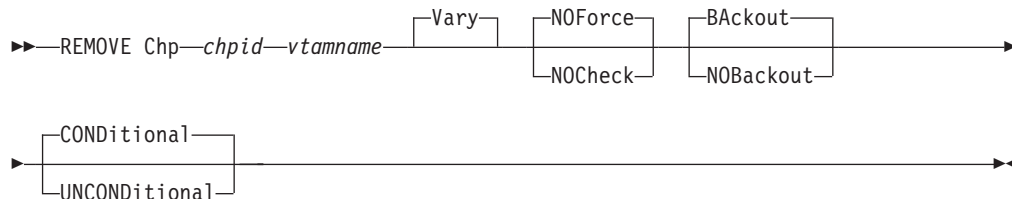

## REMOVE CHP

### Parameters

*chpid*

Specify the CHPID as a hexadecimal number in the range X'00—FF'.

*vtamname*

Specify the VTAM application name of the target I/O operations.

The target I/O operations is the program that instructs its host image to configure the specified CHPID offline.

The target system can be any I/O operations host to which a VTAM session is established.

You can specify THIS-SYS in uppercase characters if the issuing I/O operations is the target program and if any of the following conditions holds:

- The issuing I/O operation does not have a valid VTAM name.
- The issuing I/O operations' VTAM name is not available.
- VTAM is not available.

To review a list of applicable VTAM names, you can use the Display Host command. If you enter D H \*, you can determine whether the issuing I/O operations calls itself THIS-SYS.

### Options

**VARY**

**VARY** is the default and **NOVary** is *not* an alternative.

I/O operations issues the appropriate vary path-offline requests for all the paths that have been defined to the specified CHPID in the relevant host I/O Control Data Set (IOCDS).

Only after all these paths have been varied offline does the target I/O operations request the target host image to configure the specified CHPID offline.

**NOForce | NOCheck**

**NOForce** is the default. Although you can specify **NOCheck**, that alternative has no additional effect in this command.

**BAckout | NOBackout**

If you specify **BAckout**, I/O operations attempts to vary those paths back online that had been varied offline successfully if either:

- At least one vary path-offline request failed.
- All the vary path requests were successful, but the program could not configure the CHPID offline.

**CONDitional**

This is the default option for both the **REMOVE CHP** and **RESTORE CHP** commands. It indicates that no special configure offline or configure online action should be performed.

**UNCONDitional**

For the **REMOVE CHP** command, this option puts the specified chpids immediately into pending offline status, even if the chpids are currently active, allocated, or reserved.

For the **RESTORE CHP** command, this option brings the specified chpids online, even if there are no paths to the chpids, or if the chpids are pending offline and boxed.

## Usage

- The CHPID type must be known to the target I/O operations.
- If the REMOVE CHP command causes one or more devices to be removed from the host image on which the target I/O operations is running, I/O operations automatically attempts to delete these devices from its internal configuration map.
- I/O operations does not attempt to configure the channel offline if any of the relevant vary path requests failed.
- I/O operations does not attempt to configure the channel offline if the target I/O operations is reset off or purged from intersystem communication.
- If the target I/O operations is running in an MVS environment and if the program timed out with the state of the CHPID unknown, I/O operations attempts to configure the channel back online.
- If you are considering specifying a CVC channel for this command, note that SA OS/390 automatically configures a CVC CHPID offline when it processes any of the the following commands for a path defined with that CHPID: BLOCK, DISCONNECT, REMOVE SWITCH, and UNCHAIN.
- The command is not supported if the target I/O operations is running on a host system that is operating as a guest in a VM environment.

---

## REMOVE SWITCH

### Purpose

Use the REMOVE SWITCH command to vary all logical paths through the specified switch offline and, optionally, to disable the unit.

The switch must be allocated to the issuing I/O operations. See “RESTORE SWITCH” on page 251 for the reciprocal command, and “Remove (Quiesce) a Switch” on page 344 for discussion.

### Syntax

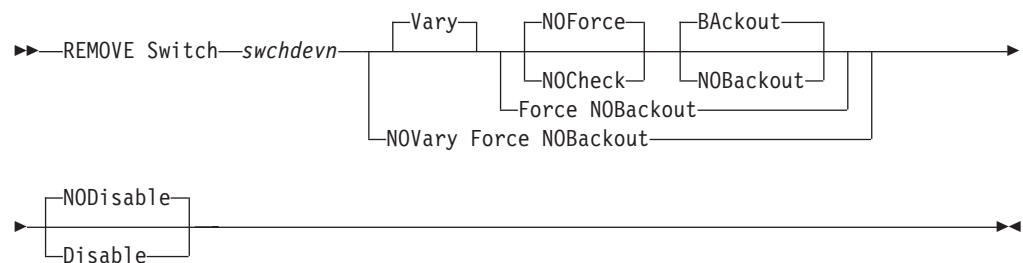

### Parameters

#### swchdevn

Specifies the switch to be varied offline and optionally to be disabled. The switch must be allocated to the issuing I/O operations. For a discussion, see “Switch Identifiers” on page 333.

## REMOVE SWITCH

### Options

#### NODisable | Disable

**NODisable** (default) specifies that every path that passes through the switch is varied offline. (The path to the control unit port, or CUP, is not varied offline.) The switch is not deallocated, or detached, from I/O operations.

**Disable** specifies that every path that passes through the switch is varied offline. (The path to the control unit port, or CUP, is not varied offline.) The switch is then deallocated, or detached, from I/O operations.

#### Connectivity options

For a discussion on Vary | NOVary, NOForce | NOCheck | Force, and BAckout | NOBackout see “Making Connectivity Changes” on page 340.

### Usage

- If a path through the switch is chained and you intend to remove the switch, physically cancel the definition of the chain first.
- If you specify the Disable option, power to the switch must be turned off and then on before communications can be restored to the unit. See “RESTORE SWITCH” on page 251.

#### Attention:

Issuing the REMOVE Switch command with the Disable option will switch power off to the IBM 9032 Model 2 ESCON® Director but will just cycle the power (power stays switched on) for the IBM 9032 Model 3 ESCON Director.

- If you specify the Disable option, and if you plan to restore what is physically the same switch using the RESTORE S command later, do not change the switch device offline to MVS or OS/390. However, if you are planning to restore a physically different switch, for example, when replacing a 9032-003 ESCON Director with a 9032-005 ESCON Director, then the correct sequence of operations is as follows:
  1. Issue REMOVE S.
  2. Change the switch device offline to the operation system.
  3. Perform the physical replacement of the switch.
  4. Change the switch online to the operating system.
  5. Then issue RESTORE S.

SA OS/390's REMOVE DEVICE and RESTORE DEVICE can be used to vary the device offline or online to multiple systems as one operation. For further information, refer to the description of “REMOVE and RESTORE DEV (API)” in *System Automation for OS/390 Programmer's Reference*.

- If the command fails, display pathing status with “DISPLAY HOST” on page 225, “DISPLAY RESULTS” on page 231, or “DISPLAY VARY” on page 236. Consider rerunning the command with the Force and Disable options.

### Examples

```
REMOVE S 200 D  
IHVC0001 REMOVE      command successful
```

## RESET HOST

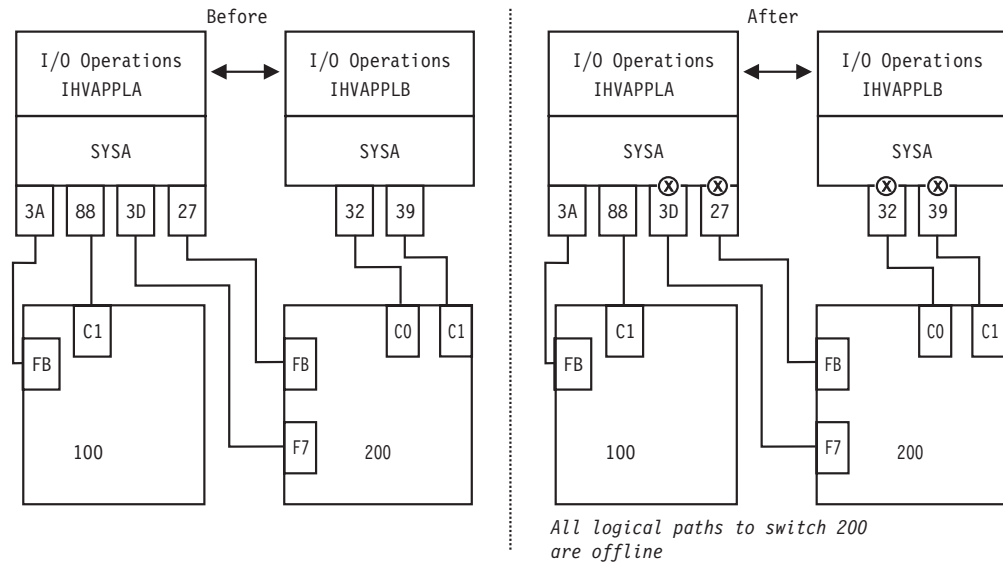

Figure 128. REMOVE SWITCH Command - Sample.

## RESET HOST

### Purpose

Use the RESET HOST command to include or exclude any participant in the issuing I/O operations's consensus processing.

With this command, you can avoid having the issuing I/O operations stop the command from completing because, for example, a participant could not return a vote.

See "DISPLAY HOST" on page 225 for the related command.

### Syntax

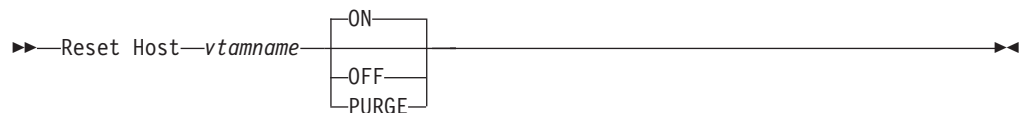

### Parameters

*vtamname*

Specifies the VTAM application name, or VTAM ID, of the I/O operations targeted in the command.

When I/O operations is started, it writes its VTAM ID to all the switches allocated to it. Should the I/O configuration have no or restricted use of switches, dynamic communication between I/O operations may not be achieved, in which case, the RESET HOST command is used. The RESET HOST command allows an operator or automated program to declare the VTAM IDs of peers to I/O operations. I/O operations participating in consensus processing use these VTAM IDs to communicate with each other.

## RESET HOST

### ON

Is the default. It specifies that the issuing I/O operations will include the target I/O operations in its consensus processing. (The issuing I/O operations can include itself.) Should the VTAM ID not be recognized, I/O operations records the name and attempts to establish a communication session with the peer. The new peer is included in all subsequent consensus processing.

### OFF

Specifies that the issuing I/O operations will exclude the target I/O operations in consensus processing. (The issuing I/O operations can exclude itself.)

### PURGE

Specifies that the issuing I/O operations will exclude the targeted I/O operations from participating in its consensus processing until the target host re-registers its VTAM name when it sends a command to one of the switches allocated to both the purged I/O operations and the I/O operations that issued the purge, when the purged I/O operations is restarted, or when a RESET HOST command with the ON operand is issued. Use this option to exclude systems that have ended abnormally or when an incorrect VTAM ID was entered using the RESET HOST command with the ON operand. (The issuing I/O operations cannot purge itself.)

## Usage

The RESET HOST command affects an I/O operations's participation only in consensus processing initiated by the issuing I/O operations. It does not affect consensus vary path processing initiated by any other I/O operations, including a broadcast initiated by a host that has been reset off.

When the VTAM ID is not known command processing for RESET HOST *vtamname* ON is as follows:

1. The VTAM ID is recorded by the I/O operations and is included in subsequent consensus processing. Should the name not be successfully recorded the following messages are issued:

```
IHVC002I Reset command failed. RC = 8 Reas= 5000000A  
IHVC401I Host(s) unable to process the RESET command
```

2. An attempt to establish a VTAM session is made. If the session is successfully established with the peer its VTAM ID name is automatically passed to other I/O operations in the domain. Then each I/O operations dynamically establishes its own session to the peer. The following message is issued:

```
IHVC000I RESET command successful
```

3. If the VTAM session is not successfully established the VTAM ID is retained by I/O operations, but the name is not broadcast to other peers. This can be caused, for example, by the specification of an incorrect VTAM ID. Should this occur the following messages are issued:

```
IHVC001I Reset command successful. RC = 4 Reas= 5000000A  
IHVC401I Host(s) unable to process the RESET command
```

Additional information is presented in the Display Results output that indicates the VTAM session was not established.

## Examples

```
R H IHVAPPLB OFF  
IHVC000I RESET      command successful
```

```
R H IHVAPPLB ON
IHVC000I RESET      command successful
```

```
R H IHVAPPLB PURGE
IHVC000I RESET      command successful
```

**Examples of Using RESET HOST to Declare Peer I/O Operations**

*No Switch Configuration:*

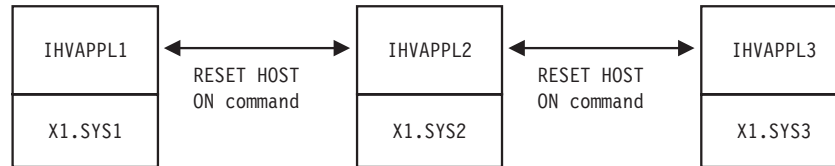

Figure 129. RESET HOST Command - Scenario 1

In the above figure all three I/O operations start without the knowledge of their peers. To establish communication among them, two RESET HOST commands are required, issued on any of the I/O operations. For example, on IHVAPPL1, the following commands are issued:

```
R H IHVAPPL2 ON
IHVC000I RESET      command successful
R H IHVAPPL3 ON
IHVC000I RESET      command successful
```

This results in all I/O operations establishing a communication session between them.

*Restricted Switch Configuration:*

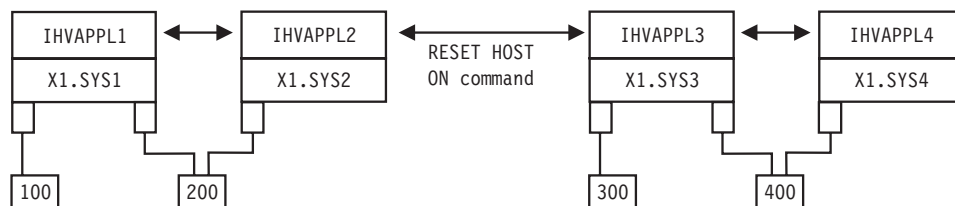

Figure 130. RESET HOST Command - Scenario 2

In the above figure, I/O operations IHVAPPL1 and IHVAPPL2 dynamically establish a session with one another at startup. IHVAPPL3 and IHVAPPL4 do so as well. However, neither group knows about the other due to a lack of a switch attachment. To establish communication among the two groups, only a single RESET HOST command is required and may be issued on any of the I/O operations. For example, on IHVAPPL1, the following command is issued:

```
R H IHVAPPL4 ON
IHVC000I RESET      command successful
```

## RESET HOST

This results in all I/O operations establishing a communication session between themselves.

---

## RESET SWITCH

### Purpose

Use the RESET SWITCH command to update the issuing I/O operations' configuration map about a single switch or all the switches that are allocated to it.

### Syntax

```
▶▶—Reset Switch—swchdevn—▶▶  
                  *—
```

### Parameters

**swchdevn | \***

Specifies one switch or all switches (\* not enclosed in parentheses) allocated to the issuing I/O operations.

For a discussion, see “Switch Identifiers” on page 333.

### Usage

- If you specify R S \*, thus resetting all the switches, the issuing I/O operations tries to allocate, or attach, all the switches defined to its host image. In this way, you can provide access to a new switch device number to the issuing I/O operations.
- Make sure you enter this command when you add or modify a switch allocated to the issuing I/O operations during operations.

### Examples

```
R S 100  
IHVC000I RESET       command successful
```

The following data is updated:

- The VTAM application names of the I/O operations that participate in consensus vary-path processing initiated by the issuing ESCON Manger.
- Switch device number. (See “Switch Identifiers” on page 333.)
- Port names and port attributes. (See “Port Switching Commands” on page 345.)
- Chaining information.

---

## RESET TIMEOUT

### Purpose

Use the RESET TIMEOUT command to specify the limit of the time interval –in seconds– that any participating I/O operations will wait for votes to be returned when it broadcasts as the issuing I/O operations.

## Syntax



## Parameters

**seconds** | \*

Specifies the number of seconds from 0 up to and including 999,999 or the IBM-supplied default of 60 seconds (\* not in parentheses).

## Usage

- If the issuing I/O operations receives responses from all eligible voters (all voters except any that have been reset off by the issuing I/O operations) before the time limit is reached, and if all the votes are affirmative, command processing continues.

Unless the command is being forced, either a negative vote or a failure to respond within the time limit causes the issuing I/O operations to fail the command.

## Examples

```
R T 120
IHVC000I RESET      command successful
```

## RESTORE CHP

### Purpose

Use the RESTORE CHP command to configure a specified channel online to the host image on which the target I/O operations is running. See "REMOVE CHP" on page 241 for information on the reciprocal command.

### Syntax

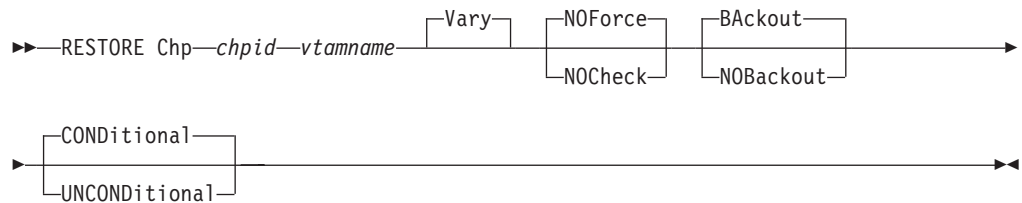

### Parameters

**chpid**

Specify the CHPID to be restored as a hexadecimal number in the range X'00—FF'.

**vtamname**

Specify the VTAM application name of the target I/O operations. The target program is the I/O operations that instructs its host image to configure the specified CHPID online.

## RESTORE CHP

The target system can be any I/O operations host to which a VTAM session is established.

You can specify THIS-SYS in uppercase characters if the issuing I/O operations is the target program and if any of the following conditions holds:

- The issuing I/O operations does not have a valid VTAM name.
- The issuing I/O operations' VTAM name is not available.
- VTAM is not available.

**Note:** Use the Display Host \* command to see if the issuing I/O operations calls itself THIS-SYS.)

## Options

### VARY

VARY is the default and NOVary is *not* an alternative.

The target I/O operations configures the CHPID online before issuing the vary path-online requests for all the relevant paths that are defined to the specified CHPID in the host I/O Control Data Set (IOCDs).

### NOForce | NOCheck

NOForce is the default. Although you can enter NOCheck, it has no additional effect in this command.

### BAckout | NOBackout

BAckout is the default. Although you can enter NOBackout, I/O operations's processing is not different for this command.

For both BAckout and NOBackout, I/O operations:

- Attempts to configure the channel back offline if the program is running under MVS and timed out with the status of the channel uncertain.
- Does not attempt to vary any paths back offline if one or more relevant vary path-online requests fail.

### CONDitional

This is the default option for both the REMOVE and RESTORE CHP commands. It indicates that no special configure offline or configure online action should be performed.

### UNCONDitional

For the REMOVE CHP command, this option puts the specified chpids immediately into pending offline status, even if the chpids are currently active, allocated, or reserved.

For the RESTORE CHP command, this option brings the specified chpids online, even if there are no paths to the chpids, or if the chpids are pending offline and boxed.

## Usage

- The CHPID type must be known to the target I/O operations.
- If the RESTORE CHP command causes one or more devices to be made available to the host image on which the target I/O operations is running, I/O operations automatically attempts to add these devices to its internal configuration map.
- I/O operations does not attempt to configure the channel online if the target I/O operations is reset off or purged from intersystem communication.

- The target I/O operations cannot bring a channel online if that channel is not available to the host image on which the target program is running.
- If the target I/O operations is running in an MVS environment and if the program timed out with the state of the CHPID unknown, I/O operations attempts to configure the channel back offline.
- If you are considering specifying a CVC channel for this command, note that I/O operations does *not* automatically attempt to configure a CVC CHPID offline when it processes any of the the following commands for a path defined with that CHPID: Chain, Restore Switch, or Unblock. You can, however, use the RESTORE CHP command to configure the CVC CHPID online.
- The command is not supported if the target I/O operations is running on a host system that is operating as a guest in a VM environment.

---

## RESTORE SWITCH

### Purpose

Use the RESTORE SWITCH command to restore logical path status through a switch. I/O operations automatically issues any vary path requests that are needed to synchronize path status with the current physical settings stored at the switch.

If the switch is not allocated that will now be done.

See “REMOVE SWITCH” on page 243 for the reciprocal command and “Restore (Enable) a Switch” on page 342 for a discussion.

### Syntax

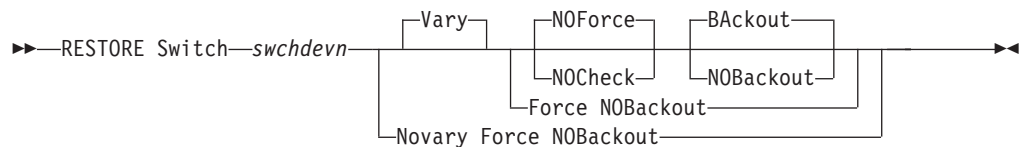

### Parameters

#### swchdevn

Specifies the switch to be restored. For a discussion, see “Switch Identifiers” on page 333.

### Options

#### Connectivity options

For a discussion on Vary | NOVary, NOForce | NOCheck | Force, and BACkout | NOBACkout see “Making Connectivity Changes” on page 340.

### Usage

- The Restore Switch command restores paths attached to the switch according to the current switch settings-to units.
- If you replace a switch, which was disabled with the Remove Switch command, with another switch, any previous chaining data is voided. Chaining data in the new switch is used, instead. If the replacement switch is physically linked to

## RESTORE SWITCH

another switch, you must define the chained path. See “Chain and Unchain a Switchable Path” on page 334 for more information.

### Examples

```
RESTORE S 100  
IHVC000I RESTORE    command successful
```

---

## SYNC SWITCH

### Purpose

Use the SYNC SWITCH to build and, optionally, to issue vary path requests that would be required to synchronize path status with the current settings maintained at the specified switch.

### Syntax

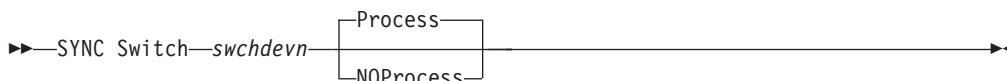

### Parameters

#### swchdevn

Specifies the switch. For a discussion, see “Switch Identifiers” on page 333.

### Options

#### Process

(default) instructs the issuing I/O operations to issue the appropriate vary path requests.

#### NOProcess

instructs I/O operations to build the list, but not to process it.

### Usage

- Use the command described in “DISPLAY VARY” on page 236 to display the vary path requests that would be required if you choose the noprocess option or the failed vary path requests if you chose the process option.
- Consider using the command if you have entered one or more connectivity commands with the Force option, knowing that pathing status will no longer be synchronous with the switch settings.
- Consider using the SYNC SWITCH command if connectivity changes have been made to the switch at the switch console.
- SYNC SWITCH differs from RESET SWITCH in that the latter command synchronizes the issuing I/O operations’ internal configuration map with the physical settings of the switch, but does not synchronize path status.

## UNBLOCK

### Purpose

Use the UNBLOCK command to permit data transfer through a port that had been blocked. See "BLOCK" on page 214 for the reciprocal command.

### Syntax

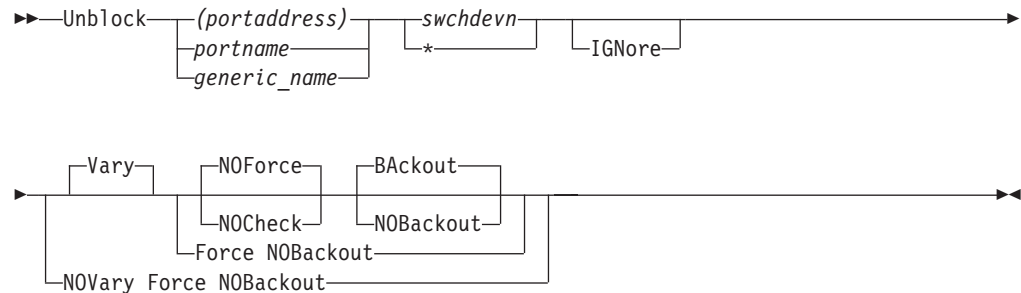

### Parameters

**(portaddress) | portname | generic\_name**

Specifies the port to be unblocked by its port address (enclosed in parentheses), by its individual port name, or by a generic port name. For a discussion, see "Port Switching Commands" on page 345.

**swchdevn | \***

Specifies one switch or all switches (\* not enclosed in parentheses) allocated to the issuing I/O operations. For a discussion, see "Switch Identifiers" on page 333.

### Options

**IGNore**

You must specify this option when an Inter-Switch-Link port (E\_Port) is involved. Otherwise the command is rejected with return code 8 and reason code X'49'. The reason is I/O operations can no longer guarantee "safe-switching" when an E\_Port is involved.

"Safe-switching" sets the paths and devices online or offline when the path from a chpid to a device either becomes valid or is no longer valid because of a port manipulation.

**Connectivity options**

For a discussion on Vary | NOVary, NOForce | NOCheck | Force, and Backout | NOBackout see "Making Connectivity Changes" on page 340.

### Usage

If a CVC or parallel CHPID is involved, see "A "Partially-ESCON" Path" on page 338 for more information.

# UNBLOCK

## Examples

```
UNBLOCK (D6) 100
IHVC000I UNBLOCK    command successful
```

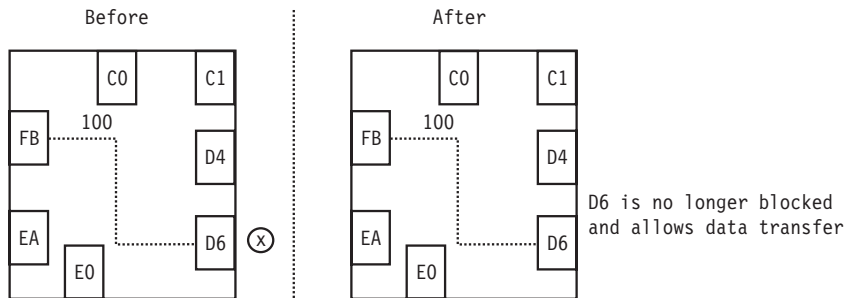

Figure 131. UNBLOCK Command - Sample 1

```
U CU.F00 *
IHVC000I UNBLOCK    command successful
```

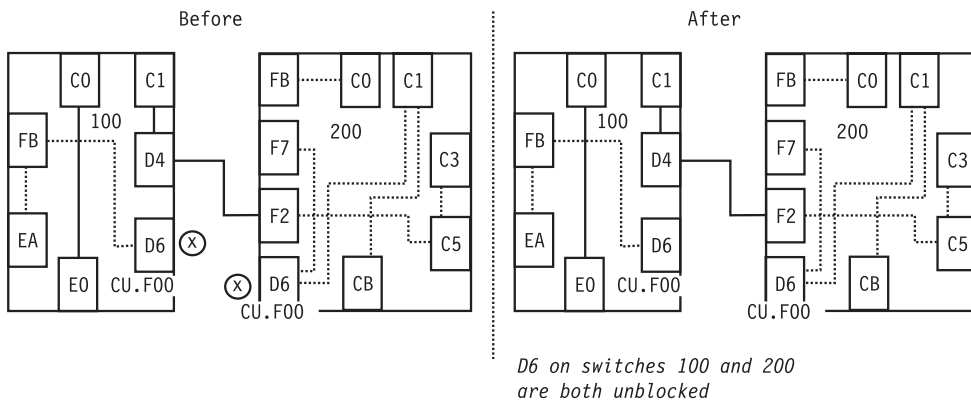

Figure 132. UNBLOCK Command - Sample 2

# UNCHAIN

## Purpose

Use the UNCHAIN command to cancel the definition of a chain in a chained path. See "Chain and Unchain a Switchable Path" on page 334 for more information. See "CHAIN" on page 216 for the reciprocal command.

**Note:** The UNCHAIN command is not applicable to FICON switches.

## Syntax

```
UNCHAIN (portaddress_e) destination_swchdevn (portaddress_m)
```

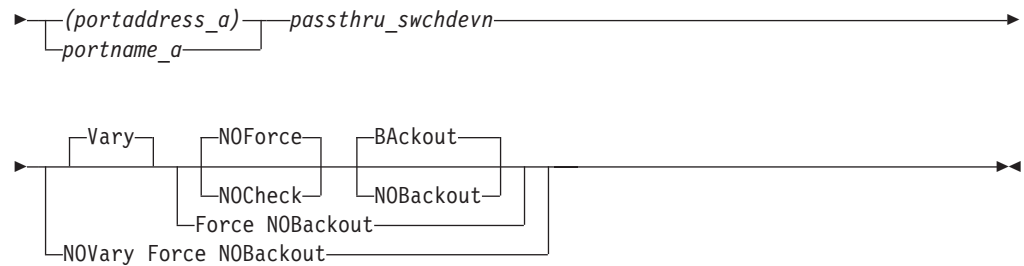

## Parameters

### (portaddress\_e) | portname\_e

Specifies the end port by its port address (enclosed in parentheses) or by its port name. For a discussion, see “Port Switching Commands” on page 345.

### destination\_swchdevn

Specifies the device number of the destination switch in the chained path. For a discussion, see “Switch Identifiers” on page 333.

### (portaddress\_m) | portname\_m

Specifies middle port by its port address (enclosed in parentheses) or by its port name. For a discussion, see “Port Switching Commands” on page 345.

### (portaddress\_a) | portname\_a

Specifies the port in the chained path to which the CHPID or control unit is physically attached by its port address (enclosed in parentheses) or by its port name. For a discussion, see “Port Switching Commands” on page 345.

### passthru\_swchdevn

Specifies the device number of the pass-thru switch in the chained path. For a discussion, see “Switch Identifiers” on page 333.

## Options

### Connectivity options

For a discussion on Vary | NOVary, NOForce | NOCheck | Force, and BAckout | NOBackout see “Making Connectivity Changes” on page 340.

## Usage

- Use the Force option to remove a chained path that is supporting the last path to the switch.
- Make sure that you cancel the definition of a chain before you recable either of the chained switches of the chained ports that are affected.
- The definition of a chain is voided if either of the chained switches is replaced.

## Examples

```
UNCHAIN (F2) 200 (D4) (C1) 100
IHVC000I UNCHAIN      command successful
```

# UNLOCK

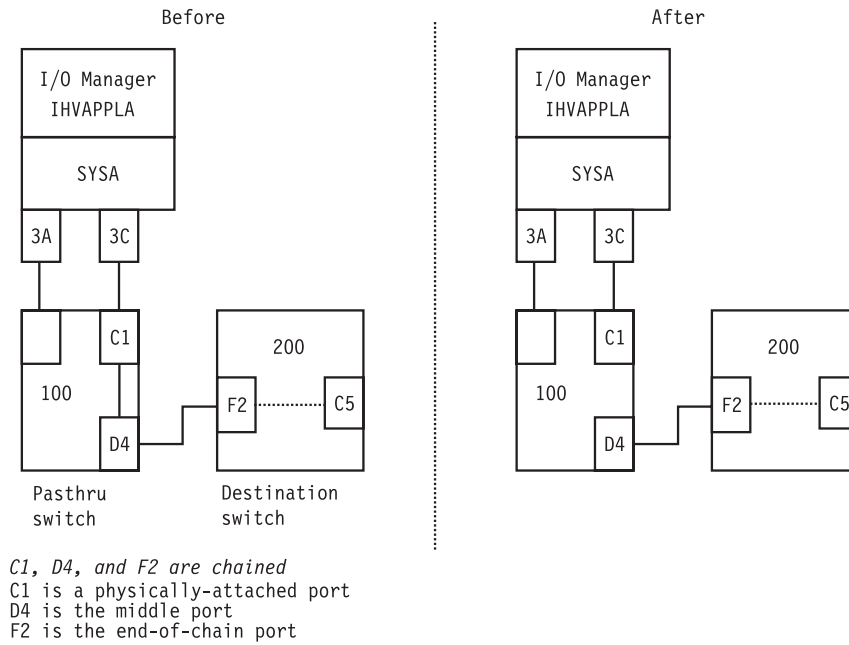

Figure 133. UNCHAIN Command - Sample

## UNLOCK

### Purpose

Use the UNLOCK command to release I/O operations processing from your user ID, so that another user ID can use an I/O operations within the same set. (A set of I/O operations consists of the participants in the issuing I/O operations' vary-path processing and those I/O operations that can communicate with any of the participants.)

See "GETLOCK" on page 238 for the reciprocal command.

### Syntax

►► UNLOCK ◀◀

### Examples

```
UNLOCK  
IHVC000I UNLOCK      command successful
```

## WRITE

### Purpose

Use the WRITE command to assign, or to write, a port name to an addressable port on one or on all the switches allocated to the issuing I/O operations.

### Syntax

```
►► Write portname (portaddress) swchdevn *
```

### Parameters

#### portname

Specifies the port name you want to be assigned. To avoid assigning a port name that contains an unprintable character, specify the name in uppercase letters and use only the following special characters: digits, period, underscore. Do not exceed 24 characters. See “Using Port Names as a Tool in Switching Commands” on page 343 for more information.

#### (portaddress)

Specifies the addressable port to which the port name is being assigned.

#### swchdevn | \*

Specifies one switch or all switches (\* not enclosed in parentheses) allocated to the issuing I/O operations. For a discussion, see “Switch Identifiers” on page 333.

### Usage

- When assigning a name to a port, consider whether you want that port to be targeted by a generic name.
- The Write command refreshes the data that could be displayed with the Display Results command. Therefore, it is advisable to assign port names when I/O operations is started.
- If you are using the sample ISPF dialog, you can assign a switch device name to a switch. The name will be displayed in the dialog’s display of that switch configuration in matrix format.
  - Either name the name of the switch in the SWCH Name field of the matrix , as described under “A Sample Way to Modify a Switch Matrix” on page 348.
  - Or, use the Write command to write a port name to the switch’s control unit port (CUP). If you do not know the CUP address, you can find out with the DISPLAY DEV command. (For example, enter D D 0500 \* for switch 500. In the displayed output, the CUP is to the right of CONTROL UNIT DATA.

### Examples

```
W HA.CHP_88.CVC (C0) 100
IHVC0001 WRITE      command successful
```

# WRITE

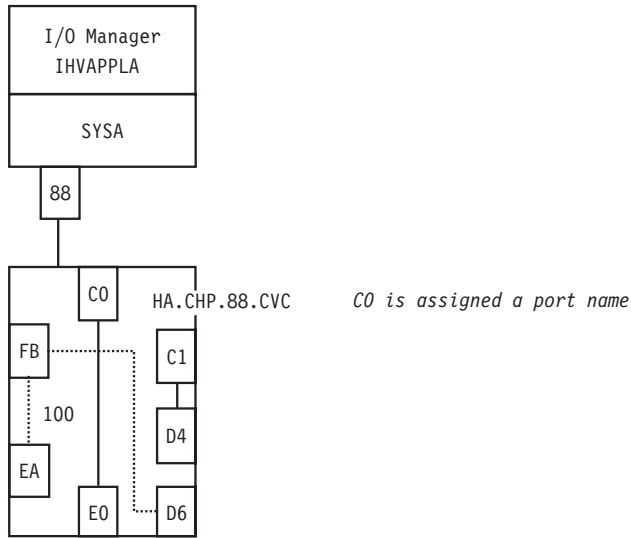

Figure 134. WRITE Command - Sample 1

```
WRITE CU.F00 (D6) *
IHVC000I WRITE        command successful
```

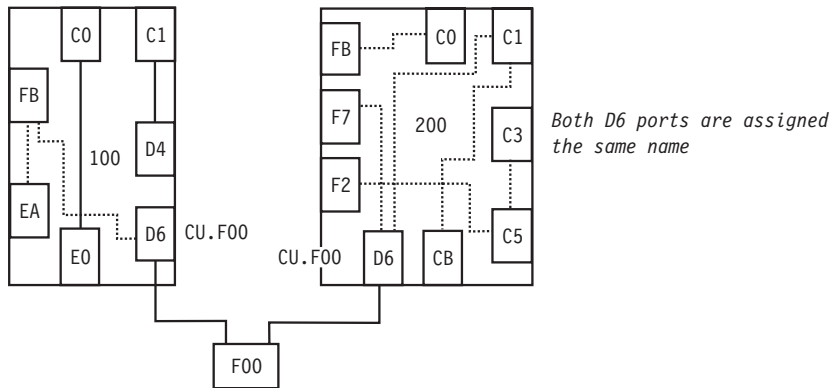

Figure 135. WRITE Command - Sample 2

---

## Part 4. SA OS/390 Processor Operations Commands

<b>Using Processor Operations Commands</b> . . . . .	261	ISQCHK . . . . .	298
General Information . . . . .	261	ISQCMON . . . . .	299
Host-Based Commands . . . . .	261	ISQEXEC . . . . .	300
Common Commands . . . . .	261	ISQHELP . . . . .	301
		ISQOVRD . . . . .	303
<b>Common Commands</b> . . . . .	263	ISQSEND . . . . .	304
ACTIVATE . . . . .	263	ISQSTART . . . . .	305
CBU . . . . .	276	ISQSTOP . . . . .	307
DEACTIVATE . . . . .	277	ISQVARS . . . . .	308
EXTINT . . . . .	281	ISQXCLS . . . . .	318
LOAD . . . . .	283	ISQXDRL . . . . .	319
RESTART . . . . .	288	ISQXDST . . . . .	320
START . . . . .	289	ISQXIII . . . . .	323
STOP . . . . .	290	ISQXLOC . . . . .	325
SYSRESET . . . . .	291	ISQXMOP . . . . .	326
		ISQXOPT . . . . .	328
		ISQXUNL . . . . .	330
<b>Host-based Commands</b> . . . . .	297		
ISQCCMD . . . . .	297		

This part describes SA OS/390 processor operations commands in detail—their purpose, their format, and specifics of how to use them.

For general information about the SA OS/390 commands, refer to *System Automation for OS/390 User's Guide*.



---

# Using Processor Operations Commands

---

## General Information

Processor operations commands consist of the following basic types:

- Host-based commands
- Common commands

You generally issue processor operations commands at a NetView console from the focal-point system. Alternatively, you can use an NMC, customized for SA OS/390 exploitation to issue context-sensitive processor operations commands for target hardware or target system objects by supplementing the prepared command templates.

Commands which start with ISQ are issued as shown in the syntax diagrams, starting with the command name.

Except for the common commands, processor operations commands whose names do not start with ISQ are preceded by the ISQSEND command.

---

## Host-Based Commands

The ISQSEND command sends the command to a target operating system for processing, using the processor operations connection to the processor hardware. Processor operations connections from the focal-point to the target hardware use either the support element of the addressed target hardware or can be customized to use an HMC, connected to the target hardware LAN for communication. Because the connection to a target hardware and the operating systems running on that hardware is available at target system initialization time or system shutdown time, the ISQSEND command can be used to respond to IPL prompt messages or to answer outstanding replies at system shutdown time.

The ISQSEND command addresses the operating system running on a processor hardware. The command ISQCCMD addresses the processor hardware or a processor hardware image (logical partition). The processor hardware which can be monitored and controlled by processor operations provide the OCF (operations command facility). This system management interface is called by ISQCCMD to perform hardware commands, for example, ACTIVATE or SYSRESET.

Other host-based processor operations commands control the start and the stop of the processor operations component of SA OS/390, invoke the status display system, control the monitoring of messages from the target systems, and allow the display and modification of processor operations configuration information.

---

## Common Commands

Common commands are preceded by the ISQCCMD command (described in detail on page 297). Use common commands in APIs whenever possible because they provide a single product image across various hardware and software implementations. Regardless of the processor type or the operating system running at your target system, the common command is the same. This can potentially minimize the need for future modifications to your automation routines should you modify or upgrade your processor hardware or operating system type.



---

## Common Commands

This chapter describes the common commands provided by SA OS/390 processor operations. Common commands provide a single-product image across various hardware and software implementations, potentially minimizing future modifications.

---

### ACTIVATE

#### Purpose

The ACTIVATE command causes the target system to perform a complete initialization. This initialization extends from a power-on reset to performing the initial program load process.

#### Syntax

```
▶ ISQCCMD target_system_ProcOps_name
           ┌ group_name
           └ subgroup_name
```

```
▶ ACTIVATE FORCE ( NO
                  └ YES
                  ┌ ,S (wait_units)
                  └ ,M (wait_units)
                  └ ,H (wait_units)
```

```
▶ CNAME (profile_name)
   ┌ XATIME (yyyymmddhhmi) [UTC]
   └ XBTIME (yyyymmddhhmi) [UTC]
   └ Options
```

#### Options:

```
└ INTERVAL (dddhmi)
  └ COUNT (—count_of_intervals—)
```

#### Requirements

The requirements for the ACTIVATE command to complete successfully are:

- Processor operations must be active.

## ACTIVATE

- The addressed target system must have a status of UNKNOWN, CLOSED, or INITIALIZED for the default setting of FORCE(NO) to work. See “Examples” on page 322 for a list of status settings.

### Parameters

For a definition of *target\_system\_ProcOps\_name*, *group\_name*, and *subgroup\_name*, refer to “ISQCCMD” on page 297.

#### FORCE

Requests conditional processing of commands that are disruptive to the operating system control program and application work that is in progress. Use of this operand is based on the operating state of the target processor.

#### NO

Specifies that processing of the command is to continue *only* if the target CPU control program is not in the operating state. Specify FORCE(NO) in a situation where you would *not* want to disrupt the control program work-in-progress.

#### YES

Specifies that processing of the command is to continue *even* if the target CPU control program is in the operating state. Specify FORCE(YES) in a situation where disruption of the control program work-in-progress is not important, such as in recovery situations.

**S** Specifies that the time-out value is measured in seconds.

**M** Specifies that the time-out value is measured in minutes.

**H** Specifies that the time-out value is measured in hours.

#### *wait-units*

Specifies an optional time-out value in 1-to-5 decimal digits, ranging from 0 to 65535. This value provides the OCF with an interval for delaying the acceptance of, or rejection of, the command. The presence of this value in the operand causes the OCF to signal a quiesce event to the operating system control program, for those operating systems that support this action.

A time-out value is only allowed on timed command requests.

When a time-out value is specified with FORCE(NO), the associated command is held pending until the control program enters a quiesced state, or until the time-out value expires. If the time-out value expires, the command is treated as a FORCE(NO) with no time-out value.

When a time-out value is specified with FORCE(YES), the associated command is held pending until the control program enters a quiesced state, or until the time-out value expires. If the time-out value expires, the command is treated as a FORCE(YES) with no time-out value.

FORCE(NO) requires that the associated command *fail* when useful work is taking place. For ACTIVATE these *fail* states are *operating* and *wait*. when FORCE(NO) is specified or when FORCE defaults to NO. The command fails whenever the processor is in those states.

#### CNAME

Specifies the name of a profile to be sent to the processor’s support element. If this keyword is not used, SA OS/390 selects a profile name from among those specified in the configuration dialogs, and uses it in the ACTIVATE operations management command sent to the support element. The selection is based on

## ACTIVATE

the current status (ESA or LPAR) of the target hardware and the actual status of the target system. If this keyword is not used and no appropriate profile name was specified in the configuration dialogs, SA OS/390 processor operations omits the CNAME operand from the ACTIVATE command sent to the support element.

### *profile\_name*

Indicates the name of the profile. It is recommended to let processor operations select the profile name automatically rather than overriding processor operations' selection with the *profile\_name* parameter.

## XATIME

Specifies a time *<at or after>* which the associated command may begin processing. The time specified is determined by the OCF clock of the receiving support element.

### *yyyy*

Specifies a year, in 4 decimal digits. It must be greater than 1988.

*mo* Specifies a month of the year, in 2 decimal digits, from 01 to 12.

*dd* Specifies a day of the month, in 2 decimal digits, from 01 to 31.

*hh* Specifies an hour of the day, in 2 decimal digits, from 00 to 23.

*mi* Specifies a number of minutes, in 2 decimal digits, from 00 to 59.

## UTC

If present, indicates that the time is coordinated universal time.

The system must be power-on reset in LPAR mode before sending a scheduled request for a secondary OCF. If it is not, the request is rejected.

The default, if XATIME is not explicitly stated, is for the command to be processed immediately.

When XATIME is not accompanied by an XBTIME, there is no end time by which command processing must be started.

## XBTIME

Specifies a time *<at or before>* which the associated command must begin processing. A combination of XATIME and XBTIME specifies a "timing-window" within which processing is to be attempted.

### *yyyy*

Specifies a year, in 4 decimal digits. It must be greater than 1988.

*mo* Specifies a month of the year, in 2 decimal digits, from 01 to 12.

*dd* Specifies a day of the month, in 2 decimal digits, from 01 to 31.

*hh* Specifies an hour of the day, in 2 decimal digits, from 00 to 23.

*mi* Specifies a number of minutes, in 2 decimal digits, from 00 to 59.

## UTC

Indicates that the time is coordinated universal time.

The system must be power-on reset in LPAR mode before sending a scheduled request for a secondary OCF. If it is not, the request is rejected.

When XBTIME is not accompanied by an XATIME, the command may be processed immediately.

## ACTIVATE

### INTERVAL

Indicates that the associated command is to be processed repeatedly. It specifies the time span between processing repetitions. The specified value is added to XATIME, XBTIME, or both (if both are present in the command), to determine the next processing time.

*ddd*

Specifies a number of days, in 3 decimal digits, from 000 to 048.

*hh* Specifies a number of hours, in 2 decimal digits, from 00 to 23.

*mi* Specifies a number of minutes, in 2 decimal digits, from 00 to 59.

#### Notes:

1. The default, if INTERVAL is not explicitly stated, is one execution of the command.
2. INTERVAL is only valid if XATIME or XBTIME, or both, are also present in the command.
3. Within a given timing-window, there may be only one repetition of a command.

### COUNT

Specifies the number of times, based on specified timing controls, that processing of an operations command should be attempted. Timing controls are provided through the combined use of the XATIME, XBTIME, INTERVAL, and COUNT operands.

#### count-of-intervals

Is a decimal value, from 1 to 65535. This value indicates the maximum number of times that processing is to be attempted and is decremented after each processing attempt. When the count has been decremented to zero, the request is removed from the timed list.

The default value, if COUNT is not explicitly stated, is for the timing-window interval to be repeated forever, or until canceled.

Use of the COUNT operand requires that INTERVAL, and a combination of either XATIME or XBTIME.

## Usage

**Caution:** The ACTIVATE command can be very disruptive when you specify FORCE(YES), so use this command carefully. The SA OS/390 processor operations status facility knows only about status changes performed from within SA OS/390. If you load and start a target system's operating system outside of SA OS/390 (such as from the SA OS/390 processor operations passthru facility or from the console at the remote target system) rather than by using the SA OS/390 commands, SA OS/390 does not know that the status of the target system has changed.

The effect of the ACTIVATE FORCE keyword applies only to target systems defined to SA OS/390. Because SA OS/390 does not know the target system was activated from outside of SA OS/390, it considers the target system status to be UNKNOWN. The functions performed by the ACTIVATE common command will disrupt the operating system even if you specify the FORCE(NO) option because the SA OS/390 status facility does not indicate that the target system is already initialized and running.

When you do not specify FORCE(YES):

- The ACTIVATE command checks whether the same logical partition name is in use by another target system. If so, the ACTIVATE command is rejected; if not, processing continues.
- ACTIVATE also checks target hardware that is not logically partitioned to see if the target hardware is in use by another target system. If so, the ACTIVATE command is rejected; if not processing continues.

For target hardware configured for a NetView connection (NVC) you can delay execution of the ACTIVATE command by using the scheduled request operands (XATIME, XBTIME, INTERVAL, and COUNT). Use these operands carefully. Once an ACTIVATE command with scheduled request operands has been sent to the target system (or target systems), there is no further interaction with the focal-point system until the ACTIVATE commands eventually complete execution, which could be hours or even days later. Moreover, when the command includes the INTERVAL operand and possibly also the COUNT operand, the ACTIVATE commands can run multiple times, further extending the duration and impact of the effects of the original ACTIVATE command issued on the focal-point system.

ACTIVATE processing can also produce the result that more target systems are affected than the one explicitly specified in the command or those included in a target group or subgroup specified in the command. The additional target systems are CPC images on a processor in LPAR mode. These additional target systems are activated when a Reset or Image profile specifies additional profile names in the AUTOACT operand. To avoid unintended activations, operators should be kept aware of the linkages between profiles.

Using either scheduled requests or auto-activated logical partitions causes SA OS/390 to receive "unsolicited" responses from one or more target systems. SA OS/390 uses these responses to update its status information and to attempt to initialize the corresponding target systems.

When you specify FORCE(YES):

- The ACTIVATE command overrides the requirements that a target system have a status of UNKNOWN, CLOSED, or INITIALIZED.
- Processing of the ACTIVATE command is performed even if the target system has a status condition of IPL COMPLETE, IPL FAILED, LOAD FAILED, or one of the WAITING FOR...MESSAGE conditions.

The ACTIVATE command performs only the processing that is required. For example, it performs a power-on reset only when required, and it does not initialize a target system that is already initialized correctly.

## Restrictions and Limitations

The ACTIVATE command does not perform resource requirement checks.

The default form of the ACTIVATE command is rejected if the addressed target system has a status other than UNKNOWN, CLOSED, or INITIALIZED.

SNMP-connected target hardware cannot process the following parameters:

INTERVAL  
XATIME  
XBTIME

## ACTIVATE

The S, H, M timeout values of the FORCE parameter

### Return Codes

The ISQCCMD command (described on page 297) generates the return codes for common command processing.

#### The ACTIVATE Command

The effects of an ACTIVATE common command issued to an OCF-based processor depend on several factors, the most important of which are the profile(s) used during command processing and the current and intended state of the processor.

Table 4 on page 270 shows the relationships among these factors and the processing results in various circumstances. The meaning of the columns in the table is as follows:

Column Heading	Meaning
Intended Result of ACTIVATE	The mode of the target hardware (ESA or LPAR) and the processing you want to take place as a result of the ACTIVATE command. You indicate your intention by means of the profile that you specify on the command or that processor operations or the support element selects for use.
Current Target Hardware State and Mode	The actual state and mode of the processor at the time you issue the command. The current state can be: <ul style="list-style-type: none"><li>• POWERED OFF</li><li>• POWER-ON RESET REQUIRED</li><li>• POWER-ON RESET COMPLETE</li></ul> If the state is POWER-ON RESET COMPLETE, a target system may or may not have been activated.
Profile Name in ACTIVATE Command Issued by User	The name of a profile you specified in the CNAME operand of the ACTIVATE command, or None.
Profile Name(s) Available from Configuration Dialogs	The names of one or more profiles that may have been defined to processor operations in the configuration dialogs. If no CNAME operand is specified on the ACTIVATE command, processor operations looks for a profile name of the appropriate type in the internal table built from the configuration dialog input. Reset, Image, and Load profile names may be specified on the Target System Description panels for OCF-based processors. See the description of panels ISQDPT5B and ISQDPT5C in <i>System Automation for OS/390 Customizing and Programming</i> .
Operands in ACTIVATE Command processor operations Sends to Support Element	Processor operations sometimes modifies the ACTIVATE command you issue, and it sends the modified command to the processor's support element. These two columns show how processor operations indicates which profile and operations command facility (OCF) are to be used for processing the command.
Profile Name	The profile name, if any, that processor operations puts in the CNAME operand.
OCF	The indication processor operations gives of the operations command facility (OCF) to be used. The primary OCF is indicated by omitting the OCFNAME operand, and a secondary OCF is indicated by giving the OCF's name in the OCFNAME operand.

## ACTIVATE

<b>Column Heading</b>	<b>Meaning</b>
Support Element (SE)	These two columns describe the effects of the ACTIVATE command from the perspective of the processor's support element.
Recommended Profile	The profile(s) IBM recommends using for the circumstances described in the columns to the left.
Processing	The processing the support element performs as a result of the ACTIVATE command sent by processor operations.

# ACTIVATE

Table 4. Profiles and the ACTIVATE Command for OCF-Based Processors

Intended Result of ACTIVATE	Current Target Hardware State and Mode	Profile Name in Activate Command Issued by User	Profile Name Available from Customization Dialogs	Operands in ACTIVATE Command Processor Operations Sends to Support Element		Support Element (SE)	
				Profile Name	OCF	Recommended Profile	Processing
ESA mode Power-on reset CPC  Optionally IPL target system (CPC)	POWER-ON RESET REQUIRED or POWERED OFF	CNAME operand	Not used	Profile specified in user command	Primary	Reset profile with AUTOACT operand pointing to Load profile	SE powers on CPC (if required) and performs power-on reset processing as specified in the specified Reset profile.  SE IPLs the CPC as specified in a Load profile: <ul style="list-style-type: none"> <li>If AUTOACT operand in Reset profile points to a Load profile, SE uses that Load profile.</li> <li>If Reset profile has no AUTOACT operand, SE uses the default Load profile.</li> </ul> If the name specified in the command is not a Reset profile, SE rejects the command.
		None	Reset profile	Reset profile specified in customization dialogs	Primary		
		None	None	None	Primary		
ESA mode IPL target system (CPC)	POWER-ON RESET COMPLETE Target system activated or not activated ESA mode	CNAME operand	Not used	Profile specified in user command	Primary	Load profile	IPLs the CPC as specified in the Load profile.  IPLs the CPC as specified in the Load profile pointed to in the default Reset profile. <ul style="list-style-type: none"> <li>If the default Reset profile has no AUTOACT operand, SE uses the default Load profile.</li> </ul>
		None	Load profile	Load profile specified in customization dialogs	Primary		
		None	None	None	Primary		

Table 4. Profiles and the ACTIVATE Command for OCF-Based Processors (continued)

Intended Result of ACTIVATE	Current Target Hardware State and Mode	Profile Name in Activate Command Issued by User	Profile Name Available from Customization Dialogs	Operands in ACTIVATE Command Processor Operations Sends to Support Element		Support Element (SE)	
				Profile Name	OCF	Recommended Profile	Processing
ESA mode Power-on reset CPC Optionally IPL target system (CPC)	POWER-ON RESET COMPLETE Target system activated or not activated LPAR mode	CNAME operand None	Not used Reset profile	Profile specified in user command Reset profile specified in customization dialogs None	Primary Primary Primary	Reset profile with AUTOACT operand pointing to Load profile	<p>Initializes the target hardware into ESA mode as specified in the specified Reset profile.</p> <p>SE IPLs the CPC as specified in a Load profile:</p> <ul style="list-style-type: none"> <li>• If AUTOACT operand in Reset profile points to a Load profile, SE uses that Load profile.</li> <li>• If Reset profile has no AUTOACT operand, SE uses the default Load profile.</li> </ul> <p>If the name specified in the command is not a Reset profile, SE rejects the command.</p> <p>Initializes the target hardware into ESA mode as specified in the SE's default Reset profile.</p> <p>If the default Reset profile points to a Load profile (as it does when initially set up by IBM), SE IPLs the CPC using that profile.</p> <ul style="list-style-type: none"> <li>• If the default Reset profile has no AUTOACT operand, SE uses the default Load profile.</li> </ul>

# ACTIVATE

Table 4. Profiles and the ACTIVATE Command for OCF-Based Processors (continued)

Intended Result of ACTIVATE	Current Target Hardware State and Mode	Profile Name in Activate Command Issued by User	Profile Name Available from Customization Dialogs	Operands in ACTIVATE Command Processor Operations Sends to Support Element		Support Element (SE)	
				Profile Name	OCF	Recommended Profile	Processing
LPAR mode Power-on reset CPC Optionally activate one or more target systems (partitions) Optionally IPL one or more target systems (partitions)	POWER-ON RESET REQUIRED or POWERED OFF	CNAME operand	Not used	Profile specified in user command	Primary	Reset profile with AUTOACT operand pointing to Image profile(s)	SE powers on CPC (if required) and performs power-on reset processing as specified in the specified Reset profile. • If specified profile is not a Reset profile, SE rejects the command.  SE activates partitions specified in Image profile(s) pointed to by the AUTOACT operand in Reset profile. • If no Image profiles are specified, no partitions are activated. • If an Image profile contains Load information, the image is IPLed. – A load is not attempted if the Image is in coupling facility mode.
		None	Reset profile	Reset profile specified in customization dialogs	Primary		
		None	None	None	Primary		As initially set up by IBM, the default Reset profile specifies ESA mode. Therefore, for the SE to be able to use default profiles to power-on reset the CPC in LPAR mode and to activate partitions as described above, the default Reset profile must have been changed to specify LPAR mode. In that case, processing is as described above.

Table 4. Profiles and the ACTIVATE Command for OCF-Based Processors (continued)

Intended Result of ACTIVATE	Current Target Hardware State and Mode	Profile Name in Activate Command Issued by User	Profile Name Available from Customization Dialogs	Operands in ACTIVATE Command Processor Operations Sends to Support Element		Support Element (SE)	
				Profile Name	OCF	Recommended Profile	Processing
LPAR mode Activate target system (partition) Optionally IPL target system (partition)	POWER-ON RESET COMPLETE Target system not activated LPAR mode	CNAME operand	Not used	Profile specified in user command	Secondary	Image profile	SE activates and possibly IPLs partition as specified in an Image or Load profile <ul style="list-style-type: none"> <li>If the specified profile is an Image profile:                             <ul style="list-style-type: none"> <li>Activate partition using specified Image profile.</li> <li>If the Image profile contains Load information, the image is IPLed.                                     <ul style="list-style-type: none"> <li>A load is not attempted if the Image is in coupling facility mode.</li> </ul> </li> </ul> </li> <li>If the specified profile is a Load profile:                             <ul style="list-style-type: none"> <li>Activate partition using Image profile with the same name as the partition</li> <li>IPL partition using specified Load profile.</li> <li>If the Image profile specifies coupling facility mode, the SE does not activate the partition.</li> </ul> </li> </ul> If the name specified in the command is neither an Image nor Load profile, SE rejects the command.  SE attempts to use the default Image profile and usually fails. Succeeds only when the partition is named "DEFAULT".
		None	Image or Load profile	Image profile specified in customization dialogs, if available. Otherwise, Load profile	Secondary		
			None	None	Secondary		

# ACTIVATE

Table 4. Profiles and the ACTIVATE Command for OCF-Based Processors (continued)

Intended Result of ACTIVATE	Current Target Hardware State and Mode	Profile Name in Activate Command Issued by User	Profile Name Available from Customization Dialogs	Operands in ACTIVATE Command Processor Operations Sends to Support Element		Support Element (SE)	
				Profile Name	OCF	Recommended Profile	Processing
LPAR mode Activate target system (partition) Optionally IPL target system (partition)	POWER-ON RESET COMPLETE Target system activated LPAR mode	CNAME operand	Not used	Profile specified in user command	Secondary	Image profile	SE activates and possibly IPLs partition as specified in an Image or Load profile <ul style="list-style-type: none"> <li>If the specified profile is an Image profile:               <ul style="list-style-type: none"> <li>Deactivate partition.</li> <li>Activate partition using specified Image profile.</li> <li>If the Image profile contains Load information, the image is IPLed.                   <ul style="list-style-type: none"> <li>A load is not attempted if the Image is in coupling facility mode.</li> </ul> </li> <li>If the specified profile is a Load profile:                   <ul style="list-style-type: none"> <li>IPL partition using specified Load profile.</li> <li>If the partition is in coupling facility mode, the Activate fails.</li> </ul> </li> </ul> </li> </ul>
		None	Load or Image profile	Load profile specified in customization dialogs, if available. Otherwise, Image profile	Secondary		
			None	None	Secondary		

Table 4. Profiles and the ACTIVATE Command for OCF-Based Processors (continued)

Intended Result of ACTIVATE	Current Target Hardware State and Mode	Profile Name in Activate Command Issued by User	Profile Name Available from Customization Dialogs	Operands in ACTIVATE Command Processor Operations Sends to Support Element		Support Element (SE)	
				Profile Name	OCF	Recommended Profile	Processing
LPAR mode Power-on reset CPC Optionally activate one or more target systems (partitions) Optionally IPL one or more target systems (partitions)	POWER-ON RESET COMPLETE Target system activated or not activated ESA mode	CNAME operand	Not used	Profile specified in user command	Primary	Reset profile with AUTOACT operand pointing to Image profile(s)	Initializes the target hardware into LPAR mode as specified in the specified Reset profile. Activates partition(s) specified in the Image profile(s) if the Reset profile contains an AUTOACT operand pointing to Image profile(s). <ul style="list-style-type: none"> <li>If no Image profiles are specified, no partitions are activated.</li> <li>If an Image profile contains Load information, the image is IPLed.</li> </ul> If the name specified in the command is a Load profile, the SE remains in ESA mode and it IPLs the CPC.  If the name specified in the command is neither a Reset nor Load profile, SE rejects the command.  As initially set up by IBM, the default Reset profile specifies ESA mode. Therefore, for the SE to be able to use default profiles to power-on reset the CPC in LPAR mode and to activate partitions as described above, the default Reset profile must have been changed to specify LPAR mode. In that case, processing is as described above.
		None	Reset profile	Reset profile specified in customization dialogs	Primary	None	
			None	None	Primary		

## Purpose

The CBU command causes the target hardware processor to perform the specified capacity backup (CBU) function if available.

With the CBU command you can temporarily increase the control program (CP) capacity of your central processor complex (CPC). In case of an outage, which may have reduced your overall processor capacity, additional workload can be processed on that CPC.

## Syntax

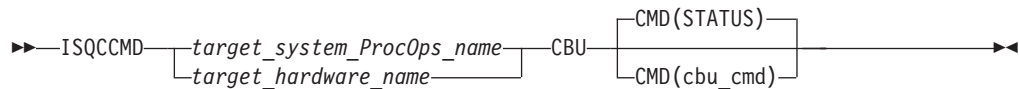

## Requirements

The requirements for the CBU command to complete successfully are:

- Processor operations must be active.
- The addressed target system must be initialized, or, if the target hardware is addressed, at least one target system on that hardware must be initialized.

## Parameters

For a definition of *target\_system\_ProcOps\_name*, and *target\_hardware\_name*, refer to “ISQCCMD” on page 297.

### CBU

Indicates the CBU command function to be executed.

#### cmd\_cmd

Is the name of the command to be executed

#### STATUS

Returns the current status of the CBU facility of the addressed CPC. The possible status values returned are:

##### AVAILABLE

CBU is installed on the CPC.

##### ACTIVATED

CBU is started through ACTIVATE command.

##### NOT\_ACTIVATED

CBU is installed but not activated.

##### NOT\_ENABLED

CBU is installed but not enabled.

##### NOT\_INSTALLED

CBU is not installed on the CPC.

##### UNAVAILABLE

CBU is installed but no longer available.

The ISQCCMD response message ISQ4647I contains the status report.

**ACTIVATE**

Activates the previously installed and enabled CBU.

**TESTACT**

Activates the previously installed and enabled CBU in test mode.

**UNDO**

Deactivates a previously activated CBU to the regular configuration. Note, that this function is not available on all CPCs supporting CBU. If the UNDO command fails, the regular CPC configuration must be restored by performing a POWERON-RESET of the CPC.

**Defaults**

The default of the CBU command is CMD(STATUS).

**Usage**

Issue the CBU command to temporarily increase the control program (CP) capacity of your central processor complex (CPC). The increased capacity may require to update your CPC's activation profiles, so that the additional processor resources can be used in your processor configuration.

For more information refer to *Capacity Backup User's Guide*.

**Restrictions and Limitations**

The CBU common command is only supported for SNMP connections. If a CBU request is issued for a NetView connection, it cannot be processed.

**Return Codes**

The ISQCCMD command (described on page 297) generates the return codes for common command processing.

**DEACTIVATE**

**Purpose**

The DEACTIVATE command causes the target system to end normal operation. It also closes the system console and operator console ports.

**Syntax**

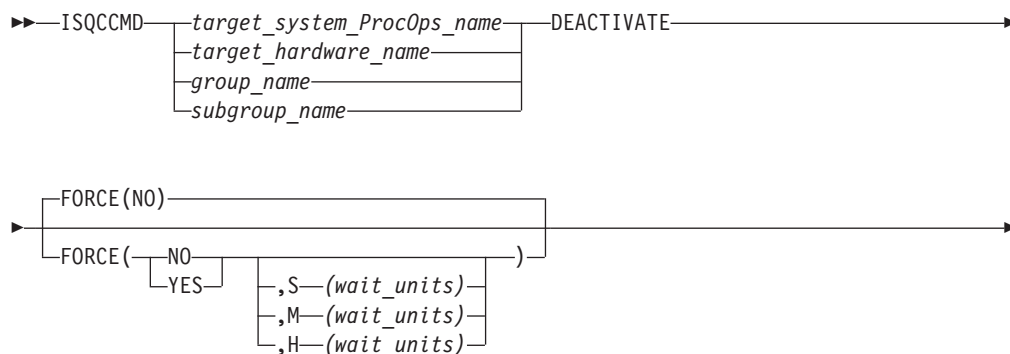

## DEACTIVATE

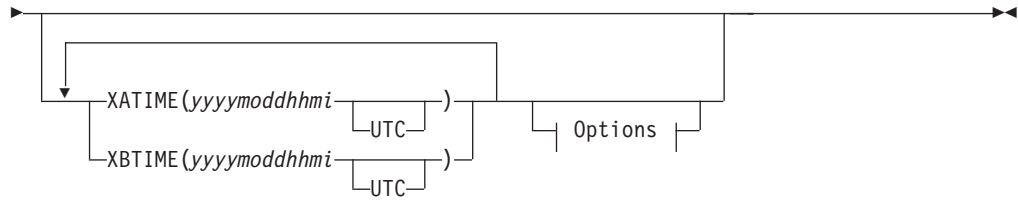

### Options:

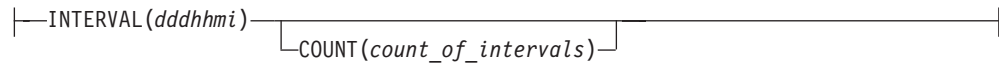

## Requirements

Processor operations must be active for this command to complete successfully.

The addressed target system must be initialized.

## Parameters

For a definition of *target\_system\_ProcOps\_name*, *group\_name*, and *subgroup\_name*, refer to "ISQCCMD" on page 297.

### FORCE

Requests conditional processing of commands that are disruptive to the operating system control program and application work that is in progress. Use of this operand is based on the operating state of the target processor.

### NO

Specifies that processing of the command is to continue *only* if the target CPU control program is not in the operating state. Specify FORCE(NO) in a situation where you would *not* want to upset the control program work-in-progress.

### YES

Specifies that processing of the command is to continue *even* if the target CPU control program is in the operating state. Specify FORCE(YES) in a situation where disruption of the control program work-in-progress is not important, such as in recovery situations.

**S** Specifies that the time-out value is measured in seconds.

**M** Specifies that the time-out value is measured in minutes.

**H** Specifies that the time-out value is measured in hours.

### *wait-units*

Specifies an optional time-out value in 1-to-5 decimal digits, ranging from 0 to 65535. This value provides the OCF with an interval for delaying the acceptance of, or rejection of, the command. The presence of this value in the operand causes the OCF to signal a quiesce event to the operating system control program, for those operating systems that support this action.

A time-out value is only allowed on timed command requests.

When a time-out value is specified with FORCE(NO), the associated command is held pending until the control program enters a quiesced

## DEACTIVATE

state, or until the time-out value expires. If the time-out value expires, the command is treated as a FORCE(NO) with no time-out value.

When a time-out value is specified with FORCE(YES), the associated command is held pending until the control program enters a quiesced state, or until the time-out value expires. If the time-out value expires, the command is treated as a FORCE(YES) with no time-out value.

The default, if FORCE is not explicitly stated, is FORCE(NO).

FORCE(NO) requires that the associated command *fail* when useful work is taking place. The DEACTIVATE command's formal fail criteria when FORCE(NO) is specified or when FORCE defaults to NO is *operating*.

### XATIME

Specifies a time *<at or after>* which the associated command may begin processing. The time specified is determined by the OCF clock of the receiving support element.

*yyyy*

Specifies a year, in 4 decimal digits. It must be greater than 1988.

*mo* Specifies a month of the year, in 2 decimal digits, from 01 to 12.

*dd* Specifies a day of the month, in 2 decimal digits, from 01 to 31.

*hh* Specifies an hour of the day, in 2 decimal digits, from 00 to 23.

*mi* Specifies a number of minutes, in 2 decimal digits, from 00 to 59.

### UTC

If present, indicates that the time is coordinated universal time.

The system must be power-on reset in LPAR mode before sending a scheduled request for a secondary OCF. If it is not, the request is rejected.

The default, if XATIME is not explicitly stated, is for the command to be processed immediately.

When XATIME is not accompanied by an XBTIME, there is no end time by which command processing must be started.

### XBTIME

Specifies a time *<at or before>* which the associated command must begin processing. A combination of XATIME and XBTIME specifies a "timing-window" within which processing is to be attempted.

*yyyy*

Specifies a year, in 4 decimal digits. It must be greater than 1988.

*mo* Specifies a month of the year, in 2 decimal digits, from 01 to 12.

*dd* Specifies a day of the month, in 2 decimal digits, from 01 to 31.

*hh* Specifies an hour of the day, in 2 decimal digits, from 00 to 23.

*mi* Specifies a number of minutes, in 2 decimal digits, from 00 to 59.

### UTC

Indicates that the time is coordinated universal time.

The system must be power-on reset in LPAR mode before sending a scheduled request for a secondary OCF. If it is not, the request is rejected.

## DEACTIVATE

When XBTIME is not accompanied by an XATIME, the command may be processed immediately.

### INTERVAL

Indicates that the associated command is to be processed repeatedly. It specifies the time span between processing repetitions. The specified value is added to XATIME, XBTIME, or both (if both are present in the command), to determine the next processing time.

*ddd*

Specifies a number of days, in 3 decimal digits, from 000 to 048.

*hh* Specifies a number of hours, in 2 decimal digits, from 00 to 23.

*mi* Specifies a number of minutes, in 2 decimal digits, from 00 to 59.

#### Notes:

1. The default, if INTERVAL is not explicitly stated, is one execution of the command.
2. INTERVAL is only valid if XATIME or XBTIME, or both, are also present in the command.
3. Within a given timing-window, there may be only one repetition of a command.

### COUNT

Specifies the number of times, based on specified timing controls, that processing of an operations command should be attempted. Timing controls are provided through the combined use of the XATIME, XBTIME, INTERVAL, and COUNT operands.

#### count-of-intervals

Is a decimal value, from 1 to 65535. This value indicates the maximum number of times that processing is to be attempted and is decremented after each processing attempt. When the count has been decremented to zero, the request is removed from the timed list.

The default value, if COUNT is not explicitly stated, is for the timing-window interval to be repeated forever, or until canceled.

Use of the COUNT operand requires that INTERVAL, and a combination of either XATIME or XBTIME.

## Defaults

The DEACTIVATE command defaults to FORCE(NO).

## Usage

Use this common command to close a target system. Closing a target system does the following:

- Ends any active sessions with the target system
- Disables the target system
- Performs any required end-of-day activities
- Quiesces the target system

If this command is directed to a target hardware name rather than to a target system ProcOps name, the entire processor complex is brought to a power-off state.

If you do not specify FORCE(YES), the DEACTIVATE command checks to make sure it will not be disruptive by performing the following processing:

- If the target system runs in a logical partition and the same logical partition name is initialized to another target system in the same target hardware, the DEACTIVATE command is rejected and processing of the command halts.
- On a non-partitioned target system, if the target hardware has another target system initialized to it, the DEACTIVATE command is rejected and processing of the command halts.

## Restrictions and Limitations

- When closing a target system, the DEACTIVATE common command issues an MVS QUIESCE (or equivalent) command and hardware system reset at the system console port if appropriate. This processor command may be processed in the NNT-driven part of shutdown procedures, if necessary.
- The DEACTIVATE common command also performs a system reset of the target system, and disables and releases the focal-point ports.
- To reinitialize a target system that was shut down with the DEACTIVATE common command, you must issue the ACTIVATE common command (described on page 263).
- The DEACTIVATE common command does not close processor operations PC ports. Use the ISQXCLS command (described on page 318) to perform these actions.
- On processor S/390 Multiprise 3000 from the 390-CMOS hardware family, the DEACTIVATE common command will issue a power-off if no more images are found operational. The integrated support element is also switched off. This is different from other processors of the 390-CMOS family, where the power-off stage of the DEACTIVATE command only affects the CPC but not the SE. A powered-off Multiprise 3000 cannot be restarted using SA OS/390 processor operations. The system must be started manually before the OCF can be used to perform an ACTIVATE command remotely.
- SNMP-connected target hardware cannot process the following parameters:
  - INTERVAL
  - XATIME
  - XBTIME
  - The S, H, M timeout values of the FORCE parameter

## Return Codes

The ISQCCMD command (described on page 297) generates the return codes for common command processing.

## EXTINT

### Purpose

The EXTINT command causes the target system to perform the external interrupt function on a central processor that exists on a target hardware processor.

### Syntax

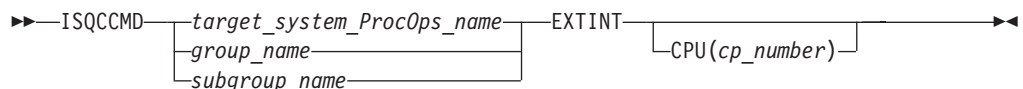

## EXTINT

### Requirements

Processor operations must be active for this command to complete successfully.

The addressed target system must be initialized for this command to complete successfully.

### Parameters

For a definition of *target\_system\_ProcOps\_name*, *group\_name*, and *subgroup\_name*, refer to "ISQCCMD" on page 297.

#### CPU

Indicates a central processor is to be interrupted.

(*cp\_number*)

Is the address of the central processor to be interrupted.

Valid values are 0, 1, 2, 3, 4, 5, 6, 7, 8 or 9. The *cp\_number* variable is dependent on the type, model and configuration of the processor targeted. The following processors are supported: zSeries and 390-CMOS.

No space is allowed between the keyword CPU and the left parenthesis.

### Defaults

This command defaults to the current central processor on the addressed target hardware if a central processor is not specified.

To find out this value for a target system hardware connected with a NetView connection, issue the following command string:

```
ISQSEND target SC PROFILE OP(READ) TYPE(Load) CNAME(profile_name)
```

This command cannot be used for target hardware with an SNMP connection. For SNMP-connected target hardware, the EXTINT command is supported by the zSeries processor family.

### Usage

Issue the EXTINT command to generate an interrupt request to the processor which will be processed at the end of the current unit of work (unless other interrupt requests are pending), causing the program status word (PSW) to be swapped with a new PSW, and initiating processing from an address in the new PSW.

### Restrictions and Limitations

- This command is not supported for coupling facility target systems.
- The values for the CPU keyword cannot exceed what is physically installed in the processor.

### Return Codes

The ISQCCMD command (described on page 297) generates the return codes for common command processing.

# LOAD

## Purpose

The LOAD command performs the initial program load process for a target system processor. This command is not supported for coupling facility target systems.

## Syntax

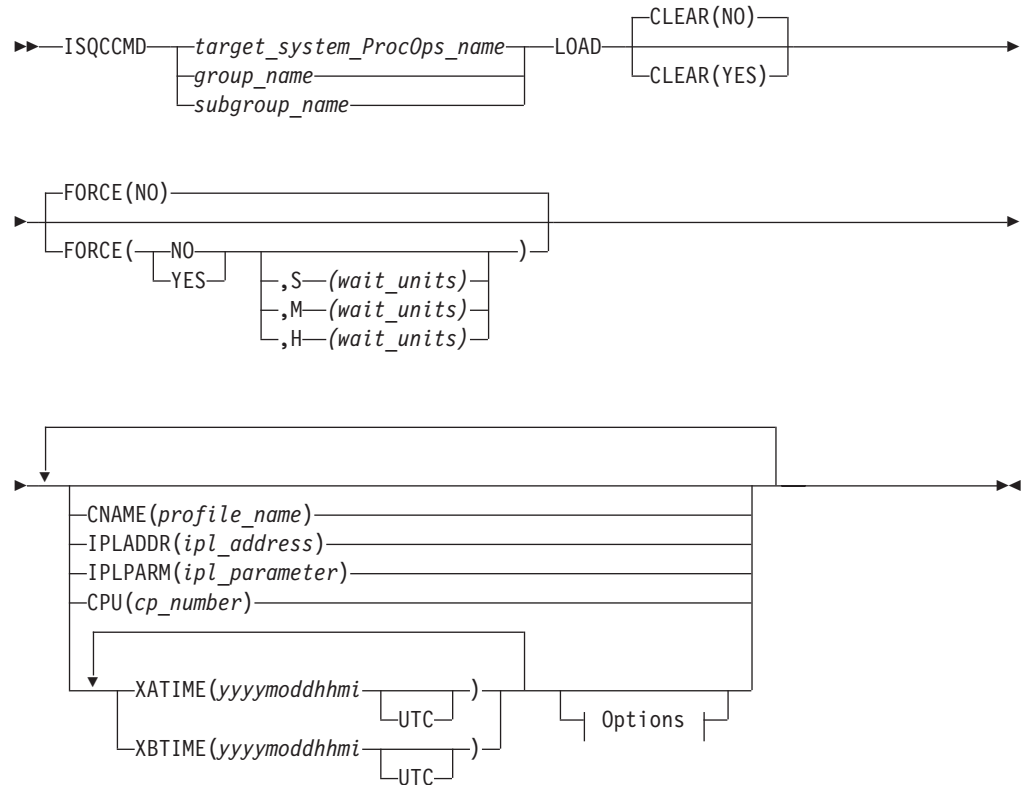

### Options:

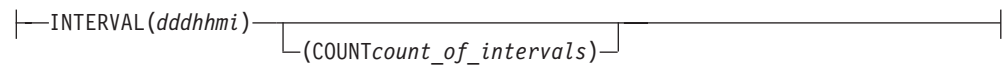

## Requirements

The requirements for this command to complete successfully are:

- Processor operations must be active.
- The addressed target system must be initialized.
- The addressed target system must have a status of at least INITIALIZED.
- The addressed target system cannot have a status of UNKNOWN, CLOSED, or IPL COMPLETE for the default setting of FORCE(NO) to work.

## Parameters

For a definition of *target\_system\_ProcOps\_name*, *group\_name*, and *subgroup\_name*, refer to "ISQCCMD" on page 297.

## LOAD

### CLEAR(NO)

Indicates the function of clearing storage is not to be performed; the LOAD common command issues a normal LOAD command. No space is allowed between the keyword CLEAR and the left parenthesis. This is the default.

### CLEAR(YES)

Indicates the function of clearing storage is to be performed; the LOAD common command issues a LOAD CLEAR command. No space is allowed between the keyword CLEAR and the left parenthesis.

### FORCE

Requests conditional processing of commands that are disruptive to the operating system control program and application work that is in progress. Use of this operand is based on the operating state of the target processor.

### NO

Specifies that processing of the command is to continue *only* if the target CPU control program is not in the operating state. Specify FORCE(NO) in a situation where you would *not* want to upset the control program work-in-progress.

### YES

Specifies that processing of the command is to continue *even* if the target CPU control program is in the operating state. Specify FORCE(YES) in a situation where disruption of the control program work-in-progress is not important, such as in recovery situations.

**S** Specifies that the time-out value is measured in seconds.

**M** Specifies that the time-out value is measured in minutes.

**H** Specifies that the time-out value is measured in hours.

### *wait-units*

Specifies an optional time-out value in 1-to-5 decimal digits, ranging from 0 to 65535. This value provides the OCF with an interval for delaying the acceptance of, or rejection of, the command. The presence of this value in the operand causes the OCF to signal a quiesce event to the operating system control program, for those operating systems that support this action.

A time-out value is only allowed on timed command requests.

When a time-out value is specified with FORCE(NO), the associated command is held pending until the control program enters a quiesced state, or until the time-out value expires. If the time-out value expires, the command is treated as a FORCE(NO) with no time-out value.

When a time-out value is specified with FORCE(YES), the associated command is held pending until the control program enters a quiesced state, or until the time-out value expires. If the time-out value expires, the command is treated as a FORCE(YES) with no time-out value.

The default, if FORCE is not explicitly stated, is FORCE(NO).

FORCE(NO) requires that the associated command *fail* when useful work is taking place. For this command the formal fail criteria when FORCE(NO) is specified or when FORCE defaults to NO is the *operating* state.

### IPLADDR

Indicates that the variable following it in parenthesis is the IPL address parameter.

*(ipl\_address)*

Specifies the IPL address as four hexadecimal digits. No space is allowed between the keyword IPLADDR and the left parenthesis.

### IPLPARM

Indicates that the variable following it in parenthesis is an IPL parameter.

*(ipl\_parameter)*

Specifies an IPL parameter to be issued with the Load command. This parameter can be 1 through 8 characters long. Lowercase letters are translated to uppercase letters. No space is allowed between the keyword IPLPARM and the left parenthesis.

### CPU

Indicates that the variable following it in parentheses is the central processor address parameter.

*(cp\_number)*

Specifies the central processor address.

Valid values are 0, 1, 2, 3, 4, 5, 6, 7, 8 or 9. The *cp\_number* variable is dependent on the type, model and configuration of the processor targeted. The following processors are supported: zSeries and 390-CMOS.

Specifying this parameter also changes the value in the internal variable for the addressed target system to the number of the specified central processor address. No space is allowed between the keyword CPU and the left parenthesis.

### CNAME

Specifies the name of a Load profile to be sent to the processor's support element. If this keyword is not used, the LOAD operations management command SA OS/390 sends to the support element has a CNAME operand with the Load profile name specified in the configuration dialogs. If this keyword is not used and no Load profile name was specified in the configuration dialogs, SA OS/390 omits the CNAME operand from the LOAD command sent to the support element. In this latter case, the support element uses its default Load profile.

*profile\_name*

Indicates the name of the profile. IBM recommends that you let SA OS/390 select the profile name automatically rather than overriding SA OS/390's selection with the *profile\_name* parameter.

### XATIME

Specifies a time *<at or after>* which the associated command may begin processing. The time specified is determined by the OCF clock of the receiving support element.

*yyyy*

Specifies a year, in 4 decimal digits. It must be greater than 1988.

*mo* Specifies a month of the year, in 2 decimal digits, from 01 to 12.

*dd* Specifies a day of the month, in 2 decimal digits, from 01 to 31.

*hh* Specifies an hour of the day, in 2 decimal digits, from 00 to 23.

*mi* Specifies a number of minutes, in 2 decimal digits, from 00 to 59.

### UTC

If present, indicates that the time is coordinated universal time.

## LOAD

The system must be power-on reset in LPAR mode before sending a scheduled request for a secondary OCF. If it is not, the request is rejected.

The default, if XATIME is not explicitly stated, is for the command to be processed immediately.

When XATIME is not accompanied by an XBTIME, there is no end time by which command processing must be started.

### **XBTIME**

Specifies a time *<at or before>* which the associated command must begin processing. A combination of XATIME and XBTIME specifies a "timing-window" within which processing is to be attempted.

*yyyy*

Specifies a year, in 4 decimal digits. It must be greater than 1988.

*mo* Specifies a month of the year, in 2 decimal digits, from 01 to 12.

*dd* Specifies a day of the month, in 2 decimal digits, from 01 to 31.

*hh* Specifies an hour of the day, in 2 decimal digits, from 00 to 23.

*mi* Specifies a number of minutes, in 2 decimal digits, from 00 to 59.

### **UTC**

Indicates that the time is coordinated universal time.

The system must be power-on reset in LPAR mode before sending a scheduled request for a secondary OCF. If it is not, the request is rejected.

When XBTIME is not accompanied by an XATIME, the command may be processed immediately.

### **INTERVAL**

Indicates that the associated command is to be processed repeatedly. It specifies the time span between processing repetitions. The specified value is added to XATIME, XBTIME, or both (if both are present in the command), to determine the next processing time.

*ddd*

Specifies a number of days, in 3 decimal digits, from 000 to 048.

*hh* Specifies a number of hours, in 2 decimal digits, from 00 to 23.

*mi* Specifies a number of minutes, in 2 decimal digits, from 00 to 59.

#### **Notes:**

1. The default, if INTERVAL is not explicitly stated, is one execution of the command.
2. INTERVAL is only valid if XATIME or XBTIME, or both, are also specified in the command.
3. Within a given time-frame, there may be only one repetition of a command.

### **COUNT**

Specifies the number of times, based on specified timing controls, that processing of an operations command should be attempted. Timing controls are provided through the combined use of the XATIME, XBTIME, INTERVAL, and COUNT operands.

#### **count-of-intervals**

Is a decimal value, from 1 to 65535. This value indicates the maximum

number of times that processing is to be attempted and is decremented after each processing attempt. When the count has been decremented to zero, the request is removed from the timed list.

The default value, if COUNT is not explicitly stated, is for the timing-window interval to be repeated forever, or until cancelled.

Use of the COUNT operand requires that INTERVAL, and a combination of either XATIME or XBTIME.

## Defaults

The LOAD command defaults to CLEAR(NO) and to FORCE(NO).

The *ipl\_address*, *ipl\_parameter*, and *cp\_number* parameters default to the values defined in the configuration dialogs, unless they have been changed with the ISQVARS or ISQXOPT command, described on page 328, in which case the values defined by the ISQVARS or ISQXOPT command are used.

For OCF-based processors, the *ipl\_address*, *ipl\_parameter*, and *cp\_number* parameters default to the values specified in the Load profile. You can find out these values by issuing the following command string:

```
ISQSEND target SC PROFILE OP(READ) TYPE(LOAD) CNAME(profile_name)
```

## Usage

This common command assumes that the processor operations environment has been established and that the system console function has been assigned. For a target system operating on an LPAR-mode processor, it also assumes that the logical partition is active and that any required channels are online to the partition. If these assumptions are not correct, other initialization commands should be run first. These functions of the LOAD common command are all performed by the ACTIVATE common command.

If you do not specify FORCE(YES), the LOAD common command checks to make sure it will not be disruptive by performing the following processing:

- If the target system runs in a logical partition and the same logical partition name is initialized to another target system in the same target hardware, the LOAD command is rejected and processing of the command halts.
- On a non-partitioned target system, if the target hardware has another target system initialized to it, the LOAD command is rejected and processing of the command halts.

## Restrictions and Limitations

SNMP-connected target hardware cannot process the following parameters:

```
INTERVAL
XATIME
XBTIME
```

The S, H, M timeout values of the FORCE parameter

This command is not supported for coupling facility target systems.

The values for *cp\_number* cannot exceed what is physically installed in the processor.

## LOAD

If you do not specify FORCE(YES), the LOAD common command is rejected if the addressed target system has a status of UNKNOWN, CLOSED, or IPL COMPLETE. To perform the load process for a target system that is in a status condition of UNKNOWN or CLOSED, issue the ACTIVATE common command (described on page 263). If the addressed target system has a status of IPL COMPLETE, you can specify FORCE(YES) to perform the IPL process without deactivating the target system first.

## Return Codes

The ISQCCMD command (described on page 297) generates the return codes for common command processing.

---

## RESTART

### Purpose

The RESTART command causes the target system processor to perform the restart function. This function consists of loading the restart program status word (PSW).

### Syntax

```
▶▶—ISQCCMD—target_system_ProcOps_name—RESTART—CPU(cp_number)—▶▶  
          └─group_name—  
          └─subgroup_name—
```

### Requirements

Processor operations must be active for this command to complete successfully.

The addressed target system must be initialized for this command to complete successfully.

### Parameters

For a definition of *target\_system\_ProcOps\_name*, *group\_name*, and *subgroup\_name*, refer to “ISQCCMD” on page 297.

#### CPU

Indicates that a central processor is to be restarted.

*cp\_number*

Specifies the central processor address.

Valid values are 0, 1, 2, 3, 4, 5, 6, 7, 8 or 9. The *cp\_number* variable is dependent on the type, model and configuration of the processor targeted. The following processors are supported: zSeries and 390-CMOS.

No space is allowed between the keyword CPU and the left parenthesis.

### Defaults

This command defaults to the current central processor on the addressed target hardware if a central processor is not specified. Depending on the processor, the current central processor may be the default specified on the processor’s OPRCTL panel.

To find out this value issue the following command string:

```
ISQSEND target SC PROFILE OP(READ) TYPE(LOAD) CNAME(profile_name)
```

## Usage

The RESTART command is normally used to return the processor to an active processing state from a QUIESCE or SHUTDOWN condition.

The RESTART command can also be used to recover from various system problems.

## Restrictions and Limitations

- The values for the CPU keyword cannot exceed what is physically installed in the processor.
- For SNMP-connected target hardware the CPU keyword is not supported.

## Return Codes

The ISQCCMD command (described on page 297) generates the return codes for common command processing.

# START

## Purpose

The START command causes the target system processor to perform the start function. This function consists of returning the operating system to the operating state from the stopped state initiated by the STOP command.

## Syntax

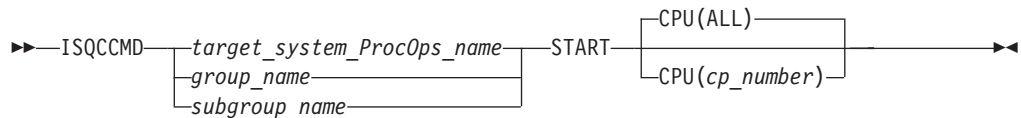

## Requirements

Processor operations must be active for this command to complete successfully.

The addressed target system must be initialized for this command to complete successfully.

## Parameters

For a definition of *target\_system\_ProcOps\_name*, *group\_name*, and *subgroup\_name*, refer to "ISQCCMD" on page 297.

### CPU(ALL)

Specifies all central processors are to be started. This is the default. No space is allowed between the keyword CPU and the left parenthesis.

### CPU(*cp\_number*)

Specifies the number of the central processor to be started.

Valid values are 0, 1, 2, 3, 4, 5, 6, 7, 8 or 9. The *cp\_number* variable is dependent on the type, model and configuration of the processor targeted. The following processors are supported: zSeries and 390-CMOS.

## START

No space is allowed between the keyword CPU and the left parenthesis.

### Defaults

The START command defaults to CPU(ALL).

### Usage

The START command is equivalent to pressing the START key at a target system.

Use the START command to cancel the effects of the STOP command and allow the operating system to run again.

### Restrictions and Limitations

- The values for the CPU number cannot exceed what is physically installed in the processor.
- This command is not supported for coupling facility target systems.
- For SNMP-connected target hardware the CPU keyword is not supported.

### Return Codes

The ISQCCMD command (described on page 297) generates the return codes for common command processing.

---

## STOP

### Purpose

The STOP command causes the target system processor to perform the stop function. This function consists of placing the processor in the stopped state at the end of the current unit of operation.

### Syntax

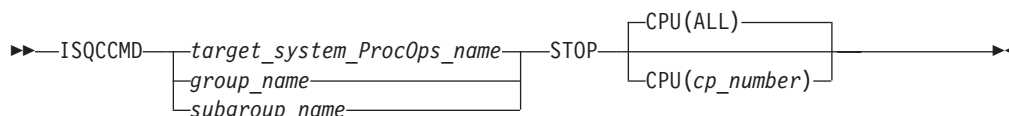

### Requirements

Processor operations must be active for this command to complete successfully.

The addressed target system must be initialized for this command to complete successfully.

### Parameters

For a definition of *target\_system\_ProcOps\_name*, *group\_name*, and *subgroup\_name*, refer to "ISQCCMD" on page 297.

#### CPU(ALL)

Specifies that all central processors are to be stopped. This is the default. No space is allowed between the keyword CPU and the left parenthesis.

#### CPU(*cp\_number*)

Specifies the number of the central processor to be stopped.

## STOP

Valid values are 0, 1, 2, 3, 4, 5, 6, 7, 8 or 9. The *cp\_number* variable is dependent on the type, model and configuration of the processor targeted. The following processors are supported: zSeries and 390-CMOS.

No space is allowed between the keyword CPU and the left parenthesis.

## Defaults

The STOP command defaults to CPU(ALL).

## Usage

Use the STOP command to temporarily halt normal operations. You can use this command to interrupt processing to perform various hardware maintenance functions (such as cleaning the heads of a tape drive) and then continue processing from the point at which it stopped.

## Restrictions and Limitations

- The values for the CPU keyword cannot exceed what is physically installed in the processor.
- This command is not supported for coupling facility target systems.
- For SNMP-connected target hardware the CPU keyword is not supported.

## Return Codes

The ISQCCMD command (described on page 297) generates the return codes for common command processing.

---

## SYSRESET

### Purpose

The SYSRESET command causes the target system processor to perform the system reset function. This function consists of resetting and initializing the processor.

### Syntax

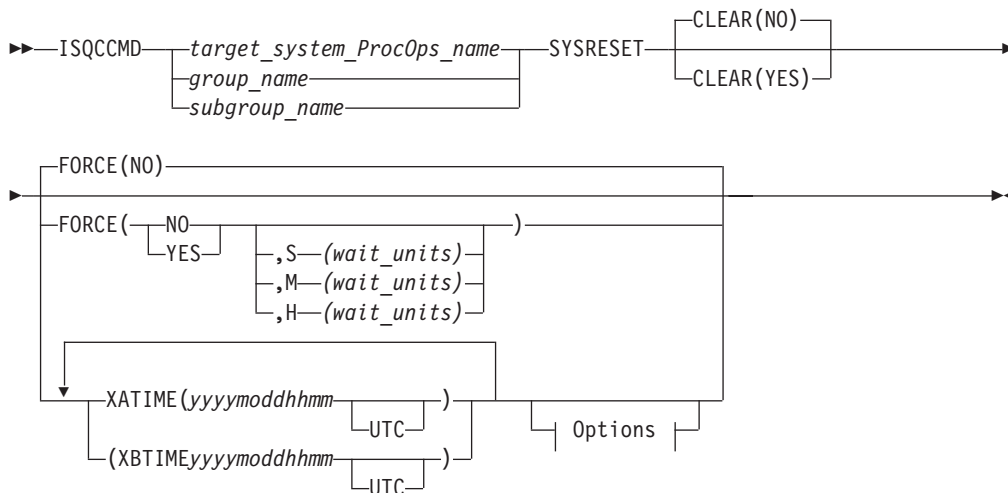

## SYSRESET

### Options:

|—INTERVAL(*dddhhmi*)—|  
|—COUNT(*count\_of\_intervals*)—|

## Requirements

Processor operations must be active for this command to complete successfully.

The addressed target system must be initialized for this command to complete successfully.

## Parameters

For a definition of *target\_system\_ProcOps\_name*, *group\_name*, and *subgroup\_name*, refer to “ISQCCMD” on page 297.

### CLEAR(NO)

Indicates that the option of clearing storage is not being specified. This is the default value. No space is allowed between the keyword CLEAR and the left parenthesis.

### CLEAR(YES)

Indicates that the option of clearing storage is being specified. No space is allowed between the keyword CLEAR and the left parenthesis.

### FORCE

Requests conditional processing of commands that are disruptive to the operating system control program and application work that is in progress. Use of this operand is based on the operating state of the target processor.

### NO

Specifies that processing of the command is to continue *only* if the target CPU control program is not in the operating state. Specify FORCE(NO) in a situation where you would *not* want to upset the control program work-in-progress.

### YES

Specifies that processing of the command is to continue *even* if the target CPU control program is in the operating state. Specify FORCE(YES) in a situation where disruption of the control program work-in-progress is not important, such as in recovery situations.

**S** Specifies that the time-out value is measured in seconds.

**M** Specifies that the time-out value is measured in minutes.

**H** specifies that the time-out value is measured in hours.

### *wait-units*

Specifies an optional time-out value in 1-to-5 decimal digits, ranging from 0 to 65535. This value provides the OCF with an interval for delaying the acceptance of, or rejection of, the command. The presence of this value in the operand causes the OCF to signal a quiesce event to the operating system control program, for those operating systems that support this action.

A time-out value is only allowed on timed command requests.

When a time-out value is specified with FORCE(NO), the associated command is held pending until the control program enters a quiesced

state, or until the time-out value expires. If the time-out value expires, the command is treated as a FORCE(NO) with no time-out value.

When a time-out value is specified with FORCE(YES), the associated command is held pending until the control program enters a quiesced state, or until the time-out value expires. If the time-out value expires, the command is treated as a FORCE(YES) with no time-out value.

The default, if FORCE is not explicitly stated, is FORCE(NO).

FORCE(NO) requires that the associated command *fail* when useful work is taking place. For SYSRESET the formal fail criteria is *operating* when FORCE(NO) is specified or when FORCE defaults to NO. The command will fail whenever the processor is in this state.

### XATIME

Specifies a time *<at or after>* which the associated command may begin processing. The time specified is determined by the OCF clock of the receiving support element.

*yyyy*

Specifies a year, in 4 decimal digits. It must be greater than 1988.

*mo* Specifies a month of the year, in 2 decimal digits, from 01 to 12.

*dd* Specifies a day of the month, in 2 decimal digits, from 01 to 31.

*hh* Specifies an hour of the day, in 2 decimal digits, from 00 to 23.

*mi* Specifies a number of minutes, in 2 decimal digits, from 00 to 59.

### UTC

If present, indicates that the time is coordinated universal time.

The system must be power-on reset in LPAR mode before sending a scheduled request for a secondary OCF. If it is not, the request is rejected.

The default, if XATIME is not explicitly stated, is for the command to be processed immediately.

When XATIME is not accompanied by an XBTIME, there is no end time by which command processing must be started.

### XBTIME

Specifies a time *<at or before>* which the associated command must begin processing. A combination of XATIME and XBTIME specifies a "timing-window" within which processing is to be attempted.

*yyyy*

Specifies a year, in 4 decimal digits. It must be greater than 1988.

*mo* Specifies a month of the year, in 2 decimal digits, from 01 to 12.

*dd* Specifies a day of the month, in 2 decimal digits, from 01 to 31.

*hh* Specifies an hour of the day, in 2 decimal digits, from 00 to 23.

*mi* Specifies a number of minutes, in 2 decimal digits, from 00 to 59.

### UTC

Indicates that the time is coordinated universal time.

## SYSRESET

The system must be power-on reset in LPAR mode before sending a scheduled request for a secondary OCF. If it is not, the request is rejected.

When XBTIME is not accompanied by an XATIME, the command may be processed immediately.

### INTERVAL

Indicates that the associated command is to be processed repeatedly. It specifies the time span between processing repetitions. The specified value is added to XATIME, XBTIME, or both (if both are present in the command), to determine the next processing time.

*ddd*

Specifies a number of days, in 3 decimal digits, from 000 to 048.

*hh* Specifies a number of hours, in 2 decimal digits, from 00 to 23.

*mi* Specifies a number of minutes, in 2 decimal digits, from 00 to 59.

#### Notes:

1. The default, if INTERVAL is not explicitly stated, is one execution of the command.
2. INTERVAL is only valid if XATIME or XBTIME, or both, are also present in the command.
3. Within a given timing-window, there may be only one repetition of a command.

### COUNT

Specifies the number of times, based on specified timing controls, that processing of an operations command should be attempted. Timing controls are provided through the combined use of the XATIME, XBTIME, INTERVAL, and COUNT operands.

#### count-of-intervals

Is a decimal value, from 1 to 65535. This value indicates the maximum number of times that processing is to be attempted and is decremented after each processing attempt. When the count has been decremented to zero, the request is removed from the timed list.

The default value, if COUNT is not explicitly stated, is for the timing-window interval to be repeated forever, or until cancelled.

Use of the COUNT operand requires that INTERVAL, and a combination of either XATIME or XBTIME.

## Defaults

The SYSRESET command defaults to FORCE(NO) and to CLEAR(NO).

## Usage

Issue SYSRESET to recover a processor from a machine stop condition. This command places the processor into the operating state from the check-stop state.

If you do not specify FORCE(YES), the SYSRESET command checks to make sure it will not be disruptive by performing the following processing:

- If the target system runs in a logical partition and the same logical partition name is initialized to another target system in the same target hardware, the SYSRESET command is rejected and processing of the command halts.

- On a non-partitioned target system, if the target hardware has another target system initialized to it, the SYSRESET command is rejected and processing of the command halts.

**Specifying an SNMP timeout value**

For target hardware connections of type SNMP, the default timeout value of three minutes can be modified by setting the NetView task global variable ISQ.SNMP.WAIT to another value. The timeout format is *hh:mm:ss*, where *hh* represents the hours of the timeout, *mm* the minutes and *ss* the seconds of the period to wait for hardware command completion before terminating ISQCCMD. The value of the variable is checked each time a ISQCCMD request for a SNMP-connected target system is performed. If the timeout variable is not set, or its contents has an invalid format, the default value of three minutes is used. In the following REXX example a timeout value of 8 minutes and 30 seconds is set before calling ISQCCMD to perform an EXTERNAL interrupt hardware command.

```

/*REXX*/
tme = 'ISQ.SNMP.WAIT'           /* SNMP timeout varname */
mytgt = 'KEY6'                  /* our TGT system name */
Interpret tme=" '00:08:30'"     /* Set timeout to use */
'GLOBALV PUTT 'tme              /* Update task variable*/
Say 'SNMP Timeout value set to 'Tglobal(tme) /* Send info msg */
'ISQCCMD 'mytgt' EXTINT'       /* External irpt to Sys*/
If RC > 0 Then Do              /* Error occured */
End                             /* ...more to add */
Else Do                         /* All went well */
End                             /* ...more to add */

```

**Restrictions and Limitations**

This command is not supported for coupling facility target systems.

For SNMP-connected target hardware, the CLEAR parameter is supported by the zSeries processor family.

SNMP-connected target hardware cannot process the following parameters:

- INTERVAL
- XATIME
- XBTIME

The S, H, M timeout values of the FORCE parameter

**Return Codes**

The ISQCCMD command (described on page 297) generates the return codes for common command processing.

## SYSRESET

---

## Host-based Commands

---

### ISQCCMD

#### Purpose

The ISQCCMD command issues a common command.

#### Syntax

```
▶▶ ISQCCMD target_system_ProcOps_name common_command ▶▶
           |
           | group_name
           | subgroup_name
           | target_hardware_name
```

#### Requirements

Processor operations must be active.

The addressed target system must be initialized unless the specified common command is ACTIVATE (described on page 263).

#### Parameters

*target\_system\_ProcOps\_name*

Is the processor operations name of the target system.

*group\_name*

Is the name of the group of which subgroup(s) and target system(s) are members.

*subgroup\_name*

Is the name of the subgroup of which the target system(s) are members.

*target\_hardware\_name*

Is the name of the target hardware definition associated with the target system.

*common\_command*

Represents the common command and any associated parameters to be processed. Multiple parameters are separated from each other by a blank space.

#### Defaults

None.

#### Usage

Use the ISQCCMD command to issue a common command to the specified target system.

#### Restrictions and Limitations

- *Target\_hardware\_name* is valid only for the common command DEACTIVATE.
- *Group\_name* or *subgroup\_name* must be processor operations-enabled as defined in the SA OS/390 customization dialogs to be a valid parameter.

## ISQCCMD

### Specifying an SNMP timeout value

For target hardware connections of type SNMP, the default timeout value of three minutes can be modified by setting the NetView task global variable ISQ.SNMP.WAIT to another value. The timeout format is hh:mm:ss, where 'hh' represents the hours of the timeout, 'mm' the minutes and 'ss' of the period to wait for HW command completion before terminating ISQCCMD. The value of the variable is checked each time a ISQCCMD request for a SNMP connected target system is performed. If the timeout variable is not set, or its contents has an invalid format, the default value of three minutes is used.

In the following REXX example a timeout value of 8 minutes and 30 seconds is set prior calling ISQCCMD to perform an EXTERNAL interrupt hardware command:

```
/*REXX*/
tme = 'ISQ.SNMP.WAIT'                  /* SNMP timeout varname */
mytgt = 'KEY6'                          /* our TGT system name */
Interpret tme= '00:08:30'                /* Set timeout to use */
'GLOBALV PUTT 'tme                        /* Update task variable*/
Say 'SNMP Timeout value set to 'Tglobal(tme) /* Send info msg        */
'ISQCCMD 'mytgt' EXTINT'                  /* External irpt to Sys*/
If RC > 0 Then Do                         /* Error occurred       */
End                                         /* ...more to add      */
Else Do                                    /* All went well        */
End                                         /* ...more to add      */
```

### Return Codes

- 4 Command processing has been accepted.
- 8 Command processing has been rejected.
- 12 Command processing has failed.
- 32 The processor operations environment does not exist; the ISQCCMD command was not processed.

---

## ISQCHK

### Purpose

The ISQCHK command checks whether processor operations is active.

### Syntax

```
➔ ISQCHK ────────────┬───────────▶
                       |
                       | ┌──────────┐
                       | │  command_name  │
                       | └──────────┘
                       |
```

### Requirements

None.

### Parameters

*command\_name*

Is the name of an automation procedure.

### Defaults

None.

## Usage

This command is intended for use in automation procedures to determine whether processor operations is active. It provides a method of exiting from the automation procedure cleanly when processor operations is not active. If you issue ISQCHK from an operator station and processor operations is running, you will receive no response.

The optional *command\_name* parameter is placed in the text of the error message generated when processor operations is not active. This identifies the automation procedure that cannot run because processor operations is not active.

For example, place the following statements near the beginning of a processor operations automation procedure written in REXX:

```
'ISQCHK STARTALL'  
If RC<>0 then; Exit;
```

If you issue the STARTALL command when processor operations is not active, the error message will inform you that “the STARTALL command” cannot be run until processor operations is active, rather than simply informing you “the command” cannot be run until processor operations is active.

You can issue ISQCHK from an operator station task (OST) or from automation.

## Restrictions and Limitations

None.

## Return Codes

0	Processor operations is active.
32	Processor operations is not active.

---

## ISQCMON

### Purpose

The ISQCMON command causes the current NetView task to be added to or removed from the list of tasks to receive processor operations communications management messages.

### Syntax



### Requirements

None.

### Parameters

**ON**

Adds the current NetView task to the list of tasks to receive processor operations communications management messages. This is the default.

## ISQCMON

OFF

Removes the current NetView task from the list of tasks to receive processor operations communications management messages.

### Defaults

ISQCMON defaults to ON, adding you to the list.

### Usage

You can issue ISQCMON when processor operations is not running to add or delete yourself from the interested operators list for messages relating to the control of processor operations-managed resources. These messages are not associated with a specific target system.

Messages not associated with a specific target system are sent only to operators who used ISQCMON to place themselves on the interested operators list for such messages. These messages are not sent to the ISQXMON interested operator list. You are automatically added to the ISQCMON interested operator list when you issue the ISQSTART command (described on page 305).

Refer to *System Automation for OS/390 User's Guide* for further information about these two types of messages and interested operator lists.

### Restrictions and Limitations

Do not issue this command with ISQEXEC.

### Return Codes

- |   |   |
|---|---|
| 0 | The ISQCMON command completed successfully. |
| 8 | You used incorrect command syntax.          |

---

## ISQEXEC

### Purpose

The ISQEXEC command sends a command to a target control task to be processed. Commands sent by ISQEXEC are processed by the target control task in the order in which they are presented.

### Syntax

```
▶▶—ISQEXEC—target_system_name—

|    |
|----|
| SC |
| OC |

—command_name—▶▶
```

### Requirements

The requirements for this command to complete successfully are:

- Processor operations must be active.
- The target system specified with *target\_system\_name* must be initialized.

### Parameters

*target\_system\_name*  
Specifies the name of the target system.

**SC**  
Specifies the active system console connection.

**OC**  
Specifies the active operator console connection.

*command*  
Is the name of the user automation command to be processed.

## Defaults

None.

## Usage

The main advantage of the ISQEXEC command is that it frees the operator station task (OST) for other work because commands issued by ISQEXEC are processed by a target control task rather than in the OST.

You can require that a set of commands to a target connection are processed in the order in which the commands are presented (that is, serially). ISQEXEC is processed by a target control task, which ensures that the commands are processed in the correct order. A set of commands to be processed serially can be packaged in an automation procedure and be called by the ISQEXEC command, for example:

```
ISQEXEC target_system_name console_connection exec_name exec_operands
```

You can write automation procedures that issue ISQSEND commands. ISQSEND sends commands to a target system. You can enter the ISQEXEC command in the NCCF command line to cause an automation procedure to be processed.

## Restrictions and Limitations

The following restrictions or limitations apply to this command:

- Do not issue ISQXDST, ISQHELP, or ISQXOPT with ISQEXEC.
- Do not issue any user automation with ISQEXEC that results in a full-screen panel.
- ISQEXEC does not lock a target console connection; the serialized commands can be interrupted by commands from other tasks. See “Usage”.

## Return Codes

- |           |   |
|-----------|---|
| <b>0</b>  | The ISQEXEC command completed successfully and it caused the command to be queued to a target control task. |
| <b>8</b>  | The command syntax is not correct.  |
| <b>10</b> | The specified target system was not initialized.  |
| <b>12</b> | An internal error occurred.   |
| <b>32</b> | The processor operations environment does not exist. The ISQEXEC command was not processed.                 |

---

## ISQHELP

### Purpose

The ISQHELP command provides help on using processor operations commands.

## Syntax

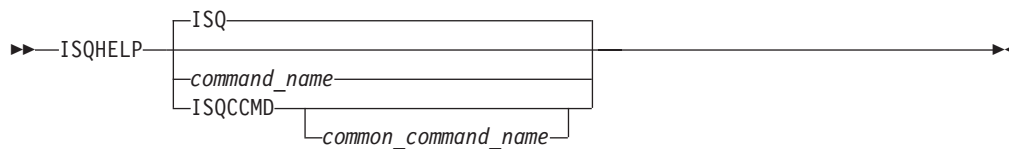

## Requirements

The NetView program must be running for this command to complete successfully.

## Parameters

### ISQ

Indicates the processor operations Main Help Panel is being requested. Not specifying any parameters with the ISQHELP command also presents the processor operations Main Help Panel.

### *command\_name*

Is the name of any parameter with which you need help. This can be a processor operations host-based or any parameter valid to the NetView help processor.

### ISQCCMD

Indicates that the variable following it is the name of a common command.

### *common\_command\_name*

Is the name of the common command for which you want help; only the first 3 characters of the common command need to be specified.

## Defaults

The processor operations Main Help Panel.

## Usage

The ISQHELP command does not require the processor operations environment.

Issue the ISQHELP command to obtain high-level information about processor operations, to obtain help about the syntax of a processor operations command, to obtain help with the output generated by the command, or to see examples of using the command.

Refer to *System Automation for OS/390 User's Guide* for further information on the ISQHELP command and for a description of other help functions.

## Restrictions and Limitations

The ISQHELP command cannot be issued from a program.

## Return Codes

Return codes are not applicable because the ISQHELP command cannot be issued from a program.

## ISQOVRD

### Purpose

The ISQOVRD command unconditionally removes a target console lock.

### Syntax

```

▶▶—ISQOVRD—target_system_ProcOps_name—▶▶
                                     OC
                                     SC
  
```

### Requirements

The requirements for this command to complete successfully are:

- The use of this command usually requires special authorization.
- Processor operations must be active.
- The *target\_system\_ProcOps\_name* syntax requires that the addressed target system be initialized.

### Parameters

*target\_system\_ProcOps\_name*

Is the name of the target system.

OC

Specifies the active operator console (not valid for the coupling facility).

SC

Specifies the active system console

### Defaults

None.

### Usage

The ISQOVRD command removes the console lock established by any command or automation procedure.

This command is intended to be used for emergencies only. Overriding a reserve can cause processing to fail, with unpredictable results.

### Restrictions and Limitations

The following restrictions or limitations apply to this command:

- This command does not establish a console lock for the issuing operator, it simply removes the lock on the console.
- This command does not interrupt or cancel any command or automation procedure currently running.

### Return Codes

- |   |  |
|---|--|
| 0 | The ISQOVRD command completed successfully; the lock has been removed.   |
| 4 | You used syntax that is not valid, specified a target system name that is not valid, or specified a target system that is not initialized. |

## ISQOVRD

- 8 A NetView CNMLOCK service problem occurred.  
32 The processor operations environment does not exist; the ISQOVRD command was not processed.
- 

## ISQSEND

### Purpose

The ISQSEND command sends a command to a target system for execution, using the processor operations target hardware connection and the console integration facility.

**Note:** This is an Application Programming Interface.

### Syntax

```
▶▶ [NVASIS] ISQSEND target_system_ProcOps_name [OC] [SC] command ▶▶
```

### Requirements

The requirements for this command to complete successfully are:

- Processor operations must be active.
- The addressed target system connection must have been initialized.

### Parameters

*target\_system\_ProcOps\_name*

Is the name of the target system.

OC

Specifies the active operator console.

SC

Specifies the active system console.

*command*

Is the command to be processed and any parameters associated with that command. These include processor commands and operating system commands. Use the ISQSEND command to send operating system commands and operations management commands. If you want to pass the command text in lower or mixed case, prefix the ISQSEND command with NETVASIS.

**Note:** Operations management commands, for example, PROFILE, or QUERY READ (CPCDATA) are only supported for NetView connections (NVCs). For further information, refer to *S/390 Managing your Processors*.

### Defaults

None.

### Usage

For target systems running on processors supported by processor operations, operating system commands can be entered through ISQSEND. The commands are transmitted to the operating system through console integration, an interface provided by the operating system and the processor hardware support element.

## Restrictions and Limitations

The following restrictions or limitations apply to this command:

- - With SA OS/390, the ISQSEND command is the only way to send data to the operating system of a target through the console integration connection. The information passed to the target system is not interpreted by SA OS/390.
- The successful ISQSEND completion does not indicate the successful completion of the command itself. It only indicates that the command was successfully delivered to the receiver. Your automation routines should interpret the asynchronous message responses of the command to determine the command execution results.
- Note, that the operating systems supporting console integration may have commands to activate or deactivate this functionality or may provide facilities and commands to prevent response messages from being routed to console integration. For MVS operating systems, the VARY CN(\*),DEACTIVATE / V CN(\*),ACTIVATE commands are available for console integration deactivation and reactivation.

## Return Codes

Return codes do not indicate whether messages were generated. You may receive an error message from the PC some time after the ISQSEND command completes with a return code of zero. This usually occurs when the ISQSEND command completes successfully, but what was issued by ISQSEND did not.

- |    |   |
|----|---|
| 0  | The ISQSEND command completed successfully and the message was sent.  |
| 8  | The message was not sent, the message was sent with errors, or the specified target system was not initialized. |
| 32 | The processor operations environment does not exist; the ISQSEND command was not processed.                     |

---

## ISQSTART

### Purpose

The ISQSTART command starts processor operations. It establishes the processor operations environment with the NetView program and permits the control of target systems with processor operations commands. This command can be issued from an automation routine.

### Syntax

```

▶▶—ISQSTART—┬──────────┬──────────┬──────────▶
               └──data_set_name──┘ └──DEBUG──┘
  
```

### Requirements

The NetView program must have at least read authority to the data set containing the control file.

You may need special authorization to use this command.

### Parameters

*data\_set\_name*

Is the name of the data set that contains the control file produced by the

## ISQSTART

customization dialogs Build Processor Control file function. It cannot be a partitioned data set (PDS) member. The control file is in a proprietary, non-readable format.

### DEBUG

Provides additional diagnostics, which are written to the NetView log.

## Defaults

There are no defaults for this command when processor operations is first started — you must provide the data set name for initial startup. When restarting, this command defaults to using the same data set specified the previous time the command was issued.

## Usage

To perform an initial start, specify a data set name. To perform a restart, do not specify a data set name. The data set name is specified with the configuration dialogs during installation or customization.

An initial start loads the specified configuration control file created with the configuration dialogs during installation and starts all processor operations tasks to establish the processor operations tasking environment. The configuration file also indicates which, if any, target systems and processor operations PCs should be initialized (not the IPL process), and indicates system console assignment for each target system.

In addition to starting processor operations initially, an initial start lets you change the processor operations configuration, by specifying a different data set name. (During installation, the installer may have gone through the configuration dialogs several times defining multiple processor operations configurations and generating a different control file for each.) To change the processor operations configuration, use the ISQSTOP command to stop processor operations before issuing the ISQSTART command with the data set name to initiate the initial start.

You usually do a restart after a processor operations task has failed to restart all processor operations tasks to re-establish the processor operations tasking environment. If the processor operations environment has not already been established by a previous ISQSTART command that specified a data set name, then the restart will fail.

When you issue ISQSTART, it adds you to the interested operators list accessed by the ISQCMON command. This list is for messages not associated with a specific target system. The messages relate to the control of processor operations-managed resources.

## Restrictions and Limitations

The following restrictions or limitations apply to this command:

- A restart re-establishes the previous configuration. The processor operations environment must exist (an initial start must have already been performed) before a restart can be performed.
- Processor Operations must be stopped before an initial start can be performed.
- The *data\_set\_name* cannot be DEBUG.
- The specified *data\_set\_name* must be a sequential data set.
- The DEBUG parameter is restricted to IBM service use only.

## Return Codes

0	Command accepted.
4	You used incorrect syntax.
8	An internal command error occurred.

---

## ISQSTOP

### Purpose

The ISQSTOP command stops processor operations. It can be issued in an automation routine.

### Syntax

```

▶▶ ISQSTOP [DEBUG]
  
```

### Requirements

You may require special authorization to use this command.

Processor operations must be active.

### Parameters

#### DEBUG

Provides additional diagnostics, which are written to the NetView log.

### Defaults

None.

### Usage

The ISQSTOP command immediately stops the processor operations environment and all processor operations tasks. If you do not have the shutdown of processor operations automated via SA OS/390, issue ISQSTOP and ISQSTART as part of normal shutdown procedures to restart failed processor operations tasks or to establish a new operating environment (see the ISQSTART command).

### Restrictions and Limitations

The ISQSTOP command does not shut down target systems.

All current processor operations status information is lost when you issue ISQSTOP. You should exit any displays presented by the ISQXDST, or ISQXOPT commands before stopping processor operations.

### Return Codes

0	The ISQSTOP command completed successfully.
4	You used incorrect syntax.
8	An internal command error occurred.
32	The processor operations environment does not exist; the ISQSTOP command was not processed.

## ISQVARS

### Purpose

The ISQVARS command lets you view and change certain SA OS/390 values. Table 5 on page 315 identifies the keywords for the values you can view or change with the ISQVARS command.

### Syntax

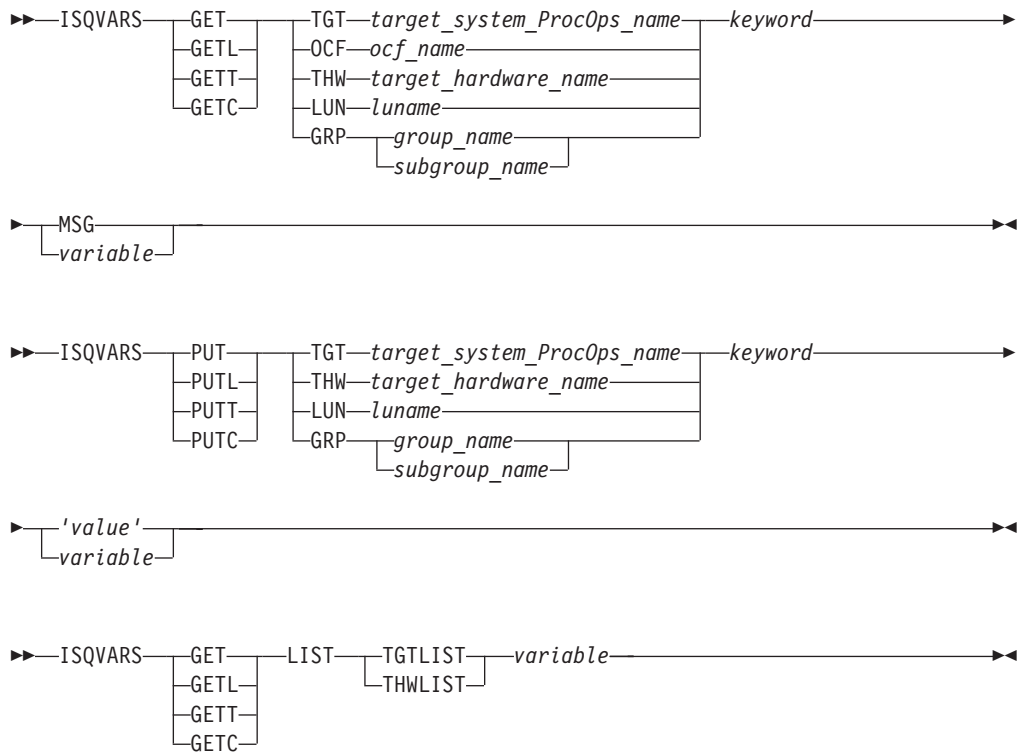

### Requirements

Processor operations must be active.

### Parameters

#### GET

Specifies that you want to retrieve the value of a SA OS/390 keyword to be displayed or to be placed into a specified NetView® local variable.

#### GETL

Specifies that you want to retrieve the value of a SA OS/390 keyword to be displayed or to be placed into a specified NetView local variable. This keyword is the same as the GET keyword. This is the default if you specify GET.

#### GETT

Specifies that you want to retrieve the value of a SA OS/390 keyword to be displayed or to be placed into a specified NetView task variable.

#### GETC

Specifies that you want to retrieve the value of a SA OS/390 keyword to be displayed or to be placed into a specified NetView common variable.

**TGT**

Indicates that the variable following it is the name of the target system.

*target\_system\_ProcOps\_name*

Is the name of the target system.

**OCF**

Indicates that the variable following it is the name of the target system's secondary operations command facility (OCF). A secondary OCF is used on an OCF-based processor in LPAR mode to represent a logical partition and to process commands for that CPC image (logical partition). The name of the secondary OCF is specified on the "Target System Description" panel for OCF-based processors in the configuration dialogs. On a System/390<sup>®</sup> microprocessor cluster, the name of the secondary OCF is the same as the name of the logical partition and of the Image profile used to activate the partition.

*ocf\_name*

Is the name of the target system's secondary OCF.

**THW**

Indicates that the variable following it is the name of the target hardware.

*target\_hardware\_name*

Is the name of the target hardware.

**LUN**

Indicates that the variable following it is the logical unit name.

*luname*

Is the logical unit name.

**GRP**

Indicates that the variable following is a group or subgroup name.

*group\_name*

Is the name of the group of which the subgroup is a member.

*subgroup\_name*

Is the name of the subgroup of which the target system is a member.

*keyword*

Is the name of the SA OS/390 value to be retrieved or set. Table 5 on page 315 identifies the SA OS/390 values that can be read or changed by the ISQVARS command.

**MSG**

Indicates the SA OS/390 value is to be displayed on the console as line-mode output.

*variable*

Is the name of the NetView variable whose value is to be set to that of the specified SA OS/390 keyword. Local variable names are most commonly used when values are being read and written from within automation procedures. The names of the SA OS/390 values are defined in Table 5 on page 315.

**PUT**

Specifies that you want to set the value of a SA OS/390 keyword to either the current value of a specified NetView local variable or to a value specified in the command string.

**PUTL**

Specifies that you want to set the value of a SA OS/390 keyword to either the

## ISQVARS

current value of a specified NetView local variable or to a value specified in the command string. This keyword is the same as the PUT keyword. This is the default if you specify PUT.

### PUTT

Specifies that you want to set the value of a SA OS/390 keyword to either the current value of a specified NetView task variable or to a value specified in the command string.

### PUTC

Specifies that you want to set the value of a SA OS/390 keyword to either the current value of a specified NetView common variable or to a value specified in the command string.

### TGT

Indicates that the variable following it is the name of the target system.

*target\_system\_ProcOps\_name*

Is the name of the target system.

### THW

Indicates that the variable following it is the name of the target hardware.

*target\_hardware\_name*

Is the name of the target hardware.

### LUN

Indicates that the variable following it is the logical unit name.

*luname*

Is the logical unit name.

### GRP

Indicates that the variable following is a group or subgroup name.

*group\_name*

Is the name of the group of which the subgroup is a member.

*subgroup\_name*

Is the name of the subgroup of which the target system is a member.

### *keyword*

Is the name of the SA OS/390 keyword whose value is to be retrieved or set. Table 5 on page 315 identifies the values that can be read or changed by the ISQVARS command.

### *'value'*

Is the value to be assigned to the SA OS/390 keyword. The straight single quotation marks are required.

### *variable*

Is the name of the NetView variable which contains the value to which the SA OS/390 keyword is to be set (PUT). Local variable names are most commonly used when SA OS/390 values are being read and written from within automation procedures. The keywords used for SA OS/390 values are defined in Table 5 on page 315.

### LIST

Indicates the keyword following it identifies which list is being referenced. This keyword is valid from automation programming only.

### TGTLIST

Refers to the list of defined target system names.

**THWLIST**

Refers to the list of defined target hardware names.

*variable*

Is the name of the NetView variable whose value is to be set to that of the specified SA OS/390 keyword. Local variable names are most commonly used when values are being read and written from within automation procedures. The names of the SA OS/390 values are defined in Table 5 on page 315.

**Defaults**

None.

**Usage**

There are several ways to specify the desired information:

**Target system name**

```
get|put TGT target_system_ProcOps_name keyword...
```

**Target hardware name**

```
get|put THW target_hardware_name keyword...
```

**Group name**

```
get|put GRP group_name keyword...
```

**Subgroup name**

```
get|put GRP subgroup_name keyword...
```

**LU name**

```
get|put LUN luname keyword...
```

**OCF name**

```
get OCF ocf_name keyword...
```

**Return a list**

```
get LIST keyword...
```

You can display (on the NetView console) the value of a NetView variable by using the MSG keyword.

The ISQVARS command allows access to SA OS/390 values. Values relating to target systems, PCs, or ports require the name of the component (target system processor operations name, PC name, or port name). The *keyword* is a processor operations-defined character string identifying the name of the processor operations value.

If issued from a program, a NetView variable is specified to contain the SA OS/390 value.

- In the GET case, the specified NetView variable (*variable*) is set to the specified SA OS/390 value (*keyword*).
- In the PUT case, the specified SA OS/390 value is set to the current value of the specified NetView variable, or to the value specified within straight single quotation marks.

For example, assume target system names *system1*, *system2*, and *system3* have been defined. The following command:

```
ISQVARS GET LIST TGTLIST TARGETS
```

will place the following character string into the NetView local variable *targets*:  
system1 system2 system3

## Restrictions and Limitations

The following restrictions or limitations apply to this command:

- SA OS/390 values are defined through the use of configuration panels during installation. Not all of these values can be changed by the ISQVARS command. Table 5 on page 315 identifies the SA OS/390 values that can be changed by the ISQVARS command.
- Any changes you make to a SA OS/390 value with the ISQVARS command remain in effect only for the current session of SA OS/390. Stopping and then starting SA OS/390 resets the variables.
- GET LIST is valid only from within automation programming. You cannot issue GET LIST from an OST.
- GET LIST has the following length restrictions:
  - The NetView variable is restricted to 32767 bytes when a REXX command processor calls the ISQVARS command using the NetView *local* variable form (GET|GETL LIST). The ISQVARS command truncates the data to this length if necessary.
  - The NetView variable is restricted to 255 bytes when a REXX command processor, high-level language, or NetView command list calls the ISQVARS command using the NetView *task* variable form or NetView *common* variable form (GETT|GETC LIST). The ISQVARS command truncates the data to this length if necessary.

**Caution:** Use ISQVARS with care. Value changes are made immediately and may seriously affect the running of SA OS/390.

## Return Codes

0	Processed without errors.
30	The processor operations environment does not exist; the ISQVARS command was not processed.
32	The processor operations environment does not exist; the ISQVARS command was not processed.
131	You did not enter enough parameters.
132	The second argument you specified is unknown.
133	You specified a form of the command that is not valid with the <i>list</i> option.
134	<i>msg</i> and <i>list</i> options are mutually exclusive.
135	Neither get nor put were specified.
136	You used an uneven number of single straight quotation marks.
137	You used single straight quotation marks other than for the last argument.
138	Unable to write to the specified variable.
139	Unable to read the specified variable.
140	The PUT function completed successfully.
141	<i>msg</i> is a keyword and cannot be used as a variable name.
142	Variable answer could not contain all of the data, variable truncated to 255 bytes.
143	Variable answer could not contain all of the data, variable truncated to 32767 bytes.
144	Addressed port not initialized to a target system.
145	System console not defined for addressed target system.
161	You specified a target hardware name that is not valid.
162	You specified an unknown keyword.
163	You specified a target system name that is not valid.
166	You specified a keyword restricted to LPAR systems.
167	The specified port is not connected to an operator console.
168	The specified port is not connected to a system console.

- 169 IOCDs cannot be located, system is in LPAR mode.
- 170 The port definition and the target hardware definition in the SA OS/390 configuration panels conflict with one another — the system console cannot be found.
- 171 The port definition and the target hardware definition in the SA OS/390 configuration panels conflict with one another — the operator console cannot be found.
- 172 You specified a keyword that is not valid for the PUT function.
- 173 NetView CNMLOCK failure.
- 174 Internal locking sequence error.
- 175 Unable to obtain lock for PUT function.
- 176 You specified a PUT function with non-hexadecimal characters for a keyword field that can contain only hexadecimal characters; the command is ignored.
- 177 You specified a PUT function with non-integer characters for a keyword field that can contain only integer characters; the command is ignored.
- 178 Unknown operating system type for specified target system.
- 179 The specified keyword only valid if the addressed target system is running the MVS or VM operating systems.
- 182 You tried to write (PUT) values to a keyword field that are not valid values for that field.
- 183 You tried to write (PUT) a value that is too large for the keyword field to which it is being written.
- 184 You tried to write (PUT) a time offset value that is not valid.
- 185 You specified a parameter that cannot be used with the keyword you specified (the parameter values that can be specified are *list*, *tgt*, or *thw*).
- 186 It is not valid to change the internal variable you specified from its current status value to the status value you specified.
- 187 You cannot use the ISQVARS command to change the current value of the specified internal variable.
- 188 It indicates that the status of the target system or logical partition cannot be identified.
- 189 You specified a logical partition name that is not valid.
- 191 You specified a variable that requires a qualified name (such as *target.lpar*), but the qualified name you provided is not valid.
- 192 Logical partition name missing. You specified a target hardware name, but it was not followed by a logical partition name (such as *target.lpar*).
- 193 The memory requested is larger than the maximum that can be installed.
- 194 The system name entered is not a valid target system name, but it is a valid target hardware name.

## Authorization

SA OS/390 provides keywords you can use to define your configuration and to determine the status of the elements in your configuration.

When you develop automation routines, you need to read these keyword values and perhaps write to them as well. For example, a routine may change the primary IPL address used by automation. Assuming the old address was 03FE, the following command changes the address to 0123:

```
ISQVARS PUT TGT SILVER pip1a '0123'
```

This section explains the keywords and the valid values each keyword accepts. It also identifies the SA OS/390 messages that trigger SA OS/390 automation to update the keyword values. You may want to use these status messages to begin your own automation routines.

## ISQVARS

### Variable Value Lengths

In addition to using the correct form of ISQVARS for the variable type, you must be aware of the length limits of variables for your particular programming environment. This is a particular concern when you are retrieving long data strings such as lists of defined target systems. If you are programming in REXX, the variable value length limit is 32 KB. For other programming environments supported by NetView, the variable value length limit is 256 bytes.

### Keyword Valid Values

This column shows the values of SA OS/390 keywords. You can retrieve or change these values by use of the ISQVARS command if they are valid values.

In Table 5, the SA OS/390 values are sorted according to the contents of the *Name* column, which identifies the keyword name of the value. The column *Access* indicates the type of access allowed for the keyword through the ISQVARS command. A keyword may have either read-only access, designated by *read* (GET), or read/write access, designated by *write* (PUT).

The column **ISQVARS** indicates which command keyword you should use after the GET or PUT keyword of the ISQVARS command to access the SA OS/390 value.

## SA OS/390 Keywords and Status Messages

Table 5 lists the ISQVARS keywords sorted by keyword name.

Table 5. ISQVARS Keywords Sorted by Keyword Name

Keyword Description	Name	Access	ISQVARS	Valid Values and Comments
Last activated THWNAME	acthw	write	LUN	Allows the obtaining or setting of the last target hardware (THWNAME) to be activated for a specified LUNAME corresponding to a NetView Connection Path. The setting of the THWNAME needs to be done before the THWNAME can be obtained. If PUT specified, input must be equal to a valid THWNAME.
THW: active target system name	atsname	read	OCF or THW	When OCF, name of active target system associated with OCF. When THW, name of active target system initialized on the specified target hardware; one name for XA, ESA, and 370, multiple names for LPAR-mode target hardware.
Backup focal point	backfp	read	THW	Backup focal point NetView domainid
Target hardware connection type	ctype	read	THW	Type of processor operations NVC or SNMP to focal-point NetView
IPL message: response to duplicate volume IEA212A IPL message	dvol	write	TGT	A list of zero to 12 three-digit hexadecimal control unit addresses, separated from each other by one or more blanks. These addresses identify the devices to be left online (MVS only).
Group name list	grplist	read	GET LIST	A list of group names. The names are separated by one or more blanks.
Hardware Management Console Address	hmcaddr	read	THW	IP address or hostname of a HMC where the THW is defined.
Target hardware processor type	htype	read	TGT or THW	9672, 9674, 3000, 2003, eServer, or zSeries machine type nbr
LPAR: partition initial state	ilpars	read	TGT	ACTIVE or INACTIVE (LPAR target systems only).
IPL message: response to master catalog action IEA347A IPL message	iplmsgmc	write	TGT	75 characters (MVS only).
IPL message: response to IEA101A IPL message	iplmsgsp	write	TGT	75 characters (MVS only).
IPL message: VM IPL start message	iplmsgvm	write	TGT	75 characters (VM only).
LPAR: partition name in use?	lparact	read	THW	Null (not logically partitioned) or name of the initialized target system that has the specified LPAR name, in the form <i>target_hardware_name.LPAR_name</i> . The variable contains the name of the initialized target system that has LPAR name or a null value if none of the target systems initialized to the target hardware have that LPAR name.
NetView connection path LUNAME	nplu	read	TGT or THW	SNA LUNAME for connection to an OCF-based processor support element

## ISQVARS

Table 5. ISQVARS Keywords Sorted by Keyword Name (continued)

Keyword Description	Name	Access	ISQVARS	Valid Values and Comments
NetView connection path NETID	npnetid	read	TGT or THW	SNA NETID for connection to OCF-based processor support element
NetView connection path Target Hardware Names	npthw	read	LUN	Returns all defined target hardware names for an NVC/SNMP connection.
NetView connection status summary	nvcs	write	THW	Valid values are: NVC SESSION PROBLEM, ACTIVE, NVC SESSION BUSY, SNMP SESSION PROBLEM or blank.  For read, you may also get CLOSED and DORMANT in addition to the values that you can write.
Operator console lock	oclockn	read	TGT	Name of operator who issued the lock; blank if not set.
Operator console status	ocstat	read	TGT	ACTIVE, CLOSED, UNKNOWN, LINK ERROR, UNDEFINED, and CONSOLE LOST
Target operating system type	ostype	read	TGT	MVS, VM, LINUX, VSE, or CF
IPL: primary IPL address	pipla	write	TGT	Specifies the device address to be used for the IPL
IPL: primary IPL CP address	piplcpua	write	TGT	Specifies the central processor address (no longer used).
IPL: primary IPL parameter	piplp	write	TGT	8 characters allowed.
LPAR: partition status	pnstatus	write	TGT	I (inactive) or A (active).
Primary focal point	primfp	read	THW	Primary focal-point NetView domainid.
Subgroup name list	sbglst	read	GET LIST	A list of subgroup names. The names are separated by one or more blanks.
System console lock	sclockn	read	TGT	Name of operator who issued the lock; blank if not set.
System console status	scstat	read	TGT	NVC SESSION BUSY, NVC SESSION PROBLEM, SNMP SESSION PROBLEM, ACTIVE, CLOSED, DORMANT, and blank.
Support Element address	seaddr	read	THW	IP address or hostname of THWs Support Element
LPAR: partition automatic IPL	taipl	write	TGT	Y or N.
Target system attention	tattn	write	TGT	Blank, DCCF, EXCEPTIONS, DISABLED WAIT.
Authorization token	tauth	read	TGT or THW	Authorization token or SNMP community name of the processor support element or HMC.
Target system description	tdesc	read	TGT	
Desired Image profile	tdipf	write	TGT	Desired Image profile name for the specified target system name.
Desired Load profile	tdlpf	write	TGT	Desired Load profile name for the specified target system name.
Desired Reset profile	tdrpf	write	TGT	Desired Reset profile name for the specified target hardware name.
Status Panel Error Message	temsg	write	TGT or THW	Status panel error message line.

Table 5. ISQVARS Keywords Sorted by Keyword Name (continued)

Keyword Description	Name	Access	ISQVARS	Valid Values and Comments
Target System Group name	tgrp	read	TGT or GRP	Target system names within a group and subgroup(s) associated with this group or the group name(s) for a target system.
Target system name list	tgtlist	read	GET LIST	A list of target system names. The names are separated by one or more blanks.
Target hardware name list	thwlist	read	GET LIST	A list of target hardware names. The names are separated by one or more blanks.
Target hardware name	thwname	read	TGT	Name of target hardware definition associated with the specified target system.
Target hardware status	thwstat	write	TGT	Blank, LPAR DEFINITION PROBLEM, TARGET HARDWARE PROBLEM, POWERED OFF, and POWER-ON RESET REQUIRED.
Target time offset	timeoff	write	TGT	A number in the range of -23 through +23 the TGT time deviates frm FP.
Status Panel Info Message	timsg	write	TGT or THW	Status panel informational message line.
Target system initialized?	tinit	read	TGT	YES or NO
LPAR: partition name	tlpar	read	TGT	Null or LPAR name for the specified target system if the target system is not in an LPAR. Use the TGT form of the command.
Target system mode	tmode	read	TGT	ESA, LINUX, or CF.
Target system console status summary	toca	read	TGT	Blank.
Target system console status summary	tocb	read	TGT	Blank.
Target system console status summary	tsca	read	TGT	Blank.  SNMP SESSION PROBLEM, NVC SESSION BUSY, and NVC SESSION PROBLEM
Target system console status summary	tscb	read	TGT	Blank.
Target system name	tsname	read	THW or OCF	When THW, names of all defined target systems on specified target hardware name, whether initialized or not (one name for XA, ESA*, and 370, multiple names for LPAR-mode target hardware).  When OCF, the target system name associated with a secondary OCF name.
Target system status	tstat	write	TGT	UNKNOWN, INITIALIZED, IPL COMPLETE, LOAD FAILED, IPL FAILED, CLOSED, WAITING FOR IEA101A MESSAGE, WAITING FOR IEA347A MESSAGE, WAITING FOR VM START MESSAGE, STAGE-1 ACTIVATE COMPLETE and NOT ACTIVE.
Target System SubGroup name	tsubgrp	read	TGT or GRP	Target system names within a subgroup or the subgroup name(s) for a target system.
Group processor operations-enabled indicator	vgrp	read	GET	Y or N.

## ISQVARS

Table 5. ISQVARS Keywords Sorted by Keyword Name (continued)

Keyword Description	Name	Access	ISQVARS	Valid Values and Comments
Subgroup processor operations-enabled indicator	vsubgrp	read	GET	Y or N.

**ISQVARS Resource Type:** The ISQVARS command syntax also includes a resource type. Use the correct resource type (TGT, THW, LIST, PUT LUN, or PUT GRP) for the requested keyword.

### Automation from Status Messages

When SA OS/390 processor operations detects a status change for any element of your SA OS/390 configuration, it updates the appropriate status table variables and may generate a message or an alert. You can create a routine and a NetView automation table entry to automate the operator response to these status change messages. For the recommended operator response to each of these messages, refer to *System Automation for OS/390 Messages and Codes*.

---

## ISQXCLS

### Purpose

For a screen-oriented processor the ISQXCLS command closes a target system or some part of the processor operations environment. Closing a target system automatically closes the system console (if there are no other active logical partitions) and operator console ports and sets the target system status to CLOSED.

### Syntax

►►—ISQXCLS—*target\_system\_ProcOps\_name*—►►  
  OC  
  SC

### Requirements

The requirements for this command to complete successfully are:

- Processor operations must be active.
- The *target\_system\_ProcOps\_name* syntax requires the addressed target system to be initialized.
- No console connection to be closed can be locked by another task.

### Parameters

*target\_system\_ProcOps\_name*

Is the name of the target system to be closed.

OC

Specifies the active operator console connection.

SC

Specifies the active path for an SNMP or NVC connection.



## ISQXDRL

- You must be on the interested operators list for the operator console to see the reply messages.

### Parameters

*target\_system\_ProcOps\_name*

Is the name of the target system. It is a required parameter, and must be a valid target system name.

### Defaults

None.

### Usage

The ISQXDRL command provides a convenient alternative to using the pass-through facility to issue the MVS D R,L command.

Each line of the MVS response to the D R,L command is displayed as a single-line message. Processor operations does not trap the responses. There is no prefix to the message lines and the last line is followed by a line of dashes. Other messages to the operator may be interspersed with these messages, especially for the last line of dashes. The line of dashes may be issued some time after the last real line of output from the MVS command.

### Restrictions and Limitations

The ISQXDRL command works only when issued to systems running MVS.

### Return Codes

- |    |   |
|----|---|
| 0  | The ISQXDRL command completed successfully.   |
| 4  | You used syntax that is not valid, specified a target system that is not running MVS, or specified a target system that is not initialized. |
| 8  | A problem occurred during the processing of the ISQSEND command or the console is locked by another task.                                   |
| 32 | The processor operations environment does not exist; the ISQXDRL command was not processed.   |

---

## ISQXDST

### Purpose

The ISQXDST command displays status panels, which provide the following information:

- Status summary (all target systems)
- Individual target hardware status
- Individual target system status
- Connection path status
- Interested operator list

### Syntax

→ ISQXDST target\_system\_ProcOps\_name →

## Requirements

Processor operations must be active.

## Parameters

*target\_system\_ProcOps\_name*

Is the name of a valid target system for which you want to see individual target system status. If omitted, the summary status of all target systems is displayed.

See “Examples” on page 322 for a description of the status values for target systems.

## Defaults

The status summary panel that shows the overall status of all target systems.

## Usage

Issue the ISQXDST command from an operator console to access the processor operations status facility. If you issue the command to access the status summary panel, you will be able to use the status facility to view multiple panels for multiple target systems without exiting the status facility. Refer to *System Automation for OS/390 Defining Automation Policy* and to *System Automation for OS/390 User's Guide* for more information about how to set up and use the status facility.

To display the Status Summary, issue:

```
ISQXDST
```

To display the status of a specific target system, issue:

```
ISQXDST target_system_ProcOps_name
```

If you enter the status facility by issuing the ISQXDST command with no other parameters, all of the status panels give you access to the other status panels supported by the status facility. Some of these status panels cannot be directly accessed by command. Refer to *System Automation for OS/390 User's Guide* for further information about how to use the status panels.

## Restrictions and Limitations

The following restrictions or limitations apply to this command:

- Do not issue this command with ISQEXEC or from an automation procedure.
- You can issue the ISQXDST command only from an operator console.

## Return Codes

Return codes are not applicable because the ISQXDST command cannot be issued from a program.

## Examples

```

ISQESUM          SA OS/390 Status Summary    Updates: Static

Place cursor on desired system and press PF key for more details

Target System Name  Status

KEYCF              UNKNOWN
KEY1               SESSION PROBLEM
KEY2               SESSION PROBLEM
KEY3               INITIALIZED
KEY4               INITIALIZED
KEY5               INITIALIZED
KEY6               INITIALIZED
PIRAN1             NVC SESSION PROBLEM
PIRAN2             NVC SESSION PROBLEM
PIRAN3             NVC SESSION PROBLEM

Enter=Dynam  PF1=Help PF3=Exit PF4=Target System Summary PF5=Resource
PF6=Roll    PF7=Up   PF8=Down PF9=Target Hardware Summary PF12=Quit

```

Figure 136. ISQXDST Status Summary Panel

The following values can be displayed on the ISQXDST panel to describe the status of target systems:

### **CLOSED**

(green) The target system has been closed.

### **INITIALIZED**

(green) The target system has been successfully initialized.

### **IPL COMPLETE**

(green, yellow, or red) For a TPF or VSE system, the Load or Load Clear process started. For an MVS system, processor operations automation responded to the IEA347A message. For a VM system, processor operations automation responded to the VM start message. If this condition is displayed in red, this is to attract your attention to the fact that something is wrong (such as processor operations lost its communication link with the target system) rather than that the IPL process failed. This condition will revert to being displayed in green when the problem is corrected.

### **STAGE-1 ACTIVATE COMPLETE**

(yellow) The support element power-on reset has occurred but the load is not yet complete.

### **NOT ACTIVE**

(yellow) Activate response was received from the target and did not indicate that stage-1 activation was completed.

### **IPL FAILED**

(red) MVS only — Error messages were generated during the initial program load process.

### **LOAD FAILED**

(red) The Load or Load Clear operation did not complete successfully.

**UNKNOWN**

(green) No attempt has been made to initialize or activate this target system. This status can be set only by a cold start of processor operations.

**WAITING FOR IEA101A START MESSAGE**

(yellow or red) MVS only: ACTIVATE, ISQXIPL, or ISQXLOD command processing has completed for an MVS system and processor operations is waiting for the IEA101A message on the operator console. If this condition is displayed in red, this is to attract your attention to the fact that something is wrong (such as processor operations lost its communication link with the target system) rather than that processor operations has been waiting for the message too long.

**WAITING FOR IEA347A MESSAGE**

(yellow or red) MVS only: processor operations has replied to the IEA101A message and is waiting for the IEA347A message on the operator console. If this condition is displayed in red, this is to attract your attention to the fact that something is wrong (such as processor operations lost its communication link with the target system) rather than that processor operations has been waiting for the message too long.

**WAITING FOR VM START MESSAGE**

(yellow or red) VM only: processor operations is waiting for the first VM IPL message on the operator console. ISQXLOD, ISQXIPL, or ACTIVATE command processing has completed for a VM system and processor operations is waiting for the first VM IPL message on the operator console. If this condition is displayed in red, this is to attract your attention to the fact that something is wrong (such as processor operations lost its communication link with the target system) rather than that processor operations has been waiting for the message too long.

**ISQXIII****Purpose**

The ISQXIII command initializes (or re-initializes) a target system, or a target system connection. When initializing a target system, ISQXIII establishes a connection to the target processor and enables its console connections.

**Syntax**

►►—ISQXIII—*target\_system\_ProcOps\_name*—►►

OC
SC

**Requirements**

The requirements for this command to complete successfully are:

- Processor operations must be active.
- The addressed target system must have a status of UNKNOWN or CLOSED.
- The addressed target system must be initialized if you use the *target\_system\_ProcOps\_name console\_designator* syntax.
- No associated console connection can be locked by another task.

## Parameters

*target\_system\_ProcOps\_name*

Is the name of the target system. This is a required parameter, and must be a valid target system name.

**OC**

Specifies the active operator console (not valid for the coupling facility).

**SC**

Specifies the system console connection.

## Defaults

None.

## Usage

Issue the ISQXIII command to a target system to prepare it for processor operations monitoring and control.

### Initializing a Target System

Initializing a target system starts communication with the target hardware and enables the console connections. It also updates the interested operator lists for consoles at the target system. The interested operator lists are updated because an operator can join an interested operator list by issuing the ISQXMON command after processor operations has been started but before the target system has been initialized.

The ACTIVATE common command initializes a target system and is associated console connections as part of their larger procedures.

## Restrictions and Limitations

The following restrictions or limitations apply:

- To re-initialize a target system, you must first close it with the ISQXCLS command (described on page 318).
- To initialize a console connection, the target system must have been initialized previously.

## Return Codes

- |    |   |
|----|---|
| 0  | The ISQXIII command processed successfully and the processor operations environment for the specified target system has been initialized or re-initialized.   |
| 4  | During initialization of a target system one or more of the following problems occurred: <ul style="list-style-type: none"> <li>• No system consoles could be contacted.</li> <li>• No operator consoles could be contacted.</li> </ul> |
| 8  | You used syntax that is not valid, specified a target system that is not initialized.   |
| 12 | An internal error occurred.   |
| 16 | A severe error occurred.  |
| 32 | The processor operations environment does not exist; the ISQXIII command was not processed.   |

## ISQXLOC

### Purpose

The ISQXLOC command locks access to a console to serialize operations to that console with other operator tasks.

### Syntax

```
▶▶—ISQXLOC—target_system_ProcOps_name—OC  
SC—▶▶
```

### Requirements

The requirements for this command to complete successfully are:

- Processor operations must be active.
- The console must not be locked by another task.

### Parameters

*target\_system\_ProcOps\_name*

Is the name of the target system.

**OC**

Specifies the active operator console (not valid for the coupling facility).

**SC**

Specifies the active system console (not valid for the OCF-based processors).

### Defaults

None.

### Usage

All processor operations commands that require serialization automatically lock the console when they start and unlock the console when they complete.

The lock is a logical entity that prevents processor operations operations from being sent to the console—they are rejected unless issued by the same task that issued the ISQXLOC command—until the lock is removed by the ISQXUNL command (described on page 330).

If you are going to issue several commands to a target system, you can issue the ISQXLOC command to lock access to the console to ensure the commands are processed without interruption by commands from other tasks. When you are finished with this sequence of commands, issue the ISQXUNL command to unlock access to the console.

If the ISQXLOC command is issued within an automation procedure, or within a set of called automation procedures, then the locked console should be unlocked (using the ISQXUNL command) after all processing of the automation procedure is completed. It is not normally necessary to lock a console for the processing of an automation procedure because of the serialization of the ISQEXEC command.

Any change in lock status is reflected in the status facility.

## ISQXLOC

### Restrictions and Limitations

The following restrictions or limitations apply to this command:

- The parameters are not checked for validity.
- Once obtained by a task, another task cannot obtain the lock until it is released by the owning task.
- An ISQXLOC command issued from within a locked sequence of commands is rejected.

### Return Codes

- |    |  |
|----|--|
| 0  | The ISQXLOC command completed successfully.  |
| 4  | The console was already locked by the current task.  |
| 8  | You used syntax that is not valid, specified a target system name that is not valid, or specified a target system that is not initialized. |
| 12 | The console is locked by another task.   |
| 32 | The processor operations environment does not exist; the ISQXLOC command was not processed.  |

Return codes greater than 8 not listed above — an error occurred in the NetView CNMLOCK service.

---

## ISQXMON

### Purpose

The ISQXMON command adds you to or deletes you from the interested operator list for a port or a target system console. When added, you can monitor a console and receive all message traffic for that console.

### Syntax

```
▶▶—ISQXMON—target_system_ProcOps_name—

|       |
|-------|
| OC=ON |
| SC    |

—

|     |
|-----|
| ON  |
| OFF |

▶▶
```

### Requirements

Processor operations must be active.

### Parameters

*target\_system\_ProcOps\_name*

Is the name of the target system you want to monitor. The name must be a valid target system name.

**OC**

Specifies the operator console connection (not valid for the coupling facility).

**SC**

Specifies the system console onnection.

**ON**

Indicates you are to be added to the list of interested operators.

**OFF**

Indicates whether you are to be deleted from the list of interested operators.

## Defaults

None.

## Usage

If you are using the NVC or SNMC connections, the console integration messages will be routed to the SC list and *not* the OC list.

The ISQXMON command may be issued at any time after processor operations has been started. It does not require that the target system is active.

Interested operator lists are maintained by console connection. There are two lists for each target system — one for the operator console and one for the system console. The maximum number of interested operators is 12 per console (but only 10 can be specified through the configuration dialogs).

**Note:** VSE operating in the unattended node support mode suppresses messages to the operator console. See the *VSE/SP Unattended Node Support* and *VSE/ESA™ 1.1.0 Unattended Node Support* books for more information about VSE operating in this mode.

Specifying the system console of a logically partitioned system means you will see messages for all target systems running on that target hardware. Conversely, you must issue ISQXMON OFF for the system consoles of all target systems running on the logically partitioned hardware to stop receiving any traffic through that port because the other logical partitions are using the same system console connection.

You will receive only one copy of a message generated by target hardware, even if you are on multiple lists for logically partitioned target hardware (each of the target systems on that hardware).

## Restrictions and Limitations

The following restrictions or limitations apply:

- If several target systems have the same port defined as their system console (for example, in a PR/SM™ system), and you issue ISQXMON ON for the system console of one of those targets, you receive all messages from the port.
- Similarly, if you issue ISQXMON OFF for the system console of one of the target systems that is not logically partitioned, you cease to receive any messages from that port. If you issue ISQXMON OFF for the system console of one of the logically partitioned target systems, you receive messages from that logical partition because other logical partitions are using the same port. You will continue to monitor all traffic for that console until you have issued ISQXMON OFF for all of the logical partitions using that port.
- There is a maximum of 12 interested operators per console.
- A NetView group name cannot be added or removed from a list with the ISQXMON command.
- There can be no more than 256 unique operator names in all interested operator lists.

## Return Codes

- 0 The ISQXMON command processed successfully. The operator issuing the ISQXMON command has been added to or deleted from the interested operators list of the specified console, as requested.
- 4 You specified incorrect command syntax.

## ISQXMON

- 6 The interested operator list is full.
- 8 You specified a NetView group name for the list to which you want to be added as an interested operator.
- 16 An internal error occurred.
- 32 The processor operations environment does not exist; the ISQXMON command was not processed.

---

## ISQXOPT

### Purpose

The ISQXOPT command displays target system information. Some information can be changed at this panel.

### Syntax

►►—ISQXOPT—*target\_system\_ProcOps\_name*—◄◄

### Requirements

Processor operations must be active.

### Parameters

*target\_system\_ProcOps\_name*

Is the name of the target system. It must be a valid target system name of 8 characters or less.

### Defaults

None.

### Usage

Issue ISQXOPT *target\_system\_ProcOps\_name* to display a full-screen panel that shows the values of the variables that define the operation of a specific target system, such as initial program load parameters and the responses to IPL messages. The following fields cannot be modified:

- Hardware mode
- Partition
- Target mode
- Operating system
- Hardware type
- Automatic response selection

Examples of this panel are shown in the following:

- Figure 137 on page 329 in basic-mode using an OCF-based processor
- Figure 138 on page 329 in LPAR mode using an OCF-based processor

```

ISQHOPT      SA OS/390 - Target System Options

      Modifiable options specified for target system      KEY2

Hardware mode: Basic mode      Target Mode:  ESA
Operating system:  MVS          Hardware Type: 9672
Target description:

      Image profile name
      Load profile name      LOADVMVS
      Reset profile name     390RESET

      Auto resp sel          Y

Response to IEA101A:

Response to IEA347A:

Required addresses:

PF1= Help PF3= End PF6= Roll Enter= Process changes

```

*Figure 137. Sample System Options Panel for an OCF-Based Processor in a Basic-Mode MVS Target System*

```

ISQHOPT1     SA OS/390 - Target System Options

      Modifiable options specified for target system      KEY2

Hardware mode: LPAR partition:  KEY21      Target mode:  ESA
Operating system:  MVS          Hardware type: 9672
Target description:

      Image profile name     KEY21
      Load profile name      DEFAULTLOAD
      Reset profile name     DEFAULT
      Secondary OCF name     KEY21

      Auto resp sel          Y

Response to IEA101A:

Response to IEA347A:

Required addresses:

PF1= Help PF3= End PF6= Roll Enter= Process changes

```

*Figure 138. Sample System Options Panel for an OCF-Based Processor in LPAR-Mode MVS Target System*

Issuing this command for a non-existent target system results in a panel for a Basic-mode system with a message that the specified target system does not exist. You can recover from this condition by simply typing in the name of the desired target system in the first field of the panel and pressing the Enter key. You can also type over the name of a valid target system on a valid panel and press the Enter key to change the display to that for a different target system.

Some variables can be changed by typing a new value over the old value and pressing Enter. When the variable is updated, the ISQXOPT panel is displayed again and another variable can be updated.

The information contained in the panel is retrieved, and the NetView View command presents the panel. The information you enter is checked and error

## ISQXOPT

messages are generated if the information is not valid. These error messages, which identify the field with the problem, are displayed on a separate panel that shows all error messages for all fields.

### Restrictions and Limitations

- You cannot issue the ISQXOPT command from within a program.
- You must issue the ISQXOPT command from an NCCF command line.

### Return Codes

Return codes are not applicable because you cannot issue this command from within a program.

---

## ISQXUNL

### Purpose

The ISQXUNL command cancels a console lock instituted by the ISQXLOC command.

### Syntax

```
▶▶—ISQXUNL—target_system_ProcOps_name—

|    |
|----|
| OC |
| SC |

▶▶
```

### Requirements

The requirements for this command to complete successfully are:

- Processor operations must be active.
- The addressed console must not be locked by another task.
- The *target\_system\_ProcOps\_name* syntax requires that the addressed target system be initialized.

### Parameters

*target\_system\_ProcOps\_name*

Is the name of the target system for the specified console.

OC

Specifies the active operator console (not valid for the coupling facility).

SC

Specifies the active system console (not valid for OCF-based processors).

### Defaults

None.

### Usage

The ISQXUNL command removes a console lock established by the ISQXLOC command (described on page 325). Any change in lock status is reflected in the status facility.

## Restrictions and Limitations

The ISQXUNL command is effective only when issued from the same task that issued ISQXLOC to establish the console lock.

## Return Codes

- |    |   |
|----|---|
| 0  | The ISQXUNL command completed successfully.   |
| 4  | The specified console was not locked.   |
| 8  | One of the following was specified: <ul style="list-style-type: none"><li>• Invalid syntax</li><li>• Invalid target system name</li><li>• Target system that is not initialized</li></ul> |
| 12 | The console is locked by another task.  |
| 32 | The processor operations environment does not exist; the ISQXUNL command was not processed.   |

For return codes greater than 12 that are not listed, a NetView CNMLOCK service problem occurred.

**ISQXUNL**

---

## Appendix A. Definitions for I/O Operations Commands

This appendix provides additional information for using I/O operations commands.

---

### ESCON/FICON Director Switch

The following is an example of a diagram used in this document to illustrate an ESCON director (or switch, as it is usually called).

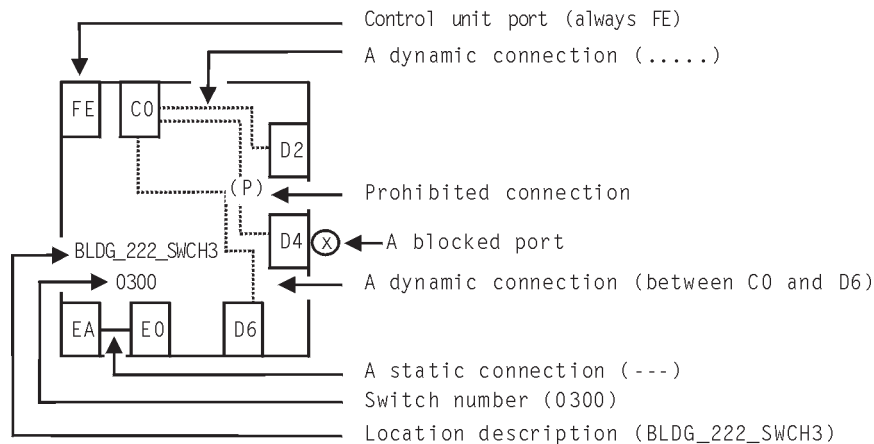

Figure 139. Sample of an ESCON Director Diagram.

---

### Switch Identifiers

A switch device number is a hexadecimal number containing up to four digits with any leading 0's (zeros) padded by I/O operations. The ADDRESS parameter of the IODEVICE macro in the I/O Definition File (IODF) specifies the switch device number.

In many I/O operations commands, a switch device number is required in the input to identify a switch that is allocated to the issuing I/O operations (primary host). The program also displays the switch device number on output.

Two related terms apply in this context:

- A *logical switch number* (LSN) is a 2-digit hexadecimal number that is assigned with the SWITCH parameter on the CHPID macro of the IOCP. I/O operations does not use an LSN as input, but it does display an LSN in the output of many of its Display and Query commands.
- A *switch identifier* (Switch ID) is identical with the switch's LSN. It is displayed by the I/O operations Workstation feature to be compatible with Hardware Configuration Definition (HCD), which also uses this term.

---

## Logical Switch Number (LSN)

An LSN is a 2-digit hexadecimal number that is assigned with the SWITCH parameter on the CHPID macro of the IOCP. I/O operations does not use an LSN as input, but it does display an LSN in the output of many of its display and query commands.

In many I/O operations commands, a switch device number is required in the input to identify a switch that is allocated to the issuing I/O operations (primary host). The program also displays the switch device number on output.

---

## Chain and Unchain a Switchable Path

A *chained path* is a path that passes statically (without dynamic connections) through one switch, which is called the *passthru switch* in the chain, and ends in a second, or *destination switch*. The two switches must be physically linked to each other. The ports in a chained path can be designated as the:

- A** Port to which the I/O interface of the channel is physically attached in a CH chain and the I/O interface of the control unit is attached in a CU chain.
- M** Port to which the A port is statically connected in the passthru switch.
- E** Port that ends the chain in the destination switch.
- D** Is the destination link address of the chain as defined in the I/O definition file (IODF) or I/O control data set (IOCDS). As you can see, port D is simultaneously port E in a CU chain, but not in a CH chain.

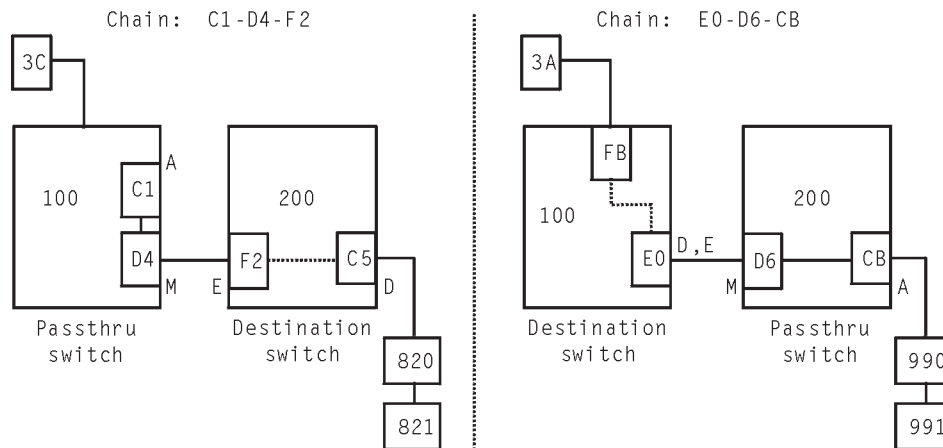

Figure 140. Examples of Chained Paths.

---

## Chaining a Path

1. You must define a chained path to I/O operations, and remove this definition when it is no longer needed.
2. The I/O operations used to define a chain or remove its definition must have dynamic access via CNC channel to the control unit port (CUP) on both switches in the chained path. (In Directors, the CUP address is X'FE'.)
3. I/O operations will *not* permit you to define, or remove the definition of, a chain if it can foresee that the chain command would fail these precursory checks:

- Remove the last path to the specified switch(es) in a Block, Connect, or Chain command
- Affect an unimplemented port
- Affect the control unit port (CUP) except to assign it a port name
- Allow a port to connect dynamically to itself
- Connect a port statically to itself or to more than one other port
- Connect a port that is not installed.
- Disconnect 2 ports that are not statically connected
- Chain a port that is already part of a different chain
- Chain ports so that they would create a loop

Chaining can affect the vary path requests that I/O operations issues. See “Processing a Vary Path Request” on page 349 for more information.

4. If you intend to define a chain that includes a parallel channel operating in block mode with a CV converter, such as an ESCON Converter Model 2 (9035) attached, use these guidelines for selecting noforce, nocheck, or force. The guidelines should help you decide whether to select NOForce, NOCheck, or Force as an option in a connectivity command that affects a CV converter.

*If the path is not chained and the foregoing requirements are met, you can enter a connectivity command with either the NOForce option or the NOCheck option.*

- If you specify NOForce, I/O operations will check for an operational CV converter in the path and process the command under the set of rules that apply.
  - a. If the CV converter is operational, I/O operations will:
    - 1) Fail a Block, Connect, Remove Switch, or Chain command that affects the port.
    - 2) Fail a Prohibit command that affects the path to the CV converter.
  - b. If the CV converter is not operational, I/O operations will:
    - 1) Issue a warning if an Unblock, Disconnect, RESTORE SWITCH, or Unchain command is entered that affects the port.
    - 2) Issue a warning if an Allow command is entered that affects the path to the CV converter.
- If you specify NOCheck, I/O operations will not check for a CV, and will process the command under the set of rules that apply.

*If the path is chained and the foregoing requirements are met, you must specify NOCheck or Force to unchain the path or to block any of the ports in the path.*

5. Make sure the channel I/O interface, the control unit I/O interface, and the link between the two switches are all attached properly. Ports A, M, E, and D in Figure 140 on page 334 are determined by these attachments. Also make sure the destination link address (port D) is defined properly in the IODF or IOCDS.
6. Remember that defining a chain and removing a defined chain can affect all the participants in the issuing I/O operations’ consensus vary-path processing.

## Two Scenarios for a CH Chain in a CNC Path

### Configuration:

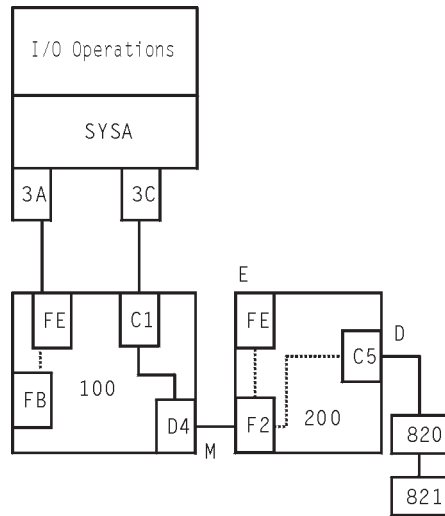

Figure 141. Chain - Scenario 1.

### Procedure:

```
VARY PATH(200,3C),OFFLINE,FORCE  
CF CHP(3C),OFFLINE,FORCE
```

```
CONNECT (C1) (D4) 100
```

```
CF CHP(3C),ONLINE  
VARY PATH(200,3C),ONLINE,FORCE
```

```
RESET S 200  
CHAIN (F2) 200 (D4) (C1) 100
```

To remove the definition, enter:

```
UNCHAIN (F2) 200 (D4) (C1) 100 VARY FORCE NOB
```

The Force option is required because the Unchain command removes the last path to the CUP on the destination switch.

If you do not configure CHPID 3C offline, enter:

```
BLOCK (C1) 100
```

### Configuration:

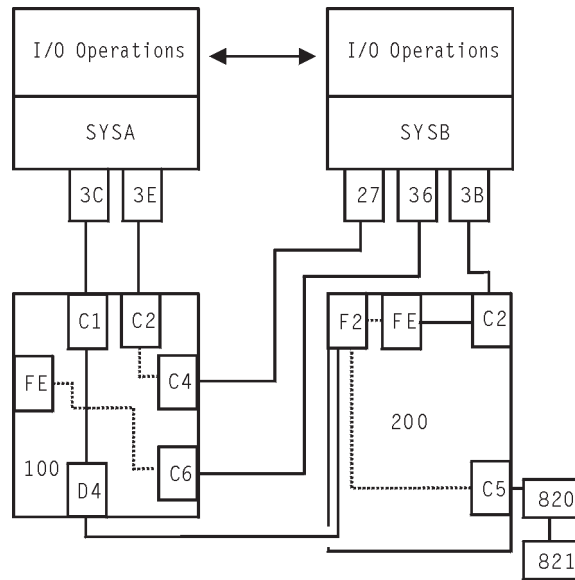

Figure 142. Chain - Scenario 2.

**Procedure:**

Enter from SYSA:

```
VARY PATH(200,3C),OFFLINE,FORCE
CF CHP(3C),OFFLINE,FORCE
```

Then, enter from SYSB:

```
CHAIN (F2) 200 (D4) (C1) 100
```

Finally, enter from SYSA:

```
CF CHP(3C),ONLINE
VARY PATH(200,3C),ONLINE,FORCE
RESET S 200
```

To remove the defintion, enter from SYSB:

```
UNCHAIN (F2) 200 (D4) (C1) 100 VARY FORCE NOB
```

The Force option is required because the Unchain command removes the last path to the CUP on the destination switch. If you do not configure CHPID 3C offline, enter:

```
BLOCK (C1) 100
```

---

## When a Command Fails

If you receive a message that a command failed, you first make sure I/O operations is running. Then, you should try to determine why the command failed, so you can correct it or report the problem to IBM.

- Make sure I/O operations is started. In MVS/ESA, to check if I/O operations has been started on the primary host, enter `display jobs, ESCON_Manager_procedure_name`. If I/O operations's procedure name appears in the list, I/O operations has been started.
- Determine why the command failed. If a command does not complete successfully, I/O operations issues an error message indicating a host did not

perform the command or a switch failed to perform the command, or both. Return codes and reason codes are issued when commands fail when using the API.

- Use the DISPLAY RESULTS command. This command displays information to help you quickly determine if the problem is host-related, switch-related, or both. A command can fail for one or more reasons, including switch-related or I/O operations-related problems.

The error message you receive might not provide you with sufficient information to determine the reasons why your command failed. If you need more information to understand the problem, you can display information about your configuration status to determine the specific reasons.

- Correct the command failure. Once you have determined the cause of a command failure and the present configuration status, you can begin to correct the problem using backout, reset, force, or other options.

---

## A “Partially-ESCON” Path

A partially-ESCON path is a path in which either the channel or the control unit in the I/O path is not an ESCON object.

To ensure system integrity when processing its switching commands, I/O operations relies on node descriptor (ND) or node element descriptor (NED) data from the ESCON objects involved. In a switchable partially-ESCON path, therefore, I/O operations cannot always ensure the same degree of system integrity that it can for “fully” ESCON paths.

---

## Channel Types

### *Types of channels:*

<b>CFR</b>	Coupling facility receiver
<b>CFS</b>	Coupling facility sender
<b>CFP</b>	Coupling facility peer channel
<b>CBR</b>	Integrated Cluster Bus receiver
<b>CBS</b>	Integrated Cluster Bus sender
<b>CBP</b>	Integrated Cluster Bus peer
<b>CNC_P</b>	A point-to-point ESCON channel
<b>CNS_S</b>	A switchable ESCON channel
<b>CTC_P</b>	A point-to-point channel-to-channel channel
<b>CTC_S</b>	A switchable channel-to-channel channel
<b>CVC_P</b>	A point-to-point converted channel
<b>CBY_P</b>	A point-to-point byte converter channel
<b>FC</b>	A FICON point-to-point channel
<b>FC_S</b>	A FICON switched channel
<b>FCV</b>	A FICON-to-ESCON bridge
<b>FC_?</b>	A FICON incomplete

**Note:** The last character of the DCM managed channels’ acronyms is ‘M’, for example, FCM or CNC~~S~~M.

<b>ICR</b>	Internal coupling receiver
<b>ICS</b>	Internal coupling sender
<b>ICP</b>	Internal coupling peer
<b>OSA</b>	An open systems adapter channel
<b>BLOCK</b>	A parallel channel operating in block mode
<b>BYTE</b>	A parallel channel operating in byte mode
<b>UNDEF</b>	A channel that is not defined

---

## Types Of Channels

I/O operations supports the following channel operational modes:

- ESCON Multiple Image Facility (EMIF) mode
- Logical Partition (LPAR) reconfigurable mode
- LPAR non-reconfigurable mode
- Basic mode

I/O operations can display, or return data on, all the channels known to it. For ESCON channels and for parallel channels operating in block mode, the program can be used to change the connectivity between these resources and others in their paths.

---

## ESCON Channels

I/O operations supports the following types of ESCON channels.

### An ESCON (CNC) Channel

A CNC channel path is used to transfer data between a host system image and an ESCON control unit. I/O operations can display data about a CNC channel path and change its connectivity.

### An ESCON Channel-to-Channel (CTC) Channel

When a CTC channel is defined to one system image, or host, it can communicate with a CNC channel defined on another host so that the two system images can communicate with each other for *intersystem communication*. The CTC channel views each CNC channel with which it communicates as a pseudo control unit, and vice versa.

### An ESCON Channel Operating in Converted (CVC) Mode

A CVC channel path transfers data in blocks and a CBY channel path transfers data by bytes. A CVC or CBY channel path is an ESCON channel that has been converted so that it can interface with an ESCON Converter Model 1 (9034), or equivalent, for communication with a parallel control unit.

A CVC or CBY path always resembles a point-to-point parallel path, regardless whether it passes through a switch or not. Thus, a switchable CVC or CBY path must pass through a switch as a static connection.

### A Parallel Channel

I/O operations can display information about parallel channels that operate in either byte (BY) or block (BL) mode. I/O operations can also change connectivity to a parallel channel operating in block mode.

### Coupling Facility Channels

I/O operations can display and return data about a Coupling Facility Receiver (CFR) channel and a Coupling Facility Sender (CFS) channel. However, I/O operations does not provide connectivity control for these types of channels.

### OSA Channels

The OSA channel provides an S/390 internal channel attachment to local area networks (LANs) that support Internet protocols such as fiber distributed data interface (FDDI), token ring, Ethernet, and high speed serial interface (HSSI).

---

## Making Connectivity Changes

You can use I/O operations as the single point of control for I/O connectivity changes in the active I/O configurations under its management.

In addition to an I/O operations base program running on a host, the host must be able to play a role with a group of hosts.

To develop safe procedures to protect your system's connectivity, you need to understand the functional characteristics of the dynamic switches that you control with SA OS/390. For example, the local console of IBM ESCON Directors has a setting that allows you to choose how the switch is restarted. If your operating procedures are to restart:

- From the same configuration that was most recently active on the ESCON Director, use the ESCON Director's ACTIVE=SAVED setting
- From a fixed IPL file, regardless of what was most recently active on the ESCON Director, you can set the ESCON Director to use that file

But note that your use of SA OS/390 varies accordingly. Changes that you make through SA OS/390 are only automatically restored after events like power failures if the ESCON Directors are set to ACTIVE=SAVED; if they are not, consider using SA OS/390 functions to update each ESCON Director's IPL file in accordance with your updates directly to the active configuration.

ESCON resources are self-defining. The relevant data is contained in a node descriptor (ND) of a port or an ESCON channel and in a node element descriptor (NED) of a switch device. I/O operations uses this data to ensure system integrity in its commands. It can also use the serial number of an ESCON resource to identify it.

When only the channel or the control unit is an ESCON unit, the non-ESCON unit can impose some limitations on I/O operations' ability to ensure coordination between the logical definition of the unit and its physical presence. (Unlike ESCON units, a non-ESCON unit is not self-defining.)

### NOForce|NOCheck|Force Option Set

With your choice among NOForce, NOCheck, and Force, you determine the stringency with which I/O operations forces the completion of a switching connectivity command under two conditions:

- If any of I/O operations's relevant vary path requests fail.
- If I/O operations checked and detected the presence of a protocol converter (CV) between the I/O interface of a parallel channel operating in block mode and the port on a dynamic switch. (NOForce is required for the REMOVE CHP and RESTORE CHP commands. NOCheck has an identical effect on these 2 commands.)

**NOForce:** (IBM-supplied default) instructs I/O operations to send a connectivity command to the specified switch(es) only if all of the following conditions have been met:

1. The results of consensus vary-path processing results are unanimously affirmative.
2. If a CV converter has been detected in the parallel channel path, completion of the command will not potentially interrupt dynamic data transfer through the specified switch(es).

3. If the command is disrupting a CVC channel, that CHPID has been configured offline.

If you specify NOForce, you must also specify Vary. NOForce requires the update level of authorization if I/O operations is secured by RACF or an equivalent program.

**NOCheck:** instructs I/O operations to send a connectivity command to the specified switch(es) only if all of the following conditions listed below have been met:

1. The results of consensus vary-path processing results are unanimously affirmative.
2. If the command is disrupting a CVC channel, that CHPID has been configured offline.

If you specify NOCheck, you must also specify Vary. NOCheck requires the update level of authorization if I/O operations is secured by RACF or an equivalent program. Commands entered at the system console automatically receive the highest, or control, authorization level.

**Force:** instructs I/O operations to send a connectivity command to the specified switch(es).

- If you specify Force, you must specify NOBackout.
- You cannot specify Force on a Remove Chp or Restore Chp command.
- Force requires the control level of authorization if I/O operations is secured by RACF or equivalent.

## Backout|Nobackout Option Set

By choosing between BACkout and NOBACkout, you can determine whether I/O operations will attempt to reverse, or to back out, its successful vary path offline requests if at least one relevant path could not be varied offline successfully.

- If the changes could be backed out, pathing status is returned to the state before the command was processed.
- If the changes are not backed out, pathing status may be mixed. (You can enter a DISPLAY RESULTS or DISPLAY VARY command to study the resulting status.)

**BACkout (IBM-supplied default):** instructs I/O operations to attempt to back out the vary path offline requests that were successful under a number of error conditions, such as: requests if at least one path affected by the command could not be varied offline successfully. Some of the conditions that would require I/O operations to attempt to back out vary path requests are:

- At least one relevant vary path offline request was not successful. For example, a voting I/O operations has returned a negative vote or the time limit for consensus processing was reached before all votes were returned.
- A switch affected by the connectivity command responded negatively.
- A channel could not be configured offline successfully with a Remove Chp command.

If you select BACkout, you cannot select Force.

**NOBACkout:** instructs I/O operations to not reverse any vary path requests that have been completed successfully during command processing or that are still in progress. You must specify NOBackout if you specify either NOVary or Force.

---

## Restore (Enable) a Switch

When the system operator completes a maintenance procedure and turns power to the unit on, you enter the RESTORE SWITCH command and specify the switch device number.

The I/O operations at which you issued the command (the issuing I/O operations) first allocates, or attaches the switch. Then it activates the configuration for the switch that the unit is programmed to select whenever power is turned on to it. Finally, it ensures all the paths in the selected configuration are varied online.

I/O operations informs you the command completed successfully. (If it completed unsuccessfully, you can enter the DISPLAY RESULTS command to obtain more data.)

---

## Switch Ports

CH	A CNC or CVC CHPID is defined for this port.
CU	A control unit is assigned to this port.
CHCH	More than one CNC or CVC CHPID is assigned to this port.
CHCU	Both a CHPID and a control unit are assigned to this port. CHCU is valid if the CHPID is a CTC channel. I/O operations does not report such a dual assignment as a configuration mismatch. However, CHCU is not a valid combination for any other type of CHPID. I/O operations does report such a dual assignment as a configuration mismatch.
CV	An ESCON Converter Model 2 (CV converter) is attached to this port. A CV converter (9035) converts ESCON protocol to a parallel CHPID operating in block or byte mode.
CVCH	A CV converter and an ESCON channel (CNC or CVC) are both assigned to this port. I/O operations reports such a dual assignment as a configuration mismatch.
CVCU	A CV converter and a control unit are assigned to this port. I/O operations reports such a dual assignment as a configuration mismatch.

---

## Logical Tokens

A *logical token* is an identifier created by hardware configuration description (HCD) for each I/O resource that is defined in an input output definition file (IODF). If two or more systems share an IODF, they will have the same logical token for the same I/O resource.

---

## Allow|Prohibit Mask of a Port

Each port is either allowed to have, or prohibited from having, a dynamic connection with another port on the same switch.

Collectively, these pairs of connectivity attributes form an *allow/prohibit mask*.

- A** Designates the ports for which a dynamic connection is allowed
- P** Designates the ports for which a dynamic connection is prohibited

An allow/prohibit mask is displayed by I/O operations as part of a matrix of a switch configuration. The program displays switch matrixes in its sample I/O operations ISPF (ESCM ISPF) dialog and at a graphic workstation. See examples in *System Automation for OS/390 User's Guide*.

---

## An ESCON-in-Converted-Mode (CVC) Path

An ESCON converted channel (CVC) is an ESCON channel that has been initialized to operate in converted mode to allow data to be transferred between its host and a parallel control unit.

A protocol converter such as the ESCON Converter Model 1, or equivalent, must be attached to the control unit. This type of converter is transparent to I/O operations.

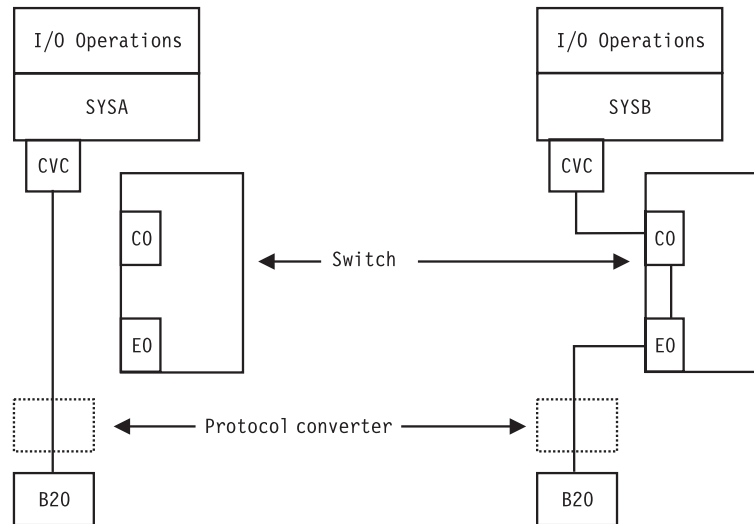

Figure 143. ESCON-in-Converted-Mode - Sample.

---

## Physical Tokens

A *physical token* is a 32-byte field that describes an I/O resource. Information in the physical token comes from either a node element descriptor (NED) or a node descriptor (ND). A NED is a 32-byte field that describes a node element of an I/O resource. A NED is associated with a physical control unit or device. A ND is a 32-byte field that describes a node interface of an I/O resource. A ND identifies a physical CHPID. When a physical token is input, the first 4 bytes are not used for comparison.

---

## Using Port Names as a Tool in Switching Commands

When you enter a switching command, you change the port attributes that control data transfer on the ports of the switch through which the path passes. The single switch or the pair of chained switches in a switchable path must be allocated to the issuing I/O operations (primary host) in the command. To facilitate the connectivity management of these switchable paths, I/O operations lets you assign, or write, a name of up to 24 characters to each addressable port on a switch.

A *port name* can consist of character strings, each of which identifies one of the resources in the path leading to or from the port. If you use the same character string in more than one port name, that character string effectively serves as a *generic name*.

To use a generic name instead of a full port name, you only need to mask off the irrelevant characters in the port name that precede or succeed or intervene between the generic character string you want to use. As a mask, you can place one asterisk (\*) in each port name.

---

## Switch Port Hardware Status on a Display Command

On the output of DISPLAY commands, I/O operations displays the hardware status for a port.

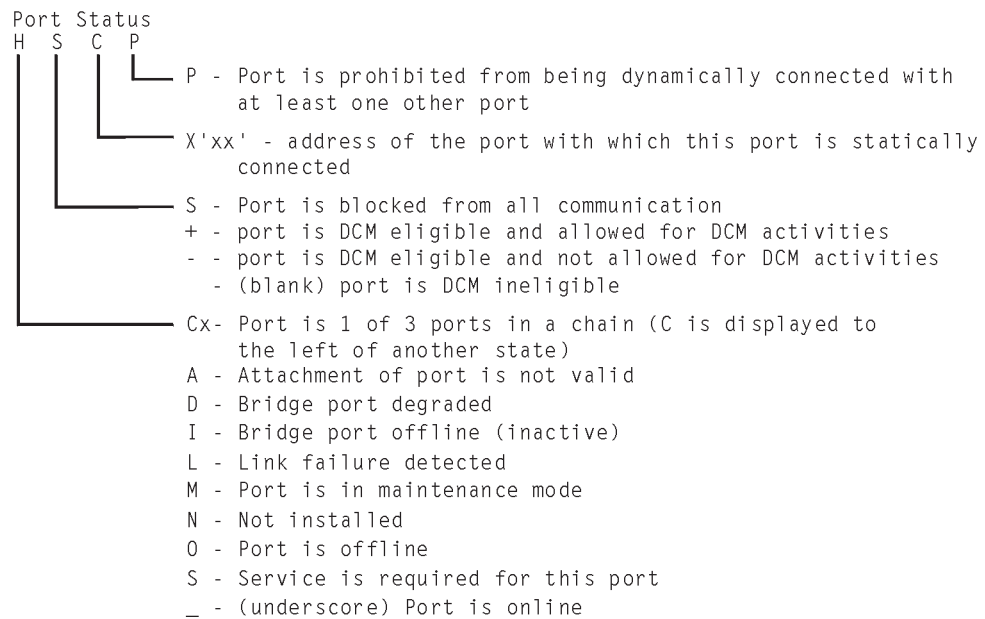

Figure 144. Switch Port Hardware Status Format.

For further information, refer to the program information block (PIB), which is described in the output block listed in "QUERY SWITCH" in *System Automation for OS/390 Programmer's Reference*.

---

## Remove (Quiesce) a Switch

When a service representative needs to have a switch quiesced and disabled in order to remove the unit, you can enter the I/O operations REMOVE SWITCH command to vary all the paths to and through the switch offline, including any paths to the switch (device) from the other hosts in its group and any chained paths leading to another switch. Optionally, you can specify the Disable option, so the service representative only has to turn power off to the unit. (You should *not* use the VARY DEV or the REMOVE DEV commands.)

I/O operations issues the appropriate vary path offline requests to the hosts. (It will not vary the path to the control unit port of the switch because it needs to communicate with the switch.)

The issuing I/O operations then sends the command to the switch (ESCD) and informs you that the command completed successfully. If the command completed unsuccessfully (for example, if a vary path request failed) you can analyze the data with the appropriate display command. If you cannot resolve the situation and the switch must be removed, you can rerun the REMOVE SWITCH command with the Force option. However, no paths will be varied offline.

## Port Switching Commands

You can change connections of ports on a switch with these commands:

- ALLOW
- BLOCK
- CONNECT
- DISCONNECT
- PROHIBIT
- UNBLOCK

The following examples help to illustrate the hierarchy of port attributes.

### PROHIBIT

**Example** `p (C0) (EA) 0100`

**Explanation** Prohibits data from being transferred dynamically between C0 and EA. Dynamic data transfer between C0 and D4 is not affected.

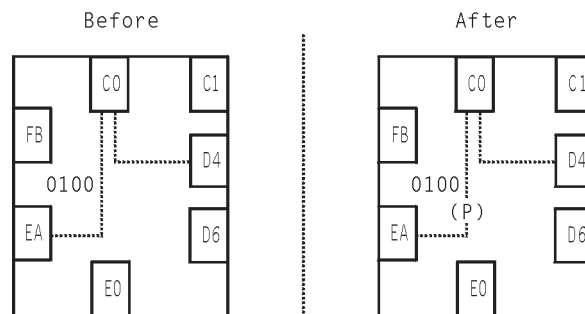

Figure 145. PROHIBIT Command Example

### CONNECT

**Example** `c (C0) (EA) 0100`

**Explanation** Statically connects C0 and EA for exclusive data transfer, despite the prohibition of a dynamic connection between these two ports. However, data cannot be transferred between C0 and D4.

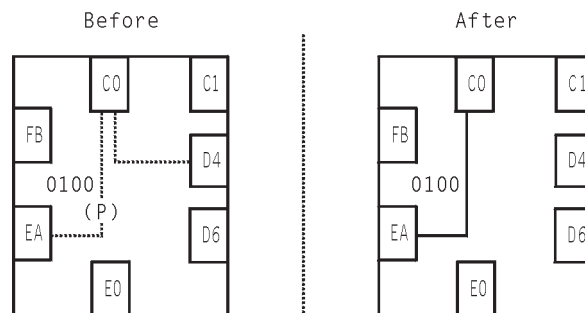

Figure 146. CONNECT Command Example

### BLOCK

**Example** `b (C0) 0100`

**Explanation** Blocks all data transfer through C0, regardless of its other connectivity. Data cannot be transferred between C0 and either D4 or EA.

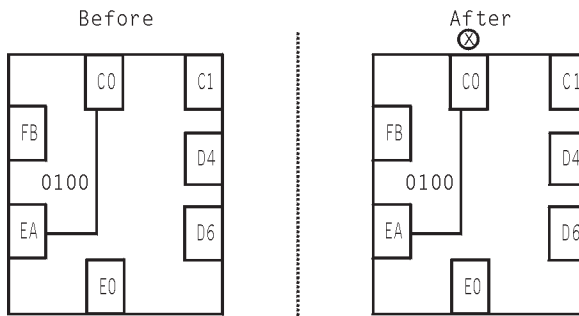

Figure 147. BLOCK Command Example

## UNBLOCK

**Example** u (C0) 0100

**Explanation** Unblocks C0, so that the static connection is again in effect.

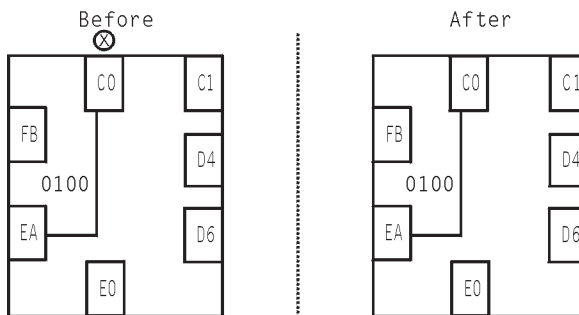

Figure 148. UNBLOCK Command Example

## DISCONNECT

**Example** n (C0) (EA) 0100

**Explanation** Removes the static connection between C0 and EA, but data cannot be transferred between these two ports because they are still prohibited from having a dynamic connection. However, data can now be transferred between C0 and D4.

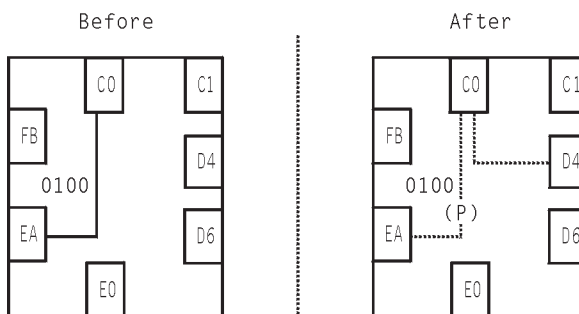

Figure 149. ALLOW Command Example

## ALLOW

**Example** a (C0) (EA) 0100

**Explanation** Allows data to be transferred dynamically between C0 and EA.

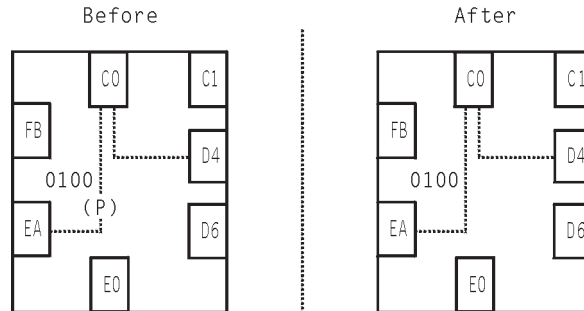

Figure 150. ALLOW Command Example

## A Parallel Channel in Block (BL) Mode

### Requirements for a Parallel Channel

- The parallel channel must be operating in block (BL) mode.
- The control unit in the path must be an ESCON-capable and “cooperating” control unit.
- The path can be switchable or nonswitchable.
- If the path is switchable, a protocol converter (CV object):
  - A protocol converter, such as the ESCON Model 2 (9035), or equivalent, must be attached between the channel I/O interface and the switch.
  - The switch must be allocated to the issuing I/O operations.

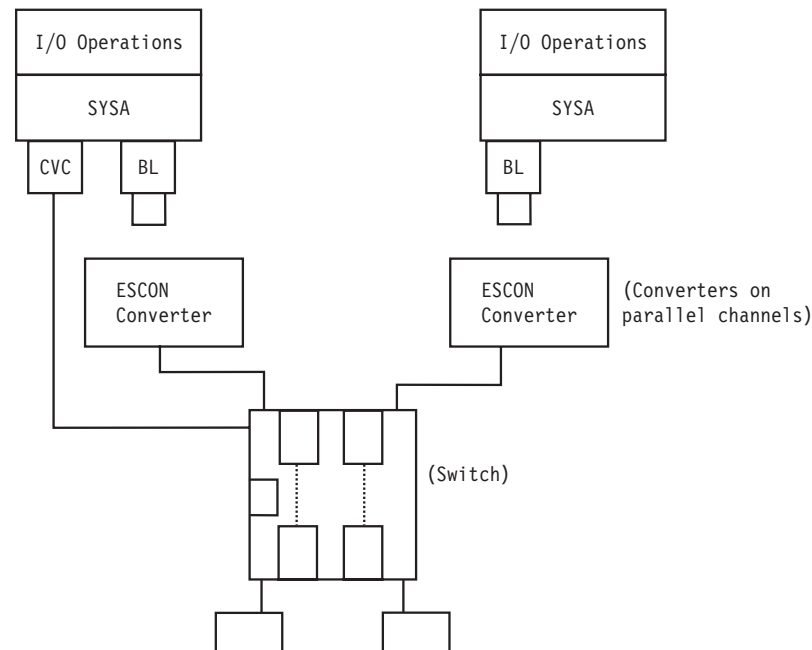

Figure 151. Parallel Channel in Block Mode - Sample.

---

## Switching Commands

The members of a group (domain) must be either:

- The issuing I/O operations, which is the base program (primary host) at which you enter, or to which you send, the command.
- An I/O operations base program that shares access to at least one dynamic switch in common with the issuing I/O operations.

If the switching command contains Vary (path) as an implicit or explicit option, the issuing I/O operations broadcasts the request to the other base programs. Each base program issues the appropriate vary path requests to its own system (host) image. The results must be known by the issuing I/O operations within a preset time interval. After the results are in or when the time interval expires, the issuing I/O operations determines whether it and the voters have reached the consensus that all the vary path requests completed successfully. If so, the issuing I/O operations proceeds with command processing.

### Notes:

1. Because an issuing I/O operations is also called the primary host, or the primary I/O operations host, a voter is also called a secondary host, or a secondary I/O operations host.
2. A voter is *active* if it has not been excluded, or reset, from voting, by the Reset Host command.
3. A voter is *inactive* if it has been excluded by a Reset Host Off command.
4. A voter is *purged* if it has been excluded by a Reset Host Purge command. To I/O operations, a purged voter simply does not exist.
5. The preset time interval is either the IBM-supplied default of 60 seconds or a time interval set with the Reset Timeout command.

---

## A Sample Way to Modify a Switch Matrix

When a switch matrix is displayed, you can make changes on it; you do not have to enter commands on the command line. In fact, you can invoke the DISPLAY RESULTS command, which is described more fully on page 231. Refer to *System Automation for OS/390 User's Guide* for information about a switch matrix.

---

## Port Addresses

A port address is a two-digit hexadecimal number that identifies an addressable port on a switch.

---

## Switch Unique Identifier

You can use the DISPLAY SWITCH command to display the 26-character switch unique identifier. The format is:

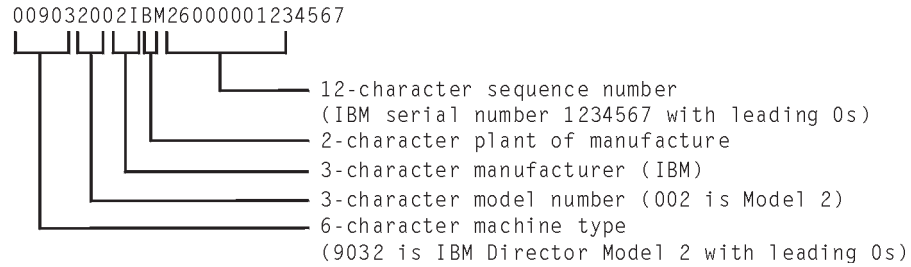

Figure 152. Switch Unique Identifier Format.

## Processing a Vary Path Request

When you have chosen Vary as a connectivity option, the issuing I/O operations and its active voting constituency issue the appropriate vary path requests to their host operating system images. The host images comply with the appropriate VARY PATH ON/OFF commands.

### General Rules

I/O operations adheres to the following rules. When the vary path processing has been completed successfully, these rules are of only moderate interest to you. However, if one or more requests failed, you need to know these rules to help you analyze the cause of the failure.

- If I/O operations knows that the appropriate vary path requests have already been performed, it takes no action. For example, if a port is blocked, all paths are varied offline. If a Prohibit command is then entered for the blocked port, no further action is taken for that port.
- If two port attributes are to be changed with the same Writeport or Writeswch command, the hierarchy remains in effect. (See “Port Switching Commands” on page 345 for more information on port hierarchy.) For example, if you specify that a port be both blocked and disconnected with the same command, I/O operations will perform the vary path processing needed to block that port and disconnect it.
- To keep I/O path disruption to a minimum should a command fail, I/O operations varies:
  - Offline *before* it sends a command to a switch.
  - Online *after* it sends a command to a switch.

*A chained path adds another level of complexity to these rules.* Paths through all three ports involved in a chain might be affected by the same connectivity command. For example, the command might affect the middle port’s connectivity. However, vary path processing might be required for the port on the destination switch that ends the chain.

If a CV converter is in the chained path, you must specify NOCheck or Force as a connectivity option if you want to block any of the 3 ports involved or you want to unchain the chain. (If you specify NOForce, the command will fail.)

---

## VTAM Application Name

For communication among I/O operations base programs, I/O operations uses VTAM. To participate in this intersystem communication, therefore, a base program must be defined as an application according to the rules for VTAM definitions. For information on these definitions, refer to the I/O operations program directory for the host operating system on which you intend to use the application.

VTAM returns the VTAM application name to a base program when it is started, thus identifying that base program. The base program uses its *VTAM application name* as its *host name* to register itself to the members of its group when it allocates each dynamic switch.

*To get a list of the VTAM (application), or host, names* known to an issuing I/O operations (primary host), enter the Display Host command as D H \* or view the pages of that host's online notebook.

*To remove or restore a base program (host)* from participating in consensus vary-path processing, use the Reset Host command. (This command has three options: Off, Purge, and On.)

## Appendix B. General Considerations for I/O Operations Commands

Table 6 lists the I/O operations commands in alphabetical order with a cross-reference that shows where they can be used and the access authorization levels they require.

**Notes:**

1. Access authorization is not required, although it is very advisable.
2. Authorization level is not checked for I/O operations commands that are entered at the system console. The control level of authorization is assumed.
3. RACF profiles are defined with a class of FACILITY.
4. The cross-references in the following table are described below:
  - C** Control authorization level is required.
  - G** Function is generated implicitly, but RACF, or equivalent, authorization is required if I/O operations is used in conjunction with a security program.
  - I** Command function is generated implicitly as part of a G function. RACF, or equivalent, authorization does not apply.
  - R** Read authorization level is required.
  - U** Update authorization level is required.
  - UC** Update authorization level is required for the NOForce|NOCheck options. Control level is required for the Force option.
  - Y** Command must be entered explicitly. RACF authorization is required.
  - The command is not available, neither explicitly nor implicitly.

Table 6. Commands, Their Availability and Access Authorization Levels

RACF Profile Name	RACF Authorization Level							Command Name
	Application Program Interface (API)							
	Switch Configuration Matrix (SA OS/390 Workstation and I/O Operations ISPF Dialog)							
	I/O Operations ISPF Dialog Command							
					Graphic View Window	System Console		
Not Applicable	-	-	-	-	-	Y	System Commands to Start/Stop	
IHV.ALLOW	UC	Y	I	Y	Y	Y	ALLOW	
IHV.BLOCK	UC	Y	I	Y	Y	Y	BLOCK	
IHV.CHAIN	UC	Y	-	Y	-	Y	CHAIN	
IHV.CONNECT	UC	Y	I	Y	Y	Y	CONNECT	
IHV.DELETE.FILE	C	Y	G	-	G	-		
IHV.DISCONNECT	UC	Y	I	Y	Y	Y	DISCONNECT	
IHV.CHP	R	Y	-	Y	I	Y	DISPLAY CHP	
IHV.DEV	R	Y	-	Y	I	Y	DISPLAY DEVICE	

Table 6. Commands, Their Availability and Access Authorization Levels (continued)

RACF Profile Name	RACF Authorization Level							Command Name
		Application Program Interface (API)						
		Switch Configuration Matrix (SA OS/390 Workstation and I/O Operations ISPF Dialog)						
		I/O Operations ISPF Dialog Command						
		Graphic View Window			System Console			
IHV.HOST	R	Y	-	Y	I	Y	DISPLAY HOST	
IHV.NAME	R	Y	I	Y	I	Y	DISPLAY NAME	
IHV.PORT	R	Y	I	Y	I	Y	DISPLAY PORT	
IHV.RESULTS	R	Y	-	Y	-	Y	DISPLAY RESULTS	
IHV.SWITCH	R	Y	I	Y	I	Y	DISPLAY SWITCH	
IHV.TIMEOUT	R	Y	-	Y	-	Y	DISPLAY TIMEOUT	
IHV.VARY	R	Y	-	Y	-	Y	DISPLAY VARY	
IHV.GETLOCK	C	Y	-	Y	G	Y	"GETLOCK I/O operations"	
IHV.LOGREC	C	Y	-	Y	-	Y	"LOGREC I/O operations"	
IHV.PROHIBIT	UC	Y	I	Y	Y	Y	"PROHIBIT I/O operations"	
IHV.QUERY.ENTITY	R	Y	-	-	G	-	"QUERY ENTITY HOST I/O operations"	
IHV.QUERY.FILE	R	Y	G	-	G	-	"QUERY FILE I/O operations"	
IHV.QUERY.INTERFACE	R	Y	-	-	G	-	"QUERY INTERFACE CNTLUNIT"	
IHV.QUERY.RELATION	R	Y	-	-	G	-	"QUERY RELATION HOST"	
IHV.QUERY.SWITCH	R	Y	G	-	G	-	"QUERY SWITCH I/O operations"	
IHV.REMOVE.CHP	UC	Y	-	Y	Y	Y	"REMOVE CHP I/O operations"	
IHV.REMOVE.DEV	UC	Y	-	Y	G	-	"REMOVE and RESTORE DEV" .br "REMOVE and RESTORE DEV (API)"	
IHV.REMOVE.SWITCH	UC	Y	-	Y	-	Y	"REMOVE SWITCH I/O operations"	
IHV.RESET.HOST	C	Y	-	Y	Y	Y	"RESET HOST I/O operations"	
IHV.RESET.SWITCH	C	Y	-	Y	Y	Y	"RESET SWITCH I/O operations"	
IHV.RESET.TIMEOUT	C	Y	-	Y	-	Y	"RESET TIMEOUT I/O operations"	
IHV.RESTORE.CHP	U	Y	-	Y	Y	Y	"RESTORE CHP I/O operations"	
IHV.RESTORE.DEV	UC	Y	-	Y	G	-	"REMOVE and RESTORE DEV" .br "REMOVE and RESTORE DEV (API)"	
IHV.RESTORE.SWITCH	UC	Y	-	Y	-	Y	"RESTORE SWITCH I/O operations"	
IHV.SYNC.SWITCH	C	Y	-	Y	Y	Y	"SYNCH SWITCH I/O operations"	
IHV.UNBLOCK	UC	Y	I	Y	Y	Y	"UNBLOCK I/O operations"	
IHV.UNCHAIN	UC	Y	-	Y	-	Y	"UNCHAIN I/O operations"	
IHV.UNLOCK	UC	Y	-	Y	G	Y	"UNLOCK I/O operations"	
IHV.WRITE	C	Y	I	Y	G	Y	"WRITE I/O operations"	
IHV.WRITEFILE	C	Y	G	-	G	-	"WRITEFILE I/O operations"	
IHV.WRITEPORT	UC	Y	-	-	-	-	"WRITEPORT I/O operations"	
IHV.WRITESWCH	UC	Y	G	-	G	-	"WRITESWCH I/O operations"	

---

## General Information and Tips for Using Multisystem Commands

1. If you are entering an array or table, it must be fully contained in a single variable, by itself, and with no leading blanks (trailing blanks are acceptable because they will be ignored). Without this restriction, you could enter an array or table that has bytes that look like blanks, will be parsed as blanks, and will make the results unpredictable.
2. Release 3 array elements are checked for validity because they are all character data. Tables are not checked for validity because numeric data is assumed to be hexadecimal (and so can never be invalid). Tables are not subject to translation and only the RNUMs are taken from the table.
3. For Release 3, host applnames will be checked for validity. Valid names follow MVS member name rules.

**Note:** This only applies to Query commands.

Info like `xxxx(n` and `xxxx(n)` is interpreted as Release 2 only when "xxxx" is not a defined object type  
For Release 3, `xxxx` can be `HOST`, `RNUM`, `PTOK`, `LTOK`, and so on.

"`HOST()`" and "`XSYS()`" are interpreted as an error (no name is included between the beginning and ending parenthesis)

4. Release 2 EXECs and programs should function with Release 3 as long as the EXEC or program is using the returned `HDR_SIZE` and `ROW_SIZE` (or `Format_id`) to parse through the output structure, with the following exceptions:
  - a. A summary ROW for each host will be returned as the FIRST row for each responder host that is returning data (does not have a command start failure). This ROW is marked by `RCODE='5100FFFF'x` and contains (currently) status bits.
  - b. Query Interface Switch/CntlUnit commands change their output structures to move the switch/control unit description into every row instead of having it reside in the header; with multihost responses, there is no way to resolve which switch description would have stayed in the command header (each host could have a different description of the switch/control unit).
5. For Release 3 table input, the responder must be the same as the host targeted to return the response.
6. For Query Interface commands (only), when the interface is not found on the entity1 switch/cu, row `rcode='5100 0016'x`.
7. Query Interface Switch returns no rows when the switch being queried is closed. Also, Query Interface CntlUnit returns no rows when the PID for the control unit is not valid.
8. The lock owner field in the QEH command is only valid when the responder host is the same as the object/entity host. For example, if you issue a Query Entity Host Value `HOST(*) SCOPE Value HOST(*)` command, the QEH that is returned will contain #hosts x #hosts ROWs (because each host will return all the hosts it knows about) but the only valid lockowner fields will be where:  
`QEH.ROW(i).RESPONDER.APPLNAME = QEH.ROW(i).APPL_NAME.`

---

## General Considerations for Using the Query Entity|Interface|Relations Commands

1. **Input for Query Entity and Query Interface commands** A Query Relation table can be input for all Query Entity and Query Interface Switch commands.
2. **Data returned** For the Query Entity, Query Interface, and Query Relation commands, use the self-description data (header size, row size, format ID) that is returned with each output structure to parse the data.
3. **Duplicate rows** No duplicate rows will be returned unless an array or table is used as the second entity asking for duplicate information to be returned. This implies that unless complete pathing (host-to-device or CHPID-to-device) is specified in your command, you could be getting summary data back.

For example, assume your configuration contains CHPIDs 10, 11, and 12, each with a path to control unit 100. Additionally, control unit 100 has devices 100–107 on it.

A **Query Relation CU 100 Chp Value \*** (tell me all CHPIDs that access device 100) would return 3 data QRO.ROWS to describe the 3 paths (CHPID 10 to device 100, CHPID 11 to device 100 and CHPID 12 to device 100). These are examples of complete path definitions.

If you issue **Query Relation CU 100 Dev Value 100** (tell me whether device 100 is defined to be on CU 100), only 1 data QRO.ROW is returned (not 3) indicating that there is a logical relationship between the 2 entities but not complete details (paths) on the relation because the command did not ask for complete pathing.

4. **Multiple rows**

A single array entry could generate more than 1 row returned. For example, the relation between a device and a host will return as many rows as there are CHPIDs that access the given device.
5. **Rules for columns of data** Although the same structure is returned for every Query Relation command, different columns of data are returned for the different variations of the commands. The following rules apply:
  - a. STATBITS are set for every command.
  - b. The columns between HOST and DEVICE are command-dependent; that is, Query Relation Host-Host commands return only the HOST column, Query Relation Host-Chp commands return both the HOST and CHPID columns, Query Relation Host-Switch commands return HOST, CHPID, PORTIN, SWDEVN, and LSN columns (note that STATBITS are required to validate PORTIN and SWDEVN as these might or might not be known), and so on.
  - c. Like entities are not allowed except host-to-host relations, which indicate VTAM relations, and switch-to-switch relations, which indicate chaining relations.
  - d. Data for a secondary host (voting I/O operations) will be marked INCOMPLETE because data bases are not shared among participating I/O operations.
  - e. When no host is named in a command, the primary host (issuing I/O operations) is assumed.
6. **Sorting of output** Sorting is done only if you specify Value or Range as options for the format of the output. If you specify Array or Table, I/O operations returns data in the same order as the input array or table.
7. **Chpid filtering of pathing information is handled as follows:**
  - a. If a channel is reserved to a partition that is not the one you are running on, the channel will appear as not defined.

- b. I/O operations only returns paths where the Chpid is not reserved to another partition.

8. **Reason codes that are related to Return codes**

In addition to the return codes (RCs) and reason codes that are also returned for the Display and the Query Switch commands, such as CHSC data refreshed, lock indicators, switch configurations, and so on, the following combinations are unique to the Query commands:

- With RC = 4, a reason code of X'51001004' indicates that some host has at least one summary row bit set.
- For RC = 8, a Getmain failure occurred.
- With RC = 20, a reason code of X'51xyyyy' indicates that I/O operations has detected an internal error. You should report this problem to IBM.

9. **Overflow conditions** In the Query Entity, Query Interface, and Query Relation commands the header and summary rows of the output contains a bit to indicate that an overflow condition was detected in the response buffer.

• **If you entered a Query Entity or Query Interface command:**

Enter another (similar) command to retrieve the subset of data that has not been returned.

For example, if the command that overflowed was **Query Entity Dev Value \*** and the last device entry returned to you is (device number) 743, the next command you should issue is **Query Entity Dev Range 744-\***.

If you are using an array (or table) as input for a command, you should continue to use the array/table form of command but adjust your array/table input to begin at the (*output\_num\_rows+1*) element in your next array command.

• **If you entered a Query Relation command:**

When translating your original command to a new format due to an overflow return/reason code, you might need to begin your new command with the last value returned for the second entity (not the one after the last value returned) or some pathing information could be lost.

For example, assume you have the following partial configuration:

Host = *IHVAPPL1* CHPIDs = 1,2,3,4,5 CntlUnits = 100 (accessed by CHPIDs 1,2,3), 200 (accessed by CHPIDs 3,4,5) Devices = 100-10F (off CU 100), 200-20F (off CU 200)

Assume (for the purposes of this example only) that 7 is the maximum number of rows that can be returned with any Query Relation command (in reality this number is more on the order of 2700).

You issue **Query Relation Host IHVAPPL1 Dev Value \*** to request all the IOCDS paths defined for this host.

I/O operations returns 7 rows describing paths (1,100), (2,100), (3,100), (1,101), (2,101), (3,101) and (1,102) with RC and RSN indicating overflow and the MORE\_DATA bit in the output table set.

Because you only received 1 of 3 rows (paths) back for device 102, you must now use the command **Query Relation Host IHVAPPL1 Dev Range 102-\*** to retrieve the pathing information for this host.

10. **Chaining** Chaining is indicated in an AEAM for a port by virtue of the log\_class=switch (port) and the LOGICAL bit being set.

If the path is chained, the switch that appears in the row for a path is either:

- a. The dynamic switch in the chain, or (if there is no dynamic switch)

- b. The switch that the CHPID for the path is defined (in IOCDS) to be on (by the SWITCH= parameter).
11. **“Physical” rules with respect to the EAM/AEAM are:**
- a. EAM.LOGICAL or AEAM.LOGICAL = 1 (binary) means the entity is defined in the IOCDS. Additionally, Chain commands are considered logical definition data so they are also included in “logical” data.
  - b. PHYSICAL (current, history and not valid) means “according to link level data” (node element descriptors [NEDs] or node descriptors [NDs]).
  - c. Physical OTHERS bits (and NDs) are set when the interface for an entity being queried does not have the same validity as the entity itself (as represented in the physical ID). OTHER\_NDs are validated by AEAM bits (OTHERS bits are never set in EAMs). The OTHER\_ND that is returned contains a ND for the attached entity that is causing the PID to be “more valid” than the interface being queried.
  - d. Logical OTHER bit (and value) is set when the interface for an entity being queried does not have an IOCDS path defined to it on the interface being queried (that is, a physical-only path to the entity) but the entity is defined in the IOCDS and is accessible by other paths. The OTHER\_LOG field will be set to the smallest logical value for the entity (for example, if control units 100 and 200 are hung off a port in a physical-only relationship but are defined to have other (IOCDS) paths elsewhere, the LOG\_OTHER bit would be set for the (QIS) port’s AEAM and the OTHER\_LOG would contain 100).
12. **P\_AMB, when on, means at least one of the following:**
- a. All the (IOCP/IODF) defined interfaces to the control unit do not have the same WWID (only valid NDs are checked).
  - b. For switches only: Even if all the WWIDs in the interfaces for the CNTL match, if the CNTLPID.WWID is different from the SWITPID.WWID (which is obtained from the NED), then the CNTLPID is marked P\_AMB and remains REFLECTED.
  - c. For CHPIDs only: When the attached ND’s WWID is not the same as the PID.WWID of the switch it’s supposed to be attached to.

---

## Glossary

This glossary includes terms and definitions from:

- The *IBM Dictionary of Computing* New York: McGraw-Hill, 1994.
- The *American National Standard Dictionary for Information Systems*, ANSI X3.172-1990, copyright 1990 by the American National Standards Institute (ANSI). Copies can be purchased from the American National Standards Institute, 1430 Broadway, New York, New York 10018. Definitions are identified by the symbol (A) after the definition.
- The *Information Technology Vocabulary* developed by Subcommittee 1, Joint Technical Committee 1, of the International Organization for Standardization and the International Electrotechnical Commission (ISO/IEC JTC1/SC1). Definitions of published parts of this vocabulary are identified by the symbol (I) after the definition; definitions taken from draft international standards, committee drafts, and working papers being developed by ISO/IEC JTC1/SC1 are identified by the symbol (T) after the definition, indicating that final agreement has not yet been reached among the participating National Bodies of SC1.

The following cross-references are used in this glossary:

**Contrast with.** This refers to a term that has an opposed or substantively different meaning.

**Deprecated term for.** This indicates that the term should not be used. It refers to a preferred term, which is defined in its proper place in the glossary.

**See.** This refers the reader to multiple-word terms in which this term appears.

**See also.** This refers the reader to terms that have a related, but not synonymous, meaning.

**Synonym for.** This indicates that the term has the same meaning as a preferred term, which is defined in the glossary.

**Synonymous with.** This is a backward reference from a defined term to all other terms that have the same meaning.

## A

**ACF.** Automation control file.

**ACF/NCP.** Advanced Communications Function for the Network Control Program. See *Advanced Communications Function* and *Network Control Program*.

**ACF/VTAM.** Advanced Communications Function for the Virtual Telecommunications Access Method. Synonym for *VTAM*. See *Advanced Communications Function* and *Virtual Telecommunications Access Method*.

**ACO.** Automated console operations.

**active monitoring.** In System Automation for OS/390, the acquiring of resource status information by soliciting such information at regular, user-defined intervals. See also *passive monitoring*.

**adapter.** Hardware card that enables a device, such as a workstation, to communicate with another device, such as a monitor, a printer, or some other I/O device.

**Address Space Workflow.** In RMF, a measure of how a job uses system resources and the speed at which the job moves through the system. A low workflow indicates that a job has few of the resources it needs and is contending with other jobs for system resources. A high workflow indicates that a job has all the resources it needs to execute.

**adjacent hosts.** Systems connected in a peer relationship using adjacent NetView sessions for purposes of monitoring and control.

**adjacent NetView.** In System Automation for OS/390, the system defined as the communication path between two System Automation for OS/390 systems that do not have a direct link. An adjacent NetView is used for message forwarding and as a communication link between two System Automation for OS/390 systems. For example, the adjacent NetView is used when sending responses from a focal point to a remote system.

**Advanced Communications Function (ACF).** A group of IBM licensed programs (principally VTAM, TCAM, NCP, and SSP) that use the concepts of Systems Network Architecture (SNA), including distribution of function and resource sharing.

**advanced program-to-program communication (APPC).** A set of inter-program communication services that support cooperative transaction processing in a Systems Network Architecture (SNA) network. APPC is the implementation, on a given system, of SNA's logical unit type 6.2.

**alert.** (1) In SNA, a record sent to a system problem management focal point or to a collection point to communicate the existence of an alert condition. (2) In

NetView, a high-priority event that warrants immediate attention. A database record is generated for certain event types that are defined by user-constructed filters.

**alert condition.** A problem or impending problem for which some or all of the process of problem determination, diagnosis, and resolution is expected to require action at a control point.

**alert focal—point system.** See entry for NPDA focal-point system under *focal—point system*.

**alert threshold.** An application or volume service value that determines the level at which System Automation for OS/390 changes the associated icon in the graphic interface to the alert color. System Automation for OS/390 may also issue an alert. See *warning threshold*.

**APF.** Authorized program facility.

**API.** Application programming interface.

**APPC.** Advanced program-to-program communications.

**application.** An OS/390 subsystem or job monitored by System Automation for OS/390.

**Application entry.** A construct, created with the customization dialogs, used to represent and contain policy for an application.

**application group.** A named set of applications. An application group is part of a System Automation for OS/390 enterprise definition and is used for monitoring purposes.

**ApplicationGroup entry.** A construct, created with the customization dialogs, used to represent and contain policy for an application group.

**application program.** (1) A program written for or by a user that applies to the user's work, such as a program that does inventory or payroll. (2) A program used to connect and communicate with stations in a network, enabling users to perform application-oriented activities.

**ARM.** Automatic restart management.

**ASCB.** Address space control block.

**ASCB status.** An application status derived by System Automation for OS/390 running a routine (the ASCB checker) which searches the OS/390 address space control blocks (ASCBs) for address spaces with a particular job name. The job name used by the ASCB checker is the job name defined in the customization dialog for the application.

**ASCII (American National Standard Code for Information Interchange).** The standard code, using a coded character set consisting of 7-bit coded characters

(8-bits including parity check), for information interchange among data processing systems, data communication systems, and associated equipment. The ASCII set consists of control characters and graphic characters. (A)

**ASF.** Automation status file.

**assist mode facility.** A System Automation for OS/390 facility that uses SDF and enables interaction with automation before System Automation for OS/390 takes an automation action. SDF prompts the operator with a suggested action, then provides options for using that action, modifying and using the action, or canceling the action. Also called assist mode, it is enabled using the customization dialogs, or dynamically.

**authorized program facility (APF).** A facility that permits identification of programs that are authorized to use restricted functions.

**automated function.** System Automation for OS/390 automated functions are automation operators, NetView autotasks that are assigned to perform specific automation functions. However, System Automation for OS/390 defines its own synonyms, or *automated function names*, for the NetView autotasks, and these function names are referred to in the sample policy databases provided by System Automation for OS/390. For example, the automation operator AUTBASE corresponds to the System Automation for OS/390 automated function BASEOPER.

**automated console operations (ACO).** The concept (versus a product) of using computers to perform a large subset of tasks ordinarily performed by operators, or assisting operators in performing these tasks.

**automatic restart management.** An OS/390 recovery function that improves the availability of specified subsystems and applications by automatically restarting them under certain circumstances. Automatic restart management is a function of the Cross-System Coupling Facility (XCF) component of OS/390.

**automatic restart management element name.** In MVS 5.2 or later, OS/390 automatic restart management requires the specification of a unique sixteen character name for each address space which registers with it. All automatic restart management policy is defined in terms of the element name, including System Automation for OS/390's interface with it.

**automation.** The automatic initiation of actions in response to detected conditions or events. System Automation for OS/390 provides automation for OS/390 applications, OS/390 components, and remote systems that run OS/390. System Automation for OS/390 also provides tools that can be used to develop additional automation.

**automation control file (ACF).** In System Automation for OS/390, a file that contains system-level automation policy information. There is one master automation control file for each NetView system on which System Automation for OS/390 is installed. Additional policy information and all resource status information is contained in the *OIB* (operational information base). The System Automation for OS/390 customization dialogs must be used to build the automation control files. They must not be edited manually.

**automation flags.** In System Automation for OS/390, the automation policy settings that determine the operator functions that are automated for a resource and the times during which automation is active. When System Automation for OS/390 is running, automation is controlled by automation flag policy settings and override settings (if any) entered by the operator. Automation flags are set using the customization dialogs.

**Automation NetView.** In System Automation for OS/390 the NetView that performs routine operator tasks with command procedures or uses other ways of automating system and network management, issuing automatic responses to messages and management services units.

**automation operator.** Automation operators are NetView autotasks that are assigned to perform specific automation functions. See also *automated functions*.

**automation policy.** The policy information governing automation for individual systems. This includes automation for applications, OS/390 subsystems, OS/390 data sets, and OS/390 components.

**automation policy settings.** The automation policy information contained in the automation control file. This information is entered using the customization dialogs. You can display or modify these settings using the customization dialogs.

**automation procedure.** A sequence of commands, packaged as a NetView command list or a command processor written in a high-level language. An automation procedure performs automation functions and runs under NetView.

**automation status file.** In System Automation for OS/390, a file containing status information for each automated subsystem, component or data set. This information is used by System Automation for OS/390 automation when taking action or when determining what action to take. In Release 2 and above of AOC/MVS, status information is also maintained in the operational information base.

**automation table.** See *NetView automation table*.

**autotask.** A NetView automation task that receives messages and processes automation procedures. There are no logged-on users associated with autotasks. Each

autotask is an operating system task and runs concurrently with other NetView tasks. An autotask could be set up to handle JES2 messages that schedule automation procedures, and an automation statement could route such messages to the autotasks. Similar to *operator station task*. System Automation for OS/390 message monitor tasks and target control tasks are autotasks. Also called *automation operator*.

**available.** In VTAM programs, pertaining to a logical unit that is active, connected, enabled, and not at its session limit.

## B

**basic mode.** A central processor mode that does not use logical partitioning. Contrast with *logically partitioned (LPAR) mode*.

**BCP Internal Interface.** Processor function of CMOS-390, zSeries processor families. It allows the communication between basic control programs such as z/OS and the processor support element in order to exchange information or to perform processor control functions. Programs using this function can perform hardware operations such as ACTIVATE or SYSTEM RESET.

**beaconing.** The repeated transmission of a frame or messages (beacon) by a console or workstation upon detection of a line break or outage.

**BookManager.** An IBM product that lets users view softcopy documents on their workstations.

## C

**central processor (CP).** The part of the computer that contains the sequencing and processing facilities for instruction execution, initial program load (IPL), and other machine operations.

**central processor complex (CPC).** A physical collection of hardware that consists of central storage, one or more central processors, timers, and channels.

**central site.** In a distributed data processing network, the central site is usually defined as the focal point for alerts, application design, and remote system management tasks such as problem management.

**CFR/CFS and ISC/ISR.** I/O operations can display and return data about integrated system channels (ISC) connected to a coupling facility and coupling facility receiver (CFR) channels and coupling facility sender (CFS) channels.

**channel.** A path along which signals can be sent; for example, data channel, output channel. See also *link*.

**channel path identifier.** A system-unique value assigned to each channel path.

**CHPID.** In System Automation for OS/390, channel path ID; the address of a channel.

**CHPID port.** A label that describes the system name, logical partitions, and channel paths.

**channel-attached.** (1) Attached directly by I/O channels to a host processor (for example, a channel-attached device). (2) Attached to a controlling unit by cables, rather than by telecommunication lines. Contrast with *link-attached*. Synonymous with *local*.

**CI.** Console integration.

**CICS/VS.** Customer Information Control System for Virtual Storage.

**CLIST.** Command list.

**clone.** A set of definitions for application instances which are derived from a basic application definition by substituting a number of different system-specific values into the basic definition.

**clone ID.** A generic means of handling system-specific values such as the MVS SYSCClone or the VTAM subarea number. Clone IDs can be substituted into application definitions and commands to customize a basic application definition for the system that it is to be instantiated on.

**CNC.** A channel path that transfers data between a host system image and an ESCON control unit. It can be point-to-point or switchable.

**command.** A request for the performance of an operation or the execution of a particular program.

**command facility.** The component of NetView that is a base for command processors that can monitor, control, automate, and improve the operation of a network. The successor to NCCF.

**command list (CLIST).** (1) A list of commands and statements, written in the NetView command list language or the REXX language, designed to perform a specific function for the user. In its simplest form, a command list is a list of commands. More complex command lists incorporate variable substitution and conditional logic, making the command list more like a conventional program. Command lists are typically interpreted rather than being compiled. (2) In System Automation for OS/390, REXX command lists that can be used for automation procedures.

**command procedure.** In NetView, either a command list or a command processor.

**command processor.** A module designed to perform a specific function. Command processors, which can be written in assembler or a high-level language (HLL), are issued as commands.

**common commands.** The System Automation for OS/390 subset of the CPC operations management commands.

**common routine.** One of several System Automation for OS/390 programs that perform frequently used automation functions. Common routines can be used to create new automation procedures.

**Common User Access (CUA) architecture.** Guidelines for the dialog between a human and a workstation or terminal.

**communication controller.** A type of communication control unit whose operations are controlled by one or more programs stored and executed in the unit or by a program executed in a processor to which the controller is connected. It manages the details of line control and the routing of data through a network.

**communication line.** Deprecated term for *telecommunication line*.

**communication path.** A set of communication facilities that System Automation for OS/390 uses to connect a focal-point system to a target system.

**configuration dialogs.** A user interface for entering the information that defines the System Automation for OS/390 configuration. In System Automation for OS/390 the configuration dialogs are an ISPF application.

**connectivity view.** In System Automation for OS/390, a display that uses graphic images for I/O devices and lines to show how they are connected.

**console automation.** The process of having NetView facilities provide the console input usually handled by the operator.

**console integration (CI).** A hardware facility which if supported by an operating system, allows operating system messages to be transferred through an internal hardware interface for display on a system console. Conversely, it allows operating system commands entered at a system console to be transferred through an internal hardware interface to the operating system for processing.

**consoles.** Workstations and 3270-type devices that manage your enterprise.

**Control units.** Hardware units that control I/O operations for one or more devices. You can view information about control units through I/O operations, and can start or stop data going to them by blocking and unblocking ports.

**controller.** A unit that controls I/O operations for one or more devices.

**couple data set.** A data set that is created through the XCF couple data set format utility and, depending on its designated type, is shared by some or all of the OS/390 systems in a sysplex. See also *sysplex couple data set* and *XCF couple data set*.

**coupling facility.** The hardware element that provides high-speed caching, list processing, and locking functions in a sysplex.

**CP.** Central processor.

**CPC.** Central processor complex.

**CPC operations management commands.** A set of commands and responses for controlling the operation of System/390 CPCs.

**CPC subset.** All or part of a CPC. It contains the minimum *resource* to support a single control program.

**CPCB.** Command processor control block; an I/O operations internal control block that contains information about the command being processed.

**CPU.** Central processing unit. Deprecated term for *processor*.

**cross-system coupling facility (XCF).** XCF is a component of OS/390 that provides functions to support cooperation between authorized programs running within a sysplex.

**CTC.** The channel-to-channel (CTC) channel can communicate with a CTC on another host for intersystem communication.

**Customer Information Control System (CICS).** A general-purpose transactional program that controls online communication between terminal users and a database for a large number of end users on a real-time basis.

**customization dialogs.** The customization dialogs are an ISPF application. They are used to customize the enterprise policy, like, for example, the enterprise resources and the relationships between resources, or the automation policy for systems in the enterprise. How to use these dialogs is described in *System Automation for OS/390 Customizing and Programming*.

**CVC.** A channel operating in converted (CVC) mode transfers data in blocks and a CBY channel path transfers data in bytes. Converted CVC or CBY channel paths can communicate with a parallel control unit. This resembles a point-to-point parallel path and dedicated connection, regardless whether it passes through a switch.

## D

**DASD.** Direct access storage device.

**data services task (DST).** The NetView subtask that gathers, records, and manages data in a VSAM file or a network device that contains network management information.

**data set.** The major unit of data storage and retrieval, consisting of a collection of data in one of several prescribed arrangements and described by control information to which the system has access.

**data set members.** Members of partitioned data sets that are individually named elements of a larger file that can be retrieved by name.

**DBCS.** Double-byte character set.

**DCCF.** Disabled console communication facility.

**DCF.** Document composition facility.

**DELAY Report.** An RMF report that shows the activity of each job in the system and the hardware and software resources that are delaying each job.

**Devices.** You can see information about all devices (such as printers, tape or disk drives, displays, or communications controllers) attached to a particular switch, and control paths and jobs to devices.

**DEVR Report.** An RMF report that presents information about the activity of I/O devices that are delaying jobs.

**dialog.** Interactive 3270 panels.

**direct access storage device (DASD).** A device in which the access time is effectively independent of the location of the data; for example, a disk.

**disabled console communication facility (DCCF).** An OS/390 component that provides limited-function console communication during system recovery situations.

**display.** (1) To present information for viewing, usually on the screen of a workstation or on a hard-copy device. (2) Deprecated term for *panel*.

**distribution manager.** The component of the NetView program that enables the host system to use, send, and delete files and programs in a network of computers.

**domain.** (1) An access method and its application programs, communication controllers, connecting lines, modems, and attached workstations. (2) In SNA, a system services control point (SSCP) and the physical units (PUs), logical units (LUs), links, link stations, and associated resources that the SSCP can control by means of activation requests and deactivation requests.

**double-byte character set (DBCS).** A character set, such as Kanji, in which each character is represented by a 2-byte code.

**DP enterprise.** Data processing enterprise.

**DSIPARM.** This file is a collection of members of NetView's DSIPARM data set. It determines how automation is applied to resources.

**DST.** Data Services Task.

## E

**EBCDIC.** Extended binary-coded decimal interchange code. A coded character set consisting of 8-bit coded characters.

**ECB.** Event control block. A control block used to represent the status of an event.

**EMCS.** Extended multiple console support.

**enterprise.** An organization, such as a business or a school, that uses data processing.

**enterprise monitoring.** Enterprise monitoring is used by System Automation for OS/390 to update the *NetView Graphic Monitor Facility (NGMF)* resource status information which is stored in the *Resource Object Data Manager (RODM)*. Resource status information is acquired by enterprise monitoring of the *Resource Measurement Facility (RMF) Monitor III* service information at user-defined intervals. System Automation for OS/390 stores this information in its operational information base, where it is used to update the information presented to the operator in graphic displays.

**entries.** Resources, such as processors, entered on panels.

**environment.** Data processing enterprise.

**error threshold.** An automation policy setting that specifies when System Automation for OS/390 should stop trying to restart or recover an application, subsystem or component, or offload a data set.

**ESA.** Enterprise Systems Architecture.

**eServer.** Processor family group designator used by the System Automation for OS/390 customization dialogs to define a target hardware as member of the zSeries or 390-CMOS processor families.

**event.** (1) In NetView, a record indicating irregularities of operation in physical elements of a network. (2) An occurrence of significance to a task; for example, the completion of an asynchronous operation, such as an input/output operation. (3) Events are part of a trigger condition, in a way that if all events of a trigger condition have occurred, a *STARTUP* or *SHUTDOWN* of an application is performed.

**exception condition.** An occurrence on a system that is a deviation from normal operation. System

Automation for OS/390 monitoring highlights exception conditions and allows an System Automation for OS/390 enterprise to be managed by exception.

**extended recovery facility (XRF).** A facility that minimizes the effect of failures in OS/390, VTAM, the host processor, or high availability applications during sessions between high availability applications and designated terminals. This facility provides an alternate subsystem to take over sessions from the failing subsystem.

## F

**fallback system.** See *secondary system*.

**field.** A collection of bytes within a record that are logically related and are processed as a unit.

**file manager commands.** A set of System Automation for OS/390 commands that read data from or write data to the automation control file or the operational information base. These commands are useful in the development of automation that uses System Automation for OS/390 facilities.

**focal point.** In NetView, the focal-point domain is the central host domain. It is the central control point for any management services element containing control of the network management data.

**focus host.** A processor with the role in the context of a unified system image

**focal-point system.** (1) A system that can administer, manage, or control one or more target systems. There are a number of different focal-point systems associated with IBM automation products. (2) **System Automation for OS/390 automation focal-point system.** The System Automation for OS/390 automation focal-point system is an System Automation for OS/390 NetView system that collects status information from other System Automation for OS/390 NetViews within your enterprise. It is supported by System Automation for OS/390, which uses NetView NNT/OST sessions to forward information to it. (3) **System Automation for OS/390 customization focal-point system.** The System Automation for OS/390 customization focal point is the system on which System Automation for OS/390 is installed. The System Automation for OS/390 policy databases exist on this system and are built into automation control file fragments, RODM load function files, and processor control file on this system (if this is being done using System Automation for OS/390). (4) **NGMF focal—point system.** The NGMF focal-point system is a NetView system with an attached workstation server and LAN which gathers information about the state of the network. This focal-point system uses RODM to store the data it collects in the GMFHS data model. The information stored in RODM can be accessed from any LAN-connected workstation with NetView Graphic Monitor Facility installed. (5) **NPDA**

**focal-point system.** This is a NetView system which collects all the NPDA alerts that are generated within your enterprise. It is supported by NetView. If you have System Automation for OS/390 installed the NPDA focal-point system must be the same as your NGMF focal-point system. The NPDA focal-point system is also known as the *alert focal-point system*. (6) **Status focal-point system.** In NetView, the system to which STATMON, VTAM and NLDM send status information on network resources. If you have a GMFHS focal point, it must be on the same system as the Status focal point. (7) **System Automation for OS/390 focal-point system.** This is a NetView system that has System Automation for OS/390 host code installed, and network connections to a number of System Automation for OS/390 workstations. The System Automation for OS/390 focal-point system receives messages from the systems and operator consoles of the machines it controls. It provides full systems and operations console function for its target systems. It can be used to IPL these systems. Note that some restrictions apply to the Hardware Management Console for an S/390 microprocessor cluster. (8) **Hardware Management Console.** Although not listed as a focal point, the Hardware Management Console acts as a focal point for the console functions of an S/390 microprocessor cluster. Unlike all the other focal points in this definition, the Hardware Management Console runs on a LAN-connected workstation,

**frame.** For a System/390 microprocessor cluster, a frame contains one or two central processor complexes (CPCs), support elements, and AC power distribution.

**full-screen mode.** In NetView, a form of panel presentation that makes it possible to display the contents of an entire workstation screen at once. Full-screen mode can be used for fill-in-the-blanks prompting. Contrast with *line mode*.

## G

**gateway session.** An NetView-NetView Task session with another system in which the System Automation for OS/390 outbound gateway operator logs onto the other NetView session without human operator intervention. Each end of a gateway session has both an inbound and outbound gateway operator.

**generic alert.** Encoded alert information that uses code points (defined by IBM and possibly customized by users or application programs) stored at an alert receiver, such as NetView.

**generic routines.** In System Automation for OS/390, a set of self-contained automation routines that can be called from the NetView automation table, or from user-written automation procedures.

**graphic workstation.** The graphic workstation is the primary way to dynamically monitor System

Automation for OS/390 systems. From the windows, you see messages, monitor status, view trends, and react to changes before they cause problems for end users. You can use multiple windows to monitor multiple views of the system.

**group.** A collection of target systems defined through configuration dialogs. An installation might set up a group to refer to a physical site or an organizational or application entity.

**Group entry.** A construct, created with the customization dialogs, used to represent and contain policy for a group.

## H

**Hardware Management Console.** A console used by the operator to monitor and control a System/390 microprocessor cluster.

**Hardware Management Console Application (HWMCA).** A direct-manipulation object-oriented graphical user interface that provides single point of control and single system image for hardware elements. HWMCA provides customer grouping support, aggregated and real-time system status using colors, consolidated hardware messages support, consolidated operating system messages support, consolidated service support, and hardware commands targeted at a single system, multiple systems, or a customer group of systems.

**heartbeat.** In System Automation for OS/390, a function which monitors the validity of the status forwarding path between remote systems and the NGMF focal point, and monitors the availability of remote OS/390 systems, to ensure that status information displayed on the System Automation for OS/390 workstation is current.

**help panel.** An online panel that tells you how to use a command or another aspect of a product.

**hierarchy.** In the NetView program, the resource types, display types, and data types that make up the organization, or levels, in a network.

**high-level language (HLL).** A programming language that does not reflect the structure of any particular computer or operating system. For the NetView program, the high-level languages are PL/I and C.

**HLL.** High-level language.

**host system.** In a coupled system or distributed system environment, the system on which the facilities for centralized automation run. System Automation for OS/390 publications refer to target systems or focal-point systems instead of hosts.

**host (primary processor).** The processor at which you enter a command (also known as the *issuing processor*).

**HWMCA.** Hardware Management Console Application. Application for the graphic hardware management console that monitors and controls a central processor complex. It is attached to a target processor (a system 390 microprocessor cluster) as a dedicated system console. This microprocessor uses OCF to process commands.

**images.** A grouping of processors and I/O devices that you define. You can define a single-image mode which allows a multiprocessor system to function as one central processor image.

**IMS/VS.** Information Management System/Virtual Storage.

**inbound.** In System Automation for OS/390, messages sent to the focal-point system from the PC or target system.

**inbound gateway operator.** The automation operator that receives incoming messages, commands, and responses from the outbound gateway operator at the sending system. The inbound gateway operator handles communications with other systems using a gateway session.

**Information Management System/Virtual Storage (IMS/VS).** A database/data communication (DB/DC) system that can manage complex databases and networks. Synonymous with IMS.

**INGEIO PROC.** The I/O operations default procedure name; part of the SYS1.PROCLIB.

**initial program load (IPL).** (1) The initialization procedure that causes an operating system to commence operation. (2) The process by which a configuration image is loaded into storage at the beginning of a workday or after a system malfunction. (3) The process of loading system programs and preparing a system to run jobs.

**initialize automation.** System Automation for OS/390-provided automation that issues the correct OS/390 start command for each subsystem when System Automation for OS/390 is initialized. The automation ensures that subsystems are started in the order specified in the automation control file and that prerequisite applications are functional.

**input/output support processor (IOSP).** The hardware unit that provides I/O support functions for the primary support processor and maintenance support functions for the processor controller.

**Interactive System Productivity Facility (ISPF).** An IBM licensed program that serves as a full-screen editor and dialog manager. Used for writing application programs, it provides a means of generating standard screen panels and interactive dialogs between the application programmer and the terminal user.

**interested operator list.** The list of operators who are to receive messages from a specific target system.

**internal token.** A *logical token* (LTOK); name by which the I/O resource or object is known; stored in IODF.

**IOCDs.** I/O configuration data set. The data set that describes the I/O configuration.

**I/O Ops.** See *I/O operations*.

**I/O resource exception monitoring.** I/O resource exception monitoring is a significant System Automation for OS/390 enhancement to the functions of enterprise monitoring. I/O resource exception monitoring dynamically notifies operations personnel when I/O resources fail or become inaccessible. System Automation for OS/390 reports I/O resource exceptions through the enterprise monitoring mechanisms, including NGMF-based graphic displays. If a change in the operational status of an I/O resource is detected by one System Automation for OS/390 system, the visual presentation and associated textual data of that resource is automatically updated for all System Automation for OS/390 focal—point systems. I/O resource exception monitoring does not require definition of the I/O resources to System Automation for OS/390. System Automation for OS/390 dynamically discovers those resources.

**IOSP.** Input/Output Support Processor.

**I/O operations.** The part of System Automation for OS/390 that provides you with a single point of logical control for managing connectivity in your active I/O configurations. I/O operations takes an active role in detecting unusual conditions and lets you view and change paths between a processor and an I/O device, using dynamic switching (the ESCON director).

**I/O resource number.** Combination of channel path identifier (CHPID), device number, etc. See internal token.

**IPL.** Initial program load.

**ISA.** Industry Standard Architecture.

**ISPF.** Interactive System Productivity Facility.

**ISPF console.** From this 3270-type console you are logged onto ISPF to use the runtime panels for I/O operations and System Automation for OS/390 customization panels.

**issuing host.** See *primary host*; the base program at which you enter a command for processing.

## J

**JCL.** Job control language.

**JES.** Job entry subsystem.

**job.** (1) A set of data that completely defines a unit of work for a computer. A job usually includes all necessary computer programs, linkages, files, and instructions to the operating system. (2) An address space.

**job control language (JCL).** A problem-oriented language designed to express statements in a job that are used to identify the job or describe its requirements to an operating system.

**job entry subsystem (JES).** A facility for spooling, job queuing, and managing I/O. In System Automation for OS/390 publications, JES refers to JES2 or JES3, unless distinguished as being either one or the other.

## K

**Kanji.** An ideographic character set used in Japanese. See also *double-byte character set*.

## L

**LAN.** Local area network.

**line mode.** A form of screen presentation in which the information is presented a line at a time in the message area of the terminal screen. Contrast with *full-screen mode*.

**link.** (1) In SNA, the combination of the link connection and the link stations joining network nodes; for example, a System/370 channel and its associated protocols, a serial-by-bit connection under the control of synchronous data link control (SDLC). (2) In System Automation for OS/390, link connection is the physical medium of transmission.

**link-attached.** Describes devices that are physically connected by a telecommunication line. Contrast with *channel-attached*.

**Linux for zSeries and S/390.** UNIX-like open source operating system conceived by Linus Torvalds and developed across the internet.

**local.** Pertaining to a device accessed directly without use of a telecommunication line. Synonymous with *channel-attached*.

**local area network (LAN).** (1) A network in which a set of devices is connected for communication. They

can be connected to a larger network. See also *token ring*. (2) A network in which communications are limited to a moderately sized geographic area such as a single office building, warehouse, or campus, and which do not generally extend across public rights-of-way.

**logical partition (LP).** A subset of the processor hardware that is defined to support an operating system. See also *logically partitioned (LPAR) mode*.

**logical switch number (LSN).** Assigned with the switch parameter of the CHPID macro of the IOCP.

**logical token (LTOK).** Resource number of an object in the IODF.

**logical unit (LU).** In SNA, a port through which an end user accesses the SNA network and the functions provided by system services control points (SSCPs). An LU can support at least two sessions — one with an SSCP and one with another LU — and may be capable of supporting many sessions with other LUs. See also *physical unit (PU)* and *system services control point (SSCP)*.

**logical unit (LU) 6.2.** A type of logical unit that supports general communications between programs in a distributed processing environment. LU 6.2 is characterized by (a) a peer relationship between session partners, (b) efficient use of a session for multiple transactions, (c) comprehensive end-to-end error processing, and (d) a generic application program interface (API) consisting of structured verbs that are mapped into a product implementation. Synonym for advanced program-to-program communications (APPC).

**logically partitioned (LPAR) mode.** A central processor mode that enables an operator to allocate system processor hardware resources among several logical partitions. Contrast with *basic mode*.

**LOGR.** The sysplex logger.

**LP.** Logical partition.

**LPAR.** Logically partitioned (mode).

**LU.** Logical unit.

**LU-LU session.** In SNA, a session between two logical units (LUs) in an SNA network. It provides communication between two end users, or between an end user and an LU services component.

**LU 6.2.** Logical unit 6.2.

**LU 6.2 session.** A session initiated by VTAM on behalf of an LU 6.2 application program, or a session initiated by a remote LU in which the application program specifies that VTAM is to control the session by using the APPCCMD macro.

## M

**MCS.** Multiple console support.

**member.** A specific function (one or more modules/routines) of a multisystem application that is defined to XCF and assigned to a group by the multisystem application. A member resides on one system in the sysplex and can use XCF services to communicate (send and receive data) with other members of the same group.

**message class.** A number that System Automation for OS/390 associates with a message to control routing of the message. During automated operations, the classes associated with each message issued by System Automation for OS/390 are compared to the classes assigned to each notification operator. Any operator with a class matching one of the message's classes receives the message.

**message forwarding.** The System Automation for OS/390 process of sending messages generated at a System Automation for OS/390 target system to the System Automation for OS/390 focal—point system.

**message group.** Several messages that are displayed together as a unit.

**message monitor task.** A task that starts and is associated with a number of communications tasks. Message monitor tasks receive inbound messages from a communications task, determine the originating target system, and route the messages to the appropriate target control tasks.

**message processing facility (MPF).** An OS/390 table that screens all messages sent to the OS/390 console. The MPF compares these messages with a customer-defined list of messages on which to automate, suppress from the OS/390 console display, or both, and marks messages to automate or suppress. Messages are then broadcast on the subsystem interface (SSI).

**message suppression.** The ability to restrict the amount of message traffic displayed on the OS/390 console.

**microprocessor.** A processor implemented on one or a small number of chips.

**migration.** Installation of a new version or release of a program to replace an earlier version or release.

**MP.** Multiprocessor.

**MPF.** Message processing facility.

**Multiple Virtual Storage (MVS).** An IBM licensed program. MVS, which is the predecessor of OS/390, is an operating system that controls the running of programs on a System/390 or System/370 processor.

MVS includes an appropriate level of the Data Facility Product (DFP) and Multiple Virtual Storage/Enterprise Systems Architecture System Product Version 5 (MVS/ESA SP5).

**multiprocessor (MP).** A CPC that can be physically partitioned to form two operating processor complexes.

**multisystem application.** An application program that has various functions distributed across OS/390 images in a multisystem environment.

**multisystem environment.** An environment in which two or more OS/390 images reside in one or more processors, and programs on one image can communicate with programs on the other images.

**MVS.** Multiple Virtual Storage, predecessor of OS/390.

**MVS image.** A single occurrence of the MVS/ESA operating system that has the ability to process work.

**MVS/JES2.** Multiple Virtual Storage/Job Entry System 2. An OS/390 subsystem that receives jobs into the system, converts them to internal format, selects them for execution, processes their output, and purges them from the system. In an installation with more than one processor, each JES2 processor independently controls its job input, scheduling, and output processing.

**MVS/ESA.** Multiple Virtual Storage/Enterprise Systems Architecture.

**MVS/ESA SP.** Multiple Virtual Storage/Enterprise Systems Architecture System Product.

**MVS/ESA SP4.** Multiple Virtual Storage/ Enterprise Systems Architecture System Product Version 4.

**MVS/XA.** Multiple Virtual Storage for Extended Architecture.

## N

**NAU.** (1) Network accessible unit. (2) Network addressable unit.

**NCCF.** Network Communications Control Facility.

**NCP.** (1) Network Control Program (IBM licensed program). Its full name is Advanced Communications Function for the Network Control Program. Synonymous with *ACF/NCP*. (2) Network control program (general term).

**NetView.** An IBM licensed program used to monitor a network, manage it, and diagnose network problems. NetView consists of a command facility that includes a presentation service, command processors, automation based on command lists, and a transaction processing structure on which the session monitor, hardware

monitor, and terminal access facility (TAF) network management applications are built.

**network accessible unit (NAU).** A logical unit (LU), physical unit (PU), control point (CP), or system services control point (SSCP). It is the origin or the destination of information transmitted by the path control network. Synonymous with *network addressable unit*.

**network addressable unit (NAU).** Synonym for *network accessible unit*.

**NetView automation procedures.** A sequence of commands, packaged as a NetView command list or a command processor written in a high-level language. An automation procedure performs automation functions and runs under the NetView program.

**NetView automation table.** A table against which the NetView program compares incoming messages. A match with an entry triggers the specified response. System Automation for OS/390 entries in the NetView automation table trigger a System Automation for OS/390 response to target system conditions.

**NetView Command list language.** An interpretive language unique to NetView that is used to write command lists.

**NetView (NCCF) console.** A 3270-type console for NetView commands and runtime panels for system operations and processor operations.

**NetView Graphic Monitor Facility (NGMF).** A function of the NetView program that provides a graphic, topological presentation of a network that is controlled by the NetView program. It provides the operator different views of a network, multiple levels of graphical detail, and dynamic resource status of the network. This function consists of a series of graphic windows that allows you to manage the network interactively.

**NetView hardware monitor.** The component of NetView that helps identify network problems, such as hardware, software, and microcode, from a central control point using interactive display techniques. Formerly called *network problem determination application*.

**NetView log.** The log in which NetView records events pertaining to NetView and System Automation for OS/390 activities.

**NetView message table.** See *NetView automation table*.

**NetView-NetView task (NNT).** The task under which a cross-domain NetView operator session runs. Each NetView program must have a NetView-NetView task to establish one NNT session. See *operator station task*.

**NetView paths via logical unit (LU 6.2).** A type of network-accessible port (VTAM connection) that

enables end users to gain access to SNA network resources and communicate with each other. LU 6.2 permits communication between processor operations and the workstation.

**NetView—NetView Task session.** A session between two NetView programs that runs under a NetView-NetView Task. In System Automation for OS/390, Netview-NetView Task sessions are used for communication between focal point and remote systems.

**network.** (1) An interconnected group of nodes. (2) In data processing, a user application network. See *SNA network*.

**Network Communications Control Facility (NCCF).** The operations control facility for the network. NCCF consists of a presentation service, command processors, automation based on command lists, and a transaction processing structure on which the network management applications NLDM and NPDA are built. NCCF is a precursor to the NetView command facility.

**Network Control Program (NCP).** An IBM licensed program that provides communication controller support for single-domain, multiple-domain, and interconnected network capability. Its full name is Advanced Communications Function for the Network Control Program.

**Networking NetView.** In System Automation for OS/390 the NetView that performs network management functions, such as managing the configuration of a network. In System Automation for OS/390 it is common to also route alerts to the Networking NetView.

**Network Problem Determination Application (NPDA).** An NCCF application that helps you identify network problems, such as hardware, software, and microcode, from a central control point using interactive display methods. The alert manager for the network. The precursor of the NetView hardware monitor.

**NGMF.** NetView Graphic Monitor Facility.

**NGMF focal—point system.** See *focal—point system*.

**NIP.** Nucleus initialization program.

**NNT.** NetView-NetView task.

**notification message.** A System Automation for OS/390 message sent to a human notification operator to provide information about significant automation actions. Notification messages are defined using the customization dialogs.

**notification operator.** A NetView console operator who is authorized to receive System Automation for

OS/390 notification messages. Authorization is made through the customization dialogs.

**NPDA.** Network Problem Determination Application.

**NPDA focal—point system.** See *focal—point system*.

**NTRI.** NCP/token-ring interconnection.

**nucleus initialization program (NIP).** The program that initializes the resident control program; it allows the operator to request last-minute changes to certain options specified during system generation.

## O

**objective value.** An average Workflow or Using value that System Automation for OS/390 can calculate for applications from past service data. System Automation for OS/390 uses the objective value to calculate warning and alert thresholds when none are explicitly defined.

**OCA.** In System Automation for OS/390, operator console A, the active operator console for a target system. Contrast with *OCB*.

**OCB.** In System Automation for OS/390, operator console B, the backup operator console for a target system. Contrast with *OCA*.

**OCF.** Operations command facility.

**OCF-based processor.** A central processor complex that uses an operations command facility for interacting with human operators or external programs to perform operations management functions on the CPC. Contrast with *screen-oriented processor*.

**OIB.** Operational Information Base, a depository of RODM, System Automation for OS/390 policy, and System Automation for OS/390 data model. Each System Automation for OS/390 OS/390 system with has its own OIB. The OIB on the focal—point system maintains the status information.

Policy is defined in the System Automation for OS/390 customization panels, stored and then loaded by a RODM load function file into OIB. Subsequent changes to customization are temporary until RODM again loads them into the OIB.

**OPC/A.** Operations Planning and Control/Advanced.

**OPC/ESA.** Operations Planning and Control/Enterprise Systems Architecture.

**operating system (OS).** Software that controls the execution of programs and that may provide services such as resource allocation, scheduling, input/output control, and data management. Although operating systems are predominantly software, partial hardware implementations are possible. (T)

**operations.** The real-time control of a hardware device or software function.

**operational data base.** See *OIB*.

**operational information base.** See *OIB*.

**operations command facility (OCF).** A facility of the central processor complex that accepts and processes operations management commands.

**Operations Planning and Control/Advanced (OPC/A).** A set of IBM licensed programs that automate, plan, and control batch workload. OPC/A analyzes system and workload status and submits jobs accordingly.

**Operations Planning and Control/ESA (OPC/ESA).** A set of IBM licensed programs that automate, plan, and control batch workload. OPC/ESA analyzes system and workload status and submits jobs accordingly. The successor to OPC/A.

**operator.** (1) A person who keeps a system running. (2) A person or program responsible for managing activities controlled by a given piece of software such as OS/390, the NetView program, or IMS. (3) A person who operates a device. (4) In a language statement, the lexical entity that indicates the action to be performed on operands.

**operator console.** (1) A functional unit containing devices that are used for communications between a computer operator and a computer. (T) (2) A display console used for communication between the operator and the system, used primarily to specify information concerning application programs and I/O operations and to monitor system operation. (3) In SA OS/390, a console that displays output from and sends input to the operating system (z/OS, LINUX, VM, VSE). Also called *operating system console*. In the System Automation for OS/390 operator commands and configuration dialogs, OC is used to designate a target system operator console.

**operator station task (OST).** The NetView task that establishes and maintains the online session with the network operator. There is one operator station task for each network operator who logs on to the NetView program.

**operator view.** A set of group, system, and resource definitions that are associated together for monitoring purposes. An operator view appears as a graphic display in the graphic interface showing the status of the defined groups, systems, and resources.

**OperatorView entry.** A construct, created with the customization dialogs, used to represent and contain policy for an operator view.

**OS.** Operating system.

**OS/390 component.** A part of OS/390 that performs a specific OS/390 function. In System Automation for OS/390, component refers to entities that are managed by System Automation for OS/390 automation.

**OS/390 subsystem.** Software products that augment the OS/390 operating system. JES and TSO/E are examples of OS/390 subsystems. System Automation for OS/390 includes automation for some OS/390 subsystems.

**OS/390 system.** An OS/390 image together with its associated hardware, which collectively are often referred to simply as a system, or OS/390 system.

**OSA.** I/O operations can display the open system adapter (OSA) channel logical definition, physical attachment, and status. You can configure an OSA channel on or off.

**OST.** Operator station task.

**outbound.** In System Automation for OS/390, messages or commands from the focal-point system to the target system.

**outbound gateway operator.** The automation operator that establishes connections to other systems. The outbound gateway operator handles communications with other systems through a gateway session. The automation operator sends messages, commands, and responses to the inbound gateway operator at the receiving system.

## P

**page.** (1) The portion of a panel that is shown on a display surface at one time. (2) To transfer instructions, data, or both between real storage and external page or auxiliary storage.

**panel.** (1) A formatted display of information that appears on a terminal screen. Panels are full-screen 3270-type displays with a monospaced font, limited color and graphics. (2) By using System Automation for OS/390 panels you can see status, type commands on a command line using a keyboard, configure your system, and passthru to other consoles. See also *help panel*. (3) In computer graphics, a display image that defines the locations and characteristics of display fields on a display surface. Contrast with *screen*.

**parallel channels.** Parallel channels operate in either byte (BY) or block (BL) mode. You can change connectivity to a parallel channel operating in block mode.

**parameter.** (1) A variable that is given a constant value for a specified application and that may denote the application. (2) An item in a menu for which the user specifies a value or for which the system provides a value when the menu is interpreted. (3) Data passed to

a program or procedure by a user or another program, namely as an operand in a language statement, as an item in a menu, or as a shared data structure.

**partition.** (1) A fixed-size division of storage. (2) In VSE, a division of the virtual address area that is available for program processing. (3) On an IBM Personal Computer fixed disk, one of four possible storage areas of variable size; one can be accessed by DOS, and each of the others may be assigned to another operating system.

**partitionable CPC.** A CPC that can be divided into 2 independent CPCs. See also *physical partition*, *single-image mode*, *MP*, *side*.

**partitioned data set (PDS).** A data set in direct access storage that is divided into partitions, called *members*, each of which can contain a program, part of a program, or data.

**passive monitoring.** In System Automation for OS/390, the receiving of unsolicited messages from OS/390 systems and their resources. These messages can prompt updates to resource status displays. See also *active monitoring*.

**PDS.** Partitioned data set.

**physical partition.** Part of a CPC that operates as a CPC in its own right, with its own copy of the operating system.

**physical unit (PU).** In SNA, the component that manages and monitors the resources (such as attached links and adjacent link stations) of a node, as requested by a system services control point (SSCP) through an SSCP-PU session. An SSCP activates a session with the physical unit to indirectly manage, through the PU, resources of the node such as attached links.

**physically partitioned (PP) configuration.** A mode of operation that allows a multiprocessor (MP) system to function as two or more independent CPCs having separate power, water, and maintenance boundaries. Contrast with *single-image (SI) configuration*.

**POI.** Program operator interface.

**policy.** The automation and monitoring specifications for an SA OS/390 enterprise. See *System Automation for OS/390 Defining Automation Policy*.

**policy database.** The database where the automation policy is recorded; also known as the OIB.

**POR.** Power-on reset.

**port.** (1) System hardware to which the I/O devices are attached. (2) On an ESCON switch, a port is an addressable connection. The switch routes data through the ports to the channel or control unit. Each port has a name that can be entered into a switch matrix, and you

can use commands to change the switch configuration. (3) An access point (for example, a logical unit) for data entry or exit. (4) A functional unit of a node through which data can enter or leave a data network. (5) In data communication, that part of a data processor that is dedicated to a single data channel for the purpose of receiving data from or transmitting data to one or more external, remote devices. (6) power-on reset (POR) (7) A function that re-initializes all the hardware in a CPC and loads the internal code that enables the CPC to load and run an operating system.

**PP.** Physically partitioned (configuration).

**PPT.** Primary POI task.

**primary host.** The base program at which you enter a command for processing.

**primary POI task (PPT).** The NetView subtask that processes all unsolicited messages received from the VTAM program operator interface (POI) and delivers them to the controlling operator or to the command processor. The PPT also processes the initial command specified to execute when NetView is initialized and timer request commands scheduled to execute under the PPT.

**primary system.** A system is a primary system for an application if the application is normally meant to be running there. System Automation for OS/390 starts the application on all the primary systems defined for it.

**problem determination.** The process of determining the source of a problem; for example, a program component, machine failure, telecommunication facilities, user or contractor-installed programs or equipment, environment failure such as a power loss, or user error.

**processor operations.** The part of System Automation for OS/390 that monitors and controls processor (hardware) operations. Processor operations provides a connection from a focal—point system to a target system. Through NetView on the focal —point system, processor operations automates operator and system consoles for monitoring and recovering target systems.

**processor operations control file.** Named by your system programmer, this file contains configuration and customization information. The programmer records the name of this control file in the processor operations file generation panel ISQDPG01.

**Processor Resource/Systems Manager (PR/SM).** The feature that allows the processor to use several operating system images simultaneously and provides logical partitioning capability. See also *LPAR*.

**ProcOps.** See *processor operations*.

**program to program interface (PPI).** A NetView function that allows user programs to send or receive data buffers from other user programs and to send alerts to the NetView hardware monitor from system and application programs.

**protocol.** In SNA, the meanings of, and the sequencing rules for, requests and responses used for managing the network, transferring data, and synchronizing the states of network components.

**PR/SM.** Processor Resource/Systems Manager.

**PU.** Physical unit.

## R

**remote system.** A system that receives resource status information from a System Automation for OS/390 focal—point system. A System Automation for OS/390 remote system is defined as part of the same System Automation for OS/390 enterprise as the System Automation for OS/390 focal—point system to which it is related.

**requester.** A requester is a workstation software, which enables users to log on to a domain, that is, to the server(s) belonging to this domain, and use the resources in this domain. After the log on to a domain, users can access the shared resources and use the processing capability of the server(s). Because the bigger part of shared resources is on the server(s), users can reduce hardware investment.

**resource.** (1) Any facility of the computing system or operating system required by a job or task, and including main storage, input/output devices, the processing unit, data sets, and control or processing programs. (2) In NetView, any hardware or software that provides function to the network. (3) In System Automation for OS/390, any OS/390 application, OS/390 component, job, device, or target system capable of being monitored or automated through System Automation for OS/390.

**Resource Access Control Facility (RACF).** A program that can provide data security for all your resources. RACF protects data from accidental or deliberate unauthorized disclosure, modification, or destruction.

**resource group.** A physically partitionable portion of a processor. Also known as a *side*.

**Resource Monitoring Facility (RMF) Monitor III.** A program that measures and reports on the availability and activity of system hardware and software resources, such as processors, devices, storage, and address spaces. RMF can issue online reports about system performance problems as they occur.

**Resource Object Data Manager (RODM).** A data cache manager designed to support process control and

automation applications. RODM provides an in-memory data cache for maintaining real-time data in an address space that is accessible by multiple applications. RODM also allows an application to query an object and receive a rapid response and act on it.

**resource token.** A unique internal identifier of an ESCON resource or resource number of the object in the IODF.

**restart automation.** System Automation for OS/390-provided automation that monitors subsystems to ensure that they are running. If a subsystem fails, System Automation for OS/390 attempts to restart it according to the policy in the automation control file.

**Restructured Extended Executor (REXX).** An interpretive language used to write command lists.

**return code.** A code returned from a program used to influence the issuing of subsequent instructions.

**REXX.** Restructured Extended Executor.

**REXX procedure.** A command list written with the Restructured Extended Executor (REXX) which is an interpretive language.

**RMF.** Resource Measurement Facility.

**RODM.** Resource Object Data Manager.

## S

**SAF.** Security Authorization Facility.

**system.** In System Automation for OS/390, the term system refers to a focal-point system (OS/390) or a target system.

**System Automation for OS/390 automation focal—point system.** See *focal—point system*.

**System Automation for OS/390 customization dialogs.** An ISPF application through which the System Automation for OS/390 policy administrator defines policy for individual OS/390 systems and builds automation control data and RODM load function files.

**System Automation for OS/390 customization focal—point system.** See *focal—point system*.

**System Automation for OS/390 data model.** The set of objects, classes and entity relationships necessary to support the function of System Automation for OS/390 and the NetView automation platform.

**System Automation for OS/390 enterprise.** The group of systems and resources defined in the customization dialogs under one enterprise name. A System

Automation for OS/390 enterprise consists of connected OS/390 systems running System Automation for OS/390.

**System Automation for OS/390 focal—point system.** See *focal—point system*.

**System Automation for OS/390 policy.** The description of the systems and resources that make up an System Automation for OS/390 enterprise, together with their monitoring and automation definitions.

**System Automation for OS/390 policy administrator.** The member of the operations staff who is responsible for defining System Automation for OS/390 policy.

**System Automation for OS/390 satellite.** If you are running two NetViews on an OS/390 system to split the automation and networking functions of NetView, it is common to route alerts to the Networking NetView. For System Automation for OS/390 to process alerts properly on the Networking NetView, you must install a subset of System Automation for OS/390 code, called an *System Automation for OS/390 satellite* on the Networking NetView.

**screen.** Deprecated term for display panel.

**screen-based processor.** See *screen-oriented processor*.

**SDF.** Status Display Facility.

**SDLC.** Synchronous data link control.

**SDSF.** System Display and Search Facility.

**secondary system.** A system is a secondary system for an application if it is defined to automation on that system, but the application is not normally meant to be running there. Secondary systems are systems to which an application can be moved in the event that one or more of its primary systems are unavailable. System Automation for OS/390 does not start the application on its secondary systems.

**server.** A server is a workstation, that shares resources, which include directories, printers, serial devices, and computing powers.

**service period.** Service periods allow the users to schedule the availability of applications. A service period is a set of time intervals (service windows), during which an application should be active.

**service threshold.** A System Automation for OS/390 policy setting that determines when to notify the operator of deteriorating service for a resource. See also *alert thresholdwarning threshold*.

**session.** In SNA, a logical connection between two network addressable units (NAUs) that can be activated, tailored to provide various protocols, and deactivated, as requested. Each session is uniquely identified in a transmission header by a pair of

network addresses identifying the origin and destination NAUs of any transmissions exchanged during the session.

**session monitor.** The component of the NetView program that collects and correlates session-related data and provides online access to this information. The successor to NLDL.

**shutdown automation.** System Automation for OS/390-provided automation that manages the shutdown process for subsystems by issuing shutdown commands and responding to prompts for additional information.

**SMP/E.** System Modification Program Extended.

**SNA.** Systems Network Architecture.

**SNA network.** In SNA, the part of a user-application network that conforms to the formats and protocols of systems network architecture. It enables reliable transfer of data among end users and provides protocols for controlling the resources of various network configurations. The SNA network consists of network addressable units (NAUs), boundary function components, and the path control network.

**SNMP.** Simple Network Management Protocol (a TCP/IP protocol). A protocol that allows network management by elements, such as gateways, routers, and hosts. This protocol provides a means of communication between network elements regarding network resources.

**solicited message.** A System Automation for OS/390 message that directly responds to a command. Contrast with *unsolicited message*.

**SSCP.** System services control point.

**SSI.** Subsystem interface.

**start automation.** System Automation for OS/390-provided automation that manages and completes the startup process for subsystems. During this process, System Automation for OS/390 replies to prompts for additional information, ensures that the startup process completes within specified time limits, notifies the operator of problems, if necessary, and brings subsystems to an UP (or ready) state.

**startup.** The point in time at which a subsystem or application is started.

**status.** The measure of the condition or availability of the resource.

**status focal—point system.** See *focal—point system*.

**status display facility (SDF).** The system operations part of System Automation for OS/390 that displays status of resources such as applications, gateways, and write-to-operator messages (WTORs) on dynamic

color-coded panels. SDF shows spool usage problems and resource data from multiple systems.

**steady state automation.** The routine monitoring, both for presence and performance, of subsystems, applications, volumes and systems. Steady state automation may respond to messages, performance exceptions and discrepancies between its model of the system and reality.

**structure.** A construct used by OS/390 to map and manage storage on a coupling facility. See *cache structure*, *list structure*, and *lock structure*.

**subgroup.** A named set of systems. A subgroup is part of a System Automation for OS/390 enterprise definition and is used for monitoring purposes.

**SubGroup entry.** A construct, created with the customization dialogs, used to represent and contain policy for a subgroup.

**subsystem.** (1) A secondary or subordinate system, usually capable of operating independent of, or asynchronously with, a controlling system. (2) In System Automation for OS/390, an OS/390 application or subsystem defined to System Automation for OS/390.

**subsystem interface.** The OS/390 interface over which all messages sent to the OS/390 console are broadcast.

**support element.** A hardware unit that provides communications, monitoring, and diagnostic functions to a central processor complex (CPC).

**support processor.** Another name given to a processor controller on smaller System/370 processors; see *service processor*.

**switches.** ESCON directors are electronic units with ports that dynamically switch to route data to I/O devices. The switches are controlled by I/O operations commands that you enter on a workstation.

**switch identifier.** The switch device number (swchdevn), the logical switch number (LSN) and the switch name

**symbolic destination name (SDN).** Used locally at the workstation to relate to the VTAM application name.

**SYSINFO Report.** An RMF report that presents an overview of the system, its workload, and the total number of jobs using resources or delayed for resources.

**SysOps.** See *system operations*.

**sysplex.** A set of OS/390 systems communicating and cooperating with each other through certain multisystem hardware components (coupling devices and timers) and software services (couple data sets).

In a sysplex, OS/390 provides the coupling services that handle the messages, data, and status for the parts of a multisystem application that has its workload spread across two or more of the connected processors, sysplex timers, coupling facilities, and couple data sets (which contains policy and states for automation).

A parallel sysplex is a sysplex which includes a coupling facility.

**sysplex application group.** A sysplex application group is a grouping of applications that can run on any system in a sysplex.

**sysplex couple data set.** A couple data set that contains sysplex-wide data about systems, groups, and members that use XCF services. All OS/390 systems in a sysplex must have connectivity to the sysplex couple data set. See also *couple data set*.

**Sysplex Timer.** An IBM unit that synchronizes the time-of-day (TOD) clocks in multiple processors or processor sides. External Time Reference (ETR) is the OS/390 generic name for the IBM Sysplex Timer (9037).

**system.** In System Automation for OS/390, system means a focal-point system (OS/390) or a target system.

**System Automation for OS/390.** The full name for SA OS/390.

**system console.** (1) A console, usually having a keyboard and a display screen, that is used by an operator to control and communicate with a system. (2) A logical device used for the operation and control of hardware functions (for example, IPL, alter/display, and reconfiguration). The system console can be assigned to any of the physical displays attached to a processor controller or support processor. (3) In System Automation for OS/390, the hardware system console for processor controllers or service processors of processors connected using System Automation for OS/390. In the System Automation for OS/390 operator commands and configuration dialogs, SC is used to designate the system console for a target hardware processor.

**System Display and Search Facility (SDSF).** An IBM licensed program that provides information about jobs, queues, and printers running under JES2 on a series of panels. Under System Automation for OS/390 you can select SDSF from a pull-down menu to see the resources' status, view the OS/390 system log, see WTOR messages, and see active jobs on the system.

**System entry.** A construct, created with the customization dialogs, used to represent and contain policy for a system.

**System Modification Program/Extended (SMP/E).** An IBM licensed program that facilitates the process of installing and servicing an OS/390 system.

**system operations.** The part of System Automation for OS/390 that monitors and controls system operations applications and subsystems such as NetView, SDSF, JES, RMF, TSO, RODM, ACF/VTAM, CICS, IMS, and OPC.

**system services control point (SSCP).** In SNA, the focal point within an SNA network for managing the configuration, coordinating network operator and problem determination requests, and providing directory support and other session services for end users of the network. Multiple SSCPs, cooperating as peers, can divide the network into domains of control, with each SSCP having a hierarchical control relationship to the physical units and logical units within its domain.

**Systems Network Architecture (SNA).** The description of the logical structure, formats, protocols, and operational sequences for transmitting information units through, and controlling the configuration and operation of, networks.

**SystemView.** An IBM structure applied to systems management applications to produce a unified and consistent set of applications to the systems management end user.

**System/390 microprocessor cluster.** A configuration that consists of central processor complexes (CPCs) and may have one or more integrated coupling facilities.

## T

**TAF.** Terminal access facility.

**target.** A processor or system monitored and controlled by a focal—point system.

**target control task.** In System Automation for OS/390, target control tasks process commands and send data to target systems and workstations through communications tasks. A target control task (a NetView autotask) is assigned to a target system when the target system is initialized.

**target hardware.** In System Automation for OS/390, the physical hardware on which a target system runs. It can be a single-image or physically partitioned processor. Contrast with *target system*.

**target system.** (1) In a distributed system environment, a system that is monitored and controlled by the focal-point system. Multiple target systems can be controlled by a single focal-point system. (2) In System Automation for OS/390, a computer system attached to the focal-point system for monitoring and control. The definition of a target system includes how remote sessions are established, what hardware is used, and what operating system is used.

**task.** (1) A basic unit of work to be accomplished by a computer. (2) In the NetView environment, an operator station task (logged-on operator), automation operator (autotask), application task, or user task. A NetView task performs work in the NetView environment. All System Automation for OS/390 tasks are NetView tasks. See also *communications task*, *message monitor task*, and *target control task*.

**telecommunication line.** Any physical medium, such as a wire or microwave beam, that is used to transmit data.

**terminal access facility (TAF).** (1) A NetView function that allows you to log onto multiple applications either on your system or other systems. You can define TAF sessions in the System Automation for OS/390 customization panels so you don't have to set them up each time you want to use them. (2) In NetView, a facility that allows a network operator to control a number of subsystems. In a full-screen or operator control session, operators can control any combination of subsystems simultaneously.

**terminal emulation.** The capability of a microcomputer or personal computer to operate as if it were a particular type of terminal linked to a processing unit to access data.

**threshold.** A value that determines the point at which System Automation for OS/390 automation performs a predefined action. See *alert threshold*, *warning threshold*, and *error threshold*.

**Time Sharing Option (TSO).** An optional configuration of the operating system that provides conversational time sharing from remote stations. It is an interactive service on OS/390, MVS/ESA, and MVS/XA.

**Time-Sharing Option/Extended (TSO/E).** An option of OS/390 that provides conversational time-sharing from remote terminals. TSO/E allows a wide variety of users to perform many different kinds of tasks. It can handle short-running applications that use fewer sources as well as long-running applications that require large amounts of resources.

**timers.** A NetView command that issues a command or command processor (list of commands) at a specified time or time interval.

**TME 10.** Tivoli Management Environment.

**TOD.** Time of day.

**token ring.** A network with a ring topology that passes tokens from one attaching device to another; for example, the IBM Token-Ring Network product.

**TP.** Transaction program.

**transaction program.** In the VTAM program, a program that performs services related to the processing of a transaction. One or more transaction programs may operate within a VTAM application program that is using the VTAM application program interface (API). In that situation, the transaction program would request services from the applications program using protocols defined by that application program. The application program, in turn, could request services from the VTAM program by issuing the APPCCMD macro instruction.

**transitional automation.** the actions involved in starting and stopping subsystems and applications which have been defined to System Automation for OS/390. This can include issuing commands and responding to messages.

**translating host.** Role played by a host that turns a resource number into a token during a unification process.

**trigger.** Triggers, in combination with events and service periods, are used to control the starting and stopping of applications in a single system or a parallel sysplex.

**TSO.** Time Sharing Option.

**TSO console.** From this 3270-type console you are logged onto TSO or ISPF to use the runtime panels for I/O operations and System Automation for OS/390 customization panels.

**TSO/E.** TSO Extensions.

## U

**UCB.** The unit control block; an MVS/ESA data area that represents a device and which is used for allocating devices and controlling I/O operations.

**unsolicited message.** A System Automation for OS/390 message that is not a direct response to a command. Contrast with *solicited message*.

**user task.** An application of the NetView program defined in a NetView TASK definition statement.

**Using.** An RMF Monitor III definition. Jobs getting service from hardware resources (processors or devices) are **using** these resources. The use of a resource by an address space can vary from 0% to 100% where 0% indicates no use during a Range period, and 100% indicates that the address space was found using the resource in every sample during that period. See also *Workflow*.

## V

**view.** In the NetView Graphic Monitor Facility, a graphical picture of a network or part of a network. A

view consists of nodes connected by links and may also include text and background lines. A view can be displayed, edited, and monitored for status information about network resources.

**Virtual Machine/System Product (VM/SP).** An IBM licensed program. It is an operating system that manages the resources of a real processor to provide virtual machines to end users. As a time-sharing system control program, it consists of the virtual machine control program (CP), the conversational monitor system (CMS), the group control system (GCS), and the interactive problem control system (IPCS).

**Virtual Storage Extended (VSE).** An IBM licensed program whose full name is Virtual Storage Extended/Advanced Function. It is an operating system that controls the execution of programs.

**Virtual Telecommunications Access Method (VTAM).** An IBM licensed program that controls communication and the flow of data in an SNA network. It provides single-domain, multiple-domain, and interconnected network capability. Its full name is Advanced Communications Function for the Virtual Telecommunications Access Method. Synonymous with *ACF/VTAM*.

**VM/ESA.** Virtual Machine/Enterprise Systems Architecture.

**VM/SP.** Virtual Machine/System Product.

**VM/SP HPO.** Virtual Machine/System Product High Performance Option.

**volume.** A direct access storage device (DASD) volume or a tape volume that serves a system in a System Automation for OS/390 enterprise.

**volume entry.** A construct, created with the customization dialogs, used to represent and contain policy for a volume.

**volume group.** A named set of volumes. A volume group is part of a system definition and is used for monitoring purposes.

**volume group entry.** An construct, created with the customization dialogs, used to represent and contain policy for a volume group.

**Volume Workflow.** The System Automation for OS/390 Volume Workflow variable is derived from the RMF Resource Workflow definition, and is used to measure the performance of volumes. System Automation for OS/390 calculates Volume Workflow using:

$$\text{Volume Workflow \%} = \frac{\text{accumulated Using}}{\text{accumulated Using} + \text{accumulated Delay}} * 100$$

The definition of **Using** is the percentage of time when a job has had a request accepted by a channel for the volume, but the request is not yet complete.

The definition of **Delay** is the delay that waiting jobs experience because of contention for the volume. See also *Address Space Workflow*.

**VSE.** Virtual Storage Extended.

**VTAM.** Virtual Telecommunications Access Method.

## W

**warning threshold.** An application or volume service value that determines the level at which System Automation for OS/390 changes the associated icon in the graphic interface to the warning color. See *alert threshold*.

**workflow.** See *Address Space Workflow* and *Volume Workflow*.

**write-to-operator (WTO).** A request to send a message to an operator at the OS/390 operator console. This request is made by an application and is handled by the WTO processor, which is part of the OS/390 supervisor program.

**write-to-operator-with-reply (WTOR).** A request to send a message to an operator at the OS/390 operator console which requires a response from the operator. This request is made by an application and is handled by the WTO processor, which is part of the OS/390 supervisor program.

**WTO.** Write-to-Operator.

**WTOR.** Write-to-Operator-with-Reply.

**WWV.** The US National Institute of Standards and Technology (NIST) radio station that provides standard time information. A second station, known as WWVB, provides standard time information at a different frequency.

## X

**XCF.** Cross-system coupling facility.

**XCF couple data set.** The name for the sysplex couple data set prior to MVS/ESA System Product Version 5 Release 1. See also *sysplex couple data set*.

**XCF group.** A set of related members that a multisystem application defines to XCF. A member is a specific function, or instance, of the application. A member resides on one system and can communicate with other members of the same group across the sysplex.

**XRF.** Extended recovery facility.

## Numerics

**390-CMOS.** Processor family group designator used in the System Automation for OS/390 processor operations documentation and in the online help to identify any of the following S/390 CMOS processor machine types: 9672, 9674, 2003, 3000, or 7060. System Automation for OS/390 processor operations uses the OCF facility of these processors to perform operations management functions. See *OCF-based processor*.

---

# Index

## A

- ACF command dialog 14
- ACF file manager command 14
- ACTIVATE command
  - description 263
  - status checks 287
- active
  - ACTIVE=SAVED on ESCD 340
- adding
  - your userid to the interested operator list 326
- ALLOW command 212
- alternate CDS
  - allocating 138
  - spare volumes 138
  - turn into primary CDS 138
- AOCHELP command dialog 16
- AOCTRACE command dialog 17
- AOFDEBUG command 17
- API
  - Query command rules 354
- application 5
  - related events 31, 33
- assigning names
  - WRITE command 257
- assist mode 198
- attribute hierarchy 345
- attributes 349
- authorization levels 351
- automatic connectivity checks 334
- automation
  - from status message 318
  - keywords 313
  - turning flags on or off 71
- automation control file
  - saving 14
  - warm startup 14
- automation control file WARM start 14
- automation manager commands
  - INGAMS 65
  - INGEVENT 95
  - INGFILT 97
  - INGINFO 115
  - INGLIST 117
  - INGRELS 154
  - INGREQ 156
  - INGRPT 163
  - INGSCHED 165
  - INGSET 178
  - INGTOPO 187
  - INGTRIG 188
  - INGVOTE 190
- automation operators
  - determining active 20

## B

- backout option 341
- backout processing 338
- BLOCK command 214

## C

- cancelling a console lock
  - with ISQXUNL 330
- cascaded switch
  - FICON 211
- CBU command
  - description 276
- CFRM policy
  - pending changes 91, 138
  - policy switch 85
- chain
  - planning 334
  - ports 334
- CHAIN command 216
- chained path
  - examples 334
  - vary path requests 349
- changing values 308
- channel
  - CVC 343
  - DISPLAY CHP command 221
  - parallel 347
  - REMOVE CHP command 241
- closing
  - a target system with ISQXCLS 318
- command
  - authorization level 351
  - availability 351
  - command failures 337
  - command output
    - port I/O definition 342
  - command routing mechanism 172
- commands
  - ACF 14
  - ACTIVATE 263
  - ALLOW 212
  - AOCHELP 16
  - AOCTRACE 17
  - AOFDEBUG 17
  - BLOCK 214
  - CBU 276
  - CHAIN 216
  - common 261
  - CONNECT 219
  - DEACTIVATE 277
  - DISCONNECT 220
  - DISPACF 19
  - DISPAOPS 20
  - DISPASF 22
  - DISPASST 24
  - DISPAUTO 26
  - DISPERRS 29
  - DISPEVT 31
  - DISPEVTS 33
  - DISPFLGS 35
  - DISPGW 37
  - DISPINFO 42
  - DISPLAY CHP 221
  - DISPLAY DEVICE 223
  - DISPLAY HOST 225
  - DISPLAY NAME 227

## commands (continued)

- DISPLAY PORT 229
- DISPLAY RESULTS 231
- DISPLAY SWITCH 234
- DISPLAY TIMEOUT 236
- DISPLAY VARY 236
- DISPMSGs 44
- DISPNTFY 46
- DISPSCHD 47
- DISPSTAT 51
- DISPSYS 56
- DISPTREE 58
- DISPTRG 59
- DISPWTOR 61
- DRAINJES 62
- EXPLAIN 63
- EXTINT 281
- GETLOCK 238
- GWTRACE 64
- host-based 261
- INGAMS 65
- INGAUTO 71
- INGCF 73
- INGCF DRAIN 79
- INGCF ENABLE 84
- INGCF PATH 88
- INGCF STRUCTURE 89
- INGCFL 91
- INGCICS 92
- INGEVENT 95
- INGFILT 97
- INGGROUP 100
- INGHC 103
- INGHIST 110
- INGIMS 112
- INGINFO 115
- INGLIST 117
- INGLKUP 121
- INGNTFY 123
- INGOPC 125
- INGPLEX 132
- INGPLEX BESTpractices 135
- INGPLEX CDS 137
- INGPLEX CONSOLE 145
- INGPLEX IPL 147
- INGPLEX SDUMP 148
- INGPLEX SLIP 153
- INGPLEX SVCDUMP 151
- INGPLEX SYTEM 143
- INGREG 156
- INGRELS 154
- INGRPT 163
- INGSCHED 165
- INGSEND 172, 175
- INGSET 178
- INGTHRES 181
- INGTIMER 185
- INGTOPO 187
- INGTRIG 188
- INGVOTE 190
- INGVTAM 193

commands (continued)

- ISQCCMD 297
- ISQCMON 299
- ISQEXEC 300
- ISQHELP 301
- ISQOVRD 303
- ISQSEND 304
- ISQSTART 305
- ISQSTOP 307
- ISQVARS 308
- ISQXCLS 318
- ISQXDRL 319
- ISQXDST 320
- ISQXIII 323
- ISQXLOC 325
- ISQXMON 326
- ISQXOPT 328
- ISQXUNL 330
- JES2 194
- LOAD 283
- LOGREC 238
- MONITOR 195
- PROHIBIT 239
- Query rules 354
- REMOVE CHP 241
- REMOVE SWITCH 243
- RESET HOST 245
- RESET SWITCH 248
- RESET TIMEOUT 248
- RESTART 196
- RESTORE CHP 249
- RESTORE SWITCH 251
- RESYNC 197
- SETASST 198
- SETHOLD 201
- SETSTATE 202
- SETTIMER 205
- START 289
- STOP 290
- SYNC SWITCH 252
- SYSRESET 291
- types 261
- UNBLOCK 253
- UNCHAIN 254
- UNLOCK 256
- varying paths 349
- WRITE 257

common commands 261

- commands
  - processor operations
    - commands 261
  - DEACTIVATE 277
  - EXTINT 281
  - ISQCCMD 297
  - RESTART 288
  - START 289
  - STOP 290
  - SYSRESET 291

CONNECT command 219

connectivity

- backout option 341
- chained paths 349
- force option 341
- making changes to 340
- nobackout option 341
- nocheck option 341
- noforce|nocheck|force 340

connectivity (continued)

- port attributes 349
- UNBLOCK command 253
- varying paths 349

console

- cancelling a lock with ISQXUNL 330

consoles

- closing with ISQXCLS 318
- locking access 325

converter

- CVC channel 343

converter in CVC path 343

couple data set (CDS)

- alternate CDS
  - allocating 138
  - spare volumes 138
  - turn into primary CDS 138

coupling facility

- channels 339

coupling facility (CF)

- draining 79
- enabling 84, 85
- populating 85
- receiver path 75
- sender path 80, 85
- states 75

CPCB (command processor control block) 361

CRM 172

CU chain 334

CV converter

- support 347

CVC channel 343

## D

D R,L command (MVS) 319, 320

DEACTIVATE command

- command 277
- reinitialize 281

debugging 64

deleting

- your userid from the interested operator list 326

destination switch 334

device

- DISPLAY DEVICE command. 223

disabling a switch 344

DISCONNECT command 220

DISPACF command dialog 19

DISPAOPS command 20

DISPASF command 22

DISPASST command 24

DISPAUTO command 26

DISPERRS command 29

DISPEVT command 31

DISPEVTS command 33

DISPFLGS command 35

DISPGW command 37

DISPINFO command 42

DISPLAY CHP command 221

DISPLAY HOST command 225

DISPLAY NAME 227

DISPLAY PORT command 229

DISPLAY RESULTS command 231

display results of commands 231

DISPLAY SWITCH command 234

DISPLAY TIMEOUT command 236

DISPLAY VARY command 236

displaying

- target system information 328

displaying outstanding MVS requests 319

displaying status panels

- with ISQXDST 320

DISPMSGs command 44

DISPNTFY command 46

DISPSCHD command 47

DISPSTAT command 51

DISPSYS command 56

DISPTREE command 58

DISPTRG command 59

DISPWTOR command 61

distributed feature code

- starting with ISQXIII 323

documents, licensed xiv

DRAINJES command dialog 62

DSIPARM

- description 362

duplexing

- system-managed 90
- user-managed 90

dynamic connection

- PROHIBIT 239

## E

enter a console command for

- automation 304
- error recovery 338

establish processor operations

- environment 305

event

- related application 31, 33

EXPLAIN command 63

EXTINT command 281

## F

failed commands 337

FICON casceaded switches 211

FICON switches 211

file manager commands

- ACF 14

flags 71

focal-point ports

- disable 281

force option 341

## G

gateway sessions 37

- using INGSSEND 175

generic routine

- INGTIMER 185

GETLOCK command 238

getting help

- ISQHELP command 301

graphic workstation description 363

GWTRACE command dialog 64

## H

- hardware status 344
- help
  - EXPLAIN command dialog 63
  - for commands 16
  - with a command 301
- hierarchy of port attributes 345
- host
  - primary 348
- host response time-out 248
- host-based commands 261
- HWMCA
  - description 364

## I

- I/O operations
  - inter-I/O operations
    - communication 245
- I/O operations commands
  - ALLOW 212
  - BLOCK 214
  - CHAIN 216
  - CONNECT 219
  - DISCONNECT 220
  - DISPLAY CHP 221
  - DISPLAY DEVICE 223
  - DISPLAY HOST 225
  - DISPLAY NAME 227
  - DISPLAY PORT 229
  - DISPLAY RESULTS 231
  - DISPLAY SWITCH 234
  - DISPLAY TIMEOUT 236
  - DISPLAY VARY 236
  - GETLOCK 238
  - LOGREC 238
  - PROHIBIT 239
  - REMOVE CHP 241
  - REMOVE SWITCH 243
  - RESET HOST 245
  - RESET SWITCH 248
  - RESET TIMEOUT 248
  - RESTORE CHP 249
  - RESTORE SWITCH 251
  - SYNC SWITCH 252
  - UNBLOCK 253
  - UNCHAIN 254
  - UNLOCK 256
  - WRITE 257
- identifier
  - switch 333, 334
- IEA101A message 315, 317
- IEA212A message 315
- IEA347A message 315, 317
- INGAMS command 65
- INGAUTO command 71
- INGCF command 73
  - authorizations 74
  - DRAIN 79
  - ENABLE 84
  - PATH 88
  - STRUCTURE 89
- INGCFL command 91
- INGCICS command 92
- INGEIO 364
- INGEVENT command 95
- INGFILT command 97
- INGGROUP command 100
- INGHC command 103
- INGHIST command 110
- INGIMS command 112
- INGINFO command 115
- INGLIST command 117
- INGLKUP 121
- INGNTFY command 123
- INGOPC command 125
- INGPLEX command 132
  - BESTpractices 135
  - CDS 137
  - CONSOLE 145
  - IPL 147
  - SDUMP 148
  - SLIP 153
  - SVCDUMP 151
  - SYSTEM 143
- INGRELS command 154
- INGREQ command 156
- INGRPT command 163
- INGSCHED command 165
- INGSEND command 172, 175
- INGSEND command dialog 172
- INGSET command 178
- INGTHRES command 181
- INGTIMER command 185
- INGTOPO command 187
- INGTRIG command 188
- INGVOTE command 190
- INGVTAM command 193
- initial status determination 197
- initializing
  - a target system
    - with ISQXIII 323
- interested operator list
  - adding or deleting your userid 326
  - ISQSTART command 300
  - viewing 320
- intersystem communication
  - DISPLAY HOST command 225
  - DISPLAY TIMEOUT 236
- intersystem communications 245
- IODF 75
- IPL
  - ACTIVATE common command 263
  - LOAD common command 283
- ISQCCMD command 297
- ISQCHK command 298
- ISQCMON command 299
  - issued by ISQSTART 306
- ISQEXEC command 300
  - usage with ISQXLOC 325
- ISQHLP command 301
- ISQOVRD command 303
- ISQSEND command 304
  - limited by ISQXCLS 319
- ISQSTART command 305
- ISQSTOP command 307
- ISQVARS command 308, 315
  - called by ISQXOPT 329
- ISQXCLS command 318
- ISQXDRL command 319
- ISQXDST command 320
  - target system status values 322
- ISQXIII command 323

- ISQXIPL command
  - check status 287
- ISQXLOC command 325
  - usage with ISQXUNL 330
- ISQXMON command 326
- ISQXOPT command 328
- ISQXUNL command 330
  - description 330
  - usage with ISQXLOC 325

## J

- JES2
  - command 194
  - draining resources 62

## K

- keywords
  - ISQVARS 315
  - sorted by keyword name 315
- keywords and status messages 315

## L

- licensed documents xiv
- LOAD command 283
- locking console access 325
- locks
  - cancelling a console lock 330
- logical switch number 333, 334
- logical tokens 342
- logical-to-physical coordination 252
- LOGREC command 238
- LookAt message retrieval tool xiii
- LSN 334
  - switch identifier 333

## M

- mask
  - allow | prohibit 342
- message holding parameters 201
- message retrieval tool, LookAt xiii
- messages
  - IEA101A 315, 317
  - IEA212A 315
  - IEA347A 315, 317
  - ISQCMON command 299
  - status 313, 315
- MONITOR command 195
- MVS
  - displaying outstanding requests 319
- MVS commands
  - D R,L command 319, 320
  - QUIESCE 281
- MVSESA.RELOAD.ACTION flag 15
- MVSESA.RELOAD.CONFIRM flag 15

## N

- name
  - generic 343
  - port 343
  - VTAM 350

- names
  - WRITE command 257
- naming a port 343
- NetView
  - establishing processor operations 305
  - RMTCMD 172
- NetView commands
  - View 329
- NetView save/restore facility 14
- NGMF focal—point system 362
- nobackout option 341
- nocheck option 341
- noforce option 340

## O

- OPRCTL panel 288
- OUTDSN parameter 12
- OUTMODE parameter 12
- outstanding WTORS
  - displaying 61

## P

- panels
  - AOCHELP 17
  - Authorized Message Receivers 45
  - Automation Operators 22
  - Autoterm Status 64
  - Command Dialogs 11, 12
  - Command Response 20, 24
  - Command Response Display 195
  - DISPAOPS 22
  - DISPASF 24
  - DISPASST 25
  - DISPAUTO 29
  - DISPERRS 29, 30
  - DISPEVT 31, 32
  - DISPEVTS 33, 34, 35
  - DISPFLGS 35, 36
  - DISPGW 37
  - DISPINFO 42, 43, 44
  - DISPMSGs 44
  - DISPNTFY 46, 47
  - DISPSCHD 47, 48
  - DISPSFLT 51
  - DISPSTAT 51, 54, 55, 56
  - DISPSYS 56, 57
  - DISPTREE 58, 59
  - DISPTRG 59, 60
  - DISPWTOR 61, 62
  - EXPLAIN 63
  - GATEWAY DISPLAY 38, 40, 41
  - INGAMS 67, 69, 70
  - INGAUTO 71
  - INGCICS 94, 95
  - INGFILT 100
  - INGHIST 112
  - INGIMS 114, 115
  - INGINFO 5, 116
  - INGLIST 119, 120
  - INGLKUP 123
  - INGNTFY 123, 125
  - INGOPC 128, 129, 130, 131
  - INGRELS 156
  - INGREQ 162, 163
- panels (*continued*)
  - INGSCHED 168, 169, 170, 171, 172
  - INGTHRES 184, 185, 206
  - INGTRIG 189, 190
  - INGVOTE 192
  - ISQXDST 322
  - RESYNC 197
  - SETASST 198
  - SETHOLD 201
  - SETSTATE 202, 205
  - SETTIMER 205, 206
  - Target System Options 329
  - TIMER 206
- parallel channel
  - support 347
- parameters
  - additional, for System Operations
    - commands
      - OUTDSN 12
      - OUTMODE 12
      - TARGET 10
- passthru switch 334
- path
  - chain 334
- pending policy changes 91, 138
- physical tokens 343
- policy
  - switch 138
- port
  - allow | prohibit mask 342
  - name 343
  - port attributes 349
  - status 344
- Port address
  - DISPLAY PORT command 229
- port attribute hierarchy 345
- port I/O definition 342
- port name 343
  - assigning (WRITE command) 257
  - DISPLAY NAME command 227
- primary host 348
- problems
  - correcting 338
  - issuing ISQSEND with ISQXDRL 320
- processing failures 338
- processing lock
  - UNLOCK command 256
- processor operations
  - check if active 298
  - issuing commands 261
  - stopping 307
- processor operations commands
  - ACTIVATE 263
  - CBU 276
  - DEACTIVATE 277
  - EXTINT 281
  - ISQCCMD 297
  - ISQCHK 298
  - ISQCMON 299
  - ISQEXEC 300
  - ISQHELP 301
  - ISQOVRD 303
  - ISQSEND 304
  - ISQSTART 305
  - ISQSTOP 307
  - ISQVARS 308
  - ISQXCLS 318

- processor operations commands
  - (*continued*)
    - ISQXDRL 319
    - ISQXDST 320
    - ISQXIII 323
    - ISQXLOC 325
    - ISQXMON 326
    - ISQXOPT 328
    - ISQXUNL 330
    - LOAD 283
    - RESTART 288
    - START 289
    - STOP 290
    - SYSRESET 291
- program status word (PSW)
  - loading 288
- PROHIBIT command 239

## Q

- Query commands
  - rules 354
- QUIESCE command (MVS) 281
- quiescing a ESCON Director
  - REMOVE SWITCH 243

## R

- rebuild 80, 90
  - system-managed 80, 90
  - user-managed 80, 90
- receiver path 75
- recovery automation flag 71
- refreshing configuration data,
  - INGAMS 65
- reload action flag 15
- reload confirm flag 15
- RELOAD.ACTION flag 15
- RELOAD.CONFIRM flag 15
- REMOVE CHP command 241
- REMOVE SWITCH command 243
- removing
  - a switch 344
- RESET HOST command 245
- RESET SWITCH command 248
- RESET TIMEOUT command 248
- resetting
  - target processor 291
- resource 3
- RESTART command 196, 288
- RESTORE CHP command 249
- RESTORE SWITCH command 251
- restoring
  - a switch 342
- restrictions on ISQCMON
  - do not issue with ISQEXEC 300
- restrictions on VSE
  - no operator console messages 327
- restrictions with ISQSTOP 307
- restrictions with ISQXDST.
  - do not issue from an automation
    - procedure 321
  - do not issue with ISQEXEC 321
- RESYNC command 197
- RMTCMD command 172
- ROUTE command 172

routine monitor 195  
routing commands  
    with INGSEND 172, 175

## S

saved  
    ACTIVE=SAVED on ESCD 340  
saving an automation control file 14  
sender path 80, 85  
service language commands  
    entering with ISQSEND 304  
SETASST command 198  
SETHOLD command 201  
SETSTATE command 202  
SETTIMER command 205  
shutdown procedure 307  
simulate pressing a console key 304  
SLIP TRAP 153  
specifying resources 4  
START command 289  
starting  
    a target processor 289  
static connection  
    DISCONNECT command 220  
static connections 219  
status  
    changing with SETSTATE 202  
    displaying status panels 320  
    gateways 37  
    target systems 320  
    values for target systems 322  
status messages 318  
status of automation control file 14  
STOP command 290  
stopping  
    processor operations 307  
    target processors 290  
structure  
    conditions 76, 91  
    deallocation 80, 89  
    duplexing  
        system-managed 90  
        user-managed 90  
    pending policy changes 91, 138  
    rebuild 80, 90  
        system-managed 80, 90  
        user-managed 80, 90  
subsystem 5  
switch  
    chained 334  
    disabling 344  
    FICON 211  
    FICON cascaded 211  
    logical switch number (LSN) 333, 334  
    port 342  
    removing 344  
    restoring 342  
    switch identifier 334  
switch chain 216  
switch data  
    DISPLAY SWITCH 234  
switch device number 334  
switch log  
    LOGREC command 238  
SYNC SWITCH command 252

syntax diagrams  
    format 5  
sysplex  
    sysplex timer 56  
sysplex timer  
    displaying information 56  
SYSRESET command 291  
system operations commands  
    ACF 14  
    AOCHHELP 16  
    AOCTRACE 17  
    DISPACF 19  
    DISPAOPS 20  
    DISPASF 22  
    DISPASST 24  
    DISPAUTO 26  
    DISPERRS 29  
    DISPEVT 31  
    DISPEVTS 33  
    DISPFLGS 35  
    DISPGW 37  
    DISPINFO 42  
    DISPMSGs 44  
    DISPNTFY 46  
    DISPSCHD 47  
    DISPSTAT 51  
    DISPSYS 56  
    DISPTREE 58  
    DISPTRG 59  
    DISPWTOR 61  
    DRAINJES 62  
    EXPLAIN 63  
    general info 9  
    GWTRACE 64  
    INGAMS 65  
    INGAUTO 71  
    INGCICS 92  
    INGEVENT 95  
    INGFILT 97  
    INGGROUP 100  
    INGHIST 110  
    INGIMS 112  
    INGINFO 115  
    INGLIST 117  
    INGLKUP 121  
    INGNTFY 123  
    INGOPC 125  
    INGRELS 154  
    INGREQ 156  
    INGRPT 163  
    INGSCHED 165  
    INGSEND using gateway  
        sessions 175  
    INGSEND using RMTCMD 172  
    INGSET 178  
    INGTHRES 181  
    INGTOPO 187  
    INGTRIG 188  
    INGVOTE 190  
    INGVTAM 193  
    JES2 194  
    MONITOR 195  
    RESTART 196  
    RESYNC 197  
    SETASST 198  
    SETHOLD 201  
    SETSTATE 202

system operations commands (*continued*)  
    SETTIMER 205  
system parameters 56  
system-managed duplexing 90  
system-managed rebuild 80, 90

## T

target console lock  
    removing with ISQOVRD 303  
target control task  
    ISQEXEC 300  
TARGET parameter 10  
target processor  
    starting 289  
target processors  
    resetting 291  
    stopping 290  
target system  
    displaying and changing  
        information 328  
target system processor  
    restarting 288  
thresholds  
    setting 181  
time-out value  
    changing 248  
tokens  
    logical 342  
    physical 343  
trace  
    with AOCTRACE command 17

## U

UCB (unit control block) 374  
UNBLOCK command 253  
UNCHAIN command 254  
UNLOCK command 256  
updating I/O operations information  
    about an ESCON Director 248  
user-managed duplexing 90  
user-managed rebuild 80, 90

## V

vary path request  
    chained path 349  
    display failed varies 236  
    port attributes 349  
Vary Path requests  
    viewing failed requests 236  
varying paths 349  
View command (NetView) 329  
VTAM  
    name 350

## W

warm startup 14  
wildcards 4  
WRITE command 257  
WTORES  
    displaying outstanding WTORES 61



---

# Readers' Comments — We'd Like to Hear from You

System Automation for OS/390  
Operator's Commands  
Version 2 Release 2

Publication No. SC33-7042-05

Overall, how satisfied are you with the information in this book?

	Very Satisfied	Satisfied	Neutral	Dissatisfied	Very Dissatisfied
Overall satisfaction	<input type="checkbox"/>	<input type="checkbox"/>	<input type="checkbox"/>	<input type="checkbox"/>	<input type="checkbox"/>

How satisfied are you that the information in this book is:

	Very Satisfied	Satisfied	Neutral	Dissatisfied	Very Dissatisfied
Accurate	<input type="checkbox"/>	<input type="checkbox"/>	<input type="checkbox"/>	<input type="checkbox"/>	<input type="checkbox"/>
Complete	<input type="checkbox"/>	<input type="checkbox"/>	<input type="checkbox"/>	<input type="checkbox"/>	<input type="checkbox"/>
Easy to find	<input type="checkbox"/>	<input type="checkbox"/>	<input type="checkbox"/>	<input type="checkbox"/>	<input type="checkbox"/>
Easy to understand	<input type="checkbox"/>	<input type="checkbox"/>	<input type="checkbox"/>	<input type="checkbox"/>	<input type="checkbox"/>
Well organized	<input type="checkbox"/>	<input type="checkbox"/>	<input type="checkbox"/>	<input type="checkbox"/>	<input type="checkbox"/>
Applicable to your tasks	<input type="checkbox"/>	<input type="checkbox"/>	<input type="checkbox"/>	<input type="checkbox"/>	<input type="checkbox"/>

Please tell us how we can improve this book:

Thank you for your responses. May we contact you?  Yes  No

When you send comments to IBM, you grant IBM a nonexclusive right to use or distribute your comments in any way it believes appropriate without incurring any obligation to you.

\_\_\_\_\_  
Name

\_\_\_\_\_  
Address

\_\_\_\_\_  
Company or Organization

\_\_\_\_\_  
Phone No.



Fold and Tape

Please do not staple

Fold and Tape



NO POSTAGE  
NECESSARY  
IF MAILED IN THE  
UNITED STATES

# BUSINESS REPLY MAIL

FIRST-CLASS MAIL PERMIT NO. 40 ARMONK, NEW YORK

POSTAGE WILL BE PAID BY ADDRESSEE

IBM Deutschland Entwicklung GmbH  
Department 3248  
Schoenaicher Strasse 220  
D-71032 Boeblingen  
Federal Republic of Germany

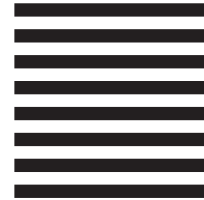

Fold and Tape

Please do not staple

Fold and Tape





Program Number: 5645-006

Printed in U.S.A.

SC33-7042-05



Spine information:



**System Automation for OS/390 V2R2.0  
Operator's Commands**

Version 2 Release 2

SC33-7042-05